

Owner's Manual



LAWN TRACTOR

18.0 HP, 42" Mower

Electric Start

Automatic Transmission

Model No.

917.273160

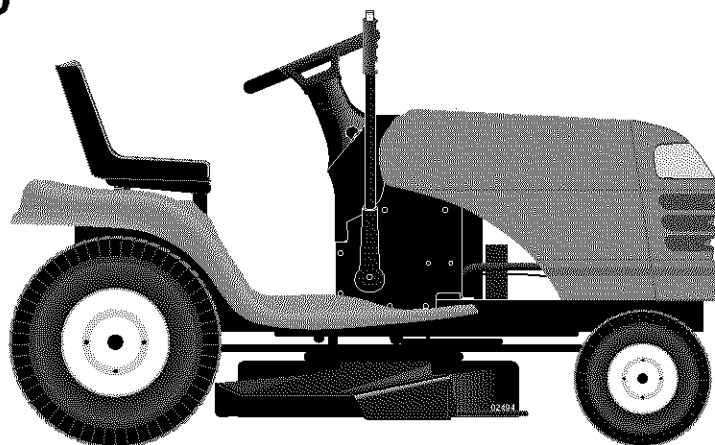

This product has a low emission engine which operates differently from previously built engines. Before you start the engine, read and understand this Owner's Manual.

IMPORTANT:

Read and follow all Safety Rules and Instructions before operating this equipment.

For answers to your questions about this product, Call:

1-800-659-5917

Sears Craftsman Help Line
5 am - 5 pm, Mon - Sat

Sears, Roebuck and Co., Hoffman Estates, IL 60179 U.S.A

Visit our Craftsman website: www.sears.com/craftsman

TABLE OF CONTENTS

Warranty	2	Maintenance Schedule	18
Safety Rules	3	Service and Adjustments.....	22
Product Specifications	6	Storage	28
AssemblyPre-Operation	8	Troubleshooting	29
Operation.....	11	Repair Parts.....	34
Maintenance	18	Sears Service	Back Cover

WARRANTY

LIMITED WARRANTY ON CRAFTSMAN RIDING EQUIPMENT

For two (2) years from the date of purchase, if this Craftsman Riding Equipment is maintained, lubricated and tuned up according to the instructions in the owner's manual, Sears will repair or replace free of charge any parts that are found to be defective in material or workmanship according to the guidelines of coverage listed below. Sears will also provide free labor for these applicable warranted parts for the two full years. During the first 30 days of purchase, there will be no charges to service the product at your home for issues covered by this warranty. (See exclusions below). For your convenience, IN HOME warranty service will still be available after the first 30 days of purchase, but a trip charge will apply. This charge will be waived if the Craftsman product is dropped off at an authorized Sears location. For the nearest authorized Sears location, please call 1-800-4-MY-HOME®. This warranty applies only while this product is within the United States.

This Warranty does not cover:

- Expendable items which become worn during normal use, including but not limited to blades, spark plugs, air cleaners, belts, and oil filters.
- Standard Maintenance Servicing, oil changes, or tune-ups
- Tire replacement or repair caused by punctures from outside objects, such as nails, thorns, stumps, or glass.
- Repairs necessary because of operator abuse, including but not limited to, damage caused by towing objects beyond the capability of the riding equipment, impacting objects that bend the frame or crankshaft, or over-speeding the engine.
- Repairs necessary because of operator negligence, including but not limited to, electrical and mechanical damage caused by improper storage, failure to use the proper grade and amount of engine oil, failure to keep the deck clear of flammable debris, or failure to maintain the equipment according to the instructions contained in the owner's manual.
- Engine (fuel system) cleaning or repairs caused by fuel determined to be contaminated or oxidized (stale). In general, fuel should be used within 30 days of its purchase date.
- Normal deterioration and wear of the exterior finishes, or product label replacement.
- Riding equipment used for commercial or rental purposes.

LIMITED WARRANTY ON BATTERY

For ninety (90) days from date of purchase, if any battery included with this riding equipment proves defective in material or workmanship and our testing determines the battery will not hold a charge, Sears will replace the battery at no charge. During the first 30 days of purchase, there will be no charges to replace the battery at your HOME. After the first 30 days, for your convenience, IN-HOME warranty service will still be available but a trip charge will apply. This charge will be waived if the Craftsman product is dropped off at an authorized Sears location. For the nearest authorized Sears location, please call 1-800-4-MY-HOME®.

This battery warranty applies only while this product is within the United States.

This warranty gives you specific legal rights, and you may also have other rights, which vary, from state to state.

Sears, Roebuck and Co., Dept. 817WA, Hoffman Estates, IL 60179

SAFETY RULES

IMPORTANT: This cutting machine is capable of amputating hands and feet and throwing objects. Failure to observe the following safety instructions could result in serious injury or death.

 **WARNING:** In order to prevent accidental starting when setting up, transporting, adjusting or making repairs, always disconnect spark plug wire and place wire where it cannot contact spark plug.

 **WARNING:** Do not coast down a hill in neutral, you may lose control of the tractor.

 **WARNING:** Tow only the attachments that are recommended by and comply with specifications of the manufacturer of your tractor. Use common sense when towing. Operate only at the lowest possible speed when on a slope. Too heavy of a load, while on a slope, is dangerous. Tires can lose traction with the ground and cause you to lose control of your tractor.

 **WARNING:** Engine exhaust, some of its constituents, and certain vehicle components contain or emit chemicals known to the State of California to cause cancer and birth defects or other reproductive harm.

 **WARNING:** Battery posts, terminals and related accessories contain lead and lead compounds, chemicals known to the State of California to cause cancer and birth defects or other reproductive harm. **Wash hands after handling.**

I. GENERAL OPERATION

- Read, understand, and follow all instructions in the manual and on the machine before starting.
- Only allow responsible adults, who are familiar with the instructions, to operate the machine.
- Clear the area of objects such as rocks, toys, wire, etc., which could be picked up and thrown by the blade.
- Be sure the area is clear of other people before mowing. Stop machine if anyone enters the area.
- Never carry passengers.

- Do not mow in reverse unless absolutely necessary. Always look down and behind before and while backing.
- Be aware of the mower discharge direction and do not point it at anyone. Do not operate the mower without either the entire grass catcher or the guard in place.
- Slow down before turning.
- Never leave a running machine unattended. Always turn off blades, set parking brake, stop engine, and remove keys before dismounting.
- Turn off blades when not mowing.
- Stop engine before removing grass catcher or unclogging chute.
- Mow only in daylight or good artificial light.
- Do not operate the machine while under the influence of alcohol or drugs.
- Watch for traffic when operating near or crossing roadways.
- Use extra care when loading or unloading the machine into a trailer or truck.
- Data indicates that operators, age 60 years and above, are involved in a large percentage of riding mower-related injuries. These operators should evaluate their ability to operate the riding mower safely enough to protect themselves and others from serious injury.
- Keep machine free of grass, leaves or other debris build-up which can touch hot exhaust / engine parts and burn. Do not allow the mower deck to plow leaves or other debris which can cause build-up to occur. Clean any oil or fuel spillage before operating or storing the machine. Allow machine to cool before storage.

II. SLOPE OPERATION

Slopes are a major factor related to loss-of-control and tipover accidents, which can result in severe injury or death. All slopes require extra caution. If you cannot back up the slope or if you feel uneasy on it, do not mow it.

SAFETY RULES

DO:

- Mow up and down slopes, not across.
- Remove obstacles such as rocks, tree limbs, etc.
- Watch for holes, ruts, or bumps. Uneven terrain could overturn the machine. *Tall grass can hide obstacles.*
- Use slow speed. Choose a low gear so that you will not have to stop or shift while on the slope.
- Follow the manufacturer's recommendations for wheel weights or counterweights to improve stability.
- Use extra care with grass catchers or other attachments. These can change the stability of the machine.
- Keep all movement on the slopes *slow* and *gradual*. Do not make sudden changes in speed or direction.
- Avoid starting or stopping on a slope. If tires lose traction, disengage the blades and proceed slowly *straight* down the slope.

DO NOT:

- *Do not* turn on slopes unless necessary, and then, turn slowly and gradually downhill, if possible.
- *Do not* mow near drop-offs, ditches, or embankments. The mower could suddenly turn over if a wheel is over the edge of a cliff or ditch, or if an edge caves in.
- *Do not* mow on wet grass. Reduced traction could cause sliding.
- *Do not* try to stabilize the machine by putting your foot on the ground.
- *Do not* use grass catcher on steep slopes.

III. CHILDREN

Tragic accidents can occur if the operator is not alert to the presence of children. Children are often attracted to the machine and the mowing activity. *Never* assume that children will remain where you last saw them.

- Keep children out of the mowing area and under the watchful care of another responsible adult.
- Be alert and turn machine off if children enter the area.
- Before and when backing, look behind and *down* for small children.

- Never carry children. They may fall off and be seriously injured or interfere with safe machine operation.
- Never allow children to operate the machine.
- Use extra care when approaching blind corners, shrubs, trees, or other objects that may obscure vision.

IV. SERVICE

- Use extra care in handling gasoline and other fuels. They are flammable and vapors are explosive.
 - Use only an approved container.
 - Never remove gas cap or add fuel with the engine running. Allow engine to cool before refueling. Do not smoke.
 - Never refuel the machine indoors.
 - Never store the machine or fuel container inside where there is an open flame, such as a water heater.
- Never run a machine inside a closed area.
- Keep nuts and bolts, especially blade attachment bolts, tight and keep equipment in good condition.
- Never tamper with safety devices. Check their proper operation regularly.
- Keep machine free of grass, leaves, or other debris build-up. Clean oil or fuel spillage. Allow machine to cool before storing.
- Stop and inspect the equipment if you strike an object. Repair, if necessary, before restarting.
- Never make adjustments or repairs with the engine running.
- Grass catcher components are subject to wear, damage, and deterioration, which could expose moving parts or allow objects to be thrown. Frequently check components and replace with manufacturer's recommended parts, when necessary.
- Mower blades are sharp and can cut. Wrap the blade(s) or wear gloves, and use extra caution when servicing them.
- Check brake operation frequently. Adjust and service as required.

SAFETY RULES

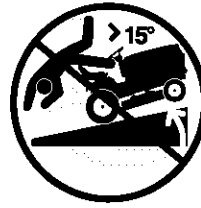

- Be sure the area is clear of other people before mowing. Stop machine if anyone enters the area.
- Never carry passengers or children even with the blades off.
- Do not mow in reverse unless absolutely necessary. Always look down and behind before and while backing.
- Never carry children. They may fall off and be seriously injured or interfere with safe machine operation.
- Keep children out of the mowing area and under the watchful care of another responsible adult.
- Be alert and turn machine off if children enter the area.
- Before and when backing, look behind and down for small children.
- Mow up and down slopes (15° Max), not across.
- Remove obstacles such as rocks, tree limbs, etc.
- Watch for holes, ruts, or bumps. Uneven terrain could overturn the machine. Tall grass can hide obstacles.
- Use slow speed. Choose a low gear so that you will not have to stop or shift while on the slope.
- Avoid starting or stopping on a slope. If tires lose traction, disengage the blades and proceed slowly straight down the slope.
- If machine stops while going uphill, disengage blades, shift into reverse and back down slowly.
- Do not turn on slopes unless necessary, and then, turn slowly and gradually downhill, if possible.

PRODUCT SPECIFICATIONS

Gasoline Capacity and Type:	1.25 Gallons Unleaded Regular
Oil Type (API-SF-SJ):	SAE10W30(Above 32°F) SAE 5W-30(Below 32°F)
Oil Capacity:	W/Filter 4.0 Pints W/O Filter 3.5 Pints
Spark Plug: (GAP: .040")	Champion RC12YC
Ground Speed (MPH):	Forward: 5.5 Reverse: 2.4
Tire Pressure:	Front: 14 PSI Rear: 10 PSI
Charging System:	15 Amps @ 3600RPM
Battery:	Amp/Hr: 28 Min. CCA: 230 Case Size: U1R
Blade Bolt Torque:	27–35 Ft. Lbs.

CONGRATULATIONS on your purchase of a new tractor. It has been designed, engineered and manufactured to give you the best possible dependability and performance.

Should you experience any problem you cannot easily remedy, please contact a Sears or other qualified service center. We have competent, well-trained technicians and the proper tools to service or repair this tractor.

Please read and retain this manual. The instructions will enable you to assemble and maintain your tractor properly. Always observe the "SAFETY RULES".

CUSTOMER RESPONSIBILITIES

- Read and observe the safety rules.
- Follow a regular schedule in maintaining, caring for and using your tractor.
- Follow the instructions under "Maintenance" and "Storage" sections of this owner's manual.

⚠WARNING: This tractor is equipped with an internal combustion engine and should not be used on or near any unimproved forest-covered, brush-covered or grass-covered land unless the engine's exhaust system is equipped with a spark arrester meeting applicable local or state laws (if any). If a spark arrester is used, it should be maintained in effective working order by the operator.

In the state of California the above is required by law (Section 4442 of the California Public Resources Code). Other states may have similar laws. Federal laws apply on federal lands. A spark arrester for the muffler is available through your nearest Sears service center (See REPAIR PARTS section of this manual).

REPAIR PROTECTION AGREEMENTS

Congratulations on making a smart purchase. Your new Craftsman® product is designed and manufactured for years of dependable operation. But like all products, it may require repair from time to time. That's when having a Repair Protection Agreement can save you money and aggravation.

Purchase a Repair Protection Agreement now and protect yourself from unexpected hassle and expense.

Here's what's included in the Agreement:

- **Expert service** by our 12,000 professional repair specialists.
- **Unlimited service and no charge** for parts and labor on all covered repairs.
- **Product replacement** if your covered product can't be fixed.
- **Discount of 10%** from regular price of service and service-related parts not covered by the agreement; also, 10% off regular price of preventive maintenance check.
- **Fast help by phone** – phone support from a Sears technician on products requiring in-home repair, plus convenient repair scheduling.

Once you purchase the Agreement, a simple phone call is all that it takes for you to schedule service. You can call anytime day or night, or schedule a service appointment online.

Sears has over 12,000 professional repair specialists, who have access to over 4.5 million quality parts and accessories. That's the kind of professionalism you can count on to help prolong the life of your new purchase for years to come. Purchase your Repair Protection Agreement today! **Some limitations and exclusions apply. For prices and additional information call 1-800-827-6655.**

SEARS INSTALLATION SERVICE

For Sears professional installation of home appliances, garage door openers, water heaters, and other major home items, in the U.S.A. call 1-800-4-MY-HOME®

UNASSEMBLED PARTS

Steering Wheel

Steering Wheel Insert

(1) Locknut 1/2-20

(1) Locknut 1/4-28

(1) Large Flat Washer

(1) Hex Bolt 1/4-28 x 1-1/4

Steering Boot

Steering Wheel Adapter

Steering Extension Shaft

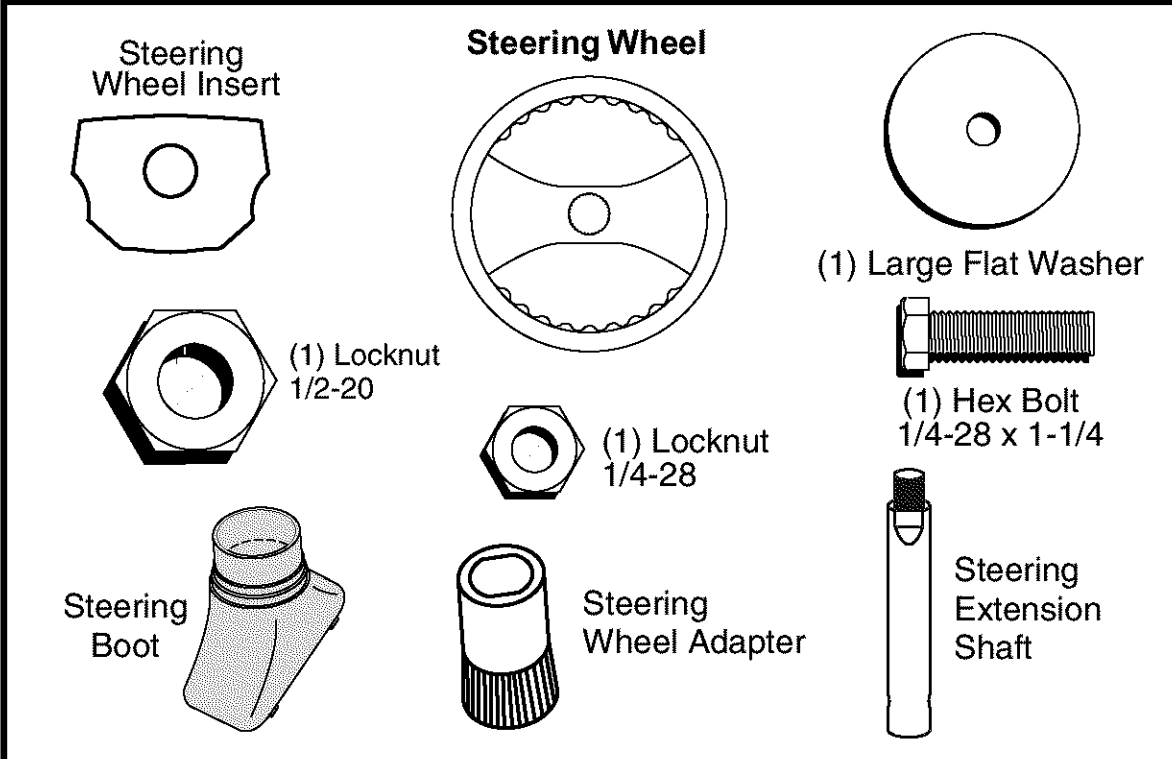

Seat

(1) Washer 17/32 x 1-3/16 x 12 Gauge

(1) Knob

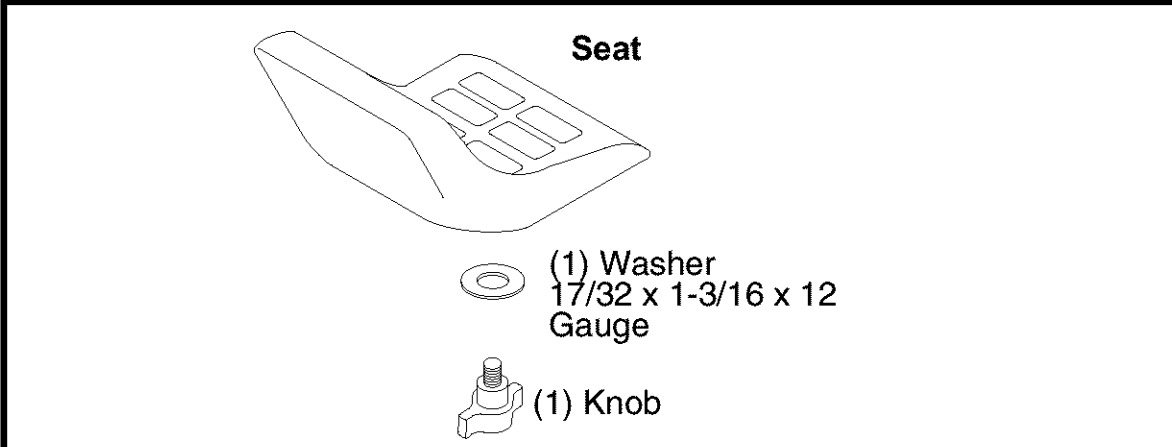

(1) Oil Drain Tube For Future Use

Slope Sheet

Keys

Video Cassette

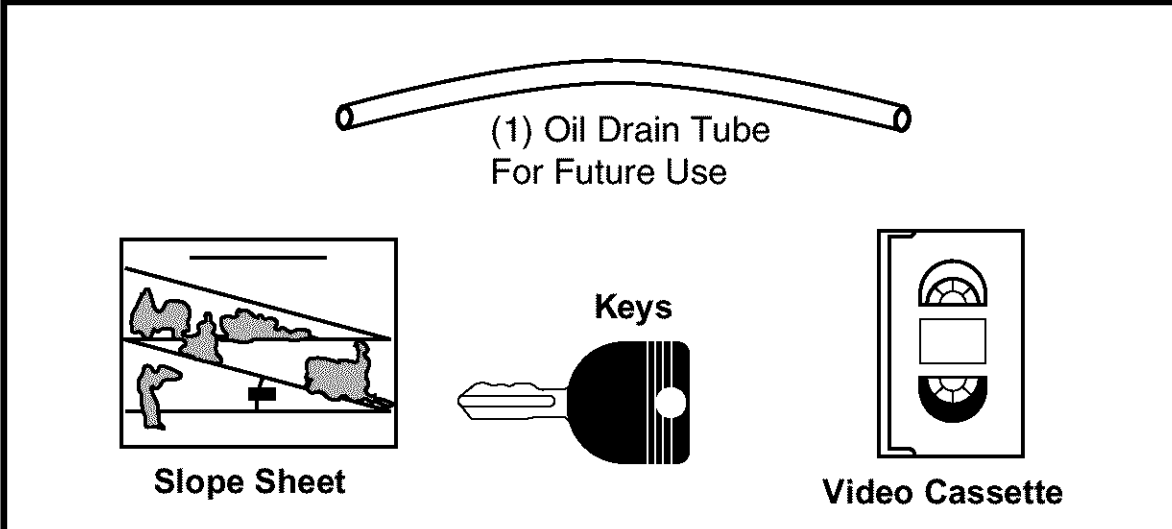

ASSEMBLY/PRE-OPERATION

Your new tractor has been assembled at the factory with the exception of those parts left unassembled for shipping purposes. To ensure safe and proper operation of your tractor all parts and hardware you assemble must be tightened securely. Use the correct tools as necessary to insure proper tightness. Review the video cassette before you begin.

TOOLS REQUIRED FOR ASSEMBLY

A socket wrench set will make assembly easier. Standard wrench sizes are listed.

(1) 3/4" wrench	Pliers
(2) 7/16" wrenches	Utility knife

Tire pressure gauge

When right or left hand is mentioned in this manual, it means when you are in the operating position (seated behind the steering wheel).

TO REMOVE TRACTOR FROM CARTON

UNPACK CARTON

1. Remove all accessible loose parts and parts boxes from carton.
2. Cut along dotted lines on all four panels of carton. Remove end panels and lay side panels flat.
3. Check for any additional loose parts or cartons and remove.

BEFORE REMOVING TRACTOR FROM SKID

ATTACH STEERING WHEEL

ASSEMBLE EXTENSION SHAFT AND BOOT

1. Slide extension shaft onto lower steering shaft. Align mounting holes in extension and lower shafts and install 1/4 hex bolt and locknut. Tighten securely.
- IMPORTANT:** Tighten bolt and nut securely to 10-12 ft. lbs torque.
2. Place tabs of steering boot over tab slots in dash and push down to secure.

INSTALL STEERING WHEEL

3. Position front wheels of the tractor so they are pointing straight forward.
4. Remove steering wheel adapter from steering wheel and slide adapter onto steering shaft extension.
5. Position steering wheel so cross bars are horizontal (left to right) and slide inside boot and onto adapter.
6. Assemble large flat washer, 1/2 hex nut and tighten securely.

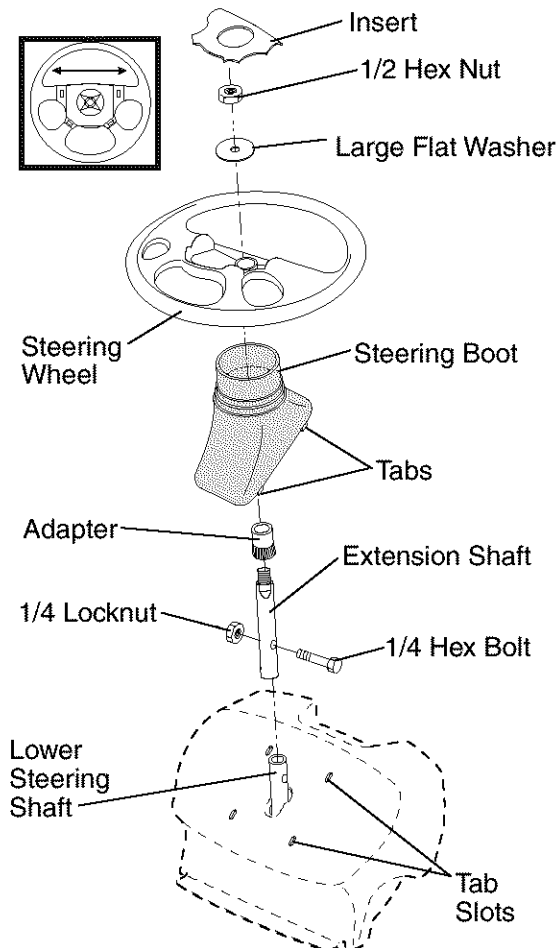

7. Snap steering wheel insert into center of steering wheel.
8. Remove protective materials from tractor hood and grill.

IMPORTANT: Check for and remove any staples in skid that may puncture tires where tractor is to roll off skid.

HOW TO SET UP YOUR TRACTOR

INSTALL SEAT

Adjust seat before tightening adjustment knob.

1. Remove adjustment knob and flat washer securing seat to cardboard packing and set aside for assembly of seat to tractor.
2. Pivot seat upward and remove from the cardboard packing. Remove the cardboard packing and discard.

3. Place seat on seat pan so head of shoulder bolts are positioned over the large slotted holes in pan.
4. Push down on seat to engage shoulder bolts in slots and pull seat towards rear of tractor.
5. Pivot seat and pan forward and assemble adjustment knob and flat washer loosely. Do not tighten.
6. Lower seat into operating position and sit in seat.
7. Slide seat until a comfortable position is reached which allows you to press clutch/brake pedal all the way down.
8. Get off seat without moving its adjusted position.
9. Raise seat and tighten adjustment knob securely.

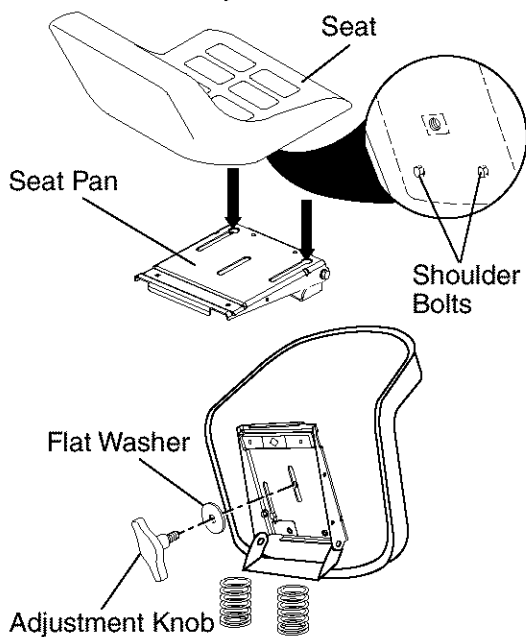

CHECK BATTERY

1. Lift seat pan to raised position.
- NOTE:** If this battery is put into service after month and year indicated on label (label located between terminals) charge battery for minimum of one hour at 6-10 amps. (See "BATTERY" in Maintenance section of this manual for charging instructions).

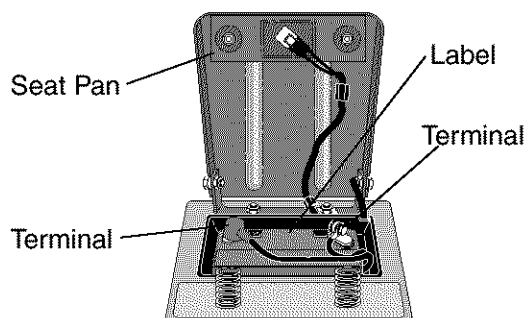

NOTE: You may now roll or drive your tractor off the skid. Follow the appropriate instruction below to remove the tractor from the skid.

TO ROLL TRACTOR OFF SKID (See Operation section for location and function of controls)

1. Press lift lever plunger and raise attachment lift lever to its highest position.
2. Release parking brake by depressing clutch/brake pedal.
3. Place freewheel control in "transmission disengaged" position (See "TO TRANSPORT" in the Operation section of this manual).
4. Roll tractor forward off skid.
5. Remove banding holding deflector shield up against tractor.

TO DRIVE TRACTOR OFF SKID (See Operation section for location and function of controls)

WARNING: Before starting, read, understand and follow all instructions in the Operation section of this manual. Be sure tractor is in a well-ventilated area. Be sure the area in front of tractor is clear of other people and objects.

1. Be sure all the above assembly steps have been completed.
2. Check engine oil level and fill fuel tank with gasoline.
3. Place freewheel control in "transmission engaged" position. (See "TO TRANSPORT" in the Operation section of this manual).
4. Sit on seat in operating position, depress clutch/brake pedal and set the parking brake.
5. Place motion control lever in neutral (N) position.
6. Press lift lever plunger and raise attachment lift lever to its highest position.
7. Start the engine. After engine has started, move throttle control to idle position.
8. Release parking brake.
9. Slowly move the motion control lever forward and slowly drive tractor off skid.
10. Apply brake to stop tractor, set parking brake and place motion control lever in neutral position.
11. Turn ignition key to "STOP" position. Continue with the instructions that follow.

INSTALL MULCHER PLATE

(If previously removed)

1. Raise and hold deflector shield in upright position.
2. Place front of mulcher plate over front of mower deck opening and slide into place, as shown.
3. Hook front latch into hole on front of mower deck.
4. Hook rear latch into hole on back of mower deck.

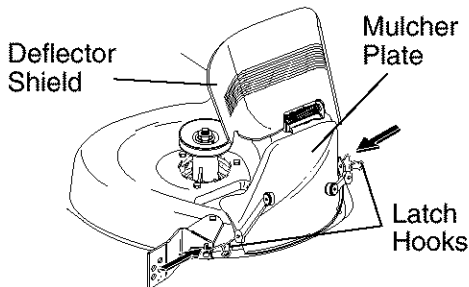

CAUTION: Do not remove deflector shield from mower.

TO CONVERT TO BAGGING OR DISCHARGING

Simply remove mulcher plate and store in a safe place. Your mower is now ready for discharging or installation of optional grass catcher accessory.

NOTE: It is not necessary to change blades. The mulching blades are designed for discharging and bagging also.

CHECK TIRE PRESSURE

The tires on your tractor were overinflated at the factory for shipping purposes. Correct tire pressure is important for best cutting performance.

- Reduce tire pressure to PSI shown in "PRODUCT SPECIFICATIONS" section of this manual.

CHECK DECK LEVELNESS

For best cutting results, mower housing should be properly leveled. See "TO LEVEL MOWER HOUSING" in the Service and Adjustments section of this manual.

CHECK FOR PROPER POSITION OF ALL BELTS

See the figures that are shown for replacing motion and mower blade drive belts in the Service and Adjustments section of this manual. Verify that the belts are routed correctly.

CHECK BRAKE SYSTEM

After you learn how to operate your tractor, check to see that the brake is properly adjusted. See "TO ADJUST BRAKE" in the Service and Adjustments section of this manual.

✓ CHECKLIST

Before you operate your new tractor, we wish to assure that you receive the best performance and satisfaction from this quality product.

Please review the following checklist:

- ✓ All assembly instructions have been completed.
 - ✓ No remaining loose parts in carton.
 - ✓ Battery is properly prepared and charged. (Minimum 1 hour at 6 amps).
 - ✓ Seat is adjusted comfortably and tightened securely.
 - ✓ All tires are properly inflated. (For shipping purposes, the tires were overinflated at the factory).
 - ✓ Be sure mower deck is properly leveled side-to-side/front-to-rear for best cutting results. (Tires must be properly inflated for leveling).
 - ✓ Check mower and drive belts. Be sure they are routed properly around pulleys and inside all belt keepers.
 - ✓ Check wiring. See that all connections are still secure and wires are properly clamped.
 - ✓ Before driving tractor, be sure freewheel control is in "transmission engaged" position (see "TO TRANSPORT" in the Operation section of this manual).
- While learning how to use your tractor, pay extra attention to the following important items:
- ✓ Engine oil is at proper level.
 - ✓ Fuel tank is filled with fresh, clean, regular unleaded gasoline.
 - ✓ Become familiar with all controls - their location and function. Operate them before you start the engine.
 - ✓ Be sure brake system is in safe operating condition.
 - ✓ It is important to purge the transmission before operating your tractor for the first time. Follow proper starting and transmission purging instructions (See "TO START ENGINE" and "PURGE TRANSMISSION" in the Operation section of this manual).

OPERATION

These symbols may appear on your tractor or in literature supplied with the product. Learn and understand their meaning.

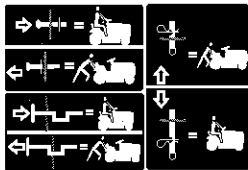
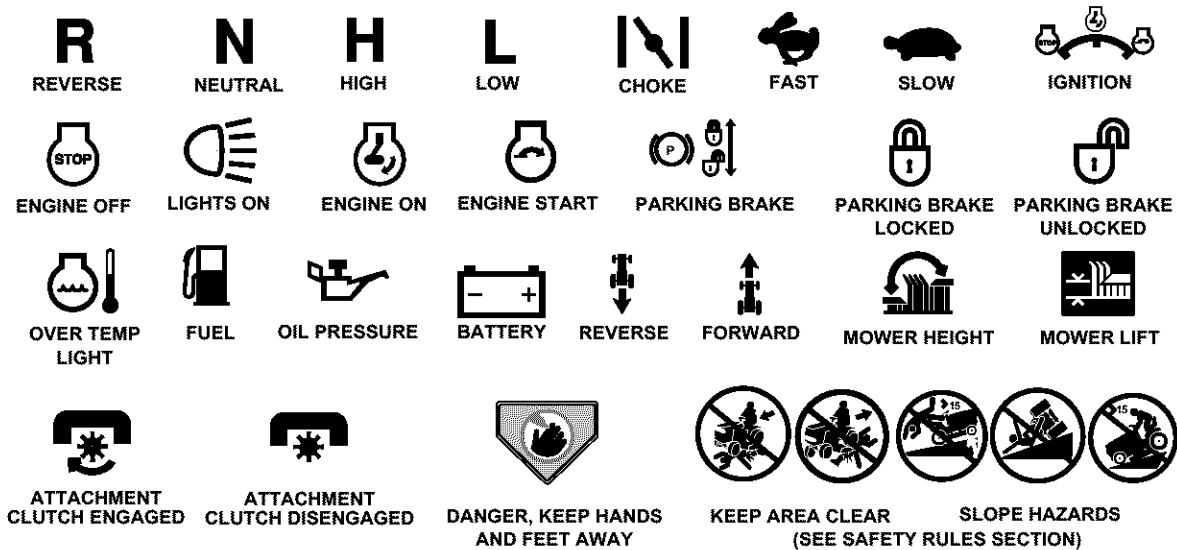

FREE WHEEL
(Automatic Models only)



Failure to follow instructions could result in serious injury or death. The safety alert symbol is used to identify safety information about hazards which can result in death, serious injury and/or property damage.



DANGER indicates a hazard which, if not avoided, will result in death or serious injury.



WARNING indicates a hazard which, if not avoided, could result in death or serious injury.



CAUTION indicates a hazard which, if not avoided, might result in minor or moderate injury.

CAUTION when used **without** the alert symbol, indicates a situation that could result in damage to the tractor and/or engine.



HOT SURFACES indicates a hazard which, if not avoided, could result in death, serious injury and/or property damage.



FIRE indicates a hazard which, if not avoided, could result in death, serious injury and/or property damage.

KNOW YOUR TRACTOR

READ THIS OWNER'S MANUAL AND SAFETY RULES BEFORE OPERATING YOUR TRACTOR

Compare the illustrations with your tractor to familiarize yourself with the locations of various controls and adjustments. Save this manual for future reference.

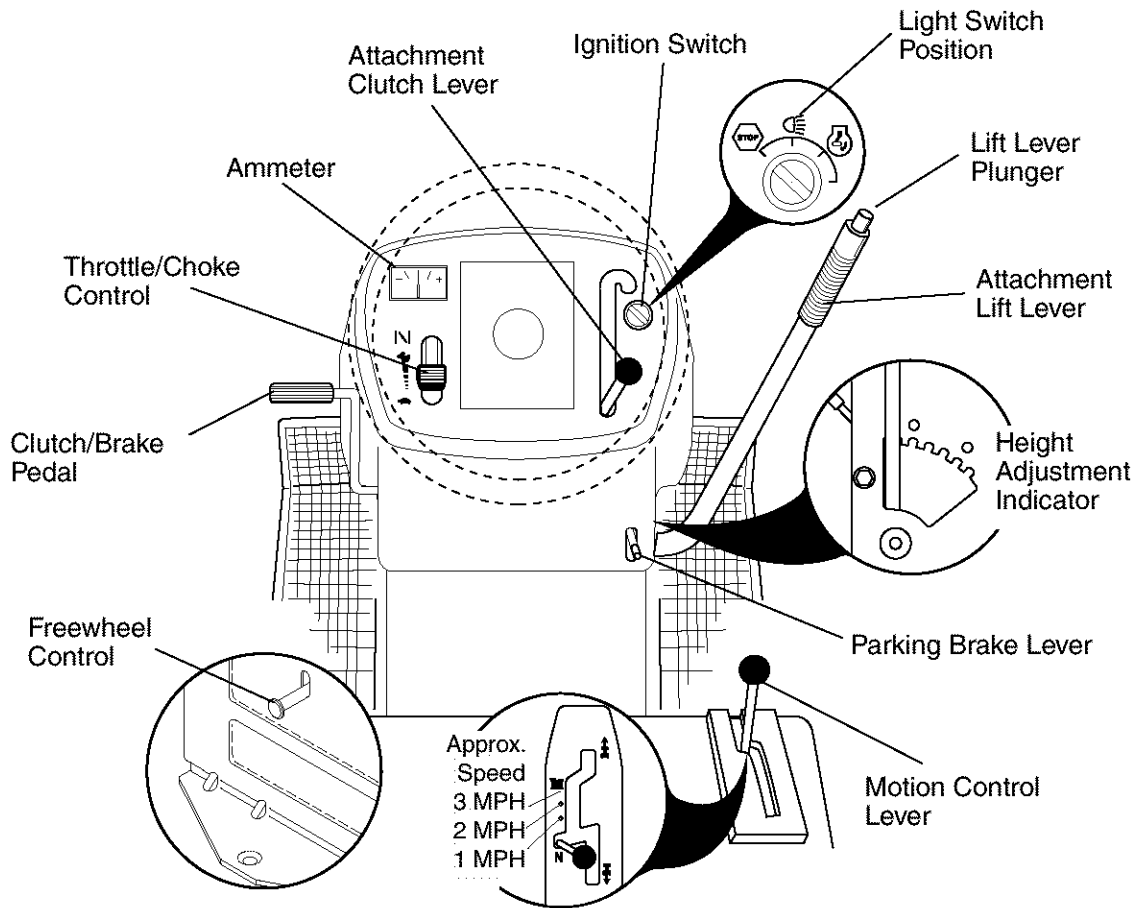

Our tractors conform to the safety standards of the American National Standards Institute.

AMMETER - Indicates charging (+) or discharging (-) of battery.

ATTACHMENT CLUTCH LEVER - Used to engage the mower blades, or other attachments mounted to your tractor.

ATTACHMENT LIFT LEVER - Used to raise, lower, and adjust the mower deck or other attachments mounted to your tractor.

CLUTCH/BRAKE PEDAL - Used for declutching and braking the tractor and starting the engine.

MOTION CONTROL LEVER - Selects the speed and direction of tractor.

IGNITION SWITCH - Used for starting and stopping the engine.

LIFT LEVER PLUNGER - Used to release attachment lift lever when changing its position.

LIGHT SWITCH POSITION - Turns the headlights on and off.

PARKING BRAKE LEVER - Locks clutch/brake pedal into the brake position.

THROTTLE/CHOKE CONTROL - Used for starting and controlling engine speed.

FREEWHEEL CONTROL - Disengages transmission for pushing or slowly towing the tractor with the engine off.



The operation of any tractor can result in foreign objects thrown into the eyes, which can result in severe eye damage. Always wear safety glasses or eye shields while operating your tractor or performing any adjustments or repairs. We recommend standard safety glasses or a wide vision safety mask worn over spectacles.

HOW TO USE YOUR TRACTOR TO SET PARKING BRAKE

Your tractor is equipped with an operator presence sensing switch. When engine is running, any attempt by the operator to leave the seat without first setting the parking brake will shut off the engine.

1. Depress clutch/brake pedal all the way down and hold.
2. Pull parking brake lever up and release pressure from clutch/brake pedal. Pedal should remain in brake position. Make sure parking brake will hold tractor secure.

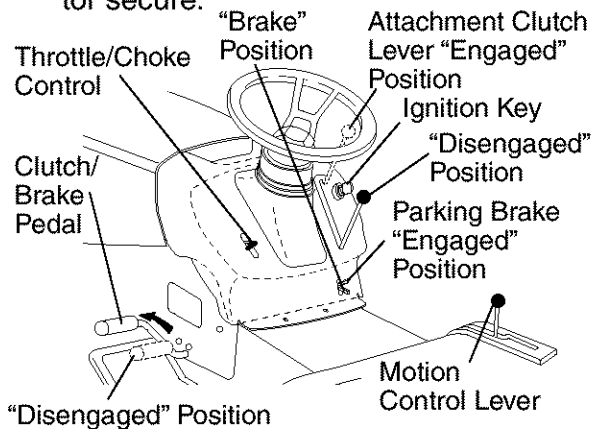

STOPPING

MOWER BLADES -

- To stop mower blades, move attachment clutch lever to disengaged position.

GROUND DRIVE -

- To stop ground drive, depress clutch/brake pedal all the way down.
- Move motion control lever to neutral (N) position.

IMPORTANT: The motion control lever does not return to neutral (N) position when the clutch/brake pedal is depressed.

ENGINE -

- Move throttle control between half and full speed (fast) position.

NOTE: Failure to move throttle control between half and full speed (fast) position, before stopping, may cause engine to "backfire".

- Turn ignition key to "STOP" position and remove key. Always remove key when leaving tractor to prevent unauthorized use.
- Never use choke to stop engine.

IMPORTANT: Leaving the ignition switch in any position other than "STOP" will cause the battery to discharge and go dead.

NOTE: Under certain conditions when tractor is standing idle with the engine running, hot engine exhaust gases may cause "browning" of grass. To eliminate this possibility, always stop engine when stopping tractor on grass areas.

CAUTION: Always stop tractor completely, as described above, before leaving the operator's position.

TO USE THROTTLE CONTROL

Always operate engine at full throttle.

- Operating engine at less than full throttle reduces the battery charging rate.
- Full throttle offers the best bagging and mower performance.

TO MOVE FORWARD AND BACKWARD

The direction and speed of movement is controlled by the motion control lever.

1. Start tractor with motion control lever in neutral (N) position.
2. Release parking brake.
3. Slowly move motion control lever to desired position.

TO ADJUST MOWER CUTTING HEIGHT

The position of the attachment lift lever determines the cutting height.

- Grasp lift lever.
- Press plunger with thumb and move lever to desired position.

The cutting height range is approximately 1-1/2 to 4". The heights are measured from the ground to the blade tip with the engine not running. These heights are approximate and may vary depending upon soil conditions, height of grass and types of grass being mowed.

- The average lawn should be cut to approximately 2-1/2 inches during the cool season and to over 3 inches during hot months. For healthier and better looking lawns, mow often and after moderate growth.
- For best cutting performance, grass over 6 inches in height should be mowed twice. Make the first cut relatively high; the second to desired height.

TO ADJUST GAUGE WHEELS

Gauge wheels are properly adjusted when they are slightly off the ground when mower is at the desired cutting height in operating position. Gauge wheels then keep the deck in proper position to help prevent scalping in most terrain conditions.

NOTE: Adjust gauge wheels with tractor on a flat level surface.

1. Adjust mower to desired cutting height (See "TO ADJUST MOWER CUTTING HEIGHT" in this section of manual).
2. With mower in desired height of cut position, gauge wheels should be assembled so they are slightly off the ground. Install gauge wheel in appropriate hole with shoulder bolt, 3/8 washer, and 3/8-16 locknut and tighten securely.
3. Repeat for opposite side, installing gauge wheel in same adjustment hole.

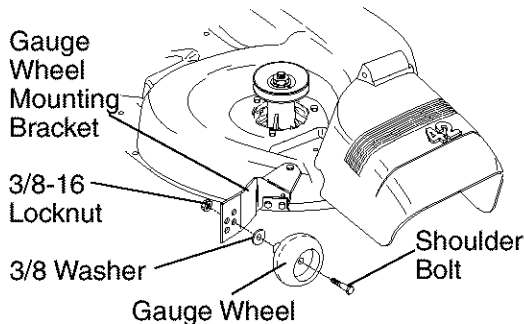

TO OPERATE MOWER

Your tractor is equipped with an operator presence sensing switch. Any attempt by the operator to leave the seat with the engine running and the attachment clutch engaged will shut off the engine.

1. Select desired height of cut.
2. Start mower blades by engaging attachment clutch control.

TO STOP MOWER BLADES -

disengage attachment clutch control.

CAUTION: Do not operate the mower without either the entire grass catcher, on mowers so equipped, or the deflector shield in place.

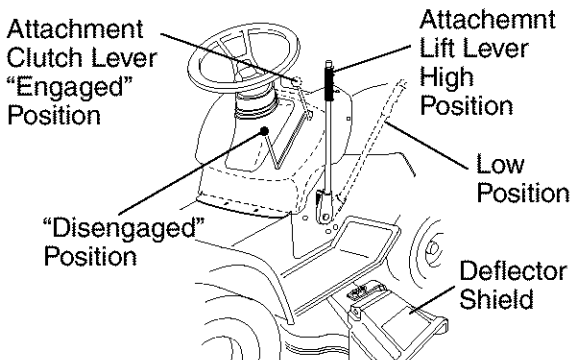

TO OPERATE ON HILLS

WARNING: Do not drive up or down hills with slopes greater than 15° and do not drive across any slope. Use the slope guide at the back of this manual.

- Choose the slowest speed before starting up or down hills.
- Avoid stopping or changing speed on hills.
- If slowing is necessary, move throttle control lever to slower position.
- If stopping is absolutely necessary, push clutch/brake pedal quickly to brake position and engage parking brake.
- Move motion control lever to neutral (N) position.

IMPORTANT: The motion control lever does not return to neutral (N) position when the clutch/brake pedal is depressed.

- To restart movement, slowly release parking brake and clutch/brake pedal.
- Slowly move motion control lever to slowest setting.
- Make all turns slowly.

TO TRANSPORT

When pushing or towing your tractor, be sure to disengage transmission by placing freewheel control in freewheeling position. Freewheel control is located at the rear drawbar of tractor.

1. Raise attachment lift to highest position with attachment lift control.
 2. Pull freewheel control out and down into the slot and release so it is held in the disengaged position.
- Do not push or tow tractor at more than two (2) MPH.
 - To re-engage transmission, reverse above procedure.

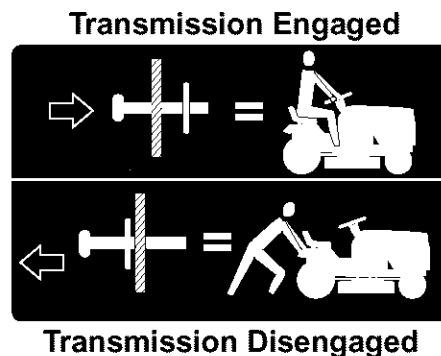

NOTE: To protect hood from damage when transporting your tractor on a truck or a trailer, be sure hood is closed and secured to tractor. Use an appropriate means of tying hood to tractor (rope, cord, etc.).

TOWING CARTS AND OTHER ATTACHMENTS

Tow only the attachments that are recommended by and comply with specifications of the manufacturer of your tractor. Use common sense when towing. Too heavy of a load, while on a slope, is dangerous. Tires can lose traction with the ground and cause you to lose control of your tractor.

BEFORE STARTING THE ENGINE CHECK ENGINE OIL LEVEL

The engine in your tractor has been shipped, from the factory, already filled with summer weight oil.

1. Check engine oil with tractor on level ground.
 2. Unthread and remove oil fill cap/dipstick; wipe oil off. Reinsert the dipstick into the tube and rest oil fill cap on the tube. Do not thread the cap onto the tube. Remove and read oil level. If necessary, add oil until "FULL" mark on dipstick is reached. Do not overfill.
- For cold weather operation you should change oil for easier starting (See the oil viscosity chart in the Maintenance section of this manual).
 - To change engine oil, see the Maintenance section in this manual.

ADD GASOLINE

- Fill fuel tank to bottom of tank filler neck. Do not overfill. Use fresh, clean, regular unleaded gasoline with a minimum of 87 octane. (Use of leaded gasoline will increase carbon and lead oxide deposits and reduce valve life). Do not mix oil with gasoline. Purchase fuel in quantities that can be used within 30 days to assure fuel freshness.

⚠ CAUTION: Wipe off any spilled oil or fuel. Do not store, spill or use gasoline near an open flame.

IMPORTANT: When operating in temperatures below 32°F(0°C), use fresh, clean winter grade gasoline to help insure good cold weather starting.

CAUTION: Alcohol blended fuels (called gasohol or using ethanol or methanol) can attract moisture which leads to separation and formation of acids during storage. Acidic gas can damage the fuel system of an engine while in storage.

To avoid engine problems, the fuel system should be emptied before storage of 30 days or longer. Drain the gas tank, start the engine and let it run until the fuel lines and carburetor are empty.

Use fresh fuel next season. See Storage Instructions for additional information. Never use engine or carburetor cleaner products in the fuel tank or permanent damage may occur.

TO START ENGINE

When starting the engine for the first time or if the engine has run out of fuel, it will take extra cranking time to move fuel from the tank to the engine.

1. Be sure freewheel control is in the transmission engaged position.
2. Sit on seat in operating position, depress clutch/brake pedal and set parking brake.
3. Place motion control lever in neutral (N) position.
4. Move attachment clutch to disengaged position.

5. Move throttle control to choke position.

NOTE: Before starting, read the warm and cold starting procedures below.

6. Insert key into ignition and turn key clockwise to start position and release key as soon as engine starts. Do not run starter continuously for more than fifteen seconds per minute. If the engine does not start after several attempts, move throttle control to fast position, wait a few minutes and try again. If engine still does not start, move the throttle control back to the choke position and retry.

WARM WEATHER STARTING (50° F and above)

7. When engine starts, move the throttle control to the fast position.
- The attachments and ground drive can now be used. If the engine does not accept the load, restart the engine and allow it to warm up for one minute using the choke as described above.

COLD WEATHER STARTING (50° F and below)

7. When engine starts, allow engine to run with the throttle control in the choke position until the engine runs roughly, then move throttle control to fast position. This may require an engine warm-up period from several seconds to several minutes, depending on the temperature.

AUTOMATIC TRANSMISSION WARM UP
Before driving the unit in cold weather, the transmission should be warmed up as follows:

1. Be sure the tractor is on level ground.
 2. Place the motion control lever in neutral. Release the parking brake and let the clutch/brake slowly return to operating position.
 3. Allow one minute for transmission to warm up. This can be done during the engine warm up period.
- The attachments can also be used during the engine warm-up period after the transmission has been warmed up.

NOTE: If at a high altitude (above 3000 feet) or in cold temperatures (below 32 F) the carburetor fuel mixture may need to be adjusted for best engine performance. (See "TO ADJUST CARBURETOR" in the Service and Adjustments section of this manual.)

PURGE TRANSMISSION

 **CAUTION:** Never engage or disengage freewheel lever while the engine is running.

To ensure proper operation and performance, it is recommended that the transmission be purged before operating tractor for the first time. This procedure will remove any trapped air inside the transmission which may have developed during shipping of your tractor.

IMPORTANT: Should your transmission require removal for service or replacement, it should be purged after reinstallation before operating the tractor.

1. Place tractor safely on level surface with engine off and parking brake set.
2. Disengage transmission by placing freewheel control in "transmission disengaged" position (See "TO TRANSPORT" in this section of manual).
3. Sitting in the tractor seat, start engine. After the engine is running, move throttle control to slow position. With motion control lever in neutral (N) position, slowly disengage clutch/brake pedal.
4. Move motion control lever to full forward position and hold for five (5) seconds. Move lever to full reverse position and hold for five (5) seconds. Repeat this procedure three (3) times.

NOTE: During this step there will be no movement of drive wheels. The air is being removed from hydraulic drive system.

5. Move motion control lever to neutral (N) position. Shutoff engine and set parking brake.
6. Engage transmission by placing freewheel control in "transmission engaged" position (See "TO TRANSPORT" in this section of manual).
7. Sitting in the tractor seat, start engine. After the engine is running, move throttle control to half (1/2) speed. With motion control lever in neutral (N) position, slowly disengage clutch/brake pedal.
8. Slowly move motion control lever forward, after the tractor moves approximately five (5) feet, slowly move motion control lever to reverse position. After the tractor moves approximately five (5) feet return the motion control lever to the neutral (N) position. Repeat this procedure with the motion control lever three (3) times.

Your transmission is now purged and ready for normal operation.

MOWING TIPS

- Mower should be properly leveled for best mowing performance. See “TO LEVEL MOWER HOUSING” in the Service and Adjustments section of this manual.
- The left hand side of mower should be used for trimming.
- Drive so that clippings are discharged onto the area that has already been cut. Have the cut area to the right of the tractor. This will result in a more even distribution of clippings and more uniform cutting.
- When mowing large areas, start by turning to the right so that clippings will discharge away from shrubs, fences, driveways, etc. After one or two rounds, mow in the opposite direction making left hand turns until finished.

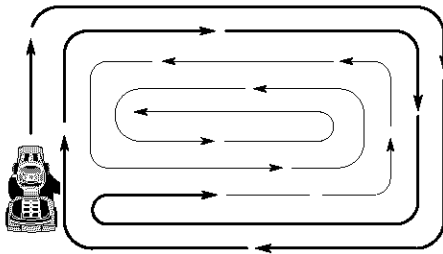

- If grass is extremely tall, it should be mowed twice to reduce load and possible fire hazard from dried clippings. Make first cut relatively high; the second to the desired height.
- Do not mow grass when it is wet. Wet grass will plug mower and leave undesirable clumps. Allow grass to dry before mowing.
- **Always operate engine at full throttle when mowing** to assure better mowing performance and proper discharge of material. Regulate ground speed by selecting a low enough gear to give the mower cutting performance as well as the quality of cut desired.
- When operating attachments, select a ground speed that will suit the terrain and give best performance of the attachment being used.

MULCHING MOWING TIPS

IMPORTANT: For best performance, keep mower housing free of built-up grass and trash. Clean after each use.

- The special mulching blade will recut the grass clippings many times and reduce them in size so that as they fall onto the lawn they will disperse into the grass and not be noticed. Also, the mulched grass will biodegrade quickly to provide nutrients for the lawn. Always mulch with your highest engine (blade) speed as this will provide the best recutting action of the blades.
- Avoid cutting your lawn when it is wet. Wet grass tends to form clumps and interferes with the mulching action. The best time to mow your lawn is the early afternoon. At this time the grass has dried, the newly cut area will not be exposed to direct sunlight.
- For best results, adjust the mower cutting height so that the mower cuts off only the top one-third of the grass blades. For extremely heavy grass, reduce your width of cut on each pass and mow slowly.

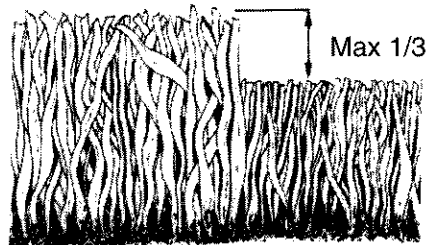

- Certain types of grass and grass conditions may require that an area be mulched a second time to completely hide the clippings. When doing a second cut, mow across (perpendicular) to the first cut path.
- Change your cutting pattern from week to week. Mow north to south one week then change to east to west the next week. This will help prevent matting and graining of the lawn.

TRACTOR

Always observe safety rules when performing any maintenance.

BRAKE OPERATION

If tractor requires more than six (6) feet stopping distance at high speed in highest gear, then brake must be adjusted. (See "TO ADJUST BRAKE" in the Service and Adjustments section of this manual).

TIRES

- Maintain proper air pressure in all tires (See "PRODUCT SPECIFICATIONS" section of this manual).
- Keep tires free of gasoline, oil, or insect control chemicals which can harm rubber.
- Avoid stumps, stones, deep ruts, sharp objects and other hazards that may cause tire damage.

NOTE: To seal tire punctures and prevent flat tires due to slow leaks, tire sealant may be purchased from your local parts dealer. Tire sealant also prevents tire dry rot and corrosion.

OPERATOR PRESENCE SYSTEM

Be sure operator presence and interlock systems are working properly. If your tractor does not function as described, repair the problem immediately.

- The engine should not start unless the brake pedal is fully depressed and attachment clutch control is in the disengaged position.
- When the engine is running, any attempt by the operator to leave the seat without first setting the parking brake should shut off the engine.
- When the engine is running and the attachment clutch is engaged, any attempt by the operator to leave the seat should shut off the engine.
- The attachment clutch should never operate unless the operator is in the seat.

BLADE CARE

For best results mower blades must be kept sharp. Replace bent or damaged blades.

BLADE REMOVAL

1. Raise mower to highest position to allow access to blades.
2. Remove blade bolt, lock washer and flat washer securing blade.
3. Install new or resharpened blade with trailing edge up towards deck as shown.

IMPORTANT: To ensure proper assembly, center hole in blade must align with star on mandrel assembly.

4. Reassemble blade bolt, lock washer and flat washer in exact order as shown.
5. Tighten blade bolt securely (27-35 Ft. Lbs. torque).

IMPORTANT: Blade bolt is heat treated. If bolt needs replacing, replace only with approve bolt shown in the Repair Parts.

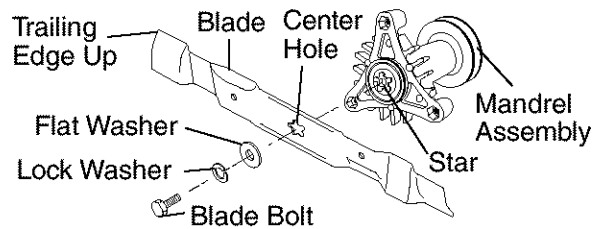

TO SHARPEN BLADE

NOTE: We do not recommend sharpening blade - but if you do, be sure the blade is balanced.

Care should be taken to keep the blade balanced. An unbalanced blade will cause excessive vibration and eventual damage to mower and engine.

- The blade can be sharpened with a file or on a grinding wheel. Do not attempt to sharpen while on the mower.
- To check blade balance, you will need a 5/8" diameter steel bolt, pin, or a cone balancer. (When using a cone balancer, follow the instructions supplied with balancer.)

NOTE: Do not use a nail for balancing blade. The lobes of the center hole may appear to be centered, but are not.

- Slide blade on to an unthreaded portion of the steel bolt or pin and hold the bolt or pin parallel with the ground. If blade is balanced, it should remain in a horizontal position. If either end of the blade moves downward, sharpen the heavy end until the blade is balanced.

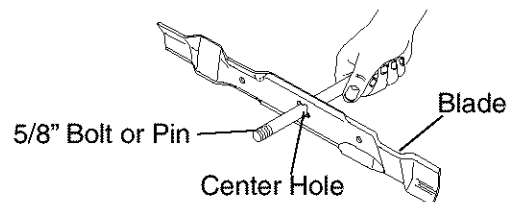

BATTERY

Your tractor has a battery charging system which is sufficient for normal use. However, periodic charging of the battery with an automotive charger will extend its life.

- Keep battery and terminals clean.
- Keep battery bolts tight.
- Keep small vent holes open.
- Recharge at 6-10 amperes for 1 hour.

NOTE: The original equipment battery on your tractor is maintenance free. Do not attempt to open or remove caps or covers. Adding or checking level of electrolyte is not necessary.

TO CLEAN BATTERY AND TERMINALS

Corrosion and dirt on the battery and terminals can cause the battery to “leak” power.

1. Disconnect BLACK battery cable first then RED battery cable and remove battery from tractor.
2. Rinse the battery with plain water and dry.
3. Clean terminals and battery cable ends with wire brush until bright.
4. Coat terminals with grease or petroleum jelly.
5. Reinstall battery (See “REPLACING BATTERY” in the Service and Adjustments section of this manual).

TRANSAXLE COOLING

The transmission fan and cooling fins should be kept clean to assure proper cooling.

Do not attempt to clean fan or transmission while engine is running or while the transmission is hot. To prevent possible damage to seals, do not use high pressure water or steam to clean transaxle.

- Inspect cooling fan to be sure fan blades are intact and clean.
- Inspect cooling fins for dirt, grass clippings and other materials. To prevent damage to seals, do not use compressed air or high pressure sprayer to clean cooling fins.

TRANSAXLE PUMP FLUID

The transaxle was sealed at the factory and fluid maintenance is not required for the life of the transaxle. Should the transaxle ever leak or require servicing, contact a Sears or other qualified service center.

V-BELTS

Check V-belts for deterioration and wear after 100 hours of operation and replace if necessary. The belts are not adjustable. Replace belts if they begin to slip from wear.

ENGINE

LUBRICATION

Only use high quality detergent oil rated with API service classification SF-SJ. Select the oil’s SAE viscosity grade according to your expected operating temperature.

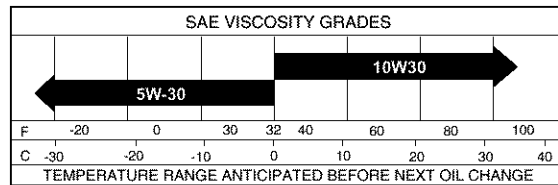

Change the oil after every 50 hours of operation or at least once a year if the tractor is not used for 50 hours in one year.

Check the crankcase oil level before starting the engine and after each eight (8) hours of operation.

TO CHANGE ENGINE OIL

Determine temperature range expected before oil change. All oil must meet API service classification SF-SJ.

- Be sure tractor is on level surface.
 - Oil will drain more freely when warm.
 - Catch oil in a suitable container.
1. Remove oil fill cap/dipstick. Be careful not to allow dirt to enter the engine when changing oil.
 2. Remove yellow cap from end of drain valve and install the drain tube onto the fitting.

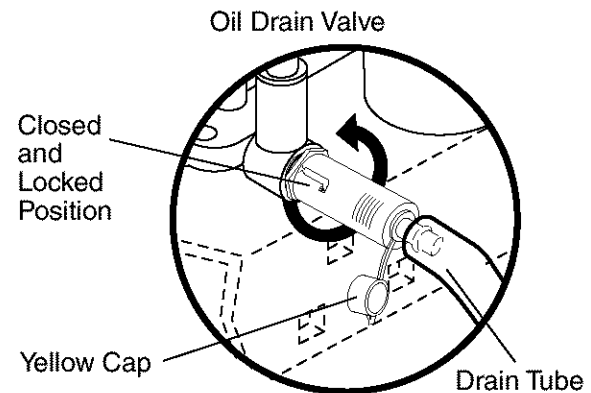

3. Unlock drain valve by pushing inward slightly and turning counterclockwise.
4. To open, pull out on the drain valve.
5. After oil has drained completely, close and lock the drain valve by pushing inward and turning clockwise until the pin is in the locked position as shown.
6. Remove the drain tube and replace the cap onto the end of the drain valve.
7. Refill engine with oil through oil fill dipstick tube. Pour slowly. Do not overfill. For approximate capacity see “PRODUCT SPECIFICATIONS” section of this manual.
8. Use gauge on oil fill cap/dipstick for checking level. Insert dipstick into the tube and rest the oil fill cap on the tube. Do not thread the cap onto the tube when taking reading. Keep oil at “FULL” line on dipstick. Tighten cap onto the tube securely when finished.

ENGINE OIL FILTER

Replace the engine oil filter every season or every other oil change if the tractor is used more than 100 hours in one year.

AIR FILTER

Your engine will not run properly using a dirty air filter. Clean the foam pre-cleaner after every 25 hours of operation or every season. Service paper cartridge every 100 hours of operation or every season, whichever occurs first.

Service air cleaner more often under dusty conditions.

1. Remove knob and cover.
2. Remove wing nut and air cleaner from base.

TO SERVICE PRE-CLEANER

3. Slide foam pre-cleaner off cartridge.
4. Wash it in liquid detergent and water.
5. Squeeze it dry in a clean cloth. Allow it to dry.
6. Saturate it in engine oil. Wrap it in clean, absorbent cloth and squeeze to remove excess oil.

TO SERVICE CARTRIDGE

1. Replace a dirty, bent, or damaged cartridge.

NOTE: Do not wash the paper cartridge or use pressurized air, as this will damage the cartridge.

2. Reinstall the pre-cleaner (cleaned and oiled) over the paper cartridge.
3. Reassemble air cleaner, wing nut, cover and tighten knob securely.

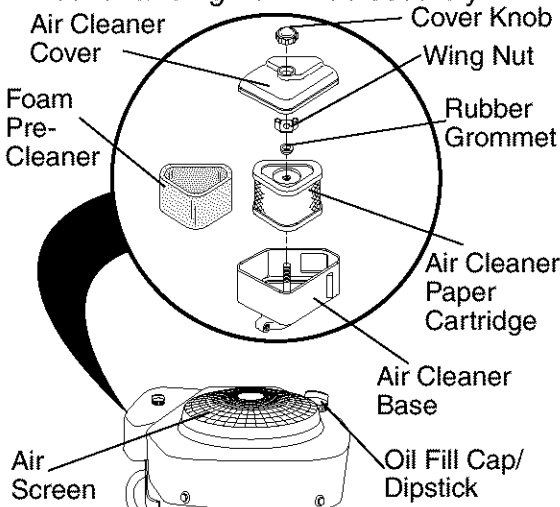

CLEAN AIR SCREEN

Air screen must be kept free of dirt and chaff to prevent engine damage from overheating. Clean with a wire brush or compressed air to remove dirt and stubborn dried gum fibers.

CLEAN AIR INTAKE/COOLING AREAS

To insure proper cooling, make sure the grass screen, cooling fins, and other external surfaces of the engine are kept clean at all times.

Every 100 hours of operation (more often under extremely dusty, dirty conditions), remove the blower housing and other cooling shrouds. Clean the cooling fins and external surfaces as necessary. Make sure the cooling shrouds are reinstalled.

NOTE: Operating the engine with a blocked grass screen, dirty or plugged cooling fins, and/or cooling shrouds removed will cause engine damage due to overheating.

MUFFLER

Inspect and replace corroded muffler and spark arrester (if equipped) as it could create a fire hazard and/or damage.

SPARK PLUG(S)

Replace spark plug(s) at the beginning of each mowing season or after every 100 hours of operation, whichever occurs first. Spark plug type and gap setting are shown in "PRODUCT SPECIFICATIONS" section of this manual.

IN-LINE FUEL FILTER

The fuel filter should be replaced once each season. If fuel filter becomes clogged, obstructing fuel flow to carburetor, replacement is required.

1. With engine cool, remove filter and plug fuel line sections.
2. Place new fuel filter in position in fuel line with arrow pointing towards carburetor.
3. Be sure there are no fuel line leaks and clamps are properly positioned.
4. Immediately wipe up any spilled gasoline.

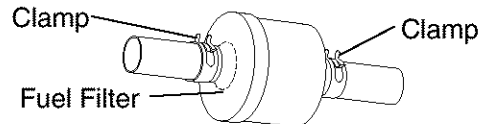

CLEANING

- Clean engine, battery, seat, finish, etc. of all foreign matter.
- Keep finished surfaces and wheels free of all gasoline, oil, etc.
- Protect painted surfaces with automotive type wax.

We do not recommend using a garden hose or pressure washer to clean your tractor unless the engine and transmission are covered to keep water out. Water in engine or transmission will shorten the useful life of your tractor. Use compressed air or a leaf blower to remove grass, leaves and trash from tractor and mower.

SERVICE AND ADJUSTMENTS



WARNING: TO AVOID SERIOUS INJURY, BEFORE PERFORMING ANY SERVICE OR ADJUSTMENTS:

1. Depress clutch/brake pedal fully and set parking brake.
2. Place motion control lever in neutral (N) position.
3. Place attachment clutch in "DISENGAGED" position.
4. Turn ignition key to "STOP" and remove key.
5. Make sure the blades and all moving parts have completely stopped.
6. Disconnect spark plug wire from spark plug and place wire where it cannot come in contact with plug.

TRACTOR

TO REMOVE MOWER

Mower will be easier to remove from the right side of tractor.

1. Place attachment clutch in "DISENGAGED" position.
2. Move attachment lift lever forward to lower mower to its lowest position.
3. Roll belt off engine pulley.
4. Remove small retainer spring, and remove clutch spring off pulley bolt.
5. Remove large retainer spring, slide collar off and push housing guide out of bracket.
6. Disconnect anti-sway bar from chassis bracket by removing retainer spring.
7. Disconnect suspension arms from rear deck brackets by removing retainer springs.
8. Disconnect front links from deck by removing retainer springs.
9. Raise lift lever to raise suspension arms. Slide mower out from under tractor.

IMPORTANT: If an attachment other than the mower deck is to be mounted on the tractor, remove the front links and hook the clutch spring into square hole in frame.

TO INSTALL MOWER

1. Raise attachment lift lever to its highest position.
2. Slide mower under tractor with deflector shield to right side of tractor.
3. Lower lift lever to its lowest position.
4. Connect front links to mower deck and secure with retainer springs.
5. Connect suspension arms to rear deck brackets and secure with retainer springs.
6. Connect anti-sway bar to chassis bracket and secure with retainer spring.
7. Push clutch cable housing guide into bracket, slide collar onto guide and secure with large retainer spring.
8. Place flat washer and clutch spring on idler pulley bolt and secure with small retainer spring.
9. Install belt onto engine pulley.

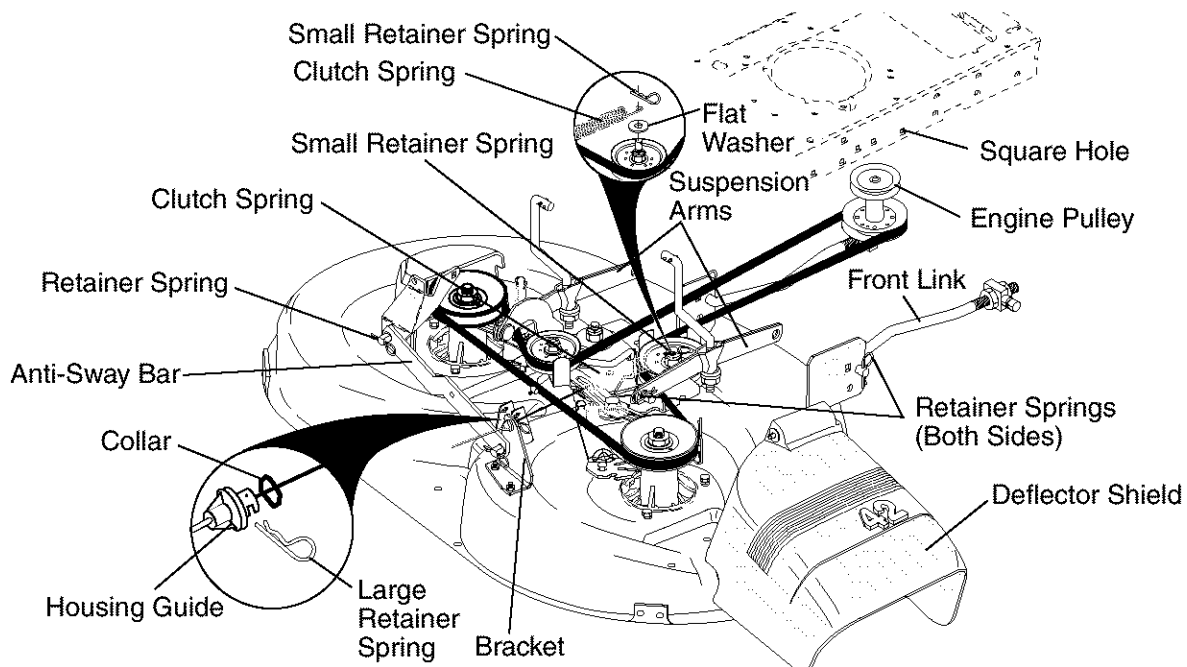

TO LEVEL MOWER HOUSING

Adjust the mower while tractor is parked on level ground or driveway. Make sure tires are properly inflated (See "PRODUCT SPECIFICATIONS" section of this manual). If tires are over or underinflated, you will not properly adjust your mower.

SIDE-TO-SIDE ADJUSTMENT

- Raise mower to its highest position.
- At the midpoint of both sides of mower, measure height from bottom edge of mower to ground. Distance "A" on both sides of mower should be the same or within 1/4" of each other.
- If adjustment is necessary, make adjustment on one side of mower only.
- To raise one side of mower, tighten lift link adjustment nut on that side.
- To lower one side of mower, loosen lift link adjustment nut on that side.

NOTE: Each full turn of adjustment nut will change mower height about 1/8".

- Recheck measurements after adjusting.

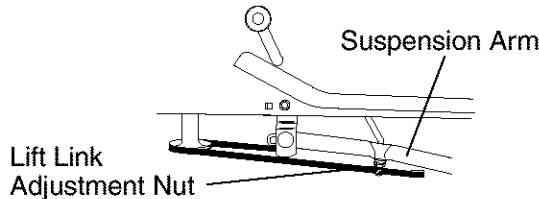
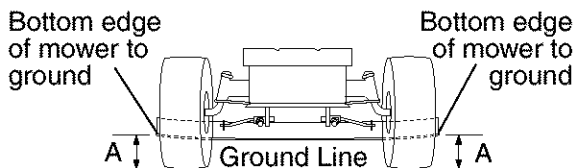

FRONT-TO-BACK ADJUSTMENT

IMPORTANT: Deck must be level side-to-side. If the following front-to-back adjustment is necessary, be sure to adjust both front links equally so mower will stay level side-to-side.

To obtain the best cutting results, the mower housing should be adjusted so that the front is approximately 1/8" to 1/2" lower than the rear when the mower is in its highest position.

Check adjustment on right side of tractor. Measure distance "D" directly in front and behind the mandrel at bottom edge of mower housing as shown.

- Before making any necessary adjustments, check that both front links are equal in length.
- If links are not equal in length, adjust one link to same length as other link.
- To lower front of mower loosen nut "E" on both front links an equal number of turns.

- When distance "D" is 1/8" to 1/2" lower at front than rear, tighten nuts "F" against trunnion on both front links.
- To raise front of mower, loosen nut "F" from trunnion on both front links. Tighten nut "E" on both front links an equal number of turns. The two front links must remain equal in length.
- When distance "D" is 1/8" to 1/2" lower at front than rear, tighten nut "F" against trunnion on both front links.
- Recheck side-to-side adjustment.

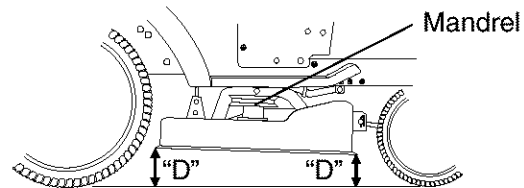

Both Front Links Should be Equal in Length

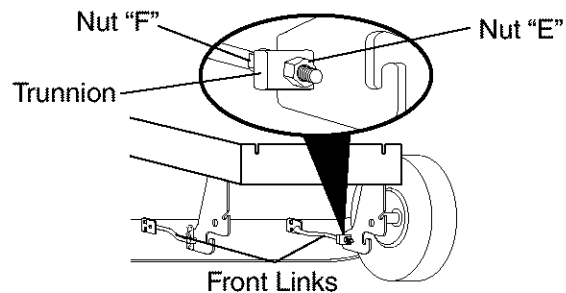
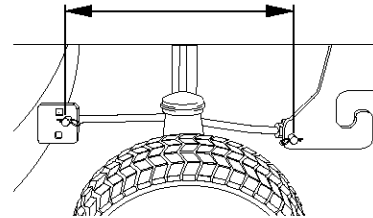

TO REPLACE MOWER BLADE DRIVE BELT

The mower blade drive belt may be replaced without tools. Park the tractor on level surface. Engage parking brake.

BELT REMOVAL -

1. Remove mower from tractor (See "TO REMOVE MOWER" in this section of manual).
2. Work belt off both mandrel pulleys and idler pulleys.
3. Pull belt away from mower.

BELT INSTALLATION -

1. Work belt around both mandrel pulleys and idler pulleys
2. Make sure belt is in all pulley grooves and inside all belt guides.
3. Install mower (See "To Install Mower" in this section of this manual).

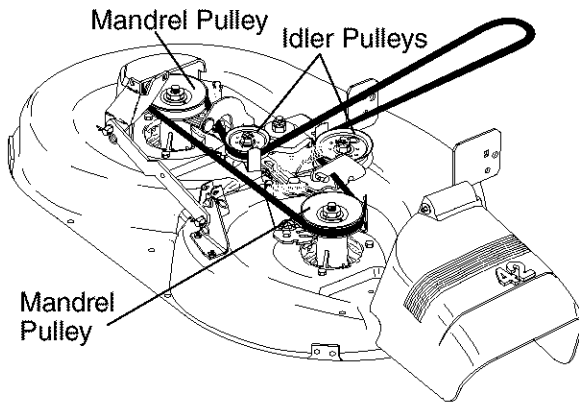

TO CHECK AND ADJUST BRAKE

Your tractor is equipped with an adjustable brake system which is mounted on the right side of the transaxle.

If tractor requires more than five (5) feet to stop at highest speed in highest gear on a level, dry concrete or paved surface, then brake must be checked and adjusted.

TO CHECK BRAKE

1. Park tractor on a level, dry concrete or paved surface, depress clutch/brake pedal all the way down and engage parking brake.
2. Disengage transmission by placing freewheel control in "transmission disengaged" position. Pull freewheel control out and into the slot and release so it is held in the disengaged position.

The rear wheels must lock and skid when you try to manually push the tractor forward. If the rear wheels rotate, the brake needs to be adjusted or the pads need to be replaced.

TO ADJUST BRAKE

1. Depress clutch/brake pedal all the way down and engage parking brake.
2. Measure distance between brake operating arm and nut "A" on brake rod.
3. If distance is other than 1-9/16", loosen jam nut and turn nut "A" until distance becomes 1-9/16". Retighten jam nut against nut "A".
4. Engage transmission by placing freewheel control in "transmission engaged" position.
5. Road test tractor for proper stopping distance as stated above. Readjust if necessary. If stopping distance is still greater than five (5) feet in highest gear, further maintenance is necessary. Replace brake pads or contact a Sears or other qualified service center.

With parking brake "Engaged"

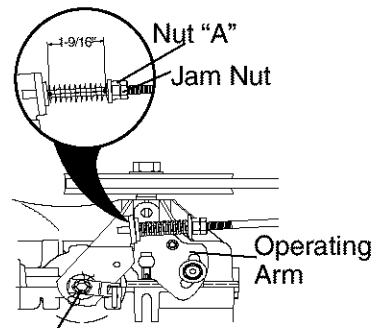

Do not touch this nut. If further brake adjustment is necessary contact a Sears or other qualified service center.

TO REPLACE MOTION DRIVE BELT

Park the tractor on level surface. Engage parking brake. For assistance, there is a belt installation guide decal on bottom side of left footrest.

BELT REMOVAL -

1. Remove mower (See "TO REMOVE MOWER" in this section of manual).
- NOTE:** Observe entire motion drive belt and position of all belt guides and keepers.
2. Remove belt from stationary idler and clutching idler.
3. Remove belt downward from around engine pulley.
4. Pull belt slack toward rear of tractor. Carefully remove belt upwards from transmission input pulley and over cooling fan blades.
5. Remove belt from center span keeper and pull belt away from tractor.

BELT INSTALLATION -

1. Carefully work new belt down around transmission cooling fan and onto the input pulley.
2. Slide belt into the center span keeper.
3. Pull belt toward front of tractor and roll around the top groove of engine pulley.
4. Install belt through stationary idler and clutching idler.
5. Make sure belt is in all pulley grooves and inside all belt guides and keepers.
6. Install mower (See "TO INSTALL MOWER" in this section of manual).

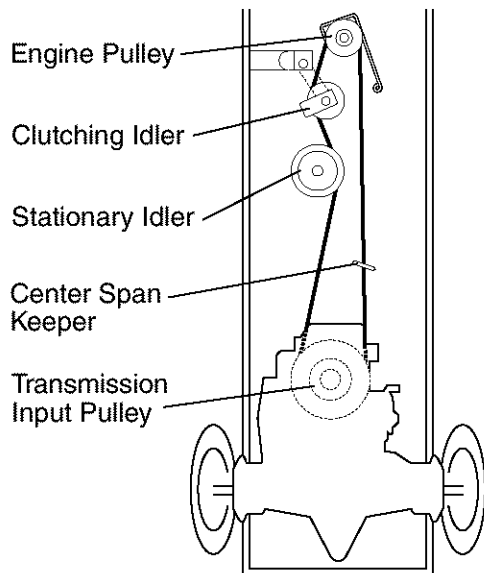

TRANSAXLE MOTION CONTROL LEVER NEUTRAL ADJUSTMENT

The motion control lever has been preset at the factory and adjustment should not be necessary.

1. Loosen adjustment bolt in front of the right rear wheel, and lightly tighten.
2. Start engine and move motion control lever until tractor does not move forward or backward.
3. Hold motion control lever in that position and turn engine off.
4. While holding motion control lever in place, loosen the adjustment bolt.
5. Move motion control lever to the neutral (N) (lock gate) position.
6. Tighten adjustment bolt securely.

NOTE: If additional clearance is needed to get to adjustment bolt, move mower deck height to the lowest position. After above adjustment is made, if the tractor still creeps forward or backward while motion control lever is in neutral position, follow these steps:

1. Loosen the adjustment bolt.
2. Move the motion control lever 1/4 to 1/2 inch in the direction it is trying to creep.
3. Tighten adjustment bolt securely.
4. Start engine and test.
5. If tractor still creeps, repeat above steps until satisfied.

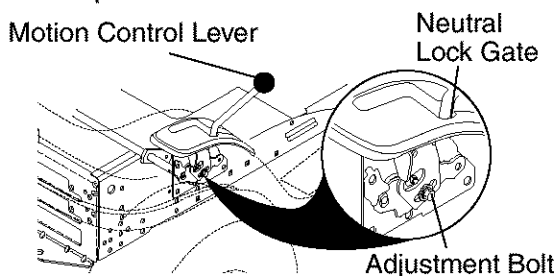

TRANSMISSION REMOVAL/REPLACEMENT

Should your transmission require removal for service or replacement, it should be purged after reinstallation and before operating the tractor. See "PURGE TRANSMISSION" in the Operation section of this manual.

TO ADJUST STEERING WHEEL ALIGNMENT

If steering wheel crossbars are not horizontal (left to right) when wheels are positioned straight forward, remove steering wheel and reassemble with crossbars horizontal. Tighten securely.

FRONT WHEEL TOE-IN/CAMBER

The front wheel toe-in and camber are not adjustable on your tractor. If damage has occurred to affect the front wheel toe-in or camber, contact a Sears or other qualified service center.

TO REMOVE WHEEL FOR REPAIRS

1. Block up axle securely.
2. Remove axle cover, retaining ring and washers to allow wheel removal (rear wheels have a square key - Do not lose).

3. Repair tire and reassemble.

NOTE: On rear wheels only: align grooves in rear wheel hub and axle. Insert square key.

4. Replace washers and snap retaining ring securely in axle groove.
5. Replace axle cover.

NOTE: To seal tire punctures and prevent flat tires due to slow leaks, purchase and use tire sealant from Sears. Tire sealant also prevents tire dry rot and corrosion.

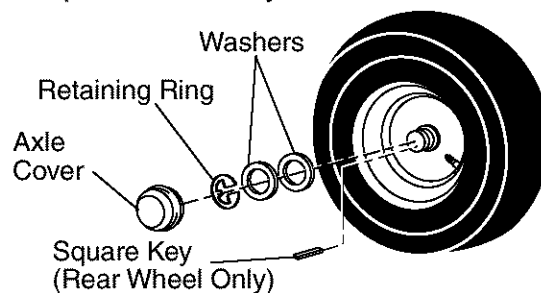

TO START ENGINE WITH A WEAK BATTERY

⚠ WARNING: Lead-acid batteries generate explosive gases. Keep sparks, flame and smoking materials away from batteries. Always wear eye protection when around batteries.

If your battery is too weak to start the engine, it should be recharged. (See "BATTERY" in the MAINTENANCE section of this manual).

If “jumper cables” are used for emergency starting, follow this procedure:

IMPORTANT: Your tractor is equipped with a 12 volt system. The other vehicle must also be a 12 volt system. Do not use your tractor battery to start other vehicles.

TO ATTACH JUMPER CABLES -

1. Connect one end of the RED cable to the POSITIVE (+) terminal of each battery(A-B), taking care not to short against tractor chassis.
2. Connect one end of the BLACK cable to the NEGATIVE (-) terminal (C) of fully charged battery.
3. Connect the other end of the BLACK cable (D) to good chassis ground, away from fuel tank and battery.

TO REMOVE CABLES, REVERSE ORDER -

1. BLACK cable first from chassis and then from the fully charged battery.
2. RED cable last from both batteries.

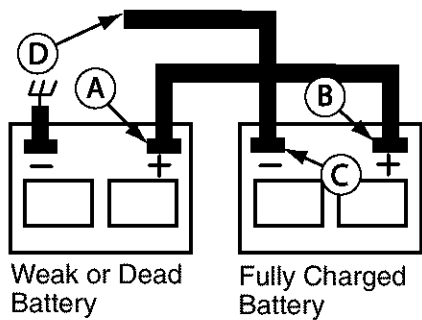

REPLACING BATTERY

⚠ WARNING: Do not short battery terminals by allowing a wrench or any other object to contact both terminals at the same time. Before connecting battery, remove metal bracelets, wristwatch bands, rings, etc.

Positive terminal must be connected first to prevent sparking from accidental grounding.

1. Lift seat pan to raised position.
2. Disconnect BLACK battery cable first then RED battery cable and carefully remove battery from tractor.
3. Install new battery with terminals in same position as old battery.
4. First connect RED battery cable to positive (+) terminal with hex bolt and keps nut as shown. Tighten securely. Slide terminal cover over terminal
5. Connect BLACK grounding cable to negative (-) terminal with remaining hex bolt and keps nut. Tighten securely.

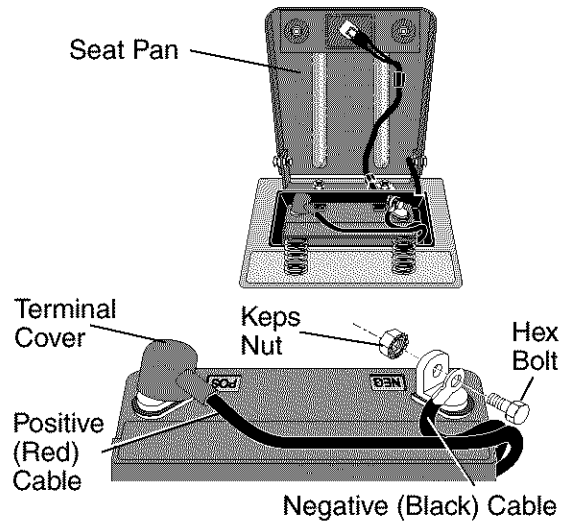

TO REPLACE HEADLIGHT BULB

1. Raise hood.
2. Pull bulb holder out of the hole in the backside of the grill.
3. Replace bulb in holder and push bulb holder securely back into the hole in the backside of the grill.
4. Close hood.

INTERLOCKS AND RELAYS

Loose or damaged wiring may cause your tractor to run poorly, stop running, or prevent it from starting.

- Check wiring. See electrical wiring diagram in the Repair Parts section.

TO REPLACE FUSE

Replace with 20 amp automotive-type plug-in fuse. The fuse holder is located behind the dash.

TO REMOVE HOOD AND GRILL ASSEMBLY

1. Raise hood.
2. Unsnap headlight wire connector.
3. Stand in front of tractor. Grasp hood at sides, tilt toward engine and lift off of tractor.
4. When replacing hood, be sure to re-connect the headlight wire connector.

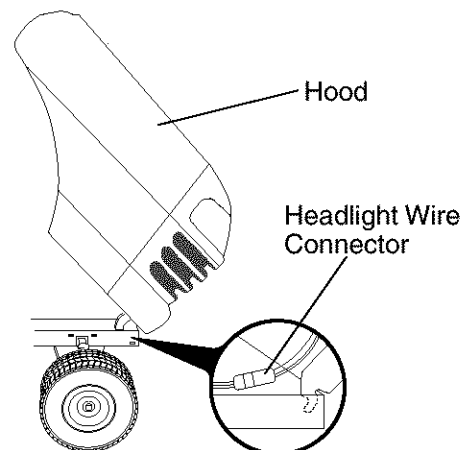

ENGINE

Maintenance, repair, or replacement of the emission control devices and systems, which are being done at the customer's expense, may be performed by any non-road engine repair establishment or individual. Warranty repairs must be performed by an authorized engine manufacturer's service outlet.

TO ADJUST THROTTLE CONTROL CABLE

The throttle control has been preset at the factory and adjustment should not be necessary. Check adjustment as described below before loosening cable. If adjustment is necessary, proceed as follows:

1. With engine not running, move throttle control lever from slow to choke position. Slowly move lever from choke to fast position.
2. Check to see if hole in throttle lever and hole in speed control bracket are aligned.
3. If holes are not aligned, loosen cable clamp screw and align the holes by inserting a pencil or a 1/4" drill bit through both holes.
4. Pull throttle cable up to remove slack and tighten cable clamp screw. Remove alignment pencil or drill bit.

TO ADJUST CARBURETOR

The carburetor has been preset at the factory and adjustment should not be necessary. However, minor adjustment may be required to compensate for differences in fuel, temperature, altitude or load. If the carburetor does need adjustment, proceed as follows:

In general, turning the adjusting needles **in** (clockwise) decreases the supply of fuel to the engine giving a leaner fuel/air mixture. Turning the adjusting needles **out** (counterclockwise) increases the supply of fuel to the engine giving a richer fuel/air mixture.

IMPORTANT: Damage to the needles and seats in carburetor may result if turned in too tight.

NOTE: The carburetor on this engine is low emission. It is equipped with an idle fuel adjusting needle with a limiter cap, which allows some adjustment within the limits allowed by the cap. Do not attempt to remove the limiter cap. The limiter cap cannot be removed without breaking the adjusting needle.

1. Be sure you have a clean air filter and the throttle control cable is adjusted properly (see above).

2. Start engine and allow to warm for five minutes. Make adjustments with engine running and shift/motion control lever in neutral (N) position.
3. Idle speed setting - With throttle control lever in slow position, engine should idle at 1750 RPM. If engine idles too slow or fast, turn idle speed adjusting screw in or out until correct idle is attained.
4. Idle fuel needle setting - With throttle control lever in slow position, turn idle fuel adjustment needle **in** (clockwise) until engine begins to die and then turn **out** (counterclockwise) until engine runs rough. Turn needle to a point midway between those two positions.
5. Recheck idle speed. Readjust if necessary.

ACCELERATION TEST -

6. Move throttle control lever from slow to fast position. If engine hesitates or dies, turn idle fuel adjusting needle **out** (counterclockwise) 1/8 turn. Repeat test and continue to adjust, if necessary, until engine accelerates smoothly.

High speed stop is factory adjusted. Do not adjust - damage may result.

IMPORTANT: Never tamper with the engine governor, which is factory set for proper engine speed. Overspeeding the engine above the factory high speed setting can be dangerous. If you think the engine-governed high speed needs adjusting, contact a Sears or other qualified service center, which has proper equipment and experience to make any necessary adjustments.

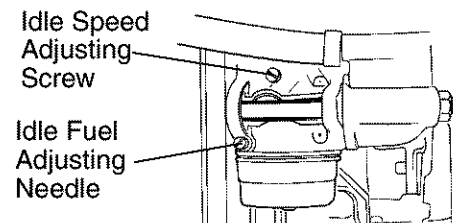
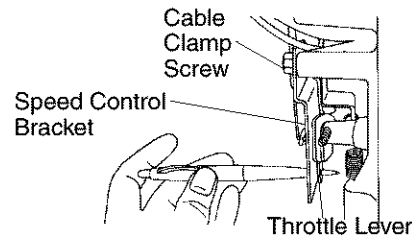

STORAGE

Immediately prepare your tractor for storage at the end of the season or if the tractor will not be used for 30 days or more.

⚠ WARNING: Never store the tractor with gasoline in the tank inside a building where fumes may reach an open flame or spark. Allow the engine to cool before storing in any enclosure.

TRACTOR

Remove mower from tractor for winter storage. When mower is to be stored for a period of time, clean it thoroughly, remove all dirt, grease, leaves, etc. Store in a clean, dry area.

1. Clean entire tractor (See "CLEANING" in the Maintenance section of this manual).
2. Inspect and replace belts, if necessary (See belt replacement instructions in the Service and Adjustments section of this manual).
3. Lubricate as shown in the Maintenance section of this manual.
4. Be sure that all nuts, bolts and screws are securely fastened. Inspect moving parts for damage, breakage and wear. Replace if necessary.
5. Touch up all rusted or chipped paint surfaces; sand lightly before painting.

BATTERY

- Fully charge the battery for storage.
- After a period of time in storage, battery may require recharging.
- To help prevent corrosion and power leakage during long periods of storage, battery cables should be disconnected and battery cleaned thoroughly (see "TO CLEAN BATTERY AND TERMINALS" in the Maintenance section of this manual).
- After cleaning, leave cables disconnected and place cables where they cannot come in contact with battery terminals.
- If battery is removed from tractor for storage, do not store battery directly on concrete or damp surfaces.

ENGINE

FUEL SYSTEM

IMPORTANT: It is important to prevent gum deposits from forming in essential fuel system parts such as carburetor, fuel hose, or tank during storage.

Also, alcohol blended fuels (called gasohol or using ethanol or methanol) can attract moisture which leads to separation and formation of acids during storage. Acidic gas can damage the fuel system of an engine while in storage.

- Empty the fuel tank by starting the engine and letting it run until the fuel lines and carburetor are empty.
- Never use engine or carburetor cleaner products in the fuel tank or permanent damage may occur.
- Use fresh fuel next season.

NOTE: Fuel stabilizer is an acceptable alternative in minimizing the formation of fuel gum deposits during storage. Add stabilizer to gasoline in fuel tank or storage container. Always follow the mix ratio found on stabilizer container. Run engine at least 10 minutes after adding stabilizer to allow the stabilizer to reach the carburetor. Do not empty the gas tank and carburetor if using fuel stabilizer.

ENGINE OIL

Drain oil (with engine warm) and replace with clean engine oil. (See "ENGINE" in the Maintenance section of this manual).

CYLINDER(S)

1. Remove spark plug(s).
2. Pour one ounce of oil through spark plug hole(s) into cylinder(s).
3. Turn ignition key to start position for a few seconds to distribute oil.
4. Replace with new spark plug(s).

OTHER

- Do not store gasoline from one season to another.
- Replace your gasoline can if your can starts to rust. Rust and/or dirt in your gasoline will cause problems.
- If possible, store your tractor indoors and cover it to give protection from dust and dirt.
- Cover your tractor with a suitable protective cover that does not retain moisture. Do not use plastic. Plastic cannot breathe which allows condensation to form and will cause your tractor to rust.

IMPORTANT: Never cover tractor while engine and exhaust areas are still warm.

TROUBLESHOOTING CHART:

See appropriate section in manual unless directed to Sears service center

PROBLEM	CAUSE	CORRECTION
Will not start	<ol style="list-style-type: none"> 1. Out of fuel. 2. Engine not "CHOKED" properly. 3. Engine flooded. 4. Bad spark plug. 5. Dirty air filter. 6. Dirty fuel filter. 7. Water in fuel. 8. Loose or damaged wiring. 9. Carburetor out of adjustment. 10. Engine valves out of adjustment. 	<ol style="list-style-type: none"> 1. Fill fuel tank. 2. See "TO START ENGINE" in Operation section. 3. Wait several minutes before attempting to start. 4. Replace spark plug. 5. Clean/replace air filter. 6. Replace fuel filter. 7. Empty fuel tank and carburetor, refill tank with fresh gasoline and replace fuel filter. 8. Check all wiring. 9. See "To Adjust Carburetor" in Service and Adjustments section. 10. Contact a Sears or other qualified service center.
Hard to start	<ol style="list-style-type: none"> 1. Dirty air filter. 2. Bad spark plug. 3. Weak or dead battery. 4. Dirty fuel filter. 5. Stale or dirty fuel. 6. Loose or damaged wiring. 7. Carburetor out of adjustment. 8. Engine valves out of adjustment. 	<ol style="list-style-type: none"> 1. Clean/replace air filter. 2. Replace spark plug. 3. Recharge or replace battery. 4. Replace fuel filter. 5. Empty fuel tank and refill tank with fresh, clean gasoline. 6. Check all wiring. 7. See "To Adjust Carburetor" in Service and Adjustments section. 8. Contact a Sears or other qualified service center.
Engine will not turn over	<ol style="list-style-type: none"> 1. Brake pedal not depressed. 2. Attachment clutch is engaged. 3. Weak or dead battery. 4. Blown fuse. 5. Corroded battery terminals. 6. Loose or damaged wiring. 7. Faulty ignition switch. 8. Faulty solenoid or starter. 9. Faulty operator presence switch(es). 	<ol style="list-style-type: none"> 1. Depress brake pedal. 2. Disengage attachment clutch. 3. Recharge or replace battery. 4. Replace fuse. 5. Clean battery terminals. 6. Check all wiring. 7. Check/replace ignition switch. 8. Check/replace solenoid or starter. 9. Contact a Sears or other qualified service center.
Engine clicks but will not start	<ol style="list-style-type: none"> 1. Weak or dead battery. 2. Corroded battery terminals. 3. Loose or damaged wiring. 4. Faulty solenoid or starter. 	<ol style="list-style-type: none"> 1. Recharge or replace battery. 2. Clean battery terminals. 3. Check all wiring. 4. Check/replace solenoid or starter.
Loss of power	<ol style="list-style-type: none"> 1. Cutting too much grass/too fast. 2. Throttle in "CHOKE" position. 3. Build-up of grass, leaves and trash under mower. 4. Dirty air filter. 5. Low oil level/dirty oil. 	<ol style="list-style-type: none"> 1. Raise cutting height/reduce speed. 2. Adjust throttle control. 3. Clean underside of mower housing. 4. Clean/replace air filter. 5. Check oil level/change oil.

TROUBLESHOOTING CHART:

See appropriate section in manual unless directed to Sears service center

PROBLEM	CAUSE	CORRECTION
Loss of power (continued)	5. Low oil level/dirty oil. 6. Faulty spark plug. 7. Dirty fuel filter. 8. Stale or dirty fuel. 9. Water in fuel. 10. Spark plug wire loose. 11. Dirty engine air screen/fins. 12. Dirty/clogged muffler. 13. Loose or damaged wiring. 14. Carburetor out of adjustment. 15. Engine valves out of adjustment.	5. Check oil level/change oil. 6. Clean and regap or change spark plug. 7. Replace fuel filter. 8. Empty fuel tank and refill tank with fresh, clean gasoline. 9. Empty fuel tank and carburetor, refill tank with fresh gasoline and replace fuel filter. 10. Connect and tighten spark plug wire. 11. Clean engine air screen/fins. 12. Clean/replace muffler. 13. Check all wiring. 14. See "To Adjust Carburetor" in Service and Adjustments section. 15. Contact a Sears or other qualified service center.
Excessive vibration	1. Worn, bent or loose blade. 2. Bent blade mandrel. 3. Loose/damaged part(s).	1. Replace blade. Tighten blade bolt. 2. Contact a Sears or other qualified service center. 3. Tighten loose part(s). Replace damaged parts.
Engine continues to run when operator leaves seat with attachment clutch engaged	1. Faulty operator-safety presence control system.	1. Check wiring, switches and connections. If not corrected, contact a Sears or other qualified service center.
Poor cut - uneven	1. Worn, bent or loose blade. 2. Mower deck not level. 3. Buildup of grass, leaves, and trash under mower. 4. Bent blade mandrel. 5. Clogged mower deck vent from build-up of grass, leaves, and trash around mandrels.	1. Replace blade. Tighten blade bolt. 2. Level mower deck. 3. Clean underside of mower housing. 4. Contact a Sears or other qualified service center. 5. Clean around mandrels to open vent holes.
Mower blades will not rotate	1. Obstruction in clutch mechanism. 2. Worn/damaged mower drive belt. 3. Frozen idler pulley. 4. Frozen blade mandrel.	1. Remove obstruction. 2. Replace mower drive belt. 3. Replace idler pulley. 4. Contact a Sears or other qualified service center.

TROUBLESHOOTING CHART:

See appropriate section in manual unless directed to Sears service center

PROBLEM	CAUSE	CORRECTION
Poor grass discharge	<ol style="list-style-type: none"> 1. Engine speed too slow. 2. Travel speed too fast. 3. Wet grass. 4. Mower deck not level. 5. Low/uneven tire air pressure. 6. Worn, bent or loose blade. 7. Buildup of grass, leaves and trash under mower. 8. Mower drive belt worn. 9. Blades improperly installed. 10. Improper blades used. 11. Clogged mower deck vent holes from buildup of grass, leaves, and trash around mandrels. 	<ol style="list-style-type: none"> 1. Place throttle control in "FAST" position. 2. Shift to slower speed. 3. Allow grass to dry before mowing. 4. Level mower deck. 5. Check tires for proper air pressure. 6. Replace/sharpen blade. Tighten blade bolt. 7. Clean underside of mower housing. 8. Replace mower drive belt. 9. Reinstall blades sharp edge down. 10. Replace with blades listed in this manual. 11. Clean around mandrels to open vent holes.
Headlight(s) not working (if so equipped)	<ol style="list-style-type: none"> 1. Switch is "OFF". 2. Bulb(s) or lamp(s) burned out. 3. Faulty light switch. 4. Loose or damaged wiring. 5. Blown fuse. 	<ol style="list-style-type: none"> 1. Turn switch "ON". 2. Replace bulb(s) or lamp(s). 3. Check/replace light switch. 4. Check wiring and connections. 5. Replace fuse.
Battery will not charge	<ol style="list-style-type: none"> 1. Bad battery cell(s). 2. Poor cable connections. 3. Faulty regulator (if so equipped). 4. Faulty alternator. 	<ol style="list-style-type: none"> 1. Replace battery. 2. Check/clean all connections. 3. Replace regulator. 4. Replace alternator.
Loss of drive	<ol style="list-style-type: none"> 1. Freewheel control in "disengaged" position. 2. Motion drive belt worn, damaged, or broken. 3. Air trapped in transmission during shipment or servicing. 	<ol style="list-style-type: none"> 1. Place freewheel control in "engaged" position. 2. Replace motion drive belt. 3. Purge transmission.
Engine "backfires" when turning engine "OFF"	<ol style="list-style-type: none"> 1. Engine throttle control not set at "SLOW" position for 30 seconds before stopping engine. 	<ol style="list-style-type: none"> 1. Move throttle control to "SLOW" position and allow to idle for 30 seconds before stopping engine.

SERVICE NOTES

TRACTOR - - MODEL NUMBER 917.273160

SCHEMATIC

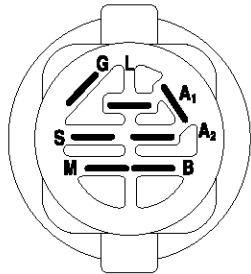
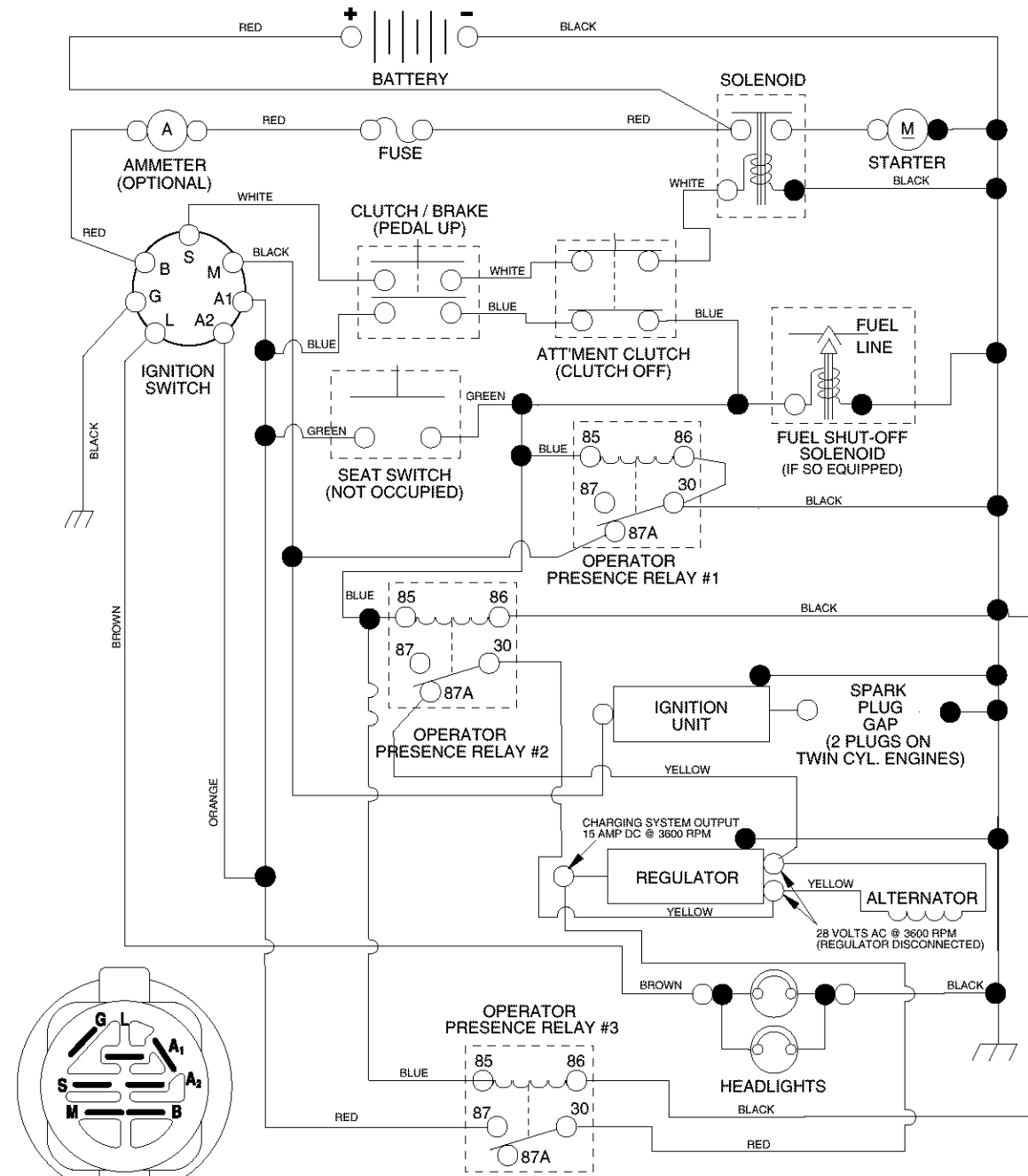

IGNITION SWITCH

POSITION	CIRCUIT	"MAKE"
OFF	M+G+A1	NONE
RUN/LIGHT	B+A1	A2+L
RUN	B+A1	NONE
START	B + S + A1	NONE

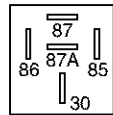

RELAY

● NON-REMOVABLE CONNECTIONS
○ REMOVABLE CONNECTIONS

WIRING INSULATED CLIPS

NOTE: IF WIRING INSULATED CLIPS WERE REMOVED FOR SERVICING OF UNIT, THEY SHOULD BE REPLACED TO PROPERLY SECURE YOUR WIRING.

ELECTRICAL**TRACTOR - - MODEL NUMBER 917.273160**

KEY PART NO.	PART NO.	DESCRIPTION
1	163465	Battery
2	74760412	Bolt Hex Hd 1/4-20unc x 3/4
8	176689	Box Battery
16	176137	Switch, Interlock
21	183759	Harness Asm Light W/4152j
22	4152J	Bulb Light #1156
24	4799J	Cable Battery 6 Ga 11" red
25	146147	Cable Battery 6 Ga w/16 wire red
26	175158	Fuse
27	73510400	Nut Keps Hex 1/4-20 Unc
28	4207J	Cable Ground 6 Ga 12" black
29	160784	Switch Plunger Normal Op Olive
30	175566	Switch Ign
33	140403	Key Ign
40	179722	Harness Ign
41	71110408	Bolt Blk. Fin Hex 1/4-20 Unc x 1/2
42	131563	Cover Terminal Red
43	178861	Solenoid
45	122822X	Ammeter Rectangular 15 Amp
52	141940	Protection Wire Loop
81	109748X	Relay Asm
90	180449	Cover Terminal

NOTE: All component dimensions given in U.S. inches
1 inch = 25.4 mm

TRACTOR - - MODEL NUMBER 917.273160

CHASSIS AND ENCLOSURES

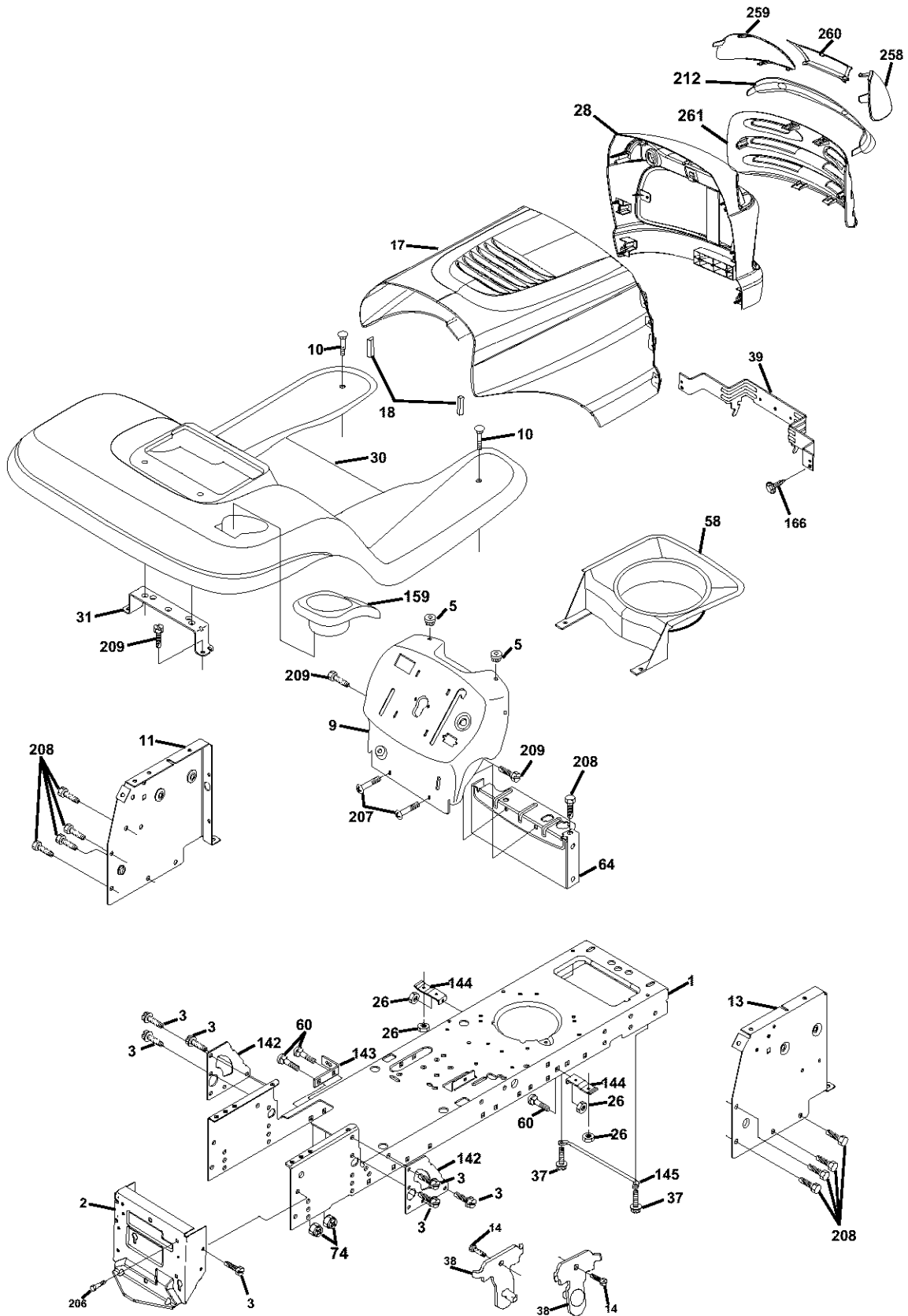

TRACTOR - - MODEL NUMBER 917.273160
CHASSIS AND ENCLOSURES

KEY NO.	PART NO.	DESCRIPTION
1	174619	Chassis
2	176554	Drawbar
3	17060612	Screw 3/8-16 x 3/4
5	155272	Bumper Hood/Dash
9	168337X013	Dash
10	STD533710	Bolt, Carriage 3/8-16 x 3/4
11	174996	Panel, Dash, L.H.
13	172105X010	Panel, Dash, R.H.
14	17490608	Screw Thdrol 3/8-16 x 1/2
17	185682X613	Hood Assembly
18	184921	Bumper Hood
26	STD541437	Nut
28	184247	Grille
30	175692X613	Fend/Ftrest
31	139976	Bracket, Fender Support
37	17490508	Screw Thdrol 5/16-18 x 1/2
38	175710	Pivot Bracket Assembly, Rear
39	174714	Bracket Pivot Laser Lt
58	150127	Duct Air Engine
60	72140606	Bolt Rdhd Sqnk 3/8-16 UNC x 1
64	154798	Dash Lower STLT
74	STD541437	Nut Crownlock 3/8016 UNC
142	175702	Plate Reinforcement STLT
143	154966	Bracket Swaybar Chassis
144	175582	Bracket Pnt Footrest STLT
145	156524	Rod Pivot Chassis/Hood
159	155123X428	Cupholder Stilt Black
166	171875	Screw Hwhd Hi-Lo #13-16 x 3/4
206	170165	Bolt Shoulder 5/16-18 TT
207	17670508	Screw Thdrol 5/16-18 x 1/2 Tytt
209	17000612	Screw Hexwsh Thdr 3/8-16 x 3/4
212	184248	Insert Lens Reflective
258	184245X599	Lens Laser RH
259	184246X599	Lens Laser LH
260	184250X428	Cover Lens Laser
261	184258X428	Insert Grille Laser
--	5479J	Plug, Button

NOTE: All component dimensions given in U.S. inches
1 inch = 25.4 mm

TRACTOR - - MODEL NUMBER 917.273160
GROUND DRIVE

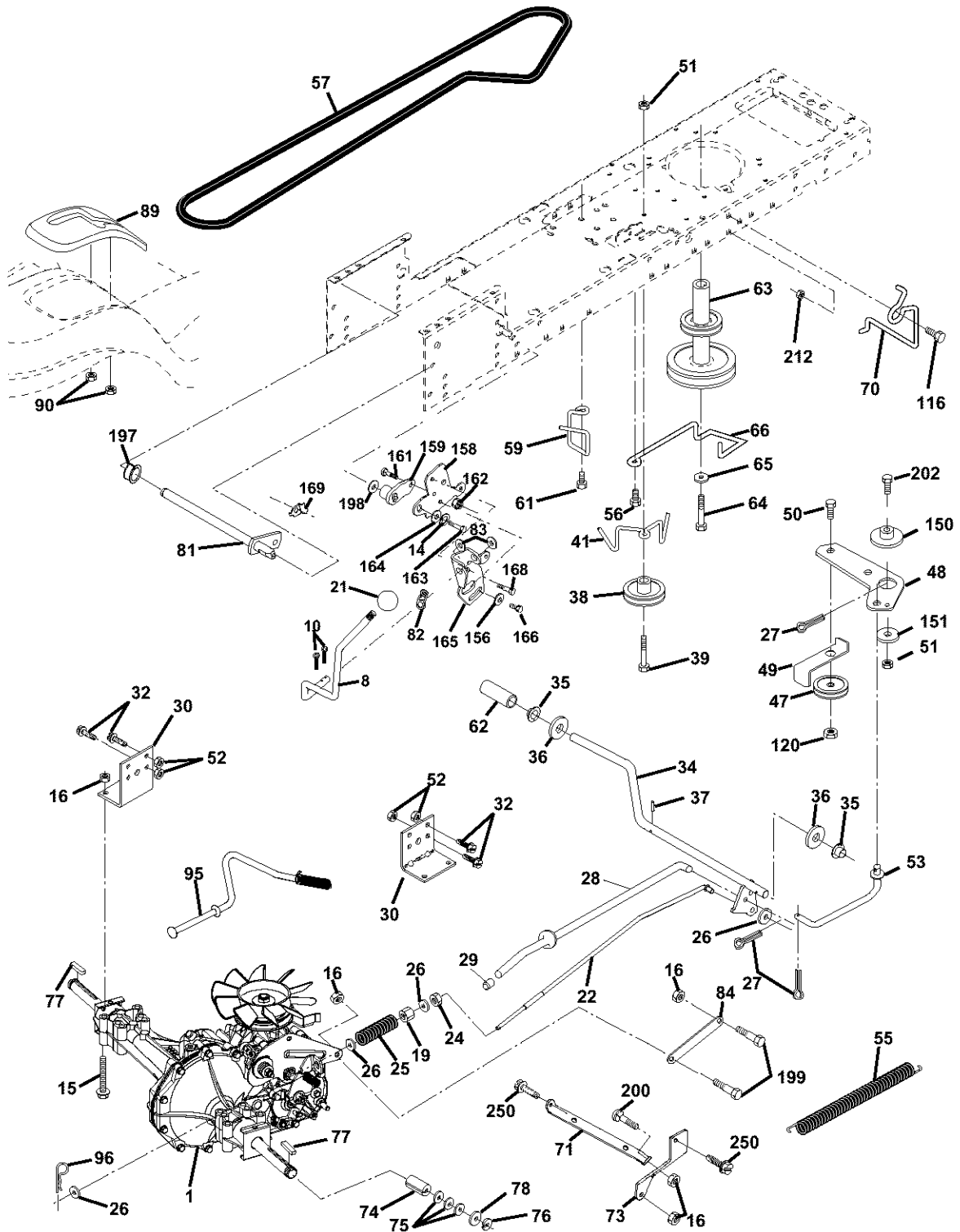

TRACTOR - - MODEL NUMBER 917.273160

GROUND DRIVE

KEY NO.	PART NO.	DESCRIPTION	KEY NO.	PART NO.	DESCRIPTION
1	-----	Transmission (See Breakdown) Hydro Gear Model 314-0510	70	134683	Guide, Belt, Mower Drive RH
8	165866	Rod, Shift	71	169183	Strap, Torque, Lh
10	STD561210	Pin, Cotter 1/8 x 1	73	169182	Strap, Torque, Rh
14	STD551125	Washer Lock 1/4	74	137057	Spacer, Axle
15	74490544	Bolt Hex Flghd 5/16-18 Gr. 5	75	121749X	Washer 25/32 x 1-1/4 x 16 Ga.
16	73800500	Nut, Lock Hex w/Ins 5/16-18 unc	76	12000001	Ring, E
19	73800600	Nut Lock Hex w/Ins 3/8-16	77	123583X	Key, Square
21	130564	Knob	78	121748X	Washer 25/32 x 1-5/8 x 16 Ga.
22	169498	Rod, Brake	81	165596	Shaft Asm Cross
24	73350600	Nut	82	165711	Spring, Torsion
25	106888X	Spring, Rod, Brake	83	19171216	Washer 17/32 x 3/4 x 16 Ga.
26	19131316	Washer 13/32 x 13/16 x 16 Ga.	84	169594	Link Transaxle
27	STD561210	Pin, Cotter 1/8 x 3/4	89	164890X428	Console, Shift
28	175765	Rod, Parking Brake	90	124346X	Nut Self-Thd Wshd 1/4
29	71673	Cap, Parking Brake	95	170201	Control Asm Bypass Hydro
30	169592	Bracket, Transmission	96	STD624003	Spring, Retainer 1"
32	74760512	Bolt Hex 5/16-18 UNC x 3/4	116	72140608	Bolt Rdhd Sq Neck 3/8-16 x 1
34	175578	Shaft, Foot Pedal	120	73900600	Nut Lock Flg 3/8-16
35	120183X	Bearing, Nylon	150	175456	Spacer Retainer
36	19211616	Washer	151	19133210	Washer 13/32 x 2 x 10
37	1572H	Pin, Roll	156	166002	Washer 5/16 x 1.0 x 1.25
38	179114	Pulley, Composite	158	165589	Bracket Shift Mount
39	74760648	Bolt	159	183900	Hub Tapered Flange Shift
41	175556	Keeper, Belt, Idler	161	72140406	Bolt Rdhd Sqnk 1/4-20 x 3/4 Gr. 5
47	127783	Pulley, Idler, V-Belt	162	73680400	Nut Crownlock 1/4-20 Unc
48	154407	Bellcrank Clutch Grnd Drustl	163	74780416	Bolt Hex Fin 1/4-20 x 1
49	123205X	Retainer, Belt	164	19091010	Washer 5/8 x .281 x 10 Ga.
50	72110612	Bolt Carr. Sh 3/8-16 x 1-1/2 Gr. 5	165	165623	Bracket Pivot Lever
51	STD541437	Nut	166	166880	Screw 5/16 x 1.0 x .125
52	STD541431	Nut Crownlock 5/16-18	168	165492	Bolt Shoulder 5/16-18 x .561
53	105710X	Link, Clutch	169	165580	Plate Fastener Cross Shaft
55	105709X	Spring, Return, Clutch	197	169613	Nyliner Snap-In
56	17060620	Screw 3/8-16 x 1-1/4	198	169593	Washer Nyliner
57	140294	V-Belt, Drive	199	169612	Bolt Shoulder 5/16-18 Unc
59	169691	Keeper, Belt, Center	200	72140508	Bolt RdHd Sqnk 5/16-18 unc x 1
61	17120614	Screw 3/8-16 x .875	202	72110614	Bolt Carr. Sh 3/8-16 x 1-3/4 Gr. 5
62	8883R	Cover, Pedal	212	145212	Nut Hex Flange Lock
63	175410	Pulley, Engine	250	17060612	Screw 3/8-16 x 3/4
64	71170764	Bolt Hex 7/16 x 4 Gr. 5			
65	10040700	Washer			
66	154778	Keeper, Belt Engine Hydro			

NOTE: All component dimensions given in U.S. inches
1 inch = 25.4 mm

TRACTOR - - MODEL NUMBER 917.273160

STEERING ASSEMBLY

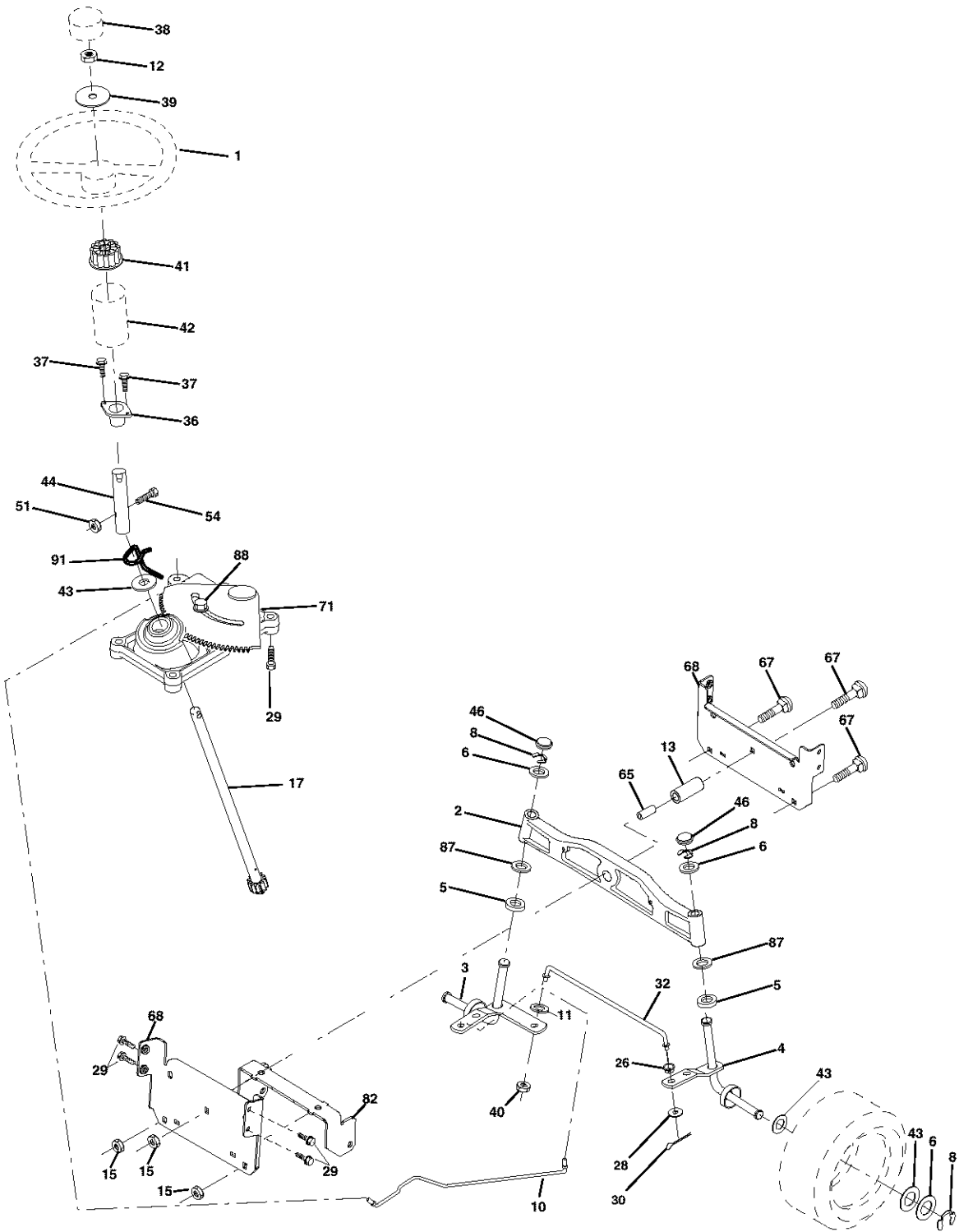

TRACTOR - - MODEL NUMBER 917.273160
STEERING ASSEMBLY

KEY NO.	PART NO.	DESCRIPTION
1	184704X428	Steering Wheel
2	172393	Axle Assembly Cast Iron
3	169840	Spindle Assembly, L.H.
4	169839	Spindle Assembly, R.H.
5	6266H	Bearing, Race, Thrust, Hardened
6	121748X	Washer 25/32 x 1-5/8 x 16 Gauge
8	12000029	Ring, Klip
10	175121	Draglink
11	STD551137	Washer, Lock
12	73940800	Nut Hex Jam Toplock 1/2-20 Unf
13	136518	Spacer Bearing Axle Front
15	145212	Nut, Hex Flange Lock
17	180641	Shaft Assembly, Steering
26	126847X	Bushing, Link, Drag
28	19131416	Washer 13/32 x 7/8 x 16 Gauge
29	17060612	Screw 3/8-16 x 3/4
30	STD561210	Pin Cotter
32	130465	Rod, Tie
36	155099	Bushing, Steering
37	152927	Screw
38	159946X428	Insert, Steering Wheel
39	19182411	Washer 9/16 Id x 1-1/2 OD 11 G. Zin
40	159945	Nut Lock Center 3/8-24 Unf
41	159945	Adaptor, Steering Wheel
42	145054X428	Boot, Steering Shaft
43	121749X	Washer 25/32 x 1-1/4 x 16 Gauge
44	180640	Extension Shaft Steering LR.LT
46	184946X505	Cap, Spindle
51	73540400	Nut Crownlock 1/4-28
54	71130420	Bolt Hex 1/4-28 Unf x 1-1/4 Gr. 8
65	160367	Spacer Brace Axle
67	72140618	Bolt RDHD Sqnk 3/8-16 x 2-1/4
68	169827	Axle, Brace
71	175146	Steering Asm.
82	169835	Bracket Susp. Chassis Front
87	173966	Washer Flat .781 x 1-1/2 x .14
88	175118	Bolt Shoulder 7/16-20 Unc
91	175553	Clip Steering

NOTE: All component dimensions given in U.S. inches
1 inch = 25.4 mm

TRACTOR - - MODEL NUMBER 917.273160

ENGINE

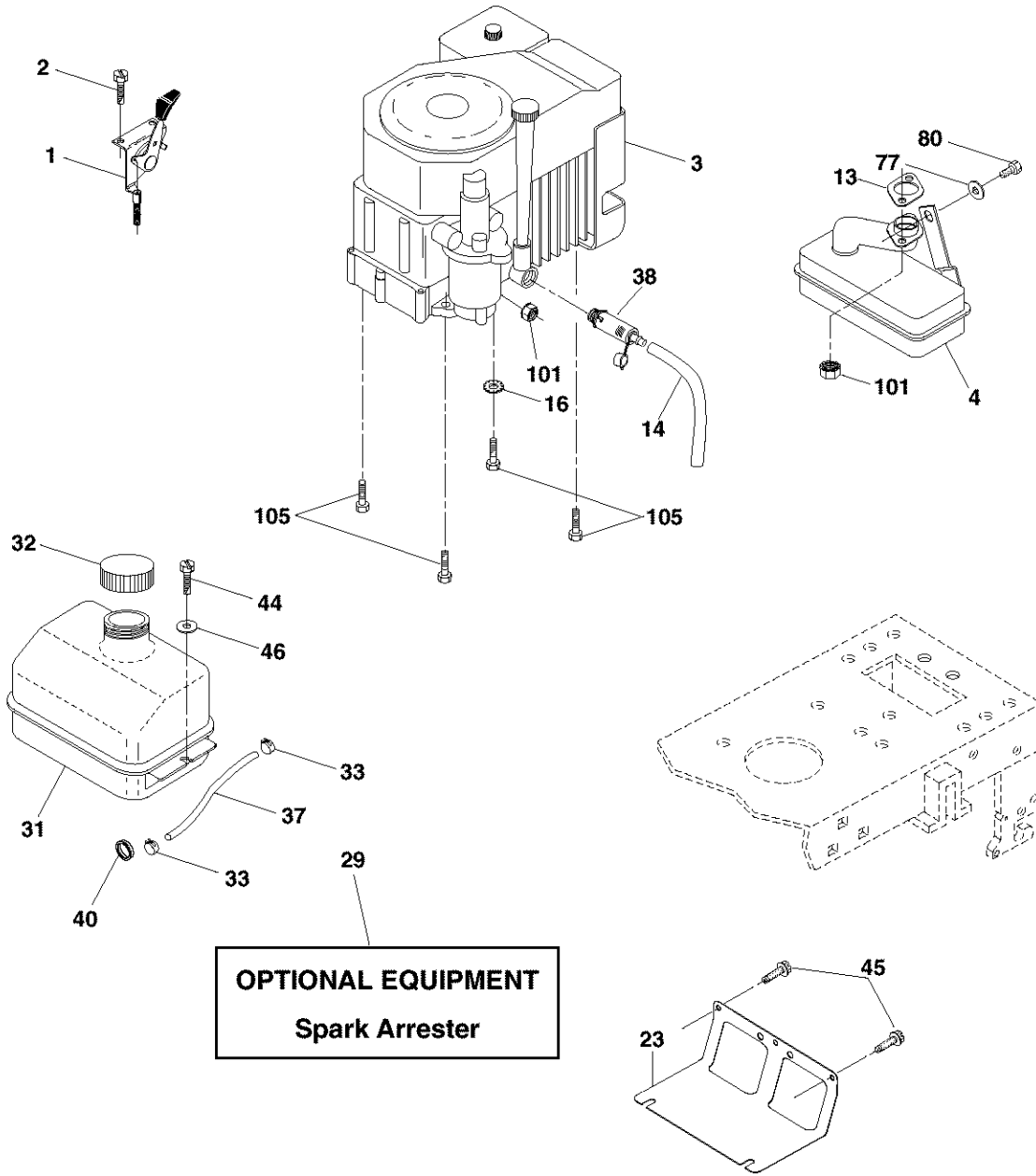

OPTIONAL EQUIPMENT
Spark Arrester

KEY PART NO.	NO.	DESCRIPTION
1	170548X505	Control, Throttle
2	17720408	Screw, Hex Head, Thread Cutting 1/4-20 x 1/2
3	-----	Engine, (See Breakdown) Kohler Model CV492-27506
4	174667	Muffler
13	12-001-03	Gasket
14	148456	Tube Drain Oil Easy
16	STD551237	Washer
23	169837	Shield Brn/Dbr Guard
29	137180	Arrester, Spark
31	184900	Tank, Fuel
32	140527	Cap Assembly, Fuel Sears, Vented
33	123487X	Clamp, Hose

KEY PART NO.	NO.	DESCRIPTION
37	137040	Line, Fuel
38	181654	Plug Drain Oil Easy
40	124028X	Bushing, Snap, Fuel Line
44	17670412	Screw, Hex Washer Head, Thd., Roll. 1/4-20 x 3/4
45	17000612	Screw Hxwsh Thdr 3/8-16 x 3/4
46	19091416	Washer 9/32 x 7/8 x 16 Ga
77	19101216	Washer 5/16 x 3/4 x 16 Ga.
80	74760508	Bolt Hex Hd 5/16-18 Unc x 1/2
101	M73030800	Nut Flange M8-1.25 Non-Lk Zinc
105	17120616	Screw 3/8-16 x 1

NOTE: All component dimensions given in U.S. inches
1 inch = 25.4 mm

TRACTOR - - MODEL NUMBER 917.273160
SEAT ASSEMBLY

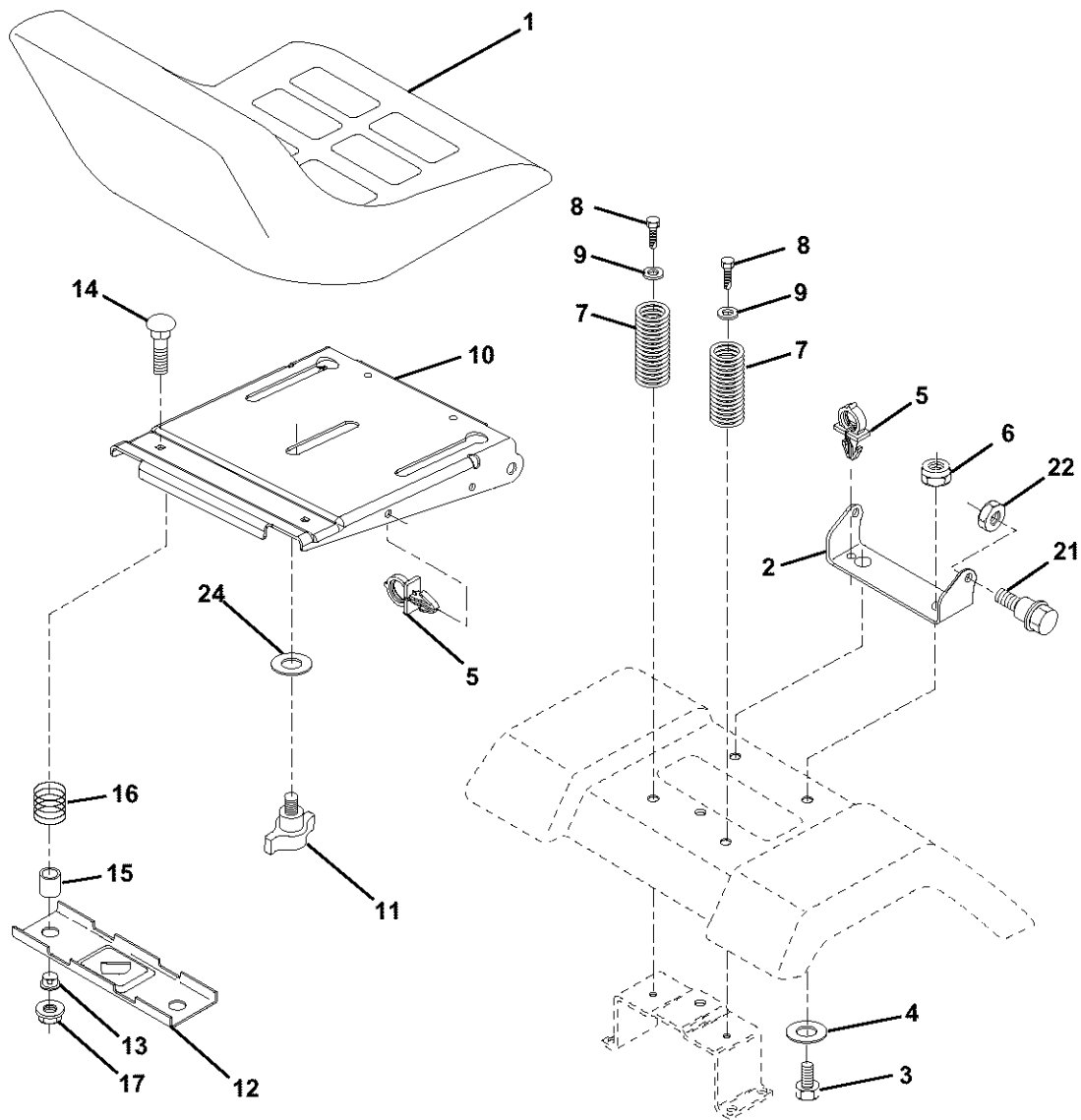

KEY PART NO.	NO.	DESCRIPTION
1	180597	Seat
2	180166	Bracket Pnt Pivot Seat (blk)
3	71110616	Bolt Fin Hex 3/8-16unc X 1
4	19131610	Washer 13/32 X 3/4 X 10 Ga
5	145006	Clip Push In Hinged
6	STD541437	Nut Hex Lock w/Ins 3/8-16 Unc
7	124181X	Spring Seat Cprsn 2 250 Blk Zi
8	17000616	Screw 3/8-16 X 1
9	19131614	Washer 13/32 X 1 X 14 Ga
10	180186	Pan Pnt Seat (blk)
11	166369	Knob Seat Adj Wingnut

KEY PART NO.	NO.	DESCRIPTION
12	121246X	Bracket Pnt Mounting Switch
13	121248X	Bushing Snap Blk Nyl 50 Id
14	72050412	Bolt Rdhd Sht Nk 1/4-20x1-1/2
15	134300	Spacer Split 28 X 96 Zinc
16	121250X	Spring Cprsn 1 27 Blk Pnt
17	123976X	Nut Lock 1/4 Lge Flg Gr 5 Zinc
21	171852	Bolt Shoulder 5/16-18 Unc-2A
22	STD541431	Nut Hex Lock w/Ins 5/16-18
24	19171912	Washer 17/32 X 1-3/16 X12Ga.

NOTE: All component dimensions given in U.S. inches
 1 inch = 25.4 mm

TRACTOR - - MODEL NUMBER 917.273160

DECALS

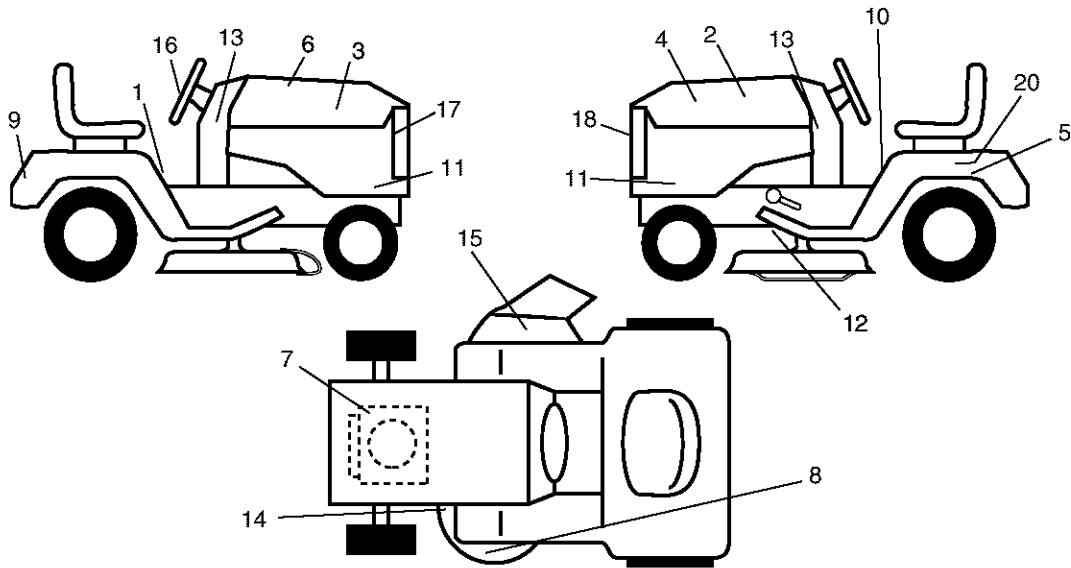

KEY PART NO. NO.

KEY PART NO.	NO.	DESCRIPTION
1	156811	Decal, Oper. Instr.
2	187049	Decal, Replacement
3	186280	Decal, Hood, R.H.
4	186281	Decal, Hood, L.H.
5	138047	Decal, Battery
6	133644	Decal, Customer Maintenance
7	177374	Decal, HP Engine
8	172331	Decal, Mower Srs
9	186282	Decal, Fender, Craftsman
10	156439	Decal, Fender Danger
11	186283	Decal, Panel Side
12	146046	Decal, V-Belt Drive Schematic
13	177350	Decal, Dash Panel

KEY PART NO. NO.

KEY PART NO.	NO.	DESCRIPTION
14	160396	Decal, V-Belt Schematic
15	179128	Decal, Deck B 42"
16	164065	Decal, Strong Whl.
17	184842	Decal, Grille RH
18	184843	Decal, Grille LH
20	149516	Decal Battery Dngr/Psn Eng
--	138311	Decal, Lift Handle
--	169210	Decal, By pass
--	165800X428	Pad Footrest LH STLT
--	165799X428	Pad Footrest RH STLT
--	185006	Owner's Manual, English
--	185007	Owner's Manual, Spanish

WHEELS & TIRES

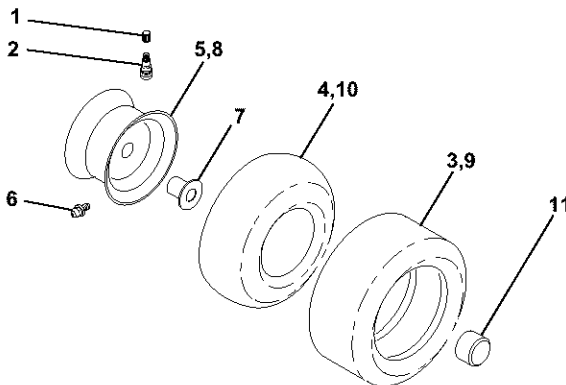

KEY PART NO. NO.

KEY PART NO.	NO.	DESCRIPTION
1	59192	Cap Value Tire
2	65139	Stem Value
3	106222X	Tire F Ts 15 X 6 0 - 6 Service
4	59904	Tube Inner Front #35060
5	106732X624	Rim Asm 6"front White Service
6	278H	Fitting Grease
7	9040H	Bearing Flange
8	106108X624	Rim Asm 8"rear White Service
9	122082X	Tire R Ts 20 X 10-8 Service
10	7152J	Tube Rear 9 5 X 8 Service
11	104757X428	Cap Axle Blk 1 50 X 1 00
--	144334	Sealant, Tire (10 oz. tube)

NOTE: All component dimensions given in U.S. inches
1 inch = 25.4 mm

TRACTOR - - MODEL NUMBER 917.273160

LIFT ASSEMBLY

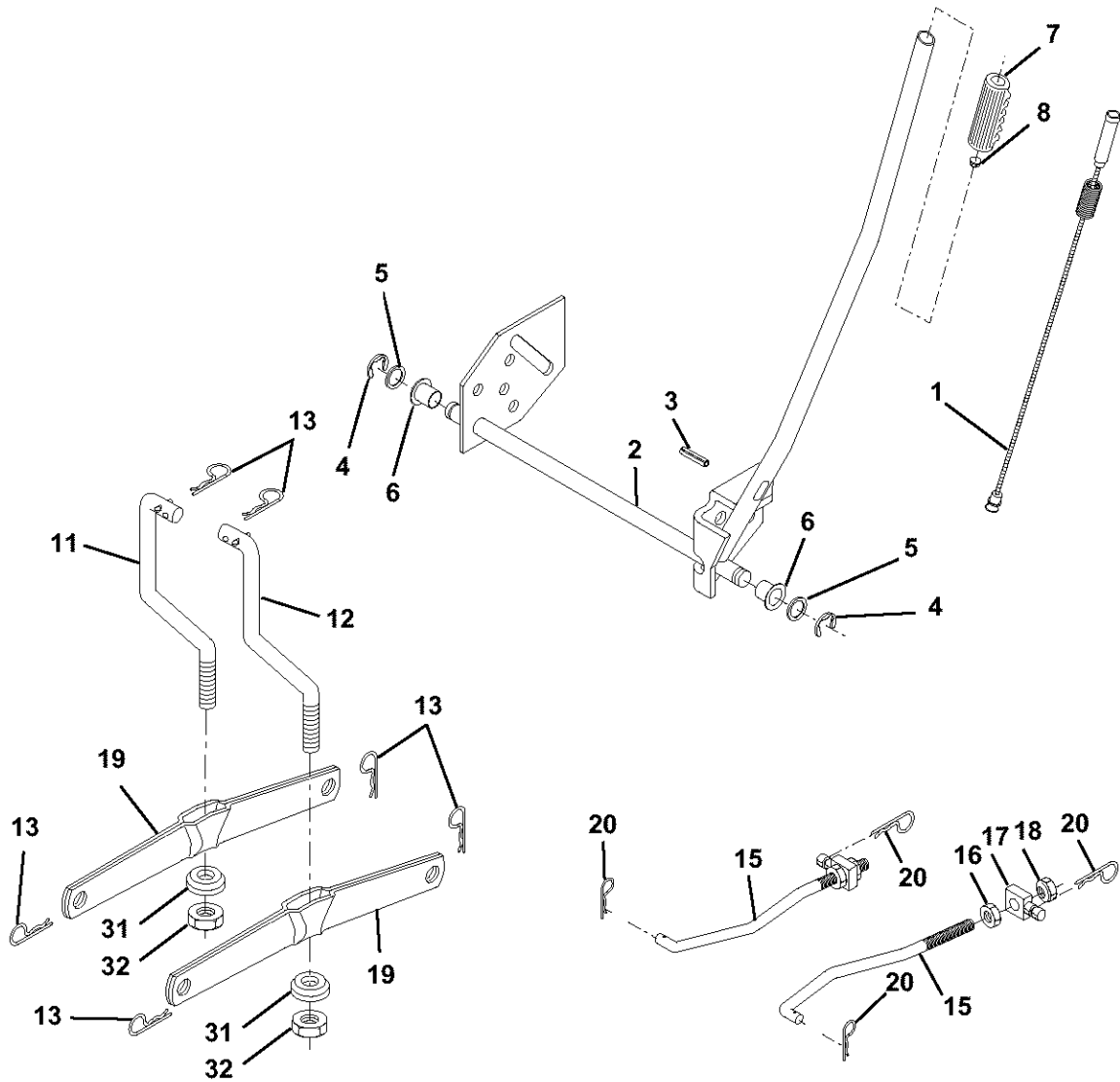

KEY PART NO.	PART NO.	DESCRIPTION
1	159460	Washer Asm Inner Spring W/ Plunger
2	159471	Shaft Asm. Lift
3	105767X	Pin Groove
4	12000002	E Ring #5133-62
5	19211621	Washer 21/32 x 1 x 21 Ga.
6	120183X	Bearing Nylon
7	125631X	Grip Handle Fluted
8	122365X	Button Plunger Read
11	139865	Link Asm Lift L.H.
12	139866	Link Asm Lift R.H.

KEY PART NO.	PART NO.	DESCRIPTION
13	STD624008	Retainer Spring
15	173288	Link Front
16	73350800	Nut Jam Hex 1/2-13 Unc
17	175689	Trunnion Blk Zinc
18	73800800	Nut Lock w/Wsh 1/2-13 Unc
19	139868	Arm Suspension Mower
20	163552	Retainer Spring
31	169865	Bearing, Pvt. Lift
32	73540600	Nut Crownlock 3/8-24

NOTE: All component dimensions given in U.S. inches
1 inch = 25.4 mm

TRACTOR - - MODEL NUMBER 917.273160

MOWER DECK

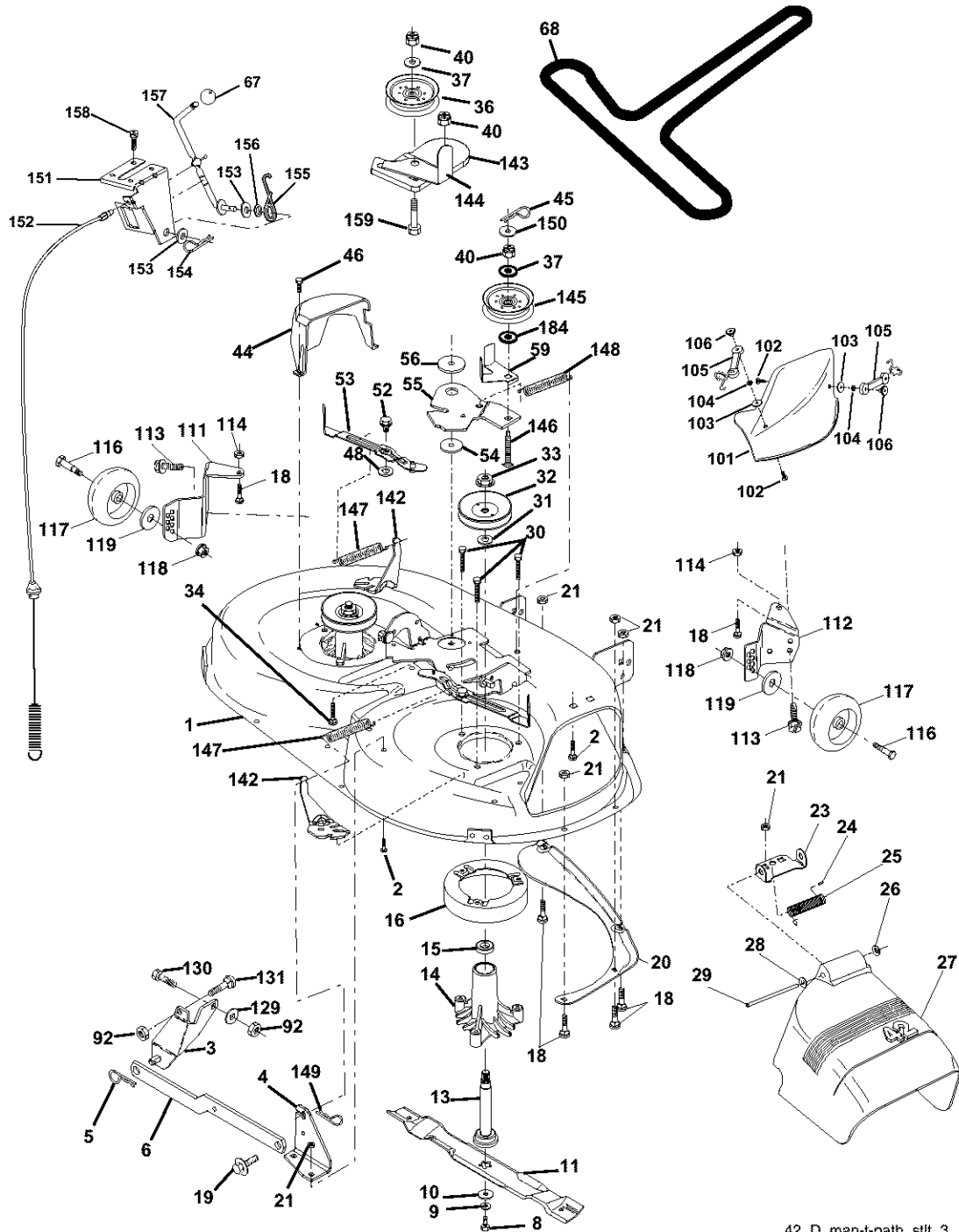

42_D_man-t-path_slit_3.

TRACTOR - - MODEL NUMBER 917.273160

MOWER DECK

KEY NO.	PART NO.	DESCRIPTION	KEY NO.	PART NO.	DESCRIPTION
1	165892	Mower Deck Assembly, 42"	67	184939	Knob Custom Oval
2	STD533107	Bolt	68	144959	V-Belt
3	138017	Bracket Assembly, Sway Bar, Front	92	STD541437	Nut
4	165460	Bracket Sway Bar 38/42" Deck	101	136420	Mulcher Cover
5	STD624008	Retainer Spring	102	71081010	Screw
6	178024	Bar Sway Deck	103	19061216	Washer #10
8	850857	Bolt, Hex 3/8-24 x 1.25 Gr. 8	104	STD551110	Washer, Lock
9	STD551137	Washer, Lock	105	160793	Latch Assembly, Bagger
10	140296	Washer, Hardened (The following blades are available)	106	2029J	Nut, Weld
11	134149	Blade, 42" Mulching Std (For mulching mowers only)	111	179292	Bracket Gauge Wheel Lh
--	139775	Blade, 42" Mulching Premium (For better wear when mulching)	112	179293	Bracket Gauge Wheel Rh
--	138971	Blade, 42" Hi-Lift (For bagging or discharging)	113	17060510	Screw 5/16-18 Unc
13	137645	Shaft Assembly, Mandrel, Vented	114	73510500	Nut Keps 5/16-18 Unc
14	128774	Housing, Mandrel, Vented	116	4898H	Bolt Shoulder
15	110485X	Bearing, Ball, Mandrel	117	165746	Wheel Gauge Std
16	174493	Stripper, Vented Mower Deck	118	73930600	Nut Centerlock 3/8-16 Unc
18	72140505	Bolt, Carriage 5/16-18 x 5/8	119	19121414	Washer 3/8 x 7/8 x 4 Ga.
19	132827	Bolt, Shoulder	129	19131312	Washer 13/32 x 13/16 x 12Ga.
20	159770	Baffle, Vortex	130	STD523710	Bolt, Fin Hex 3/8-16 Unc x 1 Gr. 5
21	STD541431	Nut Crownlock 5/16-18 Unc	131	STD533710	Bolt, Rdhd Sqnk 3/8-16Unc x1
23	177563	Bracket, Deflector	142	165890	Arm Spring Brake Mower
24	105304X	Cap, Sleeve	143	157109	Bracket Arm Idler 42"
25	123713X	Spring, Torsion, Deflector	144	158634	Keeper Belt 42" Clutch Cable
26	110452X	Nut, Push	145	165888	Pulley Idler Flat
27	130968X428	Shield, Deflector	146	171977	Bolt Carriage Idler
28	19111016	Washer 11/32 x 5/8 x 16 Ga.	147	131335	Spring Extension
29	131491	Rod, Hinge	148	169022	Spring Return Idler
30	173984	Screw Thdrol Washer Head	149	165898	Retainer Spring Yellow Zinc
31	129963	Washer, Spacer	150	19091216	Washer 9/32 x 3/4 x 16 Ga.
32	153535	Pulley, Mandrel	151	169670	Bracket Clutch
33	178342	Nut, Toplock, Flanged	152	169676	Cable Clutch 42 In
34	STD533717	Bolt	153	169674	Washer Flat 3/8" Type B
36	131494	Pulley, Idler, Flat	154	169675	Spring Retainer
37	STD551037	Washer 13/32 x 13/16 x 16Ga.	155	169671	Spring Retention Lever
40	STD541437	Nut Crownlock 3/8-16 Unc	156	169672	Spacer
44	140088	Guard, Mandrel, L.H.	157	169669	Rod Clutch
45	STD624003	Retainer	158	17720408	Screw Hex Thd Cut 1/4-20 x 1/2
46	137729	Screw, Thd. Roll 1/4-20 x 5/8	159	72140614	Bolt Rdhd Sqn 3/8-16 Unc x 3/4
48	133944	Washer, Hardened	184	19131410	Washer 13/13 x7/8 x 10 Ga.
52	139888	Bolt, Shoulder 5/16-18 Unc	--	130794	Mandrel Assembly (Includes Housing, Shaft and Shaft Hardware Only - Pulley Not Included)
53	184907	Arm Assembly, Pad, Brake	--	169583	Replacement Mower, Complete (Std. Deck-Order separately mulcher cover and gauge wheel components key nos. 101 - 106 and 116 - 119).
54	178515	Washer, Hardened			
55	155046	Arm, Idler			
56	165723	Spacer, Retainer			
59	141043	Guard, TUV Idler			

NOTE: All component dimensions given in U.S. inches
1 inch = 25.4 mm

TRACTOR - - MODEL NUMBER 917.273160
 HYDRO GEAR TRANSAXLE - - MODEL NUMBER 314-0510

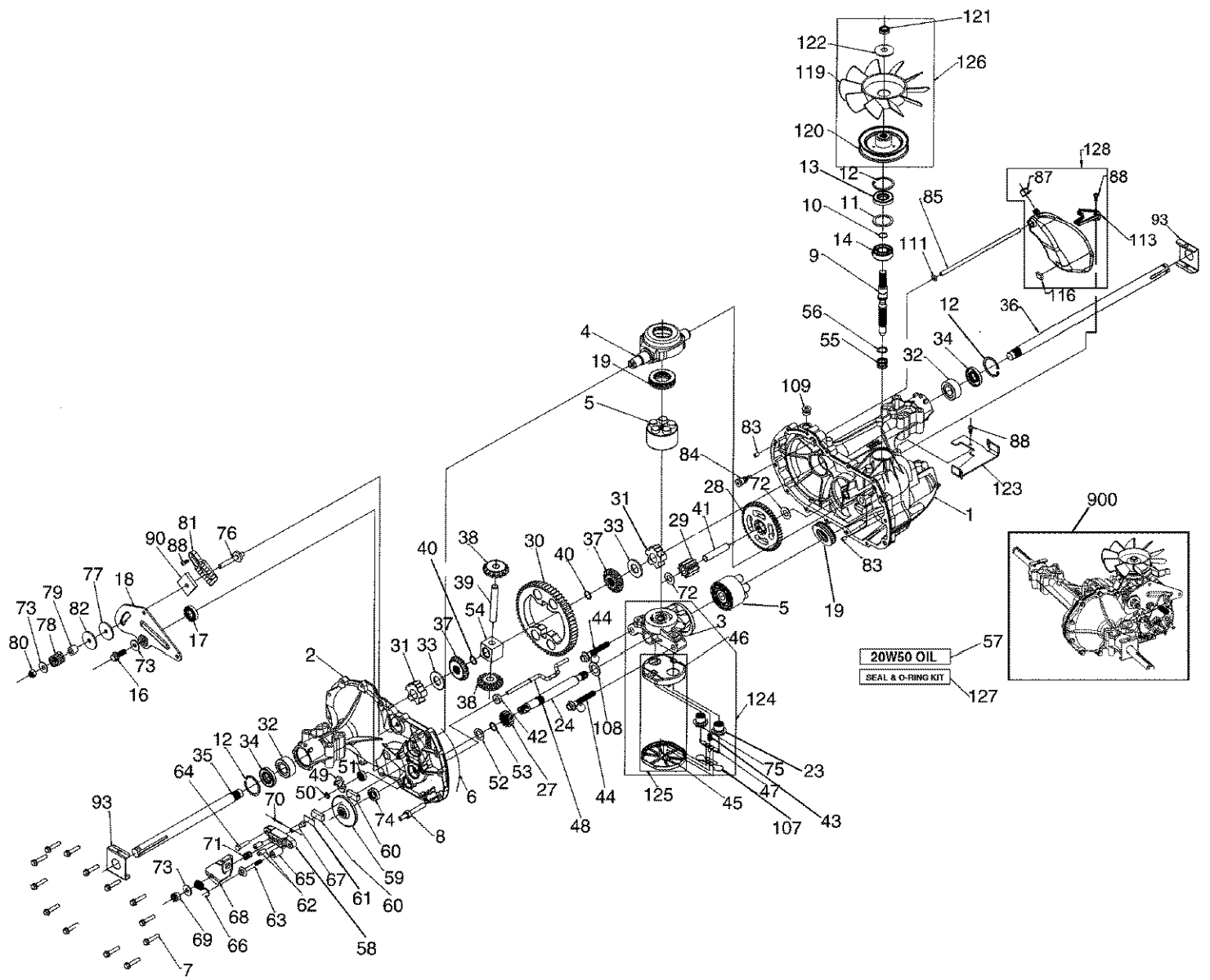

TRACTOR - - MODEL NUMBER 917.273160
HYDRO GEAR TRANSAXLE - - MODEL NUMBER 314-0510

KEY NO.	PART NO.	DESCRIPTION	KEY NO.	PART NO.	DESCRIPTION
1	170351	Main Housing, Assembly	59	170408	Rotor, Brake
2	170352	Side Housing, Assembly	60	142883	Brake Puck
3	170353	Center Section, Assembly	61	142882	Puck Plate
4	170354	Swashplate, Trunion Machined	62	142887	Brake Actuating Pin
5	169898	Block - Assembly	63	170410	Hfhcs 1/4-20x2 W/ Patch,SpecialFlange
6	170355	Sealant 10.5 Oz	64	142892	Bolt, 1/4-20 X 1 W/Patch
7	170356	Hex Flange Screw 1/4-20 x 1.25	65	170411	Spacer
8	170357	Stud, 5/16-24 Hex Double End	66	170412	Spring, Brake Arm Bias
9	170358	Shaft, Input	67	170413	Sq. Hd. Bolt 5/16-24-Ribbed
10	170359	Ring - Retaining	68	170414	Arm, Brake
11	170360	Spacer	69	170415	Slotted Hex Nut 5/16-24
12	169870	Ring - Retaining	70	170416	Cotter Pin 3/32 X 3/4
13	170361	Seal, Lip .67 X 1.58 X .276	71	170417	Compression Spring Brake Anti-Drag
14	169869	Ball Brg 17mm Id X 40mm Od X 12mm	72	170418	Washer, Ht .5 I.D. X 1 O.D. x .032
16	170362	Hex Flange Head Screw 5/ 16-24X0.75	73	142884	Flat - Washer 11/32 I.D. X 7/8 O.D
17	170363	Lip Seal 18 X 32 X 7	74	170419	Oil Seal .625 X 1.0 X .25
18	170364	Arm, Control	75	170420	Check Plug Assembly, .027, Washer
19	150771	Bearing, 30x52x13 Thrust	76	170421	Stud, 5/16-24 Friction Pack
23	170365	Check Plug Assembly, Washer	77	170422	Puck, .330 X 1.50 X .0975
24	170366	Shaft, Motor	78	142969	Spring, Helical Comp
27	170367	Gear - Pinion, 13t	79	142980	Spacer
28	170368	10t/48t Gear	80	150778	Hex Lock Nut 5/16-24 Unf (Nylon Insert)
29	170369	Gear, 10t Jackshaft	81	170423	Wedge, Friction Pack
30	170370	60t Bull Gear	82	170424	Clip, Washer .316x1.50x.1046 (Plated)
31	170371	Sleeve Bearing .75 X 1.575 X .625	83	161168	Pin, Standard Headless
32	170389	SleeveBearing(Outboard) .75x1.750x.625	84	170425	Fitting, 5/16 Sae 5/32 Tube
33	142991	Washer, 3/4 Id X 1-1/2 Od X .13 Thk	85	170426	Hose, Expansion Tank
34	170390	Lip Seal Axle Seal	87	142917	Cap - Poppet Valve
35	170391	Shaft, Axle .75 X 11.39 (Key, R.H.)	88	170429	Bolt, Self Tapping 10-32X1/2
36	170392	Shaft, Axle .75 X 16.99 (Key, L.H.)	90	170430	Puck, Inner Wedge
37	150792	Miter Gear (Splined)	93	170431	Spring Clip - Housing Thrust
38	150793	Miter Gear 15t (0.5 Id)	107	170432	Deflector
39	150809	Shaft	108	170433	Washer, Motor Shaft .71idx1.15odx.030thk
40	170393	Ring, Spiral Retaining	109	170434	Plug, Sae #6
41	170394	Pin, Jackshaft	111	170435	O-Ring .07 X .301 I.D.
42	170395	Magnet, Ring	113	170437	Bracket, Support Expansion Tank
43	170396	Spring, Bypass	116	170438	Silicon Sponge
44	150797	Hydro Mtg Screw 3/8-24 X 2.5 Long	119	170439	Fan, 7 In.
45	170397	Filter	120	170440	Pulley
46	170398	Base, Filter	121	170441	Hex Lock Nut 1/2-20 (Nylon Insert)
47	170399	Actuator, Bypass	122	170442	Washer, Belleville
48	170400	Rod, Bypass Actuator	123	170443	Belt Keeper
49	170401	Arm, Bypass	124	170444	Center Section-Filter-Bypass Assembly
50	170402	Retaining Ring .250 External	125	170445	Filter Assembly
51	170403	Seal, Lip .741 X .250 X .250 Tc	126	170446	Fan - Pulley Service Assembly
52	170404	Flat Washer, 5/8 Id X 1.0 Od X .05 Thk	127	170447	Seal - O-Ring Kit
53	170405	Retaining Ring	128	173165	Kit, Expansion Tank
54	170406	Bearing, Center Block	900	166768	Transaxle Complete
55	142977	Spring - Helical Compression			
56	142978	Washer			
57	150798	20w-50 Oil			
58	170407	Brake Yoke			

NOTE: All component dimensions given in U.S.
inches 1 inch = 25.4 mm

TRACTOR - - MODEL NUMBER 917.273160
KOHLER ENGINE-MODEL NUMBER CV492, TYPE NUMBER 27506

CYLINDER HEAD, VALVE AND BREATHER
CYLINDRE DIRIGE SOUPE ET RENIFLARD

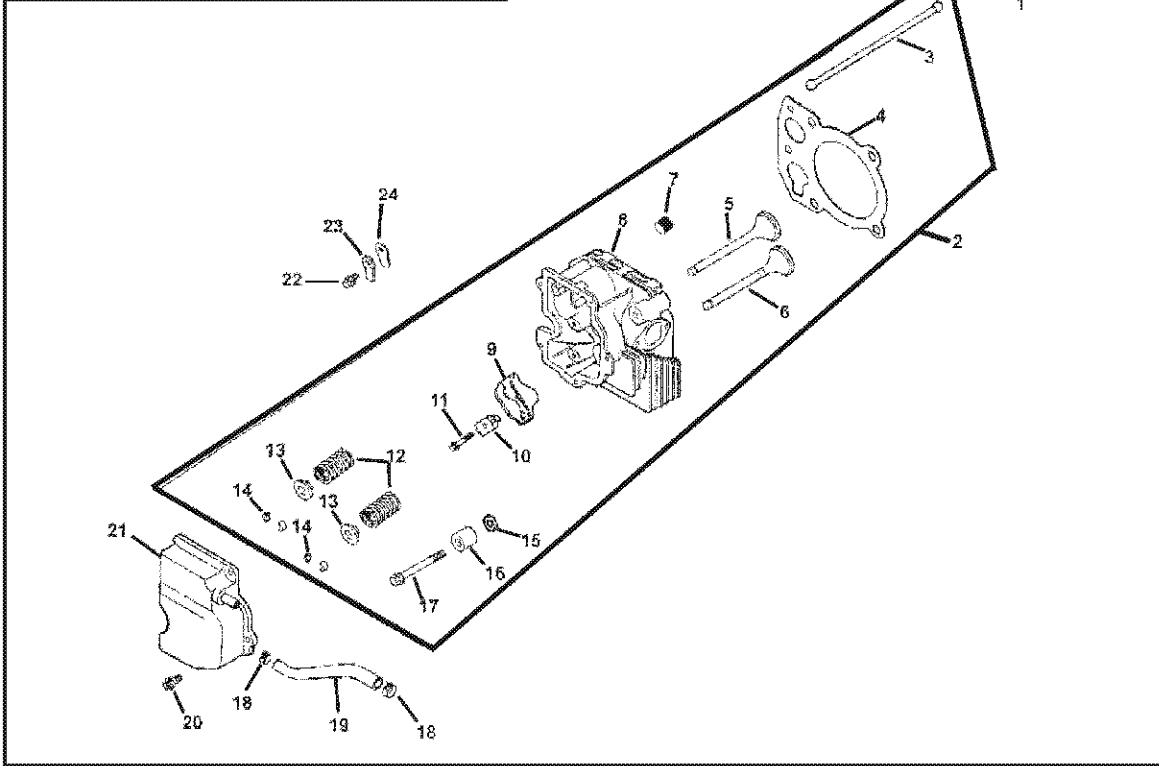

CRANKCASE | CARTER-MOTEUR

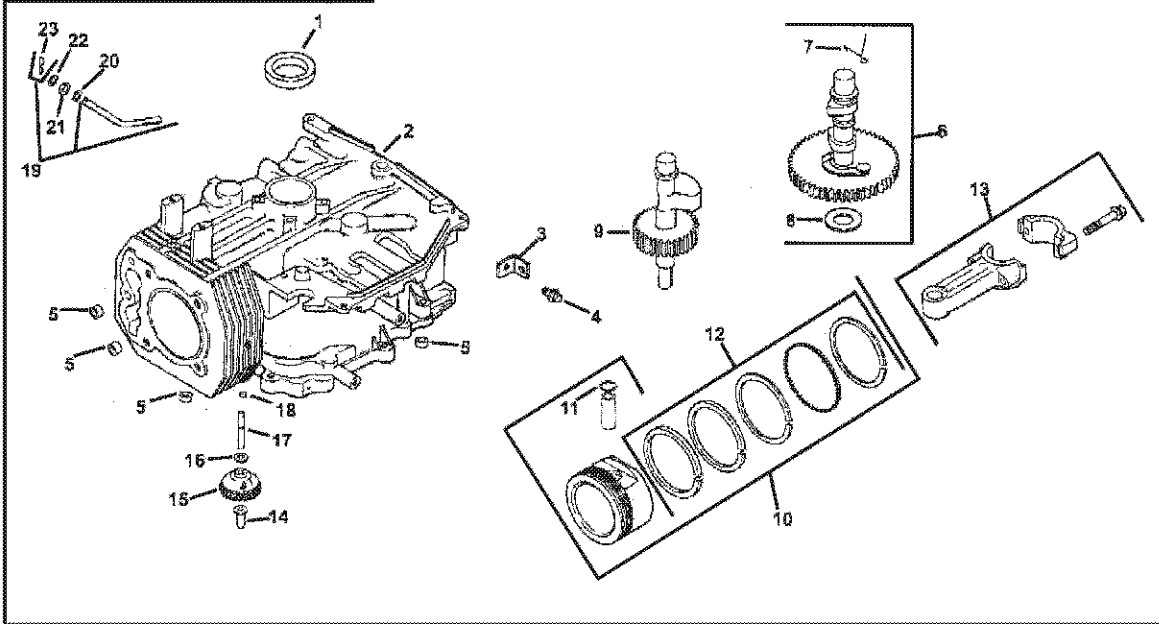

**TRACTOR - - MODEL NUMBER 917.273160
 KOHLER ENGINE-MODEL NUMBER CV492, TYPE NUMBER 27506**

CYLINDER HEAD/VALVE/BREATHER

KEY NO.	PART NO.	DESCRIPTION
1	25-351-01-S	Lifter, valve (2)
2	12-755-94-S	Kit, cylinder head (Includes 3-17, Gaskets 12 041 01-S (Qty. 2), 12 041 02-S, & 12 041 03-S)
3	12-411-03-S	Rod, push (2)
4	12-041-10-S	Gasket, cylinder head
5	12-017-01-S	Valve, intake (Std.)
	12-017-02-S	Valve, intake (.25)
6	12-016-01-S	Valve, exhaust (Std.)
	12-016-02-S	Valve, exhaust (.25)
7	25-139-60-S	Plug, allen hd. pipe 1/8"
8	12-318-36-S	Cylinder Head
9	25-186-01-S	Arm, rocker (2)
10	12-599-03-S	Pivot, rocker arm (2)
11	M-640034-S	Screw, hex. flange M6x1.0x34 (2)
12	12-089-01-S	Spring, valve (2)
13	12-173-01-S	Cap, valve spring (2)
14	12-755-03-S	Kit, retainer (2)
15	12-468-05-S	Washer, plain 13/32"
16	12-112-13-S	Spacer, head bolt exhaust port
17	12-086-15-S	Screw, hex. flange M10x1.5x81 (5)
18	25-237-14-S	Clamp, hose (2)
19	12-326-03-S	Hose, breather
20	M-645020-S	Screw, hex. flange M6x1.0x20 (5)
21	12-096-07-S	Cover, valve w/nipple
22	M-545010-S	Screw, hex. flange M5x0.8x10
23	12-018-01-S	Retainer, breather reed
24	12-402-02-S	Reed, breather

CRANKCASE

KEY NO.	PART NO.	DESCRIPTION
1	12-032-03-S	Seal, crankshaft
2		Block, cylinder (Use Short Block 12 522 49)
3	12-445-02-S	Strap, lifting
4	M-839025-S	Screw, hex. flange M8x1.25x25
5	24-380-13-S	Dowel, locating (4)
6	12-755-49-S	Kit, camshaft (Includes 7,8)
7	12-089-31-S	Spring, actuating
8	12-422-08-S	Shim, camshaft (A.R.) blue
	12-422-09-S	Shim, camshaft (A.R.) red
	12-422-10-S	Shim, camshaft (A.R.) yel low
	12-422-11-S	Shim, camshaft (A.R.) green
	12-422-12-S	Shim, camshaft (A.R.) gray
	12-422-13-S	Shim, camshaft (A.R.) black
	12-422-07-S	Shim, camshaft (A.R.) white
9	12-144-28-S	Shaft, balance
10	12-874-07-S	Piston w/Ring Set (Std.) (Includes 11,12)
	12-874-11-S	Piston w/Ring Set (.08)
	12-874-08-S	Piston w/Ring Set (.25)
	12-874-09-S	Piston w/Ring Set (.50)
11	12 018 02-S	Retainer, piston pin (2)
12	12-108-07-S	Ring Set (Std.)
	12-108-08-S	Ring Set (.25)
	12-108-09-S	Ring Set (.50)
13	12-067-11-S	Connecting Rod (Std.)
	12-067-06-S	Connecting Rod (.25)
14	12-380-01-S	Pin, governor regulating
15	12-043-05-S	Gear, governor
16	M-631005-S	Washer, plain 6 mm
17	12-144-02-S	Shaft, governor gear
18	52-139-09-S	Plug, cup
19	12-755-64-S	Kit, gov. cross shaft w/clip (Includes 23)
20	X-25-102-S	Washer, plain 1/4"
21	12-032-01-S	Seal, governor cross shaft
22	M-631015-S	Washer, plain 6 mm
23	12-154-05-S	Clip, hitch pin

NOTE: All component dimensions given in U.S. inches 1 inch = 25.4 mm

**TRACTOR - - MODEL NUMBER 917.273160
 KOHLER ENGINE-MODEL NUMBER CV492, TYPE NUMBER 27506**

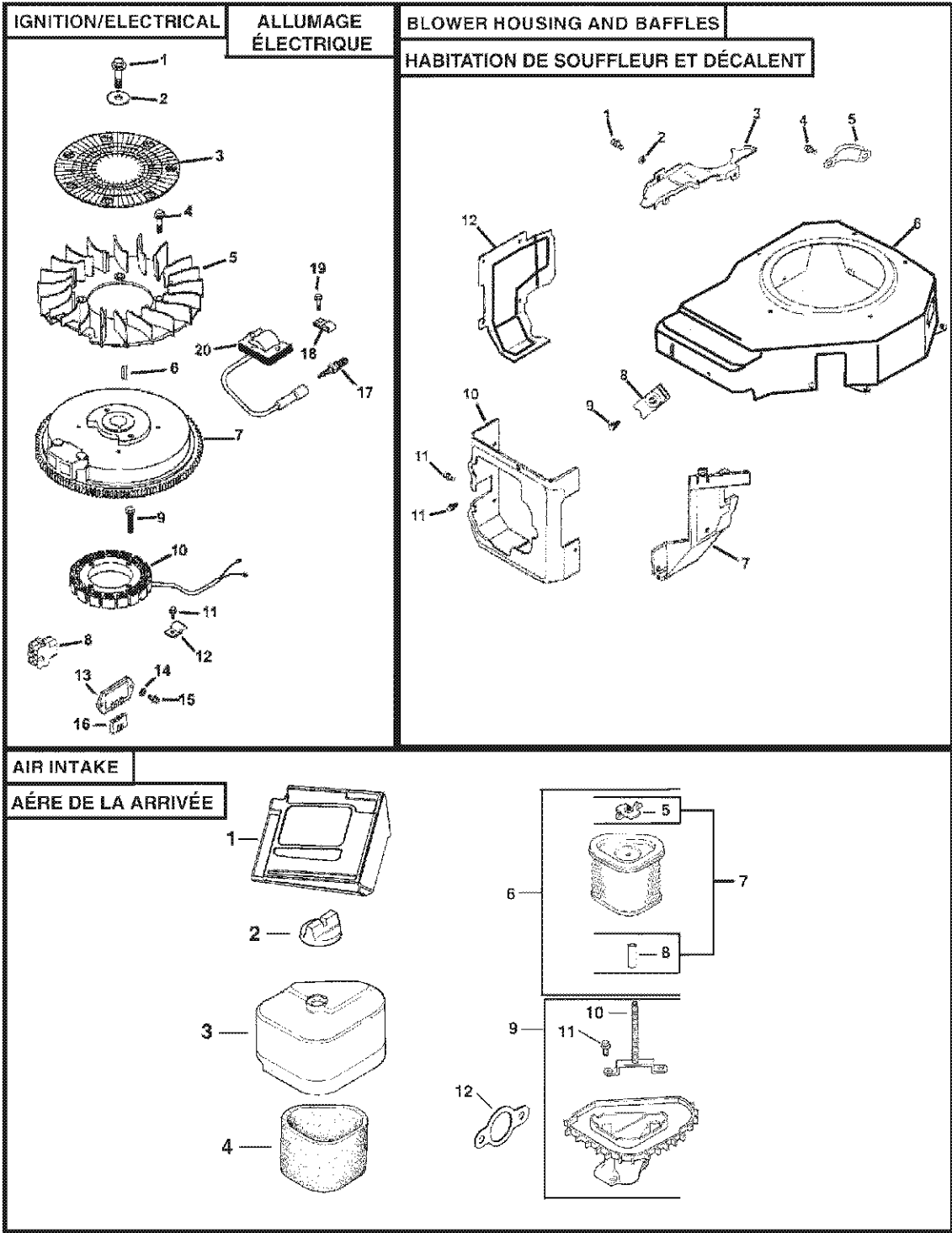

**TRACTOR - - MODEL NUMBER 917.273160
KOHLER ENGINE-MODEL NUMBER CV492, TYPE NUMBER 27506**

IGNITION/ELECTRICAL

KEY NO.	PART NO.	DESCRIPTION
1	12-086-14-S	Screw, hex. flange M10x1.5x46
2	12-468-03-S	Washer, plain 3/8"
3	24-162-03-S	Screen, grass
4	25-086-47-S	Bolt, shoulder M6x1.0x16 (4)
5	12-157-06-S	Fan
6	X-42-15-S	Key
7	12-025-15-S	Flywheel
8	12-155-09-S	Connector
9	M-548025-S	Screw, hex. cap M5x0.8x25 (2)
10	237878-S	Kit, stator
11	M-545020-S	Screw, hex. flange M5x0.8x20 (2)
12	12-154-06-S	Clip, cable (2)
13	41-403-09-S	Regulator, rectifier - 15 amp
14	X-22-11-S	Washer, lock 1/4"
15	M-639016-S	Screw, hex. flange M6x1.0x16 (2)
16	236602-S	Connector
17	12-132-02-S	Spark Plug
18	X-728-1-S	Clip, cable (2)
19	M-545010-S	Screw, hex. flange M5x0.8x10 (2)
20	12-584-04-S	Module, ignition

NOT ILLUSTRATED

12-176-44-S	Harness, wiring
24-518-12-S	Lead, black (6" - 12 gauge-insulated grip barrel eyelet terminals)
12-518-35-S	Lead, white (36" - 18 gauge - fully insulated push on tab and uninsulated socket terminals)
X-25-5-S	Washer, plain 5/16" (attach ground lead and this washer to lift strap screw)

BLOWER HOUSING & BAFFLES

KEY NO.	PART NO.	DESCRIPTION
1	M-545010-S	Screw, hex. flange M5x0.8x10 (6)
2	24-468-10-S	Washer, plain 1/4"
3	12-146-07-S	Plate, blower housing
4	M-550010-S	Screw, hex. flange M5x0.8x10
5	24-096-05-S	Cover, pinion
6	12-027-76-S	Housing, blower
7	12-063-18-S	Baffle, intake side
8	25-154-02-S	Clip, mounting (3)
9	12-086-37-S	Screw, captive washer M5x0.8x20 (3)
10	12-063-20-S	Baffle, cylinder head
11	M-645016-S	Screw, hex. flange M6x1.0x16 (2)
12	12-063-19-S	Baffle, cylinder

NOT ILLUSTRATED

M-541050-S	Nut, hex. flange M5x0.8
------------	-------------------------

AIR INTAKE/FILTRATION

KEY NO.	PART NO.	DESCRIPTION
1	12-281-01-S	Duct, air
2	25-341-03-S	Knob, air cleaner cover
3	12-096-24-S	Cover, air cleaner
4	12-083-12-S	Precleaner, element
5	12-100-08-S	Wing Nut
6	12-083-10-S	Kit, air cleaner element (Includes 5, 7, 8)
7	12-743-12-S	Filter, element (Includes 5, 8)
8	12-032-11-S	Seal 1-7/16"
9	12-094-07-S	Base, air cleaner (Includes 11, 12)
10	12-072-04-S	Stud, mounting plate M6x1.0x75
11	12-086-01-S	Screw, #10 Hi-Lo thread forming (2)
13	12-041-02-S	Gasket, air cleaner

NOT ILLUSTRATED

12-113-53-S	Decal, air cleaner
-------------	--------------------

NOTE: All component dimensions given in U.S. inches 1 inch = 25.4 mm

TRACTOR - - MODEL NUMBER 917.273160
KOHLER ENGINE-MODEL NUMBER CV492, TYPE NUMBER 27506

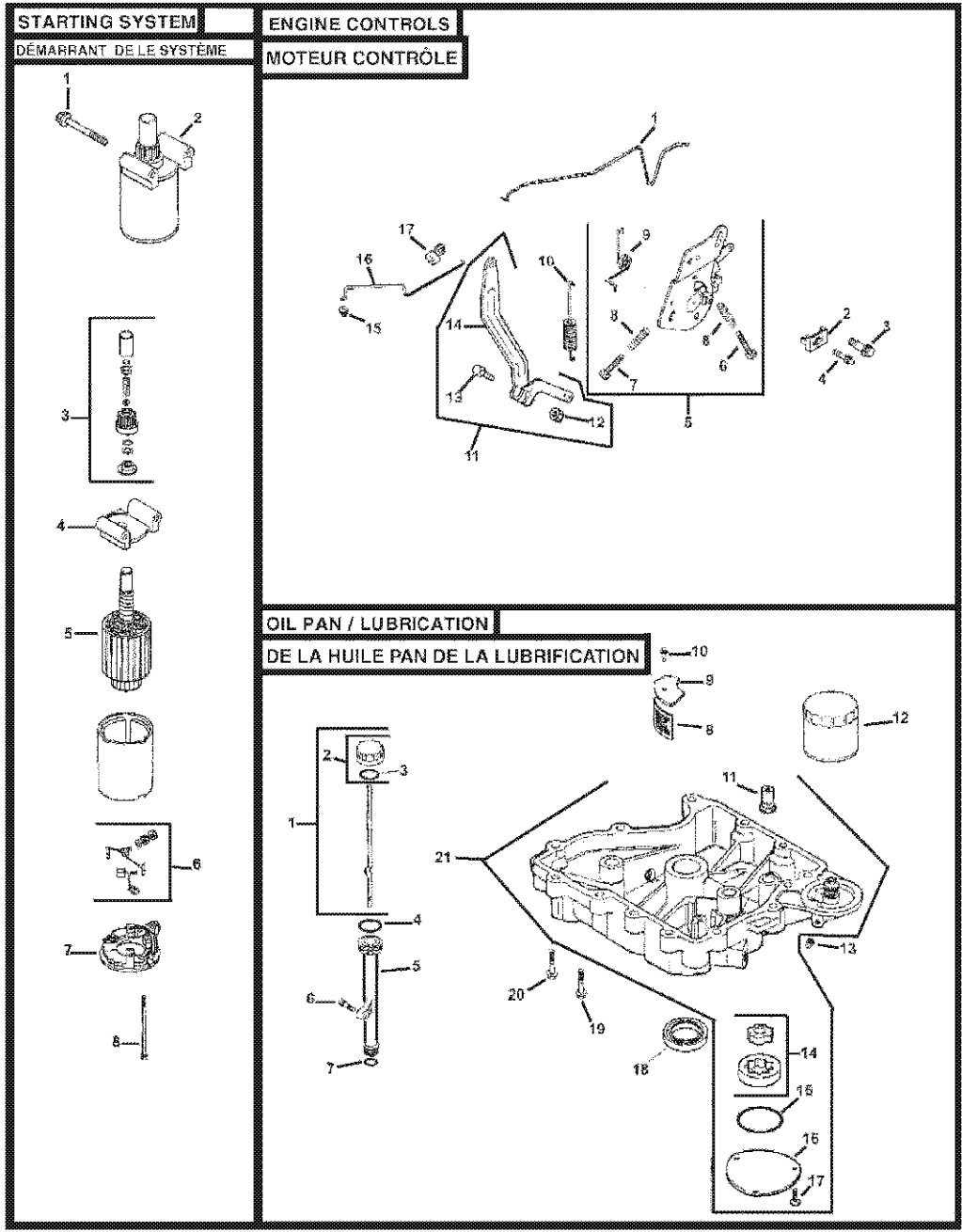

**TRACTOR - - MODEL NUMBER 917.273160
KOHLER ENGINE-MODEL NUMBER CV492, TYPE NUMBER 27506**

STARTING SYSTEM

KEY NO.	PART NO.	DESCRIPTION
1	M-839070-S	Screw, hex. flange M8x1.25x70 (2)
2	25-098-07-S	Starter assembly (Includes 3-8)
3	12-755-54-S	Kit, drive end
4	12-227-18-S	Cap, drive end
5	12-170-05-S	Armature
6	12-221-01-S	Kit, brush & spring
7	12-227-13-S	Cap, commutator end
8	12-211-01-S	Bolt, hex. flange 1/4-20x4- 5/8 (2)

OIL PAN/LUBRICATION

KEY NO.	PART NO.	DESCRIPTION
1	12-038-01-S	Dipstick assembly (Includes 2-3)
2	25-755-13-S	Kit, oil fill cap (Includes 3)
3	12-153-03-S	O-Ring, oil fill cap
4	12-153-02-S	O-Ring, upper oil fill tube
5	12-123-04-S	Tube, oil fill
6	M-645025-S	Screw, hex. flange M6x1.0x25
7	12-153-01-S	O-Ring, lower oil fill tube
8	25-162-07-S	Screen, oil pickup
9	12-096-03-S	Cover, oil pickup screen
10	M-545016-S	Screw, hex. flange M5x0.8x16
11	25-462-09-S	Valve, oil pressure relief
12	52-050-02-S	Filter, oil
13	25-139-57-S	Plug, sq. hd. solid 3/8"
14	12-393-01-S	Pump, oil
15	12-153-06-S	O-Ring, oil pump cover
16	12-096-34-S	Cover, oil pump
17	M-545016-S	Screw, hex. flange M5x0.8x16 (3)
18	12-032-03-S	Seal, oil (P.T.O. end)
19	24-086-16-S	Screw, hex. flange M8x1.25x45 (11)
20	24-086-17-S	Screw, hex. flange M8x1.25x45
21	12-199-56-S	Assembly, Pan, oil (Incl. 11,14-17)

ENGINE CONTROLS

KEY NO.	PART NO.	DESCRIPTION
1	12-079-11-S	Linkage, choke
2	12-237-01-S	Clamp, cable
3	24-086-43-S	Screw, hex. flange
4	M-664020-S	Screw, lobed socket M6x1.0x20 (2)
5	12-536-10-S	Control, speed assembly (Includes 6-9)
6	M-443025-S	Screw, pan head M4x0.7x25
7	M-443020-S	Screw, pan head M4x0.7x20
8	12-089-11-S	Spring, choke (2)
9	12-089-23-S	Spring, choke return
10	12-089-24-S	Spring, governor
11	12-755-83-S	Kit, governor lever (Includes 12-14)
12	12-100-07-S	Nut, hex flange 1/4-20
13	52-211-04-S	Bolt, 1/4-20x1"
14	12-090-28-S	Lever, governor
15	25-158-08-S	Bushing, throttle linkage
16	12-079-10-S	Linkage, throttle
17	25-158-11-S	Bushing, throttle linkage

NOTE: All component dimensions given in U.S.
inches 1 inch = 25.4 mm

TRACTOR - - MODEL NUMBER 917.273160
KOHLER ENGINE-MODEL NUMBER CV492, TYPE NUMBER 27506

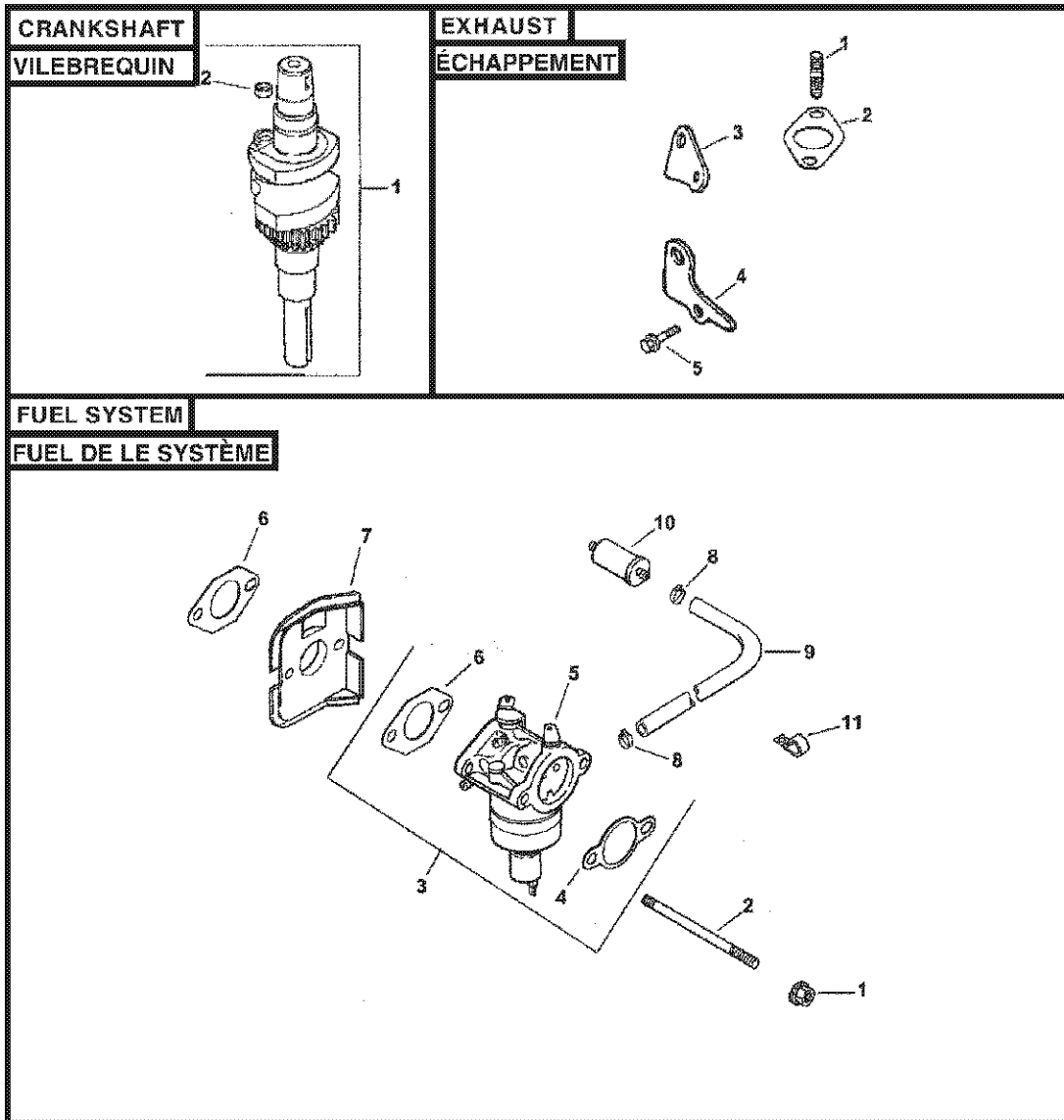

**TRACTOR - - MODEL NUMBER 917.273160
 KOHLER ENGINE-MODEL NUMBER CV492, TYPE NUMBER 27506**

FUEL SYSTEM

KEY NO.	PART NO.	DESCRIPTION
1	M-641060-S	Nut, hex. flange M6x1.0 (2)
2	M-629116-S	Stud M6x1.0x116 (2)
3	12-853-118-S	Kit, carburetor w/gasket (Includes 4,5,6 qty 1 Tie, cable 12-454-03-S, Terminal 25-452-20-S)
4	12-041-02-S	Gasket, air cleaner
5	12-053-118	Carburetor assembly (For information only not available separately) (Includes Kit, float 12-757-02-S Kit, carburetor repair 12-757-03-S, Kit, solenoid repair 12-757-33-S)
6	12-041-01-S	Gasket, carburetor (2)
7	12-265-06-S	Deflector, heat
8	25-237-14-S	Clamp, hose (2)
9	52-353-22-S	Line, fuel 12-1/4"
10	25-050-03-S	Filter, fuel in-line
11	47-154-01-S	Clip cable

NOT ILLUSTRATED

*M-561010-S	Screw, thread forming M5x0.8x10
*X-22-11-S	Washer, lock 1/4"
12-757-02-S	Kit, float
12-757-03-S	Kit, carburetor repair
12-041-01-S	Gasket, carburetor
12-041-02-S	Gasket, air cleaner
12-041-05-S	Gasket, bowl
12-041-06-S	Gasket, bowl screw
12-032-06-S	Seal, solenoid
12-757-33-S	Kit, solenoid repair
12-041-06-S	Gasket, bowl screw
12-454-03-S	Tie cable
25-452-20-S	Terminal
12-518-37-S	Lead, red, (37" - 20 gauge - insulated socket and unin- sulated socket terminals)

*attaches carburetor ground lead to carb baffle.

CRANKSHAFT

KEY NO.	PART NO.	DESCRIPTION
1	12-014-57-S	Crankshaft (Includes 2)
2	25-139-27-S	Plug, cup

EXHAUST

KEY NO.	PART NO.	DESCRIPTION
1	25-072-04-S	Stud, M8x1.25x33(2)
2	12-041-03-S	Gasket, exhaust manifold
3	12-126-11-S	Bracket muffler
4	12-445-06-S	Strap, lifting
5	M-645025-S	Screw, hex. flange M6x1.0x25 (2)
	12 522 49	Short Block
	12-755-93-S	Gasket Set

NOTE: All component dimensions given in U.S. inches 1 inch = 25.4 mm

SERVICE NOTES

SUGGESTED GUIDE FOR SIGHTING SLOPES FOR SAFE OPERATION

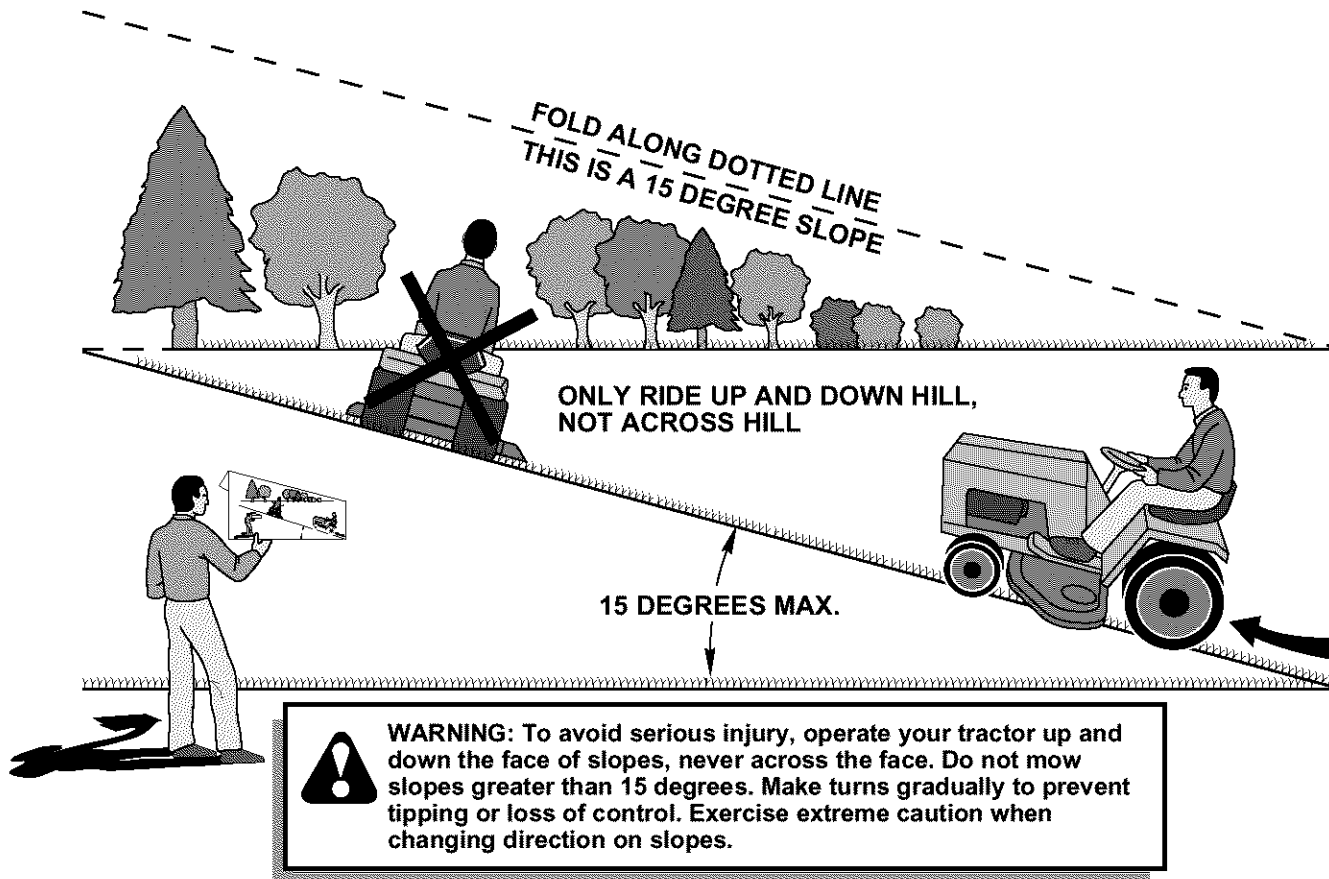

1. Fold this page along dotted line indicated above.
2. Hold page before you so that its left edge is vertically parallel to a tree trunk or other upright structure.
3. Sight across the fold in the direction of hill slope you want to measure.
4. Compare the angle of the fold with the slope of the hill.

Get it fixed, at your home or ours!

Your Home

For repair – **in your home** – of **all** major brand appliances, lawn and garden equipment, or heating and cooling systems, **no matter who made it, no matter who sold it!**

For the replacement parts, accessories and owner's manuals that you need to do-it-yourself.

For Sears professional installation of home appliances and items like garage door openers and water heaters.

1-800-4-MY-HOME[®] Anytime, day or night
(1-800-469-4663) (U.S.A. and Canada)
www.sears.com **www.sears.ca**

Our Home

For repair of carry-in products like vacuums, lawn equipment, and electronics, call or go on-line for the nearest **Sears Parts and Repair Center.**

1-800-488-1222 Anytime, day or night (U.S.A. only)
www.sears.com

To purchase a protection agreement (U.S.A.) or maintenance agreement (Canada) on a product serviced by Sears:

1-800-827-6655 (U.S.A.) **1-800-361-6665** (Canada)

Para pedir servicio de reparación a domicilio, y para ordenar piezas:

1-888-SU-HOGARSM
(1-888-784-6427)

Au Canada pour service en français:

1-800-LE-FOYER^{MC}
(1-800-533-6937)
www.sears.ca

SEARS

© Sears, Roebuck and Co

® Registered Trademark / TM Trademark / SM Service Mark of Sears, Roebuck and Co

® Marca Registrada / TM Marca de Fábrica / SM Marca de Servicio de Sears, Roebuck and Co

^{MC} Marque de commerce / ^{MD} Marque déposée de Sears, Roebuck and Co