

JVC



HOME THEATER DVD-AUDIO/VIDEO RECEIVER

RX-DV31SL

AV COMPU LINK

Digital Direct Progressive Scan

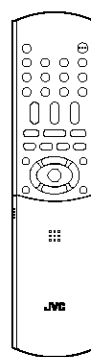
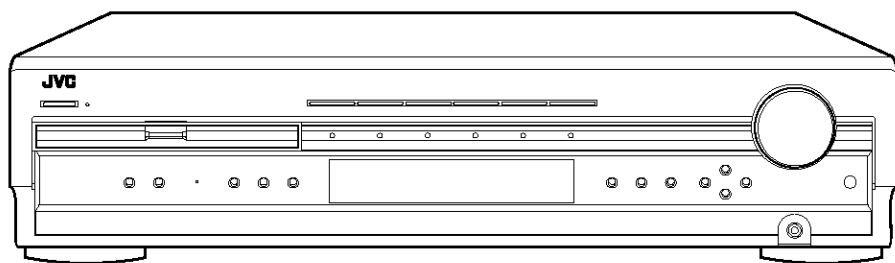

INSTRUCTIONS

For Customer Use:

Enter below the Model No. and Serial No. which are located either on the rear, bottom or side of the cabinet. Retain this information for future reference.

Model No. _____

Serial No. _____

LVT1001-001A

[J]

Warnings, Cautions, and Others

CAUTION

To reduce the risk of electrical shocks, fire, etc.:

1. Do not remove screws, covers or cabinet.
2. Do not expose this appliance to rain or moisture.

Caution —⏻/| STANDBY/ON button!

Disconnect the mains plug to shut the power off completely.

The ⏻/| STANDBY/ON button in any position does not disconnect the mains line.

The power can be remote controlled.

IMPORTANT FOR LASER PRODUCTS

1. CLASS 1 LASER PRODUCT
 2. **CAUTION:** Visible and invisible laser radiation when open and interlock failed or defeated. Avoid direct exposure to beam.
 3. **CAUTION:** Do not open the top cover. There are no user serviceable parts inside the Unit; leave all servicing to qualified service personnel.
-



The lightning flash with arrowhead symbol, within an equilateral triangle is intended to alert the user to the presence of uninsulated "dangerous voltage" within the product's enclosure that may be of sufficient magnitude to constitute a risk of electric shock to persons.



The exclamation point within an equilateral triangle is intended to alert the user to the presence of important operating and maintenance (servicing) instructions in the literature accompanying the appliance.

WARNING: TO REDUCE THE RISK OF FIRE OR ELECTRIC SHOCK, DO NOT EXPOSE THIS APPLIANCE TO RAIN OR MOISTURE.

For U.S.A

This equipment has been tested and found to comply with the limits for a Class B digital device, pursuant to part 15 of the FCC Rules. These limits are designed to provide reasonable protection against harmful interference in a residential installation.

This equipment generates, uses and can radiate radio frequency energy and, if not installed and used in accordance with the instructions, may cause harmful interference to radio communications. However, there is no guarantee that interference will not occur in a particular installation. If this equipment does cause harmful interference to radio or television reception, which can be determined by turning the equipment off and on, the user is encouraged to try to correct the interference by one or more of the following measures:

Reorient or relocate the receiving antenna.

Increase the separation between the equipment and receiver.

Connect the equipment into an outlet on a circuit different from that to which the receiver is connected.

Consult the dealer or an experienced radio/TV technician for help.

Changes or modifications not expressly approved by the manufacturer for compliance could void the user's authority to operate the equipment.

Note to CATV system installer:

This reminder is provided to call the CATV system installer's attention to Section 820-40 of the NEC which provides guidelines for proper grounding and, in particular, specifies that the cable ground shall be connected to the grounding system of the building, as close to the point of cable entry as practical.

Before Installation

Precautions

General Precautions

- DO NOT insert any metal object into the unit.
- DO NOT disassemble the unit or remove screws, covers, or cabinet.
- DO NOT expose the unit to rain or moisture.

Locations

- Install the unit in a location that is level and protected from moisture.
- The temperature around the unit must be between 5°C and 35°C (41°F and 95°F).
- Make sure there is good ventilation around the unit. Poor ventilation could cause overheating and damage the unit.

Handling the unit

- DO NOT touch the power cord with wet hands.
- DO NOT pull on the power cord to unplug it. When unplugging the cord, always grasp the plug so as not to damage the cord.
- Keep the power cord away from the connecting cords and the antenna. The power cord may cause noise or screen interference. It is recommended to use a coaxial cable for antenna connection, since it is well-shielded against interference.
- When a power failure occurs, or when you unplug the power cord, the preset settings such as preset FM or AM channels and sound adjustments may be erased in a few days.

Checking the Supplied Accessories

Check to be sure you have all of the following supplied accessories.

The number in the parentheses indicates the quantity of the pieces supplied.

- **Remote control (1)**
- **Batteries (2)**
- **AM loop antenna (1)**
- **FM antenna (1)**
- **Composite video cord (1)**

If anything is missing, contact your dealer immediately.

- Times given for various operations are for reference only. Actual time will vary somewhat.
- The following mark is used in this manual to indicate available disc types for the operations explained in each section. Unavailable disc types are shown in halftone color.

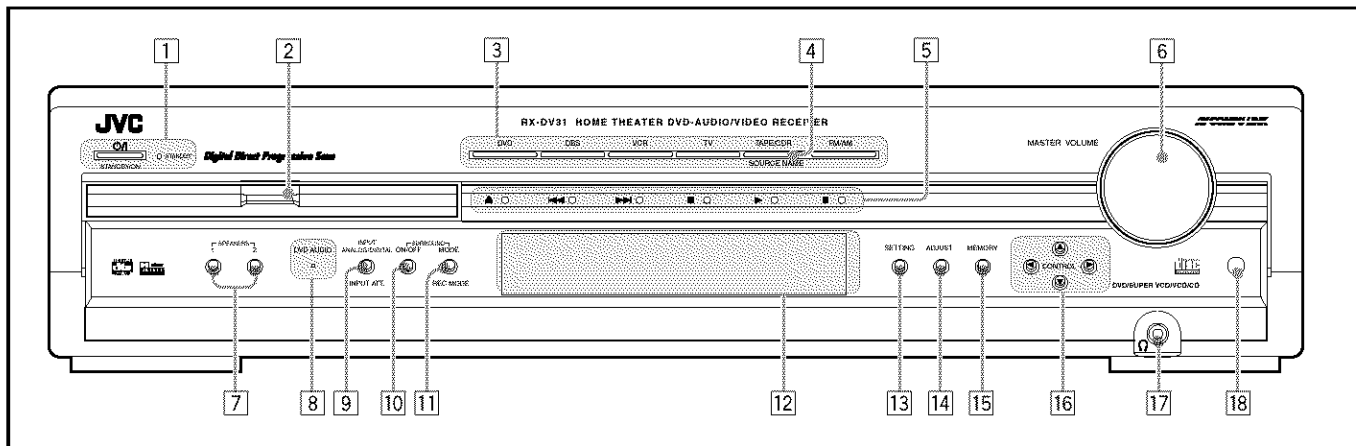

Table of Contents

Parts Identification	3	DVD Player Operations	32
Front Panel	3	Disc Information	32
Remote Control	4	About the On-screen Bar	34
Rear Panel	5	Basic Operation through the On-screen Bar	35
Getting Started	6	Changing the Time Indication	35
Connecting the AM and FM Antennas	6	Locating a Desired Scene from the Disc Menu	36
Connecting the Speakers	7	Selecting a View Angle	37
Connecting Audio/Video Components	8	Selecting the Subtitle Language	37
■ About connecting cords	8	Selecting the Audio Language	38
■ TV connection	9	Selecting the Audio Channel	38
■ DBS tuner connection	9	Playing from a Specified Position on a Disc	39
■ VCR connection	10	■ Locating a desired title/group	39
■ Cassette deck/CD recorder connection	10	■ Locating a desired chapter/track	40
■ Digital connection	11	■ Locating a desired position	40
Putting Batteries in the Remote Control	11	Special Picture Playback	41
Basic Operations	12	■ Still picture and frame-by-frame playback	41
Turning On the Power	12	■ Playing back in slow-motion	41
Selecting the Source to Play	12	■ Selecting browsable still pictures	
Adjusting the Volume	12	recorded on DVD AUDIO	41
■ Listening with headphones	13	■ Zooming in	42
Selecting the Front Speakers	13	■ Playing back a bonus group	42
Changing the Source Name	13	Changing the VFP Setting	43
Turning Off the Sound Temporarily	14	Program Playback	44
Changing the Display Brightness	14	Random Playback	45
Turning Off the Power with the Sleep Timer	14	Repeat Playback	45
Selecting the Analog or Digital Input Mode	14	MP3 Disc Playback	47
■ Changing the digital input mode manually		Basic Operations	47
—for DVD VIDEO only	15	Operations through the MP3 CONTROL Screen	48
Attenuating the Input Signal	15	Repeat Playback	48
Changing the Scanning Mode	16	JPEG Disc Playback	49
Activating the Recording Mode	16	Slide-show Playback	49
Basic DVD Player Operations	17	Operations through the JPEG CONTROL Screen	50
Tuner Operations	19	Repeat Playback	50
Tuning in to Stations Manually	19	Choice Menu Operations	51
Using Preset Tuning	19	■ Language selection menu—LANGUAGE	53
■ Storing preset stations	19	■ Picture setting menu—PICTURE	53
■ Tuning in to a preset station	20	■ Audio selection menu—AUDIO	54
Selecting the FM Reception Mode	20	• Language code list	54
Basic Settings	21	■ Speaker setting menu—SPK. SETTING	55
Setting Speakers Quickly	21	■ Other setting menu—OTHERS	56
Setting Basic Items	22	Restricting Playback by Parental Lock	57
■ Speaker information	23	■ Setting Parental Lock	57
■ Speaker distance	23	■ Changing the Parental Lock setting	58
■ Crossover frequency	24	■ Releasing Parental Lock temporarily	58
■ Low frequency effect attenuator	24	• Country/Area codes list for Parental Lock	59
■ Dynamic range compression	24	Glossary for DVD Player	60
■ Digital input (DIGITAL IN) terminals	25	AV COMPU LINK Remote Control System	61
■ Auto surround	25	Operating JVC's Audio/Video Components ...	63
■ Video output mode	25	Operating Audio Components	63
Sound Adjustments	26	Operating Video Components	64
■ Front speaker output balance	26	Operating Other Manufacturers'	
■ Tone	27	Equipment	65
■ Speaker output levels	27	Changing the Preset Signal Codes	65
■ DAP effect level	27	Maintenance	68
■ Subwoofer audio position	27	Troubleshooting	69
Creating Realistic Sound Fields	28	Specifications	72
Activating Surround Mode	30		
Selecting Surround Modes	30		
Adjusting Surround Mode Using Remote Control	31		

Parts Identification

Front Panel



See pages in the parentheses for details.

- | | |
|--|---|
| <ul style="list-style-type: none"> 1 ϕ/I STANDBY/ON button and STANDBY lamp (12) 2 Disc tray and illumination lamp (17) 3 Source selecting buttons (12) <ul style="list-style-type: none"> • DVD, DBS, VCR, TV, TAPE/CDR, FM/AM 4 SOURCE NAME button (13) 5 DVD player operation buttons (17, 18) <ul style="list-style-type: none"> ▲ (open/close), ◀◀ (reverse skip), ▶▶ (forward skip), ■ (stop), ▶ (play), (pause) 6 MASTER VOLUME control (12, 17) 7 SPEAKERS 1 button (13)
SPEAKERS 2 button (13) 8 DVD AUDIO lamp (17) | <ul style="list-style-type: none"> 9 INPUT ANALOG/DIGITAL button (14) 10 INPUT ATT. (attenuator) button (15) 11 SURROUND ON/OFF button (30) 12 SURROUND MODE button (30) 13 REC (recording) MODE button (16) 12 Display <ul style="list-style-type: none"> • For details, see "Display" below. 13 SETTING button (21, 22) 14 ADJUST button (26) 15 MEMORY button (19, 21) 16 CONTROL ▲/▼/◀▶ buttons (15, 19 – 23, 26) 17 Ω (phones) jack (13) 18 Remote sensor (11) |
|--|---|

Display

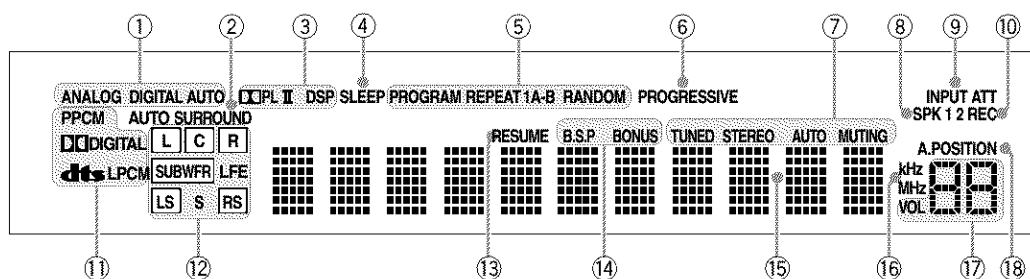

- | | |
|---|---|
| <ul style="list-style-type: none"> 1 Input mode indicators (15) <ul style="list-style-type: none"> • ANALOG, DIGITAL AUTO 2 Surround indicators (30) <ul style="list-style-type: none"> • AUTO SURROUND, SURROUND 3 Surround mode indicators (28, 29) <ul style="list-style-type: none"> • DOLBY II, DSP 4 SLEEP indicator (14) 5 Play mode indicators (44 – 46) <ul style="list-style-type: none"> • PROGRAM, REPEAT 1/A-B, RANDOM 6 PROGRESSIVE indicator (16) 7 Tuner mode indicators (19, 20) <ul style="list-style-type: none"> • TUNED, STEREO, AUTO MUTING 8 Front speaker indicators (13)
SPK 1/2 9 INPUT ATT (attenuator) indicator (15) 10 REC (recording) indicator (16) | <ul style="list-style-type: none"> 11 Sound signal indicators (15) <ul style="list-style-type: none"> • PPCM, DIGITAL (Dolby Digital), dts (DTS Digital Surround), LPCM 12 Signal and speaker indicators (30) <ul style="list-style-type: none"> • L, C, R, SUBWFR (Subwoofer), LFE (Low Frequency Effect), LS, S, RS 13 RESUME indicator (18) 14 DVD AUDIO indicators (17) <ul style="list-style-type: none"> • B.S.P (Browsable Still Picture), BONUS 15 Main display 16 Frequency unit indicators <ul style="list-style-type: none"> • kHz (for AM station), MHz (for FM station) 17 Volume indication 18 A.POSITION (audio position) indicator (27) |
|---|---|

Remote Control

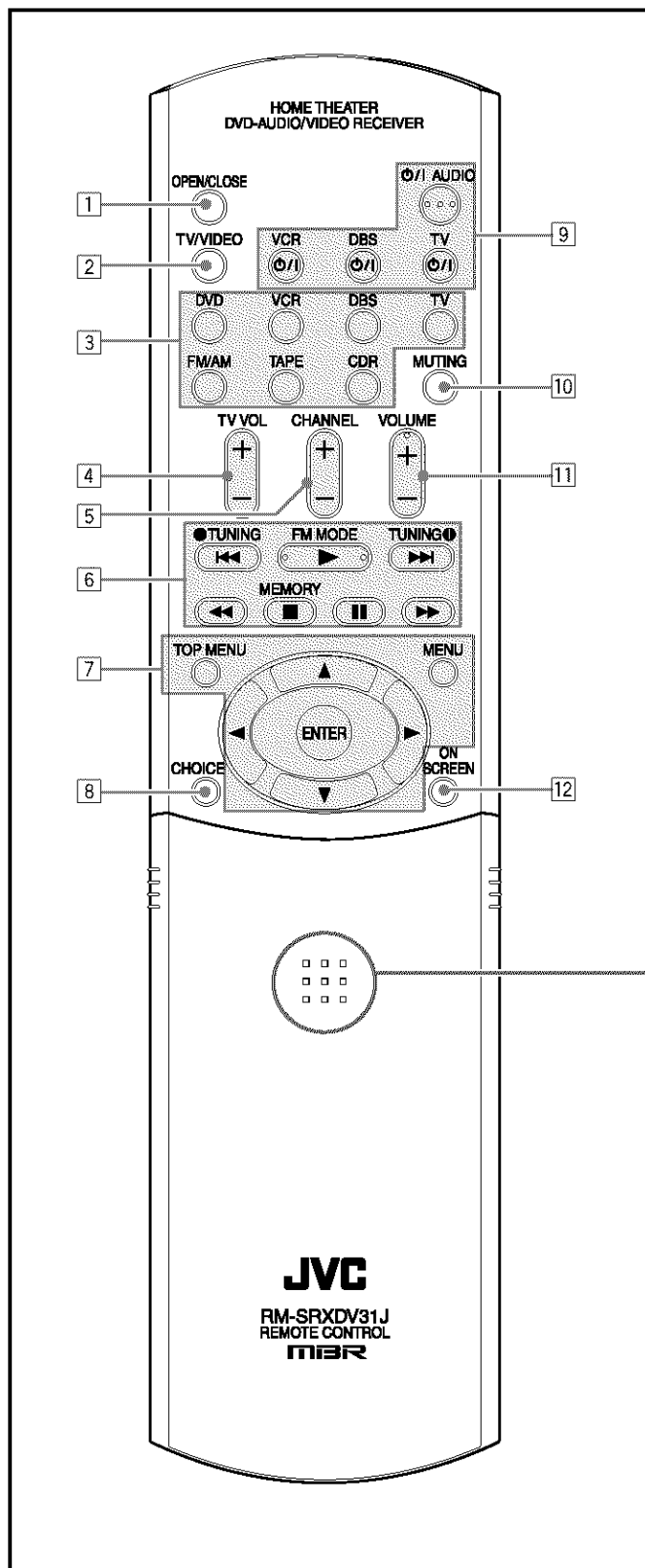

See pages in the parentheses for details.

- 1 OPEN/CLOSE button (17)
- 2 TV/VIDEO button (17, 64, 65)
- 3 Source selecting buttons (12)
 - DVD, VCR, DBS, TV, FM/AM, TAPE, CDR
- 4 TV VOL (volume) +/- button (64, 65)
- 5 CHANNEL +/- button (64 – 66)
- 6 Multi operation buttons
 - ◀◀, ▶▶, ◀▶, ▶◀, ■, ■, ■, ■▶▶▶
 - TUNING ⊕ and ⊖ buttons (19)
 - FM MODE button (20)
 - MEMORY button (20)
- 7 Menu operation buttons
 - TOP MENU button (36)
 - MENU button (36)
 - ENTER button
 - Cursor ▲/▼/▶/◀ buttons
- 8 CHOICE button (51, 52)
- 9 Phi (standby/on) buttons (12, 64 – 67)
 - AUDIO, VCR, DBS, TV
- 10 MUTING button (14)
- 11 VOLUME +/- button (12, 17)
- 12 ON SCREEN button (34, 35, 37 – 41, 44 – 46)

To open the cover of the remote control, push here, then slide downward.

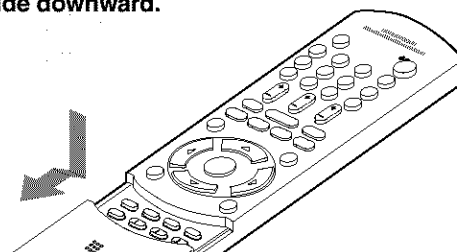

- For buttons inside the cover, see "Remote control—inside the cover" on page 5.

Parts Identification

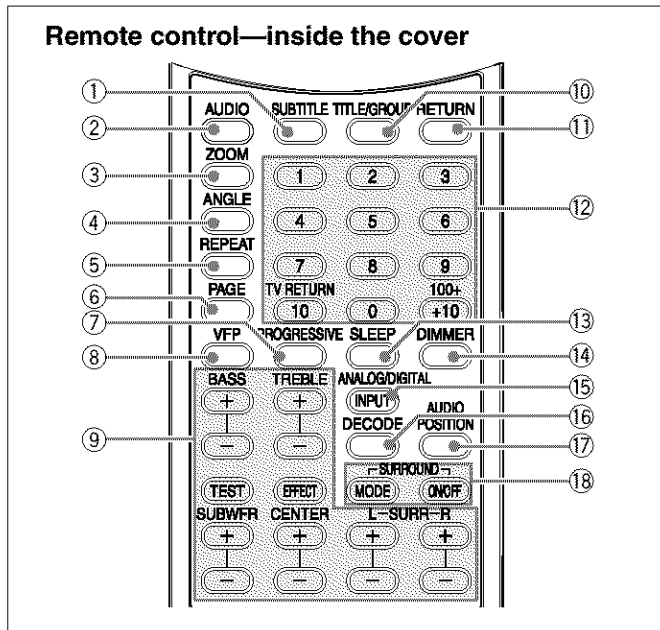

- ① SUBTITLE button (37)
- ② AUDIO button (38)
- ③ ZOOM button (42)
- ④ ANGLE button (37)
- ⑤ REPEAT button (46, 48, 50)

- ⑥ PAGE button (41)
- ⑦ PROGRESSIVE button (16)
- ⑧ VFP button (43)
- ⑨ Sound adjustment buttons (27, 31, 63)
 - BASS + and – buttons
 - TREBLE + and – buttons
 - TEST button
 - EFFECT button
 - SUBWFR (subwoofer) + and – buttons
 - CENTER + and – buttons
 - SURR L (surround left) + and – buttons
 - SURR R (surround right) + and – buttons
- ⑩ TITLE/GROUP button (39, 48, 49)
- ⑪ RETURN button (36)
- ⑫ Number buttons
 - For selecting preset channels (20)
 - For operating audio/video components (64 – 67)
 - TV RETURN button (64, 65)
- ⑬ SLEEP button (14)
- ⑭ DIMMER button (14)
- ⑮ ANALOG/DIGITAL INPUT button (14, 15)
- ⑯ DECODE button (15)
- ⑰ AUDIO POSITION button (27)
- ⑱ Surround buttons (30)
 - SURROUND MODE button
 - SURROUND ON/OFF button

Rear Panel

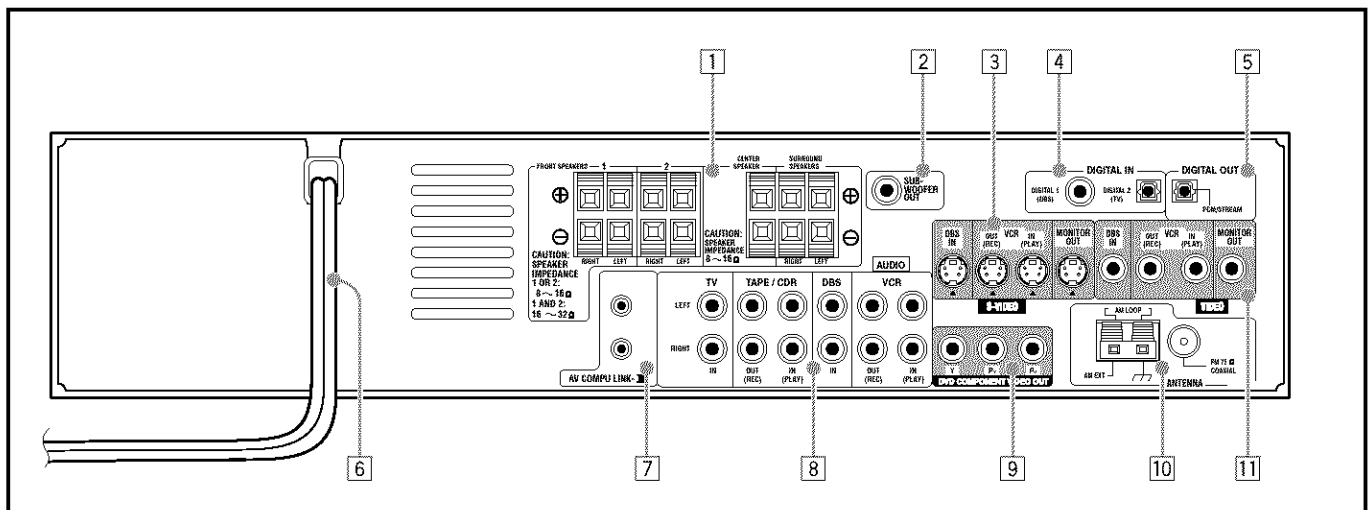

See pages in the parentheses for details.

- ① Speaker terminals (7)
 - FRONT SPEAKERS 1, FRONT SPEAKERS 2, CENTER SPEAKER, SURROUND SPEAKERS
- ② SUB-WOOFER OUT jack (7)
- ③ S-VIDEO input/output terminals (9, 10)
 - Input: DBS IN, VCR IN
 - Output: VCR OUT, MONITOR OUT
- ④ DIGITAL IN terminals (11)
 - Coaxial: DIGITAL 1 (DBS)
 - Optical: DIGITAL 2 (TV)
- ⑤ DIGITAL OUT terminal (11)
- ⑥ Power cord
- ⑦ AV COMPU LINK-III terminals (61)
- ⑧ AUDIO input/output terminals
 - Input: TV IN, TAPE/CDR IN, DBS IN, VCR IN
 - Output: TAPE/CDR OUT, VCR OUT
- ⑨ DVD COMPONENT VIDEO OUT terminals (9)
 - Y/P_b/P_r
- ⑩ FM/AM ANTENNA terminals (6)
- ⑪ VIDEO input/output terminals (9, 10)
 - Input: DBS IN, VCR IN
 - Output: VCR OUT, MONITOR OUT

Getting Started

Connecting the AM and FM Antennas

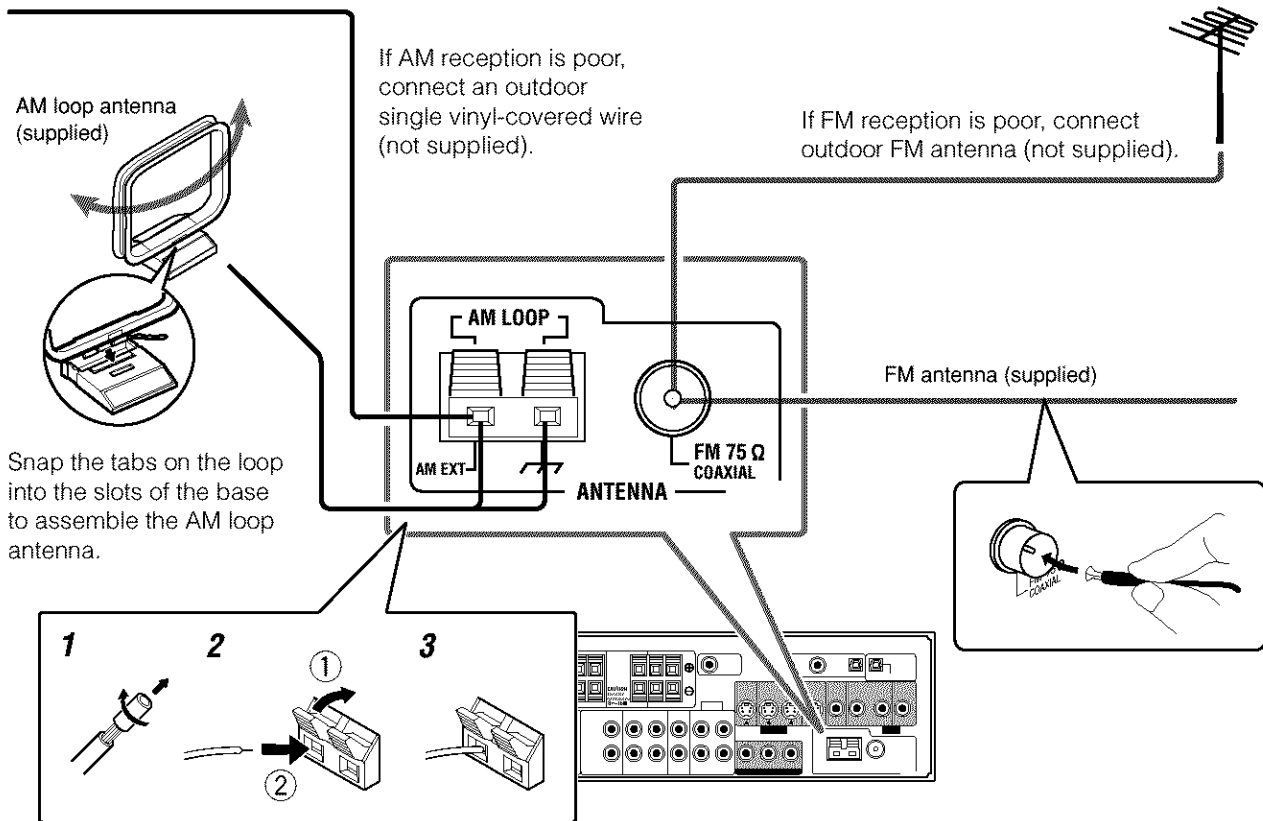

AM antenna connection

Connect the AM loop antenna supplied to the AM LOOP terminals.

- 1 Remove the insulation if the AM loop antenna wire is covered with vinyl.
- 2 Press and hold the clamp of the terminal (①), then insert the wire (②).
- 3 Release the clamp.

Turn the loop until you have the best reception.

- If the reception is poor, connect an outdoor single vinyl-covered wire (not supplied) to the AM EXT terminal. Keep the AM loop antenna connected.

FM antenna connection

Connect the FM antenna supplied to the FM 75 Ω COAXIAL terminal as temporary measure.

Extend the supplied FM antenna horizontally.

- If the reception is poor, connect an outdoor FM antenna (not supplied). Before attaching a 75 Ω coaxial cable with a connector, disconnect the supplied FM antenna.

Note:

- Make sure the antenna conductors do not touch any other terminals, connecting cords and power cord. This could cause poor reception.

Getting Started

Connecting the Speakers

You can connect following speakers to this unit:

- two pairs of front speakers
 - FRONT SPEAKERS 1 terminals
 - FRONT SPEAKERS 2 terminals
- a pair of surround speakers
- a center speaker
- a subwoofer

CAUTIONS:

- Use speakers with the SPEAKER IMPEDANCE indicated by the speaker terminals.
- DO NOT connect more than one speaker to one speaker terminal.

Connection diagram

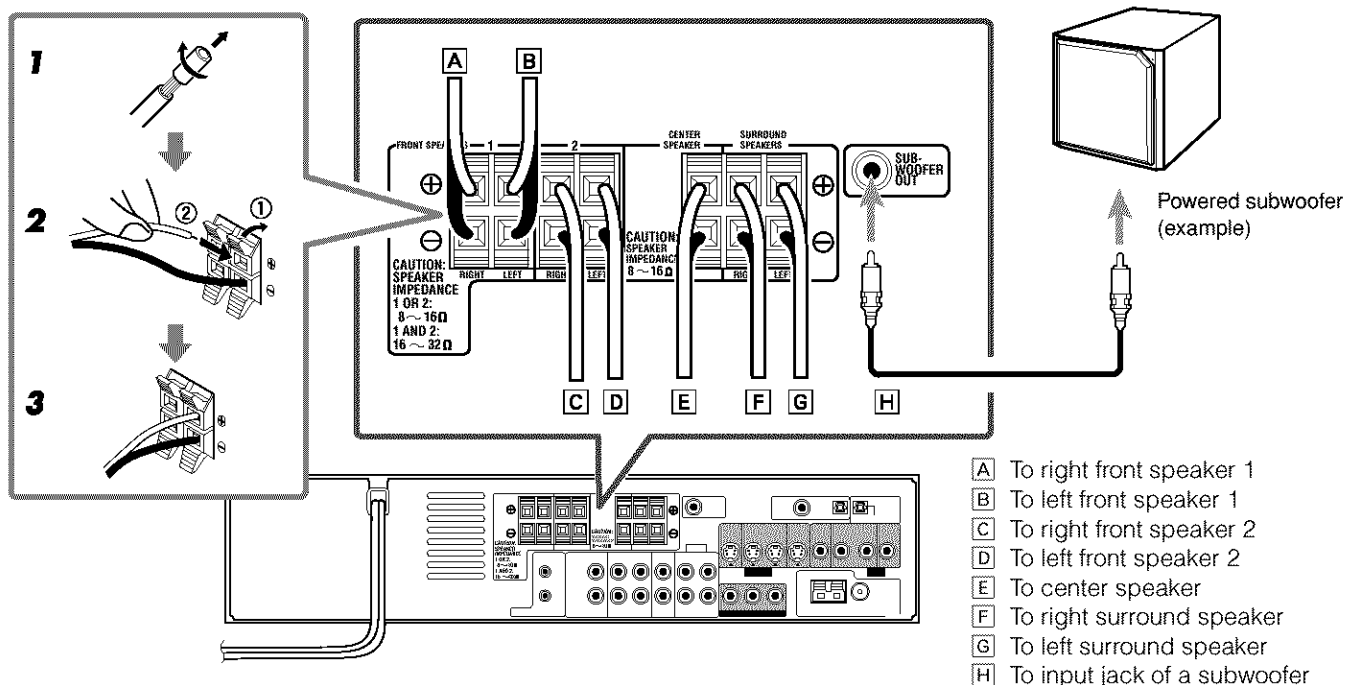

How to connect speakers cords

For each speaker, connect the (+) and (-) terminals on the rear panel to the (+) and (-) terminals marked on the speakers respectively.

- 1 Twist and remove the insulation at the end of each speaker cord (not supplied).
- 2 Press and hold the clamp of the speaker terminal (①), then insert the speaker cord (②).
- 3 Release the clamp.

About the speaker impedance

The required speaker impedance of the front speakers differs depending on whether both the FRONT SPEAKERS 1 and FRONT SPEAKERS 2 terminals are used or only one of them is used.

- When you connect only one pair of front speakers, use front speakers with 8 Ω – 16 Ω impedance.
- When you connect both pairs of front speakers, use front speakers with 16 Ω – 32 Ω impedance.

Connecting the subwoofer speaker

By connecting a subwoofer, you can enhance the bass or reproduce the original LFE signals recorded in the digital software.

Connect the input jack of a powered subwoofer to the SUBWOOFER OUT jack on the rear panel, using a cable with RCA pin plugs (not supplied).

- Refer also to the manual supplied with your subwoofer.

Note:

- You can place a subwoofer wherever you like since bass sound is non-directional. Normally place it in front of you.

To obtain the best possible sound from this system, place all the speakers except the subwoofer at the same distance from the listening position with each speaker's front faced toward the listener.

Then, change the subwoofer and speaker settings to fit your listening conditions (see pages 22 to 24).

- You can set the speakers quickly according to the number of speakers you have connected. See "Setting Speakers Quickly" on page 21.

Connecting Audio/Video Components

Turn off all the components and the unit before connection.

- Illustrations of the input/output terminals below are typical examples. When you connect other components, refer also to their manuals since the terminal names actually printed on their rear vary among the components.

■ About connecting cords

For video connections

The S-video cords and the component video cord are not supplied with this unit.

Use the cords supplied with the other components or purchase them at your dealer.

A Composite video cord (supplied)



B S-video cord (not supplied)



C Component video cord (not supplied)

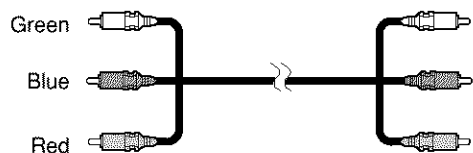

For audio connections

Connect the external components to this unit with the audio cords.

Use the cord supplied with the other components or purchase them at your dealer.

A Digital coaxial cord (not supplied)



B Optical digital cord (not supplied)



C Audio cord (not supplied)

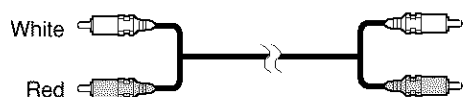

Notes for video connection

- You can use composite video cord or S-video cord for connecting the DBS tuner and VCR to this unit.
- You can use component video cord in addition to composite video cord and S-video cord for connecting your TV to this unit.
- By using S-video cord or component video, you can get a better picture quality—in the order: composite < S-video < component.
- To view the picture from DBS tuner or VCR on your TV, connect your TV to this unit using the same type of cord for connecting the DBS tuner or VCR to this unit.
- To view the picture from the built-in DVD player, connect the TV to this unit using composite video cord, S-video cord, or component video cord, then register the video output mode correctly (see "Video output mode" on page 25).
- To enjoy the progressive video picture, connect the TV compatible with the progressive video input using component video cord, then change the scanning mode correctly (see "Changing the Scanning Mode" on page 16).

Notes for digital connection

- When the unit is shipped from the factory, the DIGITAL IN terminals are set for use with the following components:
 - DIGITAL 1 (coaxial): For DBS tuner
 - DIGITAL 2 (optical): For TV
- If you connect the CD recorder, change the digital input (DIGITAL IN) terminal setting (see "Digital input (DIGITAL IN) terminals" on page 25) and the source name (see "Changing the Source Name" on page 13) correctly.
- Select the digital input mode correctly (see "Selecting the Analog or Digital Input Mode" on page 14).

Getting Started

Turn off all the components and the unit before connection.

- Illustrations of the input/output terminals below are typical examples. When you connect other components, refer also to their manuals since the terminal names actually printed on their rear vary among the components.

TV connection

DO NOT use a TV through a VCR or a TV with a built-in VCR; Otherwise, the picture may be distorted.

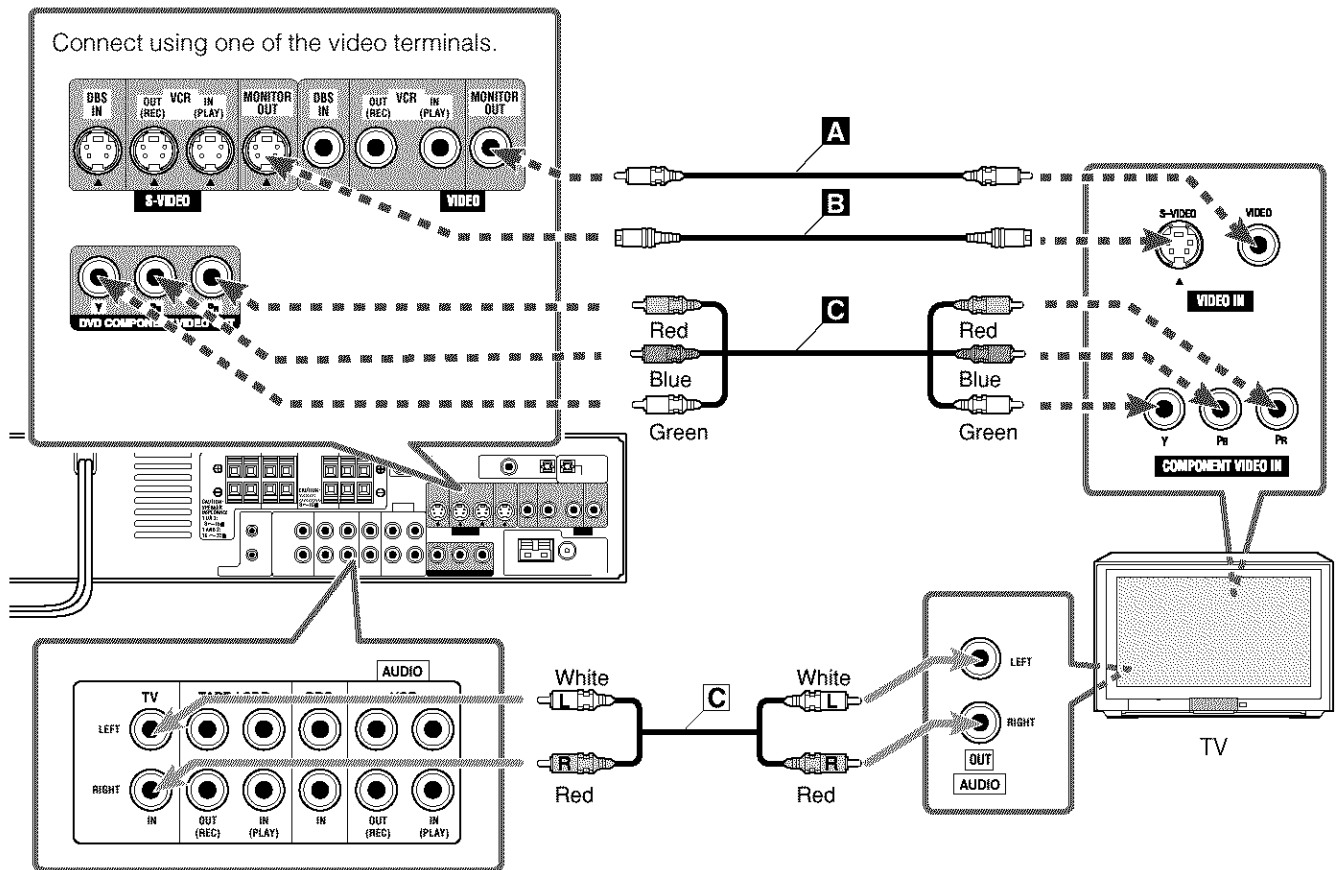

DBS tuner connection

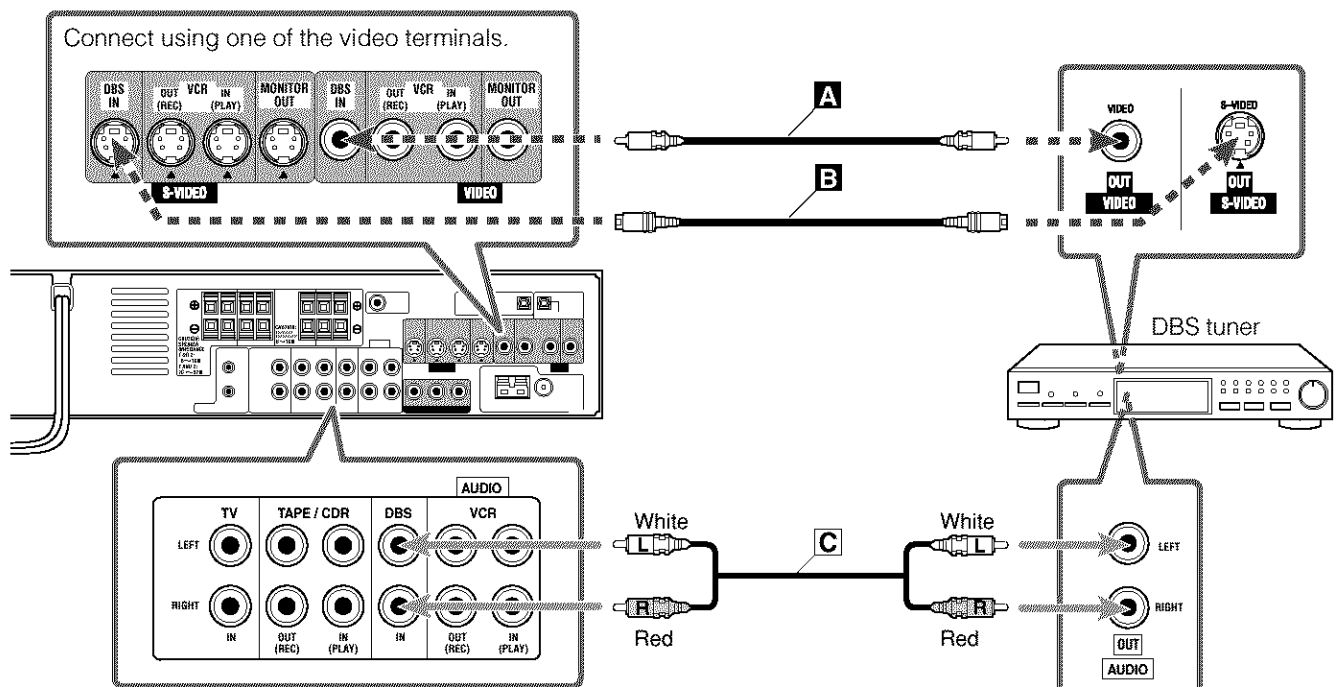

■ VCR connection

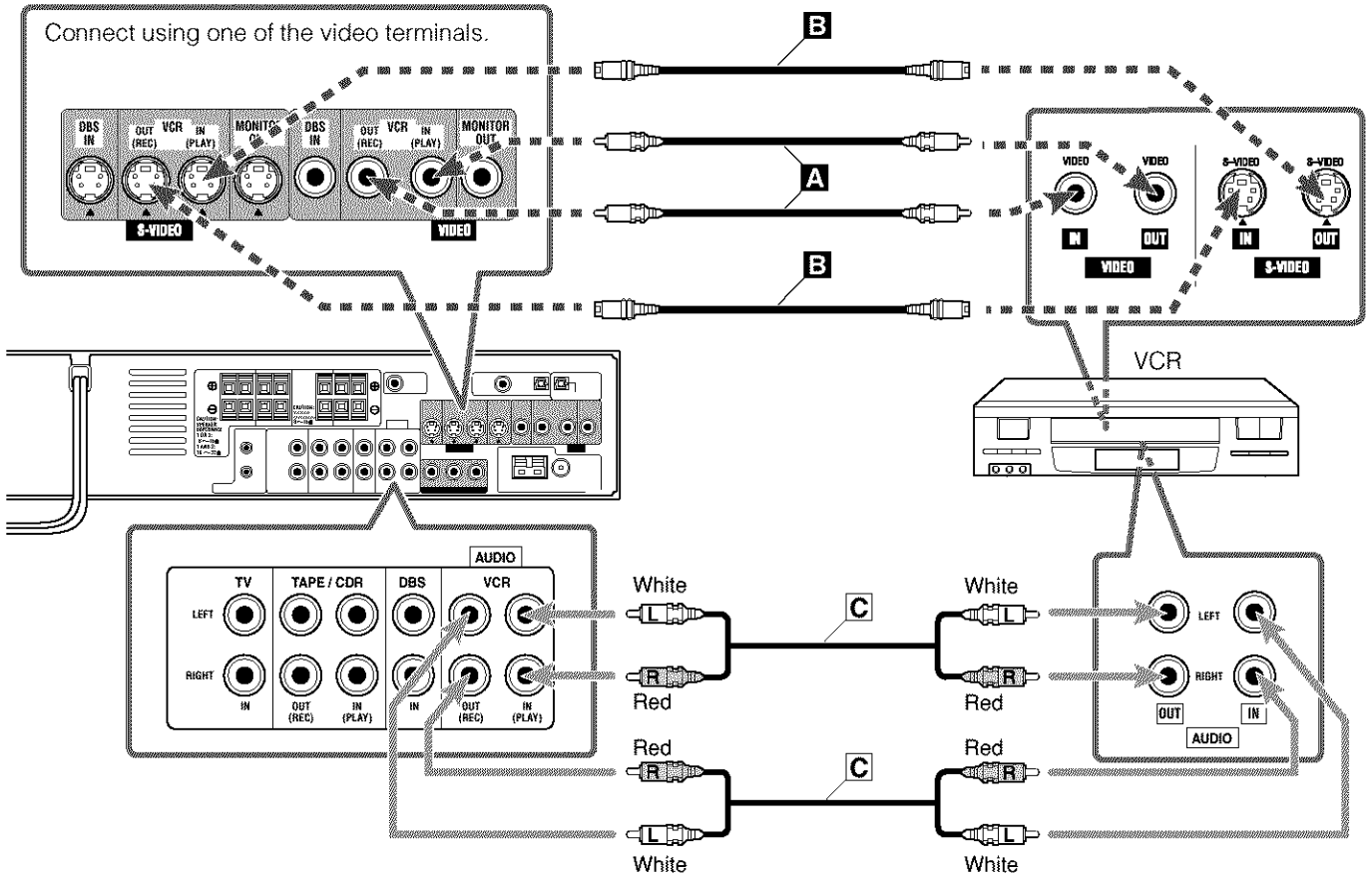

■ Cassette deck/CD recorder connection

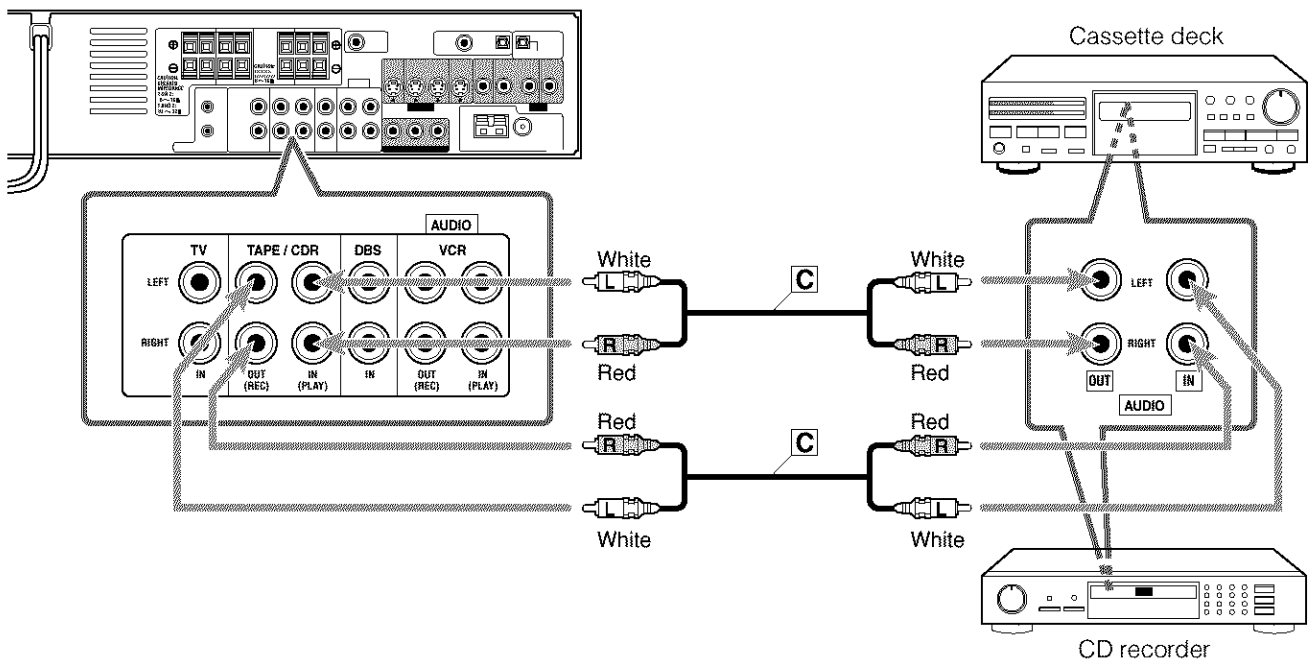

Getting Started

■ Digital connection

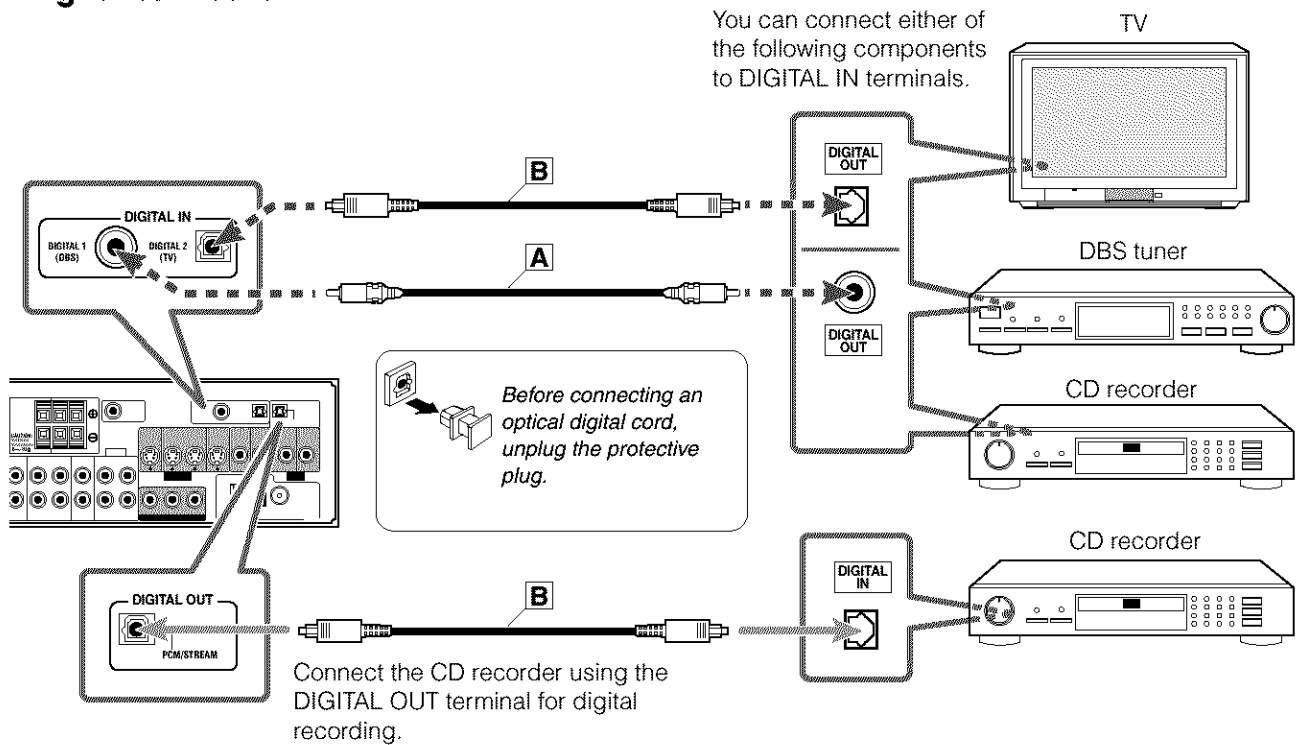

Now, you can plug the power cord of the unit into the AC outlet.

CAUTIONS:

- Do not touch the power cord with wet hands.
- Do not pull on the power cord to unplug the cord. When unplugging the cord, always grasp the plug so as not to damage the cord.

Notes:

- Keep the power cord away from the connecting cords and the antenna cables. The power cord may cause noise or screen interference.
- The preset settings such as preset channels and sound adjustment may be erased in a few days in the following cases:
 - When you unplug the power cord.
 - When a power failure occurs.

Putting Batteries in the Remote Control

Before using the remote control, put two supplied batteries first.

1 Press and slide the battery cover on the back of the remote control.

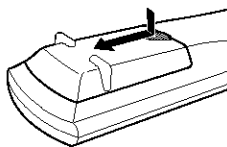

2 Insert batteries. Make sure to match the polarity: (+) to (+) and (-) to (-).

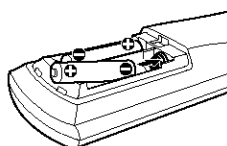

3 Replace the cover.

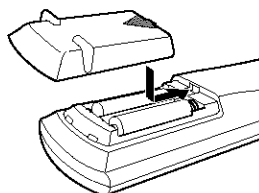

If the range or effectiveness of the remote control decreases, replace the batteries. Use two R6P(SUM-3)/AA(15F) type dry-cell batteries.

Note:

Supplied batteries are for the initial setup. Replace for continued use.

CAUTION:

Follow these precautions to avoid leaking or cracking cells:

- Place batteries in the remote control so they match the polarity: (+) to (+) and (-) to (-).
- Use the correct type of batteries. Batteries that look similar may differ in voltage.
- Always replace both batteries at the same time.
- Do not expose batteries to heat or flame.

When using the remote control, aim the remote control directly at the remote sensor on the unit.

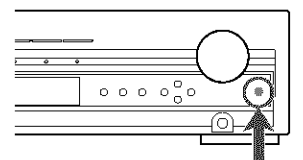

Remote sensor

Basic Operations

Turning On the Power

Press **⏻/⏻ STANDBY/ON** on the front panel or **⏻/⏻ AUDIO** on the remote control.

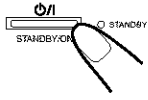

On the front panel

From the remote control

The STANDBY lamp goes off and the illumination lamp lights up.

The current source name appears on the display.

- If "DVD" is the current source, "READING" appears while the unit is detecting the type of the loaded disc (see page 32).
 - Playback starts automatically when you load some DVD VIDEO.
 - "NO DISC" appears on the display when no disc is loaded.

To turn off the power (into standby)

Press **⏻/⏻ STANDBY/ON** on the front panel or **⏻/⏻ AUDIO** on the remote control again.

The illumination lamp goes off and the STANDBY lamp lights up.

Note:

- A small amount of power is consumed even in standby mode. To turn off the power completely, unplug the AC power cord.

Selecting the Source to Play

Press one of the source selecting buttons.

On the front panel



From the remote control



- | | |
|-----------------|---|
| DVD | Select the built-in DVD player. |
| DBS | Select the DBS tuner. |
| VCR | Select the VCR. |
| TV | Select the TV tuner. |
| TAPE/CDR | Select the cassette deck or the CD recorder (front panel ONLY). |
| TAPE* | Select the cassette deck (remote control ONLY). |
| CDR* | Select the CD recorder (remote control ONLY). |
| FM/AM | Select an FM or AM broadcast. |

Notes:

- When you have connected some digital components using the digital terminals (see page 11), register the digital input terminal setting (see "Digital input (DIGITAL IN) terminals" on page 25) and digital input mode setting correctly (see "Selecting the Analog or Digital Input Mode" on page 14). Source name and "DIGITAL" will be shown on the display when you select the source.
- * You can use only one of the buttons—TAPE or CDR—whichever the source name is activated (see "Changing the Source Name" on page 13).

Adjusting the Volume

On the front panel

To increase the volume, turn MASTER VOLUME clockwise.

To decrease the volume, turn MASTER VOLUME counterclockwise.

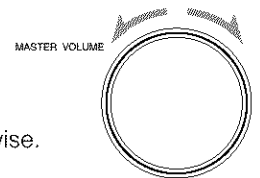

From the remote control

To increase the volume, press and hold VOLUME +.

To decrease the volume, press and hold VOLUME -.



CAUTION:

Always set the volume to the minimum before starting any source. If the volume is set at a high level, the sudden blast of sound energy can permanently damage your hearing and/or ruin your speakers.

Notes:

- The volume level can be adjusted within the range of "0" (minimum) to "50" (maximum).
- When "DVD" is selected as the source with your TV turned on, the volume level indication appears on the TV.

Basic Operations

■ Listening with headphones

Connect a pair of headphones to the Ω (phones) jack on the front panel. This cancels the Surround mode currently selected, deactivates speakers, and activates the HEADPHONE mode.

The SPK 1 and 2 indicators go off from the display.

- Disconnecting a pair of headphones from the Ω (phones) jack cancels the HEADPHONE mode and activates speakers.

HEADPHONE mode

When using the headphones, the following signals are output regardless of your speaker setting:

- **For 2-channel sources**, the front left and right channel signals are output directly from the left and right headphones.
- **For multi-channel sources**, the front left and right, center, and surround channel signals are down-mixed and then output from the headphones without missing bass element.
- **For DVD AUDIO ONLY:** When down-mixing is prohibited on the disc, only signals of the front left and right channel are output.

CAUTION:

Be sure to turn down the volume:

- Before connecting or putting on headphones, as high volume can damage both the headphones and your hearing.
- Before removing headphones, as high volume may come out of the speakers.

Selecting the Front Speakers

When you have connected two pairs of front speakers, you can select which to use.

On the front panel ONLY

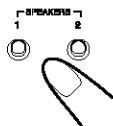

To use the speakers connected to the FRONT SPEAKERS 1 terminals

Press SPEAKERS 1 so that the SPK 1 indicator lights up on the display. (Make sure that SPK 2 is not lit on the display.)

To use the speakers connected to the FRONT SPEAKERS 2 terminals

Press SPEAKERS 2 so that the SPK 2 indicator lights up on the display. (Make sure that SPK 1 is not lit on the display.)

To use both pairs of the speakers

Press SPEAKERS 1 and 2 so that the SPK 1 and 2 indicators light up on the display.

To use neither pairs of the speakers

Press SPEAKERS 1 and 2 so that the SPK 1 and SPK 2 indicators go off from the display.

Notes:

- If you select any of the Surround modes while using both pairs of the front speakers connected to the FRONT SPEAKERS 1 and 2 terminals, the speakers connected to the FRONT SPEAKERS 2 terminals are deactivated.
- While the Surround mode is in use, you can only select either the speakers connected to the FRONT SPEAKERS 1 or 2 terminals.

Changing the Source Name

When you connect a CD recorder to the TAPE/CDR jacks on the rear panel, change the source name which will be shown on the display.

On the front panel ONLY



Ex.: When changing the source name from "TAPE" to "CDR"

1 Press TAPE/CDR (SOURCE NAME) to select as the source.

2 Press and hold SOURCE NAME (TAPE/CDR) until "ASSGN. CDR" appears on the display.

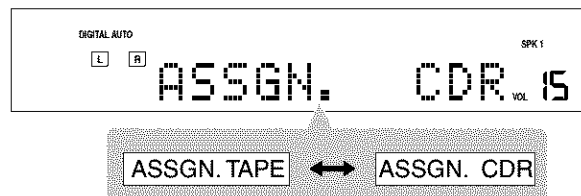

To change the source name to "TAPE"

Press and hold SOURCE NAME (TAPE/CDR) until "ASSGN. TAPE" appears on the display in step 2.

Note:

- Without changing the source name, you can still use the connected components. However, there may be some inconveniences:
 - The unexpected source name will appear on the display when you press TAPE/CDR (SOURCE NAME) on the front panel.
 - The CDR or TAPE button on the remote control will not work for selecting the source.
 - You cannot use the digital input (see page 25) for the CD recorder.

Turning Off the Sound Temporarily

From the remote control ONLY

Press **MUTING** to mute the sound.



"MUTING" appears on the display and the volume turns off (the volume indication goes off).

- When "DVD" is selected as the source with your TV turned on, "VOLUME –" appears on the TV.



To restore the sound

Press **MUTING** again.

- Pressing **VOLUME +** or **–** on the remote control (or turn **MASTER VOLUME** on the front panel) also restores the sound.

Changing the Display Brightness

From the remote control ONLY

Press **DIMMER** to dim the display.



- Each time you press the button, the display and illumination lamp dim and brighten alternately.

Turning Off the Power with the Sleep Timer

From the remote control ONLY

Press **SLEEP** repeatedly.



The **SLEEP** indicator lights up on the display.

- Each time you press the button, the shut-off time changes as follows:

SLEEP indicator



10 → 20 → 30 → 60 →
90 → 120 → 150 → 0 (off) →
(back to the beginning)

When the shut-off time comes

The unit is turned off automatically.

To check or change the remaining time until the shut-off time

Press **SLEEP** once.

- The remaining time (in minutes) until the shut-off time appears.

To change the shut-off time

Press **SLEEP** repeatedly.

To cancel the Sleep Timer

Press **SLEEP** repeatedly until "SLEEP 0" appears on the display. (The **SLEEP** indicator goes off.)

- Turning off the unit also cancels the Sleep Timer.

Note:

- If *Auto Standby* (see page 56) and *Sleep Timer* are used at the same time, the one with the earlier shut-off time will turn off the unit.

Selecting the Analog or Digital Input Mode

When you have connected digital source components using both the analog connection and the digital connection methods (see pages 9 to 11), you can select the input mode.

- Before selecting the digital input mode, register the digital input terminal setting correctly (see "Digital input (DIGITAL IN) terminals" on page 25).

Note:

- You cannot change the input mode when selecting "DVD" as the source. Digital input is always used for the built-in DVD player.

- 1 Press one of the source selecting buttons (**DBS**, **TV**, or **CDR**) for which you want to change the input mode.
- 2 Press **INPUT ANALOG/DIGITAL (INPUT ATT.)** on the front panel or **ANALOG/DIGITAL INPUT** on the remote control.

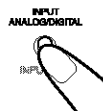

On the front panel



From the remote control

The current input mode appears on the display.

- Each time you press the button, the input mode alternates between the analog input ("ANALOG") and the digital input ("DGTL AUTO").

DIGITAL AUTO indicator



DGTL AUTO ↔ ANALOG

TO BE CONTINUED TO THE NEXT PAGE

Basic Operations

DGTL AUTO	Select for the digital input mode. The DIGITAL AUTO indicator lights up. The unit automatically detects the incoming signal format, then the sound signal indicator for the detected signal (see below) lights up; otherwise, no sound signal indicators light up.
ANALOG	Select for the analog input mode (initial setting except for the built-in DVD player). The ANALOG indicator lights up.

DGTL D.D.	Select for playing back software encoded with Dolby Digital. The DIGITAL indicator lights up*.
DGTL DTS	Select for playing back software encoded with DTS. The dts indicator lights up*.

* These indicators flash when no signal or a signal without the proper format is played back.

Sound signal indicators on the display

PPCM	Light when DVD AUDIO Packed PCM signals come in.
DIGITAL	<ul style="list-style-type: none"> • Light when Dolby Digital signals come in. • Flash when "DGTL D.D." is selected for software not encoded with Dolby Digital signals.
dts	<ul style="list-style-type: none"> • Light when DTS signals come in. • Flash when "DGTL DTS" is selected for software not encoded with DTS signals.
LPCM	Light when Linear PCM signals come in.

You can also change the digital input mode by pressing **DECODE** repeatedly on the remote control.

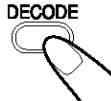

Notes:

- When "DGTL AUTO" cannot recognize the incoming signals, no sound signal indicators light up on the display.
- When you turn off the unit or select another source, "DGTL DTS" and "DGTL D.D." are canceled. The digital input mode is automatically reset to "DGTL AUTO."

Changing the digital input mode manually—for DVD VIDEO only

If the following symptoms occur while Dolby Digital or DTS software is played back, try changing the digital input mode:

- Sound does not come out at the beginning of playback.
- Noise comes out while searching for or skipping chapters or tracks.

1 Press **INPUT ANALOG/DIGITAL (INPUT ATT.)** on the front panel or **ANALOG/DIGITAL INPUT** on the remote control to select "DGTL AUTO."



On the front panel



From the remote control

2 Press **CONTROL** (or **◀**) to select "DGTL D.D." or "DGTL DTS" while "DGTL AUTO" still remains on the display.



- Each time you press the button, the digital input mode changes as follows:

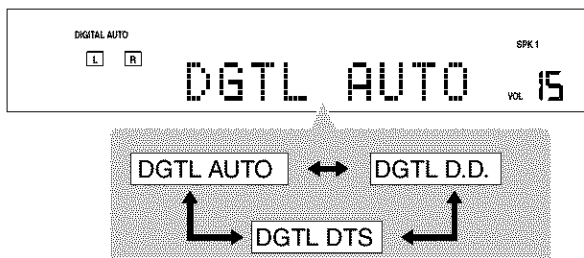

Attenuating the Input Signal

When the input level of the analog source is too high, the sounds will be distorted. If this happens, attenuate the input signal level to prevent this sound distortion.

- You have to make this adjustment for each analog source.

On the front panel ONLY



Press and hold **INPUT ATT. (INPUT ANALOG/DIGITAL)** until the **INPUT ATT** indicator lights up on the display.

- Each time you press and hold the button, the Input Attenuator turns on ("ATT ON") or off ("ATT NORMAL").

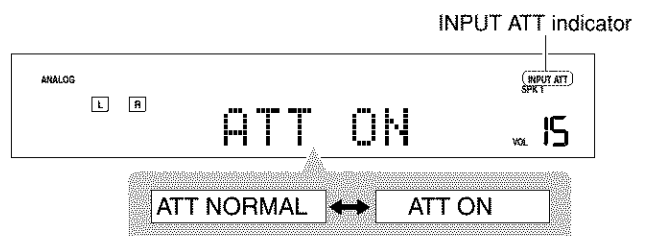

ATT NORMAL Normally select this (initial setting). The analog sound is not attenuated.

ATT ON Select when the analog sound is distorted.

Changing the Scanning Mode

This unit supports the progressive scanning system (480p*) as well as the conventional interlaced scanning system (480i*).

If your TV has component video jacks and supports progressive video input, you can enjoy a high quality picture from the built-in DVD player.

- Refer also to the instruction manuals supplied with your TV.
- You can select the picture source according to the original picture type (film or video source). See "PICTURE SOURCE" on page 53.
- Do not change the scanning mode to "PROGRESSIVE" in the following cases:
 - When your TV does not support the progressive video input.
 - When you are not connecting your TV to the unit using a component video cord.

From the remote control ONLY

PROGRESSIVE



Press **PROGRESSIVE** when "DVD" is selected as the source.

- Each time you press the button, the scanning mode changes between "INTERLACE" and "PROGRESSIVE."

INTERLACE	Select for conventional TV (initial setting).
PROGRESSIVE	Select if your TV with component jacks supports the progressive video input. The PROGRESSIVE indicator lights up.

Notes:

- Some progressive TVs and High-Definition TVs are not fully compatible with this system. When an incompatible picture is played back, change the scanning mode to "INTERLACE." To check the compatibility of your TV, contact your dealer. All JVC progressive TVs and High-Definition TVs are fully compatible with this system.
- When you select "PROGRESSIVE" as the scanning mode, the picture does not come out correctly through composite video and S-video jacks.
- * 480p and 480i indicate the number of scanning lines and scanning format of an image signal.
 - 480p indicates 480 scanning lines with progressive format.
 - 480i indicates 480 scanning lines with interlaced format.

Activating the Recording Mode

When you play back the multi-channel sources, Recording mode enables you to record the sounds without missing surround elements by down-mixing the center and surround channel signals into the front channel signals.

- When multi-channel software is played back with Recording mode activated, the sounds are down-mixed and come out through the front speakers only.
- **For DVD AUDIO ONLY:** When down-mixing is prohibited on the disc, this function does not take effect.

On the front panel ONLY



Press and hold **REC MODE (SURROUND MODE)** until "RECMODE ON" appears on the display.

The REC indicator lights up on the display.

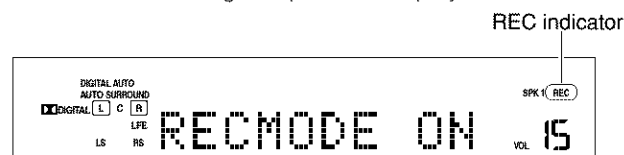

- Each time you press and hold the button, Recording mode is activated ("RECMODE ON") and deactivated ("RECMODE OFF") alternately.

RECMODE OFF Normally select this (initial setting). Down-mixing is canceled.

RECMODE ON Select for recording down-mixed sounds.

When recording onto the VCR:

You can record the picture on your video tape without the volume level indication on the TV when Recording mode is activated.

- When you do not want to record the on-screen guide icons, see page 56.
- The choice menu (see page 51) and on-screen bar (see page 34) are always recorded when they appear on the TV.

CAUTION:

Sound coming out of the speakers may be distorted by Recording mode. In this case, decrease the volume until the sound distortion diminishes.

Notes:

- When you turn off the unit or select another source, Recording mode is canceled ("RECMODE OFF").
- Sound adjustments (see pages 26 and 27) and Surround modes (see pages 28 to 31) do not affect the recording.
- The following buttons do not work while Recording mode is activated ("RECMODE ON"):
 - SETTING and ADJUST on the front panel
 - SURROUND ON/OFF and SURROUND MODE on the front panel
 - Sound adjustment buttons on the remote control

Basic DVD Player Operations

For details about DVD player operations, see pages 32 to 46.

- You can also play back MP3 and JPEG files. See pages 47 to 50.
- Before using the remote control, press DVD so that the remote control works for the DVD player.

Before turning on the unit, turn on your TV and select the correct video input (refer to the manual supplied with your TV).

- When you use a JVC's TV, you can turn on your TV by pressing TV ON/OFF on the remote control and select the video input by pressing TV/VIDEO. (If your TV is not a JVC, see "Operating Other Manufacturers' Equipment" on page 65.)
- For changing the OSD messages—the information on the TV—into the desired language, see pages 51 to 53.

1 Press \blacktriangle on the front panel or OPEN/CLOSE on the remote control to open the disc tray.



On the front panel From the remote control

The unit is turned on and the disc tray opens. The STANDBY lamp goes off and the illumination lamp lights up.

- When a disc is already loaded, pressing \blacktriangleright turns on the unit and starts playing back the loaded disc.

2 Load a disc.

Place a disc correctly with its label side up.

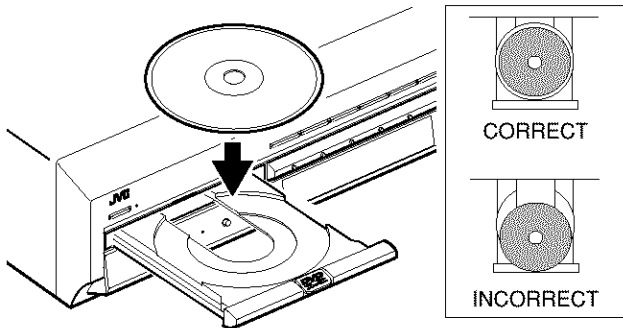

3 Press \blacktriangleright .

The disc tray closes and the unit starts playing back the loaded disc.

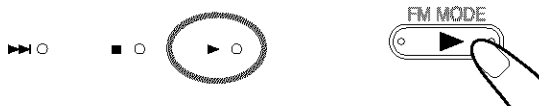

On the front panel From the remote control

- You can also close the disc tray by pressing \blacktriangle on the front panel or OPEN/CLOSE on the remote control.

4 Adjust the volume.

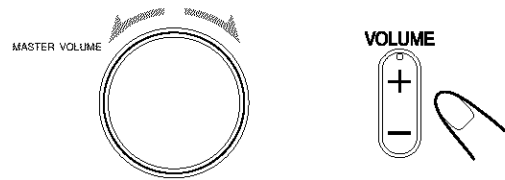

On the front panel

From the remote control

To activate and select Surround mode, see page 30.

About the indication on the display while playing back a disc

While you are playing back a disc, the playback information appears on the display as follows:

Ex.: When playing back a DVD VIDEO

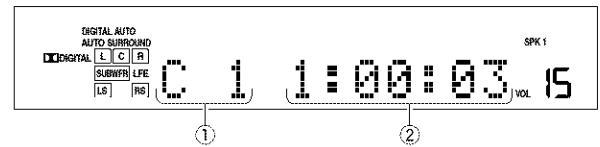

- Chapter number
- Elapsed playing time

Ex.: When playing back a DVD AUDIO*

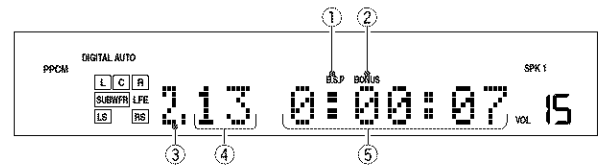

- B.S.P (Browsable Still Picture) indicator (lights up when you play back still pictures)
- BONUS indicator (lights up when the disc has a bonus group.)
- Group number
- Track number
- Elapsed playing time

Ex.: When playing back an audio CD

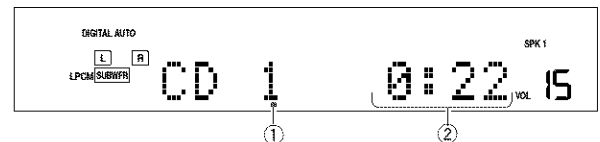

- Track number
- Elapsed playing time

* When a DVD AUDIO is loaded, the DVD AUDIO lamp lights up on the front panel.

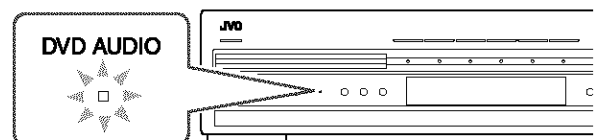

To stop playback

Press ■.

The unit memorizes the point where you stop playback and the RESUME indicator lights up on the display (except when an audio CD is loaded).

While the RESUME indicator is lit on the display, you can start playback from the memorized point by pressing ►—Resume play (see “About Resume play” on the right).

To remove the loaded disc

Press ▲ on the front panel or OPEN/CLOSE on the remote control.

The disc tray opens.

After removing the disc, press the button again to close the disc tray

- If you press ϕ /I STANDBY/ON on the front panel or ϕ /I AUDIO on the remote control while the disc tray is open, the disc tray closes automatically, then the unit is turned off.

■ Other operation buttons for the DVD player

On the front panel



From the remote control

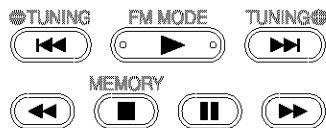

To stop playback temporarily

Press ■.

- Pressing ► starts playback again.

To move back the playback position by 10 seconds (for DVD VIDEO only)

Press ► during DVD VIDEO playback.

The unit moves the playback position about 10 seconds before the current position, then resumes playback.

To advance or reverse playback rapidly

- Press ►► or ◀◀ during playback. Each time you press ►► (or ◀◀), the unit advances (or reverses) playback, rapidly changing the playback speed as follows:

For DVD VIDEO:

x2 ⇒ x5 ⇒ x10 ⇒ x20 ⇒ x60

For DVD AUDIO/VCD/SVCD/CD:

x2 ⇒ x5 ⇒ x10 ⇒ x20

Pressing ► resumes the normal playback.

- Press and hold ►►► or ◀◀◀.

While you are pressing and holding ►►► (or ◀◀◀), the unit advances (or reverses) playback 5 times as fast as the normal speed. When you press and hold ►►► (or ◀◀◀) further, the playback speed changes up to 20 times as fast as the normal speed.

Releasing the button resumes the normal playback.

To locate the beginning of the chapter or track

Press ►►► or ◀◀◀.

Press ►►► (or ◀◀◀) to locate the beginning of the next (current or previous) chapter or track.

To locate the chapter or track using the number buttons

Press the number buttons (1 – 10, +10) to select the number of the desired chapter or track.

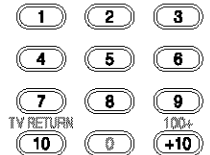

Ex.: To select 3, press 3.

To select 11, press +10, then 1.

To select 20, press +10, then 10.

About Resume play



This unit can memorize the point when you operate the following procedures:

- Pressing ■ during play—Pressing ► starts Resume play
- Changing the source—Pressing DVD or ► starts Resume play
- Turning off the unit (including Sleep Timer)—Pressing ► starts Resume play

Once you start Resume play, the RESUME indicator goes off (the unit clears the memorized point).

The unit also clears the memorized point when you operate the following procedures:

- Pressing ■ (while the RESUME indicator is lit on the display)
- Selecting a track by pressing ►►► or ◀◀◀ for video CD and super VCD when playback stops
- Selecting program or random playback
- Pressing TOP MENU
- Ejecting the loaded disc
- Turning on the unit by pressing ϕ /I STANDBY/ON on the front panel or ϕ /I AUDIO on the remote control
- Activating/deactivating Tray Lock.

You can cancel Resume play (see “Other setting menu—OTHERS” on page 56).

About Tray Lock

You can prevent the disc tray from opening unintentionally by using Tray Lock.

On the front panel ONLY

To lock the disc tray, press ▲ while pressing SETTING when the unit is in standby mode.

The unit is turned on and “LOCKED” appears on the display for a little while.

- If you try to open the disc tray, “LOCKED” appears to let you know that the Tray Lock is in use.

To unlock the disc tray, repeat the above procedure.

The unit is turned on and “UNLOCKED” appears briefly on the display.

The disc tray is unlocked.

Tuner Operations

Tuning in to Stations Manually

On the front panel

1 Press FM/AM to select the band.

The last received station of the selected band is tuned in. The CONTROL buttons now work for tuner operations.

- Each time you press the button, the band alternates between FM and AM.



Ex.: When selecting the FM band

2 Press CONTROL ▼ (or ▲) repeatedly until "< TUNING >" appears on the display.

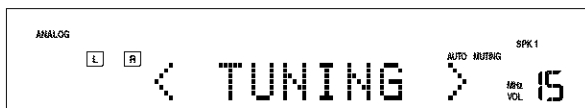

3 While "< TUNING >" remains on the display, press repeatedly or hold CONTROL ► (or ◀) until you find the frequency you want.



- Pressing (or holding) CONTROL ► increases the frequency.
- Pressing (or holding) CONTROL ◀ decreases the frequency.

From the remote control

1 Press FM/AM.

The last received station of the selected band is tuned in.

2 Press repeatedly or hold TUNING ⊕ or ⊖ until you find the frequency you want.

- Pressing (or holding) TUNING ⊕ increases the frequency.
- Pressing (or holding) TUNING ⊖ decreases the frequency.

Notes:

- When you hold and release CONTROL ► (or TUNING ⊕ on the remote control) or CONTROL ◀ (or TUNING ⊖ on the remote control), the frequency keeps changing until a specific station is tuned in.
- When a station of sufficient signal strength is tuned in, the TUNED indicator lights up on the display.
- When an FM stereo program is received, the STEREO indicator also lights up.

Using Preset Tuning

Once a station is assigned to a channel number, the station can be tuned in quickly. You can preset up to 30 FM and 15 AM stations.

Storing preset stations

Before you start, remember...

There is a time limit in doing the following steps.

If the setting is canceled before you finish, start from step 2 again.

On the front panel

1 Tune in to the station you want to store (see "Tuning in to Stations Manually").

- If you want to store the FM reception mode for this station, select the FM reception mode you want. See "Selecting the FM Reception Mode" on page 20.



Ex.: When selecting the FM band

2 Press MEMORY.

The channel number position flashes on the display for about 5 seconds.

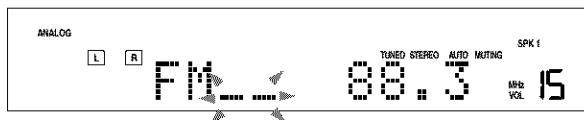

3 Press CONTROL ► (or ◀) to select a channel number while the channel number position is flashing.

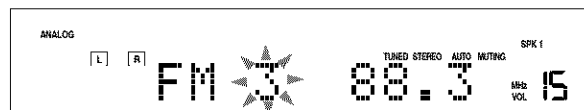

4 Press MEMORY again while the selected channel number is flashing on the display.

The station is assigned to the selected channel number.

- The selected channel number stops flashing and then the frequency flashes for about 5 seconds.

5 Press CONTROL ► (or ◀) to select another frequency you want to store while the frequency is flashing on the display.

6 Repeat steps 2 to 5 until you store all the stations you want.

To erase a stored preset station

Storing a new station on a used channel number erases the previously stored one.

From the remote control

After tuning in to the station you want to store,

- 1 Press MEMORY.
The channel number position flashes on the display for about 5 seconds.
- 2 Press the number buttons to select a preset channel number while the channel number position is flashing.
 - For channel number 5, press 5.
 - For channel number 15, press +10 then 5.
 - For channel number 30, press +10, +10, then 10.
- 3 Press MEMORY again.
- 4 Press TUNING \oplus or \ominus to select another frequency you want to store.
- 5 Repeat steps 1 to 4 until you store all the stations you want.

■ Tuning in to a preset station

On the front panel

1 Press FM/AM to select the band.

The last received station of the selected band is tuned in. The CONTROL buttons now work for tuner operations.



Ex.: When selecting the FM band

2 Press CONTROL \blacktriangledown (or \blacktriangle) repeatedly until "< PRESET >" appears on the display.



3 While "< PRESET >" remains on the display, press CONTROL \blacktriangleright (or \blacktriangleleft) to select a preset channel number you want.

- Pressing (or holding) CONTROL \blacktriangleright increases the preset channel numbers.
- Pressing (or holding) CONTROL \blacktriangleleft decreases the preset channel numbers.

From the remote control

- 1 Press FM/AM.
The last received station of the selected band is tuned in.
The number buttons now work for tuner operations.
- 2 Press the number buttons to select a preset channel number.
 - For channel number 5, press 5.
 - For channel number 15, press +10 then 5.
 - For channel number 30, press +10, +10, then 10.

Selecting the FM Reception Mode

When an FM stereo broadcast is hard to receive or noisy, you can change the FM reception mode while receiving an FM broadcast.

- You can store the FM reception mode for each preset station.

Before you start, remember...

There is a time limit in doing the following steps. If the setting is canceled before you finish, start from step 1 again.

On the front panel

1 While listening to an FM station, press CONTROL \blacktriangledown (or \blacktriangle) repeatedly until "< FM MODE >" appears on the display.



2 While "< FM MODE >" remains on the display, press CONTROL \blacktriangleright (or \blacktriangleleft) to select "MONO."

- Each time you press the button, FM reception mode alternates between "AUTO MUTING" and "MONO."

AUTO MUTING Normally select this (initial setting). When a program is broadcasted in stereo, you will hear stereo sound; when in monaural, you will hear monaural sounds. This mode is also useful to suppress static noise between stations. The AUTO MUTING indicator lights up on the display.

MONO Select to improve the reception (but stereo effect will be lost). In this mode, you will hear noise while tuning in to the stations. The AUTO MUTING indicator goes off from the display. (The STEREO indicator also goes off.)

To restore the stereo effect

Repeat step 1, then select "AUTO MUTING" in step 2.

From the remote control

- 1 Press FM/AM to select an FM station.
- 2 Press FM MODE.
 - Each time you press the button, FM reception mode alternates between "AUTO MUTING" and "MONO."

Basic Settings

Some of the following settings are required after connecting and positioning your speakers while others will make operations easier.

■ Quick speaker setup (see below)

■ Basic item setup (see pages 22 to 25)

- Speaker settings
 - Speaker information for subwoofer, front, center, and surround speakers*
 - Speaker distance for front, center, and surround speakers*
 - Crossover frequency*
 - Low frequency effect attenuator*
 - Dynamic range compression*
- Digital input (DIGITAL IN) terminals
- Auto surround
- Video output mode

* You can also set these items using the Choice menu (see pages 51 to 59).

Setting Speakers Quickly

You can register the speaker size and distance easily for the connected speakers (Quick Setup).

- To set the speaker size and distance manually, see "Speaker information" and "Speaker distance" on page 23.

On the front panel ONLY

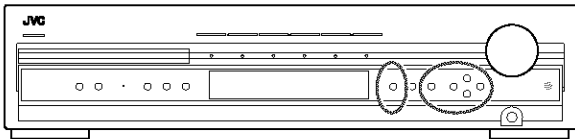

Before you start, remember...

There is a time limit in doing the following steps. If the setting is canceled before you finish, start from step 1 again.

1 Press SETTING.

The CONTROL buttons now work for basic settings. The setting item selected previously appears on the display. For the configuration of the basic setting items, see "Configuration of the items on the display" on page 22.

2 Press CONTROL ▼ (or ▲) repeatedly until "QUICK SETUP" appears on the display.



3 Press MEMORY.

"ENTER THE NUMBER OF SPEAKERS" scrolls on the display, then "5 SPEAKERS" appears.

4 Press CONTROL ► (or ◀) to select an appropriate number of the connected speakers.

- Each time you press the button, the indication changes as follows:

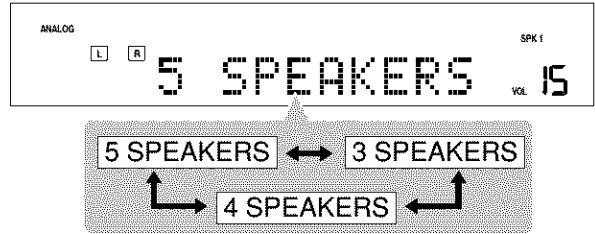

5 SPEAKERS Select when the front, center, and surround speakers are connected (initial setting).

4 SPEAKERS Select when the front and surround speakers are connected.

3 SPEAKERS Select when the front and center speakers are connected.

5 Press MEMORY.

"ENTER USE OF SUBWOOFER" scrolls on the display, then "SUBWFR USE" appears.

6 Press CONTROL ► (or ◀) to select whether you have connected a subwoofer or not.

- Each time you press the button, the indication changes as follows:

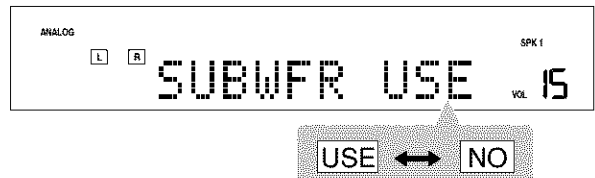

USE Select when a subwoofer is connected (initial setting).

NO Select when no subwoofer is used.

7 Press MEMORY.

"ENTER ROOM SIZE" scrolls on the display, then "SMALL ROOM" appears.

8 Press CONTROL ► (or ◀) to select an appropriate room size to match your listening room.

- Each time you press the button, the indication changes as follows:

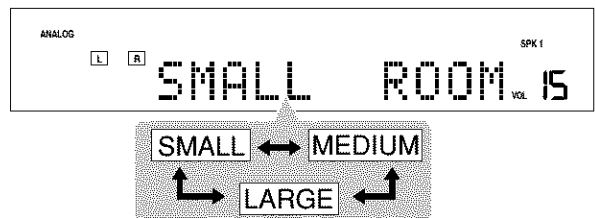

Select an appropriate room size according to the distance from your listening point to the speakers. See "Speaker distance for each room size" on page 22.

9 Press MEMORY to finish the setting.

"SETUP END" appears on the display for a while, then goes back to the source indication.

- Speaker configuration settings now become active. For the registered speaker size and distance, see below.

Note:

- This procedure will not be completed if you stop in the middle of the process.

Speaker size for each speaker channel number

Selected value		Speaker size		
Number of speakers	Subwoofer use	Front L/R (L/R)	Center (C)	Surround L/R (LS/RS)
3	NO	LRG	SML	NO
3	USE	SML	SML	NO
4	NO	LRG	NO	SML
4	USE	SML	NO	SML
5	NO	LRG	SML	SML
5	USE	SML	SML	SML

- For details about speaker size, see page 23.

Speaker distance for each room size

- When you select "SMALL" as the room size

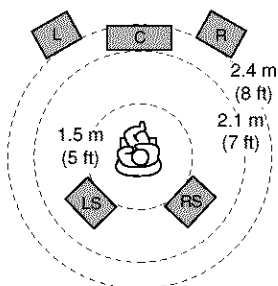

Front (L, R)	8 ft (2.4 m)
Center	7 ft (2.1 m)
Surround (LS, RS)	5 ft (1.5 m)

- When you select "MEDIUM" as the room size

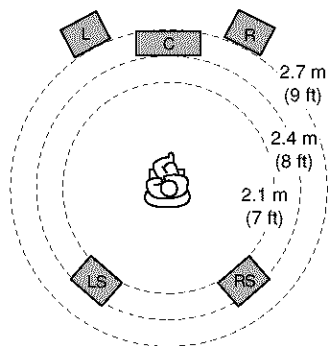

Front (L, R)	9 ft (2.7 m)
Center	8 ft (2.4 m)
Surround (LS, RS)	7 ft (2.1 m)

- When you select "LARGE" as the room size

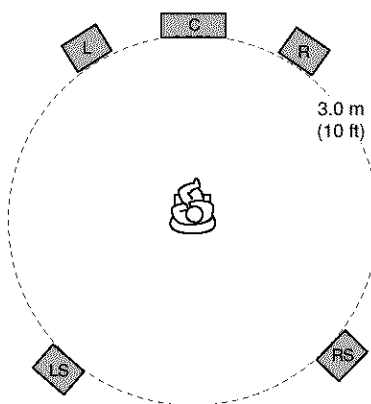

Front (L, R)	10 ft (3.0 m)
Center	10 ft (3.0 m)
Surround (LS, RS)	10 ft (3.0 m)

Setting Basic Items

After completing connection, set the basic items listed on page 21.

Operation buttons

On the front panel ONLY



Button	To do
SETTING	Show the setting items on the display*1.
CONTROL ▲/▼	Select an item on the display. Each time you press the button, the items change (see "Configuration of the items on the display" below).
CONTROL ►/◀	Adjust the selected item.

- When no operation is done for about 5 seconds, the indications on the display will disappear.

*1 Pressing SETTING repeatedly also changes the items.

Configuration of the items on the display

SUBWFR (Subwoofer)	↔ FRNT SP (Front speaker)	↔ CNTR SP (Center speaker)	↔
SURR SP (Surround speaker)	↔ FRNT D (Front distance)	↔ CNTR D (Center distance)	↔
SURR D (Surround distance)	↔ CROSS (Crossover)	↔ LFE (Low frequency effect)	↔
D.COMP (Dynamic range compression)	↔ DGT (Digital)	↔ AUTO SR (Auto surround)	↔
QUICK SETUP*2 (Quick setup)	↔ VOUT (Video out)	↔ (back to the beginning)	

*2 For details about "QUICK SETUP," see "Setting Speakers Quickly" on page 21.

Basic Settings

■ Operating procedure

Ex.: When setting the digital input (DIGITAL IN) terminals.

Before you start, remember...

There is a time limit in doing the following steps.

If the setting is canceled before you finish, start from step 1 again.

1 Press SETTING.

The CONTROL buttons now work for basic settings. The setting item selected previously appears on the display.

2 Press CONTROL ▼ (or ▲) repeatedly until “DGT (Digital)” (with the current setting) appears on the display.



3 Press CONTROL ► (or ◀) to select the appropriate digital terminal setting.

- Each time you press the button, the indication changes as follows:

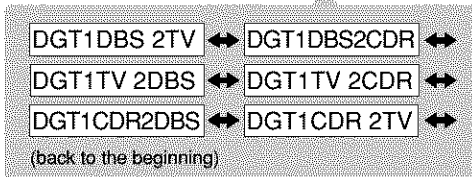

4 Repeat steps 2 and 3 to set other items if necessary.

- For details about each item, see below.

■ Speaker information

To obtain the best possible effect from the Surround modes (see pages 28 to 31), register the following information after all connections are completed.

- If you have used Quick Setup (see page 21), this setting is not required.

● For subwoofer—“SUBWFR”



Select one of the following settings:

- | | |
|-----|---|
| YES | Select when a subwoofer is connected. |
| NO | Select when no subwoofer is used (initial setting). |

Note:

- If you have selected “NO” for the subwoofer, you can only select “LRG (large)” for the front speakers.

● For front speakers—“FRNT SP”

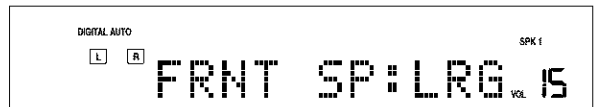

● For center speaker—“CNTR SP”



● For surround speakers—“SURR SP”

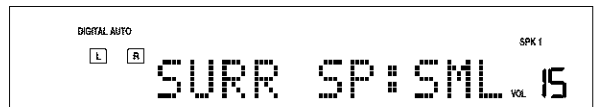

Select one of the following settings for each speaker:

- | | |
|-------------|---|
| LRG (large) | Select when the size of the cone speaker unit built in your speaker is greater than 12 cm (4 3/4 inches). |
| SML (small) | Select when the size of the cone speaker unit built in your speaker is smaller than 12 cm (4 3/4 inches). |
| NO | Select when you have not connected a speaker (not selectable for the front speakers). |

Notes:

- “LRG (large)” is the initial setting for the front speakers and “SML (small)” for the center and surround speakers.
- If you have selected “SML (small)” for the front speakers, you cannot select “LRG (large)” for the center and surround speakers.

■ Speaker distance

● For front distance—“FRNT D”

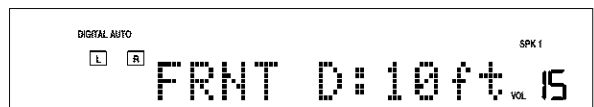

● For center distance—“CNTR D”



● For surround distance—“SURR D”



The distance from your listening point to the speakers is another important element to obtain the best possible surround sound from the Surround modes. Set the distance from your listening point to the speakers. By referring to the speaker distance setting, this unit automatically sets the delay time of the sound through each speaker so that sounds through all the speakers can reach you at the same time.

- If you have used Quick Setup (see page 21), this setting is not required.

Set the distance from the listening point within the range of 0.3 m (1 ft) to 9.0 m (30 ft), in 0.3 m (1 ft) intervals.

Notes:

- "10ft" is the initial setting.
- If you have selected "NO" for the center and surround speakers setting, you cannot set the speaker distance for the center and surround speakers.

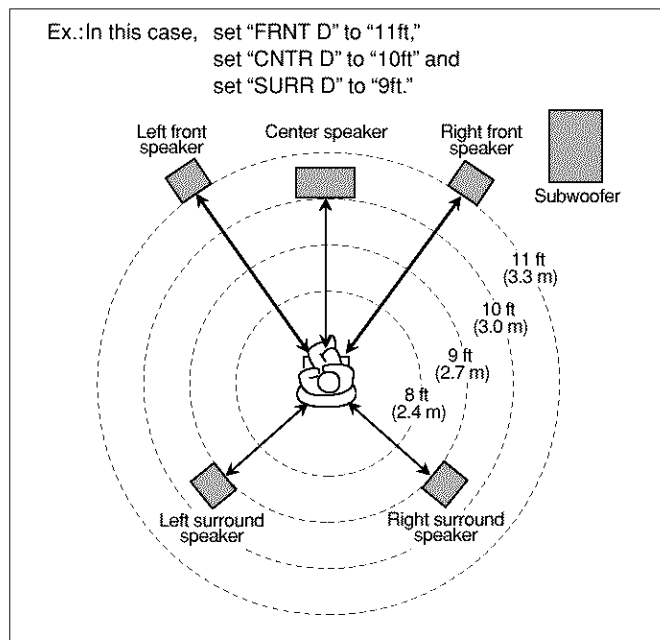

■ Crossover frequency

"CROSS"

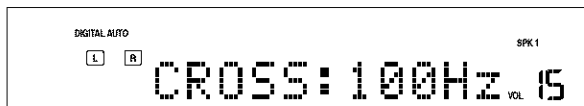

Small speakers cannot reproduce the bass sounds efficiently. If you use a small speaker in any position, this unit automatically reallocates the bass sound elements assigned to the small speaker to the large speakers.

To use this function properly, set the crossover frequency level according to the size of the small speaker connected.

- If you have selected "LRG (large)" for all speakers, this function will not take effect.

Select one of the following settings:

80Hz	Select when the cone speaker unit built in the speaker is about 12 cm (4 3/4 inches).
100Hz	Select when the cone speaker unit built in the speaker is about 10 cm (3 15/16 inches) (initial setting).
120Hz	Select when the cone speaker unit built in the speaker is about 8 cm (3 3/16 inches).

Note:

- Crossover frequency is not valid for the HEADPHONE mode.

■ Low frequency effect attenuator

"LFE"

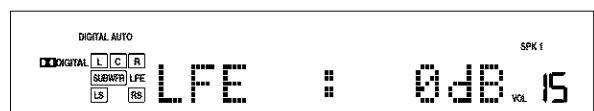

If the bass sound is distorted while playing back software encoded with Dolby Digital or DTS, set the LFE level to eliminate distortion.

- This function takes effect only when LFE signals come in.

Select one of the following settings:

0dB	Normally select this (initial setting).
-10dB	Select when the bass sound is distorted.

■ Dynamic range compression

"D.COMP"



You can compress the dynamic range (difference between maximum sound and minimum sound) of the reproduced sound. This is useful when enjoying surround sound at night.

- This function takes effect only when playing back a source encoded with Dolby Digital.

Select one of the following settings:

MID	Select when you want to reduce the dynamic range a little (initial setting).
MAX	Select when you want to apply the compression effect fully. (Useful at night.)
OFF	Select when you want to enjoy surround with its full dynamic range. (No effect applied.)

Basic Settings

■ Digital input (DIGITAL IN) terminals

“DGT”



When you use the digital input terminals, register what components are connected to which terminals (DIGITAL IN 1/ DIGITAL IN 2), so that the correct source name will appear when you select the digital source.

Set the appropriate digital terminal settings.

- Each time you press CONTROL ► or ◀, the settings change as follows:

1 DBS 2TV ⇄ 1 DBS 2 CDR ⇄ 1 TV 2 DBS ⇄
1 TV 2 CDR ⇄ 1 CDR 2 DBS ⇄ 1 CDR 2 TV ⇄
(back to the beginning)

Notes:

- “1DBS 2TV” is the initial setting.
- If you want to connect a CD recorder to the digital input terminal, change the source name from “TAPE” to “CDR.”
For details, see “Changing the Source Name” on page 13.

■ Auto surround

“AUTO SR”

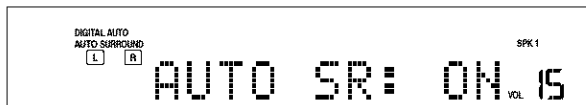

Surround mode is automatically activated when a digital multi-channel source such as Dolby Digital or DTS software or 2-channel matrix source such as Dolby Surround is played back.

You can enjoy Surround mode simply by selecting the source (with digital input selected for that source)—Auto Surround.

Select one of the following settings:

- ON** The AUTO SURROUND indicator always lights up on the display (initial setting).
- If multi-channel signals come in, an appropriate Surround mode will be turned on.
 - If Dolby Digital 2-channel or DTS 2-channel including surround signals come in, “PL II MOVIE” will be selected.
 - If Dolby Digital 2-channel or DTS 2-channel signals without surround signals come in, “STEREO” will be selected.
 - If the other signals come in, nothing will change.
- OFF** Select to deactivate Auto Surround.

Notes:

- This function does not take effect in the following cases:
 - While playing an analog source.
 - While selecting “DGTL D.D.” or “DGTL DTS” as the fixed digital input mode (see page 15).
- If you press SURROUND ON/OFF with Auto Surround activated, Auto Surround will be canceled temporarily for the currently selected source.
Auto Surround setting will be restored in the following cases:
 - When you turn off and on the unit,
 - When you change the source,
 - When you change the analog/digital input, and
 - When you reset “AUTO SR” to “ON” again.

■ Video output mode

“VOUT”



After connecting your TV to the unit, register the type of the connected video output terminal.

Without setting this, AV COMPU LINK does not work appropriately when “DVD” is selected as the source (see “AV COMPU LINK Remote Control System” on pages 61 and 62).

Set the output terminal appropriately:

VIDEO	Select when you connect your TV to the VIDEO jack by using a composite video cord (initial setting).
S	Select when you connect your TV to the S-VIDEO jack by using an S-video cord.
COMPNT	Select when you connect your TV to the DVD COMPONENT VIDEO OUT jacks by using a component video cord.

Sound Adjustments

You can make sound adjustments to your preference after completing basic setting.

Adjustment items:

- Front speaker output balance*¹
- Tone*¹
- Speaker output levels*¹
- DAP effect level
- Subwoofer audio position

*¹ You can also make these adjustments using the Choice menu (see pages 51 to 56).

Note:

- Adjustments you made are memorized separately for each source.

Operation buttons

On the front panel ONLY*²

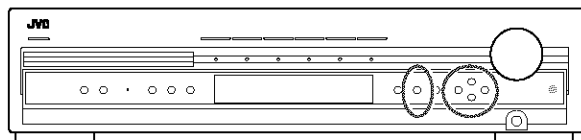

Button	To do
ADJUST	Show the adjustable items on the display* ³ .
CONTROL ▲/▼	Select an item on the display. Each time you press the button, the adjustable items change (see "Configuration of the items on the display" below).
CONTROL ►/◀	Adjust the selected item.

- When no operation is done for about 5 seconds, the indications on the display will disappear.
- *² You can also make sound adjustment except for front speakers' output balance from the remote control.
- *³ Pressing ADJUST repeatedly also changes the items.

Configuration of the items on the display

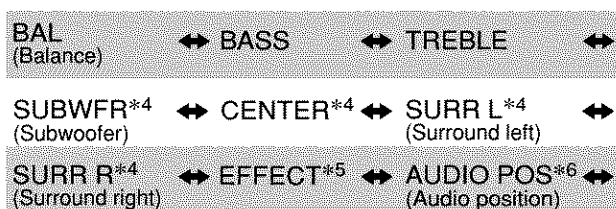

(back to the beginning)

- *⁴ These items appear only when the corresponding speakers are set to other than "NONE" as its speaker size.
- *⁵ "EFFECT" appears only when one of DAP modes (see pages 28 and 29) is activated.
- *⁶ "AUDIO POS" appears only when "YES" or "USE" (see pages 23 or 55) is selected for the subwoofer.

Operating procedure

Ex.: When setting the front speaker output balance.

Before you start, remember...

There is a time limit in doing the following steps. If the setting is canceled before you finish, start from step 1 again.

1 Press ADJUST.

The CONTROL buttons now work for sound adjustments. The setting item selected previously appears on the display.

2 Press CONTROL ▼ (or ▲) repeatedly until "BAL (Balance)" (with the current setting) appears on the display.



3 Press CONTROL ► (or ◀) to adjust the front speaker balance.

- Each time you press the button, the indication changes as follows:

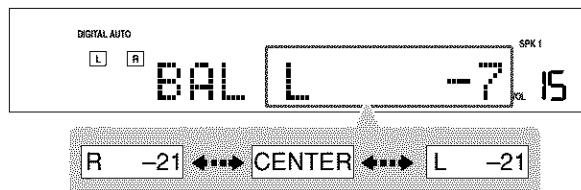

4 Repeat steps 2 and 3 to set other items if necessary.

For details about each item, see below.

Front speaker output balance

"BAL (balance)"



If the sounds you hear from the front right and left speakers are unequal, you can adjust the speaker output balance.

Adjust the output balance appropriately from the listening point within the range of R (Right) -21 to CENTER (0) or CENTER (0) to L (Left) -21 ("CENTER" is the initial setting).

Note:

- When you select "R -21," no sound comes out of the front right speaker, and when you select "L -21," no sound comes out of the front left speaker.

■ Tone

● For bass sound—"BASS"

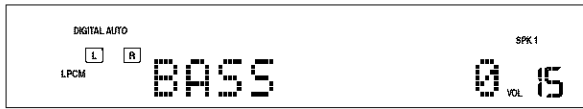

● For treble sound—"TREBLE"



You can adjust the bass and treble sounds as you like.

Adjust the tone within a range of -10 dB to +10 dB in 2 step intervals ("0" is the initial setting).

■ Speaker output levels

● For subwoofer—"SUBWFR"



● For center speaker—"CENTER"



● For left surround speaker—"SURR L"

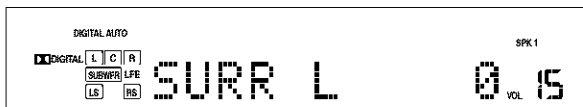

● For right surround speaker—"SURR R"

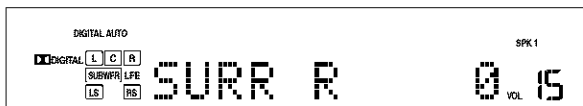

You can adjust the speaker output levels for the activated speakers.

- You can adjust the output level for center and/or surround speakers only when one of the proper Surround modes is activated (see "Relation between Surround modes and adjustable items" on page 31).

Adjust the speaker output level within a range of -10 dB to +10 dB in 1 step intervals ("0" is the initial setting).

■ DAP effect level

"EFFECT"



While one of the DAP modes is activated (the DSP indicator lights up on the display), you can adjust the effect level. For details about DAP modes, see pages 28 and 29.

Adjust the effect level within a range of 1 to 5 ("3" is the initial setting).

■ Subwoofer audio position

"AUDIO POS (position)"

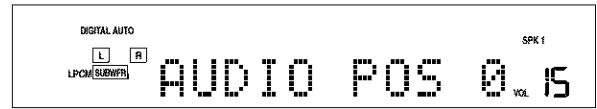

You may feel subwoofer is reinforced when listening stereo sound.

In this case, you can automatically change the subwoofer level properly when listening stereo sound.

- To adjust the subwoofer level, see the left column.

Select the automatic adjustment level from "0" to "-6" (in 2 step intervals).

If no adjustment is required, select "0" (initial setting). The smaller the number becomes, the more the level decreases automatically when listening in stereo.

- The A.POSITION indicator lights up when "AUDIO POS" is set to other than "0."

Note:

- You cannot adjust "AUDIO POS" when "NO" or "NONE" (see pages 23 or 55) is selected for the subwoofer.

Adjusting sound from the remote control

- To adjust bass sound, press BASS + or -.
- To adjust treble sound, press TREBLE + or -.
- To adjust subwoofer, press SUBWFR + or -.
- To adjust center speaker, press CENTER + or -.
- To adjust left surround speaker, press SURR L + or -.
- To adjust right surround speaker, press SURR R + or -.
- To adjust the effect level (for DAP mode), press EFFECT.
- To adjust subwoofer audio position, press AUDIO POSITION.

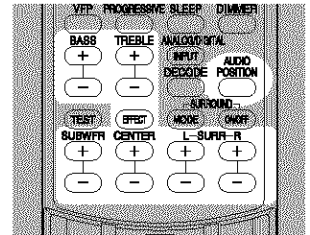

About auto memory

This unit memorizes the settings for each source:

- when you turn off the power (see page 12),
- when you change the source (see page 12),
- when you change the source name (see page 13), and
- when you change the analog/digital input mode (see page 14).

When you change the source, the memorized settings for the newly selected source are automatically recalled.

The following can be stored for each source:

- Analog/digital input mode (see page 14)
- Input attenuator mode (see page 15)
- Front speaker output balance (see page 26)
- Speaker output level (see the left column)
- Tone adjustment (see the left column)
- DAP effect level (see the left column)
- Surround mode selection (see page 30)

Note:

- If the source is FM or AM, you can assign a different setting for each band.

Creating Realistic Sound Fields

You can use the following Surround modes to reproduce a realistic sound field:

- Dolby surround
 - Dolby Pro Logic II
- Digital multi-channel surround
 - Dolby Digital
 - DTS Digital Surround
- DAP (Digital Acoustic Processor) modes
- All Channel Stereo

■ Dolby surround

Dolby Pro Logic II*

Dolby Pro Logic II is a playback format to decode into 5.1-channel from all 2-channel sources—stereo sources and Dolby surround encoded sources.

Matrix-based encoding/decoding method for Dolby Pro Logic II makes no limitation for the cutoff frequency of the surround treble and enables stereo surround sound compared to conventional Dolby Pro Logic.

- **You cannot select Dolby Pro Logic II when playing back DVD AUDIO.**

Dolby Pro Logic II enables you to reproduce spacious sound from original sound without adding any new sounds and tonal colorations.

Dolby Pro Logic II has two modes—Movie mode and Music mode:

Pro Logic II Movie (PL II MOVIE)—suitable for reproduction of Dolby Surround encoded sources bearing the mark

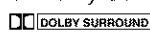
 and stereo television sources. You can enjoy a sound field very close to the one created with discrete 5.1-channel sounds.

Pro Logic II Music (PL II MUSIC)—suitable for reproduction of any 2-channel stereo music sources. You can enjoy wide and deep sound by using this mode.

- When Dolby Pro Logic II is activated, the  indicator lights up on the display.

■ Digital multi-channel (5.1 channel) surround

Dolby Digital*

Used to reproduce multi-channel sound tracks of the software encoded with Dolby Digital ().

- To enjoy the software encoded with Dolby Digital, connect the source component using the digital terminal on the rear of this unit. (See page 11.)

Dolby Digital 5.1-channel encoding method (so-called discrete multi-channel digital audio format) records and digitally compresses the left front channel, right front channel, center channel, left surround channel, right surround channel, and LFE channel signals.

Since each channel is completely independent from the other channel signals to avoid interference, you can obtain much better sound quality with many stereo and surround effects.

DTS Digital Surround**

Used to reproduce multi-channel sound tracks of software encoded with DTS Digital Surround (.

- To use software encoded with DTS Digital Surround, connect the source component using the digital terminal on the rear of this unit. (See page 11.)

DTS Digital Surround is another discrete multi-channel digital audio format available on CD, LD, and DVD software. Compared to Dolby Digital, audio compression ratio is relatively low. This fact allows DTS Digital Surround format to add breadth and depth to the reproduced sounds. As a result, DTS Digital Surround features natural, solid and clear sound.

Note:

- *Dolby Digital or DTS software can be roughly grouped into two categories—multi-channel (up to 5.1-channel) and 2-channel software. To enjoy surround sounds while playing Dolby Digital 2-channel or DTS software, you can use Dolby Pro Logic II.*

Typical multi-channel (5.1-channel) reproduction

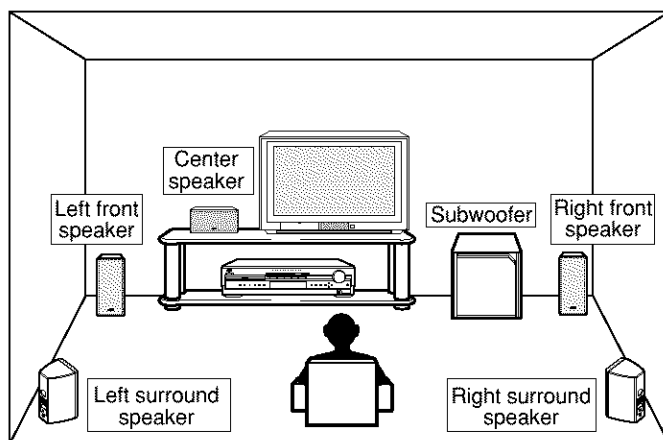

■ DAP (Digital Acoustic Processor) modes

DAP modes have been designed to create important acoustic surround elements.

- **You cannot select DAP modes when playing back DVD AUDIO.**

The sound heard in a live club, dance club, hall or pavilion consists of direct sound and indirect sound—early reflections and reflections from behind. Direct sounds reach the listener directly without any reflection. On the other hand, indirect sounds are delayed by the distances of the ceiling and walls (see the diagram on the next page).

These indirect sounds are important elements of the acoustic surround effects. The DAP mode can reproduce a realistic sound field by adding these indirect sounds.

* Manufactured under license from Dolby Laboratories. "Dolby", "Pro Logic", and the double-D symbol are trademarks of Dolby Laboratories.

** "DTS" and "DTS Digital Surround" are registered trademarks of Digital Theater Systems, Inc.

Creating Realistic Sound Fields

DAP modes can be used when the front and surround speakers are connected to this unit (without respect to the center speaker connection: no sound comes out of the center speaker even if it is connected).

The following DAP modes are provided for this unit:

LIVE CLUB	Gives the feeling of a live music club with a low ceiling.
DANCE CLUB	Gives a throbbing bass beat.
HALL	Gives clear vocal and the feeling of a concert hall.
PAVILION	Gives the spacious feeling of a pavilion with a high ceiling.

These DAP modes can be used to add the acoustic surround effects while reproducing 2-channel stereo software, either analog or Linear PCM digital signal, and can give you a real "being there" feeling.

- When one of the DAP modes is selected, the DSP indicator lights up on the display.

Creating sound field

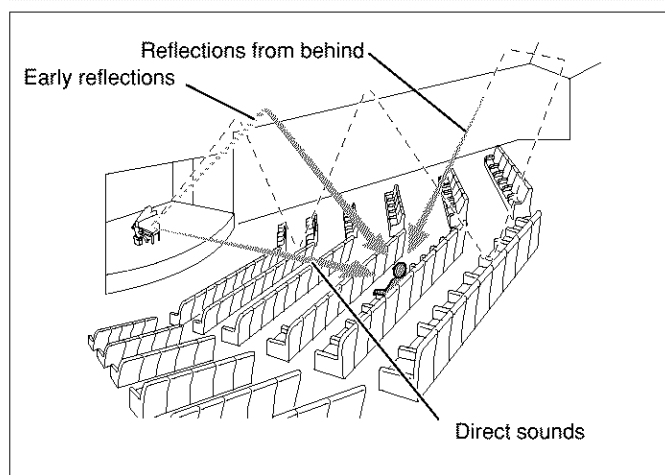

All Channel Stereo

This mode can reproduce a larger stereo sound field using all the connected (and activated) speakers.

- You cannot select All Channel Stereo when playing back DVD AUDIO.

All Channel Stereo can be used when the front and surround speakers are connected to this receiver without respect to the center speaker connection.

If the center speaker is connected and activated, the same phases of the front left and right signals are mixed and output through the center speaker.

All Channel Stereo can be used while reproducing 2-channel stereo software, either analog or Linear PCM digital signal.

- When All Channel Stereo is selected, the DSP indicator lights up on the display.

All Channel Stereo reproduction

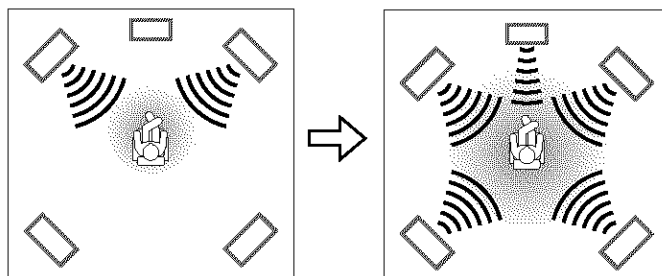

Sound reproduced from normal stereo

Sound reproduced from All Channel Stereo

Notes for DVD AUDIO multi-channel surround

- When playing back DVD AUDIO, you cannot select Pro Logic II, DAP modes, and All Channel Stereo.
- For the multi-channel track which can be mixed down: When "NO" is selected as the speaker setting for the center or surround speakers, the corresponding multi-channel is mixed down to the front speaker channels.
- For the multi-channel track which cannot be mixed down:
 - When you try to deactivate Surround mode during play, "MULTI CH" appears on the display and Surround mode still remains.
 - When you start playback with Surround mode deactivated, "LR ONLY" appears on the display. In this case, you cannot listen to the sounds other than left and right front channels.

Available Surround modes for each input signal

○: Possible ×: Impossible

Modes Signals	STEREO	DOLBY DIGITAL	DTS SURROUND	PLII MOVIE	PLII MUSIC	LIVE CLUB	DANCE CLUB	HALL	PAVILION	ALL CH ST.
Dolby Digital (Multi-channel)	○	○	×	×	×	×	×	×	×	×
Dolby Digital (2-channel)	○	×	×	○	○	×	×	×	×	×
Dolby Surround (matrix 2-ch)	○	×	×	○	○	×	×	×	×	×
DTS Digital Surround (Multi-channel)	○	×	○	×	×	×	×	×	×	×
DTS Digital Surround (2-channel)	○	×	×	○	○	×	×	×	×	×
Linear PCM	○	×	×	○	○	○	○	○	○	○
Analog	○	×	×	○	○	○	○	○	○	○

Activating Surround Mode

When Auto Surround is set to "OFF" or 2-channel source other than Dolby Surround software is played back, activate Surround mode manually.

Make sure that you have set the speakers' information correctly (see pages 23 or 55).

- If only front speakers are connected, you cannot activate any Surround mode.



On the front panel

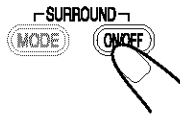

From the remote control

Press SURROUND ON/OFF.

The SURROUND indicator lights up on the display.

To cancel the Surround mode

Press SURROUND ON/OFF again.

- Surround mode is deactivated ("STEREO" appears on the display).

About SURROUND indicators

- When Auto Surround is set to "ON," the AUTO SURROUND indicator always lights up on the display.
- When you activate Surround mode manually with Auto Surround set to "OFF," the SURROUND indicator lights up on the display.

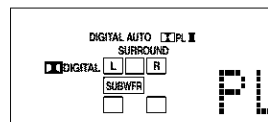
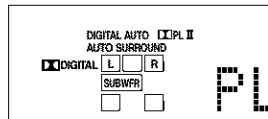

Selecting Surround Modes

When 2-channel source is played back with Surround mode activated, you can select another Surround mode. Available Surround modes will vary depending on the number of the connected speakers and the playback sound.

Make sure that you have set the speakers' information correctly (see pages 23 or 55).

- If surround speakers are not connected, you cannot use DAP modes and All Channel Stereo.
- If you select any of the Surround modes while using both the speakers connected to the FRONT SPEAKERS 1 and 2 terminals, the speakers connected to the FRONT SPEAKERS 2 terminals are deactivated.

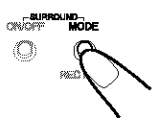

On the front panel



From the remote control

Press SURROUND MODE.

- Each time you press the button, Surround mode changes as illustrated below.

When 5 or 4 speakers (except center speaker) are connected:

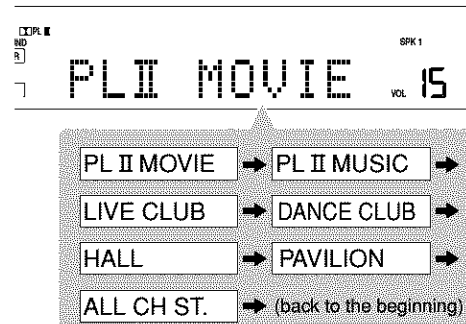

When 3 speakers (except surround speakers) are connected or Dolby Digital including matrix source is played back:

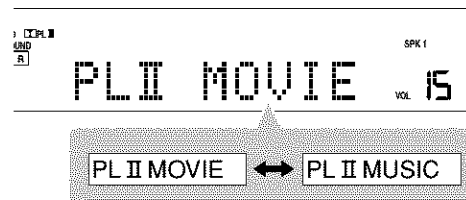

Signal and speaker indicators on the display

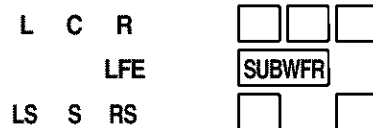

Signal indicators Speaker indicators

The following signal indicators light up—:

- L, R:
 - **When digital input is selected:** Light up when the signals corresponding to each channel come in.
 - **When analog input is selected:** Always light up.
- C, LS, RS: Light up when the signals corresponding to each channel come in.
- S: Lights up when the monaural surround channel signal comes in.
- LFE: Lights up when the LFE channel signal comes in.

The speaker indicators light up as follows:

- The subwoofer speaker indicator (SUBWFR) lights up when the subwoofer is set to "YES" (see page 23) or "USE" (see pages 21 or 55).
- The other speaker indicators light up only when the corresponding speaker is activated, and also when required for the current playback.

Creating Realistic Sound Fields

Adjusting Surround Mode Using Remote Control

When playing back the source with Surround mode, you can adjust the speaker output levels for Surround modes. Once you have adjusted the Surround modes, adjustment is memorized for each source.

- You can also adjust Surround modes using the Choice menu (see pages 54 and 55) or buttons on the front panel (see page 27).

1 Select and play back software you like.

2 Activate and select Surround mode.

- When 2-channel source is played back, you can select Surround modes.

3 Adjust the speaker output levels.

- To adjust center speaker, press CENTER +/-.*
- To adjust left surround speaker, press SURR L +/-.
- To adjust right surround speaker, press SURR R +/-.
- To adjust subwoofer, press SUBWFR +/-.
- To adjust the effect level, press EFFECT.**

The name for the item currently adjusted appears on the display.

Notes:

- You can adjust the speaker output levels for the activated speakers ONLY (the speaker indicators are lit on the display).
- * You cannot adjust the output level of the center speaker when one of the DAP modes is activated.
- ** You can adjust the effect level only when one of the DAP modes is activated.

For using test tone

1 Press TEST.

The playback sound stops during play. "TEST L" starts flashing on the display and a test tone comes out of the speakers in the following order:

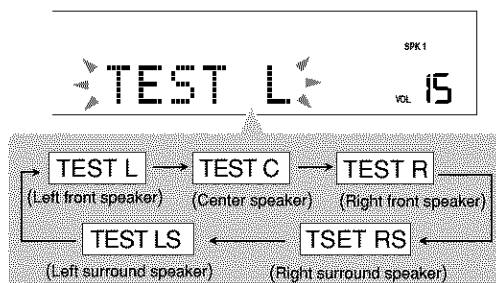

2 Adjust the speaker output level as follows:

- To adjust center speaker, press CENTER +/-.
- To adjust left surround speaker, press SURR L +/-.
- To adjust right surround speaker, press SURR R +/-.

Notes:

- You cannot adjust the speaker output levels if you have set the speaker information to "NO."
- No test tone comes out of a speaker when its speaker information is set to "NO."
- When you press EFFECT or SUBWFR +/-, the test tone stops.

3 Press TEST to stop the test tone.

The test tone stops.

- When no operation is done for about 1 minute, the test tone stops automatically.

Relation between Surround modes and adjustable items

○: Possible ×: Impossible

Mode \ Item	TEST	CENTER	SURR L	SURR R	SUBWOOFER	EFFECT
Dolby Digital	○	○	○	○	○	×
DTS Digital Surround	○	○	○	○	○	×
Dolby Pro Logic II	○	○	○	○	○	×
DAP	○	×	○	○	○	○
All Channel Stereo	○	○	○	○	○	×

Note:

- You cannot adjust the speakers which are not used by the selected Surround mode.

DVD Player Operations

Disc Information

Playable disc types

This unit has been designed to play back the following discs: DVD VIDEO, DVD AUDIO, Video CD (VCD)*, Super Video CD (SVCD)*, audio CD*, CD-R, and CD-RW.

* This instruction refers to Video CD as VCD, Super Video CD as SVCD, and audio CD as CD.

Disc Type	Mark (Logo)
DVD VIDEO	 
DVD AUDIO	 
VCD	 
SVCD	 
CD	
CD-R	
CD-RW	

- This unit can also play back MP3 and JPEG (still picture) files recorded on CD-R and CD-RW. For details about MP3, see "MP3 Disc Playback" on pages 47 and 48 and about JPEG, see "JPEG Disc Playback" on pages 49 and 50.

- The following discs cannot be played back:**

DVD-ROM, DVD-RAM, DVD-RW, CD-ROM, CD-I (CD-I Ready), Photo CD, etc.

Playing back these discs will generate noise and damage the speakers.

- On some DVD VIDEO, DVD AUDIO, VCD, or SVCD, their actual operations may be different from what is explained in this manual. This is due to the disc programming and disc structure, but not a malfunction of this unit.

- You can play back DVD-R recorded with the DVD VIDEO format, but some may not be played back because of the disc characteristics or recording conditions.

Note on Region Code

DVD players and DVD VIDEO have their own Region Code numbers. This unit can play back only DVD VIDEO recorded with the color system of NTSC whose Region Code numbers include "1."



If a DVD VIDEO with the wrong Region Code numbers is loaded, "REGION CODE ERROR!" appears on the TV and playback cannot start.

Notes on CD-R and CD-RW

- User-edited CD-R (Recordable) and CD-RW (ReWritable) can be played back only if they are already **"finalized."**
- The unit can play back CD-R or CD-RW recorded on a personal computer if they have been recorded in the audio CD format or in MP3 format. The unit can also play back CD-R or CD-RW if MP3 files or JPEG files are recorded on them. However, they may not be played back because of their disc characteristics, recording conditions, or damage or stain on them. Especially, the configuration and characteristics of an MP3 disc or a JPEG disc is determined by the writing (encoding) software and hardware used for recording. Therefore, due to the software and hardware used, the following symptoms may occur:
 - Some discs may not be played back.
 - Some tracks on an MP3 disc are skipped and may not be played back normally.
 - Some files on a JPEG disc may be played back distortedly.
- Before playing back CD-R or CD-RW, read their instructions or cautions carefully.
- CD-RW may require a longer readout time. It is caused by the fact that the reflectance of CD-RW is lower than for regular audio CD.

IMPORTANT: Before playing a disc, make sure of the following...

- Check the connection with the TV.
- Turn on the TV and select the correct input mode on the TV to view the pictures or on-screen indications on the TV screen.
- For disc playback, you can change the initial setting to your preference. (See pages 51 to 59.)

If "⊗" appears on the TV screen when you press a button, the disc cannot accept an operation you have tried to do, or data required for that operation is not recorded on the disc.

NOTICE: In some cases, without showing "⊗," operations will not be accepted.

DVD Player Operations

■ Disc structure

DVD VIDEO consists of "titles," and each title may be divided into some "chapters."

For example, if a DVD VIDEO contains some movies, each movie may have its own **title** number and it may be further divided into some **chapters**. In a DVD VIDEO Karaoke, each song may have its own **title** number, but it may not be further divided into **chapters**.

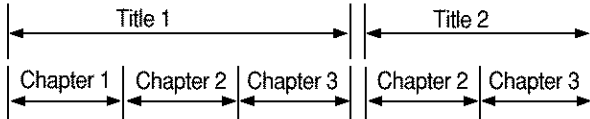

DVD AUDIO consists of "groups," and each group may be divided into some "tracks."

Some DVD AUDIOS also contain a "bonus group" that can be played back by entering the "key number" (a kind of password). Usually the contents of "bonus group" are not open to the public.

Note that most DVD AUDIOS include much information in addition to audio, such as still pictures, movies, and text.



VCD, SVCD, and CD consist of "tracks."

In general, each track has its own **track** number. (On some discs, each track may also be divided by indexes. This unit is not compatible with Index function.)

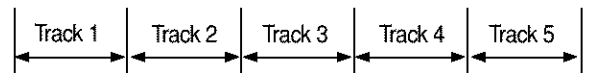

On an **MP3 disc**, each song is recorded as a file. Files are usually grouped into a folder. Folders can also include other folders, creating hierarchical folder layers.

This unit simplifies the hierarchical construction of a disc and manages files and folders by "tracks" and "groups."

- This unit can recognize and play back up to 150 tracks per group and up to 99 groups per disc (up to 14,850 tracks in total). Tracks whose numbers exceed 150 and groups whose numbers exceed 99 cannot be played back.

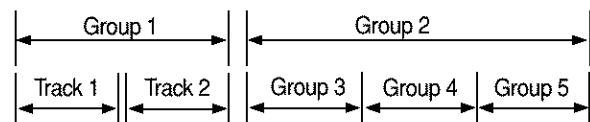

On a **JPEG disc**, each still picture is recorded as a file. Files are usually grouped into a folder. Folders can also include other folders, creating hierarchical folder layers.

This unit simplifies the hierarchical construction of a disc and manages folders by "groups."

- This unit can recognize and play back up to 150 files per group and up to 99 groups per disc (up to 14,850 files in total). Files whose numbers exceed 150 and groups whose numbers exceed 99 cannot be played back.

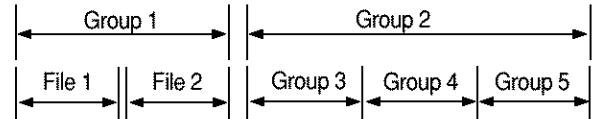

■ Playback Control function (PBC)—VCD and SVCD only

The Playback Control function enables menu-driven operation.

Menu-driven playback

A selection menu is displayed when you start playing a VCD and SVCD with the Playback Control feature. The selection menu shows a list of numbers for selection. Some discs may show moving pictures or a divided screen.

You can interact with the screen using a menu display to select and play an entry.

See the example illustration below about basic feature of menu-driven playback (for details about the operation through the menu, see also page 36).

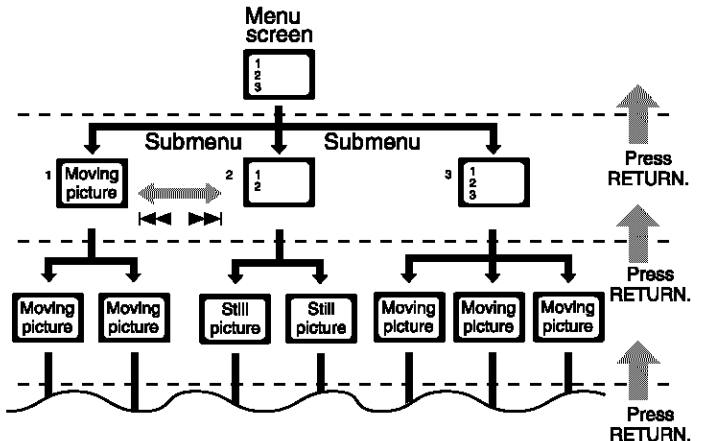

Note:

- While operating a VCD or SVCD using the menu, some of the functions such as repeat play may not work.

This section explains advanced operations of the built-in DVD player by using the remote control. For MP3 playback, see pages 47 and 48, and for JPEG playback, see pages 49 and 50.

- See also "Basic DVD Player Operations" on pages 17 and 18.
-  indicates types of disc available for the operation.
- Turn on your TV and select the correct input mode on the TV.

If "⊘" appears on the TV when you press a button, the disc cannot accept an operation you have tried to do, or data required for that operation is not recorded on the disc.

About the On-screen Bar

You can check the information on a disc while the disc is loaded and use some functions through the on-screen bar.

Before using the remote control, press DVD so that the remote control works for the DVD player.

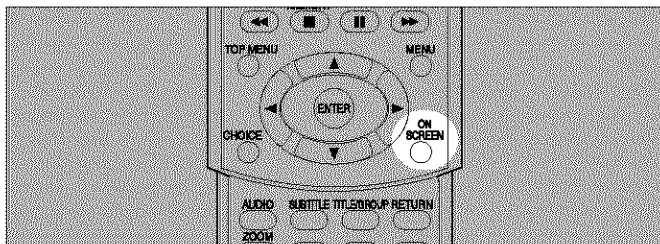

Whenever a disc is loaded

Press ON SCREEN.



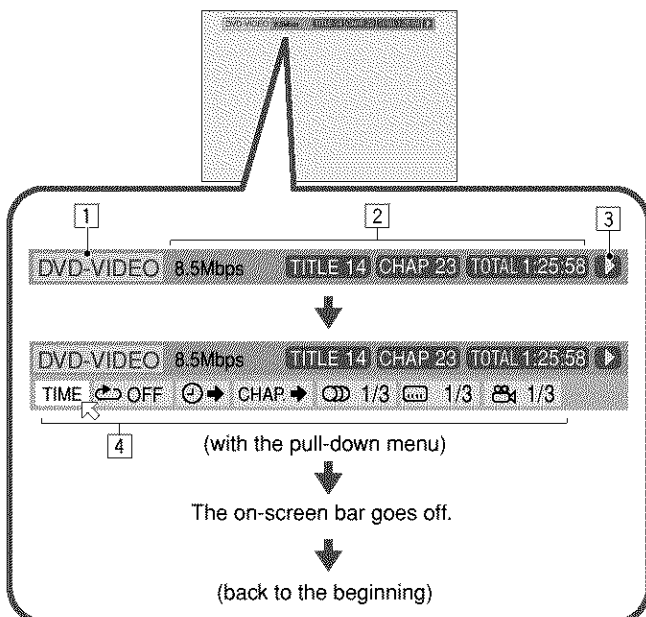

- Each time you press the button, the on-screen bar changes as follows:

Ex.: When a DVD VIDEO is played







- For the contents of the on-screen bar (1 to 4), see the right column.













- 1 Disc type
- 2 Playback information

Indication	Meanings	Available discs
Mbps	shows the current transfer rate (Megabits per second).	
TITLE 14	shows the current title.	
CHAP 23	shows the current chapter.	
GROUP	shows the current group.	
TRACK 14	shows the current track.	
TOTAL 1:25:58	shows the elapsed playing time.	all discs

- 3 Playback conditions for all types of disc

Indication	Meanings
	Playback
	Fast forward/Fast reverse
	Forward/reverse slow-motion
	Pause
	Stop

- 4 Operation icons (on the pull-down menu)

Indications	Meanings	Available discs
TIME	Select to change the time indication. See page 35.	all discs
	Select to repeat playback. See page 45.	all discs
	Select for time search. See page 40.	all discs
CHAP. →	Select for chapter search. See page 40.	
TRACK →	Select for track search. See page 40.	
	Select to change the audio language or channel. See page 38.	
	Select to change subtitle language. See page 37.	
	Select to change the view angle. See page 37.	
PAGE 1/15	Select to change the page. See page 41.	
PROG.	Select for program play. See page 44.	
RND.	Select for random play. See page 45.	

DVD Player Operations

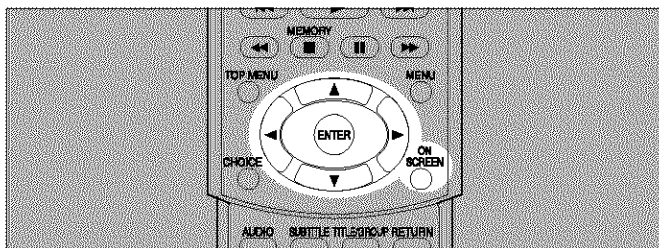

Basic Operation through the On-screen Bar

Ex.: When selecting the repeat mode for DVD VIDEO

- During playback or while stopped

1 Press ON SCREEN twice.

The on-screen bar with pull-down menu appears on the TV.



2 Press cursor ► (or ◀) repeatedly to move to TIME OFF on the pull-down menu.



3 Press ENTER.

The pop-up window appears under the pull-down menu.

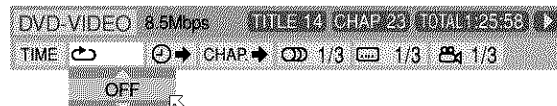

4 Press cursor ▼ (or ▲) to select the desired option in the pop-up window.

- Each time you press the button, the options change.

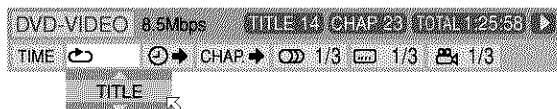

5 Press ENTER.

The setting changes and the pop-up window goes off.

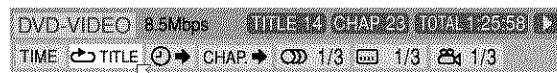

To turn off the on-screen bar

Press ON SCREEN.

Note:

- See the relevant pages for the detail of each function.

Changing the Time Indication

You can change the time information in the on-screen bar and the display window on the center unit.



- During playback or while stopped

1 Press ON SCREEN twice.

The on-screen bar appears on the TV.

2 Press cursor ► (or ◀) to move to TIME.

3 Press ENTER.

- Each time you press ENTER, the time indication in the on-screen bar changes as follows:

Ex.:

TOTAL 1:25:58 ⇒ T.REM 0:45:44 ⇒ TIME 0:25:58 ⇒
REM 0:18:14 ⇒ (back to the beginning)

TOTAL	Elapsed disc time
T. (total) REM	Remaining disc time
TIME	Elapsed playing time of the current chapter/track
REM	Remaining time of the current chapter/track

- The indication on the display also changes.

Note:

- While playing a VCD, SVCD, or CD, the indication of the hour digit does not appear.

To turn off the on-screen bar

Press ON SCREEN.

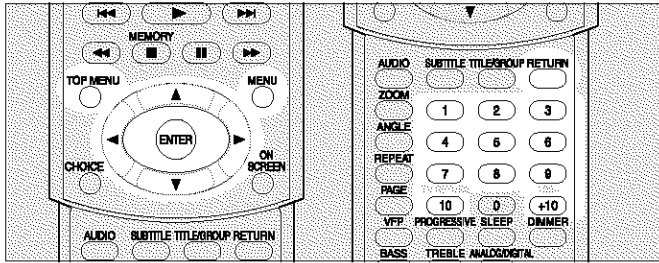

Locating a Desired Scene from the Disc Menu

Using the disc menu, you can start playing a title, chapter, or track you specify.

- Before using the remote control, press DVD so that the remote control works for the DVD player.
- If the on-screen bar is shown on the TV, press ON SCREEN repeatedly to go off the on-screen bar.

From the DVD menu

DVD VIDEO and DVD AUDIO generally have their own menus which show the disc contents. These menus contain various items such as titles of movies, names of songs, or artist information, and display them on the TV screen. You can locate a specific scene using these menus.



□ When a disc is loaded

1 Press TOP MENU or MENU.

The DVD menu appears on the TV. (The menu usually appears on the TV automatically after loading the disc.)

Ex.:

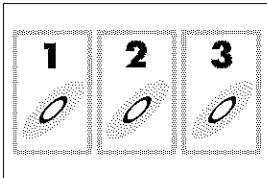

DVD VIDEO/DVD AUDIO normally has a "top" menu when it contains more than one title/group. In this case, press TOP MENU to show the title menu.

Some DVD VIDEO/DVD AUDIO may also have a different menu which is shown by pressing the MENU button. See the instructions of each DVD VIDEO/DVD AUDIO for its particular menu.

2 Use cursor ▲/▼/▶/◀ to select a desired item, then press ENTER.

The unit starts playback of the selected item.

- With some discs, you can also select items by entering the corresponding number using number buttons.

From the VCD/SVCD menu with PBC

VCD or SVCD recorded with PBC has its own menus such as a list of the tracks. (After loading such a disc, "PBC" appears on the display.) You can locate the specific track by using the menu (see also page 33).



□ When the menu appears on the TV during playback with PBC

Press number buttons (1–10, +10) to select the number of the desired item.

The unit starts playback from the selected item.

Ex.: To select 3, press 3.

To select 11, press +10, then 1.

Ex.:

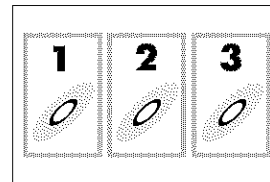

To return to the menu

Press RETURN.

When "NEXT" or "PREVIOUS" is shown on the TV screen

To go to the next page, press ▶▶.

To return to the previous page, press ◀◀.

To play back PBC-compatible VCD/SVCD without PBC

Start playback by pressing the number buttons while playback is stopped.

The elapsed playing time appears on the display instead of "PBC."

To restore PBC

Press TOP MENU or MENU.

"PBC" appears again on the display.

About the indication on the display while playing back a VCD/SVCD

While you are playing back a VCD/SVCD recorded with PBC, playback information appears on the display as follows:

Ex.: When a VCD is played back using PBC

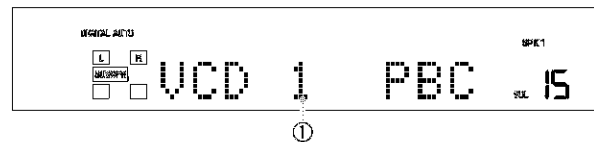

Ex.: When a VCD is played back without using PBC

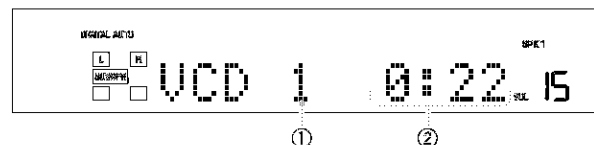

- ① Track number
- ② Elapsed playing time

DVD Player Operations

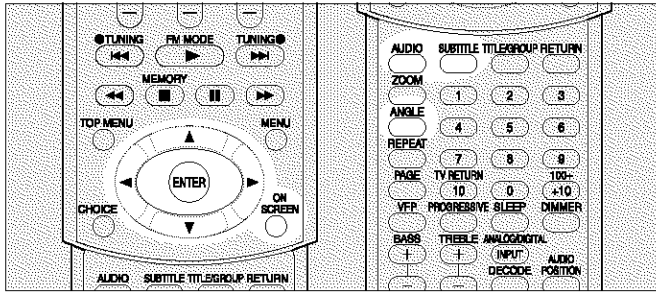

Selecting a View Angle

While playing back a DVD VIDEO/DVD AUDIO containing multi-view angles, you can view the same scene from different angles. The  icon appears at the beginning of playback when the current scene has multi-view angles.



1 Press ANGLE.

The following pop-up window appears on the TV.

Ex.: The first view angle is selected out of 3 view angles recorded.

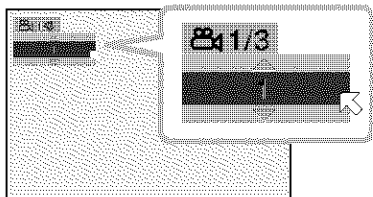

2 Press ANGLE repeatedly to select the desired view angle.

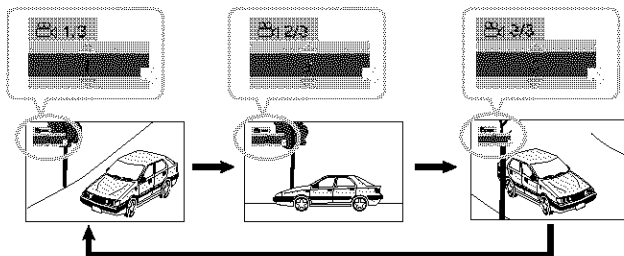

- Each time you press the button, the angle of the scene changes.

Ex.: 1/3 ⇒ 2/3 ⇒ 3/3 ⇒ (back to the beginning)



The pop-up window goes off if no operation is done for about 5 seconds.



Using the on-screen bar

- Press ON SCREEN repeatedly until the on-screen bar with pull-down menu appears on the TV.
- Press cursor  (or ) repeatedly to move to  in the pull-down menu, then press ENTER.

The following pop-up window appears under the pull-down menu.

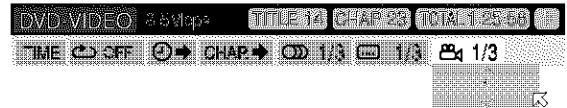
Ex.: The first view angle is selected out of 3 view angles recorded.



- Press cursor  (or ) repeatedly to select the desired view angle.
 - Each time you press the button, the angle of the scene changes.
- Press ENTER.
 - The pop-up window goes off.

To turn off the on-screen bar

Press ON SCREEN.

Selecting the Subtitle Language

While playing back a DVD VIDEO/DVD AUDIO/SVCD containing subtitles in different languages, you can select the subtitle language to be displayed on the TV. The  icon appears at the beginning of playback when the current scene has plural subtitles.



1 Press SUBTITLE.

The following pop-up window appears on the TV.

Ex.: "ENGLISH" is selected from the 3 subtitle languages recorded.

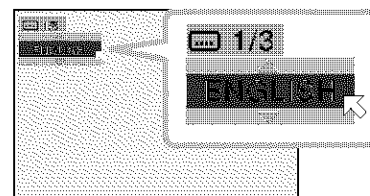



2 Press SUBTITLE repeatedly to select the desired subtitle language.

- Each time you press the button, the subtitle language changes.

The pop-up window goes off if no operation is done for about 5 seconds.

Using the on-screen bar

- 1 Press ON SCREEN repeatedly until the on-screen bar with pull-down menu appears on the TV.
- 2 Press cursor ► (or ◀) repeatedly to move  to  in the pull-down menu, then press ENTER.
The following pop-up window appears under the pull-down menu.

Ex.: "ENGLISH" is selected from the 3 subtitle languages recorded.



- 3 Press cursor ▼ (or ▲) repeatedly to select the desired subtitle language.
 - Each time you press the button, the subtitle language changes.
- 4 Press ENTER.
The pop-up window goes off.

To turn off the on-screen bar

Press ON SCREEN.

Notes:

- For DVD VIDEO/DVD AUDIO: Some subtitle languages are abbreviated in the pop-up window. See "Language code list" on page 54.
- For SVCD: SVCD can contain up to four subtitles. Pressing SUBTITLE changes the subtitles regardless of whether the subtitles are recorded or not. (Subtitles will not change if no subtitle is recorded.)
- If "Ⓞ" appears on the TV, the current scene does not contain plural subtitles.

Selecting the Audio Language

When DVD VIDEO/DVD AUDIO contains audio languages (sound track), you can select the language (sound track) to listen to.

The  icon appears at the beginning of playback when the current scene has plural audio languages.

- You can also select the audio channel(s) of VCD or SVCD.



During playback

1 Press AUDIO.

The following pop-up window appears on the TV.

Ex.: "ENGLISH" is selected from the 3 audio languages recorded.

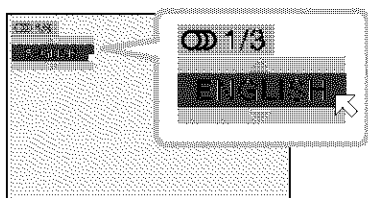



2 Press AUDIO repeatedly to select the desired audio language.

- Each time you press the button, the audio language changes.

The pop-up window goes off if no operation is done for about 5 seconds.

Using the on-screen bar

- 1 Press ON SCREEN repeatedly until the on-screen bar with pull-down menu appears on the TV.
- 2 Press cursor ► (or ◀) repeatedly to move  to  in the pull-down menu, then press ENTER.
The following pop-up window appears under the pull-down menu.

Ex.: "ENGLISH" is selected from the 3 audio languages recorded.



- 3 Press cursor ▼ (or ▲) repeatedly to select the desired audio language.
 - Each time you press the button, the audio language changes.
- 4 Press ENTER.
The pop-up window goes off.

To turn off the on-screen bar

Press ON SCREEN.

Notes:

- Some audio languages are abbreviated in the pop-up window. See "Language code list" on page 54.
- If "Ⓞ" appears on the TV, the current scene does not contain plural audio languages.

Selecting the Audio Channel

When playing back some Karaoke VCDs or SVCDs, you can enjoy Karaoke by selecting the audio channel to play.



During playback

1 Press AUDIO.

The following pop-up window appears on the TV.

Ex.: "ST" (stereo) is selected.

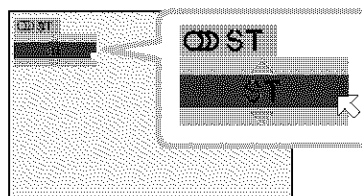

TO BE CONTINUED TO THE NEXT PAGE

2 Press AUDIO repeatedly to select the desired audio channel.

- Each time you press the button, the audio channel changes.

For VCD:

Ex.: ST ⇒ L ⇒ R ⇒ (back to the beginning)

ST	To listen to normal stereo playback.
L	To listen to the L (left) audio channel.
R	To listen to the R (right) audio channel.



For SVCD:

Ex.: ST 1 ⇒ ST 2 ⇒ L 1 ⇒ R 1 ⇒ L 2 ⇒ R 2 ⇒ (back to the beginning)

ST 1/ST 2	To listen to normal stereo playback of ST 1 or ST 2 channel.
L 1/L 2	To listen to the L (left) 1 or 2 audio channel.
R 1/R 2	To listen to the R (right) 1 or 2 audio channel.

The pop-up window goes off if no operation is done for about 5 seconds.

Using the on-screen bar

- 1 Press ON SCREEN repeatedly until the on-screen bar with pull-down menu appears on the TV.
- 2 Press cursor ► (or ◀) repeatedly to move  to  in the pull-down menu, then press ENTER.

The following pop-up window appears under the pull-down menu.

Ex.: "ST" (stereo) is selected.

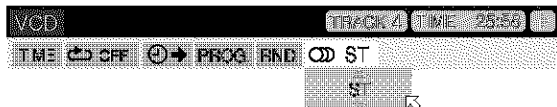

- 3 Press cursor ▼ (or ▲) repeatedly to select the desired audio channel(s).
 - Each time you press the button, the audio channels change.
- 4 Press ENTER.
 - The pop-up window goes off.

To turn off the on-screen bar

Press ON SCREEN.

Playing from a Specified Position on a Disc

You can start playing a title, chapter, group, or track you specify.

You can also play a disc from the specified time.

Before using the remote control, press DVD so that the remote control works for the DVD player.

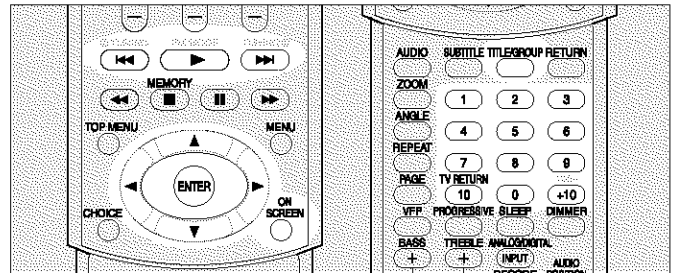

Locating a desired title/group

When playing back DVD VIDEO/DVD AUDIO, you can search for the title/group number to be played.



- While stopped or during playback

1 Press TITLE/GROUP.

The title/group number on the display changes as follows:

Ex.: When a DVD VIDEO is loaded.

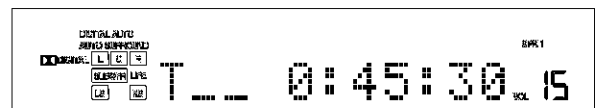

Ex.: When a DVD AUDIO is loaded.

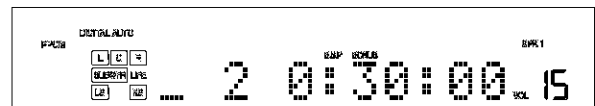

Now, the number buttons and ►/◀ buttons work for title/group selection for about 5 seconds.

2 Select the title/group number directly.

Press the number buttons (1 – 10, +10) to enter the desired title/group number.

- Ex.: To select title/group number 8, press 8.
 To select title/group number 11, press +10, then 1.
 To select title/group number 27, press +10, +10, then 7.

Playback starts from the first chapter/track in the specified title/group.

To skip titles/groups forward

Press TITLE/GROUP, then ►► repeatedly.

To skip titles/groups backward

Press TITLE/GROUP, then ◀◀ repeatedly.

Note:

- For DVD AUDIO only: When you select the bonus group, the key number entry indication appears (see page 42).

■ Locating a desired chapter/track

When playing back DVD VIDEO/DVD AUDIO, you can search for the chapter/track number to be played.



□ During playback

1 Press **ON SCREEN** repeatedly until the on-screen bar with pull-down menu appears on the TV.

2 Press cursor **▶** (or **◀**) repeatedly to move to **CHAP ▶** or **TRACK ▶** in the pull-down menu, then press **ENTER**.

The following pop-up window appears under the pull-down menu.

Ex.: When a DVD VIDEO is loaded.



Ex.: When a DVD AUDIO is loaded.

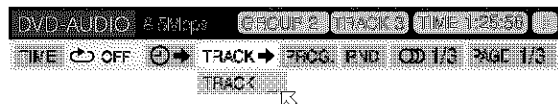

3 Press the number buttons (**0 – 9**) to enter the desired chapter/track number.

Ex.: To select chapter/track number 8, press 8.

To select chapter/track number 10, press 1 then 0.

To select chapter/track number 37, press 3 then 7.

- The +10 button is not used in this function.
- You can select up to the 99th chapter/track.

• To correct a misentry

Repeat step **3** until the desired number appears in the pop-up window.

4 Press **ENTER**.

The unit starts playback from the selected chapter/track.

To turn off the on-screen bar

Press **ON SCREEN**.

■ Locating a desired position

You can start playing at your desired position by specifying the elapsed playing time from the beginning of the current title up to "9:59:59" (for DVD VIDEO/DVD AUDIO), or from the beginning of the disc up to "99:59" (for VCD/SVCD/CD).



□ For DVD VIDEO: During playback

For VCD/SVCD: While stopped or during playback without PBC

For DVD AUDIO/CD: While stopped or during playback

1 Press **ON SCREEN** repeatedly until the on-screen bar with pull-down menu appears on the TV.

2 Press cursor **▶** (or **◀**) repeatedly to move to **TIME** in the pull-down menu, then press **ENTER**.

The following pop-up window appears under the pull-down menu.



3 Use the number buttons (**0 – 9**) to enter the time.

Ex.: To play back from a point of 1 (hours): 02 (minutes): 49 (seconds) from the beginning.

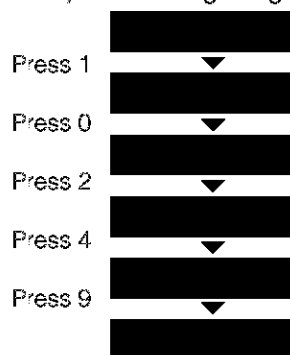

- The +10 button is not used in this function.
- You can specify the time in hours/minutes/seconds for DVD VIDEO/DVD AUDIO, and in minutes/seconds for VCD/SVCD/CD.

• To correct a misentry

Pressing cursor **◀** erases the last entry.

Press cursor **◀** repeatedly until the wrong number is erased, then press the number buttons to enter the correct number(s) again.

4 Press **ENTER**.

The unit starts playback from the specified time.

To turn off the on-screen bar

Press **ON SCREEN**.

Special Picture Playback

This unit provides special picture playback functions including still picture, frame-by-frame, slow-motion, and zoom.

Before using the remote control, press DVD so that the remote control works for the DVD player.

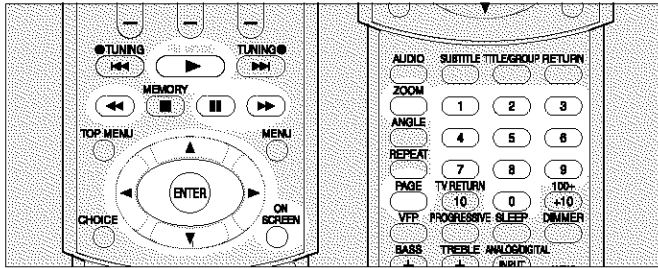

■ Still picture and frame-by-frame playback



During playback

1 Press II once.

Still picture playback begins.

2 Press II repeatedly.

- Each time you press the button, the still picture advances to the next frame.

To return to normal playback

Press ►.

Note:

- You can also perform the above operation using II on the front panel.

■ Playing back in slow-motion



During playback

1 Press II at the point where you want to start playback in slow-motion.

Still picture appears.

2 Press ►► or ◀◀.

To play back in forward slow-motion, press ►►.

To play back in reverse slow-motion (for DVD VIDEO only), press ◀◀.

- Each time you press the button, the playback speed changes as follows:

Forward:

1/32 ⇒ 1/16 ⇒ 1/8 ⇒ 1/4
⇒ 1/2

Reverse (for DVD VIDEO only):

1/32 ⇒ 1/16 ⇒ 1/8 ⇒ 1/4
⇒ 1/2

To pause slow-motion playback (still picture playback)

Press II.

To return to normal playback

Press ►.

Note:

- You cannot listen to the sound during slow-motion playback.

■ Selecting browsable still pictures recorded on DVD AUDIO

Most DVD AUDIOs include browsable still pictures (B.S.P), which usually appear in turn automatically during playback according to the playback sequence.

You can change the picture (turn the page) manually when the current still picture has selectable pages.



While the B.S.P indicator lights up on the display

Press PAGE repeatedly to select a desired still picture.

Using the on-screen bar

1 Press ON SCREEN repeatedly until the on-screen bar with pull-down menu appears on the TV.

2 Press cursor ► (or ◀) repeatedly to move to PAGE in the pull-down menu, then press ENTER.

The following pop-up window appears under the pull-down menu.

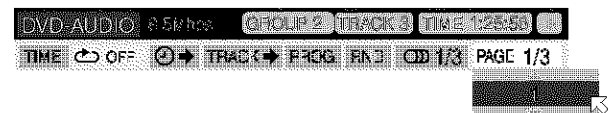

3 Press cursor ▼ (or ▲) repeatedly to select the desired page.

To turn off the on-screen bar

Press ON SCREEN.

■ Zooming in



- During playback or while paused

Press ZOOM.

- Each time you press the button, the magnification changes as follows:

x 1.8 ⇒ x 4 ⇒ x 8 ⇒ x 16 ⇒ x 32 ⇒ x 64 ⇒
x 1 (normal play) ⇒ (back to the beginning)

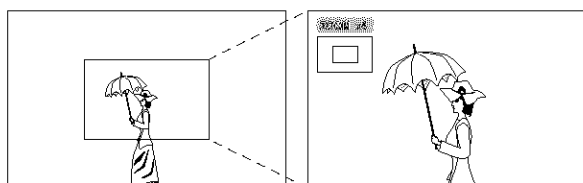

Ex.: When x4 zoom is selected

To move the zoomed-in position

Press cursor ▲/▼/▶/◀.

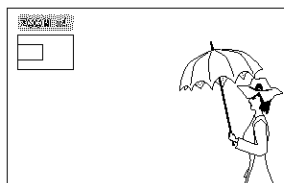

To return to normal playback

Press ENTER.

Note:

- While zoomed in, the picture may look coarse.

■ Playing back a bonus group

Some DVD AUDIOS have a special group called "bonus group" whose contents are not open to the public. The bonus group is always assigned to the last group of a disc (for example, if a disc contains 4 groups including a bonus group, "group 4" is the bonus group).

To play back a bonus group, you have to enter the specific "key number" (a kind of password) for the bonus group. The way of getting the key number depends on the disc. After getting the key number, you can play back the bonus group using the following procedure.



- While the BONUS indicator lights up

1 Select a bonus group.

For how to select the group, see "Locating a desired title/group" on page 39.

The key number entry indication appears as follows:

On the TV

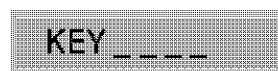

On the display



2 Enter the key number using the number buttons (0 – 9), then press ENTER.

When you enter the correct key number, the unit starts playing back the bonus group and the BONUS indicator goes off.

- If you enter the wrong number, enter the number again.

To turn off the key number entry

Perform one of the following:

- Press ■,
- Open the disc tray, or
- Turn off the unit.

Opening the disc tray or turning off the unit erases the memory of the key number, while pressing ■ does not erase the memory.

Notes:

- If you specify a track in the bonus group for the program playback, the key number entry indication in step 1 appears for entering the key number.
- In the random playback mode, tracks in the bonus group are not played back.

Changing the VFP Setting

The VFP (Video Fine Processor) function enables you to adjust the picture based on the picture tone, or personal preference.

Before using the remote control, press DVD so that the remote control works for the DVD player.

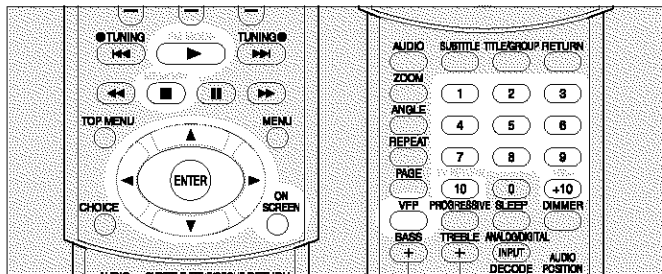

- There is a time limit in doing the following steps. If the setting is canceled before you finish, start from step 1 again.



□ During playback

1 Press VFP.

The current VFP setting screen appears on the TV.

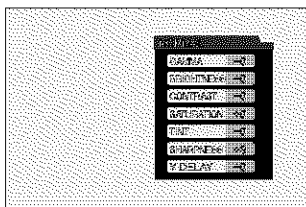

Ex.: When "NORMAL" is selected

2 Press cursor ► (or ◀) repeatedly to select the VFP mode.

- Each time you press the button, the VFP mode changes as follows.

NORMAL ⇄ **CINEMA** ⇄ **USER1** ⇄ **USER2** ⇄
(back to the beginning)

NORMAL	Normally select this.
CINEMA	Suitable for a movie source.
USER1/USER2	You can adjust parameters that affect the appearance of picture and store the settings (see the right column).

To turn off the VFP setting screen

Press VFP.

To adjust the appearance of the picture

You can adjust the appearance of picture and store in "USER1" and "USER2."

1 Press VFP, then press cursor ► (or ◀) repeatedly to select "USER1" or "USER2."

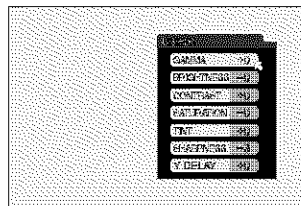

2 Press cursor ▼ (or ▲) repeatedly to select a parameter you want to adjust.

Adjust the parameters so that the picture you are viewing appears as you prefer.

GAMMA	Adjust if the neutral color is bright or dark. The brightness of dark and bright portions is maintained. Available range: -4 (darkest) to +4 (brightest)
BRIGHTNESS	Adjust if the picture is bright or dark on the whole. Available range: -16 (darkest) to +16 (brightest)
CONTRAST	Adjust if the far and near position is unnatural. Available range: -16 to +16
SATURATION	Adjust if the picture is whitish or blackish. Available range: -16 (most blackish) to +16 (whitest).
TINT	Adjust if the human skin color is unnatural. Available range: -16 to +16
SHARPNESS	Adjust if the picture is incinct. Available range: +0 to +3
Y DELAY	Adjust if the picture looks separately/overlapped. Available range: -2 to +2.

3 Press ENTER.

VFP parameters list disappears, and the following pop-up window for the selected item appears on the TV.

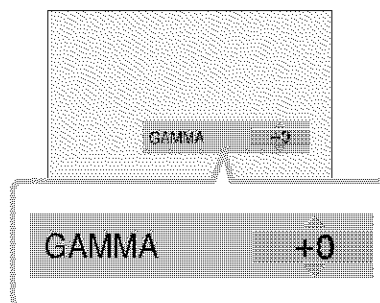

Ex.: When "GAMMA" is selected

4 Press cursor ▼ (or ▲) repeatedly to change the setting, then press ENTER.

Your adjustment is stored and the current VFP parameter list appears again.

5 Repeat steps 2 to 4 to adjust other parameters.

To turn off the VFP setting screen

Press VFP.

To activate your setting

Press VFP, then press cursor ► (or ◀) repeatedly to select "USER1" or "USER2."

Note:

- The VFP setting screen disappears if no operations are done for about 10 seconds.

Program Playback

You can play up to 99 tracks on DVD AUDIO/VCD/SVCD/CD in the desired order.

- You cannot use Resume play for program playback.
- You may program the same tracks more than once.

Before using the remote control, press DVD so that the remote control works for the DVD player.



While stopped

1 Press ON SCREEN repeatedly until the on-screen bar with pull-down menu appears on the TV.

2 Press cursor ► (or ◀) repeatedly to move to PROGRAM in the pull-down menu, then press ENTER.

For DVD AUDIO:

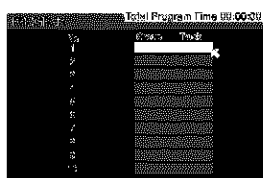

For VCD/SVCD/CD:

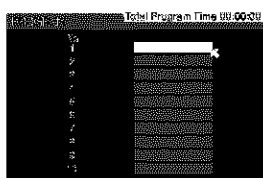

The program screen appears on the TV and the PROGRAM indicator lights up on the display.

- 10 steps appear at a time on the program screen.

3 Press the number buttons (1–10, +10) to enter a track/group you want to program.

Ex.: To select the track/group number 3, press 3.

To select the track/group number 14, press +10 then 4.

To select the track/group number 40, press +10, +10, +10 then 10.

- **For DVD AUDIO ONLY:** Enter a group number and a track number in order.
- When you enter a track/group number that does not exist on the loaded disc, your entry is ignored.
- The total program time is shown at the top of the program screen on the display.

For DVD AUDIO:



For VCD/SVCD/CD:

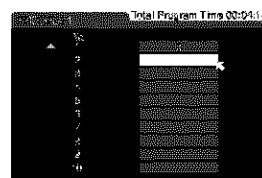

4 Repeat step 3 to program the next steps.

- Each time you enter a track number in the step at the bottom of the program screen, the next steps appear.

5 Press ►.

Playback starts in the programmed order.

Note:

- **For DVD AUDIO only:** If you select a bonus group in step 3, the key number entry indication appears. In this case, enter the key number to program a track in the bonus group (see page 42).

To erase a step

Press cursor ▲ (or ▼) to move to the desired step, then press ■.

- To program the next steps again, press cursor ▼ repeatedly to move to the blank step, then repeat step 3.

To stop the program playback

Press ■.

- When DVD AUDIO, VCD, or SVCD is played back, the program screen appears again.
- To edit your program, repeat steps 3 and 4.

To cancel the program playback mode

Clear the program you made as follows:

1 Press ■ to stop playback.

2 Press ON SCREEN to turn on the on-screen bar.

3 Press ■.

- You can also clear the program by ejecting the disc or turning off the unit.

To turn off the on-screen bar

Press ON SCREEN.

Note:

- When all the programmed tracks have been played, the program playback stops.

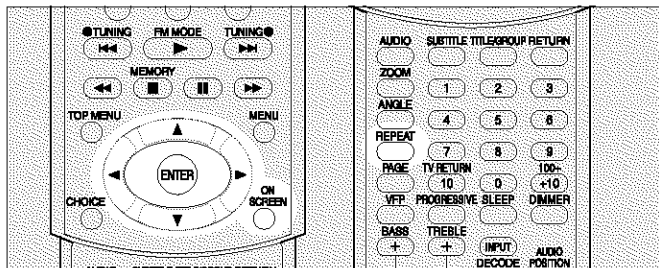

Random Playback

You can play tracks on DVD AUDIO/VCD/SVCD/CD in random order.

- You cannot use Resume play for random playback.

Before using the remote control, press DVD so that the remote control works for the DVD player.



- While stopped

1 Press ON SCREEN repeatedly until the on-screen bar with pull-down menu appears on the TV.

2 Press cursor ► (or ◀) repeatedly to move to RND in the pull-down menu, then press ENTER.

The RANDOM indicator lights up on the display and playback starts in random order.

To stop random playback

Press ■.

Random playback is canceled.

- When all tracks have been played once, random playback is also canceled.

Notes:

- The same track will not be played more than once during random playback.
- During random playback, you can skip back to the beginning of the current track by pressing ◀◀, but cannot skip back to the tracks that have been played.
- During random playback, pressing ENTER with RND selected in the on-screen bar cancels random playback and continues playback in the normal order.

Repeat Playback

You can repeat playback of the current title or chapter (for DVD VIDEO), group or track (for DVD AUDIO), or track (for VCD/SVCD/CD).

You can also repeat playback of a desired portion.

Before using the remote control, press DVD so that the remote control works for the DVD player.

Repeating a current title, group, chapter, or all tracks



- For DVD VIDEO: During playback
- For VCD/SVCD: During playback or while stopped without PBC
- For DVD AUDIO/CD: During playback or while stopped

1 Press ON SCREEN repeatedly until the on-screen bar with pull-down menu appears on the TV.

2 Press cursor ► (or ◀) repeatedly to move to the repeat icon in the pull-down menu, then press ENTER.

The following pop-up window appears under the pull-down menu.

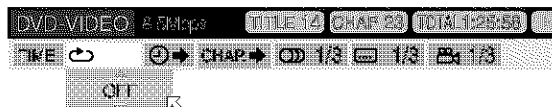

3 Press cursor ▼ (or ▲) repeatedly to select the repeat mode, then press ENTER.

- Each time you press cursor ▼ (or ▲), the repeat mode changes as follows:

For DVD VIDEO:

CHAPTER ⇄ TITLE ⇄ A-B ⇄ OFF ⇄
(back to the beginning)

For DVD AUDIO:

TRACK ⇄ ALL/GROUP ⇄ A-B ⇄ OFF ⇄
(back to the beginning)

For VCD/SVCD/CD:

TRACK ⇄ ALL ⇄ A-B ⇄ OFF ⇄
(back to the beginning)

CHAPTER	Repeats the current chapter (the REPEAT 1 indicator lights up on the display)
TRACK	Repeats the current track (the REPEAT 1 indicator lights up on the display)
TITLE	Repeats the current title (the REPEAT indicator lights up on the display)
ALL	Repeats all the tracks on the disc or of the program (the REPEAT indicator lights up on the display)
GROUP	Repeats all the tracks in a group (the REPEAT indicator lights up on the display)
A-B	Repeats a desired portion (see the right column)
OFF	Select to cancel the repeat mode

Notes:

- If you select "ALL" during random playback, the all tracks of the disc are played repeatedly in random order.
- "A-B" cannot be selected during the program and random playback or while a disc is not played back.

To turn off the on-screen bar

Press ON SCREEN.

To cancel the repeat playback

Select "OFF" in step 3, then press ENTER.

You can directly change the repeat mode (except A-B) by pressing REPEAT on the remote control.

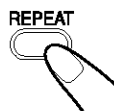

Repeating a desired portion

You can repeat playback of a desired portion by specifying the beginning (point A) and the ending (point B).



□ During playback

1 Follow steps 1 and 2 on page 45.

2 Press cursor ▼ (or ▲) repeatedly to select "A-B."

3 Press ENTER at the beginning of the portion you want to repeat (point A).

The following display appears in the on-screen bar. The REPEAT A indicator also lights up on the display.



4 Press ENTER at the end of the portion you want to repeat (point B).

A-B repeat playback starts. The selected part of the disc (between point A and B) is played repeatedly. During repeat A-B playback, the REPEAT A-B indicator lights up on the display.



Note:

- While playing back a DVD VIDEO, A-B repeat playback is possible only within the same title.

To turn off the on-screen bar

Press ON SCREEN.

To cancel the A-B repeat playback

Select "OFF" in step 3, then press ENTER.

MP3 Disc Playback

This unit can play back MP3 files on a CD-R or CD-RW. We call such a disc "MP3 disc" in this instruction.

- Before using the remote control, press DVD to change the remote control operation mode for the MP3 disc operations.
- Turn on your TV and select the correct input mode on the TV.

If "⊘" appears on the TV when you press a button, the disc cannot accept an operation you have tried to do.

■ Notes for MP3 discs

- MP3 discs (either CD-R or CD-RW) require a longer readout time than normal discs. (It depends on the complexity of the folder/file configuration.)
- When making an MP3 disc, select ISO 9660 Level 1 or Level 2 as the disc format.
- This unit supports "multi-session" discs (up to 5 sessions).
- This unit cannot play "packet write" discs.
- This unit can play MP3 files only with the following file extensions: ".MP3," ".Mp3," ".mp3," and ".mp3."
- ID3* tags cannot be shown on the display.
 - * An MP3 file can contain file information called an "ID3 Tag" where its album name, performer, track title, etc. are recorded. There are two versions—ID3v1 (ID3 Tag version 1) and ID3v2 (ID3 Tag version 2).
- It is recommended that you make each MP3 file at a sampling rate of 44.1 kHz and at bit rate of 128 kbps. The unit cannot play back files made at bit rate under 64 kbps.
- If both MP3 files and JPEG files are recorded on a disc, set the MP3/JPEG setting in the PICTURE menu to "MP3" (see page 54).
- Some MP3 discs may not be played back because of their disc characteristics or recording conditions.

The following functions are not available to MP3 disc playback:

- Program playback
- Random playback
- Fast-forward/reverse playback
- On-screen bar
- Choice menus

Note:

- Some tracks on an MP3 disc are skipped and may not be played back normally.

Before using the remote control, press DVD to change the remote control operation mode.

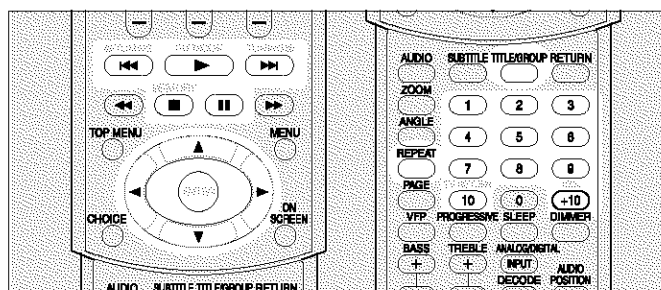

Basic Operations

You can also use the buttons on the front panel if they have names similar to those on the remote control.

Starting playback

Load an MP3 disc, then press ►.

- The unit starts playback. The MP3 CONTROL screen appears on the TV (see page 48).
- When all tracks in a group have been played, the unit plays tracks in the next group.

Stopping playback temporarily

Press ■.

To start playback again

Press ►.

Selecting groups or tracks

To skip groups forward

Press TITLE/GROUP, then press ►► as many times as required.

To skip groups backward

Press TITLE/GROUP, then press ◀◀ as many times as required.

To skip tracks forward

Press ►► as many times as required.

To skip to the beginning of the current track

Press ◀◀ once.

To skip tracks backward

Press ◀◀ as many times as required.

Stopping playback completely

Press ■.

Operations through the MP3 CONTROL Screen

You can search for and play the desired groups and tracks through the MP3 CONTROL screen shown on TV.

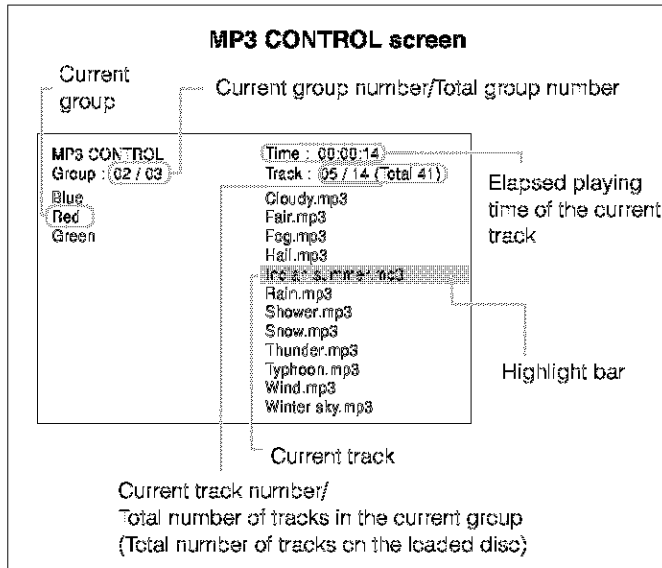

Notes:

- Some group and track names may not be displayed correctly because of their recording conditions.
- The order of groups and tracks on an MP3 disc may be displayed differently from the order displayed on your personal computer.
- Up to 12 groups and tracks are displayed on the TV at a time. Pressing cursor \blacktriangle / \blacktriangledown / \blacktriangleright / \blacktriangleleft repeatedly shows the hidden groups and tracks one by one.

Operations

During playback

To select a group

Press cursor \blacktriangleleft to move the highlight bar to the left group list; then press cursor \blacktriangledown (or \blacktriangle) repeatedly to select the desired group.

- When you select a group, the track list of the selected group is shown on the right.
- Playback starts from the first track in the selected group.

To select a track

Press cursor \blacktriangleright to move the highlight bar to the right track list; then press cursor \blacktriangledown (or \blacktriangle) repeatedly to select the desired track.

- Playback starts from the selected track.

To start playback by specifying a group number

1 Press TITLE/GROUP.

The number buttons now work for group selection for about 5 seconds.

The current group number on the display changes to “_”.

2 Press the number buttons (1 – 10, +10) to enter the group number.

Ex.:

- To select 8 for group number, press 8.
- To select 11 for group number, press +10, then 1.
- To select 27 for group number, press +10, +10, then 7.

The selected group number appears in the group number indication, then playback starts from the first track in the specified group.

Repeat Playback

You can repeat playback of the current track, group, or all the tracks on the loaded disc.

During playback or while stopped

From the remote control ONLY

Press REPEAT.

The repeat indication appears on the MP3 CONTROL screen.

- Each time you press the button, the repeat mode changes as follows:

REPEAT TRACK \rightleftharpoons REPEAT GROUP \rightleftharpoons
 REPEAT ALL \rightleftharpoons the indication goes off \rightleftharpoons
 (back to the beginning)

REPEAT TRACK	Repeats the current track. The REPEAT 1 indicator lights up on the display.
REPEAT GROUP	Repeats the current group. The REPEAT indicator lights up on the display.
REPEAT ALL	Repeats all the tracks on the disc. The REPEAT indicator lights up on the display.

To cancel repeat mode

Press REPEAT repeatedly until the repeat indication goes off from the MP3 CONTROL screen (the REPEAT indicator also goes off from the display).

JPEG Disc Playback

This unit can play back JPEG files on a CD-R or CD-RW. We call such a disc "JPEG disc" in this instruction.

- **Before using the remote control, press DVD to change the remote control operation mode for the JPEG disc operations.**
- Turn on your TV and select the correct input mode on the TV.

If "⊘" appears on the TV when you press a button, the disc cannot accept an operation you have tried to do.

■ Notes for JPEG

- JPEG discs (either CD-R or CD-RW) require a longer readout time than normal discs. (It depends on the complexity of the folder/file configuration.)
- When making a JPEG disc, select ISO 9660 Level 1 or Level 2 as the disc format.
- This unit supports "multi-session" discs (up to 5 sessions).
- This unit cannot play "packet write" discs.
- The unit can play JPEG files only with the following file extensions: ".jpg," ".jpeg," ".JPG," ".JPEG" and any uppercase and lowercase combinations (such as ".Jpg").
- It is recommended that you record a file at 640 x 480 resolution. (If a file has been recorded at a resolution of more than 640 x 480, it will take a longer time to be shown.)
- If both JPEG files and MP3 files are recorded on a disc, set the MP3/JPEG setting in the PICTURE menu to "JPEG." (See page 54.)
- This system can play only baseline JPEG files*. Progressive JPEG files* or lossless JPEG files* cannot be played.
 - * – Baseline JPEG format: Used for digital cameras, web, etc.
 - Progressive JPEG format: Used for web.
 - Lossless JPEG format: An old type and rarely used now.
- Some JPEG discs may not be played back because of their disc characteristics or recording conditions.

Before using the remote control, press DVD to change the remote control operation mode.

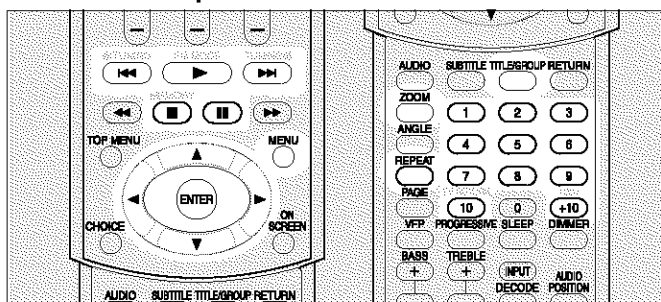

Slide-show Playback

You can play back the still pictures one after another automatically—slide-show playback. You can also use the buttons on the front panel if they have names similar to those on the remote control.

Starting slide-show playback

Load a JPEG disc, then press ►.

- Slide-show playback starts. Each file (still picture) is shown on the TV for about 3 seconds, then changed to the next file, one after another.
- When all files in a group have been played back, the unit plays back files in the next group.

Stopping slide-show playback temporarily

Press II.

- You can zoom in on the still picture (see page 50).

To start slide-show playback again

Press ►.

Starting the slide-show playback by specifying a group number

1 Press TITLE/GROUP.

The number buttons now work for group selection for about 5 seconds.

The current group number on the display changes to " _ _".

2 Press the number buttons (1 – 10, +10) to enter the group number.

Ex.:

- To select 8 for group number, press 8.
- To select 11 for group number, press +10, then 1.
- To select 27 for group number, press +10, +10, then 7.

The selected group number appears in the group number indication, then slide-show playback starts from the first file in the specified group.

Starting the slide-show playback by specifying a file number

Press the number buttons (1 – 10, +10) to enter the file number.

Ex.: To select the file number 3, press 3.

To select the file number 14, press +10 then 4.

To select the file number 24, press +10, +10, then 4.

To select the file number 110, press +10 ten times, then 10.

The selected file number appears in the file number indication, then the slide-show playback starts from the file you have specified.

Selecting files or groups

To skip groups forward

Press TITLE/GROUP, then press ►► as many times as required.

To skip groups backward

Press TITLE/GROUP, then press ◀◀ as many times as required.

To skip pictures (files) forward

Press ►► as many times as required.

To skip pictures (files) backward

Press ◀◀ as many times as required.

Stopping slide-show playback completely

Press ■.

The JPEG CONTROL screen appears on the TV.

- For how to operate through the JPEG CONTROL screen, see "Operations through the JPEG CONTROL Screen" below.

Notes:

- The following functions are not available to the slide-show playback: program playback, random playback, repeat playback, fast-forward/reverse playback, on-screen bar, and choice menus.
- If a black screen continuously appears in the slide-show playback: the file currently played may be non-baseline JPEG file. In this case, select a playable file (a baseline JPEG file) again (e.g., pressing ■ or MENU to open the JPEG CONTROL screen, etc.). Note that it may take a long time to select another file.
- Some files on a JPEG disc may be distorted during playback.

Operations through the JPEG CONTROL Screen

You can search for and show the desired groups and files through the JPEG CONTROL screen.

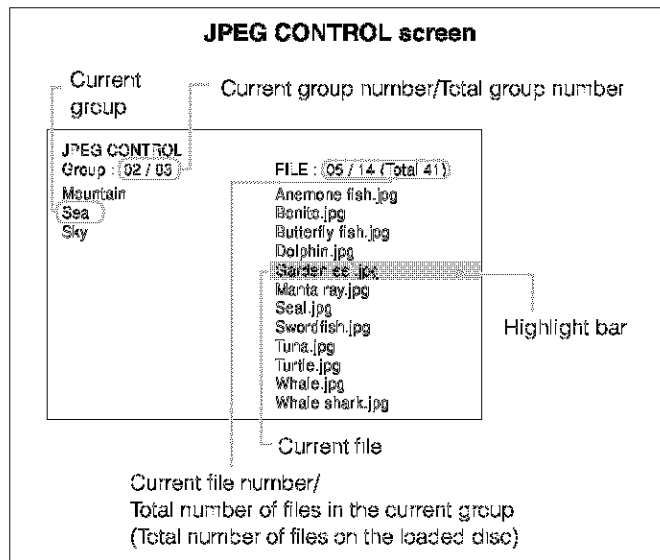

Notes:

- You can check the group number and the file number on the display window.
- Some group and file names may not be displayed correctly because of the recording condition.
- The order of groups and files on a JPEG disc may be displayed differently from the order displayed on your personal computer.
- Up to 12 groups and files are displayed on the TV at a time. Pressing cursor ▲/▼/▶/◀ repeatedly shows the hidden groups and files one by one.

Showing the selected file

1 Select a group.

Press cursor ◀ to move the highlight bar to the left group list, then press cursor ▼ (or ▲) repeatedly to select the desired group.

- When you select a group, the file list of the selected group is shown on the right.

2 Select a file.

Press cursor ▶ to move the highlight bar to the right file list, then press cursor ▼ (or ▲) repeatedly to select the desired file.

3 Press ENTER.

- When the still picture appears on the TV completely, you can zoom in or out the still picture (see below).
- If you press ▶, the slide-show playback starts from the selected file.

Zooming in on the still picture

See also page 42.

Press ZOOM.

- Each time you press the button, the magnification changes as follows:

x 1.8 ⇨ x 4 ⇨ x 8 ⇨ x 16 ⇨ x 32 ⇨ x 64 ⇨
x 1 (normal play) ⇨ (back to the beginning)

To move the zoomed-in position

Press cursor ▲/▼/▶/◀.

To return to normal playback

Press ENTER.

To return to the JPEG CONTROL screen

Press MENU or ■.

Repeat Playback

You can repeat playback of the current group or all the files on the loaded disc.

□ During playback or while stopped

From the remote control ONLY

Press REPEAT.

The repeat indication appears on the JPEG CONTROL screen and the REPEAT indicator lights up on the display.

- Each time you press the button, the repeat mode changes as follows:

REPEAT GROUP ⇨ REPEAT ALL ⇨
the indication goes off ⇨ (back to the beginning)

REPEAT GROUP	Repeats the current group
--------------	---------------------------

REPEAT ALL	Repeats all the files on the disc
------------	-----------------------------------

To cancel repeat mode

Press REPEAT repeatedly until the repeat indication goes off from the JPEG CONTROL screen (the REPEAT indicator also goes off from the display).

Choice Menu Operations

You can adjust the initial settings through the choice menu on the TV.

Before operating the choice menu, select the source you want to adjust by pressing source selecting button.

- When selecting FM or AM as the source, you cannot use the choice menu.
- When selecting a source other than DVD, FM, and AM, you can use the AUDIO and SPK. SETTING menus. The audio adjustments are memorized for each selected source.

Notes:

- You need to turn on your TV and select the correct input mode on the TV.
- You can use only the remote control for the choice menu operations.
- You can change the language used in the choice menu. See page 53.
- You cannot show the choice menu when an MP3 disc or a JPEG disc is loaded.

■ Operation buttons

To do the operations in this choice menu, use the buttons on the remote control.

From the remote control ONLY

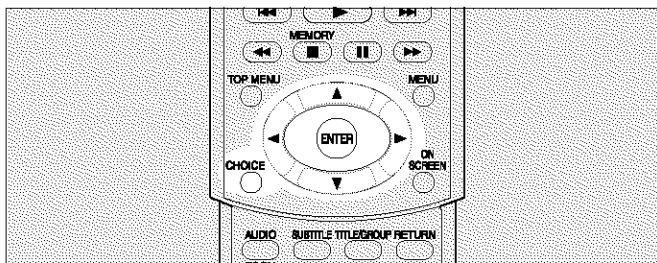

Button	To do
CHOICE	Display the choice menu on the TV. Each time you press the button, the choice menu is turned on and off alternately.
▲/▼	Select an item.
▶/◀	Adjust the selected item on the choice menu.
ENTER	Move to the submenu of the selected item or confirm the setting.

■ Configuration of Choice menu

The choice menu has the following menus:

LANGUAGE menu (see page 53)

You can select the initial language for the disc menu, audio, and subtitle. You can also select the language used on the TV screen while operating this unit.

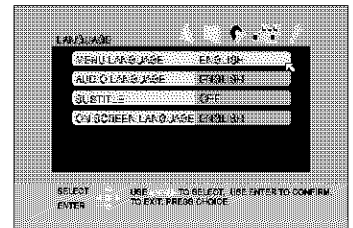

PICTURE menu (see page 53)

You can select the desired options concerning a picture or monitor screen.

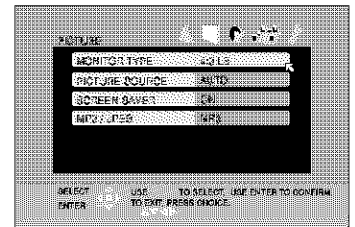

AUDIO menu (see page 54)

You can adjust the sound settings of this unit through this menu.

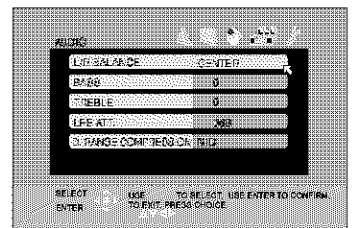

SPK. SETTING menu (see page 55)

You can adjust the speaker settings. You can also adjust the output level of the speakers.

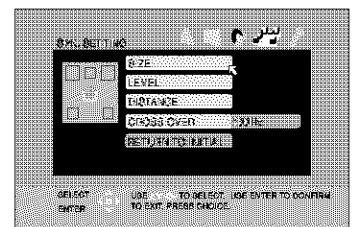

OTHERS menu (see page 56)

You can change the settings for some of the functions. To set Parental Lock, use this menu.

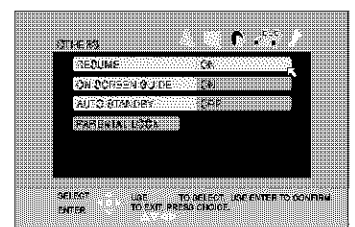

■ Operating procedure

Ex.: When setting the picture source.

Before operating the choice menu, press DVD to change the source to "DVD."

1 Press CHOICE.

The LANGUAGE menu appears on the TV.



2 Press cursor > (or <) repeatedly to display PICTURE menu.

- Each time you press the button, the menu changes.

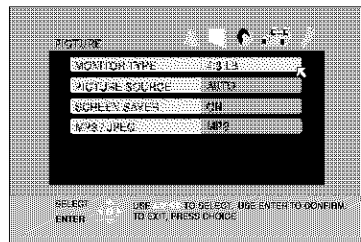

3 Press cursor < (or >) repeatedly to move to "PICTURE SOURCE."

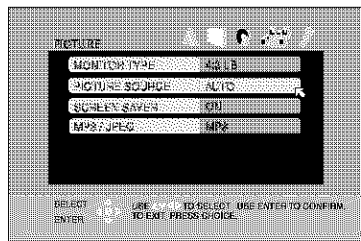

4 Press ENTER.

The pop-up window appears listing the selectable options.

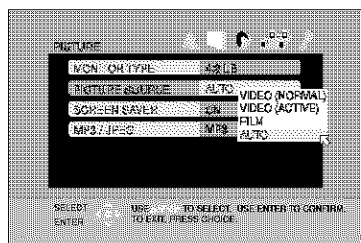

5 Press cursor < (or >) repeatedly to select the desired option.

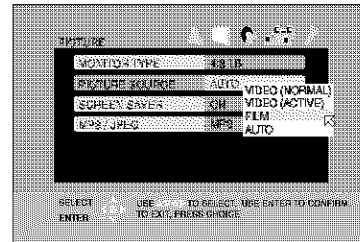

Ex.: When "FILM" is selected.

6 Press ENTER to finish the setting.

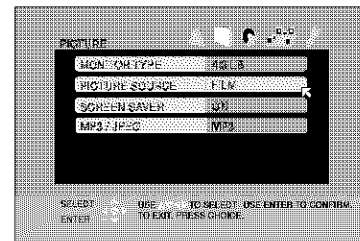

To set other items on the same choice menu

Repeat steps 3 to 6.

To move to another choice menu

Press cursor > (or <) repeatedly to select a choice menu you want to set up.

To return to the normal screen

Press CHOICE.

Note:

- Some items in the choice menu consist of submenus for setting up various options. Pressing ENTER makes the submenu for the selected item appear on the TV. You can set the items using cursor </> and ENTER (as explained in steps 5 and 6 above).

■ Language selection menu—LANGUAGE



You can select "MENU LANGUAGE," "AUDIO LANGUAGE," and "SUBTITLE" only before playback.

● MENU LANGUAGE

Some discs have multiple languages. Select one of the languages or language codes from AA to ZU (see "Language code list" on page 54) as the menu language.

● AUDIO LANGUAGE

Some discs have multiple audio languages. Select one of the languages or language codes from AA to ZU (see "Language code list" on page 54).

● SUBTITLE

Some discs have multiple subtitle languages. Select one of the languages or language codes from AA to ZU (see "Language code list" on page 54) or "OFF (no subtitle)."

Note:

- When the language you have selected for **MENU LANGUAGE**, **AUDIO LANGUAGE**, or **SUBTITLE** is not recorded on a disc, the original language is used as the initial language automatically.

● ON SCREEN LANGUAGE

Select one of the languages shown on the TV.

■ Picture setting menu—PICTURE

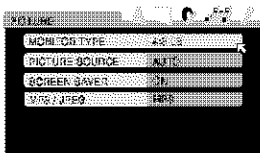

● MONITOR TYPE

You can select the monitor type to match your TV when you play DVD VIDEO recorded in the picture's width/height ratio of 16:9.

Select one of the following settings:

16:9 NORMAL (Wide television conversion)

Select when the aspect ratio of your TV is fixed to 16:9 (wide TV). The unit automatically adjusts the screen width of the output signal correctly when playing back a picture whose aspect ratio is 4:3.

16:9 AUTO (Wide television conversion)

Select when the aspect ratio of your TV is 16:9 (wide TV).

4:3 LB (Letter Box conversion)

Select when the aspect ratio of your TV is 4:3 (conventional TV). While viewing a wide screen picture, the black bars appear on the top and the bottom of the screen.

4:3 PS (Pan Scan conversion)

Select when the aspect ratio of your TV is 4:3 (conventional TV). While viewing a wide screen picture, the black bars do not appear; however, the left and right edges of the pictures will not be shown on the screen.

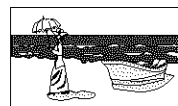

Ex.: 16:9

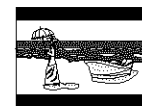

Ex.: 4:3 LB

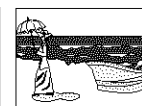

Ex.: 4:3 PS

- Even if "4:3 PS" is selected, the screen size may become "4:3 LB" with some DVD VIDEOS. This depends on how the discs are recorded.
- When you select "16:9 NORMAL" for a picture whose aspect ratio is 4:3, the picture slightly changes due to the process for converting the picture width.

● PICTURE SOURCE

You can select the picture source according to the picture type (film or video source). This takes effect only when "PROGRESSIVE" is selected as the scanning mode (see page 16).

Normally, set to "AUTO."

Select one of the following settings:

VIDEO (NORMAL)

Suitable for playing back a video source disc with relatively a few movements.

VIDEO (ACTIVE)

Suitable for playing back a video source disc with relatively a lot of movements.

FILM

Suitable for playing back a film or progressive source disc.

AUTO

Used to play a disc containing both video and film source materials. This unit recognizes the picture type (film or video source) of the current disc according to the disc information.

- If the playback picture is unclear or noisy, or the oblique lines of the picture are rough, try changing to other modes.

● **SCREEN SAVER**

You can activate or deactivate the screen saver function.

Select one of the following settings:

ON	The picture on the TV becomes dark when no operation is done for 5 minutes.
OFF	The screen saver function does not work.

● **MP3/JPEG**

If both MP3 files and JPEG files are recorded on a disc, you can select which files to play.

Select one of the following settings:

MP3	Select for playing MP3 files.
JPEG	Select for playing JPEG files.

■ **Audio selection menu—AUDIO**



You can also adjust the following items using the front panel or remote control (see pages 21 to 24).

● **L/R BALANCE**

Adjust the output balance between the left front speaker and right front speaker within the range of "R-21" to "CENTER" or "CENTER" to "L-21."

● **BASS**

Adjust the bass tone level from the front speakers within the range of -10 dB to +10 dB in 2 step intervals.

● **TREBLE**

Adjust the treble tone level from the front speakers within the range of -10 dB to +10 dB in 2 step intervals.

● **LFE ATT.**

The Low Frequency Effect attenuator diminishes the distortion of the bass sound from the subwoofer while playing back a disc with Dolby Digital or DTS Digital Surround.

Select one of the following settings:

-10dB	Select to diminish the distortion of the bass sound from the subwoofer.
0dB	Select to cancel this function.

● **D. RANGE COMPRESSION**

You can enjoy a powerful sound at night even at a low volume level when listening to the sound with Dolby Digital.

Select one of the following settings:

MAX	Select when you want to apply the compression effect fully (useful after midnight).
MID	Select when you want to reduce the dynamic range a little.
OFF	Select when you want to enjoy surround with its full dynamic range (no effect applied).

Language code list

AA	Afar	FA	Persian	KM	Cambodian	OM	(Afan) Oromo	SU	Sundanese
AB	Abkhazian	FI	Finnish	KN	Kannada	OR	Oriya	SV	Swedish
AF	Afrikaans	FJ	Fiji	KC	Korean (KOR)	PA	Panjabi	SW	Swahili
AM	Ameharic	FO	Faroese	KS	Kashmiri	PL	Polish	TA	Tamil
AR	Arabic	FY	Frisian	KU	Kurdish	PS	Pashto, Pushto	TE	Telugu
AS	Assamese	GA	Gaelic	KY	Kirghiz	PT	Portuguese	TG	Tajik
AY	Aymara	GD	Scotts Gaelic	LA	Latin	QU	Quechua	TH	Thai
AZ	Azerbaijani	GL	Galician	LN	Lingala	RM	Rhaeto-Romance	TI	Tigrinya
BA	Bashkir	GN	Guarani	LO	Laotian	RN	Kirundi	TK	Turkmen
BE	Byelorussian	GU	Gujarati	LT	Lithuanian	RO	Rumanian	TL	Tagalog
BG	Bulgarian	HA	Hausa	LV	Latvian, Lettish	RU	Russian	TN	Setswana
BH	Bihari	HI	Hindi	MG	Malagasy	RW	Kinyarwanda	TO	Tonga
BI	Bislama	HR	Croatian	MI	Maori	SA	Sanskrit	TR	Turkish
BN	Bengali, Bangla	HU	Hungarian	MK	Macedonian	SD	Sindhi	TS	Tsonga
BC	Tibetan	HY	Armenian	ML	Malayalam	SG	Sangho	TT	Tatar
BR	Breton	IA	Interlingua	MN	Mongolian	SH	Serbo-Croatian	TW	Twi
CA	Catalan	IE	Interlingue	MO	Moldavian	S	Singhalese	UK	Ukrainian
CO	Corsican	IK	Inupiak	MR	Marathi	SK	Slovak	UR	Urdu
CS	Czech	IN	Indonesian	MS	Malay (MAY)	SL	Slovenian	UZ	Uzbek
CY	Welsh	IS	Icelandic	MT	Maltese	SM	Samoan	VI	Vietnamese
DA	Danish	IW	Hebrew	MY	Burmese	SN	Shona	VO	Volapuk
DZ	Bhutani	JL	Yiddish	NA	Nauru	SO	Somali	WO	Wolof
EL	Greek	JW	Javanese	NE	Nepali	SQ	Albanian	XH	Xhosa
EO	Esperanto	KA	Georgian	NL	Dutch	SR	Serbian	YO	Yoruba
ET	Estonian	KK	Kazakh	NO	Norwegian	SS	Siswati	ZU	Zulu
EJ	Basque	KL	Greenlandic	OC	Occitan	ST	Sesotho		

■ Speaker setting menu—SPK. SETTING



● SIZE

Select this to enter the SIZE submenu.



FRONT SPEAKER, CENTER SPEAKER, and SURROUND SPEAKER

Select one of the following settings for each speaker:

LARGE	Select when the size of the cone speaker unit built in your speaker is greater than 12 cm (4 3/4 inches).
SMALL	Select when the size of the cone speaker unit built in your speaker is smaller than 12 cm (4 3/4 inches).
NONE	Select when you have not connected a speaker (not selectable for the front speakers).

SUB WOOFER

Select one of the following settings:

USE	Select when a subwoofer is connected.
NONE	Select when no subwoofer is used.

RETURN

Select this to return to SPK. SETTING menu.

Notes:

- If you have selected "SMALL" for the front speakers, you cannot select "LARGE" for the center and surround speakers.
- If you have selected "NONE" for subwoofer, you cannot select "SMALL" for the front speakers.
- You can take advantage of the speaker diagrams on the left part of the SPK. SETTING menu to set the speaker.
 - The speaker diagram for the selected speaker is highlighted.
 - The size of the speaker diagram is changed according to your settings.

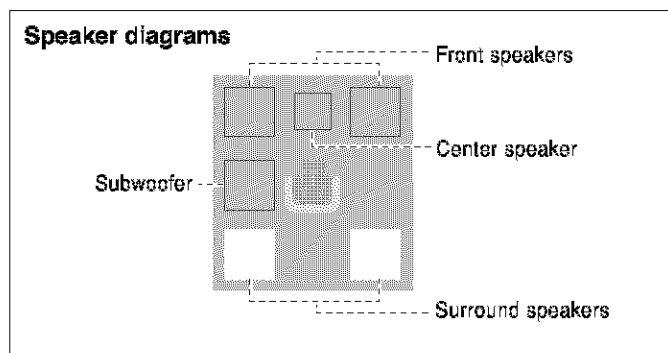

● LEVEL

Select this to enter the LEVEL submenu.



CENTER SPEAKER, SURROUND LEFT SPEAKER, SURROUND RIGHT SPEAKER, and SUB WOOFER

Adjust the speaker output level within the range of -10 dB to +10 dB for each speaker in 1 step intervals.

TEST TONE

Select this to start or stop test tone.

RETURN

Select this to return to SPK. SETTING menu.

Notes:

- When "NONE" is selected for the center speaker, surround speakers, and/or subwoofer on the SIZE menu, "-" appears instead of the current setting. In this case, you cannot adjust the output level of those speakers.
- You can adjust the output level for center speaker and/or surround speakers only when one of the proper Surround modes is activated (see page 30).
- When "NONE" is selected for the center and/or surround speakers on the SIZE menu, the test tone does not come out of those speakers.

● DISTANCE

Select this to enter the DISTANCE submenu.



FRONT SPEAKER, CENTER SPEAKER, and SURROUND SPEAKER

For each speaker, set the distance from the listening point within the range of 0.3 m (1 ft) to 9.0 m (30 ft), in 0.3 m (1 ft) intervals.

TEST TONE

Select this to start or stop test tone.

RETURN

Select this to return to SPK. SETTING menu.

Notes:

- When "NONE" is selected for the center speaker and surround speakers on the SIZE menu, "-" appears instead of the current setting. In this case, you cannot adjust the speaker distance of those speakers.
- When "NONE" is selected for the center speaker and/or surround speakers on the SIZE menu, the test tone does not come out of those speakers.

● CROSS OVER

When you use a small speaker in any position, this unit automatically reallocates the bass sound elements assigned to the small speaker to the large speakers. To use this function properly, set this crossover frequency level according to the size of the smallest speaker connected.

- If you have selected "LARGE" (or "LRG (large)"—see page 23) for all speakers, this function will not take effect.

Select one of the following settings:

120Hz	Select when the cone speaker unit built in the speaker is about 8 cm (3 ³ / ₁₆ inches).
100Hz	Select when the cone speaker unit built in the speaker is about 10 cm (3 ¹⁵ / ₁₆ inches).
80Hz	Select when the cone speaker unit built in the speaker is about 12 cm (4 ³ / ₄ inches).

● RETURN TO INITIAL

Select this to reset all speaker settings to the initial settings.

■ Other setting menu—OTHERS



● RESUME

You can activate or deactivate the resume play function of the built-in DVD player.

Select one of the following settings:

ON	Select to activate this function.
OFF	Select to deactivate it.

● ON SCREEN GUIDE

You can activate or deactivate the following on-screen guide icons:

For multi-view angles:



For multilingual subtitles:



For multilingual audio languages: 

For playback status:



The on-screen guide icons appear on the TV at the beginning of the playback with this function turned on.

When recording the picture on a VCR, select "OFF" to avoid recording the indications above on your video tape.

- The choice menu and on-screen bar will be recorded even though this function is set to "OFF."

Select one of the following settings:

ON	Select to activate this function.
OFF	Select to deactivate it.

- Subtitles and the information for zooming in (see page 42) always appear on the display regardless of this setting.

● AUTO STANDBY

When the playback of the disc on the built-in DVD player ends and no operation is done for more than the selected time, the unit is turned off automatically.

- This function takes effect only when "DVD" is selected as the source.

Select one of the following settings:

60	Select to turn off the unit if no operation is done within 60 minutes.
30	Select to turn off the unit if no operation is done within 30 minutes.
OFF	Select to deactivate it.

- If Sleep Timer (see page 14) and Auto Standby are used at the same time, the one with the earlier shut-off time will turn off the unit.

● PARENTAL LOCK

You can restrict playback of DVD VIDEO containing violent scenes and those not suitable for your family members.

- You can select "PARENTAL LOCK" only before playback.

Select this to enter the PARENTAL LOCK submenu. (See pages 57 and 58.)

Choice Menu Operations

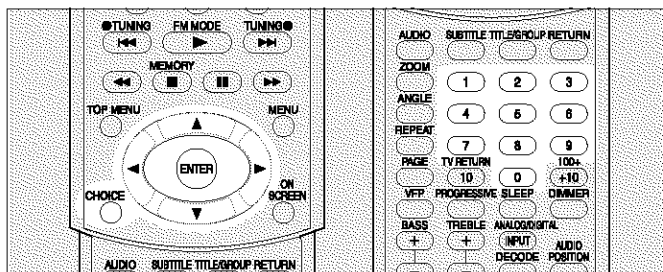

Restricting Playback by Parental Lock

You can restrict playback of DVD VIDEO containing violent scenes and those not suitable for your family members. Nobody can play such a disc unless this function is canceled.

- This setting takes effect only for a DVD VIDEO containing Parental Lock level information—Level 1 (most restrictive) to Level 8 (least restrictive). Playback of discs containing higher level than the selected level will be restricted. Some discs may not be played back at all, and others may be played back with higher level scenes skipped.
Ex.: When you select "4," discs containing level 5, 6, 7, or 8 can be played back.
- You can set the Parental Lock only while playback is stopped.

■ Setting Parental Lock

- 1 Press CHOICE, then press cursor ► (or ◀) to display the OTHERS menu.**
- 2 Press cursor ▼ (or ▲) repeatedly to move to "PARENTAL LOCK," then press ENTER.**
The PARENTAL LOCK submenu appears on the TV.

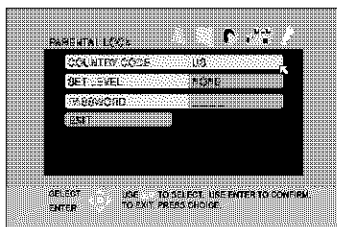

- 3 Press cursor ▼ (or ▲) repeatedly to move to "COUNTRY CODE," then press ENTER.**
The pop-up window for setting the country code appears.

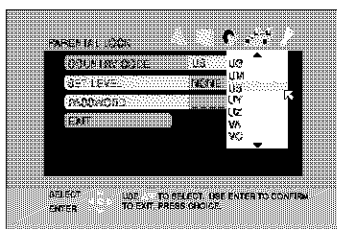

- See "Country/Area codes list for Parental Lock" on page 59.

- 4 Press cursor ▼ (or ▲) repeatedly to select the country code, then press ENTER.**

↵ moves to "SET LEVEL."

- 5 Press ENTER.**

The pop-up window for setting level appears.

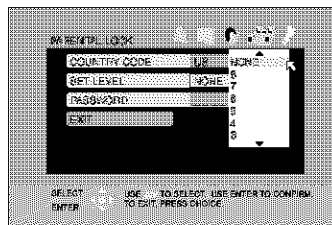

- 6 Press cursor ▼ (or ▲) repeatedly to select the level of restriction, then press ENTER.**

↵ moves to "PASSWORD."

- The smaller the value of level is, the more restrictive the Parental Lock level is.
- Select "NONE" to cancel this function.



- 7 Press the number buttons (0 – 9) to enter a four digit number as your password, then press ENTER.**

↵ moves to "EXIT."

- 8 Press ENTER.**

OTHERS menu resumes.

To return to the normal screen

Press CHOICE.

Note:

- Remember your password or make a note of it. You need to enter your password to change the setting or release the lock. To change the setting, see page 59.

■ Changing the Parental Lock setting

- 1 Press **CHOICE**, then press cursor **▶** (or **◀**) to display the **OTHERS** menu.
- 2 Press cursor **▼** (or **▲**) repeatedly to move to **"PARENTAL LOCK,"** then press **ENTER**.

The **PARENTAL LOCK** submenu appears on the TV.

- You can only move **↔** to **"PASSWORD"** or to **"EXIT"** before you enter your password.

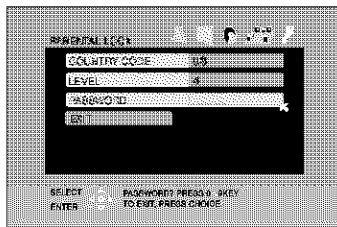

- 3 Press the number buttons **(0 – 9)** to enter your password, then press **ENTER**.

- If you enter a wrong password, **"WRONG! RETRY... PRESS 0~9KEY"** appears on the **PARENTAL LOCK** submenu. You cannot go to next steps before you enter the correct password.

- 4 Press cursor **▼** (or **▲**) repeatedly to move to the item you want to change, then press **ENTER**.

- 5 Press cursor **▼** (or **▲**) repeatedly to change the setting, then press **ENTER**.

- 6 Press the number buttons **(0 – 9)** to enter your password, then press **ENTER**.

The new setting is stored.

Notes:

- You cannot change the Parental Lock before you enter your password.
- If you go out of the **PARENTAL LOCK** submenu before setting your password in step 6, the new country code and parental level will not become effective, and the old country code and parental level remain effective.
- When you enter wrong passwords more than three times, **↔** moves to **"EXIT"** automatically and cursor **▼** (or **▲**) does not work. Press **ENTER** to exit from the **PARENTAL LOCK** submenu, then start from step 1 again.
- If you forget your password, enter **"8888."**

■ Releasing Parental Lock temporarily

When you set a strict parental level, some discs may not be played back at all. When you load such a disc and try to play it, the following display appears on the TV. You can release Parental Lock temporarily.



- 1 Press cursor **▼** (or **▲**) repeatedly to move to **"TEMPORARY RELEASE,"** then press **ENTER**.

↔ moves to **"PASSWORD."**

- If you do not want to release Parental Lock temporarily, select **"NOT RELEASE"** by pressing cursor **▼** (or **▲**), then press **ENTER**. To eject the disc, press **OPEN/CLOSE** (or **▲** on the front panel).

- 2 Press number buttons **(0 – 9)** to enter your password, then press **ENTER**.

Playback starts.

- If you enter a wrong password, **"WRONG! RETRY... PRESS 0~9KEY"** appears on the **PARENTAL LOCK** submenu. You cannot play the disc before you enter the correct password.

Note:

- When you enter a wrong password more than three times, **↔** moves to **"NOT RELEASE"** automatically and cursor **▼** (or **▲**) does not work. Press **OPEN/CLOSE** (or **▲** on the front panel) to remove the disc.

Country/Area codes list for Parental Lock

AD	Andorra	ER	Eritrea	LA	Lao People's Democratic Republic	RW	Rwanda
AE	United Arab Emirates	ES	Spain	LB	Lebanon	SA	Saudi Arabia
AF	Afghanistan	ET	Ethiopia	LC	Saint Lucia	SB	Solomon Islands
AG	Antigua and Barbuda	FI	Finland	LI	Liechtenstein	SC	Seychelles
AI	Anguilla	FJ	Fiji	LK	Sri Lanka	SD	Sudan
AL	Albania	FK	Falkland Islands (Malvinas)	LR	Liberia	SE	Sweden
AM	Armenia	FM	Micronesia (Federated States of)	LS	Lesotho	SG	Singapore
AN	Netherlands Antilles	FO	Faeroe Islands	LT	Lithuania	SH	Saint Helena
AO	Angola	FR	France	LU	Luxembourg	SI	Slovenia
AQ	Antarctica	FX	France, Metropolitan	LV	Latvia	SJ	Svalbard and Jan Mayen
AR	Argentina	GA	Gabon	LY	Libyan Arab Jamahiriya	SK	Slovakia
AS	American Samoa	GB	United Kingdom	MA	Morocco	SL	Sierra Leone
AT	Austria	GD	Grenada	MC	Monaco	SM	San Marino
AU	Australia	GE	Georgia	MD	Moldova, Republic of	SN	Senegal
AW	Aruba	GF	French Guiana	MG	Madagascar	SO	Somalia
AZ	Azerbaijan	GH	Ghana	MH	Marshall Islands	SR	Suriname
BA	Bosnia and Herzegovina	GI	Gibraltar	ML	Mali	ST	Sao Tome and Principe
BB	Barbados	GL	Greenland	MM	Myanmar	SV	El Salvador
BD	Bangladesh	GM	Gambia	MN	Mongolia	SY	Syrian Arab Republic
BE	Belgium	GN	Guinea	MO	Macau	SZ	Swaziland
BF	Burkina Faso	GP	Guadeloupe	MP	Northern Mariana Islands	TC	Turks and Caicos Islands
BG	Bulgaria	GQ	Equatorial Guinea	MQ	Martinique	TD	Chad
BH	Bahrain	GR	Greece	MR	Mauritania	TF	French Southern Territories
BI	Burundi	GS	South Georgia and the South Sandwich Islands	MS	Montserrat	TG	Togo
BJ	Benin	GT	Guatemala	MT	Malta	TH	Thailand Code Language
BM	Bermuda	GU	Guam	MU	Mauritius	TJ	Tajikistan
BN	Brunei Darussalam	GW	Guinea-Bissau	MV	Maldives	TK	Tokelau
BO	Bolivia	GY	Guyana	MW	Malawi	TM	Turkmenistan
BR	Brazil	HK	Hong Kong	MX	Mexico	TN	Tunisia
BS	Bahamas	HM	Heard Island and McDonald Islands	MY	Malaysia	TO	Tonga
BT	Bhutan	HN	Honduras	MZ	Mozambique	TP	East Timor
BV	Bouvet Island	HR	Croatia	NA	Namibia	TR	Turkey
BW	Botswana	HT	Haiti	NC	New Caledonia	TT	Trinidad and Tobago
BY	Belarus	HU	Hungary	NE	Niger	TV	Tuvalu
BZ	Belize	ID	Indonesia	NF	Norfolk Island	TW	Taiwan
CA	Canada	IE	Ireland	NG	Nigeria	TZ	Tanzania, United Republic of
CC	Cocos (Keeling) Islands	IN	India	NI	Nicaragua	UA	Ukraine
CF	Central African Republic	IO	British Indian Ocean Territory	NL	Netherlands	UG	Uganda
CG	Congo	IQ	Iraq	NO	Norway	UM	United States Minor Outlying Islands
CH	Switzerland	IR	Iran (Islamic Republic of)	NP	Nepal	US	United States
CI	Côte d'Ivoire	IS	Iceland	NR	Nauru	UY	Uruguay
CK	Cook Islands	IT	Italy	NU	Niue	UZ	Uzbekistan
CL	Chile	JM	Jamaica	NZ	New Zealand	VA	Vatican City State (Holy See)
CM	Cameroon	JO	Jordan	OM	Oman	VC	Saint Vincent and the Grenadines
CN	China	JP	Japan	PA	Panama	VE	Venezuela
CO	Colombia	KE	Kenya	PE	Peru	VG	Virgin Islands (British)
CR	Costa Rica	KG	Kyrgyzstan	PF	French Polynesia	VI	Virgin Islands (U.S.)
CU	Cuba	KH	Kambodia	PG	Papua New Guinea	VN	Viet Nam
CV	Cape Verde	KI	Kiribati	PH	Philippines	VU	Vanuatu
CX	Christmas Island	KM	Comoros	PK	Pakistan	WF	Wallis and Futuna Islands
CY	Cyprus	KN	Saint Kitts and Nevis	PL	Poland	WS	Samoa
CZ	Czech Republic	KP	Korea, Democratic People's Republic of	PM	Saint Pierre and Miquelon	YE	Yemen
DE	Germany	KR	Korea, Republic of	PN	Pitcairn	YT	Mayotte
DJ	Djibouti	KW	Kuwait	PR	Puerto Rico	YU	Yugoslavia
DK	Denmark	KY	Cayman Islands	PT	Portugal	ZA	South Africa
DM	Dominica	KZ	Kazakhstan	PW	Palau	ZM	Zambia
DO	Dominican Republic			PY	Paraguay	ZR	Zaire
DZ	Algeria			QA	Qatar	ZW	Zimbabwe
EC	Ecuador			RE	Réunion		
EE	Estonia			RO	Romania		
EG	Egypt			RU	Russian Federation		
EH	Western Sahara						

Aspect ratio

The ratio of vertical and horizontal sizes of a displayed image. The horizontal vs. vertical ratio of conventional TVs is 4:3 and that of wide-screen TVs is 16:9.

Chapter

The smallest division on DVD VIDEO. It is a division of a title and similar to a track for CD or VCD.

Component video signal

A video signal system where parts of information necessary for reproducing image signal comprised of the three primary colors of light are transmitted via separate signal lines. Types of signal, such as R/G/B, Y/Pb/Pr, etc., are available.

Composite video signal

A video signal comprised of three kinds of signals combined: an image signal made up of luminance and chrominance signals using the frequency multiplication technique, burst signal providing the basis for color reproduction, and synchronization signal.

Disc menu

A screen display prepared for allowing selection of images, sounds, subtitles, multi-angle, etc. recorded on DVD VIDEO.

Interlaced scanning

In the conventional video system, a picture is shown on the display monitor in two halves. The Interlaced scanning system places lines of the second half of the picture in-between lines of the first half of the picture.

JPEG

A still-picture data compression system proposed by the Joint Photographic Expert Group, which features little distortion in image quality in spite of its high compression ratio.

Letter box

A method of displaying wide images like movies in on a 4:3 TV screen with no part of the image deleted by placing black bands on the top and bottom of the screen. This name has derived from the screen form looking literally like a letter box.

Linear PCM (PCM: Pulse Code Modulation)

A system for converting analog sound signal to digital signal for later processing with no data compression used in conversion.

MP3

A file format with a sound data compression system. "MP3" is the abbreviation of Motion Picture Experts Group 1 (or MPEG-1) Audio Layer 3. By using MP3 format, one CD-R or CD-RW can contain about 10 times as much data volume as a regular CD can.

Multi-angle

By recording multiple scenes progressing at the same time in a single title, the user can select view angles. This feature is called the multi-angle function.

Multi-channel

DVD VIDEO has been designed to have each soundtrack constitute one sound field. Multi-channel refers to a structure of sound tracks having three or more channels.

Multilanguage

When a title is created to cope with multiple languages, it is generally called a multilanguage title.

Packed PCM (PCM: Pulse Code Modulation)

A format for DVD AUDIO with a compression ratio of about 2:1. This supports up to 192 kHz/24 bit and allows PCM signals to be completely recreated.

Parental Lock

A feature of this system to automatically determine whether or not to reproduce particular DVD VIDEO software by comparing its parental level (a measure of undesirability of scenes, etc. from educational viewpoint) set for the software beforehand with that set on this system by the user; if the software's level is less restrictive than the user-set level, it will be reproduced.

Playback control (PBC)

Refers to the signal recorded on VCD/SVCD for controlling reproduction. By using menu screens recorded on VCD/SVCD that supports PBC, you can enjoy interactive-type software as well as software having a search function.

Progressive scanning

By progressive scanning, all the horizontal lines of a picture are displayed at one time as a single frame. This system can convert the interlaced video from DVD VIDEO into progressive format for connection to a progressive TV. It dramatically increases the vertical resolution.

Region code

A system for allowing discs to be played back only in the regions designated beforehand. All the countries in the world are divided into six regions and each region is identified by a specified region code (or region number). If the region code of a disc matches that of a player, the player can play back the disc.

Sampling frequency

Frequency of sampling data when analog data is converted to digital data. Sampling frequency numerically represents how many times the original analog signal is sampled per second.

Surround

A system for creating three-dimensional sound fields full of realism by arranging multiple speakers around the listener.

Transfer rate

The rate of transferring digital data. Usually the measure is in bit per second (bps). The DVD system applies a variable transfer rate system for high efficiency.

AV COMPU LINK Remote Control System

The AV COMPU LINK remote control system allows you to operate JVC's video components (TV and VCR) through the unit.

This unit is equipped with the AV COMPU LINK-III, which has added a function to operate JVC's video components through the video components terminals. To use this remote control system, you need to connect the video components you want to operate, following the diagrams below and the procedures on page 62.

- Refer also to the manuals supplied with your video components.

CONNECTIONS 1: AV COMPU LINK Connection

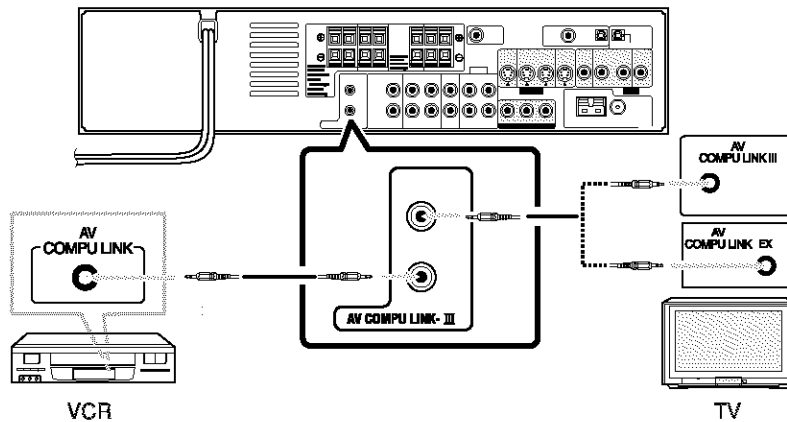

CAUTION:

When connecting the TV with the AV COMPU LINK remote control system, connect the unit to the AV COMPU LINK III or AV COMPU LINK EX terminal. DO NOT connect the unit to the AV COMPU LINK RECEIVER/AMP terminal.

Notes:

- When connecting the unit and a TV with the AV COMPU LINK EX terminal by using a component video cable, you cannot use Automatic Selection of TV's Input Mode (see page 62).
- When connecting the VCR only to this unit, connect it directly to the unit using cables with monaural mini-plugs.

CONNECTIONS 2: Video Cable Connection

This unit is equipped with three types of the video terminals—composite video, S-video, and component video, and the signals coming into this unit through one type of video terminals can output only through the terminal of the same type. So you need to connect the VCR and TV to this unit using one of the following two ways—CASE 1 or 2:

- When using the AV COMPU LINK remote control system, set the component video input correctly (see "Video output mode" on page 25); otherwise, the correct input for this unit will not be selected on the TV.

<p>CASE 1</p>	<p>When connecting the source equipment to the unit through the S-video terminals, connect this unit to the TV's Video Input 1 terminal using S-video cables.</p> <div style="text-align: center;"> <p>Source Equipment — S-video cable — RX-DV31SL — S-video cable — TV To Video Input 1</p> </div>
<p>CASE 2</p>	<p>When connecting the source equipment to the unit through the composite video terminals, connect this unit to the TV's Video Input 2 terminal (composite video input) using composite video cables.</p> <div style="text-align: center;"> <p>Source Equipment — Composite video cable — RX-DV31SL — Composite video cable — TV To Video Input 2</p> </div>
<p>CASE 3</p>	<p>When setting the video output mode of the built-in DVD player to "component," connect this unit to the TV's Video Input 2 terminals (component video input) using component video cables.</p> <div style="text-align: center;"> <p>RX-DV31SL — Component video cable — TV To Video Input 2</p> </div>

- 1** If you have already plugged your VCR, TV, and this unit into the AC outlets, unplug their AC power cords first.
- 2** Connect your VCR, TV, and this unit following "CONNECTIONS 1" on the previous page, using cables with monaural mini-plugs (not supplied).
- 3** Connect the audio input/output jacks on VCR, TV, and this unit using the audio cords.
 - See pages 9 and 10.
- 4** Connect the video input/output jacks on VCR, TV and this unit following "CONNECTIONS 2" on the previous page, using the composite video cord, with S-video plug or with component video plugs.
- 5** Plug the AC power cords of the components into the AC outlets.
- 6** When turning on the TV for the first time after the AV COMPU LINK connection, turn the TV volume to the minimum using the TV volume control on the TV.
- 7** Turn on other connected components first, then turn on this unit.
 - When turning on the VCR, use the remote control supplied with this unit—press VCR \odot /I.

The AV COMPU LINK remote control system allows you to use the five basic functions listed below.

Remote control of the TV and VCR using this remote control

For details, see page 64.

- Aim the remote control directly at the remote sensor on each target component.

One-touch video play

Simply by inserting a video cassette without its safety tab into the VCR, you can enjoy the video playback without setting other switches manually. The unit automatically turns on and changes the source to VCR.

The TV automatically turns on and changes the input mode to the appropriate position so that you can view the playback picture.

When you insert a video cassette with its safety tab, press the play (\blacktriangleright) button on the VCR or on the remote control. You can get the same result.

One-touch DVD play

Simply by starting playback on the built-in DVD player, you can enjoy the playback without setting other switches manually.

The TV automatically turns on and changes the input mode to the appropriate position so that you can view the playback picture.

Automatic selection of TV's input mode

- When you select TV as the source to play on the unit, the TV automatically changes the input mode to the TV tuner so that you can watch TV.
- When you select DVD, VCR, or DBS as the source to play on the unit, the TV automatically changes the input mode to the appropriate position so that you can view the playback picture.

Notes:

- *When connecting a TV with the AV COMPU LINK EX terminal to this unit, you cannot use a component video cable (as CASE 3 on the previous page).*
- *When you select TV as the source on the unit, you cannot see the menu on the TV screen since the AV COMPU LINK remote control system automatically changes the TV's input mode to the TV tuner. If you do not mind stopping listening to the TV sounds, you can then show the on-screen menu after changing the TV's input mode to the appropriate position the unit is connected to.*

Automatic power on/off

The TV and VCR turn on and off along with the unit.

When you turn on the unit;

- If the previously selected source is VCR, the TV and VCR will turn on automatically.
- If the previously selected source is TV or DVD, only the TV will turn on automatically.

When you turn off the unit, the TV and VCR will turn off.

Note:

- *If you turn off the unit while recording on the VCR, the VCR will not turn off, but continue recording.*

Operating JVC's Audio/Video Components

You can operate JVC's audio and video components with this unit's remote control, since control signals for JVC's components are preset in the remote control.

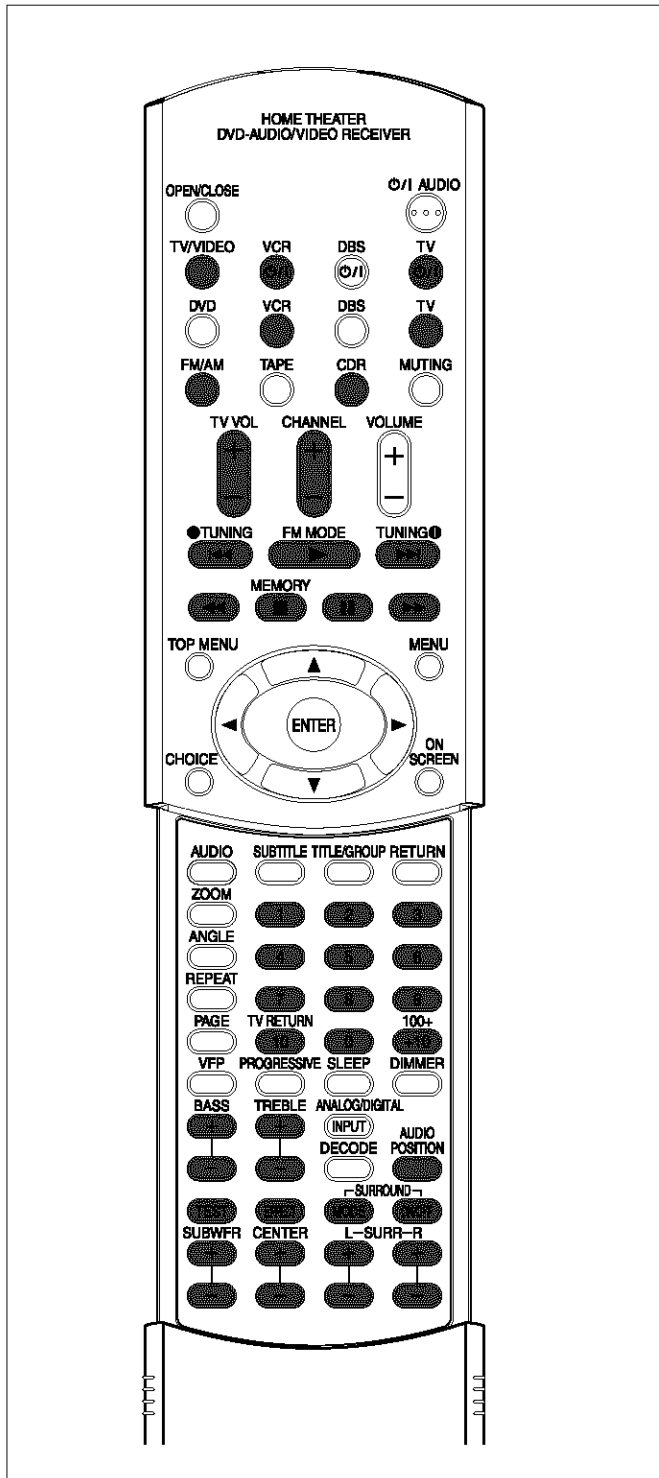

Operating Audio Components

To operate JVC's audio components using this remote control:

- Aim the remote control directly at the remote sensor on the unit.
- To operate a source with the remote control, the source must be selected using the source selecting buttons on the remote control.
- Refer also to the manuals supplied with your components.

■ Sound control section (Amplifier)

You can perform the following operations:

BASS + or -	Adjusts the bass sound.
TREBLE + or -	Adjusts the treble sound.
AUDIO POSITION	Adjusts the subwoofer audio position.
SURROUND ON/OFF	Turns on or off the Surround modes—Dolby Digital, DTS Digital Surround, and Dolby Pro Logic II.
SURROUND MODE	Selects the Surround modes.
TEST	Turns on or off the test tone output.
CENTER + or -	Adjusts the center speaker channel output level.
SURR L + or -	Adjusts the left surround speaker channel output level.
SURR R + or -	Adjusts the right surround speaker channel output level.
SUBWFR + or -	Adjusts subwoofer channel output level.
EFFECT	Selects the effect level.

■ CD recorder

After pressing CDR, you can perform the following operations on a CD player and a CD recorder:

▶	Starts playing.
◀◀	Returns to the beginning of the current (or previous) track.
▶▶	Skips to the beginning of the next track.
■	Stops playing.
	Pauses playing. To release it, press ▶.
1 – 10, +10	Selects a track number directly. For track number 5, press 5. For track number 15, press +10, then 5. For track number 20, press +10, then 10. For track number 30, press +10, +10, then 10.

Note:

- When you start recording on the CD recorder, use the buttons on the CD recorder itself or on the remote control supplied with it.

■ Tuner

You can always perform the following operations:

FM/AM	Tunes into the last selected FM or AM station.
--------------	--

- Each time you press the button, the band alternates between FM and AM.

After pressing FM/AM, you can perform the following operations on a tuner:

1 – 10, +10	Selects a preset channel number directly. For channel number 5, press 5. For channel number 15, press +10, then 5. For channel number 20, press +10, then 10.
TUNING ⊕ or ⊖	Tunes in to stations.
FM MODE	Changes the FM reception mode.

Operating Video Components

To operate JVC's video components using this remote control

- You need to connect JVC's video components through the AV COMPU LINK-III jacks (see page 61) in addition to the audio/video connections (see pages 9 to 11).
- Some JVC's VCRs can accept two types of the control signals—remote codes "A" and "B." Before using this remote control, make sure that the remote control code of the connected VCR is set to code "A."
- To operate the video component(s) using the remote control, aim the remote control directly at the remote sensor on each component, not on this unit.

■ TV

You can always perform the following operations:

TV ⏻/⏷	Turns on or off the TV.
TV VOL +/-	Adjusts the volume.
TV/VIDEO	Sets the input mode (either TV or VIDEO).

After pressing TV, you can perform the following operations on a TV:

CHANNEL +/-	Changes the channels.
1 – 9, 0, 100+	Selects the channels. For channel number 5, press 5. For channel number 10, press 1, then 0. For channel number 23, press 2, then 3. For channel number 135, press 100+, 3, then 5.
TV RETURN	Alternates between the previously selected channel and the current channel.

■ VCR

You can always perform the following operations:

VCR ⏻/⏷	Turns on or off the VCR.
----------------	--------------------------

After pressing VCR, you can perform the following operations on a VCR:

1 – 9, 0	Selects the TV channels on a VCR. For channel number 5, press 5. For channel number 10, press 1, then 0. For channel number 23, press 2, then 3.
▶	Starts playing.
◀◀	Rewinds a tape.
▶▶	Fast-winds a tape.
■	Stops playing.
	Pauses playing. To release it, press ▶.

Operating Other Manufacturers' Equipment

The remote control supplied with this unit can transmit control signals for other manufacturers' TVs, DBS tuners, and VCRs. By changing the transmittable signals from preset ones to the other manufacturers' signals, you can operate other manufacturers' components using this remote control.

Changing the Preset Signal Codes

To operate other manufacturers' components using this remote control:

- Aim the remote control directly at the remote sensor on each equipment.
- To operate a source with the remote control, the source must be selected using source selecting buttons on the remote control.
- Refer also to the manuals supplied with your equipment.

To change the transmittable signals for operating other manufacturers' TV

- 1 Press and hold TV ϕ /I.
- 2 Press TV.
- 3 Enter the manufacturer's code using the number buttons (1 – 9, 0).
See the table on the right to find the code.
- 4 Release TV ϕ /I.

You can always perform the following operations:

TV ϕ/I	Turns on or off the TV.
TV VOL +/-	Adjusts the volume.
TV/VIDEO	Sets the input mode (either TV or VIDEO).

After pressing TV, you can perform the following operations on a TV:

CHANNEL +/-	Changes the channels.
1 – 9, 0, 100+	Selects the channels. For channel number 5, press 5. For channel number 10, press 1, then 0. For channel number 23, press 2, then 3. For channel number 135, press 100+, 3, then 5. <ul style="list-style-type: none">• TV RETURN will function as the ENTER button if your equipment requires pressing ENTER after selecting a channel number.

Notes:

- Refer also to the manual supplied for your TV.
- Not all of the functions listed on the left may be assigned to specific buttons for some TVs.
- If you cannot change the channels of some TVs by pressing the number buttons, press CHANNEL + or – for changing the channels.

5 Try to operate your TV by pressing TV ϕ /I.

When your TV turns on or off, you have entered the correct code.

If there is more than one code listed for your brand of TV, try each one until the correct one is entered.

Manufacturers' codes for TV

Manufacturer	Codes
JVC	01*
Akai	02
Bell & Howell	03
Centurion	04
Coronad	05
Daewoo	06 – 08
Emerson	09 – 13
Fisher	14
GE	15, 16, 17
Goldstar	18, 19
Hitachi	20, 21
KTV	22, 23
Magnavox	24
Marantz	25
Mitsubishi	25
Panasonic	26, 27
Philips	24
Pioneer	28
Proscan	29
Quasar	30
RadioShack	31
RCA	02, 17, 32 – 35
Samsung	36, 37
Sanyo	14
Sears	38
Sharp	39
Sony	40
Symphonic	41, 42
Toshiba	38
Zenith	43, 44

* "01" is the initial code.

Note:

- Manufacturers' codes are subject to change without notice. If they are changed, this remote control cannot operate the equipment.

To change the transmittable signals for operating other manufacturers' DBS tuner

- 1 Press and hold DBS** ϕ /I.
- 2 Press DBS.**
- 3 Enter the manufacturer's code using the number buttons (1 – 9, 0).**
See the table on the right to find the code.
- 4 Release DBS** ϕ /I.

You can always perform the following operation:

DBS ϕ /I	Turns on or off the DBS tuner.
----------------------	--------------------------------

After pressing DBS, you can perform the following operations on the DBS tuner:

CHANNEL +/-	Changes the channels.
1 – 9, 0, 100+	Selects the channels. For channel number 5, press 5. For channel number 10, press 1, then 0. For channel number 23, press 2, then 3. For channel number 135, press 100+, 3, then 5. <ul style="list-style-type: none">• TV RETURN will function as the ENTER button if your equipment requires pressing ENTER after selecting a channel number.

Note:

- Refer also to the manual supplied for your DBS tuner.

5 Try to operate your DBS tuner by pressing DBS ϕ /I.

When your DBS tuner turns on or off, you have entered the correct code.

If there is more than one code listed for your brand of DBS tuner, try each one until the correct one is entered.

Manufacturers' codes for DBS tuner

Manufacturer	Codes
Echostar	40
Gemini	02
General Instrument	01*, 41
Hamlin	03 – 06
Hitachi	42
Hughes	43
Jerrold	07 – 15
Macom	16 – 18
Magnavox	19
Oak	20 – 22
Panasonic	23, 24, 44
Philips	25 – 30
Pioneer	31, 32
Primestar	45
RCA	46
Samsung	36
Scientific Atlanta	33 – 35
Sony	47
Tocom	37
Toshiba	48
Zenith	38, 39

* "01" is the initial code.

Note:

- Manufacturers' codes are subject to change without notice. If they are changed, this remote control cannot operate the equipment.

Operating Other Manufacturers' Equipment

To change the transmittable signals for operating other manufacturers' VCR

- 1** Press and hold VCR ϕ /I.
- 2** Press VCR.
- 3** Enter the manufacturer's code using the number buttons (1 – 9, 0).
See the table on the right to find the code.
- 4** Release VCR ϕ /I.

You can always perform the following operation:

VCR ϕ /I	Turns on or off the VCR.
----------------------	--------------------------

After pressing VCR, you can perform the following operations on a VCR:

1 – 9, 0	Selects the TV channels on a VCR. For channel number 5, press 5. For channel number 10, press 1, then 0. For channel number 23, press 2, then 3. • TV RETURN will function as the ENTER button if your equipment requires pressing ENTER after selecting a channel number.
▶	Starts playing.
◀◀	Rewinds a tape.
▶▶	Fast-winds a tape.
■	Stops playing.
 	Pauses playing. To release, press ▶.

Note:

- Refer also to the manual supplied for your VCR.

5 Try to operate your VCR by pressing VCR ϕ /I.

When your VCR turns on or off, you have entered the correct code.

If there is more than one code listed for your brand of VCR, try each one until the correct one is entered.

Manufacturers' codes for VCR

Manufacturer	Codes
JVC	01* – 04
Aiwa	05
Akai	06 – 08
Bell & Howell	09
Daewoo	10
Emerson	11 – 15
Fisher	16 – 19
GE	20, 21
Go Video	22, 24, 25
Goldstar	23
Hitachi	20, 26
Magnavox	27 – 29
Mitsubishi	30 – 33
NEC	34, 35
Panasonic	36, 37
Philips	27
RCA	38
Samsung	39 – 41
Sanyo	16 – 19
Scott	42
Sharp	43, 44
Shintom	45
Sony	46 – 51
Symphonic	52
Teknica	53, 54
Toshiba	55
Zenith	56

* "01" is the initial JVC code.

Note:

- Manufacturers' codes are subject to change without notice. If they are changed, this remote control cannot operate the equipment.

To get the best performance from the system, keep your discs and mechanism clean.

General Notes

In general, you will have the best performance by keeping your discs and mechanism clean.

- Store discs in their cases, and keep them in cabinets or on shelves.

Handling Discs

- Remove the disc from its case by holding it at the edge while pressing the center hole lightly.
- Do not touch the shiny surface of the disc, or bend the disc.
- Put the disc back in its case after use to prevent warping.



- Be careful not to scratch the surface of the disc when placing it back in its case.
- Avoid exposure to direct sunlight, temperature extremes, and moisture.

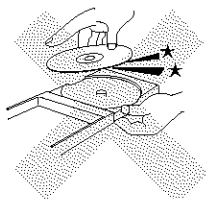

Cleaning Discs

Wipe the disc with a soft cloth in a straight line from center to edge.



DO NOT use any solvent—such as conventional record cleaner, spray, thinner, or benzine—to clean the disc.

Cleaning the Unit

- Stains on the unit
Should be wiped off with a soft cloth. If the unit is heavily stained, wipe it with a cloth soaked in water-diluted neutral detergent and wrung well, then wipe clean with a dry cloth.
- Since the unit may deteriorate in quality, become damaged or have its paint peeled off, be careful about the following.
 - DO NOT wipe it with a hard cloth.
 - DO NOT wipe it strong.
 - DO NOT wipe it with thinner or benzine.
 - DO NOT apply any volatile substances such as insecticides to it.
 - DO NOT allow any rubber or plastic to remain in contact with it for a long time.

Troubleshooting

Use this chart to help you solve daily operational problems. If there is any problem you cannot solve, contact your JVC's service center.

■ General

PROBLEM	POSSIBLE CAUSE	SOLUTION
The power does not come on.	The power cord is not plugged in.	Plug the power cord into an AC outlet.
No sound from speakers.	Speaker signal cables are not connected.	Check speaker wiring and reconnect if necessary.
	The audio cable is not connected properly.	Connect the cord properly (see pages 9 to 11).
	An incorrect source is selected.	Select the correct source.
	Muting is activated.	Press MUTING on the remote control to cancel the muting.
Sound from one speaker only.	An incorrect input mode (analog or digital) is selected.	Select the correct input mode (analog or digital).
	Connections are incorrect.	Check connections.
"OVERLOAD" starts flashing on the display.	The balance is set to one extreme.	Adjust the balance properly (see pages 26 or 54).
	Speakers are overloaded because of high volume.	<ol style="list-style-type: none"> 1. Press ϕ/I STANDBY/ON on the front panel to turn off the unit. 2. Stop the playback source. 3. Turn on the unit again, and adjust the volume.
The STANDBY lamp lights up after turning on the power, but soon the unit turns off (into standby mode).	Speakers are overloaded because of short circuit of speaker terminals.	Press ϕ /I STANDBY/ON on the front panel to turn off the unit, then check the speaker wiring. If "OVERLOAD" does not disappear, unplug the AC power cord, then plug it back again. If speaker wiring is not short-circuited, contact your dealer.
	The unit is overloaded because of a high voltage.	Press ϕ /I STANDBY/ON on the front panel to turn off the unit. After unplugging the power cord, consult your dealer.
Remote control does not operate as you intend.	The remote control is not ready for your intended operation.	Press a source selecting button first, then press the buttons you want to use.
Remote control does not work.	It is too far from the unit, or is not facing the unit.	Come closer to the unit. Operate the remote control within 7 m (23 ft) from the unit.
	There is an obstruction hiding the remote sensor on the unit.	Remove the obstruction.
	The remote control is not aimed at the remote sensor on the unit or components.	Aim the remote control at the remote sensor on each component you want to operate.
	The batteries have been inserted into the wrong way round (+/-).	Insert the batteries correctly.
	Batteries are weak.	Replace batteries.
	The remote control signals are not set correctly.	Enter the correct manufacturers' code (see pages 65 to 67).

■ For DVD Player

PROBLEM	POSSIBLE CAUSE	SOLUTION
No picture is displayed on the TV.	The video cord is not connected correctly.	Connect the cord correctly (see pages 9 and 10).
	TV input selection is incorrect.	Select the correct input on the TV.
	The disc is not playable.	Replace the disc (see page 32).
No picture is displayed on the TV screen, the picture is blurred, or the picture is divided into two parts.	The scanning mode is set to "PROGRESSIVE" though the unit is connected to a TV which does not support progressive video input, such as a conventional TV.	Change the scanning mode to "INTERLACE" (see page 16).
No sound is heard and "NO AUDIO" appears on the display.	The loaded disc may be illegally copied.	Consult with the disc vendor.
A disc cannot be played.	The unit's and disc's Region Code numbers are incompatible.	Replace the disc (see page 32).
	Parental Lock is in use.	Enter your password to change the parental level (see page 58).
A disc cannot be played and "0:00" appears on the display.	The disc is loaded with its label and data sides inverted.	Insert the disc correctly (see page 17).
	An unplayable disc is loaded.	Replace the disc (see page 32).
Video and audio are distorted.	The disc is scratched or dirty.	Replace or clean the disc (see page 68).
	A VCR is connected between the unit and the TV.	Connect the unit and TV directly.
	With some discs, a picture may be blurred when setting "PICTURE SOURCE" to "FILM" or "AUTO."	Set "PICTURE SOURCE" to "VIDEO (NORMAL)" or "VIDEO (ACTIVE)" (see page 53).
"MULTI CH" or "L/R ONLY" appears on the display.	The current track prohibits you from playing back with stereo sound.	Activate Surround mode (see page 30) or listen to another track.
The picture does not fit the TV screen properly.	"MONITOR TYPE" is not set correctly.	Set the monitor type correctly (see page 53).
	The TV is not set correctly.	Set the TV correctly.
One-touch DVD playback does not work though you have connected AV COMPU LINK cord correctly.	The video output mode setting is incorrect.	Set the video output mode correctly according to the video connection between your TV and the unit (see page 25).
No subtitle appears on the TV screen though you have selected your initial subtitle language.		Some discs are programmed to always display no subtitle initially. If this happens, press SUBTITLE on the remote control after starting play (see page 37).
Audio language is different from the one you have selected as your initial audio language.		Some discs are programmed to always use the original language initially. If this happens, press AUDIO on the remote control after starting play (see page 38).

■ For Tuner

PROBLEM	POSSIBLE CAUSE	SOLUTION
Hard to listen to broadcast because of noise.	The AM loop antenna is too close to the unit.	Change the position and direction of the AM loop antenna.
	The supplied FM antenna is not properly extended and positioned.	Extend the FM antenna at the best position.
Continuous hiss or buzzing during FM reception.	Incoming signal is too weak.	Connect an outdoor FM antenna or contact your dealer.
	The station is too far away.	Select a new station.
	An incorrect antenna is used.	Check with your dealer to be sure you have the correct antenna.
	Antennas are not connected properly.	Check connections.
Occasional cracking noise during FM reception.	Ignition noise from automobiles.	Move the antenna farther from automobile traffic.

■ For MP3

PROBLEM	POSSIBLE CAUSE	SOLUTION
A disc cannot be played.	No MP3 files are recorded on the disc.	Replace the disc.
	The disc is unplayable (such as CD-ROM).	
	MP3 files do not have the correct file extension—.mp3, .Mp3, .mP3, or .MP3—in their file names.	Add the file extension—.mp3, .Mp3, .mP3, or .MP3—to their file names (see page 47).
	MP3 files are made at bit rate under 64 kbps.	This unit cannot play back such files. Replace the disc.
	MP3 files are not recorded in a format compliant with ISO 9660 Level 1 or 2.	Replace the disc. (Record MP3 files using a compliant application.)
No MP3 files, only JPEG files are played.	The MP3/JPEG setting is set to "JPEG."	When both MP3 files and JPEG files are recorded on a disc, to play MP3 files, set the MP3/JPEG setting to "MP3" (see page 54).

■ For JPEG

PROBLEM	POSSIBLE CAUSE	SOLUTION
A disc cannot be played.	No JPEG files are recorded on the disc.	Replace the disc.
	The disc is unplayable (such as CD-ROM).	
	JPEG files do not have the correct file extension in their file names.	Add the file extension—.jpg, .jpeg, .JPG, .JPEG or any uppercase and lowercase combination (such as ".Jpg")—to their file names (see page 49).
	JPEG files are not made with baseline JPEG format.	This unit cannot play back such files. Replace the disc.
	JPEG files are not recorded in a format compliant with ISO 9660 Level 1 or 2.	Replace the disc. (Record JPEG files using a compliant application.)
No JPEG files, only MP3 files are played.	The MP3/JPEG setting is set to "MP3."	When both MP3 files and JPEG files are recorded on a disc, to play JPEG files, set the MP3/JPEG setting to "JPEG" (see page 54).

Amplifier

Output Power	At Stereo operation: Front channels: 100 W per channel, min. RMS, driven into 8 Ω, 40 Hz to 20 kHz with no more than 0.8% total harmonic distortion. At Surround operation: Front channels: 100 W per channel, min. RMS, driven into 8 Ω at 1 kHz, with no more than 0.8% total harmonic distortion. Center channel: 100 W, min. RMS, driven into 8 Ω at 1 kHz, with no more than 0.8% total harmonic distortion. Surround channels: 100 W per channel, min. RMS, driven into 8 Ω at 1 kHz, with no more than 0.8% total harmonic distortion.
--------------	---

Audio

Audio Input Sensitivity/Impedance (1 kHz):	TV, TAPE/CDR, DBS, VCR:	240 mV/47 kΩ
Audio Input (DIGITAL IN)* :	Coaxial: DIGITAL 1 (DBS):	0.5 V(p-p)/75 Ω
	Optical: DIGITAL 2 (TV):	-21 dBm to -15 dBm (660 nm ±30 nm)
Signal-to-Noise Ratio (*66 IHF/78 IHF):	TV, TAPE/CDR, DBS, VCR:	87 dB/67 dB
Frequency Response (8 Ω):	TV, TAPE/CDR, DBS, VCR:	20 Hz to 20 kHz (±1 dB)
Tone Control:	Bass (100 Hz):	±10 dB ±2 dB
	Treble (10 kHz):	±10 dB ±2 dB

* Corresponding to Linear PCM, Dolby Digital, and DTS Digital Surround (with sampling frequency—32 kHz, 44.1 kHz, 48 kHz).

Video

Video Input Sensitivity/Impedance (1 kHz):		
Composite video:	DBS IN, VCR IN:	1 V(p-p)/75 Ω
S-video:	DBS IN, VCR IN: (Y:luminance):	1 V(p-p)/75 Ω
	(C:chrominance):	0.286 V(p-p)/75 Ω
Video Output Level/Impedance (1 kHz):		
Composite video:	VCR OUT, MONITOR OUT:	1 V(p-p)/75 Ω
S-video:	VCR OUT, MONITOR OUT: (Y:luminance):	1 V(p-p)/75 Ω
	(C:chrominance):	0.286 V(p-p)/75 Ω
Component video:	DVD COMPONENT VIDEO OUT: (Component-Y):	1.0 V(p-p)/75 Ω
	(Component-Pb/Pa):	0.7 V(p-p)/75 Ω
Color System:	NTSC	
Horizontal Resolution:	500 lines	
Signal-to-Noise Ratio (S/N):	63 dB	
Synchronize:	Negative	

FM tuner (IHF)

Tuning Range:	87.5 MHz to 108.0 MHz
---------------	-----------------------

AM tuner

Tuning Range:	530 kHz to 1 710 kHz
---------------	----------------------

General

Power Requirements:	AC 120 V ~ , 60 Hz
Power Consumption:	200 W/255 VA (in operation) 2 W (in standby mode)
Dimensions (W x H x D):	435 mm x 100 mm x 403.5 mm (17 3/16 in. x 3 15/16 in. x 15 15/16 in.)
Mass:	8.4 kg (18.5 lbs)



LIMITED WARRANTY

CONSUMER VIDEO 1-90

JVC COMPANY OF AMERICA warrants this product and all parts thereof, except as set forth below **ONLY TO THE ORIGINAL PURCHASER AT RETAIL** to be **FREE FROM DEFECTIVE MATERIALS AND WORKMANSHIP** from the date of original retail purchase for the period as shown below. ("The Warranty Period")

PARTS	1 YR	LABOR	90 DAYS
-------	-------------	-------	----------------

THIS LIMITED WARRANTY IS VALID ONLY IN THE FIFTY (50) UNITED STATES, THE DISTRICT OF COLUMBIA AND IN COMMONWEALTH OF PUERTO RICO.

WHAT WE WILL DO:

If this product is found to be defective, JVC will repair or replace defective parts at no charge to the original owner. Such repair and replacement services shall be rendered by JVC during normal business hours at JVC authorized service centers. Parts used for replacement are warranted only for the remainder of the Warranty Period. All products and parts thereof may be brought to a JVC authorized service center on a carry-in basis except for Television sets having a screen size 25 inches and above which are covered on an in-home basis.

WHAT YOU MUST DO FOR WARRANTY SERVICE:

Return your product to a JVC authorized service center with a copy of your bill of sale. For your nearest JVC authorized service center, please call toll free: (800) 537-5722.

If service is not available locally, box the product carefully, preferably in the original carton, and ship, insured, with a copy of your bill of sale plus a letter of explanation of the problem to the nearest JVC Factory Service Center, the name and location of which will be given to you by the toll-free number.

If you have any questions concerning your JVC Product, please contact our Customer Relations Department.

WHAT IS NOT COVERED:

This limited warranty provided by JVC does not cover:

1. Products which have been subject to abuse, accident, alteration, modification, tampering, negligence, misuse, faulty installation, lack of reasonable care, or if repaired or serviced by anyone other than a service facility authorized by JVC to render such service, or if affixed to any attachment not provided with the products, or if the model number or serial number has been altered, tampered with, defaced or removed;
2. Initial installation and installation and removal for repair;
3. Operational adjustments covered in the Owner's Manual, normal maintenance, video and audio head cleaning;
4. Damage that occurs in shipment, due to act of God, and cosmetic damage;
5. Signal reception problems and failures due to line power surge;
6. Video Pick-up Tubes/CCD Image Sensor, Cartridge, Stylus (Needle) are covered for 90 days from the date of purchase;
7. Accessories;
8. Batteries (except that Rechargeable Batteries are covered for 90 days from the date of purchase);

There are no express warranties except as listed above.

THE DURATION OF ANY IMPLIED WARRANTIES, INCLUDING THE IMPLIED WARRANTY OF MERCHANTABILITY, IS LIMITED TO THE DURATION OF THE EXPRESS WARRANTY HEREIN.

JVC SHALL NOT BE LIABLE FOR THE LOSS OF USE OF THE PRODUCT, INCONVENIENCE, LOSS OR ANY OTHER DAMAGES, WHETHER DIRECT, INCIDENTAL OR CONSEQUENTIAL (INCLUDING, WITHOUT LIMITATION, DAMAGE TO TAPES, RECORDS OR DISCS) RESULTING FROM THE USE OF THIS PRODUCT, OR ARISING OUT OF ANY BREACH OF THIS WARRANTY. ALL EXPRESS AND IMPLIED WARRANTIES, INCLUDING THE WARRANTIES OF MERCHANTABILITY AND FITNESS FOR PARTICULAR PURPOSE, ARE LIMITED TO THE WARRANTY PERIOD SET FORTH ABOVE.

Some states do not allow the exclusion of incidental or consequential damages or limitations on how long an implied warranty lasts, so these limitations or exclusions may not apply to you. This warranty gives you specific legal rights and you may also have other rights which vary from state to state.

JVC COMPANY OF AMERICA	1700 Valley Road
DIVISION OF JVC AMERICAS CORP.	Wayne, NJ 07470

REFURBISHED PRODUCTS CARRY A SEPARATE WARRANTY, THIS WARRANTY DOES NOT APPLY. FOR DETAILS OF REFURBISHED PRODUCT WARRANTY, PLEASE REFER TO THE REFURBISHED PRODUCT WARRANTY INFORMATION PACKAGED WITH EACH REFURBISHED PRODUCT.

For customer use:

Enter below the Model No. which is located either on the rear, bottom or side of the cabinet. Retain this information for future reference.

Model No. : _____	Serial No. : _____
Purchase date : _____	Name of dealer : _____

Authorized Service Centers

QUALITY **JVC**[®] SERVICE

HOW TO LOCATE YOUR JVC SERVICE CENTER

TOLL FREE: 1 (800) 537-5722

<http://www.jvc.com>

Dear Customer,

In order to receive the most satisfaction from your purchase, please read the instruction booklet before operating the unit. In the event that repairs are necessary, please call 1 (800)537-5722 for your nearest authorized servicer or visit our website at **www.JVC.com**

Remember to retain your Bill of Sale for Warranty Service.

Do not service the television yourself

Caution

To prevent electrical shock, do not open the cabinet. There are no user serviceable parts inside.

Please refer to qualified service personnel for repairs.

Accessories

To purchase accessories for your JVC product, please call toll free: 1 (800)882-2345 or on the web at **www.JVC.com**

RX-DV31SL

HOME THEATER DVD-AUDIO/VIDEO RECEIVER

