

ENGLISH

Digital Video Camcorder

Mini **DV** Digital
Video
Cassette

SCD5000

- AF** Auto Focus
CCD Charge Coupled Device
LCD Liquid Crystal Display

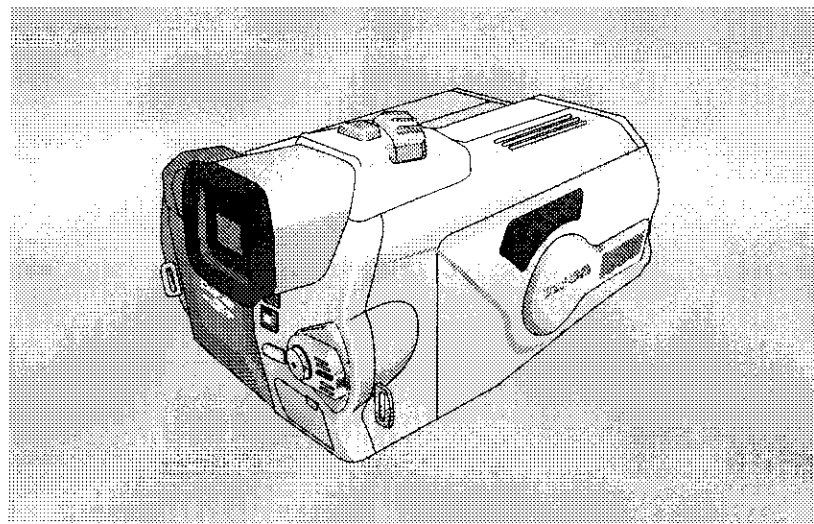



Owner's Instruction Manual

Before operating the unit, please read this instruction manual thoroughly, and retain it for future reference.

US PATENT 4415844

Notices and Safety Instructions

Safety Instructions

	CAUTION RISK OF ELECTRIC SHOCK DO NOT OPEN	
CAUTION: TO REDUCE THE RISK OF ELECTRIC SHOCK, DO NOT REMOVE COVER(OR BACK). NO USER SERVICEABLE PARTS INSIDE, REFER SERVICING TO QUALIFIED SERVICE PERSONNEL.		



This symbol is intended to alert the user to the presence of uninsulated dangerous voltage within the product's enclosure that may be of sufficient magnitude to constitute a risk of fire or electric shock.



This symbol is intended to alert the user to the presence of important operating and maintenance instructions in the literature accompanying this product.

To prevent electric shock, match wide blade of plug to wide slot and fully insert.

1. READ INSTRUCTIONS:

All the safety and operating instructions should be read before the CAMCORDER is operated.

2. RETAIN INSTRUCTIONS:

The safety and operating instructions should be retained for future reference.

3. HEED WARNINGS:

All warnings on the CAMCORDER and in the operating instructions should be adhered to.

4. FOLLOW INSTRUCTIONS:

All operating and maintenance instructions should be followed.

5. CLEANING:

Unplug this CAMCORDER from the wall outlet before cleaning. Do not use liquid or aerosol cleaners. Use a dry cloth used for dusting cabinets.

6. ATTACHMENTS:

Do not use attachments not recommended by the CAMCORDER product manufacturer as they may be hazardous.

7. WATER AND MOISTURE:

Do not use this CAMCORDER near water; for example, near a bathtub, wash bowl, kitchen sink, laundry tub, in a wet basement, near a swimming pool or lake.

8. ACCESSORIES:

Do not place this CAMCORDER on an unstable cart, stand, tripod, bracket or table. The CAMCORDER may fall, causing serious injury to a child or adult, and serious damage to the unit. Use only with a cart, stand, tripod, bracket, or table recommended by the manufacturer or sold with the CAMCORDER. Any mounting of the unit should follow the manufacturer's instructions and should use a mounting accessory recommended by the manufacturer.

A. An appliance and cart combination should be moved with care. Quick stops, excessive force and uneven surfaces may cause the appliance and cart combination to overturn.

PORTABLE CART WARNING
(Symbol provided by RETAC)



Notices and Safety Instructions

9. VENTILATION:

Slots and openings in the cabinet are provided for ventilation to ensure reliable operation of the CAMCORDER and to protect it from overheating. These openings must not be blocked or covered. Never place your CAMCORDER on a bed, sofa, rug, or other similar surface: on or near a radiator or heat register. This CAMCORDER should not be placed in a built-in installation such as a bookcase or rack unless proper ventilation is provided or the manufacturer's instructions have been adhered to.

10. POWER SOURCES:

The CAMCORDER should be operated only from the type of power source indicated on the label.

If you are not sure of the type of power supply at your home, consult your appliance dealer or local power company.

A CAMCORDER is intended to be operated from battery power, or other sources, refer to the operating instructions.

11. GROUNDING OR POLARIZATION:

This CAMCORDER may be equipped with either a polarized 2-wire AC line plug (a plug having one blade wider than the other) or a 3-wire grounding type plug, a plug having a third (grounding) pin.

If you are unable to insert the plug fully into the outlet, try reversing the plug. If the plug still fails to fit, contact your electrician to replace your outlet. Do not defeat the safety purpose of the polarized plug.

12. POWER-CORD PROTECTION:

Power-supply cords should be routed so that they are not likely to be walked on or pinched by items placed upon or against them, paying particular attention to cords or plugs, convenient receptacles, and the point where they exit from the unit.

13. OUTDOOR ANTENNA GROUNDING:

If an outside antenna or cable system is connected to the CAMCORDER, be sure the antenna or cable system is grounded to provide some protection against voltage surges and built-up static charges. Section 810 of the National Electrical Code, ANSI/NFPA No. 70-1984, provides information with respect to proper grounding of the mast and supporting structure, grounding of the lead-in wire and supporting structure, grounding of the mast and supporting structure, grounding of the lead-in wire to an antenna discharge unit, size of grounding to conductors, location of antenna-discharge unit, connection to grounding electrodes and requirements for the grounding electrode.

See figure below.

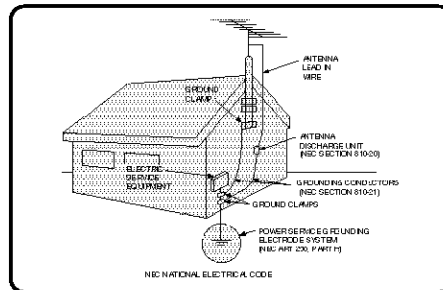

Notices and Safety Instructions

14. LIGHTNING:

For added protection of this CAMCORDER during a lightning storm or when it is left unattended and unused for long periods of time, unplug it from the wall outlet and disconnect the antenna or cable system.

This will prevent damage to the CAMCORDER due to lightning and power-line surges.

15. POWER LINES:

An outside antenna system should not be located in the vicinity of overhead power lines or other electric light or power circuits where it can fall into such power lines or circuits. When installing an outside antenna system, extreme care should be taken to keep from touching such power lines or circuits as contact with them might be fatal.

16. OVERLOADING:

Do not overload wall outlets and extension cords as this can result in a risk of fire or electric shock.

17. OBJECTS AND LIQUIDS:

Never push objects of any kind into this CAMCORDER through openings as they may touch dangerous voltage points or short out a part that could result in a fire or electric shock.

Never spill liquids of any kind onto the CAMCORDER. Should spillage occur, unplug unit and have it checked by a technician before use.

18. SERVICING:

Do not attempt to service this CAMCORDER yourself. Opening or removing covers may expose you to dangerous voltage or other hazards.

Refer all servicing to qualified service personnel.

19. DAMAGE REQUIRING SERVICE:

Unplug this CAMCORDER from the wall outlet and refer servicing to qualified service personnel under the following conditions:

- a. When the power-supply cord or plug is damaged.
- b. If any liquid has been spilled onto, or objects have fallen into the CAMCORDER.
- c. If the CAMCORDER has been exposed to rain or water.
- d. If the CAMCORDER does not operate normally by following the operating instructions, adjust only those controls that are covered by the operating instructions. Improper adjustment of other controls may result in damage and will often require extensive work by a qualified technician to restore the CAMCORDER to its normal operation.
- e. If the CAMCORDER has been dropped or the cabinet has been damaged.
- f. When the CAMCORDER exhibits a distinct change in performance, this indicates a need for service.

20. REPLACEMENT PARTS:

When replacement parts are required, be sure the service technician has used replacement parts specified by the manufacturer and having the same characteristics as the original part.

Unauthorized substitutions may result in fire, electric shock or other hazards.

21. SAFETY CHECK:

Upon completion of any service or repairs to this CAMCORDER, ask the service technician to perform safety checks to determine that the CAMCORDER is in safe operating order.

Notices and Safety Instructions

22. To prevent damage which may result in fire or shock hazard, do not expose this appliance to rain or moisture.
23. If this power supply is used at 240V ac, a suitable plug adapter should be use.

NOTE TO CATV SYSTEM INSTALLER:

This reminder is provided to call the CATV system installer's attention to Article 820-40 of the NEC that provides guidelines for proper grounding and, in particular, specifies that the cable ground shall be connected to the grounding system of the building as close to the point of cable entry as practical.

USER INSTALLER CAUTION:

Your authority to operate this FCC certified equipment could be voided if you make changes or modifications not expressly approved by this party responsible for compliance to part 15 FCC rules.

NOTE: This equipment has been tested and found to comply with the limits for a Class B digital device, pursuant to part 15 of the FCC Rules. These limits are designed to provide reasonable protection against harmful interference in a residential installation. This equipment generates, uses and can radiate radio frequency energy and, if not installed and used in accordance with the instructions, may cause harmful interference to radio communications. However, there is no guarantee that interference will not occur in a particular installation. If this equipment does cause harmful interference to radio or television reception, which can be determined by turning the equipment off and on, the user is encouraged to try to correct the interference by one or more of the following measures:

- Reorient or relocate the receiving antenna.
- Increase the separation between the equipment and receiver.
- Connect the equipment into an outlet on a circuit different from that to which the receiver is connected.
- Consult the dealer or an experienced radio/TV technician for help and for additional suggestions.

The user may find the following booklet prepared by the Federal Communications Commission helpful : "How to identify and Resolve Radio-TV Interference Problems."

This Booklet is available from the U.S. Government Printing Office, Washington, D.C. 20402, Stock No. 004-000-00345-4.

FCC Warning

The user is cautioned that changes or modifications not expressly approved by the manufacturer could void the user's authority to operate the equipment.

Contents

Start	8
Precautions on Camcorder Care	8
Quick Start	9
Notes and Safety Instructions	10
Getting to Know Your Device	14
Features	14
Accessories Supplied with the Camcorder	15
Basic Accessories	15
Front & Left View	16
Left side View	17
Right & Top View	18
Rear & Bottom View	19
Remote Control	20
OSD (On Screen Display in CAMERA and PLAYER Modes)	21
OSD (On Screen Display in CAMERA / M.PLAY Modes)	22
Turning the OSD on/off (On Screen Display)	23
Preparation	24
How to use the Remote Control	24
Battery Installation for the Remote Control	24
Self Record using the Remote Control	24
Adjusting the Hand Strap	25
Hand strap	25
Shoulder strap.....	25
Connecting a Power Source	26
To use the AC Power adapter and DC Cable	26
Using the Lithium Ion Battery Pack	27
Charging the Lithium Ion Battery Pack	27
Table of Continuous Recording Time Based on Model and Battery Type	28
Battery Level Display	29

Contents

Setting to CAMCORDER / CAMERA modes	30
Setting the Power Switch	31
Adjusting the LCD	32
Using the VIEWFINDER	33
Adjusting the Focus	33
Adjusting the LCD during PLAY	34
Controlling Sound from the Speaker	34
Functions	35
Using MENU	35
Setting menu items	37
Setting the Camcorder to REC, TAPE PLAY, MEMORY PLAY modes	39
Availability of Functions in CAMCORDER Mode.	40
CLOCK SET	41
WL.REMOTE	42
DEMONSTRATION	43
DATE/TIME	44
TV DISPLAY	45
EASY Mode (for Beginners)	46
MF/AF (Manual Focus/Auto Focus)	47
Auto Focusing	47
Manual Focusing	47
Zooming In and Out with DIGITAL ZOOM	48
Zooming In and Out	48
Using the CAMCORDER - Basic Recording	49
Inserting and Ejecting a Cassette	49
To select the CAMCORDER mode	49
Making Your First Recording	51
Record Search (REC SEARCH)	52
Hints for Stable Image Recording	53
Recording with the LCD Monitor	53
Recording with the Viewfinder	53
Playing Back a Tape You Have Recorded on the LCD	54

Contents

Using the CAMCORDER - Advanced Recording	55
PROGRAM AE	55
Setting PROGRAM AE	56
WHT. BALANCE (WHITE BALANCE) - CAMCORDER Mode	57
Digital Zoom in CAMCORDER Mode	58
EiS (Electronic Image Stabilizer)	59
DSE(Digital Special Effects) SELECT in CAMCORDER Mode	60
Selecting a Digital effect in CAMCORDER Mode	61
REC MODE	62
AUDIO MODE	63
WIND CUT	64
Using Quick Menu(Navigation Menu)	65
Setting the Quick Menu	66
SHUTTER SPEED & EXPOSURE	67
SLOW SHUTTER (Low Shutter Speed)	68
BLC (Back Light Compensation)	69
Fade In and Out	70
To Start Recording	70
To Stop Recording (use FADE IN / FADE OUT)	70
Audio Dubbing	71
Dubbing Sound	71
Dubbed Audio Playback	72
PHOTO Image Recording	73
Searching for a PHOTO Picture	73
NITE PIX (0 Lux Recording)	74
POWER NITE PIX	75
Various Recording Techniques	76
Playback	77
Tape Playback	77
Playback on the LCD	77
Playback on a TV Monitor	77
Connecting to a TV which has Audio Video Input Jacks	77

Contents

Connecting to a TV which has No Audio and Video Input Jacks	78
Playback	78
Various Functions while in PLAYER Mode	79
Playback Pause	79
Picture Search (Forward/Reverse)	79
Slow Playback (Forward)	79
ZERO MEMORY	80
<i>IEEE 1394 Data Transfer</i>	81
Transferring using IEEE1394 (i.LINK)-DV Standard Data Connections	81
Connecting to a DV Device	81
Connecting to a PC	81
System Requirements	82
Recording with a DV Connection Cable	82
<i>Using the CAMERA</i>	83
MEMORY STICK	83
Memory Stick Functions	83
Inserting and Ejecting the Memory Stick	84
Inserting the Memory Stick	84
Ejecting the Memory Stick	84
Structure of the Folders and Files on the Memory Stick	85
MEMORY FILE NUMBER	86
<i>Basic Picture-Taking</i>	87
Taking Your First Picture	87
Viewing Still Images	88
To View a Single image	88
To View a Slide Show	89
Quick Review	90
Adjusting the Focus	91

<i>Advanced Techniques</i>	92
FOCUS LOCK	92
Digital Zoom in CAMERA Mode	93
MACRO Mode	94
CONT. SHOT (Continuous Shot)	95
Using the FLASH	96
FLASH SELECT	97
WHT. BALANCE (WHITE BALANCE) - CAMERA Mode	98
DSE(Digital Special Effects) SELECT in CAMERA Mode	99
Selecting a Digital effect in CAMERA Mode	100
SPOT-AE	101
NIGHT SCENE	102
Selecting the Image Quality	103
Select the Image Quality	103
Number of images on the Memory Stick	103
Selecting the image Size	104
Select the image Size	104
Memory Stick and Image Resolutions	105
MPEG REC	106
MPEG PB	107
MPEG SIZE	108
Copying Still Images from a Cassette to the Memory Stick	109
Marking Images for Printing	110
Protection from Accidental Erasure	111
Deleting Still images	112
Formatting the Memory Stick	114
Attention	114
Recording an Image from a Cassette as a Still Image.	115

USB Interface	116
Transferring a Digital Image through a USB Connection	116
System Requirements	116
Installing the DVC Media 5.0 Program	117
Connecting to a PC	118
Maintenance	119
After Finishing a Recording	119
Cleaning and Maintaining the Camcorder	120
Cleaning the Video Heads	120
Using Your Camcorder Abroad	121
Power Sources	121
Color System	121
Troubleshooting	122
Troubleshooting	122
Self Diagnosis Display	122
Moisture Condensation	122
Self Diagnosis Display in M.REC, M.PLAY Mode	123
Specifications	125
INDEX	126
Warranty	128

Start

Precautions on Camcorder Care

- ❖ Please note the following precautions for use:
- ❖ Please keep your device in a safe place. This device contains a lens that can be damaged by shock. Keep away from the reach of the children.

- Do not place your device in a wet place. Moisture and water may cause the device to malfunction.
- Do not aim the device at the sun while looking through the viewfinder; this may cause permanent damage to your eyes.
- To avoid electric shock, do not touch your device or power cable with wet hands.
- Do not use the flash close to another's eyes. The flash emits a strong light that may cause damage similar to direct sunlight on one's eyesight.
- If the device is not working properly, please consult your nearest dealer or authorized Samsung service facility. Disassembling the device yourself may cause irrecoverable damage which will be difficult to repair.
- Clean the body with a dry, soft cloth. Use a soft cloth moistened with a mild detergent solution for removing stains. Do not use any type of solvent, especially benzenes, as they may seriously damage the finish.
- Keep your device away from rain and saltwater. After using, clean the device. Saltwater may cause the parts to corrode.
- For better quality, please use CAMERA mode when taking still images. (CAMERA mode image quality is better than CAMCORDER mode.)

Start

Quick Start

- ✦ This device provides a variety of functions because it is a Camcorder and Digital Still Camera in one system. Please read this manual thoroughly.
- ✦ Before using the device, install the accessories in the following order:

1. Install the battery pack.
2. Insert the Memory Stick into the slot.
3. Charge the battery pack by connecting the power cable to the camcorder.
4. Set your device to CAMCORDER mode or CAMERA mode by flipping the lens body block.
5. Set the Power Switch to proposed position.
6. When finished, set the Power Switch to OFF.

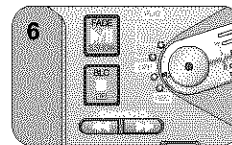
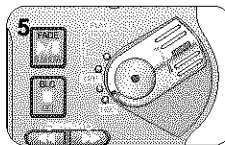
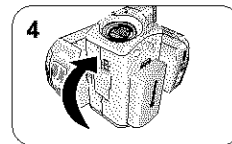
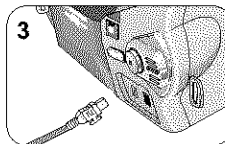
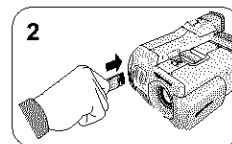
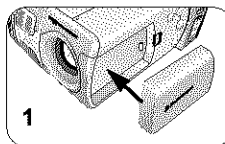

Notes and Safety Instructions

Notes Regarding the Rotation of the LCD Screen

Please rotate the LCD screen carefully as illustrated.

Over rotation may cause damage to the inside of the hinge that connects the LCD screen to the Camcorder.

1. LCD screen closed.
2. Standard recording using the LCD screen.
3. Recording when looking at the LCD screen from the left.
4. Recording when looking at the LCD screen from the front.
5. Recording with the LCD screen closed.

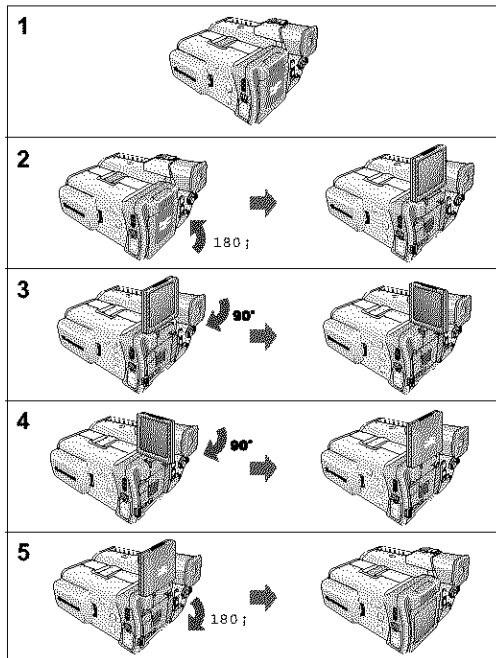

Notes and Safety Instructions

Notices Regarding COPYRIGHT

Television programs, video tapes, DVD titles, films, and other program materials may be copyrighted. Unauthorized copying of copyrighted material may be against the law.

Notes Regarding Moisture Condensation

1. A sudden rise in atmospheric temperature may cause moisture condensation to form inside the camcorder.

For Example:

- When you take the camcorder from a cold place to a warm place (e.g. from outside to inside during winter.)
 - When you take the camcorder from a cool place to a hot place (e.g. from inside to outside during the summer.)
2. When the  (DEW) protection feature is activated, leave the camcorder in a dry, warm room with the cassette compartment opened and the battery removed, for at least two hours.

Notes Regarding the CAMCORDER

1. Do not leave the camcorder exposed to high temperatures (above 60°C or 140°F).
For example, in a parked car in the sun or exposed to direct sunlight.
2. Do not let the camcorder get wet.
Keep the camcorder away from rain, saltwater, and any other form of moisture. If the camcorder gets wet, it may be damaged.
A malfunction due to exposure to liquids cannot always be repaired.

Notes and Safety Instructions

Notes Regarding the Battery Pack

- Make sure that the battery pack is fully charged before starting to record.
- To preserve battery power, keep your camcorder turned off when you are not operating it.
- If your device is in CAMCORDER mode with a tape installed, and it is left in STBY mode without being operated for more than 5 minutes it will automatically turn itself off to protect against unnecessary battery discharge.
- Make sure that the battery pack fits firmly into place.
Dropping the battery pack may damage it.
- A brand new battery pack will not be charged.
Before using the battery pack, you need to charge it completely.
- It is a good idea to use the viewfinder rather than the LCD when recording for long periods, because the LCD uses up more battery power.

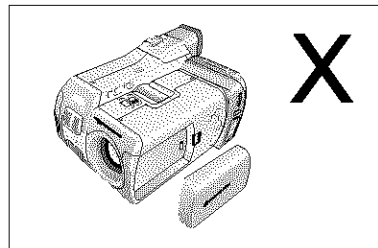

- * When the battery reaches the end of its life, please contact your local dealer.
The batteries need to be dealt with as chemical waste.
- * Be careful not to drop the battery when you release it

Notes Regarding Video Head Cleaning

- To ensure normal recording and a clear picture, clean the video heads regularly. If the picture is distorted, or only a blue screen is displayed, the video heads may be dirty. If this happens, clean the video heads with a dry type cleaning cassette.
- Do not use a wet-type cleaning cassette. It may damage the video heads.

Notes and Safety Instructions

Note Regarding the LENS

- Do not film with the camera lens pointing directly at the sun.
Direct sunlight can damage the CCD (Charge Coupled Device).
- Over-rotating of the LENS body block may damage it.

Notes Regarding Electronic Viewfinder

1. Do not position the camcorder such that the viewfinder is pointing towards the sun.
Direct sunlight can damage the inside of the viewfinder. Be careful when placing the camcorder under sunlight or near a window exposed to sunlight.
2. Do not pick up the camcorder by the viewfinder.

Notes Regarding 'Record' or 'Playback' Using the LCD

1. The LCD display has been manufactured using high-precision technology. However, there may be tiny dots (red, blue or green in color) that appear on the LCD display.
These dots are normal and do not affect the recorded picture in any way.
2. When you use the LCD display under direct sunlight or outdoors, it may be difficult to see the picture clearly.
If this occurs, we recommend using the viewfinder.
3. Direct sunlight can damage the LCD monitor.



Notes Regarding the Hand Strap

- To ensure a steady picture during filming, check that the hand strap is properly adjusted.
- Do not force your hand into the hand strap as you could damage it.

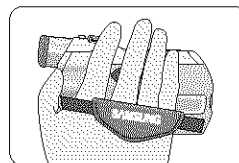

Getting to Know Your Device

Features

- **Digital data transfer function with IEEE1394**

By incorporating the IEEE 1394 (i.LINK™ : i.LINK is a serial data transfer protocol and interconnectivity system, used to transmit DV data) high speed data transport port, both moving and still images can be transferred to a PC, making it possible to produce or edit various images.

- **Unique Style & Free Style Shooting**

An integrated digital imaging device that easily converts between a CAMCORDER and a CAMERA by using a revolving Lens Body Block.

- **High Resolution Image Quality (Digital Still Camera)**

Employing a 4.13 Mega Pixels CCD, a maximum resolution of 2272 X 1704 is possible.

- **Digital Zoom**

Allows you to magnify an image up to 800X (CAMCORDER mode) or 6X (CAMERA mode) its original size.

- **Color TFT LCD**

A high-resolution color TFT LCD gives you clean, sharp images as well as the ability to review your recordings immediately.

- **Electronic Image Stabilizer (EIS)**

The EIS compensates for any shaking that occurs when the camera is handheld, reducing unstable images particularly at high magnification.

- **Various Digital Effects**

The DSE (Digital Special Effects) function allows you to give your films a special look by adding various special effects.

- **Back Light Compensation (BLC)**

The BLC function compensates for a bright background behind the subject you're recording.

- **Program AE**

The Program AE enables you to alter the shutter speed and aperture to suit the type of scene/action to be filmed.

- **NITE PIX / NIGHT SCENE**

The NITE PIX or NIGHT SCENE function enables you to record a subject in a dark place.

- **USB Interface for Digital Image Data Transfer**

You can transfer still images to a PC using the USB interface without an add-on card.











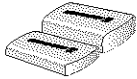

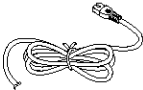
Getting to Know Your Device

Accessories Supplied with the Camcorder

Make sure that the following basic accessories are supplied with your digital video camera.

Basic Accessories

1. Lithium Ion Battery Pack
2. AC Power Adapter
3. AC Cord
4. AUDIO/VIDEO Cable
5. Instruction Manual
6. Lithium Battery for Remote Control.
(TYPE: CR2025)
7. Shoulder Strap
8. USB Cable
9. Software CD
10. Remote Control
11. Memory Stick
12. Tripod Adaptor

1. Lithium Ion Battery pack (AD43-00112A, AD43-00113A) 	2. AC Power Adapter (AD44-00065A) 	3. AC cord (AD39-00076A) 
4. AUDIO/VIDEO cable (AD39-00099A) 	5. Instruction Book (AD68-000655B) 	6. Lithium battery (AD43-10130H) 
7. Shoulder strap (AD72-00050A) 	8. USB cable (AD39-00073A) 	9. Software CD (AD46-00063A) 
10. Remote Control (AD59-00100A) 	11. Memory Stick (1109-001222) 	12. Tripod Adapter (AD97-06770A) 

Getting to Know Your Device

Front & Left View

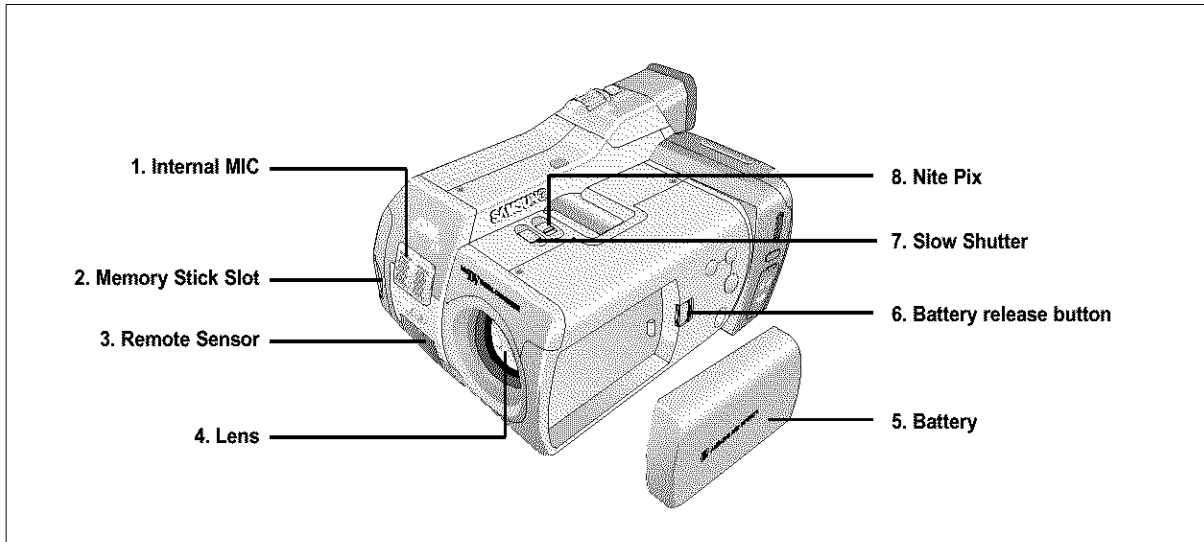

1. Internal MIC

2. Memory Stick Slot

3. Remote Control Sensor

4. Lens

5. Battery

6. Battery release button

7. Slow Shutter

8. Nite Pix

Getting to Know Your Device

Left Side View

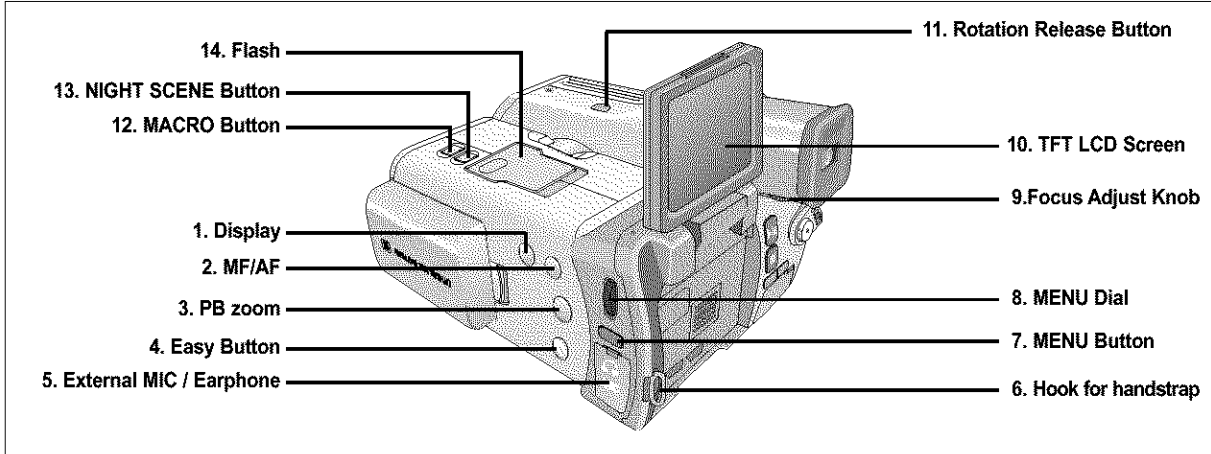

- 1. Display
- 2. MF/AF
- 3. PB Zoom
- 4. Easy Button
- 5. External MIC / Earphone
- 6. Hook for handstrap
- 7. MENU Button

- 8. MENU Dial
- 9. Focus Adjust knob
- 10. TFT LCD Screen
- 11. Rotation Release Button
- 12. MACRO Button
- 13. NIGHT SCENE Button
- 14. Flash

Getting to Know Your Device

Right & Top View

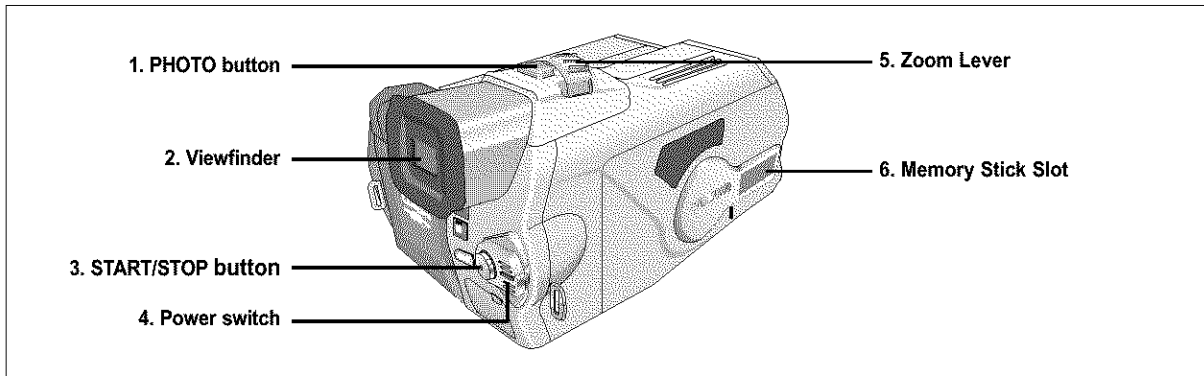

1. Photo Button

2. Viewfinder

3. Start/Stop Button

4. Power switch

5. Zoom Lever

6. Memory Stick Slot

Getting to Know Your Device

Rear & Bottom View

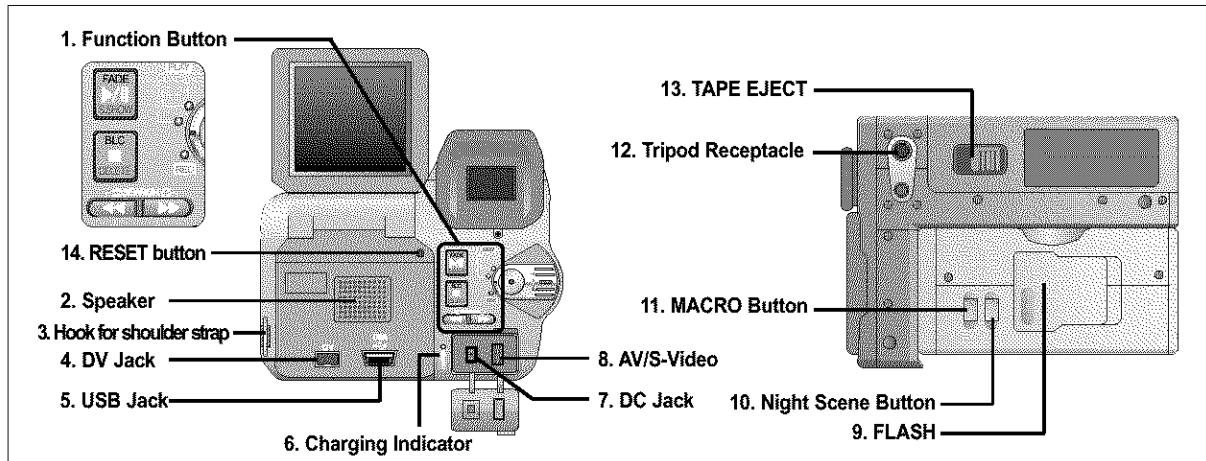

1. Function Button

TAPE PLAY	REC	MEMORY PLAY
-	EASY	MULTI
⏮ : (REW)	REC SEARCH -	REV
⏭ : (FF)	REC SEARCH +	FWD
▶/ : (PLAY/STILL)	FADE	SLIDE SHOW
■ : (STOP)	BLC	SPOT AE

2. Speaker

3. Hook for the shoulder strap

4. DV Jack

5. USB Jack

6. Charging Indicator

7. DC Jack

8. AV/S-Video

9. FLASH

10. Night Scene Button

11. MACRO Button

12. Tripod Receptacle

13. TAPE EJECT

14. RESET button

Getting to Know Your Device

Remote Control

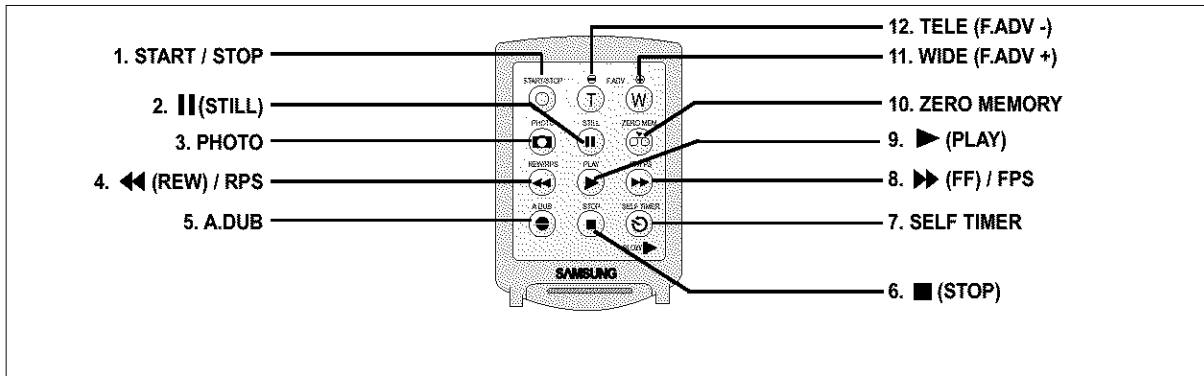

1. START / STOP

2. ||(STILL)

3. PHOTO

4. ◀◀ (REW) / RPS

5. A.DUB

6. ■ (STOP)

7. SELF TIMER

8. ▶▶ (FF) / FPS

9. ▶ (PLAY)

10. ZERO MEMORY

11. WIDE (F.ADV +)

12. TELE (F.ADV -)

Getting to Know Your Device

OSD (On Screen Display in CAMERA and PLAYER Modes)

1. Battery Level (See page 29)
2. Easy Mode (See pages 46)
3. Slow Shutter (See pages 68)
4. DSE (Digital Special Effects) Mode (See page 60)
5. BLC (Back Light Compensation) (See page 69)
6. Program AE (See page 55)
7. White Balance Mode (See page 57)
8. Manual Focus (See page 47)
9. POWER NITE PIX (See page 75)
10. Zoom Position (See page 48)
11. Shutter Speed and EXPOSURE (See page 67)
12. NITE PIX (See page 74)
13. DATE / TIME (See page 44)
14. USB (See page 116)
15. WL.REMOTE (See page 42)
16. WIND CUT (See page 64)
17. Audio recording mode (See page 63)
18. Message Line
19. Zero Memory Indicator (See page 80)
20. Remaining Tape (measured in minutes)
21. Tape Counter
22. Operating Mode
23. Record Speed Mode (See page 62)
24. PHOTO Mode (See page 73)
25. Self Recording and Waiting Timer (See page 24)
26. EIS (See page 59)
27. Audio Playback Channel (See page 72)
28. Volume Control (See page 34)
29. DV IN (DV data transfer mode) (See page 82)
30. DEW (See page 11)

OSD in CAMCORDER mode

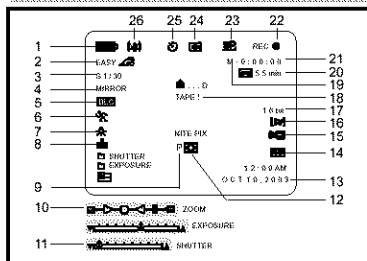

OSD in TAPE PLAY mode

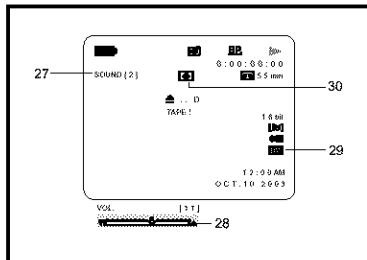

Getting to Know Your Device

OSD (On Screen Display in CAMERA/M.PLAY Modes)

1. Battery Level (See page 27)
2. DSE (Digital Special Effects) Mode (See page 99)
3. SPOT AE Mode (See page 101)
4. Focus Area
5. White Balance Mode (See page 98)
6. Manual Focus (See page 57)
7. NIGHT SCENE (See page 102)
8. FLASH Mode (See page 97)
9. MACRO Mode (See page 95)
10. Image Size (See page 104)
11. Image Counter
- Current still image/Total number of recordable still images.
12. CARD (MEMORY STICK) Indicator
13. Image Recording and Loading Indicator
14. Image Quality (See page 103)
15. Focus (See page 91)
16. SLIDE SHOW (See page 89)
17. ERASE PROTECTION indicator (See page 111)
18. Print Mark (See page 110)
19. Message Line
20. Folder number-file number (See page 85)
21. Continuous Shot (See page 95)

OSD in CAMERA mode

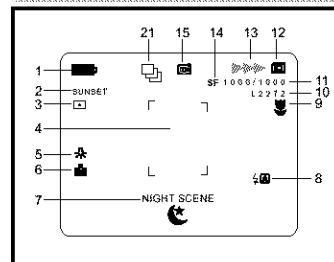

OSD in M.PLAY mode

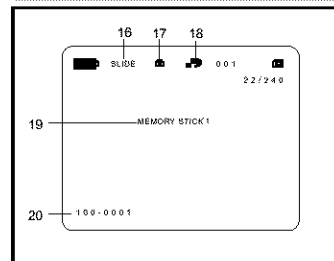

Getting to Know Your Device

Turning the OSD ON/OFF (On Screen Display)

• Turning OSD ON/OFF

Press the DISPLAY button.

- Each press of the button toggles the OSD function ON and OFF.

- When you turn the OSD OFF,

in CAMCORDER / CAMERA mode: The STBY, REC, EASY.Q modes are always displayed on the OSD, even when the OSD is turned OFF. The key input is displayed for 3 seconds then turned off.

in PLAYER mode: When you press any Function button, the function is displayed on the OSD for 3 seconds before it disappears.

• Turning the DATE/TIME ON/OFF

- The DATE/TIME is not affected when the OSD function is switched ON or OFF.

- To turn the DATE/TIME ON or OFF, access the menu and change the DATE/TIME mode. (See page 50)

- You may also use the Quick Menu to turn the DATE/TIME ON or OFF. (See page 65)
(only in CAMCORDER / CAMERA mode)

Preparation

How to use the Remote Control

Battery Installation for the Remote Control

- ✦ You need to insert or replace the lithium battery when :
 - You purchase the camcorder.
 - The remote control doesn't work.
- ✦ Make sure that you insert the lithium cell correctly, following the + and - markings.
- ✦ Be careful not to reverse the polarity of the battery.

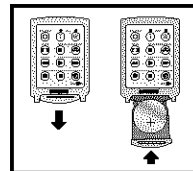

Self Timer Recording and Photography Using the Remote Control

When you use the Self Timer function on the remote control, recording begins automatically in 10 seconds.

1. Set the device to CAMCORDER or CAMERA mode.
2. Press the SELF-TIMER button until the appropriate indicator is displayed in the LCD or viewfinder.
3. Press the START/STOP button or the PHOTO Button to start the timer.
 - After 10 seconds, recording or photography begins.
 - Press START/STOP again when you want to stop recording.

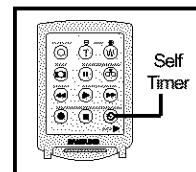

Preparation

Adjusting the Hand Strap

It is very important to ensure that the Hand Strap has been correctly adjusted before you begin recording.

The hand strap enables you to :

- Hold the camcorder in a stable, comfortable position.
- Press the Zoom START/STOP, and PHOTO button without having to change the position of your hand.

Hand Strap

- a. Pull the Hand Strap cover open and release the Hand Strap.
- b. Adjust its length and stick it back into the Hand Strap cover.
- c. Close the Hand Strap cover.

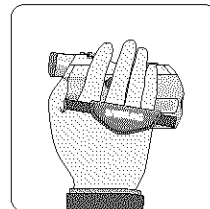
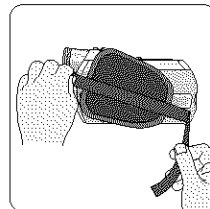

Shoulder Strap

The Shoulder Strap enables you to carry your camcorder around in complete safety.

1. Insert the end of strap into the Shoulder Strap hook on the camcorder.
Insert the other end of strap into the ring inside the hand strap.
2. Thread each end into the buckle, adjust the length of the strap and then pull it tight in the buckle.

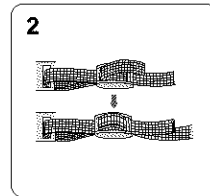
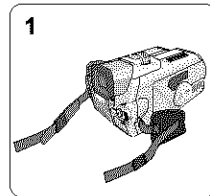

Preparation

Connecting a Power Source

There are two types of power sources that can be connected to your camcorder.

- The AC Power Adapter with the AC cord : used for indoor recording.
- The Battery Pack : used for outdoor recording.

To Use the AC Power Adapter and DC Cable

1. Connect the AC Power adapter to the AC cord.
2. Connect the AC cord to a wall socket.

Note

The plug and wall socket type may differ according to your country of residence.

3. Connect the DC cable to the DC jack socket on the camcorder.
4. Set the camcorder to different modes by holding down the tab on the power switch and turning it to REC, TAPE PLAY, MEMORY PLAY modes.

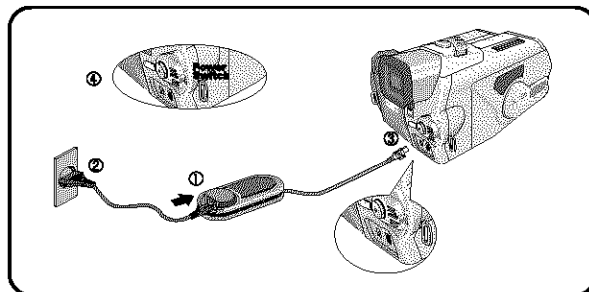

Preparation

Using the Lithium Ion Battery Pack

- ❖ The amount of continuous recording time available depends on :
 - The type and capacity of the battery pack you are using.
 - How often the Zoom function is used.
 It is recommended that you have several batteries available.

Charging the Lithium Ion Battery Pack

1. Attach the battery pack to the device.
2. Connect the AC Power adapter to the AC cord and connect the AC cord to a wall socket.
3. Connect the DC cable to the DC jack socket on the camcorder.
4. Turn the Camera power switch to OFF, and the charging indicator will start to flash, showing that the battery is charging.

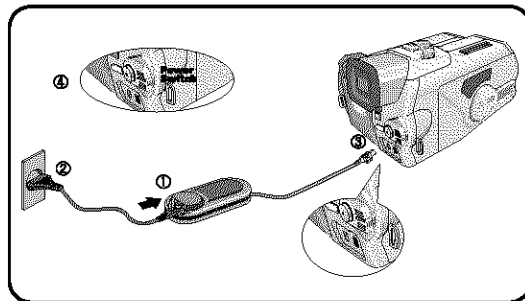

Blinking time	Charging rate
Once per second	Less than 50%
Twice per second	50% ~ 75%
Three times per second	75% ~ 90%
Blinking stops and stays on	90 ~ 100%
On for a second and off for a second	Error - Reset the battery pack and the DC cable

5. When the battery is fully charged, disconnect the battery pack and the AC Power adapter from the camcorder.
 - Even with the power switched off, the battery pack will still discharge if it is left connected to the camcorder.

Notes

- The battery pack may be charged a little at the time of purchase.
- To prevent reduction in the life and capacity of the battery pack, always remove it from the camcorder after it is fully charged.

Preparation

Using the Lithium Ion Battery Pack

Table of Continuous Recording Time Based on Model and Battery Type.

- ❖ If you close the LCD screen, it switches off and the viewfinder switches on automatically.
- ❖ The continuous recording times given in the table above are approximations.
Actual recording time depends on usage.

Time Battery	Charging time	Continuous recording time	
		LCD ON	EVF ON
SB-L70G	Approx. 1hr 20min	Approx. 58min	Approx. 1hr 2min
SB-L110G	Approx. 1hr 40min	Approx. 1hr 30min	Approx. 1hr 40min

Notes

- The battery pack should be recharged in an environment between 32°F (0°C) and 104°F (40°C).
- The battery pack should never be charged in a room temperature that is below 32°F (0°C).
- The life and capacity of the battery pack will be reduced if it is used in temperatures below 32°F (0°C) or left in temperatures above 104°F (40°C) for a long period, even when it is fully recharged.
- Do not put the battery pack near any heat source (fire or flames, for example).
- Do not disassemble, apply pressure to, or heat the Battery Pack.
- Do not allow the + and - terminals of the battery pack to be short-circuited.
It may cause leakage, heat generation, induce fire or overheating.

Preparation

Battery Level Display

- The battery level display indicates the amount of power remaining in the battery pack.
 - a. Fully Charged
 - b. 20~40% Used
 - c. 40~80% Used
 - d. 80~95% Used
 - e. Completely Used (flickers)
(The device will turn off soon, change the battery as soon as possible)
- ❖ Please refer to the table on page 28 for approximate continuous recording times.
- ❖ The recording time is affected by temperature and environmental conditions.
The recording time becomes very short in a cold environment. The continuous recording times in the operating instructions are measured using a fully charged battery pack at 77°F(25°C). As the temperature and environmental conditions may differ from this when you actually use the camcorder, the remaining battery time may not be the same as the approximate continuous recording times given in these instructions.

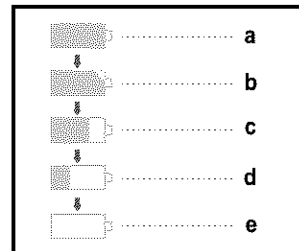

Preparation

Setting to CAMCORDER / CAMERA modes

- ❖ This device switches between the DVC (Digital Video Camcorder) mode and the DSC (Digital Still Camera) mode by revolving the Lens Body Block.
- ❖ Switching between CAMCORDER/CAMERA Modes
 - To set your device to CAMERA Mode from CAMCORDER Mode: Rotate the Lens Body Block 180° counterclockwise while pressing the Rotation Release Button (Left View).
 - * Follow the (∨) mark printed on the LENS body block when rotating it.
 - To set your device to CAMCORDER Mode from CAMERA Mode: Rotate the Lens Body Block 180° clockwise while pressing the Rotation Release Button (Left View).
 - * To rotate the LENS body block safely, please wait for the lens to shut after rotating 90°. After lens is shut, rotate the LENS body block further.
 - * Follow the (∨) mark printed on the LENS body block when rotating it.

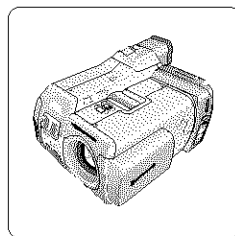
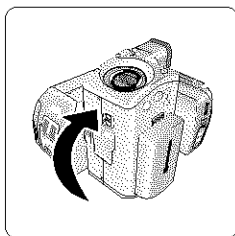
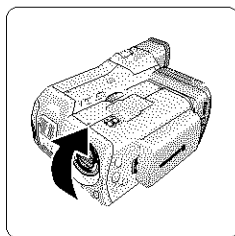

Warning

- Do not rotate the lens body block by force, or without pressing the Release button. It may break the device.
- Rotating the Lens Body Block while power is being supplied may stop recording and cause problems with the device.

Preparation

Setting the Power Switch

- ❖ Use the Power Switch to select the working modes of the device.
 - REC mode: Record onto a tape or store images on the Memory Stick.

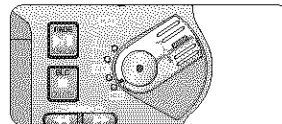

- OFF: Turn the device off. To recharge the battery, connect the power cable while the Power Switch is set to OFF.

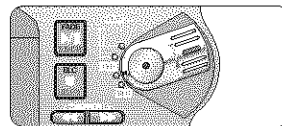

- TAPE PLAY (PLAYER) mode: Play and edit the recorded tape.

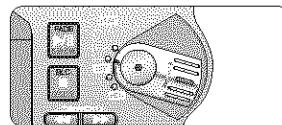

- MEMORY PLAY (M.PLAY) mode: View and edit images and motion clips stored on the Memory Stick.

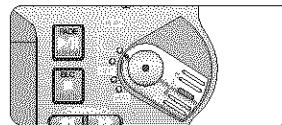

Preparation

Adjusting the LCD

- ❖ Your camcorder is equipped with a 2 inch color Liquid Crystal Display(LCD) screen, which enables you to view what you are recording and play back directly.
 - ❖ Depending on the conditions under which you are using the camcorder (indoors or outdoors), you can adjust ;
 - BRIGHT ADJUST
 - COLOR ADJUST
1. Set the POWER switch to REC mode.
 - In PLAYER mode, you can only setup the LCD while the tape is playing.
 2. Open the LCD screen. The LCD switches on.
 3. Press the MENU button.
 4. Turn the MENU DIAL so that VIEWER is highlighted and then press the MENU DIAL.
 5. Turn the MENU DIAL so that LCD ADJUST is highlighted.
 6. Press the ENTER button to enter the sub-menu.
 7. Turn the MENU DIAL so that it highlights the menu item you want to adjust (BRIGHT ADJUST, COLOR ADJUST).

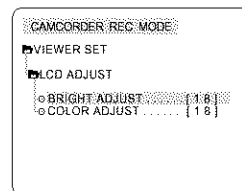
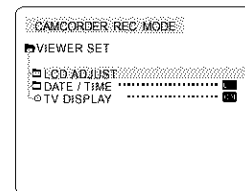
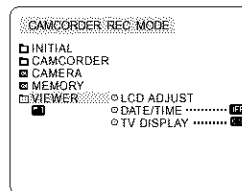
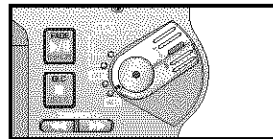

Preparation

8. Press the MENU DIAL.
 - Use the MENU DIAL to adjust the value of BRIGHT ADJUST and COLOR ADJUST.
 - You can set the values for BRIGHT ADJUST between 0 ~ 35 and COLOR ADJUST between 0 ~ 35.
9. Press the MENU button to complete the setting.

Using the VIEWFINDER

- ❖ The VIEWFINDER will not work when the LCD is open.

Adjusting the Focus

Use the focus adjustment knob on the VIEWFINDER to focus the picture.
(refer to diagram)

Preparation

Adjusting the LCD during PLAY

- ❖ You can adjust the LCD during playback.
- ❖ The adjustment method is the same as is used while in CAMERA mode. (See page 32)

Controlling Sound from the Speaker

The Speaker only works in PLAYER mode.

- When you use the LCD screen for playback, you can hear the recorded sound from the built-in Speaker.
 - Follow the instructions below to decrease or mute speaker volume in PLAYER mode.
 - Take the following steps to lower the volume or mute the sound while playing a tape on the camcorder.

1. Set the device to CAMCORDER and set the Power Switch to PLAYER mode.
2. Press ►/II (PLAY/STILL) to play the tape.
3. Once the tape is in play and you hear sound, use the MENU DIAL to adjust the volume.
 - A Volume Level display will appear on the LCD.
 - Levels may be adjusted from anywhere between 0 to 19. You will not hear any sound when the volume is set on 0.
 - If you close the LCD while playing, you will not hear sound from the speaker.

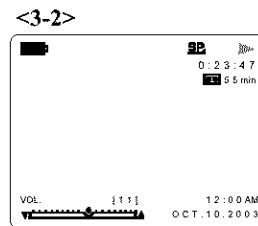
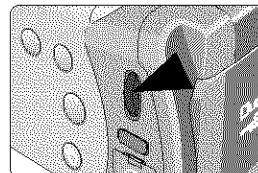
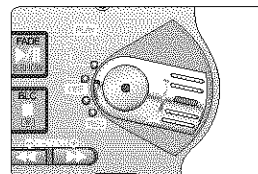

Notes

- When the cable is connected to the A/V jack, you cannot hear sound from the speaker and cannot adjust the volume.
- You can hear sound from the speaker by removing the connected cable from the A/V jack

Functions

Using MENU

- ❖ Use the MENU button to change or select recording settings and Hardware functions.
- ❖ MENU instructions are displayed both on the LCD and the viewfinder. It is easier to manipulate your device using the LCD.

MENU	SUB MENU	Functions	Page	
INITIAL	CLOCK SET	Setting the Time	41	
	WL.REMOTE	Using the Remote Control	42	
	REC.LAMP	Record Indicator	-	
	BEEP SOUND	Play Various Sound Effects	-	
	SHUT. SOUND	Sound Effect for the Photo button	-	
	DEMO	Demonstration	43	
CAMCORDER	RECORD SET	REC SELECT	Selecting the Storage Media for Camcorder mode	50
		REC MODE	Selecting the Recording Speed	62
		EIS	Selecting the Image Stabilizing Function	59
		D. ZOOM	Selecting Digital Zoom in CAMCORDER Mode	58
		PROGRAM AE	Selecting the PROGRAM AE Function	55
		WHT. BALANCE	Setting White Balance of CAMCORDER Mode	57
		DSE SELECT	Setting special effects in CAMCORDER Mode	60
		AUDIO MODE	Selecting Sound Quality for Recording	63
		WIND CUT	Removing Screen Noise	64
		AV IN/OUT	Selecting AV in/out	-

Functions

MENU	SUB MENU	Functions	Page	
CAMCORDER	PLAY SET	PHOTO SEARCH	Searching Pictures recorded in TAPE	73
		PHOTO COPY	Copying Pictures from TAPE onto the Memory Stick	109
		AUDIO SELECT	Selecting the Audio playback channel	72
CAMERA	CONT. SHOT		Continuous Shot	95
	WHT. BALANCE		Selecting White Balance in CAMERA Mode	98
	D. ZOOM		Selecting Digital Zoom in CAMERA Mode	93
	DSE SELECT		Setting special effects in CAMERA mode	99
MEMORY	M.PLAY SELECT		Selecting Storage Media to MPEG playback	107
	PHOTO SET	QUALITY	Selecting Image Quality	103
		SIZE	Selecting Image Resolution	104
	MPEG4 SIZE		Selecting MPEG Resolution	108
	PRINT MARK		Printing Images	110
	PROTECT		Preventing Accidental Erasure	111
	FILE NO		File Naming Options	86
	DELETE		Deleting Files	112
FORMAT		Formatting the Memory Stick	114	
VIEWER	LCD ADJUST		Setting the brightness and Color Tones of the LCD	32
	DATE/TIME		Setting the Date and Time	44
	TV DISPLAY		Selecting TV out	45

Functions

Setting menu items

MENU	SUB MENU		Available mode			
			REC	TAPE PLAY	MEMORY RECORD	MEM.PLAY
INITIAL	CLOCK SET		✓	✓	✓	✓
	WL.REMOTE		✓	✓	✓	✓
	REC.LAMP		✓		✓	
	BEEP SOUND		✓	✓	✓	✓
	SHUT. SOUND		✓	✓	✓	
	DEMO		✓			
CAMCORDER	RECORD SET	REC SELECT	✓			
		REC MODE	✓	✓		
		EIS	✓			
		D. ZOOM	✓			
		PROGRAM AE	✓			
		WHT. BALANCE	✓			
		DSE SELECT	✓			
		AUDIO MODE	✓	✓		
		WIND CUT	✓	✓		
		AV IN/OUT		✓		

Functions

MENU	SUB MENU		Available mode			
			REC	TAPE PLAY	MEMORY RECORD	MEM.PLAY
CAMCORDER	PLAY SET	PHOTO SEARCH		✓		
		PHOTO COPY		✓		
		AUDIO SELECT		✓		
CAMERA	CONT. SHOT				✓	
	WHT. BALANCE				✓	
	D. ZOOM				✓	
	DSE SELECT				✓	
MEMORY	M.PLAY SELECT					✓
	PHOTO SET	QUALITY		✓	✓	
		SIZE			✓	
	MPEG4 SIZE					
	PRINT MARK					✓
	PROTECT					✓
	FILE NO			✓	✓	✓
	DELETE					✓
FORMAT					✓	
VIEWER	LCD ADJUST		✓	✓	✓	✓
	DATE/TIME		✓	✓	✓	✓
	TV DISPLAY		✓	✓	✓	✓

Functions

● Setting the Camcorder to REC, TAPE PLAY, MEMORY PLAY modes

1. Press the MENU button.
2. The MENU OSD is displayed. The cursor (**HIGHLIGHT**) indicates the feature you are currently adjusting.
3. Use the MENU DIAL to move between items and press the MENU DIAL to select and activate an item.
4. You can exit Menu mode by pressing the MENU button.

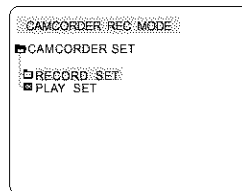
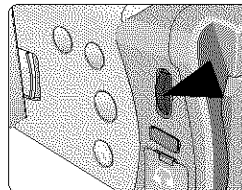

Functions

● Availability of Functions in CAMCORDER Mode.

Operating Mode	Requested Mode	Digital functions				Digital special effects	NITE PIX
		EIS	D.ZOOM	PHOTO (TAPE)	SLOW SHUTTER		
EIS		○	○	○	△	○	○
D.ZOOM		○	○	○	* △	○	○
PHOTO		×	○	○	×	○	×
SLOW SHUTTER		△	△	○	○	○	○
Digital Special Effects		○	○	○	○	○	×
NITE PIX		○	△	○	○	×	○

○ : The requested mode will work in this operating mode.

×

△ : The operating mode will be released and the requested mode will work.

* : The operating mode will be released and the requested mode will work.

(The data input while operating will be backed up)

Notes

- When a menu item on the LCD is marked with an [X], that item cannot be activated.
- When you select an item that cannot be changed, an error message will be displayed.

Functions

● CLOCK SET

- ❖ CLOCK setup works in CAMCORDER or CAMERA modes.
- ❖ The DATE/TIME is automatically recorded onto the tape and Memory Stick.
Before recording or taking photos, please set the DATE/TIME.

1. Press the MENU button.
 - The menu list will appear.
2. Turn the MENU DIAL to highlight INITIAL and press the MENU DIAL.
3. Use the MENU DIAL to select CLOCK SET from the sub-menu.
4. Press the MENU DIAL to enter SETTING mode.
 - A blinking item indicates the item can be changed. The year will blink first.
5. Using the MENU DIAL, change the year setting.
6. Press the MENU DIAL.
 - The month will blink.
7. Using the MENU DIAL, change the month setting.
8. Press the MENU DIAL.
 - The day will blink.
9. You can set the day, hour and minute following the same procedure for setting the year and month.
10. Press the MENU DIAL after setting the minutes.
 - The word COMPLETE! will appear, and a few seconds later, the menu screen will automatically return to the sub menu.
11. To exit, press the MENU button.

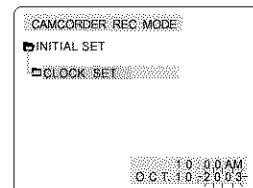
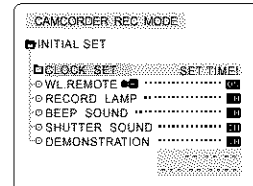
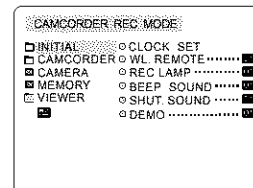

Functions

● WL.REMOTE

- ❖ The WL.REMOTE function works in CAMCORDER or CAMERA modes.
- ❖ The WL.REMOTE option allows you to enable or disable the remote control for use in CAMCORDER and CAMERA modes.

1. Press the MENU button.
 - The menu list will appear.
2. Turn the MENU DIAL to highlight INITIAL and press the MENU DIAL.
3. Use the MENU DIAL to select WL.REMOTE from the sub-menu.
4. Press the MENU DIAL to enable or disable the remote control.

The setting switches between ON/OFF each time you press the MENU DIAL.
5. To exit, press the MENU button.
 - If you set the remote to OFF in the menu and try to use it, the remote control icon will blink for 3 seconds and disappear on the LCD.

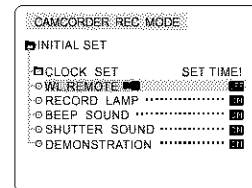
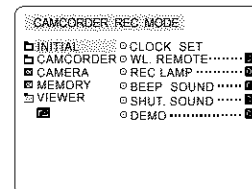

Functions

● DEMONSTRATION

- ❖ Demonstration automatically shows you the major functions that are included with your camcorder so that you may use them more easily.
- ❖ The DEMONSTRATION function may only be used in the CAMCORDER mode without a tape inserted in the camcorder.
- ❖ The demonstration operates repeatedly until the DEMONSTRATION mode is switched OFF.

1. Set the device to CAMCORDER and set the power switch to REC mode.
2. Press the MENU button.
 - The menu list will appear.
3. Turn the MENU DIAL to highlight INITIAL.
4. Select DEMONSTRATION from the submenu and press the MENU DIAL.
5. To activate the DEMONSTRATION, set DEMONSTRATION to ON.
 - Press the menu button to quit the menu.
 - The demonstration will begin.
6. To end the DEMONSTRATION, set the DEMONSTRATION to OFF.

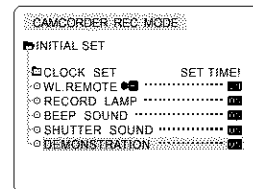
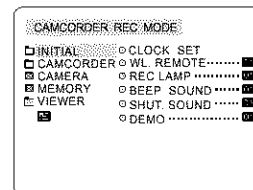

Notes

- The DEMONSTRATION function only works when there is no TAPE installed.
- The DEMONSTRATION mode is automatically activated when the camcorder is left idle for more than 10 minutes after switching to CAMCORDER mode (when no tape is inserted in the camcorder).
- If you press other buttons (FADE, BLC, PHOTO, EASY) during the DEMONSTRATION mode, the DEMONSTRATION stops temporarily and resumes 10 minutes later if you do not operate any other functions.

Functions

● DATE/TIME

- ❖ The DATE/TIME function works in CAMRECORDER or CAMERA mode and PLAY modes.
- ❖ The date and time are automatically recorded on a special data area of the tape.

1. Press the MENU button.
 - The menu list will appear.
2. Turn the MENU DIAL to highlight VIEWER and press the MENU DIAL.
3. Turn the MENU DIAL to highlight DATE/TIME.
4. Press the MENU DIAL to select the sub-menu.
5. Using the MENU DIAL, select DATE/TIME mode.
 - You can choose to display - OFF, DATE, TIME, DATE/TIME
 - OFF
 - DATE only
 - TIME only
 - DATE & TIME
 - To return to the previous menu, highlight the DATE/TIME in the middle and press the MENU DIAL.
6. To exit, press the MENU button.

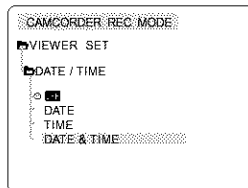
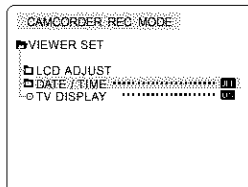
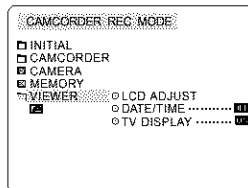

Notes

- The DATE/TIME is not affected by the OSD ON/OFF (DISPLAY) button.
- The DATE/TIME will read "--" in the following conditions.
 - During playback of a blank section of a tape.
 - If the tape was recorded before setting the DATE/TIME in the Camera's memory.
 - When the lithium battery becomes weak or dead.
- Before you can use the DATE/TIME function, you must set the Clock. See CLOCK SET on page 41.

Functions

● TV DISPLAY

- ❖ The TV DISPLAY function works in CAMCORDER or CAMERA modes.
 - ❖ You can select the output path of the OSD (On Screen Display).
 - OFF: The OSD appears on the LCD screen only.
 - ON: The OSD appears on the LCD screen, EVF and TV.
 - Use the DISPLAY button located on the left side of the camcorder to turn ON/OFF all of the OSD displayed on the LCD/EVF/TV.
1. Set the Power switch to REC or PLAY modes.
 2. Press the MENU button.
 - The menu list will appear.
 3. Turn the MENU DIAL to highlight VIEWER and press the MENU DIAL.
 4. Select TV DISPLAY mode from the list, press the ENTER button.
 - The DISPLAY mode switches between ON/OFF with each push.
 5. To exit, press the MENU button.

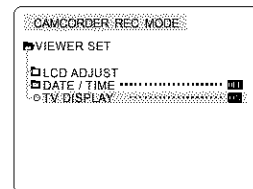
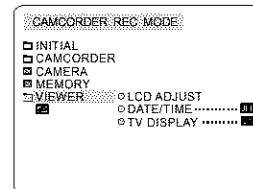

Functions

EASY Mode (for Beginners)

- ❖ The EASY mode allows a beginner to easily make good recordings.
 - The EASY mode only operates in CAMCORDER and CAMERA modes.
1. Set the Power Switch to REC mode.
 2. By pressing the EASY button, all functions on the camera will be set to OFF and the recording settings will be set to the following basic modes:
 - Battery level, recording mode, counter, DATE/TIME, and EIS () will be displayed.
 - The word "EASY.Q" will appear on the LCD at the same time.
However, the DATE/TIME will only be seen if it has been previously set. (See page 44)
 3. Press the START/STOP or PHOTO button to start recording.
 - Recording will begin using the basic automatic settings.
 4. Press the EASY button again to turn EASY mode off.
 - The EASY function will not turn off when you are recording.
 - The camera will return to the settings that were set prior to activating EASY mode.

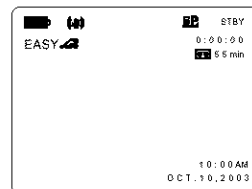
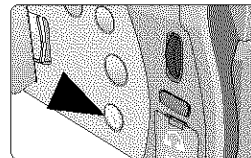

Notes

- In EASY mode, certain functions are not available, such as MENU, FADE, BLC, MF/AF.
 - If you want to use these functions, you must first turn EASY mode off.
- The EASY mode settings are deleted when the battery pack is uninstalled from the camcorder and therefore, they must be reset when a battery pack has been replaced.

Functions

MF/AF (Manual Focus/Auto Focus)

- ❖ The MF/AF function works in CAMCORDER and CAMERA modes.
- ❖ In most situations, it is better to use the automatic focus feature, as it enables you to concentrate on the creative side of your recording.
- ❖ Manual focusing may be necessary under certain conditions that make automatic focusing difficult and/or unreliable.

Auto Focusing

- ❖ In CAMCORDER Mode, turning on the device will set it to automatic focus . In CAMERA Mode, pressing the Photo Button halfway down will set the focus.

Manual Focusing

- ❖ In the following cases you may obtain better results by adjusting the focus manually.
 - a. A picture containing several objects, some close to the camcorder, others further away.
 - b. A person enveloped in fog or surrounded by snow.
 - c. Very shiny or glossy surfaces like a car.
 - d. People or objects moving constantly or quickly like an athlete or a crowd.
 1. Set the Power Switch to REC mode.
 2. Press the MF Button.
 - MF Icon() is displayed on the LCD screen.
 3. Turn the MENU DIAL up or down until the object is in focus.
 - Zoom out a little if focusing is difficult.
 4. To return to AF, press the MF Button again.

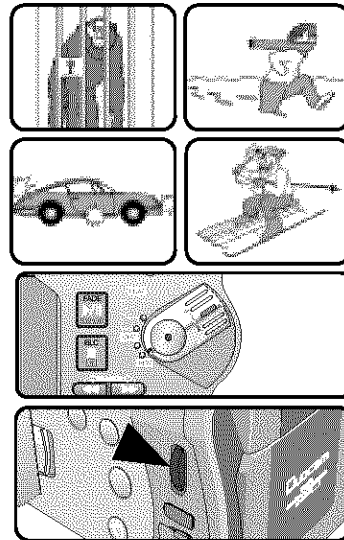

Functions

Zooming In and Out with DIGITAL ZOOM

- ❖ The Zoom works in CAMCORDER and CAMERA modes.

Zooming In and Out

- ❖ Zooming is a recording technique that lets you change the size of the subject in a scene. For more professional looking recordings, do not use the zoom function too often.
- ❖ You can zoom using variable zoom speeds.
- ❖ Use these features for different shots. Please note that over-use of the zoom feature can lead to unprofessional looking results and a reduction of battery usage time.

1. Move the zoom lever slowly for a gradual zoom, move it faster for a high-speed zoom.
Your zooming can be monitored on the OSD.
2. T(Telephoto) side: Subject appears closer.
3. W(Wide angle) side: Subject appears farther away.

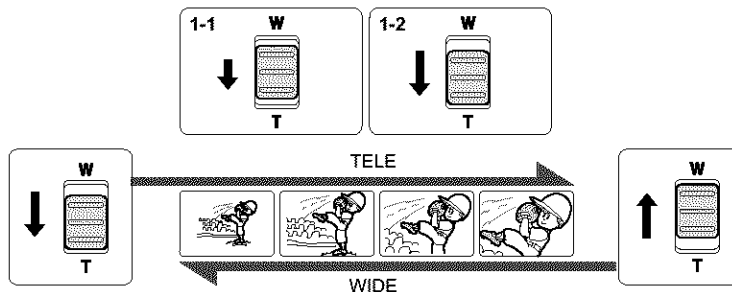

Note

You can record a subject that is a minimum of 1 m (about 2.65 feet) away from the lens surface in the TELE position, or about 10 mm (about 0.5 inch) away in the WIDE position.

Using the CAMCORDER - Basic Recording

Inserting and Ejecting a Cassette

- ❖ When inserting a tape or closing the cassette holder, do not apply excessive force. This may cause a malfunction.
 - ❖ Do not use any tapes other than Mini DV cassettes.
1. Connect a power source. Slide the TAPE OPEN/EJECT switch and open the cassette door.
 - The cassette holding mechanism rises automatically.
 2. Insert a tape into the cassette holder with the tape window facing outward and the protection tab toward the top.
 3. Press the area labelled PUSH on the cassette holding mechanism until it clicks into place.
 - The cassette is loaded automatically.
 4. Close the cassette door.
 - Close the door completely until you can hear a "click".

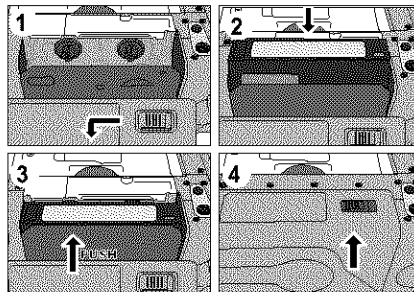

Notes

When you have recorded something that you wish to keep, you can protect it so that it will not be accidentally erased.

a. Protecting a Tape :

Push the safety tab on the cassette so that the hole is uncovered.

b. Removing the protection from a tape :

If you no longer wish to keep the recording on the cassette, push the write-protect tab back so that it covers the hole.

• How to Store a Tape

- a. Avoid places with magnets or magnetic interference.
- b. Avoid humidity and dust prone places.
- c. Keep the tape in an upright position and avoid storing it in direct sunlight.
- d. Avoid dropping or knocking your tapes.

a. SAVE



b. REC



Using the CAMCORDER - Basic Recording

To select the CAMCORDER mode

- ❖ You can select either a tape or the Memory Stick as the storage media for motion clips.
- ❖ Use M.Play mode to view the motion clips stored on the Memory Stick.

1. Set the device to CAMCORDER and set the power switch to REC mode.
2. Press the MENU button.
 - The menu list will appear.
3. Turn the MENU DIAL highlight to CAMCORDER and press the MENU DIAL.
 - The sub-menu list will appear.
4. Select RECORD SET from the sub-menu and press the MENU DIAL.
5. Turn the MENU DIAL to activate REC SELECT, press the MENU DIAL.
 - CAMCORDER mode toggles between TAPE and MEMORY with each press.
6. The menu list will disappear.

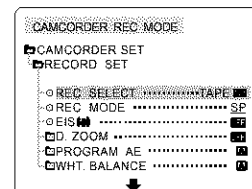
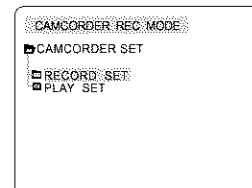
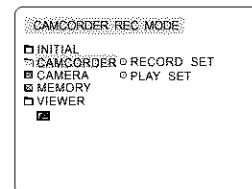

Using the CAMCORDER - Basic Recording

Making Your First Recording

1. Connect a Power source to the camcorder.
(See page 26)
(A battery pack or the AC power adapter)
 - Insert a cassette. (See page 49)
2. Set the device to CAMCORDER and set the power switch to REC mode.
 - Open the LCD monitor.
 - If the protection tab of the cassette is open, the words STOP and PROTECTION! will be displayed.
 - Make sure the image you want to record appears on the LCD monitor or viewfinder.
 - Make sure the battery level indicates that there is enough remaining power for your expected recording time.
3. To start recording, press the START/STOP button.
 - REC is displayed on the LCD.
To stop recording, press the START/STOP button again.
 - STBY is displayed on the LCD.

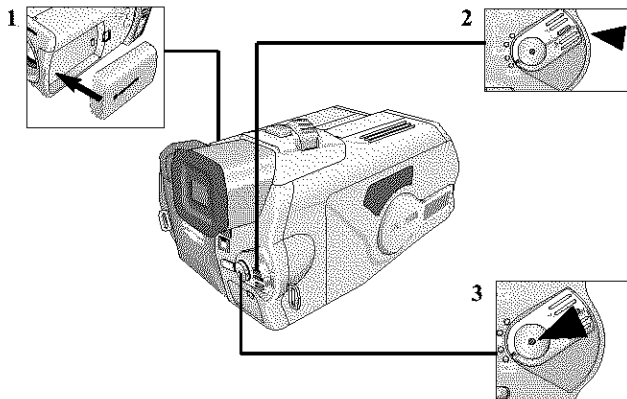

Using the CAMCORDER - Basic Recording

When a cassette is loaded and the camcorder is left in the STBY mode for more than 5 minutes without being used, it will automatically turn off.

To use it again, push the START/STOP button or set the Power switch to OFF and then back to CAMERA.

This Auto Power Off feature is designed to save battery power.

Record Search (REC SEARCH)

- ❖ You can view a recording using the REC SEARCH +, - function in STBY mode. REC SEARCH - enables you to play the recording backwards and REC SEARCH + enables you to play it forwards, for as long as you keep each button pressed down.
- ❖ If you press the REC SEARCH - button in STBY mode, your camcorder will play in reverse for 3 seconds and return to the original position automatically.

Note

Mosaic shaped distortion may appear on the screen while in Record Search mode.

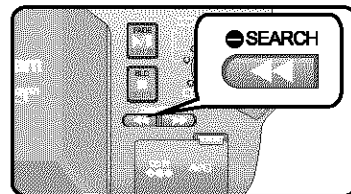
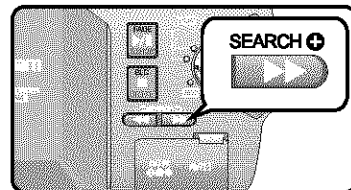

Using the CAMCORDER - Basic Recording

Hints for Stable Image Recording

- ❖ When recording, it is very important to hold the camcorder correctly.
- ❖ Fix the LENS cap firmly by clipping it to the hand strap. (refer to the diagram)

Recording with the LCD Monitor

1. Hold the camcorder firmly using the hand strap.
2. Place your right elbow against your side.
3. Place your left hand under or beside the LCD to support and adjust it.
Do not touch the built-in microphone.
4. Choose a comfortable, stable position for the shots that you are taking.
You can lean against a wall or on a table for greater stability.
Do not forget to breathe gently.
5. Use the LCD frame as a guide to determine the horizontal plane.
6. Whenever possible, use a tripod.

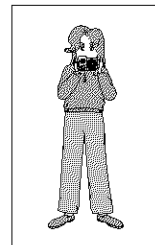

Recording with the Viewfinder

1. Hold the camcorder firmly using the hand strap.
2. Place your right elbow against your side.
3. Place your left hand under the camcorder to support it.
Be sure not to touch the built-in microphone.
4. Choose a comfortable, stable position for the shots that you are taking.
You can lean against a wall or on a table for greater stability.
Do not forget to breathe gently.
5. To view an object through the viewfinder, pull it out until you hear a 'click' sound.
Pulling with excessive force may cause damage to the viewfinder.
6. Place your eye firmly against the viewfinder eyecup.
7. Use the viewfinder frame as a guide to determine the horizontal plane.
8. Whenever possible, use a tripod.

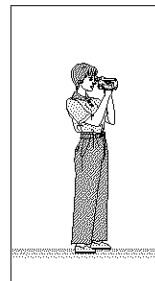

Using the CAMCORDER - Basic Recording

Playing Back a Tape You Have Recorded on the LCD

- ❖ You can monitor the playback picture on the LCD monitor.
- ❖ Make sure that the battery pack is in place.

1. Set the device to CAMCORDER and the Power Switch to PLAY mode.
2. Insert the tape you wish to view. (See page 49)
3. Open the LCD screen.
Adjust the angle of the LCD screen and set the brightness or color if necessary.
4. Press the ◀◀ (REW) button to rewind the tape to the starting point.
 - To stop rewinding, press the ■ (STOP) button.
 - The camcorder stops automatically after rewinding is complete.
5. Press the ▶▶ (PLAY/STILL) button to start the playback.
 - You can view the pictures you recorded on the LCD.
 - To stop the PLAY operation, press the ■ (STOP) button.

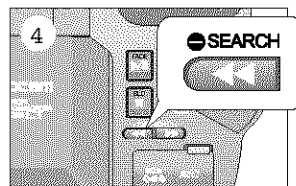
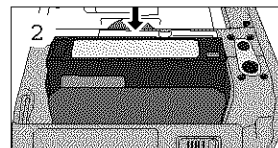
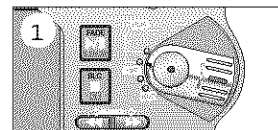

Notes

- You can also view the picture on a TV screen, after connecting the camcorder to a TV or VCR. (See page 77)
- Various functions are available in Playback mode. (See page 79)

Using the CAMCORDER - Advanced Recording

● PROGRAM AE

- ❖ The PROGRAM AE function works in CAMCORDER mode only.
- ❖ PROGRAM AE mode allows you to adjust shutter speeds and apertures to suit different recording conditions.
- ❖ It gives you creative control over the depth of field.

■ AUTO Mode

- Auto balance between the subject and the background.
- To be used in normal conditions.
- The shutter speed automatically varies from 1/60 to 1/250 per second, depending on the scene.

■ SPORTS Mode (⚡)

- For recording people or objects which are moving quickly.

■ PORTRAIT Mode (👤)

- For focusing on the background of a subject, when the background is out of focus.
- PORTRAIT mode is most effective when used outdoors.
- The shutter speed automatically varies from 1/60 to 1/1000 per second.

■ SPOTLIGHT Mode (🎯)

- For proper recording when there is only light on the subject and not the rest of the picture.

■ SAND/SNOW Mode (🏖️)

- For recording when people or objects are darker than the background because of reflected light from sand or snow.

■ High S. SPEED(High Shutter Speed) Mode (👤)

- For recording fast-moving subjects such as players in golf or tennis games.

Using the CAMCORDER - Advanced Recording

Setting PROGRAM AE

1. Press the MENU button.
 - The menu list will appear.
2. Turn the MENU DIAL to highlight CAMCORDER and press the MENU DIAL.
3. Select PROGRAM AE from the sub-menu.
4. Press the MENU DIAL to enter the sub-menu.
5. Using the MENU DIAL, select one of the PROGRAM AE modes.
 - Press the MENU DIAL to confirm the Program AE mode you have selected.
6. To exit, press the MENU button.

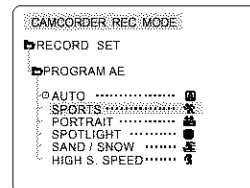
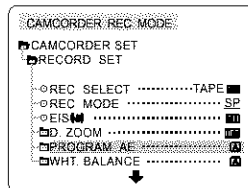
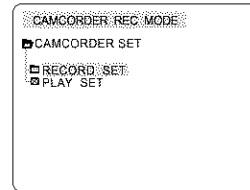
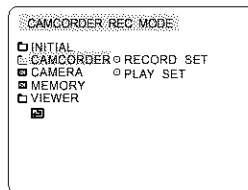

Using the CAMCORDER - Advanced Recording

● WHT. BALANCE (WHITE BALANCE) - CAMCORDER Mode

- ❖ The WHITE BALANCE function in CAMCORDER mode is a recording function that preserves the unique color of the object under any recording condition.
- ❖ You may select the appropriate WHITE BALANCE mode to obtain high quality color in the image.
 - AUTO (☐) : This mode is generally used to control the WHITE BALANCE automatically.
 - HOLD (↓) : This fixes the current WHITE BALANCE value.
 - INDOOR (♣) : This controls the WHITE BALANCE according to indoor ambience.
 - OUTDOOR (✱) : This controls the WHITE BALANCE according to outdoor ambience.

1. Set the camcorder to CAMERA mode.
2. Press the MENU button.
 - The menu list will appear.
3. Turn the MENU DIAL to highlight CAMCORDER and press the MENU DIAL.
4. Select WHT.BALANCE from the submenu.
5. Press the ENTER button to enter the sub-menu.
6. Using the MENU DIAL, select the WHITE BALANCE function you wish to use.
 - Press the ENTER button to confirm the WHITE BALANCE function you have selected.
7. To exit, press the MENU button.

Notes

- While setting NITE PIX to ON, the WHT.BALANCE function does not work.
- The WHT.BALANCE function will not operate in EASY mode.
- Turn the Digital Zoom off (if necessary) to set a more accurate White Balance.
- If you have set the White Balance and the lighting conditions change, reset the White Balance.
- For normal outdoor recording, setting the White Balance to AUTO may provide the best results.

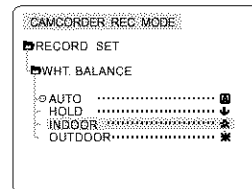
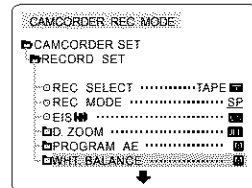
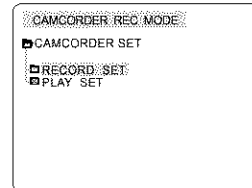
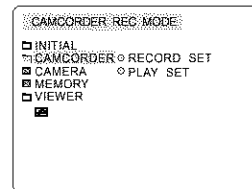

Using the CAMCORDER - Advanced Recording

Digital Zoom in CAMCORDER Mode

- ❖ Zooming more than 10x is achieved digitally.
- ❖ The picture quality may deteriorate depending on how much you zoom in on the subject.
- ❖ We recommend that you use the EIS feature with DIGITAL ZOOM for picture stability. (See page 59)

1. Set the power switch to CAMCODER or CAMERA mode.
2. Press the MENU button.
 - The menu list will appear.
3. Turn the MENU DIAL to CAMCORDER and press the MENU DIAL.
4. Select RECORD SET from the sub-menu and press the MENU DIAL.
5. Select D.ZOOM from the sub-menu.
6. Press the MENU DIAL to setup the 100x, 200x, 400x, 800x digital zoom function or to turn the feature OFF.
7. To exit, press the MENU button.

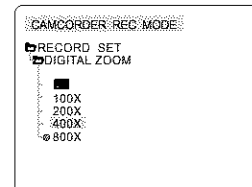
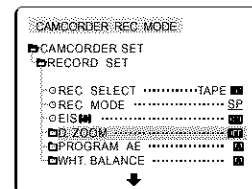
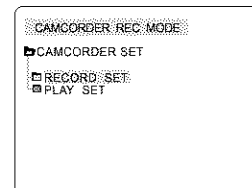
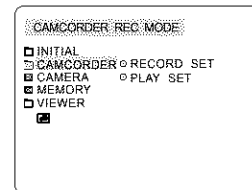

Using the CAMCORDER - Advanced Recording

● EIS (Electronic Image Stabilizer)

- ❖ The EIS function works in CAMCORDER mode only.
- ❖ EIS (Electronic Image Stabilizer) is a function that compensates for any shaking or hand movement while holding the camcorder (within reasonable limits).
- ❖ It provides more stable pictures when:
 - Recording with the zoom
 - Recording a small object close-up
 - Recording and walking at the same time
 - Recording through the window of a vehicle

1. Set the device to CAMCORDER and set the power switch to REC mode.
2. Press the MENU button.
 - The menu list will appear.
3. Turn the MENU DIAL highlight to CAMCORDER and press the MENU DIAL.
 - The sub-menu list will appear.
4. Select RECORD SET from the sub-menu and press the MENU DIAL.
5. Turn the MENU DIAL to activate the EIS function, then press the MENU DIAL.
 - The EIS menu is changed to ON.
 - If you do not want to use the EIS function, set the EIS menu to OFF.
6. To exit, press the MENU button.

Note

- It is recommended that you deactivate the shake compensation function when using a tripod.

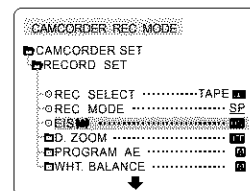
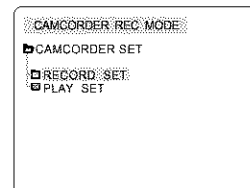
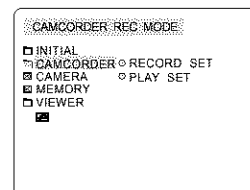

Using the CAMCORDER - Advanced Recording

● DSE(Digital Special Effects) SELECT in CAMCORDER Mode

- ❖ The DSE function works in CAMCORDER mode only.
- ❖ The digital effects enable you to give a creative look to your recording by adding various special effects.
- ❖ Select the appropriate digital effect for the type of picture that you wish to record and the effect you wish to create.
- ❖ There are 9 DSE modes.

a. ART Mode

This mode gives the images a coarse effect.

b. MOSAIC Mode

This mode gives the images a mosaic effect.

c. SEPIA Mode

This mode gives the images a reddish-brown pigment.

d. NEGA Mode

This mode reverses the colors of the images, creating a negative image.

e. MIRROR Mode

This mode cuts the picture in half, using a mirror effect.

f. BLK & WHT Mode

This mode changes the images to black and white.

g. EMBOSS Mode

This mode creates a 3D effect (embossing).

h. CINEMA Mode

This mode covers the upper/lower portions of the screen to create a cinematic effect.

i. MAKE - UP Mode

This mode allows the images to be colored red, green, blue or yellow.

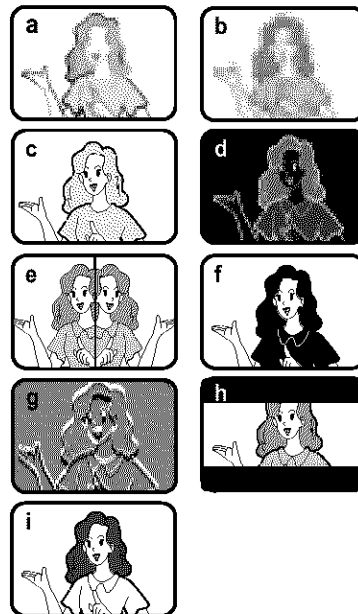

Using the CAMCORDER - Advanced Recording

Selecting a Digital Effect in CAMCORDER Mode

1. Set the device to CAMCORDER and set the power switch to REC mode.
2. Press the MENU button.
 - The menu list will appear.
3. Turn the MENU DIAL to highlight CAMCORDER and press the MENU DIAL.
4. Select RECORD SET from the sub-menu and press the MENU DIAL.
5. Select DSE SELECT from the sub-menu.
6. Press the MENU DIAL to enter the sub-menu.
7. Using MENU DIAL, select the DSE mode you wish to use.
 - Press the MENU DIAL to confirm the DSE mode you have selected.
8. To exit, press the MENU button.

Notes

- While setting NITE PIX to ON, the DSE function does not work.
- The DSE function will not operate in EASY mode.

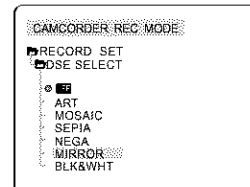
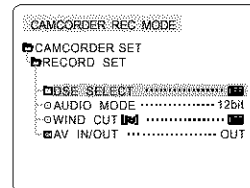
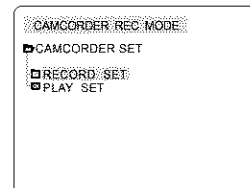
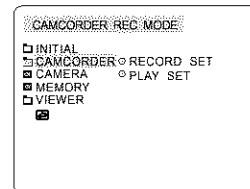

Using the CAMCORDER - Advanced Recording

● REC MODE

- ❖ The REC MODE function works in both CAMCORDER and PLAY(DV IN) modes.
- ❖ This camcorder records and plays back in SP (standard play) mode and in LP (long play) mode.
 - SP (standard play): This mode permits 60 minutes of recording time with a DVM60 tape.
 - LP (long play): This mode permits 90 minutes of recording time with a DVM60 tape.

1. Set the device to CAMCORDER and set the power switch to REC mode.
2. Press the MENU button.
 - The menu list will appear.
3. Turn the MENU DIAL to highlight CAMCORDER and press the MENU DIAL.
4. Select RECORD SET from the sub-menu and press the MENU DIAL.
5. Turn the MENU DIAL to highlight REC MODE and press the MENU DIAL.
6. Select REC MODE from the sub-menu and press the MENU DIAL.
 - The REC MODE toggles between SP and LP with each press.
7. To exit, press the MENU button.

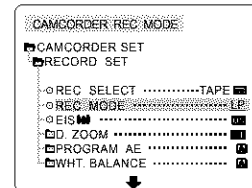
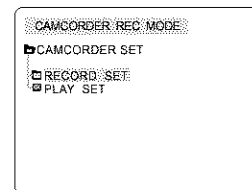
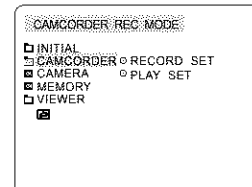

Notes

- We recommend that you use this camcorder to play back any tapes recorded on this camcorder. Playing back a tape recorded in other equipment may produce mosaic shaped distortion.
- When you record a tape in SP and LP modes, or LP mode only, the playback picture may be distorted or the time code may not be written properly between scenes.
- Record using SP mode for the best picture and sound quality.

Using the CAMCORDER - Advanced Recording

● AUDIO MODE

- ❖ The AUDIO MODE function works in CAMCORDER mode.
- ❖ This camcorder records sound in two ways. (12bit, 16bit)
 - 12bit : You can record two 12bit stereo sound tracks.
The original stereo sound can be recorded onto the MAIN (SOUND1) track.
Additional stereo sound can be dubbed onto the SUB (SOUND2) track.
 - 16bit : You can record one high quality stereo sound using the 16bit recording mode.
Audio dubbing is not possible when using this mode.

1. Set the device to CAMCORDER and set the power switch to REC mode.
2. Press the MENU button.
 - The menu list will appear.
3. Turn the MENU DIAL to highlight CAMCORDER and press the MENU DIAL.
4. Select RECORD SET from the sub-menu and press the MENU DIAL.
5. Turn the MENU DIAL to highlight AUDIO MODE and press the MENU DIAL.
6. Select the AUDIO MODE you wish to use from the menu then press the MENU DIAL.
 - The AUDIO MODE toggles between 12bit-16bit with each press of the dial.
7. To exit, press the MENU button.

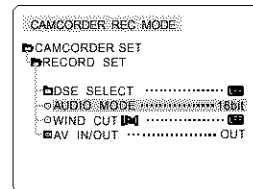
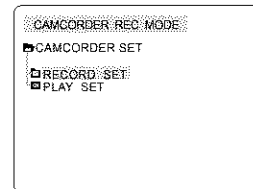
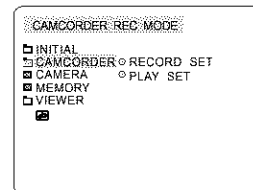

Using the CAMCORDER - Advanced Recording

● WIND CUT

- ❖ The WIND CUT function works in CAMCORDER, and PLAY modes.
- ❖ The WIND CUT function minimizes wind noise or other noise while recording.
 - When the wind cut is on, some low sounds are eliminated along with the sound of the wind.

1. Set the device to CAMCORDER and set the power switch to REC mode.
2. Press the MENU button.
 - The menu list will appear.
3. Turn the MENU DIAL to highlight CAMCORDER and press the MENU DIAL.
4. Select RECORD SET from the sub-menu and press the MENU DIAL.
5. Turn the MENU DIAL to highlight WIND CUT and press the MENU DIAL.
6. This feature toggles ON/OFF each time you press the MENU DIAL.
7. To exit, press the MENU button.

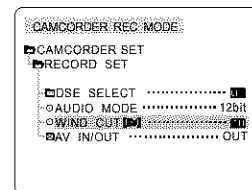
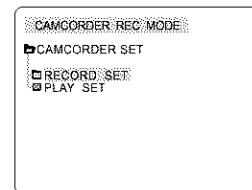
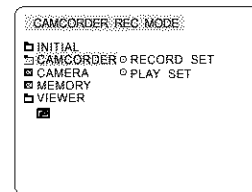

Notes

- Make sure WIND CUT is set to OFF when you want the microphone to be as sensitive as possible.
- Use the WIND CUT when recording in windy places such as the beach or near buildings.

Using the CAMCORDER - Advanced Recording

Using Quick Menu(Navigation Menu)

- ❖ Quick Menu is available only in CAMCORDER mode.
- ❖ Quick Menu is used to adjust camera functions by simply using the MENU SELECTOR dial.
This feature is useful for when you want to make simple adjustments without having to access the menus and sub-menus.

- **DATE/TIME**
 - Each time you select DATE/TIME and press the MENU DIAL, it will be displayed in the order of DATE - TIME - DATE/TIME - OFF(See page 50).

- **WL.REMOTE(📶)**
 - Each time you select WL.REMOTE and press the MENU DIAL, the WL.REMOTE is switched to either enabled (📶) or disabled (🚫) .

- **EIS(📵)**
 - Each time you select EIS and press the MENU DIAL, the EIS icon is displayed or set to OFF.

- **DSE(Digital Special Effect) (See page 60)**
 - Each time you select DSE and press the MENU DIAL, the DSE preset values are applied or set to OFF.
DSE values will not switch between ON and OFF if they have not been preset in the menu.

- **PROGRAM AE (See page 55)**
 - Each time you select PROGRAM AE and press the MENU DIAL, you can choose between the preset PROGRAM AE value and AUTO. You can't choose between AUTO and the PROGRAM AE value if the value has not been preset in the regular menu.

Using the CAMCORDER - Advanced Recording

■ WHT. BALANCE (See page 57)

- Each time you select WHT. BALANCE and press the MENU DIAL, you can choose between the preset WHT.BALANCE value and AUTO. As in PROGRAM AE, you can't choose between AUTO and- WHT.BALANCE value if it has not been preset..

■ FOCUS (Manual Focus/Auto Focus) (See page 47)

- Each time you select FOCUS and press the MENU DIAL, the FOCUS is switched to either Manual Focus (MF) or Auto Focus.

■ SHUTTER SPEED & EXPOSURE



- You can set values for SHUTTER SPEED and EXPOSURE by selecting the () icon and pressing the MENU DIAL. For more information, see the next chapter.

Setting the Quick Menu

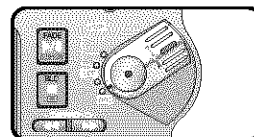
1. Set the device to CAMCORDER and set the power switch to REC mode.
2. Turn the MENU DIAL to select a function you want and then press the MENU DIAL to change the values.



Notes

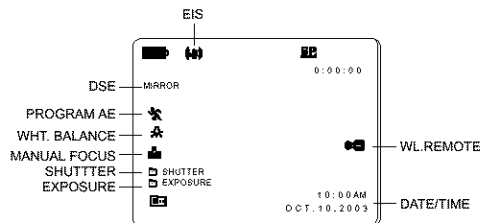

- The Quick Menu function will not operate in EASY mode.
- If you are using the Manual FOCUS() function, you cannot use the Quick Menu. If you want to use the Quick Menu function, exit the Manual FOCUS() mode.



Using the CAMCORDER - Advanced Recording

SHUTTER SPEED & EXPOSURE

- ❖ You can set SHUTTER SPEED and EXPOSURE only in CAMCORDER mode.
- ❖ SHUTTER SPEED and EXPOSURE values can only be set in the Quick Menu.
- ❖ SHUTTER SPEED and EXPOSURE are automatically switched and/or deactivated.

1. Set the device to CAMCORDER and set the power switch to REC mode.
2. Turn the MENU DIAL until you see icon() on, and then press the MENU DIAL.
 - You see a screen on which you can select SHUTTER SPEED and EXPOSURE.
 - Turn the MENU DIAL to select the item you want and then press the MENU DIAL.
 - SHUTTER SPEED can be set to 1/60, 1/100, 1/250, 1/500, 1/1000, 1/2000, 1/4000 or 1/10000.
 - EXPOSURE can be set between 00 and 29.
3. To exit from the setting screen, select the icon() and press the MENU DIAL.

Notes

- If you want to use the selected shutter speed and exposure value, you should begin the recording with the shutter speed and the exposure adjustment screens displayed on the LCD.
- If you manually change the shutter speed and the exposure value when Auto-exposure option is selected, manual changes are applied first.

Using the CAMCORDER - Advanced Recording

SLOW SHUTTER (Low Shutter Speed)

- ❖ The SLOW SHUTTER function works in CAMCORDER mode only.
 - ❖ The shutter speed can be controlled, allowing you to record slow moving objects.
1. Set the device to CAMCORDER and set the power switch to REC mode.
 2. Press the SLOW SHUTTER button.
 3. Each time you press the SLOW SHUTTER button, SHUTTER SPEED is changed between $s1/30$, $s1/15$, $s1/8$, and OFF.
 4. To exit, press the SLOW SHUTTER button.

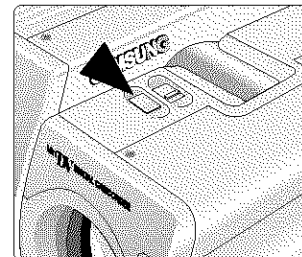

Note

- When using "SLOW SHUTTER" the image takes on a slow motion like effect.

Using the CAMCORDER - Advanced Recording

BLC (Back Light Compensation)

- ❖ BLC works in CAMCORDER mode only.
- ❖ Back lighting exists when the subject is darker than the background. For example:
 - The subject is in front of a window.
 - The person to be recorded is wearing white or shiny clothes and is placed against a bright background; the person's face is too dark to distinguish his/her features.
 - The subject is outdoors and the background is overcast.
 - The light sources are too bright.
 - The subject is against a snowy background.

1. Set the device to CAMCORDER.
2. Set the power switch to REC mode.
3. Press the BLC(STOP) button.
 - Normal - BLC - Normal
 - BLC enhances the subject.

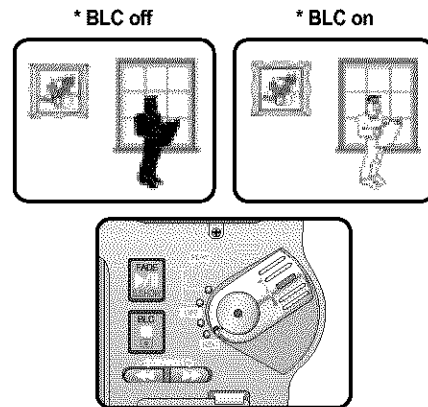

Notes

- While setting NITE PIX to ON, the BLC function does not work.
- The BLC function will not operate in EASY mode.

Using the CAMCORDER - Advanced Recording

Fade In and Out

- ❖ The FADE function works in CAMCORDER and CAMERA modes.
- ❖ You can give your recordings a professional look by using special effects such as fading in at the beginning of a sequence or fading out at the end of a sequence.

To Start Recording

1. Before recording, hold down the FADE button. The picture and sound gradually disappear (Fade Out).
2. Press the START/STOP button and at the same time release the FADE button. Recording starts and the picture and sound gradually appear (Fade In).

To Stop Recording (Using FADE IN / FADE OUT)

3. When you wish to stop recording, hold down the FADE button. The picture and sound gradually disappear (fade out).
4. When the picture has disappeared, press the START/STOP button to stop recording.

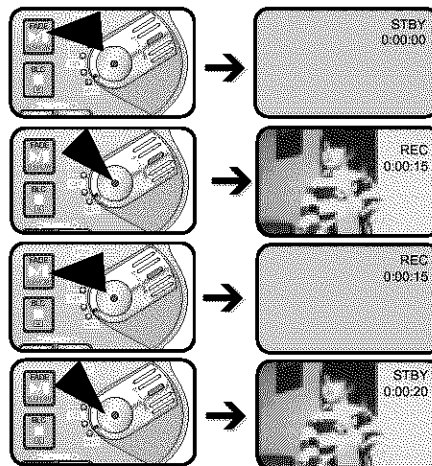

a. FADE OUT (Approx. 4 seconds)

b. FADE IN (Approx. 4 seconds)

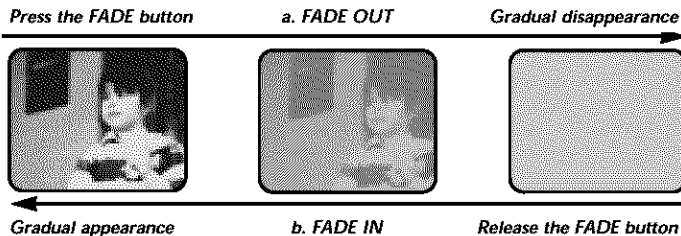

Using the CAMCORDER - Advanced Recording

Audio Dubbing

- ❖ The AUDIO DUBBING function only works in PLAYER Mode.
- ❖ You can add sound to the original sound on a pre-recorded tape, recorded in SP mode with 12bit sound.
- ❖ Use the internal and external microphones or other audio equipment.
- ❖ The original sound will not be erased.

Dubbing Sound

1. Set the device to CAMCORDER.
 - If you want to use an external microphone, connect the microphone to the external MIC input jack on the camcorder.
2. Set the power switch to PLAY mode.
 - If you want to use an external microphone, connect the microphone to the external MIC input jack on the camcorder.
3. Press the ►/|| (PLAY/STILL) button and find the time frame of the scene to be dubbed.
4. Press the ►/|| (PLAY/STILL) button to pause the scene.
5. Press the A.DUB button on the Remote Control.
 - A.DUB will be displayed on the LCD.
 - The camcorder is in a ready-to-dub state for dubbing.
6. Press the ►/|| (PLAY/STILL) button to start dubbing.
 - Press the ■ (STOP) button to stop the dubbing.

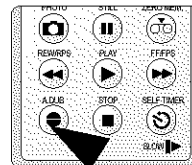
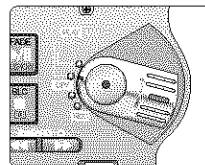
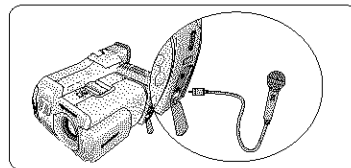

Using the CAMCORDER - Advanced Recording

Dubbed Audio Playback

1. Insert the dubbed tape and press the MENU button.
2. Turn the MENU DIAL to highlight CAMCORDER.
3. Press the MENU DIAL to enter the sub-menu.
4. Select PLAY SET and press the MENU DIAL.
5. Use the MENU DIAL to select AUDIO SELECT from the sub-menu.
6. Press the MENU DIAL to enter the sub-menu.
7. Using the MENU DIAL, select the AUDIO playback channel.
 - Press the MENU DIAL to confirm the audio playback channel.
 - SOUND1 : play the original sound.
 - SOUND2 : play the dubbed sound.
 - MIX(1+2) : play back with SOUND1 and 2 equally mixed.
8. To exit, press the MENU button.
9. Press the ►/|| (PLAY/STILL) button to playback the dubbed tape.

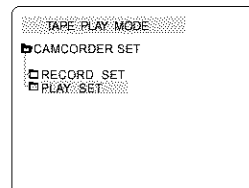
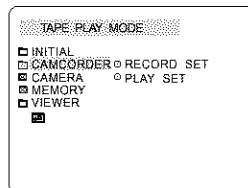

Note

- When you playback added sound (SOUND2 or MIX mode), you may experience some loss of sound quality.

Using the CAMCORDER - Advanced Recording

PHOTO Image Recording

1. Press the PHOTO button half way down and hold it.
 - The still picture appears on the LCD monitor.
 - If you do not wish to record, release the button.
2. Release the PHOTO button and press the PHOTO button again.
 - The still picture is recorded for about 6~7 seconds.
3. After the PHOTO has been recorded, the camcorder returns to STBY mode.

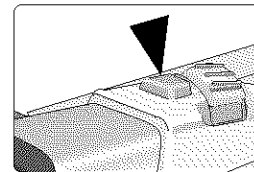

Note

- To take a quick photo, press the PHOTO button all the way down. The still picture is recorded for 6-7 seconds.

Searching for a PHOTO Picture

- ❖ The PHOTO SEARCH works in TAPE PLAY mode.
1. ■ Press the MENU button.
 - The MENU list will appear.
 2. Turn the MENU DIAL to highlight CAMCORDER and press the MENU DIAL.
 3. Select PLAY SET and press the MENU DIAL to enter the sub-menu.
 4. Select PHOTO SEARCH from the sub-menu and press the MENU DIAL.
 5. Search for the PHOTO using the ►► (FF) and ◀◀ (REW) buttons.
 - The PHOTO search process appears on the LCD while you are searching.
 - After completing the search, the camcorder displays the still image.
 6. To exit, press the ■ (STOP) button.

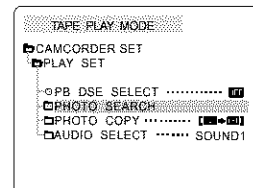
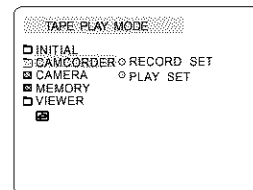

Using the CAMCORDER - Advanced Recording

NITE PIX (0 Lux Recording)

- ❖ The NITE PIX function works in CAMCORDER mode only.
 - ❖ The NITE PIX function enables you to record a subject in darkness.
1. Set the device to CAMCORDER and set the Power Switch to REC mode.
 2. Slide the NITE PIX switch to ON.
 -  (NITE PIX indicator) appears on the LCD monitor.
 - The infrared(invisible rays) light is turned on automatically.
 3. To cancel the NITE PIX function, slide the NITE PIX switch to OFF.

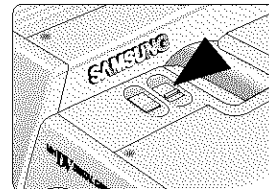

Notes

- The maximum recording distance using the infrared light is about 3 m (about 10 feet).
- If you use the NITE PIX function in normal recording situations (ex. outdoors by day), the recorded picture may be tinted green.
- While in NITE PIX mode, certain functions are not available, such as White Balance, Program AE, DSE, BLC.

Using the CAMCORDER - Advanced Recording

POWER NITE PIX

- ❖ The NITE PIX function works in CAMCORDER mode only.
- ❖ The POWER NITE PIX function can record a subject more brightly in darkness than the NITE PIX function.
- ❖ POWER NITE PIX is displayed for three seconds on the LCD if you press the SLOW SHUTTER button when the NITE PIX switch is turned on.
- ❖ When you work in POWER NITE PIX mode, the POWER NITE PIX icon appears on the LCD continuously.

1. Set the device to CAMCORDER and set the power switch to REC mode.
2. Turn on the NITE PIX switch, and then press the SLOW SHUTTER button.
3. Press the SLOW SHUTTER button to set the shutter speed. The SLOW SHUTTER function enables you to record a subject more brightly.
4. When using POWER NITE PIX the image takes on a slow motion like effect.
5. To cancel the POWER NITE PIX function, press the SLOW SHUTTER button until it is set to " OFF " and then turn off the NITE PIX switch.

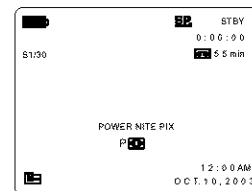
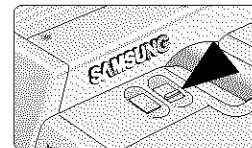

Notes

- The maximum recording distance using the infrared light is about 3 m (about 10 feet).
- If you use the POWER NITE PIX function in normal recording situations (ex. outdoors by day), the recorded picture may contain unnatural colors.
- In POWER NITE PIX mode, certain functions are not available, such as White Balance, Program AE, DSE, BLC.
- When the subject is too bright, it is better to press the SLOW SHUTTER button (S1/8 → S1/30) so that you can record with better quality.

Using the CAMCORDER - Advanced Recording

Various Recording Techniques

❖ In some situations different recording techniques may be required for more dramatic results.

Note

Please rotate the LCD screen carefully as excessive rotation may cause damage to the inside of the hinge that connects the LCD screen to the Camcorder.

1. General Recording.



2. Downward recording.

Recording while viewing the LCD screen from above.

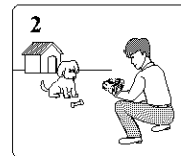

3. Upward Recording.

Recording while viewing the LCD screen from below.

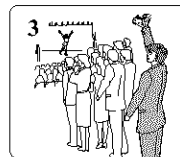

4. Self recording.

Recording while viewing the LCD screen from the front.

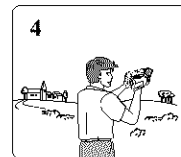

5. Recording with the Viewfinder.

■ In circumstances where it is difficult to use the LCD monitor, the viewfinder can be used as a convenient alternative.



Playback

Tape Playback

- ❖ The playback function works in PLAY mode only.

Playback on the LCD

- ❖ It is practical to view a tape using the LCD when in a car or outdoors.

Playback on a TV Monitor

- ❖ To play back a tape, the television must have a compatible color system.
- ❖ We recommend that you use the AC Power Adapter as the power source for the camcorder.

Connecting to a TV which has Audio/Video Input Jacks

1. Connect the camcorder to the TV with the Audio/Video cable.
 - The Yellow plug : Video
 - The White plug : Audio(L)
 - The Red plug : Audio(R) - STEREO only
 - If you connect to a monaural TV or VCR, connect the Yellow plug (Video) to the video input of the TV or VCR and the White plug (Audio L) to the audio input of the TV or VCR.
2. Set the device to CAMCORDER.
3. Set the power switch to PLAY mode.
4. Turn the TV on and set the TV/VIDEO selector on the TV to VIDEO.
 - Refer to the TV or VCR User's Manual.
5. Play the tape.

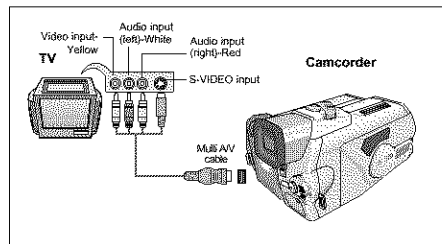

Notes

- You may use a S-VIDEO cable (not supplied) to obtain better quality pictures if you have a S-VIDEO connector on your TV.
- Even if you use a S-VIDEO cable, you need to connect an audio cable.
- If you connect the cable to the A/V Jack, you will not hear sound from the speakers.

Playback

Connecting to a TV which has No Audio and Video Input Jacks

❖ You can connect your camcorder to a TV through a VCR.

1. Connect the camcorder to the VCR with the Audio/Video cable.
 - The Yellow plug : Video
 - The White plug : Audio(L)
 - The Red plug : Audio(R) - STEREO only
2. Connect the TV to the VCR.
3. Set the device to CAMCORDER.
4. Set the power switch to PLAY mode.
5. Turn on both the TV and VCR.
 - Set the input selector on the VCR to LINE.
 - Select the channel reserved for your VCR on the TV set.
6. Play the tape.

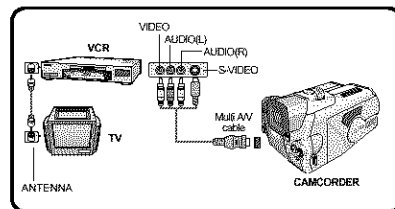

Playback

❖ You can play the recorded tape in PLAY mode.

1. Connect a power source and set the device to CAMCORDER.
2. Set the power switch to PLAY mode.
3. Using the ►► (FF) and ◀◀ (REW) buttons, find the first position you wish to play back.
4. Press the ►|| (PLAY/STILL) button.
 - The images you recorded will appear on the TV after a few seconds.
 - If a tape reaches its end while being played back, the tape will rewind automatically.

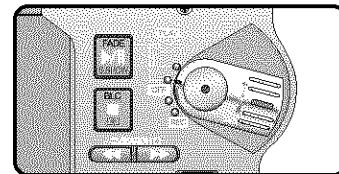

Note

- The playback mode (SP/LP) is selected automatically.

Playback

Various Functions while in *PLAYER Mode*

- ❖ The PLAY/STILL, STOP, FF, REW buttons are located on the camcorder and the Remote Control.
- ❖ The F.ADV(Frame advance), SLOW buttons are located on the Remote Control only.
- ❖ To prevent tape and head-drum wear, your camcorder will automatically stop if it is left in STILL or SLOW modes for more than 5 minutes.

Playback Pause

- ❖ Press the ►/|| (PLAY/STILL) button during Playback.
- ❖ To resume playback, press the ►/|| (PLAY/STILL) button again.

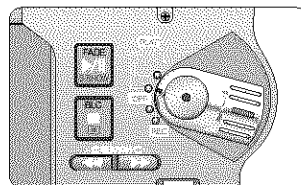

Picture Search - Forward/Reverse

- ❖ Press the ►► (FF) or ◀◀ (REW) buttons once during Playback or while in Still mode. To resume normal playback, press the ►/|| (PLAY/STILL) button.
- ❖ Keep pressing the ►► (FF) or ◀◀ (REW) buttons during Playback or while in Still mode. To resume normal playback, release the button.

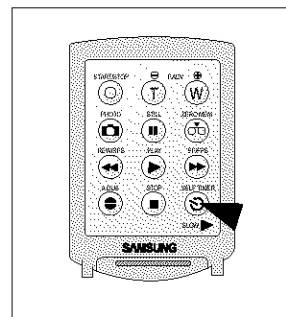

Slow Playback - Forward

- ❖ Forward Slow Playback
 - Press the SLOW button on the remote control during Playback.
 - To resume normal playback, press the ►/|| (PLAY/STILL) button.

Playback

ZERO MEMORY

- ❖ The MEMORY function works in both REC and TAPE PLAY modes.
 - ❖ You can mark a point on a tape that you want to return to following playback.
1. Press the ZERO MEMORY button on the remote control during playback or while recording at the point you wish to return to.
 - The time code is changed to a tape counter that is set to Zero Memory with the **[M]** 0:00:00 (Zero Memory Indicator)
 - If you want to cancel the Zero Memory function, press the ZERO MEMORY button again.
 2. Finding the Zero Position.
 - When you have finished playback, fast forward or rewind the tape.
 - The tape stops automatically when it reaches the Zero Position.
 - When you have finished recording, press the power switch on the PLAYER and press the **◀◀** (REW) button.
 - The tape stops automatically when it reaches the zero position.
 3. The tape counter with the **[M]** (Zero Memory Indicator) disappears from the display and the tape counter is changed back to time code.

Notes

- In the following situations, ZERO MEMORY mode may be canceled automatically:
 - At the end of the section marked with the ZERO MEMORY function.
 - When the tape is ejected.
 - When you remove the battery pack or power supply.
- The Zero Memory may not function correctly when there is a break between recordings on the tape.

IEEE 1394 Data Transfer

Transferring Using IEEE1394 (i.LINK)-DV Standard Data Connections

Connecting to a DV Device

- ❖ Connecting with Other DV Standard Products.
 - A standard DV connection is quite simple.
 - If a product has a DV port(firewire), you can transfer data by connecting to the DV port using the correct cable.
 - !!! Please be careful since there are two types of DV ports, (4pin & 6pin). This camcorder has a 4pin terminal.
- ❖ With a digital connection, video and audio signals are transmitted in digital format, allowing high quality images to be transferred.

Connecting to a PC

- ❖ If you want to transmit data to a PC, you must install an IEEE 1394 add-on card onto the PC. (not supplied)
- ❖ The frame rate recorded for video capturing is dependent on the capacity of the PC.

Notes

- When you transmit data from the camcorder to another DV device, some functions may not work.
 - If this occurs, please reconnect the DV cable or turn the power OFF and ON again.
- When you transmit data from the camcorder to the PC, the PC function button is not available in M.PLAY mode.

IEEE 1394 Data Transfer

● System Requirements

- CPU : Intel®(or compatible) Pentium III™ 450Mhz or faster.
- Operating System : Windows® 98SE, ME, XP, Mac OS (9.1~10.2)
- Main Memory : More than 64 MB RAM
- IEEE1394 Add-On Card or Built In IEEE1394 Card

Recording with a DV Connection Cable

1. Set the device to CAMCORDER and the power switch to TAPE PLAY mode.
 - Make sure that DV IN appears on the screen.
2. Connect the DV cable (not supplied) from the DV IN/OUT port of the camcorder to the DV IN/OUT port of the other DV device.
 - Make sure that DV IN appears on the screen.
3. Press the PLAY button of the CAMCORDER.
 - Picture is displayed on PC screen.
4. Click on the REC button on PC screen with the mouse.
5. To stop recording, click the ■ (STOP) button on the PC screen.

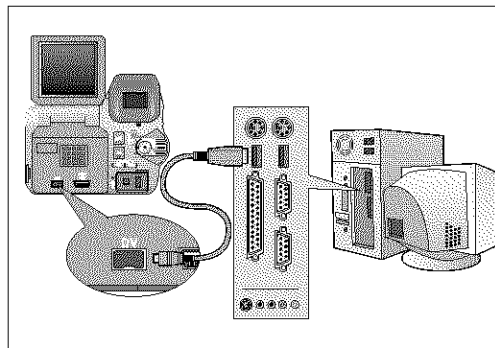

Note

When using this camcorder as a recorder, the pictures that appear on the monitor may seem uneven, however recorded pictures will not be affected.

Using the CAMERA

MEMORY STICK

- ❖ The Memory Stick stores and manages still images recorded by the camera.

Memory Stick Functions

- ❖ Record Still Images
- ❖ View Still Images
 - Single (View Frame by Frame)
 - Slide Show
- ❖ Protect Images Against Accidental Erasure
- ❖ Delete Images Recorded on the Card
- ❖ Add text to Still Images
- ❖ Formatting the Card

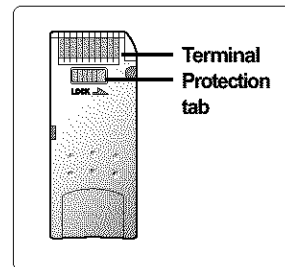

Notes

- You can use most of the camera's functions when recording to the Memory Stick.
- "▶▶▶" appears on the screen while recording to the Memory Stick.
- While recording or loading an image, do not eject or insert the Memory Stick.
 - Inserting or ejecting a Memory Stick while recording or loading an image can cause data damage.
- If you want to save all images on the Memory Stick, set the write protect tab on the Memory Stick to LOCK.



- "Memory Stick" and  are trademarks of Sony Corporation.
- All other product names mentioned herein are the trademarks or registered trademarks of their respective companies. Furthermore, "TM" and "®" will not be mentioned in each case in this manual.
- Memory Sticks of 8MB ~ 128MB are supported.

Using the CAMERA

Inserting and Ejecting the Memory Stick

● Inserting the Memory Stick

1. Turn the Power switch to OFF.
2. Insert the Memory Stick into the CARD slot in the direction of the arrow.

● Ejecting the Memory Stick

1. Turn the Power switch to OFF.
2. Push the Memory Stick, and it will automatically come out of the camcorder.
3. Pull out the Memory Stick.

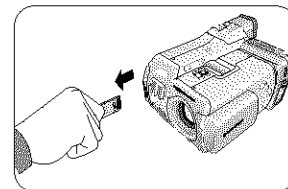
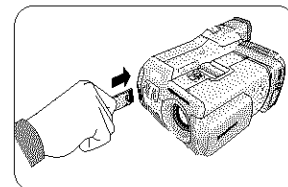

Notes

- If you set the camcorder to MEMORY PLAY mode, the last recorded still image appears.
- If there are no recorded images on the Memory Stick, "NO STORED PHOTO!" will appear on the screen.
- Do not turn the power off while recording, loading, erasing or formatting.
- Please turn the power off before you insert or eject the Memory Stick, otherwise you may lose data on the Memory Stick.
- Do not allow metal substances to come in contact with the terminals of the Card.
- Do not bend the Card.
- After pulling the card out from the camcorder, please keep the Memory Stick in a soft case to prevent electrostatic shock.
- The content stored on the Memory Stick may be changed or lost as a result of misuse, static electricity, electric noise or repair. Save important images separately.
- Samsung is not responsible for data loss due to misuse.

Using the CAMERA

Structure of the Folders and Files on the Memory Stick

- ❖ The still images that you recorded are saved in JPEG file format on the card.
- ❖ Each file has a file number and all files are assigned to a folder.
 - A file number from DCAM0001 to DCAM9999 is sequentially assigned to each recorded image.
 - Each folder is numbered from 100SSDVC to 999SSDVC and recorded on the CARD.

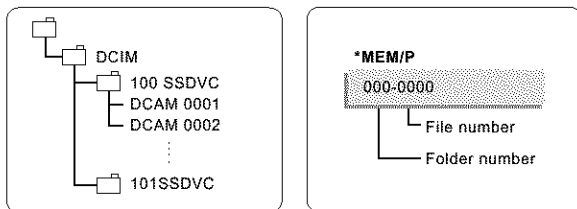

Using the CAMERA

MEMORY FILE NUMBER

- ❖ File numbers will be given to images in order of recording when still images are stored in the Memory Stick.
- ❖ MEMORY FILE NUMBERS may be set as follows:
 - SERIES: When there are existing files, the new image will be named as the next number in the sequence.
 - RESET
 - When there are no files stored in the Memory Stick: The file numbering starts from 0001
 - When there are files stored in the Memory Stick: File numbering will continue after the last file's number

1. Set the device to CAMERA and set the Power Switch to REC mode.
2. Press the MENU button.
 - The menu list will appear.
3. Turn the MENU DIAL to highlight MEMORY and press the MENU DIAL.
4. Turn the MENU DIAL to activate the FILE NO. and press the MENU DIAL.
5. To exit, press the MENU button.

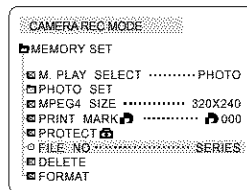
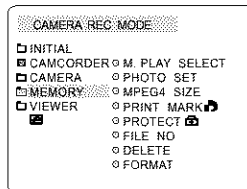

Notes

- When using a Memory Stick that contains image files from another device, the file numbering will begin after the largest number that is memorized whether in the camera or the the Memory Stick.
- File numbering starts from 0001 again when 9999 files have been saved.

Basic Picture-Taking

Taking Your First Picture

1. Connect a power source to the CAMERA (See page 26)
(A battery pack or an AC power adapter)
2. Set the device to CAMERA mode and the power switch to the REC mode.
 - Open the LCD monitor.
 - Ensure that the Memory Stick has been properly inserted into the device.
 - Make sure the image you want to record appears on the LCD monitor or viewfinder.
 - Make sure the battery level indicates that there is enough remaining power for your expected recording time.
3. Press the Photo Button halfway down to set the focus.
 - A Sound Effect will play when the focus is set.
 - Press the Photo Button halfway down to automatically set the focus, White Balance, and exposure for the best results.
4. Press the Photo Button firmly to take a picture.
 - While the camcorder is recording the still image, "▶▶▶" appears on the screen.

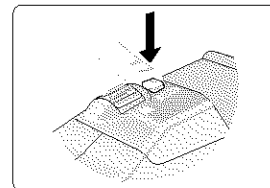
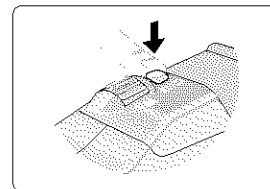
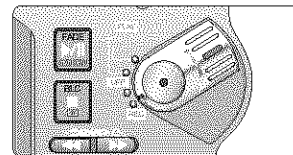

Note

- This Auto Power off feature is designed to save battery power.
- Take a photograph in 2m distance from a photographic subject in low illumination.

Basic Picture-Taking

Viewing Still Images

- ❖ You can playback and view still images recorded on the Memory Stick.
- ❖ Still Images stored on the Memory Stick are displayed in the same size despite their resolution on the LCD or viewfinder.
- ❖ There are 2 ways to view recorded images.
 - Single : To view an image frame by frame.
 - Slide Show : To view all images automatically and in consecutive order.

To View a Single image

1. Set the device to CAMERA.
2. Set the power switch to MEMORY PLAY mode.
 - The last recorded image appears.
 - If there are no recorded images on the Memory Stick, "NO STORED PHOTO!" will appear on the screen.
3. Using the ►►(FWD) and ◄◄(REV) buttons, search for the desired still image.
 - To View the Next Image : press the ►►(FWD) button.
 - To View the Previous Image : press the ◄◄(REV) button.
 - Pressing ►►(FWD) when you are on the last image will take you to the first image and pressing ◄◄(REV) when you are on the first image will take you to the last image.
 - Keep pressing ►►(FWD) or ◄◄(REV) to search for an image quickly.

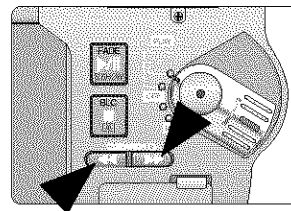
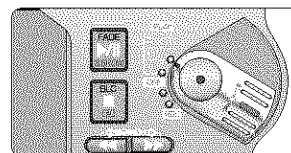

Basic Picture-Taking

To View a Slide Show

1. Set the device to CAMERA
2. Set the power switch to MEMORY PLAY mode.
 - The last recorded image appears.
 - If there are no recorded images on the Memory Stick, "NO STORED PHOTO!" will appear on the screen.
3. Press the **▶/||** (S.SHOW) button.
 - All images will be played back consecutively for 4~5 seconds each.
4. To stop the slide show, press the **▶/||** (S.SHOW) button again.

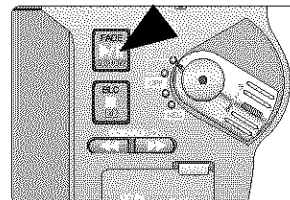
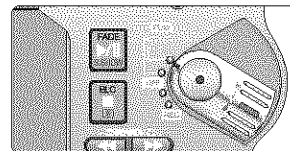

Basic Picture-Taking

Quick Review

❖ Quick Review is used to view the last recorded image.

1. Record a picture using Photo Button.
2. Press the REV(◀◀) Button to view the picture taken.
3. To return to CAMERA mode, press the REV(◀◀) Button again or press the Photo Button halfway down.

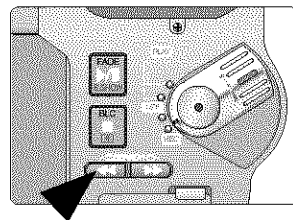
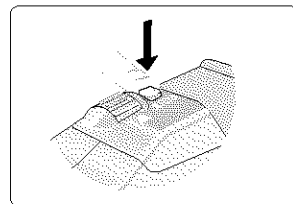

Basic Picture-Taking

Adjusting the Focus

- ❖ In CAMERA Mode, the automatic focus will not engage unless the Photo Button is pressed.
- ❖ To get a good image, please verify the focus is set properly before pressing the Photo Button firmly.
- ❖ While the camera is focusing (by pressing the Photo Button halfway down), a flashing icon () will appear on the OSD (On Screen Display). A beep will be heard once the focus is set.

1. Adjust your frame so that the subject is within the AF frame on the LCD screen.
2. Pressing the Photo Button halfway down will set the focus.
 - When the focus is set, a sound effect will play.
3. Press the Photo Button firmly to take the picture.

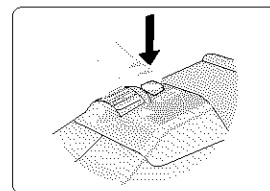
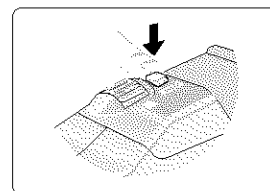
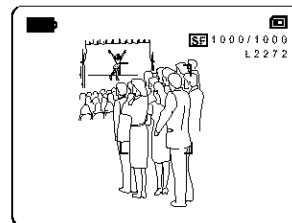

Note

- If the focus is not set properly, release the Photo Button and then press the button halfway down again.
- Use MACRO Mode for recording images at close range (under 30cm), or the proper focus will not occur.
- If the image still seems blurry, use the MF(Manual Focus) feature.

Advanced Techniques

FOCUS LOCK

- ❖ Focus will be set to the AF frame of LCD screen. If the subject leaves the AF frame, the acquired image may blur.
- ❖ When objects are spread throughout the frame, use FOCUS LOCK to get even focusing.

1. First, adjust your frame so that the subject is within the AF frame on the LCD screen.
2. Press the Photo Button halfway down to set the focus on the subject.
3. Adjust your framing with the Photo Button pressed halfway down to get the desired frame.
4. Press the Photo Button fully down to take a picture.

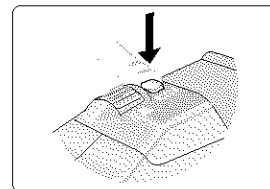
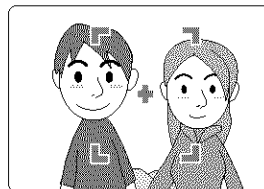
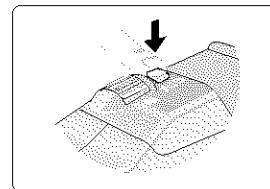
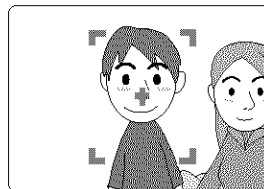

Notes

- To get even focusing, for example, while taking a group photo, maintain a distance of 3~6 m (10~17 ft) when recording.
- The FOCUS LOCK function will not work under 1 m ((3 ft) focal distance).

Advanced Techniques

Digital Zoom in CAMERA Mode

- ❖ A 6X Digital Zoom is provided.
- ❖ The Digital Zoom, which differs from the Optical Zoom, may cause deterioration of image quality. Please use with caution.

1. Set the device to CAMERA and set the power switch to REC mode.
2. Press the MENU button.
 - The menu list will appear.
3. Turn the MENU DIAL to highlight CAMERA and press the MENU DIAL.
4. Turn the MENU DIAL to activate the D. ZOOM and press the MENU DIAL.
 - The D. ZOOM menu is changed to 6X.
 - If you do not want to use the Digital Zoom function, set the D. ZOOM menu to OFF.
5. To exit, press the MENU button.

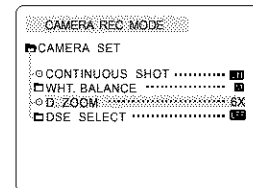
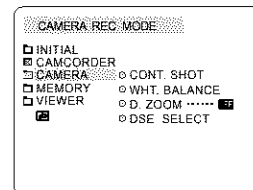

Note

- The Digital Zoom magnifies the image. This may cause deterioration of the image when it is recorded using the maximum rate of magnification.

Advanced Techniques

MACRO Mode

- ❖ The MACRO function works in CAMERA mode only.
- ❖ Use MACRO Mode for recording images at close range (under 31.5 inches).
- ❖ Effective focal distance in MACRO Mode is 11.8 inches ~ 31.5 inches.

Notes

- Pressing the MACRO Button again or turning it off will exit from MACRO Mode.
- Please be careful not to cause a shadow when recording in MACRO Mode.
- As the distance to the subject decreases, focusing area will be narrowed.
- When you can not get proper focus, use the Zoom Lever to achieve focus.
- The viewfinder may not show the entire recording range. Refer to the LCD Screen for more precise framing.

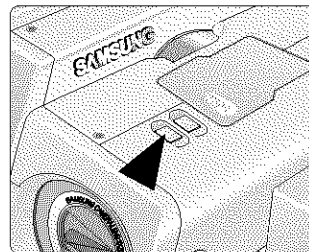

Advanced Techniques

CONT. SHOT (Continuous Shot)

- ❖ The CONT. SHOT function works in CAMERA mode only.
 - ❖ Continuous recording will occur while the Photo Button is being pressed.
 - OFF: Records one picture at a time
 - Records pictures continuously up to storage capacity.
 - When the image resolution is set to 1600 x 1200 or higher, only 3 continuous pictures can be recorded when using CONTINUOUS SHOT.
1. Set the device to CAMERA and set the power switch to REC mode.
 2. Press the MENU button.
 - The menu list will appear.
 3. Turn the MENU DIAL to highlight CAMERA and press the MENU DIAL.
 4. Turn the MENU DIAL to activate CONTINUOUS SHOT and press the MENU DIAL.
 - The CONTINUOUS SHOT menu is changed to ON.
 5. To exit, press the MENU button.

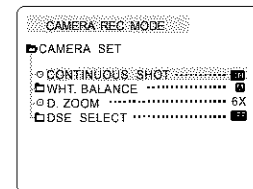
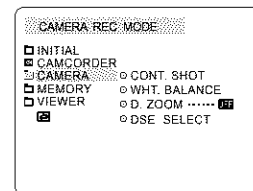

Notes

- When the CONT. SHOT function is set to "ON", an icon is displayed on the LCD screen.
- It is recommended to limit your usage of Continuous Shot to under 10 seconds to prevent problems that may be caused by excessive usage of this feature.
- The flash does not function while using the CONT. SHOT function.

Advanced Techniques

Using the FLASH

- ❖ The FLASH works in CAMERA mode only.
- ❖ When power is supplied, FLASH mode is set to Auto. When you change FLASH modes, an icon that shows the current FLASH mode will be displayed on the LCD screen.
- ❖ Using a flash enables the user to take bright pictures in dark circumstances, such as nighttime shooting and in shaded areas.

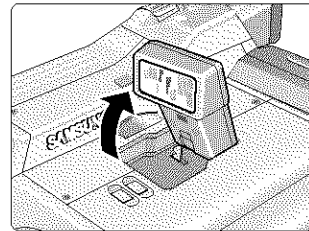

Notes

- By setting the Power Switch to CAMERA Mode after placing the CAMERA side of the Lens Body Block to the forward position, the FLASH will automatically open according to the lighting conditions.
- To close the FLASH, push the FLASH cover until it clicks.
- The Flash does not function in CONTINUOUS SHOT mode or CAMCORDER Mode.
- The battery power will be consumed faster with repeated use of the flash.
- To use the flash again, wait until the flash is recharged (5 to 7 seconds).

Advanced Techniques

FLASH SELECT

- ❖ The FLASH SELECT function works in CAMERA mode only.
 - **Auto** : The Flash automatically strobos when the surroundings are dark enough.
 - **RED-EYE REDUCTION** : Using the flash to take pictures in dark surroundings may cause red-eye to occur. Using the RED-EYE REDUCTION setting, the flash pre-strobes before recording the picture to reduce the occurrence of red-eye .
 - **SLOW SYNC** : When the Shutter Speed is set to SLOW, the flash strobos at the adjusted shutter speed. It is recommended to use a tripod when the shutter speed is set to SLOW.
 - **FILL-IN FLASH** : Forces the flash to strobe despite the light condition. To get finer results, it is recommended to use the flash to take pictures, for example taking a picture of a dark object in the shade of a tree during daylight.
 - **OFF** : Sets the flash not to strobe. It is recommended to set your flash not to strobe in public places like art galleries, museums, and theaters.
1. Set the device to CAMERA and the power switch to REC mode.
 2. Press the PB ZOOM/  button to select flash function.

Advanced Techniques

WHT. BALANCE (WHITE BALANCE) - CAMERA Mode

- ❖ When the recorded color of a subject appears differently because of certain weather or lighting conditions, adjusting the White Balance enables you to get the correct color of the subject.
- ❖ The Adjusted White Balance is stored when the device is turned off. If the battery is fully discharged or detached, the White Balance will return to the AUTO setting, which is the factory default.
 - **AUTO** : This mode is generally used to control the WHITE BALANCE automatically.
 - **HOLD** : This keeps the current WHITE BALANCE value.
 - **INDOOR** : This controls the WHITE BALANCE according to indoor ambience.
 - **OUTDOOR** : This controls the WHITE BALANCE according to outdoor ambience.

1. Set the device to CAMERA and set the power switch to REC mode.
2. Press the MENU button.
 - The menu list will appear.
3. Turn the MENU DIAL to highlight CAMERA and press the MENU DIAL.
4. Turn the MENU DIAL to activate WHT. BALANCE and press the MENU DIAL.
5. Using the MENU DIAL, select the WHT. BALANCE you wish to use.
 - Press the MENU DIAL to confirm the WHT. BALANCE you have selected.
6. To exit, press the MENU button.

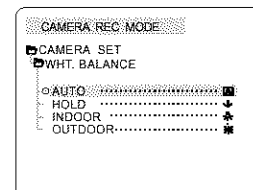
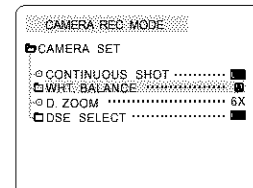
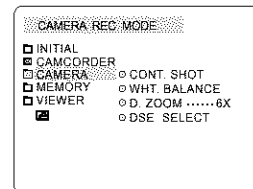

Notes

- The WHT.BALANCE function will not operate in EASY mode.
- Turn the Digital Zoom off (if necessary) to set a more accurate White Balance.
- If you have set the White Balance and the lighting conditions change, reset the White Balance.
- During normal outdoor recording, setting the White Balance to AUTO may provide the best results.

Advanced Techniques

DSE(Digital Special Effects) SELECT in CAMERA Mode

- ❖ The DSE function works in CAMERA mode only.
- ❖ The Digital Effects function will apply special effects to the image while recording.
- ❖ There are 3 DSE (Digital Special Effects) in CAMERA Mode. You can check the DSE applied image on the LCD screen or the viewfinder.

a. BLK & WHT Mode

This mode changes the images to black and white.



b. SEPIA Mode

This mode gives the images a reddish-brown pigment.



c. SUNSET Mode

Sunset Mode is used to record sunsets.

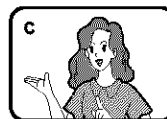

Advanced Techniques

Selecting a Digital Effect in CAMERA Mode

1. Set the device to CAMERA and set the power switch to REC mode.
2. Press the MENU button.
 - The menu list will appear.
3. Turn the MENU DIAL to highlight CAMERA and press the MENU DIAL.
4. Turn the MENU DIAL to activate DSE SELECT and press the MENU DIAL.
5. Using the MENU DIAL, select the DSE you wish to use.
 - Press the MENU DIAL to confirm the DSE you have selected.
6. To exit, press the MENU button.

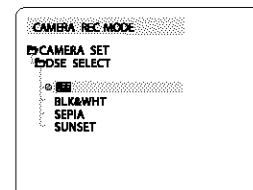
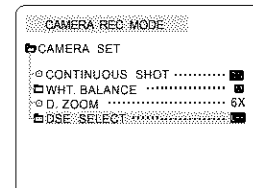
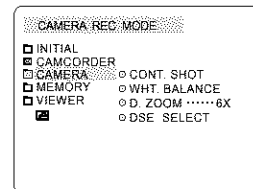

Note

- The DSE function will not operate in EASY mode.

Advanced Techniques

SPOT-AE

- ❖ SPOT AE mode works in CAMERA mode only.
- ❖ Use this function to adjust the exposure of the subject to obtain better results when there is strong backlight or high contrast between the subject and background, for example on seashores or ski slopes.

1. Set the device to CAMERA and the power switch to REC mode.
2. Press the SPOT AE(STOP) button.
 - The Icon() is displayed on the LCD screen.
3. Place the subject in the center of AF frame then press the Photo Button halfway down.
 - After focus is set, you will hear two beeps and an icon that shows focus is fixed will be displayed on the LCD screen
4. Press the Photo Button down fully to record a picture.
5. To exit SPOT AE Mode, press the SPOT AE Button again or turn it off .

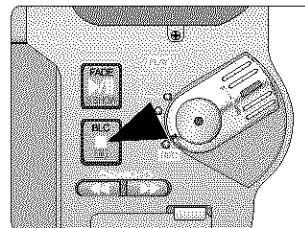

Advanced Techniques

NIGHT SCENE

- ❖ The NIGHT SCENE function works in CAMERA mode only.
 - ❖ The NIGHT SCENE function enables you to record a subject in darkness.
1. Set the device to CAMERA and set the Power Switch to REC mode
 2. Press the NIGHT SCENE button.
 - The (📷) appears on the LCD monitor.
 - The infrared(invisible rays) light is automatically turned on.
 3. To cancel the NIGHT SCENE function, press the NIGHT SCENE button again.

Note

- The maximum recording distance using the infrared light is about 10 ft (about 3m).

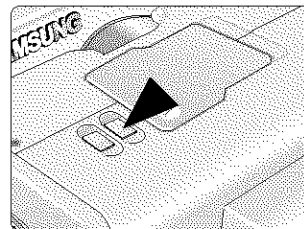

Advanced Techniques

Selecting the Image Quality

- ❖ You can select the quality of a still image to be recorded.

Select the Image Quality

1. Set the device to CAMERA.
2. Set the Power Switch to REC mode.
3. Press the MENU button.
 - The menu list will appear.
4. Turn the MENU DIAL to highlight MEMORY.
5. Press the MENU DIAL to enter the sub-menu.
6. Turn the MENU DIAL to highlight PHOTO SET in the sub-menu.
7. Press the MENU DIAL.
8. Turn the MENU DIAL to highlight QUALITY and press the MENU DIAL.
9. Using the MENU DIAL, select the image quality you wish to use.
 - Press the MENU DIAL to confirm the image quality you have selected.
 - If you exit the sub-menu without pressing the MENU DIAL, the quality mode will not be changed.
10. To exit, press the MENU button.

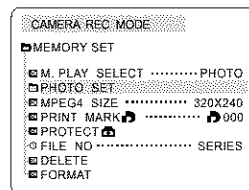
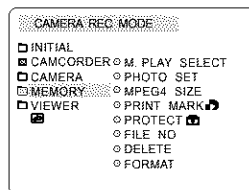

Number of Images on the Memory Stick (L2272)

QUALITY	8MB	16MB	32MB	64MB	128MB
SUPER FINE	Approx.7	Approx.15	Approx.32	Approx.65	Approx.132
FINE	Approx.9	Approx.19	Approx.40	Approx.82	Approx.165
NORMAL	Approx.11	Approx.25	Approx.52	Approx.106	Approx.214

- The actual number that you can record varies depending on the image size.

Advanced Techniques

Selecting the Image Size

- ❖ You can select the size of a still image to be recorded.
- ❖ The number of images that can be stored in the Memory Stick will be decreased as the resolution of images increases.
- ❖ The resolution may be set before recording an image and between recordings. The following 4 modes of resolution are provided:
 - L2272X1704 : Resolution for printing B5 sized images
 - P2272X1504 : Resolution for developing a photograph
 - M1600X1200 : Resolution for printing postcard sized images
 - S640X480 : Resolution for E-mailing Images

Select the Image Size

1. Set the device to CAMERA.
2. Set the Power Switch to REC mode.
3. Press the MENU button.
 - The menu list will appear.
4. Turn the MENU DIAL to highlight MEMORY.
5. Press the MENU DIAL to enter the sub-menu.
6. Turn the MENU DIAL to highlight PHOTO SET in the sub-menu.
7. Press the MENU DIAL.

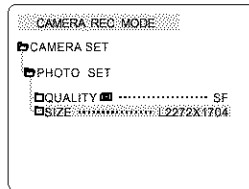
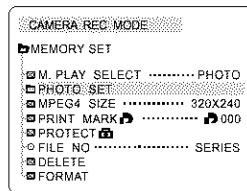
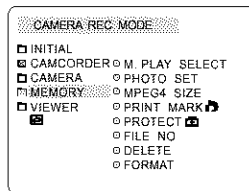

Advanced Techniques

8. Turn the MENU DIAL to highlight SIZE and press the MENU DIAL.
9. Using the MENU DIAL, select the image size.
 - Press the MENU DIAL to confirm the image size.
10. To exit, press the MENU button.

Memory Stick and Image Resolutions (SF mode)

	8MB	16MB	32MB	64MB	128MB
L2272 X 1704	7	15	32	65	132
P2272 X 1504	8	17	38	77	150
M1600 X 1200	14	29	60	123	247
S640 X 480	55	114	234	472	949

Notes

- Estimation is based on image quality being set to FINE mode.
- The number of stored images varies depending on the recording conditions.
- Image resolution is the same what appears on your PC Monitor.
- An Optional Memory Stick is available (up to 128MB).

Advanced Techniques

MPEG REC

❖ This feature enables you to record onto the MEMORY STICK.

1. Check whether the MEMORY STICK has been inserted into the device. If it is not in the device, insert it into the slot.
2. Set the device to CAMCORDER and set the power switch to REC mode.
3. Press the MENU button.
 - The menu list will appear.
4. Turn the MENU DIAL to highlight CAMCORDER and press the MENU DIAL.
5. Select RECORD SET and press the MENU DIAL to enter the sub-menu.
6. Select REC SELECT from the sub-menu and press the MENU DIAL.
 - The REC SELECT toggles between TAPE and MEMORY with each press of the MENU DIAL. Select MEMORY.
7. Press the START/STOP button, The images which are captured are recorded as a moving picture MPEG4 type file onto the MEMORY STICK.(Up to 20 seconds)
 - You can record a camera still image onto the Memory Stick by pressing the Photo button instead the START/STOP button.
8. Press the START/STOP button to stop the recording.

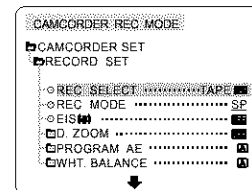
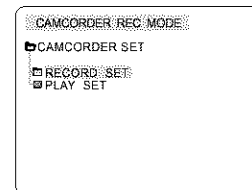
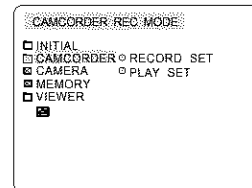

Notes

- Before using the MPEG REC function, check whether the MEMORY STICK has been inserted into the camcorder.
- Moving pictures can be made in two sizes, 160X120 or 320X240 (Pixels).
- Noise can be generated in LCD or Monitor at the time of record.
This noise is not recorded on Memory Stick.

Advanced Techniques

MPEG PB

- ❖ The MPEG PB function works only in MEMORY PLAY mode.
1. Check whether the MEMORY STICK has been inserted into the device. If it is not in the device, insert it into the slot.
 2. Set the device to CAMCORDER and set the Power Switch to MEMORY PLAY mode.
 3. Press the MENU button.
 - The menu list will appear.
 4. Turn the MENU DIAL to highlight MEMORY and press the MENU DIAL.
 5. Select M.PLAY SELECT and press the MENU DIAL.
 - The camera will be set to MPEG Play standby after the MENU screen disappears.
 6. Press the PLAY/STILL button.
 - An MPEG motion clip will be played back.

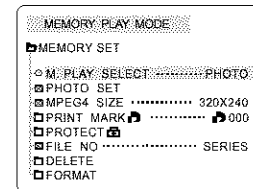
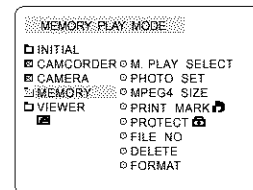

Note

- A MPEG4 reproduction sound can here only PC.

Advanced Techniques

MPEG SIZE

❖ The resolution of the MPEG clip may be set to 320 x 240 or 160 x 120.

1. Check whether the MEMORY STICK has been inserted into the device. If it is not in the device, insert it into the slot.
2. Set the device to CAMCORDER and set the Power Switch to REC mode.
3. Press the MENU button
 - The Menu list will appear.
4. Turn the MENU DIAL to highlight CAMCORDER and press the MENU DIAL.
5. Press the MENU DIAL again.
6. Turn the MENU DIAL to highlight REC SELECT TAPE and press the MENU DIAL.
7. Press the MENU button.
 - The menu list will appear.
8. Turn the MENU DIAL to highlight MEMORY and press the MENU DIAL.
9. Select MPEG SIZE and press the MENU DIAL.
 - The MPEG SIZE toggles between 320X240 and 160X120 with each press of the dial.
10. To exit the menu, press the MENU button.

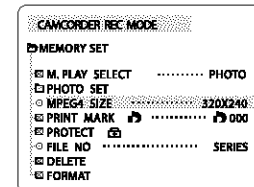
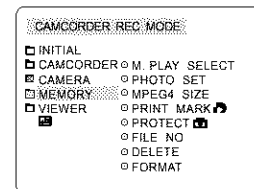

Note

- A higher resolution setting for the MPEG file decreases maximum recording time.

Advanced Techniques

Copying Still Images From a Cassette to the Memory Stick

❖ You can copy still images recorded with the PHOTO function from a cassette to a Memory Stick.

1. Set the device to CAMCORDER and set the Power Switch to TAPE PLAY mode.
2. Press the MENU button.
 - The menu list will appear.
3. Turn the MENU DIAL to highlight PLAY SET and press the MENU DIAL.
4. Select PHOTO COPY and press the MENU DIAL.
 - All still images that have been recorded on the cassette will be copied to the Memory Stick.
5. The camcorder automatically performs the photo search to find still images and copying begins.
6. Press the (STOP) button to stop copying.
 - Copying stops when the cassette is finished or when the Memory Stick is full.

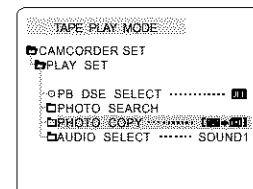
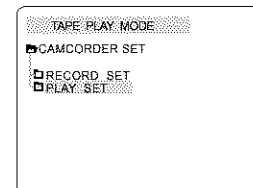
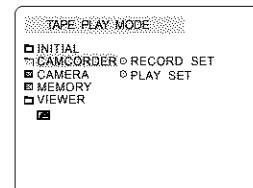

Advanced Techniques

Marking Images for Printing

- ❖ This camcorder supports the DPOF (Digital Print Order Format) print format.
- ❖ You can automatically print images recorded on a Memory Stick with a printer supporting DPOF.
- ❖ There are 2 ways to make a PRINT MARK.
 - THIS FILE : You can set a print mark on the photo image displayed on the LCD.
 - ALL FILES : To print 1 copy each of all of the stored images.

1. Set the device to CAMCORDER and set the Power Switch to MEMORY PLAY mode.
2. Using the ►► (FWD) and ◀◀ (REV) buttons, search for the still image that you want to mark.
3. Press the MENU button.
 - The menu list will appear.
4. Turn the MENU DIAL to highlight MEMORY and press the MENU DIAL.
 - The MEMORY SET sub-menu will appear.
5. Turn the MENU DIAL to highlight PRINT MARK, and press the MENU DIAL.
6. Use the MENU DIAL to select either THIS FILE or ALL FILES and press the MENU DIAL.
7. Use the MENU DIAL to select the quantity and press the MENU DIAL.

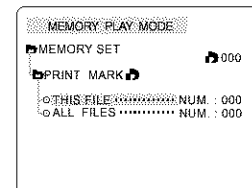
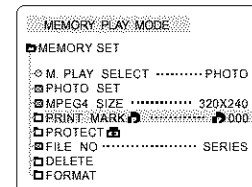
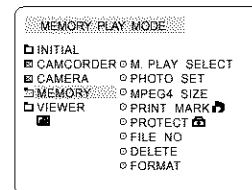

Notes

- When you set the PRINT MARK option to ALL FILES, 999 files from the current file are set to 1 or 0.
- The ALL FILES option may require extended operation time depending on the number of stored images.

Advanced Techniques

Protection from Accidental Erasure

- ❖ You can protect important images from accidental erasure.
 - If you execute FORMAT, all images including protected images will be erased.

1. Set the device to CAMCORDER and set the Power Switch to MEMORY PLAY mode.
2. Using the ►► (FWD) and ◀◀ (REV) buttons, search for the still image that you want to mark.
3. Press the MENU button.
 - The menu list will appear.
4. Turn the MENU DIAL to highlight MEMORY and press the MENU DIAL.
 - The MEMORY SET sub-menu will appear.
5. Turn the MENU DIAL to highlight PROTECT and press the MENU DIAL.
6. Press the MENU DIAL to set PROTECT to ON or OFF.
 - THIS FILE : protects the currently selected file from erasure.
7. Using the ►► (FWD) and ◀◀ (REV), search for the still image that you wish to protect.
8. To exit the menu, press the MENU button.

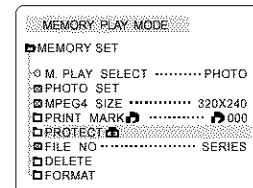
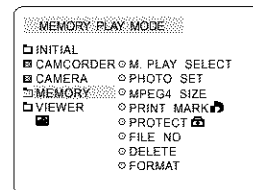

Advanced Techniques

Deleting Still images

- ❖ You can erase the still images recorded on the Memory Stick.
- ❖ If you want to delete protected images, you must first deactivate the image protection.
- ❖ An image which has been deleted cannot be recovered.

1. Set the device to CAMCORDER.
2. Set the Power Switch to the MEMORY PLAY mode.
3. Using the ►► (FWD) and ◀◀ (REV) buttons, search for the still image that you want to delete.
4. Press the MENU button.
5. Turn the MENU DIAL to highlight MEMORY and press the MENU DIAL.
 - The MEMORY SET sub-menu will appear.
6. Turn the MENU DIAL to highlight DELETE and press the MENU DIAL.
7. Select ALL FILES and press the MENU DIAL.
 - Using the MENU DIAL, select either THIS FILE or ALL FILES and press the MENU DIAL.
 - THIS FILE : deletes only the currently selected file.
 - ALL FILES : deletes all files stored in the Memory Stick.

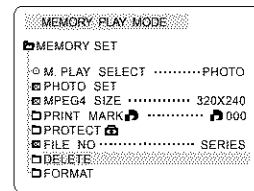
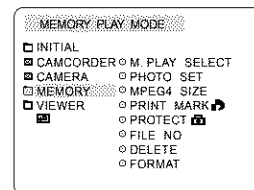

Advanced Techniques

8. A box will appear to verify whether you wish to delete the image(s).
- Using the MENU DIAL, select the item.
 - EXECUTE : Deletes the selected image(s).
 - CANCEL : Does not delete the selected image(s) and returns to the previous menu.
9. Select EXECUTE or CANCEL and press the MENU DIAL.

Note

- If you try to delete a protected image, "PROTECT!" appears on the screen.

Advanced Techniques

Formatting the Memory Stick

- ❖ You can use the MEMORY FORMAT functions to completely delete all images and options on the Memory Stick, including protected images.
- ❖ The format function restores the Memory Stick to its initial state.
- ❖ The Memory Stick supplied with this camcorder has already been formatted.

Attention

- ❖ If you execute the MEMORY FORMAT function, all images will be erased completely and cannot be recovered.

1. Set the device to CAMCORDER and set the Power Switch to the MEMORY PLAY mode.
2. Press the MENU button.
3. Turn the MENU DIAL to highlight MEMORY and press the MENU DIAL.
4. Select FORMAT from the list and press the MENU DIAL.
5. "ALL FILES ARE DELETED! FORMAT REALLY?" appears on the screen.
6. Using the MENU DIAL, select the item.
 - NO : To return to previous menu
 - YES : To start formatting.
7. Press the MENU DIAL.
8. To exit the menu, press the MENU button.

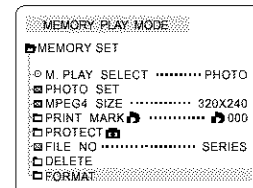
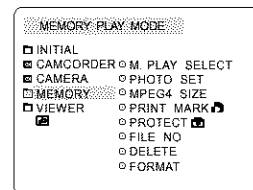

Note

- If you want to format the Memory Stick on your PC, use the "Memory Stick Formatter" supplied with the software CD only.

Advanced Techniques

Recording an Image from a Cassette as a Still Image.

- ❖ You can record a still image from a cassette onto a Memory Stick.
 - ❖ If you want to record multiple still images from a cassette to a Memory Stick, use the COPY function.
1. Set the device to CAMCORDER and the Power Switch to REC mode.
 2. Press the MENU DIAL.
 3. Turn the MENU DIAL to highlight CAMCORDER and press the MENU DIAL.
 4. Select RECORD SET and press the MENU DIAL.
 5. Turn the MENU DIAL to highlight REC SELECT and press the MENU DIAL.
 - Set REC SELECT to MEMORY. By pressing the MENU DIAL you can toggle between TAPE and MEMORY modes.
 6. To exit the menu, press the MENU button.
 7. Press the Photo button.
 - The still image is recorded onto the Memory Stick.
 - While the camcorder is recording the still image, "▶▶▶" appears on the screen.

USB Interface

● Transferring a Digital Image through a USB Connection

- ❖ You can easily transfer a still image from a MEMORY STICK to a PC without additional add-on cards via a USB connection.
- ❖ You can transfer an image to a PC via a USB connection.
- ❖ If you transfer data to a PC, you need to install the software (Driver, Editing software) supplied with the camcorder.

System Requirements

- CPU : Intel® Pentium(or compatible) II™ 400 processor faster
- Operating system : Windows® 98SE/ME/2000/XP
- RAM : 64 MB or more
- CD-ROM: 4x CD-ROM drive
- VIDEO : 65,000-Color or better video display card
- Available USB Port
- Hard Disc : 4GB (8GB recommended)

Notes

- Intel® Pentium II™ is a trademark of the Intel Corporation.
- Windows® is a registered trademark of the Microsoft® Corporation.
- All other brands and names are the property of their respective owners.

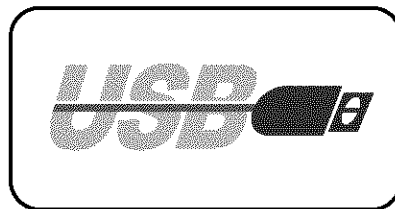

USB Interface

Installing the DVC Media 5.0 Program

- ❖ Do not connect the camcorder to PC before installing the program.
- ❖ If another camera or scanner is connected, please disconnect it in advance.
- ❖ This explanation is based on Windows® 98SE OS.

Program installation

1. Insert the software CD into CD-ROM drive.
 - Installation selection screen appears in the monitor.
2. If the installation selection screen does not appear after inserting the CD click "Run" on the Windows "Start" menu and execute SETUP.EXE file to begin installation.
 - When CD-ROM drive is set to "D:drive", type "D:\setup.exe" and press Enter.
3. Click one of the icons listed below to install the selected software. (The program automatically check and install the driver which the PC is needed)
 - DVC Driver: USB removable Disk Driver (Windows® 98SE only)
USB PC CAMERA Driver
 - Editing Software

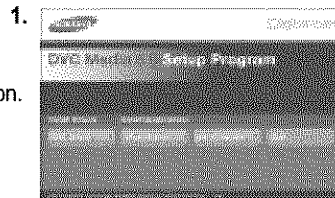

Using the "removable Disk" function

- ❖ You can easily transfer data from a memory stick to a PC without additional add-on cards via a USB connection.
1. Set the device to CAMERA and set the power switch to REC or M.PLAY mode.
 2. Connect one end of the USB cable to the USB jack on the camcorder and the other end to the USB connector on your computer.

Using the "PC camera" function

- ❖ You can use this camcorder as a PC CAMERA.
 - ❖ When you connect to a Web site that can provide video chatting functions, you can use your camcorder for such functions.
 - ❖ Using the camcorder with PC installed Net-meeting program, you can conduct video conference.
 - ❖ The screen size of PC CAMERA is 160 X 120 Pixel.
 - ❖ If PC is connected with the USB to the camcorder, the buttons which excepts the POWER SWITCH, MODE SWITCH, ZOOM SWITCH, and NITE PIX SWITCH are not operated.
1. Set the device to CAMCORDER and set the power switch to REC mode.
 2. Connect one end of the USB cable to the USB jack on the camcorder and the other end to the USB connector on your computer.

USB Interface

Connecting to a PC

1. Connect a USB cable to the USB port on the PC.
2. Connect the other end of the USB cable into the proper terminal on the camcorder. (USB jack)

Disconnecting the USB cable

❖ After completing the data transmission, you must disconnect the cable in the following way:

1. Select the removable disc icon and click the right mouse button to select [Eject].
2. Select [Confirm] and disconnect the USB cable when the Windows Splash screen appears.

Notes

- If you disconnect the USB cable from the PC or the camcorder while transferring, the data transmission will stop and the data may be damaged.
- If you connect the USB cable to a PC via a USB HUB or simultaneously connect the USB cable along with other USB devices, the camcorder may not work properly.
 - If this occurs, remove all USB devices from the PC and reconnect the camcorder.

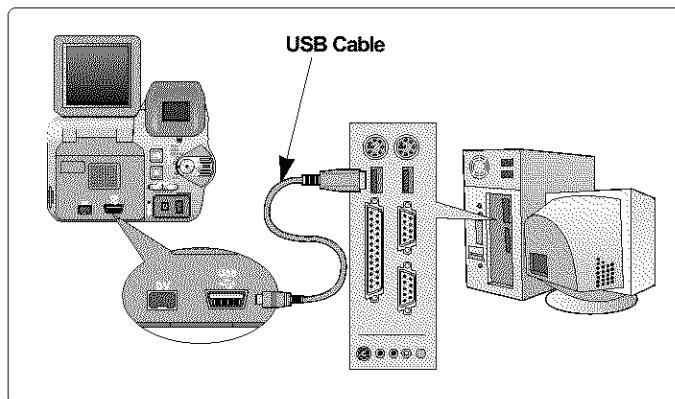

Maintenance

After Finishing a Recording

- ❖ At the end of a recording you should remove the power source.
 - ❖ When recording with a Lithium Ion Battery Pack, leaving the pack on the camcorder can reduce the life span of the battery. Therefore, it should be removed from the camcorder.
1. Slide the TAPE OPEN/EJECT switch in the direction of the arrow.
 - Opening the cassette door ejects the tape automatically.
 - Please wait for the tape to be completely ejected.
 2. After removing the tape, close the door and store the camcorder in a dust free environment.
 - Dust and other foreign materials can cause square-shaped noise or jerky images.
 3. Set the power switch to OFF.
 4. Disconnect the power source or remove the Lithium Ion Battery Pack.
 - Hold down the BATTERY RELEASE button and slide the battery pack in the direction of the arrow.

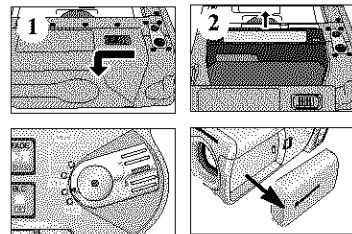

Maintenance

Cleaning and Maintaining the Camcorder

Cleaning the Video Heads

To ensure normal recording and clear pictures, clean the video heads when the playback pictures display square block-shaped noise or distortion or a blue screen appears.

1. Set the device to CAMCORDER.
2. Insert the Cleaning Tape.
3. Press the ►/II (PLAY/STILL) button.
4. Press the ■ (STOP) button after 10 seconds.

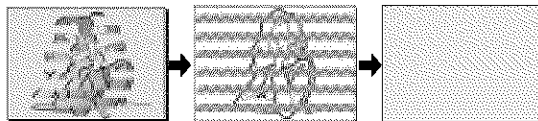

Notes

- Check the quality of the picture using a videocassette.
If the picture quality has not improved, repeat the operation.
If the problem continues, contact your local authorized service center.
- Clean the video heads with a dry-type cassette cleaner.

Maintenance

Using Your Camcorder Abroad

- ❖ Each country or region has its own electric and color systems.
- ❖ Before using your camcorder abroad, check the following items.

Power Sources

- You can use your camcorder in any country or area with the supplied AC Power Adapter within 100V to 240V, 50/60 Hz.
- Use a commercially available AC plug Adapter, if necessary, depending on the design of the local wall outlet.

Color System

- You can view your recording in the viewfinder.
However, to view it on a television or copy it to a videocassette recorder, the television or VCR must be NTSC-compatible and have the appropriate audio/video jacks.
Otherwise, you may need to use a transcoder.

● PAL-Compatible Countries/Regions

Australia, Austria, Belgium, Bulgaria, China, CIS, Czech Republic, Denmark, Egypt, Finland, France, Germany, Greece, Great Britain, Holland, Hong Kong, Hungary, India, Iran, Iraq, Kuwait, Libya, Malaysia, Mauritius, Norway, Romania, Saudi Arabia, Singapore, Slovak Republic, Spain, Sweden, Switzerland, Syria, Thailand, Tunisia, etc.

● NTSC-compatible Countries/Regions

Bahamas, Canada, Central America, Japan, Mexico, Philippines, Korea, Taiwan, United States of America, etc.

Note



You can make recordings with your camcorder and view pictures on the LCD from anywhere in the world.

Troubleshooting

Troubleshooting

- ❖ Before contacting a Samsung authorized service center, perform the following simple checks. They may save you the time and expense of an unnecessary call.

Self Diagnosis Display

Display	Blinking	Informs that...	Action
	slow	the battery pack is almost discharged.	Change to a charged one.
TAPE END!	slow	When the remaining time on the tape is about 2 minutes	Prepare a new one.
TAPE END!	no	the tape reached its end.	Change to a new one.
TAPE!	slow	there is no tape in camcorder.	Insert a tape.
PROTECTION!	slow	the tape is record protected.	If you want to record, release the protection.
	slow	the camcorder has some mechanical fault.	<ol style="list-style-type: none"> 1. Eject the tape. 2. Set to OFF. 3. Detach the battery. 4. Reattach the battery. * If unresolved contact your local service representative.
	slow	moisture condensation has formed in the camcorder.	see below.

Moisture Condensation

- ❖ If the camcorder is brought directly from a cold place to a warm place, moisture may condense inside the camcorder, on the surface of the tape, or on the lens. In this condition, the tape may stick to the head drum and be damaged or the unit may not operate correctly.
To prevent possible damage under these circumstances, the camcorder is fitted with a moisture sensor.
- ❖ If there is moisture inside the camcorder,  (DEW) is displayed. If this happens, none of the functions except cassette ejection will work.
Open the cassette compartment and remove the battery.
Leave the camcorder for at least two hours in a dry warm room.

Troubleshooting

Self Diagnosis Display in M.REC/M.PLAY Mode

Display	Blinking	Informs that...	Action
MEMORY STICK!	slow	There no Memory stick in the camcorder.	Insert a Memory Stick.
MEMORY FULL!	slow	There is not enough memory to record.	Change to a new Memory Stick. Erase recorded image.
NO STORED PHOTO!	slow	There are no images recorded on the Memory Stick.	Record new images.
WRITE PROTECT!	slow	The Memory Stick is record protected.	Release the write protect tab on the Memory Stick.
PROTECT!	slow	When you try to delete to protected image.	Cancel the protect of image.
READ ERROR!	slow	The camera can not playback.	Format a Memory Stick or insert Memory Stick recorded on this camcorder.
WRITE ERROR!	slow	The camera can not record.	Format a Memory Stick or change to a new Memory Stick.
NOT FORMATTED!	slow	The card or memory needs to format.	Format a Memory Stick.
NOW DELETE...	slow	When progressing FILE DELETE.	Wait until Delete has finished.
NOW FORMAT...	slow	When progressing MEMORY FORMAT.	Wait formatting has finished.
NOW COPY...	slow	When progressing FILE COPY.	Wait until copying has finished.

Troubleshooting

- ❖ If these instructions do not solve your problem, contact your nearest Samsung authorized service center.

Symptom	Explanation/Solution
You cannot switch the camcorder on.	Check the battery pack or the AC Power Adapter.
START/STOP button does not operate while recording.	Check the POWER switch is set to CAMERA. You have reached the end of the cassette. Check the record protection tab on the cassette.
The camcorder goes off automatically.	You have left the camcorder set to STBY for more than 5 minutes without using it. The battery pack is fully exhausted.
The battery pack is quickly exhausted.	The atmospheric temperature is too low. The battery pack has not been charged fully. The battery pack is completely dead, and cannot be recharged. Use another battery pack.
When you see a blue screen during playback.	The video heads may be dirty. Clean the head with a cleaning tape.
A vertical strip appears on the screen when recording a dark background.	The contrast between the subject and the background is too great for the camcorder to operate normally. Make the background bright to reduce the contrast or use the BLC function while you are recording brighter.
The image in the viewfinder is blurred.	The Viewfinder lens has not been adjusted. Adjust the viewfinder control lever until the indicators displayed on the viewfinder come into sharp focus.
Auto focus does not work.	Check the M.FOCUS menu. Auto focus does not work in the Manual Focus mode.
Play, FF or REW button does not work.	Check the POWER switch. Set the power switch to PLAYER. You have reached the beginning or end of the cassette.
When you see a broken block image during the RECORD SEARCH.	This is normal operation and it is not a failure or defect.

Specifications

Model name: SCD5000

System	
Video signal	NTSC
Video recording system	2 rotary heads, Helical scanning system
Audio recording system	Rotary heads, PCM system
Usable cassette	Digital video tape (6.35mm width): Mini DV cassette
Tape speed	SP: approx. 18.81mm/s LP: approx. 12.56mm/s
Tape recording time	SP: 60 minutes (when using DVM 60), LP: 90 minutes (when using DVM 60)
FF/REW time	Approx. 180 sec. (using DVM60 tape)
Image device	CCD (Charge Coupled Device), 413M CCD (DIGITAL CAMERA)
Lens	F1.4 10x(Optical), 800x(Digital) Electronic zoom lens (CAMCORDER CAMERA), F2.7 3x(Optical), 6x(Digital) Electronic zoom lens (DIGITAL CAMERA)
Filter diameter	Ø30
LCD monitor/Viewfinder	
Size/dot number	2.0 inches (211,000)
LCD monitor Method	TFT LCD
Viewfinder	0.24" Color LCD
Connectors	
Video output	1Vp-p (75Ω terminated)
S-video output	Y: 1Vp-p, 75Ω, C: 0.286Vp-p, 75Ω
Audio output	-7.5dBs (600Ω terminated)
DV input/output	4pin special in/out connector
USB output	Mini-B type connector
External mic	Ø3.5 stereo
General	
Power source	DC 8.4V, Lithium Ion Battery Pack 7.4V
Power source type	Lithium Ion Battery Pack, Power supply (100V~240V) 50/60Hz
Power consumption (Recording)	4.9W(LCD), 4.6W(CVF)
Operating temperature	0°~40°C (32°F~104°F)
Storage temperature	-20°C ~ 60°C (-4°F ~ 140°F)
External dimension	Length 140mm, Height 82mm, Width 95mm
Weight	1.21lbs(650g)
Built-in MIC	Omni-directional stereo condenser microphone
Remote control	Indoors: greater than 15m straight line, Outdoors: greater than 5m straight line

- These technical specifications and design may be changed without notice.

INDEX

- A -

Audio dubbing 71
 AUDIO MODE 63

- B -

BLC 69

- C -

CAMCORDER mode 50
 Cassette 49
 Cleaning and Maintaining the Camcorder 120
 CLOCK SET 41
 CONT. SHOT 95

- D -

DATE/TIME 44
 DELETE 112
 DEMONSTRATION 43
 DIGITAL ZOOM 48
 DSE 60, 99

- E -

EASY Mode 46
 EIS 59

- F -

Fade In and Out 70
 Features 14
 FILE NUMBER 86
 FLASH 96
 Focus 91
 folders and files 85
 FORMAT 114

- H -

Hand Strap 25

- I -

IEEE1394 81
 image quality 103
 image size 104

- L -

LCD 32
 Lithium battery 13

- M -

MACRO 94
 MEMORY STICK 83
 MENU 35
 MF/AF 47
 MPEG PB 107
 MPEG REC 106
 MPEG SIZE 108

- N -

NITE PIX 74
 NIGHT SCENE 102

- O -

OSD 21

- P -

PHOTO 73
 Playback 77
 POWER NITE PIX 75
 Power Source 26
 Power Switch 31
 PRINT MARK 110
 PROGRAM AE 55
 PROTECT 111

INDEX

- Q -		- U -	
Quick Menu	65	USB	116
Quick Review	90	- V -	
- R -		VIEWFINDER	33
REC MODE	62	Viewing Still images	88
Remote Control	24	- W -	
- S -		WHT. BALANCE	57, 98
Search	52	WIND CUT	64
SHUTTER SPEED & EXPOSURE	67	WL.REMOTE	42
slide show	89	- Z -	
SLOW SHUTTER	68	ZERO MEMORY	80
Speaker	34		
SPOT-AE	101		
- T -			
Troubleshooting	122		
TV DISPLAY	45		

Warranty

SAMSUNG LIMITED WARRANTY

SAMSUNG Electronics America Inc. (SEA), warrants that this product is free from defective material and workmanship. SEA further warrants that if product fails to operate properly within the specified warranty period and the failure is due to improper workmanship or defective material, SEA will repair or replace the product at it's option.

All warranty repairs must be performed by a SEA authorized service center. The name and address of the location nearest you can be obtained by calling toll free: 1-800 SAMSUNG (1-800-726-7864).

Labor

90 days carry-in

Parts

1 year

On carry-in models, transportation to and from the service center is the customer's responsibility.

The original dated sales receipt must be retained by the customer and is the only acceptable proof of purchase. It must be presented to the authorized service center.

EXCLUSIONS (WHAT IS NOT COVERED)

This warranty does not cover damage due to accident, fire, flood and/or other acts of God; misuse, incorrect line voltage, improper installation, improper or unauthorized repairs, commercial use, or damage that occurs in shipping. Exterior and interior finish, lamps, and glass are not covered under this warranty.

Customer adjustments which are explained in the instruction manual are not covered under the terms of this warranty. This warranty will automatically be voided for any unit found with a missing or altered serial number. This warranty is valid only on products purchased in the United States and Puerto Rico.

Some States do not allow the exclusions or limitations of incidental or consequential damages, or allow limitations on how long an implied warranty lasts, so the above limitations or exclusions may not apply to you. This warranty gives you specific legal rights, and you may also have other rights which vary from State to State.

ENGLISH

THIS CAMCORDER IS MANUFACTURED BY:



SERVICE DIVISION
400 Valley Road, Suite 201, Mt. Arlington N.J. 07856
Tel: 1-800-SAMSUNG
(1-800-726-7864)

***Samsung Electronics' Internet Home Page**
<http://www.samsungusa.com>

AD68-00655B(01)