

Micro Hi-Fi Component System

Operating Instructions

Owner's Record

The model and serial numbers are located on the bottom of the unit. Record the serial number in the space provided below. Refer to them whenever you call upon your Sony dealer regarding this product.

Model No. _____ Serial No. _____



CMT-EP707

WARNING

To prevent fire or shock hazard, do not expose the unit to rain or moisture.

To avoid electrical shock, do not open the cabinet. Refer servicing to qualified personnel only.

Do not install the appliance in a confined space, such as a bookcase or built-in cabinet.

CLASS 1 LASER PRODUCT
LUOKAN 1 LASERLAITE
KLASS 1 LASERAPPARAT

This appliance is classified as a CLASS 1 LASER product.

This label is located on the bottom.

To prevent fire, do not cover the ventilation of the apparatus with newspapers, table-cloths, curtains, etc. And don't place lighted candles on the apparatus.

To prevent fire or shock hazard, do not place objects filled with liquids, such as vases, on the apparatus.



Don't throw away the battery with general house waste, dispose of it correctly as chemical waste.

NOTICE FOR THE CUSTOMERS IN THE U.S.A.

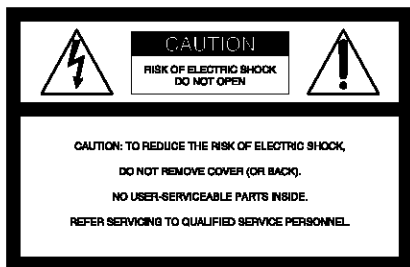

This symbol is intended to alert the user to the presence of uninsulated "dangerous voltage" within the product's enclosure that may be of sufficient magnitude to constitute a risk of electric shock to persons.



This symbol is intended to alert the user to the presence of important operating and maintenance (servicing) instructions in the literature accompanying the appliance.

CAUTION

The use of optical instruments with this product will increase eye hazard.

WARNING

This equipment has been tested and found to comply with the limits for a Class B digital device, pursuant to Part 15 of the FCC Rules. These limits are designed to provide reasonable protection against harmful interference in a residential installation. This equipment generates, uses, and can radiate radio frequency energy and, if not installed and used in accordance with the instructions, may cause harmful interference to radio communications. However, there is no guarantee that interference will not occur in a particular installation. If this equipment does cause harmful interference to radio or television reception, which can be determined by turning the equipment off and on, the user is encouraged to try to correct the interference by one or more of the following measures:

- Reorient or relocate the receiving antenna.
- Increase the separation between the equipment and receiver.
- Connect the equipment into an outlet on a circuit different from that to which the receiver is connected.
- Consult the dealer or an experienced radio/TV technician for help.

CAUTION

You are cautioned that any changes or modifications not expressly approved in this manual could void your authority to operate this equipment.

Note to CATV system installer:

This reminder is provided to call the CATV system installer's attention to Article 820-40 of the NEC that provides guidelines for proper grounding and, in particular, specifies that the cable ground shall be connected to the grounding system of the building, as close to the point of cable entry as practical.

Except for European model:



ENERGY STAR® is a U.S. registered mark.

As an ENERGY STAR® partner, Sony Corporation has determined that this product meets the ENERGY STAR® guidelines for energy efficiency.

NOTICE FOR THE CUSTOMERS IN CANADA

CAUTION

TO PREVENT ELECTRIC SHOCK, DO NOT USE THIS POLARIZED AC PLUG WITH AN EXTENSION CORD, RECEPTACLE OR OTHER OUTLET UNLESS THE BLADES CAN BE FULLY INSERTED TO PREVENT BLADE EXPOSURE.

Table of Contents

List of Button Locations and Reference Pages

Main unit	4
Remote control	5

Getting Started

Hooking up the system	6
Inserting two size AA (R6) batteries into the remote	7
Setting the clock	7

CD

Loading the CD	8
Playing the CD	
— Normal Play/Shuffle Play/Repeat Play	8
Programming the CD tracks	
— Program Play	9

Tuner

Presetting radio stations	10
Listening to the radio	
— Preset Tuning	11
— Manual Tuning	11
Using the Radio Data System (RDS)*	11

Tape

Loading a tape	13
Playing a tape	13
Recording to a tape	
— CD Synchro Recording/Recording Manually	14
— Program Edit	15
Timer-recording radio programs	15

Sound Adjustment

Adjusting the sound	
— MEGA BASS	16
Turning off the sound	
— Muting	16

Timer

Falling asleep to music	
— Sleep Timer	16
Waking up to music	
— Daily Timer	16

Display

Turning off the display	
— Power Saving Mode	17
Using the CD display	17

Optional Components

Hooking up optional components	18
Listening to audio from a connected component	18
Recording a CD on a connected digital component	18
Recording audio from a connected component	18

Troubleshooting

Problems and remedies	19
-----------------------------	----

Additional information

Precautions	21
Specifications	22

* For European model only

How to use this page

Use this page to find the location of buttons and other parts of the system that are mentioned in the text.

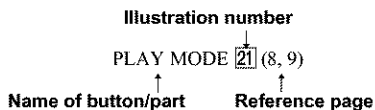

Main unit

ALPHABETICAL ORDER

A - M

- Cassette compartment **5** (13)
- CD **3** (8, 9)
- DISC 1/DISC 2/DISC 3 **14** (8, 9, 14)
- Disc tray **15** (8)
- DISC SKIP **3** (8)
- DISPLAY **22** (12, 17)
- Display Window **4** (8, 9, 10)
- ENTER **1** (7, 9, 10, 15, 16, 17)
- FM MODE/DIR **21** (11, 13, 14, 15, 20)
- MD **7** (14, 18)
- MEGA BASS **18** (16)
- MUSIC MENU **17** (16)

P - Z

- PGM CLEAR **8** (9)
- PHONES jack **19**
- PLAY MODE **21** (8, 9)
- PRESET +/- **13** (10, 11)
- Remote sensor **23**
- TAPE **2** (13)
- TUNER **6** (10, 11, 14)
- TUNER MEM **10** (10)
- TUNING +/- **12** (10, 11)
- VOLUME control **16**

BUTTON DESCRIPTIONS

⏻ (power) **20** (7, 15, 17)

CD

- ⏮** (go back) **12** (8, 9)
- ⏭** (go forward) **12** (8, 9)
- ▶** (play) **1** (8, 9)
- ⏸** (pause) **10** (8)
- ⏏** (eject) **14** (8)
- (stop) **8** (8)

TAPE

- ⏭** (fast forward) **12** (13)
- ⏸** (pause) **10** (13)
- ▶** (play) **1** (13, 14)
- REC PAUSE/START **11** (14, 15)
- ⏮** (rewind) **12** (13)
- ⏏** PUSH OPEN/CLOSE **9** (13)
- (stop) **8** (13, 14)

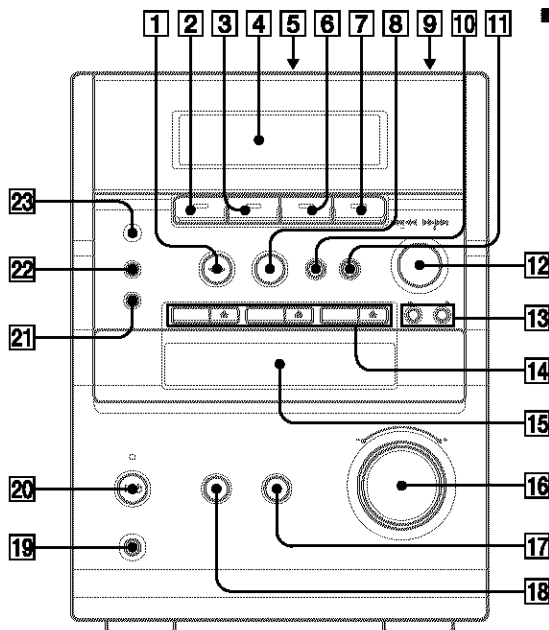

Remote control

ALPHABETICAL ORDER

A - M

- CD **11** (8, 9)
- CLOCK/TIMER ON/OFF **2** (15, 17)
- CLOCK/TIMER SET **3** (7, 15, 16)
- DISC SKIP **7** (8)
- DISPLAY **6** (12, 17, 19)
- ENTER **16** (7, 9, 10, 15, 16, 17)
- FM MODE **8** (11, 20)
- MD **9** (14, 18)
- MEGA BASS **14** (16)
- MUSIC MENU +/- **17** (16)
- MUTING **18** (16)

P - Z

- PGM CLEAR **12** (9)
- PLAY MODE **20** (8, 9)
- PRESET/CLOCK/TIMER +/- **23** (10, 11, 15, 17)
- REPEAT/DIR **21** (8, 13, 14, 15)
- SLEEP **1** (16)
- TAPE **19** (13)
- TUNER/BAND **10** (10, 11, 14)
- TUNER MEMORY **18** (10)
- TUNING +/- **22** (10, 11)
- VOL (volume) +/- **13**

BUTTON DESCRIPTIONS

- 1** (power) **4** (7, 15, 17)
- ◀** (rewind) **▶** (fast forward) **22** (8, 13)
- ◀◀** (go back) **▶▶** (go forward) **23** (7, 8, 9, 13)
- ||** (pause) **24** (8, 13)
- ▶** (play) **25** (8, 9, 13, 14)
- (stop) **5** (8, 13, 14)

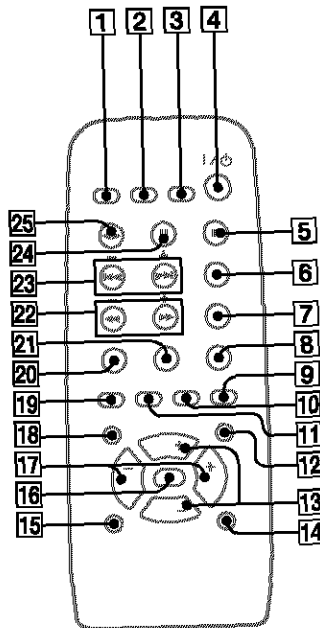

Hooking up the system

Do the following procedure **1** to **4** to hook up your system using the supplied cords and accessories.

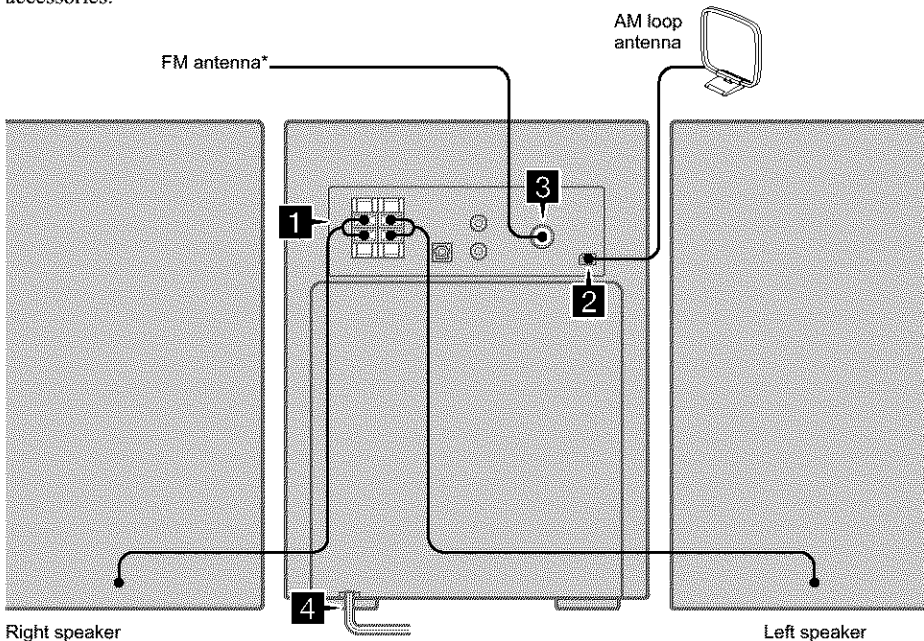

* Except for European model

1 Connect the speakers.

Connect the speaker cords to the SPEAKER terminals as shown below.

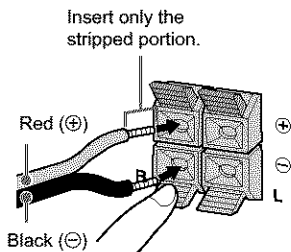

2 Connect the AM antenna.

Set up the AM loop antenna, then connect it.

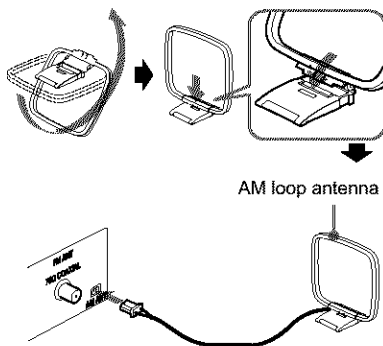

- 3** Connect the FM antenna (except for European model).

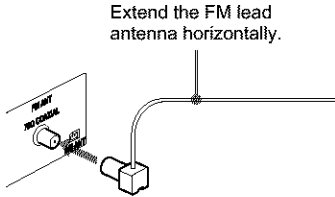

- 4** Connect the power cord to a wall outlet.

If the supplied adaptor on the plug does not fit your wall outlet, detach it from the plug (only for models equipped with the adaptor).

To turn on the system, press **⏻** / **⏻** (power).

Note

When carrying this system, make sure that all discs are removed from the system.

When carrying this system

Perform the following procedure to protect the CD mechanism.

- 1 Make sure that the disc is removed from the system.
- 2 Re-tie the strip that was attached to the CD tray when you purchased the system.
- 3 Press **⏻** / **⏻** to turn off the system.
- 4 Unplug the power cord.

Inserting two size AA (R6) batteries into the remote

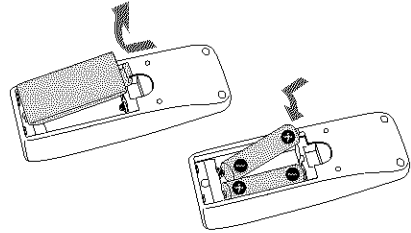

Tip

When the remote no longer operates the system, replace both batteries with new ones.

Note

If you do not use the remote for a long period of time, remove the batteries to avoid possible damage from battery leakage.

Setting the clock

- 1 Turn on the system.
- 2 Press **CLOCK/TIMER SET** on the remote.
- 3 Press **CLOCK/TIMER SET** on the remote to select "SET CLK", then press **ENTER**.
- 4 Press **⏪** or **⏩** on the remote repeatedly to set the hour.
- 5 Press **ENTER**.
- 6 Press **⏪** or **⏩** on the remote repeatedly to set the minute.
- 7 Press **ENTER**.

The clock starts working.

If you make a mistake

Perform from step 1.

Note

The clock settings are canceled when you disconnect the power cord or if a power failure occurs.

Loading the CD

1 Press DISC 1 – 3 ▲.

The disc tray opens.

2 Place a CD with the label side up on the tray.

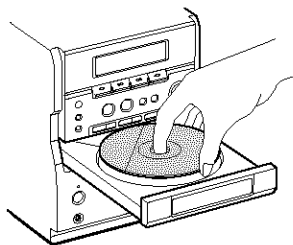

To load other CDs, press a different ▲ and place the CD in the disc tray.

3 Press the same ▲ again to close the disc tray.

Playing the CD

— Normal Play/Shuffle Play/Repeat Play

This system lets you play the CD in different play modes.

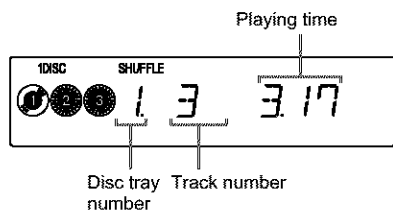

1 Press CD.

2 Press PLAY MODE repeatedly in stop mode until the mode you want appears in the display.

Select	To play
ALL DISCS (Normal Play)	All CDs in the disc tray continuously.
1 DISC (Normal Play)	The tracks on the CD you have selected in original order.

Select	To play
ALL DISCS SHUFFLE (Shuffle Play)	The tracks on all CDs in random order.
1 DISC SHUFFLE (Shuffle Play)	The tracks on the CD you have selected in random order.
PROGRAM (Program Play)	The tracks on the CDs in the order you want them to be played (see "Programming the CD tracks" on page 9).

3 Press ◀▶.

Other Operations

To	Do this
Stop playback	Press ■.
Pause	Press II. Press again to resume play.
Select a track	Turn ◀▶/▶▶ clockwise or counterclockwise (or press ◀▶ or ▶▶ on the remote).
Select a CD	<ul style="list-style-type: none"> Press DISC 1 – 3 and play starts automatically. Press DISC SKIP repeatedly so that DISC 1 – 3 appears. Press ◀▶ to play the selected CD.

If you press DISC 1 – 3 during play, the selected CD changes and the new CD starts playing.

Find a point in a track	During play, turn and hold ◀▶▶ clockwise or counterclockwise (or keep pressing ◀◀ or ▶▶ on the remote). Release it when you find the desired point.
Play repeatedly (Repeat Play)	Press REPEAT/DIR on the remote during play until "REPEAT" or "REPEAT 1" appears. REPEAT*: For all the tracks on the CD up to five times. REPEAT 1: For a single track only. To cancel playing repeatedly, press REPEAT/DIR on the remote until "REPEAT" or "REPEAT 1" disappears.

Remove the CD Press one of DISC 1 – 3 ▲ to open the tray that contains the CD you want to remove.

* You cannot select "REPEAT" and "ALL DISCS SHUFFLE" at the same time.

Programming the CD tracks

— Program Play

You can make a program of up to 25 tracks in the order you want them to be played.

- 1** Press **CD**, then place a CD.
- 2** Press **PLAY MODE** repeatedly in stop mode until “PROGRAM” appears in the display.
- 3** Press **DISC 1 – 3** to select a CD.
- 4** Turn **◀▶/▶▶** clockwise or counterclockwise (or press **◀◀** or **▶▶** on the remote) until the desired track appears in the display.

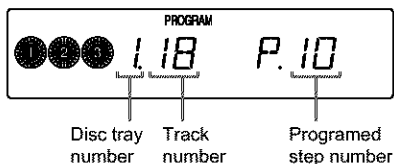

- 5** Press **ENTER**.
The track is programmed.
- 6** To program additional tracks, repeat steps 3 to 5.
- 7** Press **◀▶**.
Program Play starts.

To	Do this
Cancel Program Play	Press PLAY MODE until “PROGRAM” or “SHUFFLE” disappears from the display.
Add a track to the end of the program	Do steps 3 to 5 with Program Play stopped.
Erase the entire program	Press PGM CLEAR , when Program Play is in stop mode.

Tip

The program you made remains in the system’s memory even after it has been played back. Press **CD**, then press **◀▶** to play the same program again.

Note

If you open the disc tray, the program you made will be erased.

Presetting radio stations

You can preset up to 30 stations for FM and AM. You can then tune in any of those stations simply by selecting the corresponding preset number.

There are two ways to store the station presets.

To	Method
Automatically tune in all of the stations that can be received in your area and then store them manually	Automatic Tuning Preset
Manually tune in and store the radio frequency of your favourite stations	Manual Tuning Preset

Setting presets through automatic tuning

- 1 Press **TUNER** (**TUNER/BAND** on the remote) repeatedly to select “FM” or “AM”.
- 2 Turn and hold **TUNING +/-** (or press and hold **TUNING +** or **TUNING -** on the remote) until the frequency indication starts to change, then release it.

Scanning stops automatically when the system tunes in a station. “STEREO” (for a stereo program) appears.

If the scanning doesn't stop

Set the frequency of the desired radio station as described in steps 2 through 5 of “Setting presets through manual tuning”.

- 3 Press **TUNER MEM** (**TUNER MEMORY** on the remote).
The preset number starts flashing.
- 4 Press **PRESET** (**PRESET/CLOCK/TIMER** on the remote) + or - repeatedly to select the desired preset number.

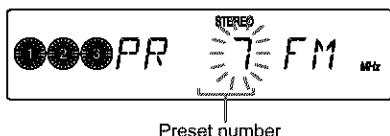

- 5 Press **ENTER**.
The station is stored.

- 6 Repeat steps 1 to 5 to store other stations.

Setting presets through manual tuning

- 1 Press **TUNER** (**TUNER/BAND** on the remote) repeatedly to select “FM” or “AM”.
- 2 Turn **TUNING +/-** (or press **TUNING +** or **TUNING -** on the remote) repeatedly to tune in the desired station.
- 3 Press **TUNER MEM** (**TUNER MEMORY** on the remote).
- 4 Press **PRESET** (**PRESET/CLOCK/TIMER** on the remote) + or - repeatedly to select the desired preset number.

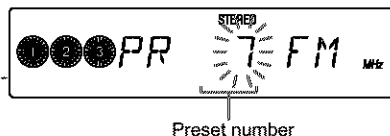

- 5 Press **ENTER**.
The station is stored.

- 6 Repeat steps 1 to 5 to store other stations.

Other Operations

To	Do this
Tune in a station with a weak signal	Follow the procedure described in “Setting presets through manual tuning”.
Change the preset number	Start over from step 1.
Change the preset station	Start over from step 1.

To change the AM tuning interval (except for the European model)

The AM tuning interval is factory-set to 9 kHz (10 kHz in some areas). To change the AM tuning interval, press and hold TUNER MEM on the unit for 4 seconds or more while the system is turned off. The AM tuning interval is toggled between 9 kHz and 10 kHz and the system is automatically turned on. When you change the interval, all the preset stations are erased. To reset the interval, repeat the same procedure.

Tip

The preset stations are retained for half a day even if you unplug the power cord or if a power failure occurs.

Listening to the radio

You can listen to a radio station either by selecting a preset station, or by manually tuning in the station.

Listening to a preset station

— Preset Tuning

Preset radio stations in the tuner's memory first (see "Presetting radio stations" on page 10).

- 1 Press TUNER (TUNER/BAND on the remote).
- 2 Press PRESET (PRESET/CLOCK/TIMER on the remote) + or – repeatedly to tune in the desired preset station.
The preset number appears in the display for a few seconds.

Listening to non-preset radio station

— Manual Tuning

- 1 Press TUNER (TUNER/BAND on the remote) repeatedly to select "FM" or "AM".
- 2 Turn and hold TUNING +/- (or press and hold TUNING + or TUNING – on the remote) repeatedly to tune in the desired station.

Tips

- To improve AM/FM broadcast reception, adjust the antennas.
- When an FM stereo program has static noise, press FM MODE/DIR (FM MODE on the remote) repeatedly until "MONO MODE" appears. There will be no stereo effect, but the reception will improve.
- You can tune in the radio program directly from other source by pressing TUNER (TUNER/BAND on the remote) (Automatic Source Selection).

Using the Radio Data System (RDS)

(European model only)

What is the Radio Data System?

Radio Data System (RDS) is a broadcasting service that allows radio stations to send additional information along with the regular program signal. This tuner offers convenient RDS features like station name and program type display. RDS is available only on FM stations.*

Note

RDS may not work properly if the station you are tuned in is not transmitting the RDS signal properly or if the signal strength is weak.

* Not all FM stations provide RDS service, nor do they provide the same types of services. If you are not familiar with the RDS system, check with your local radio stations for details on RDS services in your area.

Using the Radio Data System (RDS) (continued)

Receiving RDS broadcasts

Simply select a station from the FM band. When you tune in a station that provides RDS services, "RDS" appears in the display.

To check the RDS information

Each time you press DISPLAY, the display changes as follows:

Station name → Frequency → RDS TEXT →
Program type* (for five seconds) → Clock
display (for five seconds) → Station name →

...

* The types of programs include NEWS, AFFAIRS (current news), INFO, SPORT, EDUCATE (education programs), DRAMA, CULTURE, SCIENCE, VARIED (interviews, games and comedy), POP M, ROCK M, EASY M, LIGHT M, CLASSICS, OTHER M, WEATHER, FINANCE, CHILDREN, SOCIAL, RELIGION, PHONE IN, TRAVEL, LEISURE, JAZZ, COUNTRY, NATION M, OLDIES, FOLK M, DOCUMENT, TEST ALARM and NONE (any programs not defined above).

Loading a tape

- 1 Press **▲** PUSH OPEN/CLOSE.
- 2 Insert a tape in deck with the side you want to play/record facing up.

Insert with the side you want to play/record facing up.

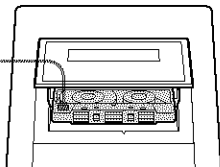

Playing a tape

You can use TYPE I (normal), TYPE II (CrO₂) or TYPE IV (metal) tape.

- 1 Load a recorded tape.
- 2 Press **TAPE**.
- 3 Press **FM MODE/DIR (REPEAT/DIR on the remote)** repeatedly to select **↔** to play one side, **↔↔** to play both sides, or **↔↔*** to play both sides repeatedly.
 - * The tape automatically stops after playing back five times.
- 4 Press **◀▶**.
Press **◀▶** again to play the reverse side.

To	Do this
Stop play	Press ■ .
Pause	Press ⏸ . Press again to resume play.
Fast-forward or rewind	With the tape stopped, turn ⏪/⏩ clockwise or counterclockwise (or press ◀◀ or ▶▶ on the remote).
Remove the cassette	Press ▲ PUSH OPEN/CLOSE.

Finding the beginning of a track (AMS*)

During playback, turn **⏪/⏩** clockwise or counterclockwise (or press **⏪** or **⏩** on the remote).

The tape is wound or rewound to the beginning of the next or current track, and play will start automatically. The search direction, “>> + 1” (forward) or “<< - 1” (back) appears in the display.

* AMS (Automatic Music Sensor)

Note

The AMS function may not operate correctly under the following circumstances:

- When the unrecorded space between tracks is less than 4 seconds long.
- When the system is placed near a television.

Recording to a tape

— CD Synchro Recording/Recording Manually

You can record from a CD or radio (or connected components). You can use TYPE I (normal) tape.

Steps	Recording from a CD (CD Synchro Recording)	Recording from the radio (or a connected component) manually
1	Load a blank tape.	
2	Press DISC 1 – 3 ▲.	Press TUNER (TUNER/BAND on the remote) or MD to select the desired source to record.
3	Load the CD you want to record.	Tune in the radio station (or load another audio source) you want to record.
4	Press ● REC PAUSE/START. The deck stands by for recording. When you want to record on the reverse side, press ◀▶.	
5	Press FM MODE/DIR (REPEAT/DIR on the remote) repeatedly to select ⇌ to record on one side, ⇔ to record on both sides.	
6	Press ● REC PAUSE/START again. Recording starts.	Press ● REC PAUSE/START again, and then start playing the desired source.

To stop recording

Press ■.

Tips

- When you record on both sides, be sure to start from the top side. If you start from the bottom side, recording stops at the end of the bottom side.
- For recording from the radio:
If noise is heard while recording from the radio, move the respective antenna to reduce the noise.

Note

To erase a recording, remove all the CDs, press CD, and then press ● REC PAUSE/START twice.

Recording a CD by specifying track order

— Program Edit

- 1 Load a recordable tape.
- 2 Program CD tracks following steps 1 to 6 in “Programming the CD tracks” on page 9.
- 3 Press ● REC PAUSE/START.
The tape deck stands by to record. The CD player stands by for playback.
- 4 Press FM MODE/DIR (REPEAT/DIR on the remote) repeatedly to select ⇄ to record on one side. Select ⇄⇄ to record on both sides.
- 5 Press ● REC PAUSE/START again.
Recording starts.

Timer-recording radio programs

To timer-record, you must preset the radio station (see “Presetting radio stations” on page 10) and set the clock (see “Setting the clock” on page 7) beforehand.

- 1 Press CLOCK/TIMER SET on the remote.
- 2 Press CLOCK/TIMER SET on the remote repeatedly until “SET TMR” appears, then press ENTER.
“ON” appears, and the hour indication flashes.
- 3 Set the starting time.

Press PRESET/CLOCK/TIMER + or – on the remote repeatedly to set the hour, then press ENTER.

The minute indication begins flashing next.

Press PRESET/CLOCK/TIMER + or – on the remote repeatedly to set the minute, then press ENTER.

- 4 Set the time to stop the recording following the procedure in step 3.
- 5 Press PRESET/CLOCK/TIMER + or – on the remote repeatedly until “RECORD” appears, then press ENTER.
- 6 Insert a recordable tape with the side you want to record on facing up.
- 7 Press PRESET/CLOCK/TIMER + or – on the remote repeatedly to tune in the desired preset station, then press ENTER.
- 8 Press I/O to turn off the system.

To	Do this
Check or change the setting	Turn on the system and then start over from step 1.
Activate the timer operation	Press CLOCK/TIMER ON/OFF on the remote until “REC” appears.
Cancel the timer operation	Press CLOCK/TIMER ON/OFF on the remote until “REC” and “DAILY” disappear.

Notes

- When you use the recording timer at the same time as the Sleep Timer, the Sleep Timer setting has priority.
- You cannot activate the Daily Timer and the recording timer at the same time.
- If the system is on at the preset time, the timer-recording will not be activated.
- The volume is reduced to minimum during recording.
- If the system is in the recording or recording-pause mode at the preset time, the timer recording will not be made.

Adjusting the sound

Reinforcing the bass sound

— MEGA BASS

You can listen to music with stronger bass tones.

Press MEGA BASS.

“MEGA BASS” appears in the display and the bass is reinforced.

Press again to cancel MEGA BASS.

Selecting the preset effect from the music menu

Press **MUSIC MENU** (or **MUSIC MENU +/-** on the remote) repeatedly to select the preset effect you desire.

Each time you press the button, the display changes cyclically as follows:

ROCK → POP → JAZZ → FLAT* → ROCK → ...

* “FLAT” is displayed for a few seconds.

To cancel the effect

Press **MUSIC MENU** (or **MUSIC MENU +/-** on the remote) repeatedly until “FLAT” appears.

Turning off the sound

— Muting

You can turn off the sound temporarily.

Press **MUTING** on the remote.

Press again to cancel muting.

Tip

You can also turn up the volume by turning **VOLUME** clockwise or turning off the power and turning it on again.

Falling asleep to music

— Sleep Timer

You can set the system to turn off after certain amount of time, so that you can fall asleep to music.

Press **SLEEP** on the remote.

Every time you press the button, the minute display (the turn-off time) changes as follows:
90 → 80 → 70 → ... → 10 → OFF → ...

To	Press
Check the remaining time	SLEEP on the remote once.
Change the time to turn off	SLEEP on the remote repeatedly to select the time you want.
Cancel the Sleep Timer function	SLEEP on the remote repeatedly until “SLEEP OFF” appears.

Waking up to music

— Daily Timer

You can wake up to music at a preset time. Make sure you have set the clock (see “Setting the clock” page 7).

- 1 Prepare the sound source you want to play.**
 - CD: Place a CD.
 - Tape: Insert a tape with the side you want to play on facing up.
 - Radio: Tune in the station you want (see “Listening to the radio” on page 11).
- 2 Adjust the volume.**
- 3 Press CLOCK/TIMER SET on the remote.**
- 4 Press CLOCK/TIMER SET on the remote repeatedly until “SET TMR” appears, then press ENTER.** “ON” appears, and the hour indication flashes.

5 Set the starting time.

Press **PRESET/CLOCK/TIMER** + or – on the remote repeatedly to set the hour, then press **ENTER**.

The minute indication begins flashing next.

Press **PRESET/CLOCK/TIMER** + or – on the remote repeatedly to set the minute, then press **ENTER**.

6 Set the time to stop the playback following the procedure in step 5.**7** Press **PRESET/CLOCK/TIMER** + or – on the remote to select the desired sound source.

The indication changes as follows:

TUNER → CD → TAPE → RECORD
→ TUNER → ...

8 Press **ENTER**.**9** Press **I/⏻** to turn off the system.

To	Do this
Check or change the setting	Turn on the system and then start over from step 1.
Activate the timer operation	Press CLOCK/TIMER ON/OFF on the remote until “DAILY” appears.
Cancel the timer	Press CLOCK/TIMER ON/OFF on the remote until “DAILY” and “REC” disappear.

Tip

The system automatically turns on 1 minute before the preset time.

Note

The radio station selected for the Daily Timer is the one that you tuned in before you turned off the system.

Turning off the display**— Power Saving Mode**

Even if the system is off, the system consumes power to display the clock and to stay responsive to commands from the remote. Power Saving mode reduces the amount of power consumed during standby.

In this mode, the clock is not displayed.

Press **DISPLAY** while the system is off until the clock display disappears.

To cancel the Power Saving mode

Press **DISPLAY** while the system is off.

The display changes as follows:

Clock display* ↔ No display (Power Saving mode)

* “--:--” is displayed if you do not set the clock.

Tip

The timer continues to operate in Power Saving mode.

Using the CD display

Press **DISPLAY** repeatedly.

The display changes as follows:

During normal play

Elapsed playing time on the current track →
Remaining time on the current track →
Remaining time on the current CD → Clock display (for five seconds) → Elapsed playing time on the current track → ...

In the stop mode

Total number of tracks and total playing time → Clock display (for five seconds) → Total number of tracks and total playing time → ...

Hooking up optional components

You can connect a digital or an analogue component to this system.

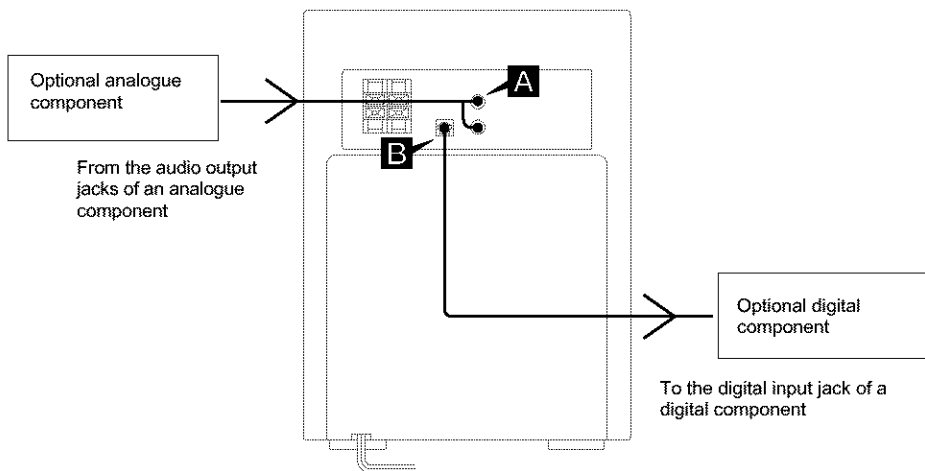

A MD IN jacks

Use audio cords (not supplied) to connect an optional component (such as an MD player) to these jacks. You can then record or listen to analogue audio from that component through this system.

B OPTICAL DIGITAL OUT jack

Use a digital cable (square, not supplied) to connect an optional digital component (such as an MD recorder) to this jack. You can then make a digital recording from this system to that digital component.

Listening to audio from a connected component

- 1 Connect the audio cords.**
See "Hooking up optional components" above.
- 2 Press MD to switch the function to MD.**
Start playing the connected component.

Recording a CD on a connected digital component

- 1 Connect the digital cable.**
See "Hooking up optional components" above.
- 2 Start recording.**
Refer to the operating instructions provided with the connected component.

Recording audio from a connected component

- 1 Connect the audio cords.**
See "Hooking up optional components" above.
- 2 Start recording manually.**
See "Recording to a tape" on page 14.

Problems and remedies

If you have any problem using this system, use the following check list.

First, check that the power cord is connected firmly and the speakers are connected correctly and firmly.

Should any problem persist, consult your nearest Sony dealer.

General

The display or button remains lighted or flashes even after the system was turned off.

- Press DISPLAY on the remote repeatedly until the clock display appears.

The clock indication does not show the correct time.

- A power interruption occurred. Set the clock and timer settings again.

The clock setting/radio presetting/timer is canceled.

- The power cord is disconnected or a power failure occurs longer than half a day.

Redo the following:

- “Setting the clock” on page 7
- “Presetting radio stations” on page 10

If you have set the timer, also redo “Timer-recording radio programs” on page 15 and “Waking up to music” on page 16.

There is no sound.

- Turn VOLUME clockwise and hold.
- The headphones are connected.
- Insert only the stripped portion of the speaker cord into the SPEAKER terminal. Inserting the vinyl portion of the speaker cord will obstruct the speaker connections.

There is severe hum or noise.

- A TV or VCR is placed too close to the stereo system. Move the stereo system away from the TV or VCR.

The timer does not function.

- Set the clock correctly.
- You cannot activate the Timer-recording and Daily Timer at the same time.
- When you used the Sleep Timer, Daily Timer and Timer-recording will not turn on the system until the Sleep Timer turns it off.

The remote does not function.

- There is an obstacle between the remote and the system.
- The remote is not pointing in the direction of the system’s sensor.
- The batteries have run down. Replace the batteries.

The color irregularity on a TV screen persists.

- Turn off the TV set once, then turn it on after 15 to 30 minutes. If the color irregularity still persists, place the speakers farther away from the TV set.

Speakers

Sound comes from one channel or unbalanced left and right volume.

- Check the speaker connection and speaker placement.

Sound lacks bass.

- Check that the speaker’s + and – terminals are connected correctly.

CD Player

The CD tray does not open/close.

- The CD is not placed properly.
- The system is not placed horizontally on a flat and solid stand.

The CD does not change.

- The system is not placed horizontally on a flat and solid stand.

The CD will not play.

- The CD is not lying flat on the CD tray.
- The CD is dirty.
- The CD is inserted label side down.
- Moisture condensation has built up. Remove the CD and leave the system turned on for about an hour until the moisture evaporates.

The disc tray does not open and “LOCKED” appears.

- Contact your Sony dealer or local authorized Sony service facility.

continued

Problems and remedies (continued)

The disc tray does not open and “CD ERR 1” or “CD ERR 2” appears.

- A foreign object is caught in the drive. Remove it, turn the system off, and turn the system on again.
-

Tape Deck

The tape does not record.

- No tape in the cassette compartment.
 - The tab has been removed from the cassette.
 - The tape has reeled to the end.
-

The tape does not record nor play or there is a decrease in sound level.

- The heads are dirty. Clean them (see “Cleaning the tape heads” on page 22).
 - The record/playback heads are magnetized. Demagnetize them (see “Demagnetizing the tape heads” on page 22).
-

The tape does not erase completely.

- The record/playback heads are magnetized. Demagnetize them (see “Demagnetizing the tape heads” on page 22).
-

There is excessive wow or flutter, or the sound drops out.

- The capstans or pinch rollers are dirty. Clean them (see “Cleaning the tape heads” on page 22).
-

Noise increases or the high frequencies are erased.

- The record/playback heads are magnetized. Demagnetize them (see “Demagnetizing the tape heads” on page 22).
-

Tuner

Noise is heard.

- Adjust the antennas.
-

A stereo FM program cannot be received in stereo.

- Press FM MODE/DIR (FM MODE on the remote) until “STEREO MODE” appears in the display.
-

If the system still does not operate properly after performing the measures explained on pages 19 and 20, reset the system as follows:

- 1 Remove the power cord from the wall outlet, wait for 30 seconds or more, then connect the power cord to the wall outlet again.
- 2 Turn off the system and press MEGA BASS, ■ (stop) and TAPE simultaneously.
All system parameters are reset to their factory settings.

Messages

The following message may appear in the display during operations.

NO DISC

- There is no disc on the disc tray.
-

TRAY/PROTECT

- The system is not placed horizontally on a flat and solid surface.
-

Precautions

On operating voltage

Before operating the system, check that the operating voltage of your system is identical with the voltage of your local power supply.

On safety

- The system is not disconnected from the AC power source (mains) as long as it is connected to the wall outlet, even if the system itself has been turned off.
- Unplug the system from the wall outlet (mains) if it is not to be used for an extended period of time. To disconnect the cord (mains lead), pull it out by the plug. Never pull the cord itself.
- Should any solid object or liquid fall into the component, unplug the stereo system and have the component checked by qualified personnel before operating it any further.
- The AC power cord must be changed only at a qualified service shop.
- The nameplate is located on the bottom exterior.

On placement

- Place the system in a location with adequate ventilation to prevent heat build-up the system.
- Do not place the system in an inclined position.
- Do not place the system in locations where it is;
 - Extremely hot or cold
 - Dusty or dirty
 - Very humid
 - Vibrating
 - Subject to direct sunlight.
- Use caution when placing the unit or speakers on surfaces that have been specially treated (with wax, oil, polish, etc.) as staining or discoloration of the surface may result.

On heat buildup

- Although the system heats up during operation, this is not malfunction.
- Place the system in a location with adequate ventilation to prevent heat build-up in the system.

If you continuously use this system at a large volume, the cabinet temperature of the top, side and bottom rises considerably. To avoid burning yourself, do not touch the cabinet.

To prevent a malfunction, do not cover the ventilation hole.

On operation

- If the system is brought directly from a cold to a warm location, or is placed in a very damp room, moisture may condense on the lens inside the CD player. Should this occur, the system will not operate properly. Remove the CD and leave the system turned on for about an hour until the moisture evaporates.
- When you move the system, take out any discs.

If you have any questions or problems concerning your stereo system, please consult your nearest Sony dealer.

Notes on CDs

- Before playing, clean the CD with a cleaning cloth. Wipe the CD from the center out.
- Do not use solvents.
- Do not expose the CD to direct sunlight or heat sources.
- Discs with non-standard shapes (e.g., heart, square, star) cannot be played on this system. Attempting to do so may damage the system. Do not use such discs.

Note on CD-R/CD-RW playback

Discs recorded on CD-R/CD-RW drives may not be played back because of scratches, dirt, recording condition or the drive's characteristics. Besides, the discs, which are not yet finalized at the end of recording cannot be played back.

Cleaning the cabinet

Use a soft cloth slightly moistened with mild detergent solution.

To save a tape permanently

To prevent a tape from being accidentally recorded over, break off the cassette tab from side A or B as illustrated.

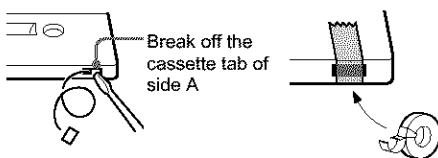

If you later want to reuse the tape for recording, cover the broken tab with adhesive tape.

continued

Precautions (continued)

Before placing a cassette in the tape deck

Take up any slack in the tape. Otherwise the tape may get entangled in the parts of the tape deck and become damaged.

When using a tape longer than 90 minutes

The tape is very elastic. Do not change the tape operations such as play, stop, and fast-winding (etc.) frequently. The tape may get entangled in the tape deck.

Cleaning the tape heads

Clean the tape heads after every 10 hours of use. Make sure to clean the tape heads before you start an important recording or after playing an old tape. Use separately sold dry-type or wet-type cleaning cassette. For details, refer to the instructions of the cleaning cassette.

Demagnetizing the tape heads

Demagnetize the tape heads and the metal parts that have contact with the tape every 20 to 30 hours of use with a separately sold demagnetizing cassette. For details, refer to the instructions of the demagnetizing cassette.

Specifications

AUDIO POWER SPECIFICATIONS: (U.S.A. model only)

POWER OUTPUT AND TOTAL HARMONIC DISTORTION:

with 4 Ω loads both channels driven, from 120 ~ 10,000 Hz; rates 15 W per channel minimum RMS power, with no more than 10% total harmonic distortion from 250 mW to rated output.

Amplifier section

Canadian model:

Continuous RMS power output (reference)
15 + 15 W
(4 Ω at 1 kHz, 10% THD)

European model:

DIN power output (rated) 12 + 12 W
(4 Ω at 1 kHz, DIN)
Continuous RMS power output (reference)
15 + 15 W
(4 Ω at 1 kHz, 10% THD)
Music power output (reference)
38 + 38 W

Other model:

The following measured at AC 230 V or AC 120 V, 50/60 Hz
DIN power output (rated) 12 + 12 W
(4 Ω at 1 kHz, DIN)
Continuous RMS power output (reference)
15 + 15 W
(4 Ω at 1 kHz, 10% THD)

Inputs

MD IN (phono jacks): voltage 450 mV,
impedance 47 kilohms

Outputs

PHONES: Accepts headphones of
(stereo mini jack) 8 Ω or more
SPEAKER: Accepts impedance of 8 to
16 Ω

CD player section

System	Compact disc and digital audio system
Laser	Semiconductor laser ($\lambda=780$ nm) Emission duration: continuous
Frequency response	20 Hz - 20 kHz (± 0.5 dB)
OPTICAL DIGITAL OUT (Square optical connector jack, rear panel)	
Wavelength	660 nm

Tape player section

Recording system	4-track 2-channel stereo
Frequency response	50 - 13 000 Hz (± 3 dB), using Sony TYPE I cassette
Wow and flutter	$\pm 0.15\%$ W.Peak (IEC) 0.1% W.RMS (NAB) $\pm 0.2\%$ W.Peak (DIN)

Tuner section

FM stereo, FM/AM superheterodyne tuner

FM tuner section

Tuning range	87.5 - 108.0 MHz
Antenna	FM lead antenna
Antenna terminal (Except for European model)	75 Ω coaxial
Intermediate frequency	10.7 MHz

AM tuner section

Tuning range	
Pan-American model:	530 - 1 710 kHz (with the interval set at 10 kHz) 531 - 1 710 kHz (with the interval set at 9 kHz)
European model:	531 - 1 602 kHz (with the interval set at 9 kHz)
Other models:	531 - 1 602 kHz (with the interval set at 9 kHz) 530 - 1 710 kHz (with the interval set at 10 kHz)
Antenna	AM loop antenna
Intermediate frequency	450 kHz

Speaker

Speaker system	Bass-reflex type
Speaker units	
Woofer:	10 cm, cone type
Tweeter:	5 cm, cone type
Nominal impedance	4 Ω
Dimensions (w/h/d)	Approx. 170 \times 246 \times 185 mm
Mass	Approx. 2.2 kg

General

Power requirements	
North American model :	120 V AC, 60 Hz
European model:	230 V AC, 50/60 Hz
Other models:	230 V AC, 50/60 Hz

Power consumption	
U.S.A. model:	38 W
Canadian model:	38 W
European model:	38 W
	0.5 W (in the standby mode)
Other models:	38 W

Dimensions (w/h/d): Approx. 180 \times 246 \times 335 mm

Mass: Approx. 5.0 kg

Supplied accessories:	AM loop antenna (1) Remote Commander (1) Batteries (2) FM lead antenna (1) (Except for European model)
-----------------------	--

Design and specifications are subject to change without notice.



Sony Corporation Printed in China

<http://www.sony.net/>