

# ***CD Radio Cassette-Corder***

---

Operating Instructions

***CFD-S20CP***

## Warning

**To prevent fire or shock hazard, do not expose the player to rain or moisture.**

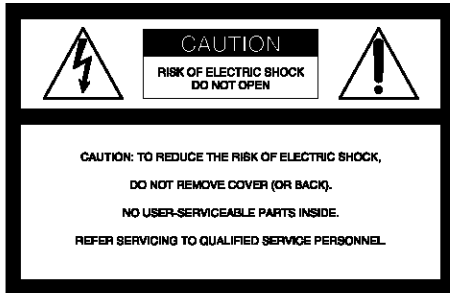

This symbol is intended to alert the user to the presence of uninsulated “dangerous voltage” within the product’s enclosure that may be of sufficient magnitude to constitute a risk of electric shock to persons.



This symbol is intended to alert the user to the presence of important operating and maintenance (servicing) instructions in the literature accompanying the appliance.

## CAUTION

The use of optical instruments with this product will increase eye hazard.

## WARNING

Do not install the appliance in a confined space, such as a bookcase or built-in cabinet.

To prevent fire or shock hazard, do not place objects filled with liquids, such as vases, on the appliance.

## For customers in Canada

To prevent electric shock, match wide blade of plug to wide slot, fully insert.

## Information

### For customers in the United States

This equipment has been tested and found to comply with the limits for a Class B digital device, pursuant to Part 15 of the FCC Rules. These limits are designed to provide reasonable protection against harmful interference in a residential installation. This equipment generates, uses and can radiate radio frequency energy and, if not installed and used in accordance with the instructions, may cause harmful interference to radio communications. However, there is no guarantee that interference will not occur in a particular installation. If this equipment does cause harmful interference to radio or television reception, which can be determined by turning the equipment off and on, the user is encouraged to try to correct the interference by one or more of the following measures:

- Reorient or relocate the receiving antenna.
- Increase the separation between the equipment and receiver.
- Connect the equipment into an outlet on a circuit different from that to which the receiver is connected.
- Consult the dealer or an experienced radio/TV technician for help.

You are cautioned that any changes or modifications not expressly approved in this manual could void your authority to operate this equipment.

## Owner's Record

The model number is located at the bottom and the serial number is located in the battery compartment.

Record the serial number in the space provided below. Refer to these numbers whenever you call upon your Sony dealer regarding this product.

Model No. CFD-S20CP

Serial No. \_\_\_\_\_

# Table of contents

## Basic Operations

Playing an audio CD or MP3 files .....	4
Listening to the radio .....	8
Playing a tape .....	10
Recording on a tape .....	12

### The CD Player

Using the display .....	14
Locating a specific track .....	15
Playing tracks repeatedly (Repeat Play) .....	16
Playing tracks in random order (Shuffle Play) .....	17
Creating your own program (Program Play) .....	17

### The Radio

Presetting radio stations .....	19
Playing preset radio stations .....	20

### The Audio Emphasis

Adjusting the sound emphasis .....	21
------------------------------------	----

### The Timer

Falling asleep to music .....	22
-------------------------------	----

### Setting Up

Choosing the power sources .....	23
----------------------------------	----

### Additional Information

Precautions .....	24
Troubleshooting .....	26
Maintenance .....	28
Specifications .....	29
About "MP3" .....	30
Index .....	31

# Playing an audio CD or MP3 files

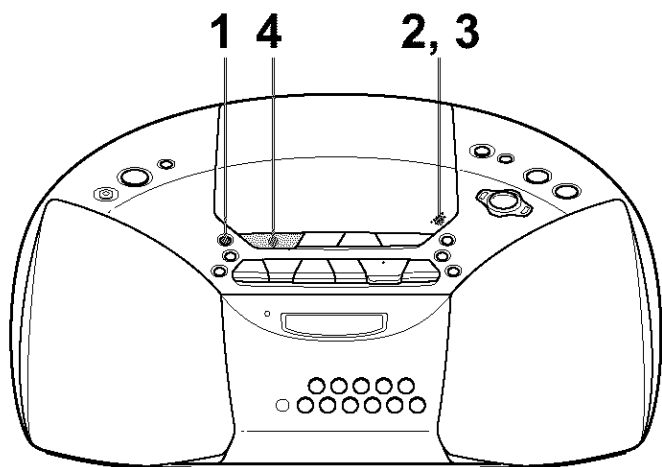

Connect the supplied AC power cord (see page 23).

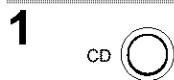

Press CD.

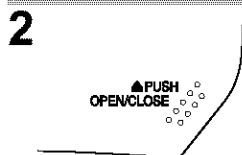

Press PUSH OPEN/CLOSE down to open the CD compartment and place the CD on the CD compartment.

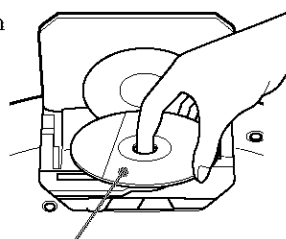

With the label side up

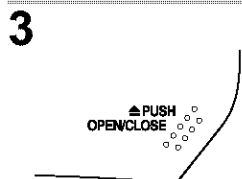

Close the lid of the CD compartment.

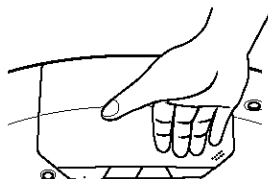

# 4



Press **▶||** (▶ on the remote).  
 The player plays all the tracks once.  
 To play a CD with MP3 files, see page 6.

### Display

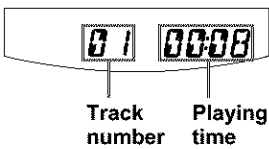

## Use these buttons for additional operations

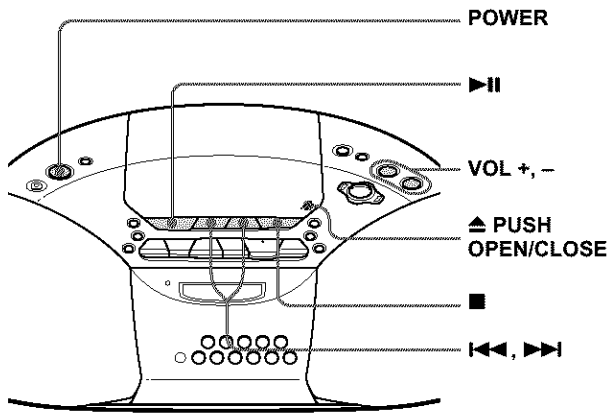

### Tip

Playback starts from the track you last stopped playing (Resume play). During stop, the track number to be played are displayed.  
 To cancel the resume play to start play from the beginning of the first track, press **■** in stop mode.

To	Do this
adjust the volume	Press VOL +*, -.
stop playback	Press <b>■</b> .
pause playback	Press <b>▶  </b> * (   on the remote). Press the button again to resume play after pause.
go to the next track	Press <b>▶▶</b> .
go back to the previous track	Press <b>◀◀</b> .
remove the CD**	Press <b>▲</b> PUSH OPEN/CLOSE.
turn on/off the player	Press POWER.

\* The button has a tactile dot.  
 \*\*Once you open the CD compartment, the track to start play will change to the beginning of the first track.

**continued**

## Playing an audio CD or MP3 files (continued)

### Playing a CD with MP3 files

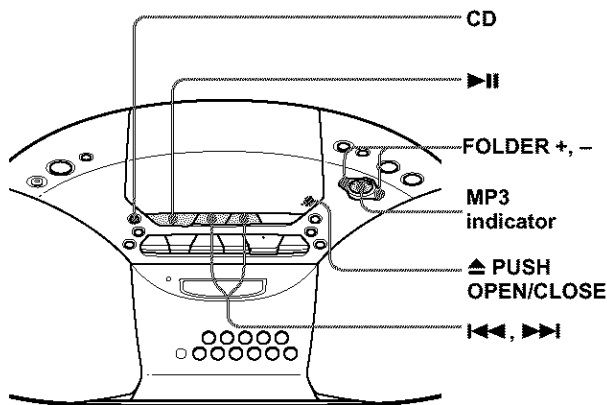

#### Note

Before playing a file, this player reads all file and folder information on the CD. Depending on the file structure, it may take more than a minute to read them. During this time, “Reading” is displayed.

#### Tip

You can use the buttons mentioned in the table on page 5 for additional operations in the same way as when playing an audio CD.

- 1 Press CD.
- 2 Press ▲ PUSH OPEN/CLOSE to open the CD compartment and place the CD on the CD compartment (see page 4) .
- 3 Close the lid of the CD compartment.
- 4 Press ▶||.  
The player plays all MP3 files on the CD.  
When you play a CD with MP3 files, the MP3 indicator lights up.



Track number

After the file name is displayed, the playing time will appear

#### To select a folder

Press FOLDER + to go forward and FOLDER – to go backward (press FLDR + or FLDR – on the remote).

#### To select a file

Press ▶▶ to go forward and ◀◀ to go backward.

## Notes

- A folder that does not include an MP3 file is skipped.
- Maximum number of folders: 255  
Maximum number of files: 255
- Folder names and file names can be displayed with up to 64 characters.
- The characters A - Z, a - z, 0 - 9, and \_ can be displayed on this player. Other characters are displayed as “\*”.
- This player conforms to Version 1.1 of the ID3 tag format. If the file has the ID3 tag information, “song title”, “artist name” and “album name” can be displayed.

## Example of folder structure and playing order

The playing order of the folders and files is as follows:

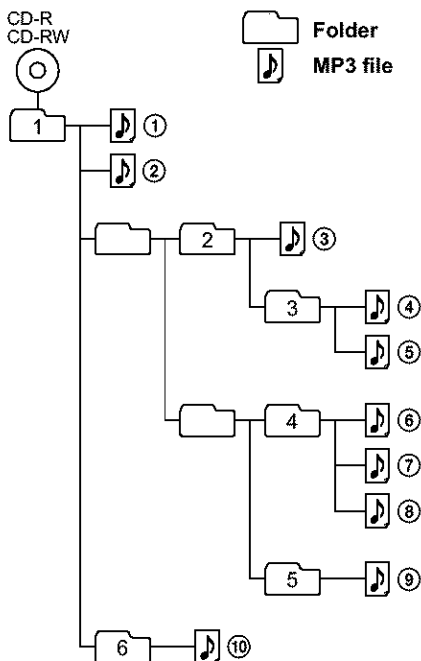

## About CD-Rs/CD-RWs and MP3 files

This player can play CD-Rs/CD-RWs recorded in the CD-DA format\* and MP3 files recorded in the CD-ROM format, but playback capability may vary depending on the quality of the disc and the condition of the recording device.

\* CD-DA is the abbreviation for Compact Disc Digital Audio. It is a recording standard used for Audio CDs.

# Listening to the radio

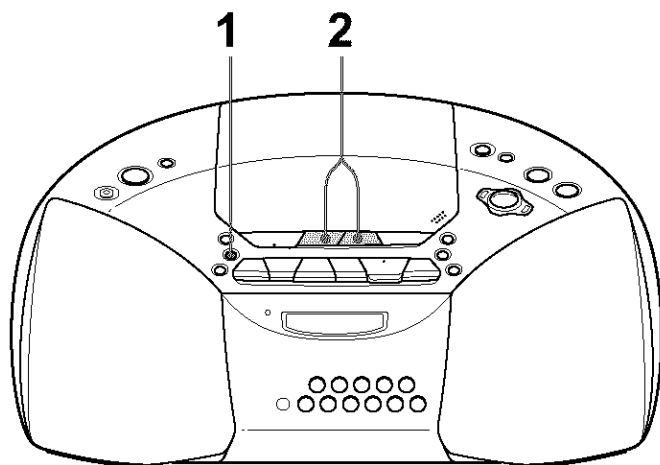

Connect the supplied AC power cord (see page 23).

**1**

RADIO BAND  
AUTO PRESET



Press RADIO BAND•AUTO PRESET until the band you want appears in the display.

Display

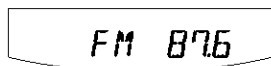

**2**

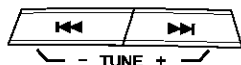

Hold down TUNE + or – until the frequency digits begin to change in the display.

The player automatically scans the radio frequencies and stops when it finds a clear station.

If you can't tune in a station, press TUNE + or – repeatedly to change the frequency step by step.

Indicates an FM stereo broadcast

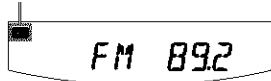



**Use these buttons for additional operations**

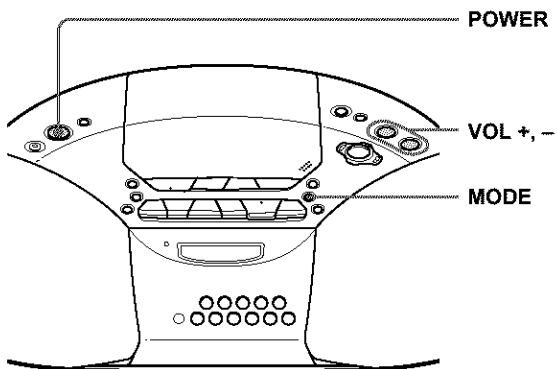

**Tip**

If the FM broadcast is noisy, press MODE until "Mono" appears in the display and radio will play in monaural.

To	Press
adjust the volume	VOL +*, -
turn on/off the radio	POWER

\*VOL + has a tactile dot.

**To improve broadcast reception**

Reorient the antenna for FM. Reorient the player itself for AM.

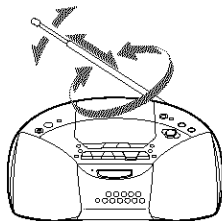

for FM

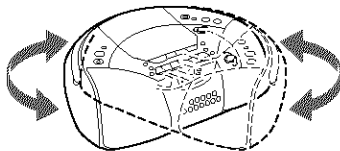

for AM

# Playing a tape

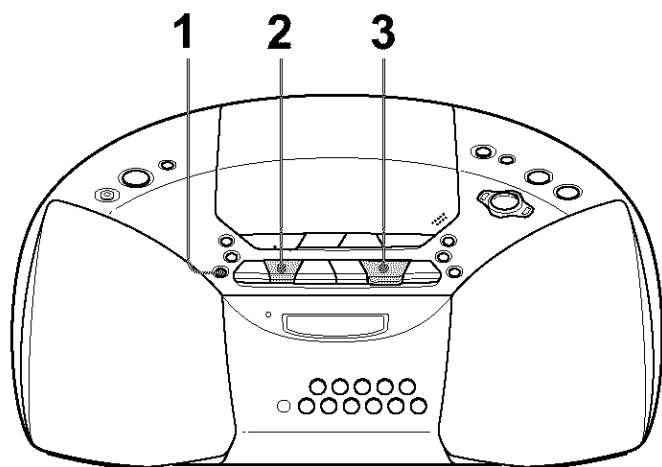



Connect the supplied AC power cord (see page 23).





Press TAPE.

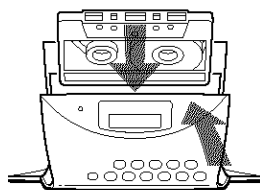

Press   to open the tape compartment and insert a recorded tape. Use TYPE I (normal) tape only. Close the compartment.

**With the side you want to play facing you**



Press .  
The player starts playing.

Display

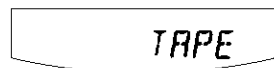

## Use these buttons for additional operations

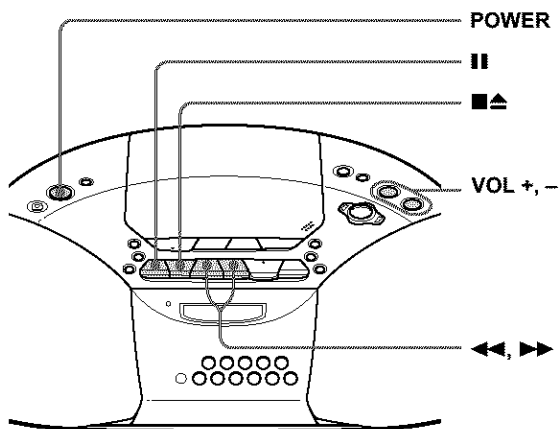

To	Press
adjust the volume	VOL +*, -
stop playback	■▲
fast-forward or rewind	◀◀ or ▶▶
pause playback	II Press the button again to resume play after pause.
eject the cassette	■▲
turn on/off the player	POWER

\*VOL + and ◀ has a tactile dot.

# Recording on a tape

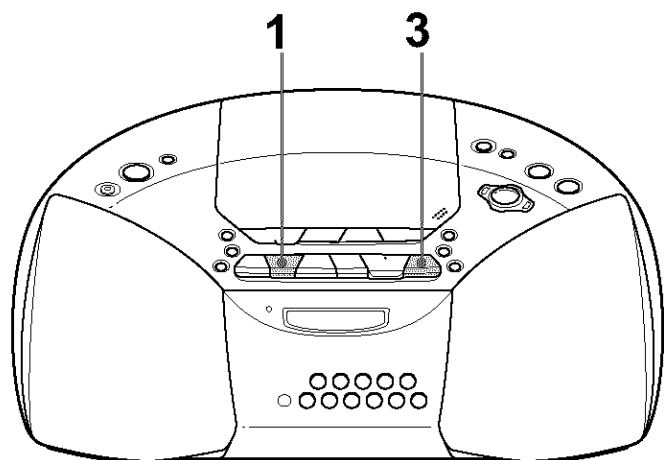

Connect the supplied AC power cord (see page 23).

1



Press  to open the tape compartment and insert a blank tape. Use TYPE I (normal) tape only. Close the compartment.

With the side you want to record on facing you

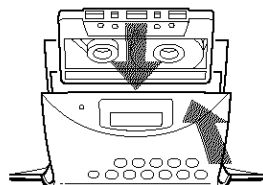

2

Select the program source you want to record.



To record from the CD player, insert a CD (see page 4) and press CD.

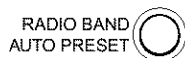

To record from the radio, tune in the station you want (see page 8).

Display

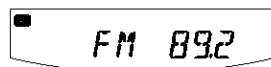
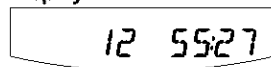

3



Press ● to start recording  
(◀ is depressed automatically).

**Use these buttons for additional operations**

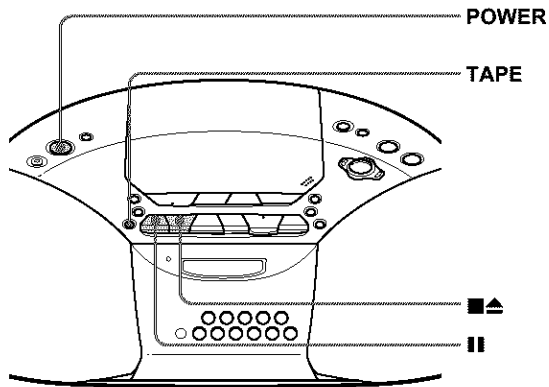

**Tips**

- Adjusting the volume or the audio emphasis (see page 21) will not affect the recording level.
- If the AM program makes a whistling sound after you've pressed ● in step 3, press MODE to select the position of ISS (Interference Suppress Switch) that most decreases the noise.
- For the best results, use the AC power as a power source.
- To erase a recording, proceed as follows:
  - 1 Insert the tape whose recording you want to erase.
  - 2 Press TAPE.
  - 3 Press ●.

To	Press
stop recording	■▲
pause recording	
	Press the button again to resume recording.
turn on/off the player	POWER

## Using the display

You can check information about the CD using the display.

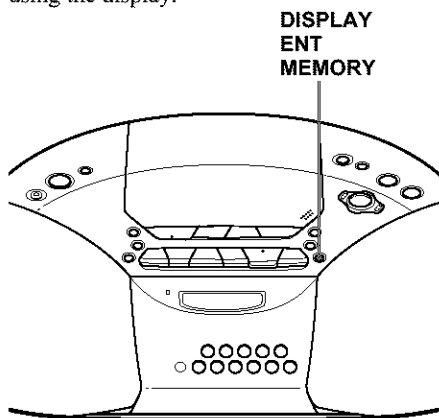

### Checking the information of an audio CD

#### To check the total track number and playing time of the CD

While the CD is stopped, you can check them in the display.

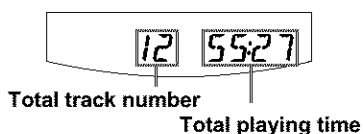

#### To check the remaining time

Press DISPLAY•ENT•MEMORY while playing a CD. The display changes as follows:

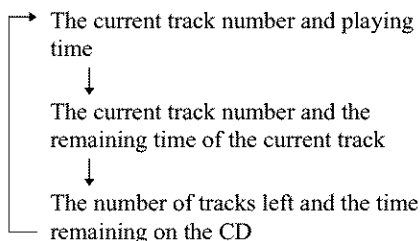

### Checking the information of a CD with MP3 files

#### To check the total folder number and total track number on the CD

While the CD is stopped, you can check them in the display.

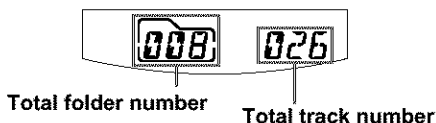

#### To check file information

Press DISPLAY•ENT•MEMORY while playing an MP3 file. The display changes as follows:

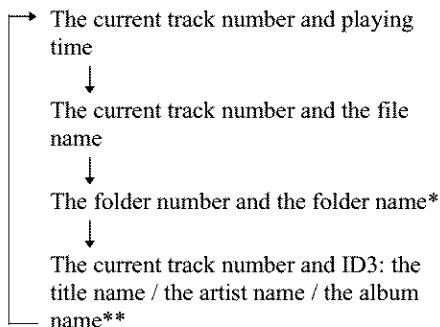

\* If the folder does not have a folder name, "Root" appears instead of a folder name.

\*\* If the file does not have ID3 information, "No Title", "No Artist" or "No Album" appears in the display.

## Locating a specific track

You can quickly locate any track on a CD using the number buttons.

You can also find a specific point in a track while playing a CD.

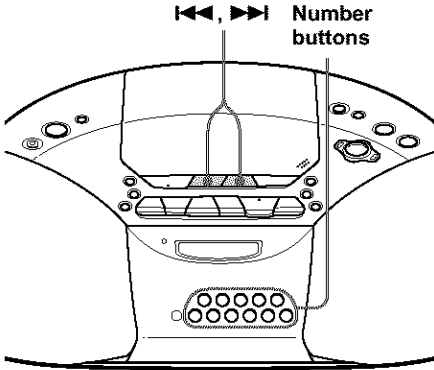

To locate	Press
a specific track directly	the number button of the track
a point while listening to the sound	▶▶ (forward) or ◀◀ (backward) while playing and hold it until you find the point
a point while observing the display	▶▶ (forward) or ◀◀ (backward) in pause and hold it until you find the point

### Notes

- Locating a specific track using the number buttons is only available for the tracks in the selected folder.
- You cannot locate a specific track if "SHUF" or "PGM" is lit in the display. Turn off the indication by pressing ■.

### Tips

- When you locate a track numbered over 10, press >10 first, then the corresponding number buttons.  
Example: To play track number 23, press >10 first, then 2 and 3.
- To select a track numbered over 100 or more, press >10 twice, then the corresponding number buttons.

# Playing tracks repeatedly (Repeat Play)

You can play tracks repeatedly in normal, shuffle or program play modes.

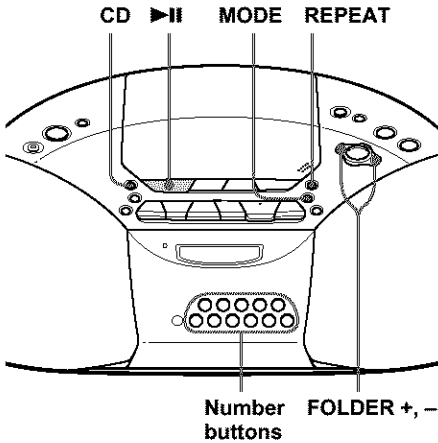

**1** Press CD.  
“CD” appears in the display.

**2** Proceed as follows.

To repeat	Do this
a single track	<ol style="list-style-type: none"> <li>1 Press REPEAT until “REP I” appears.</li> <li>2 Press the number button for the track you want to repeat.</li> </ol>
all tracks on the CD	<ol style="list-style-type: none"> <li>1 Press REPEAT until “REP ALL” appears.</li> <li>2 Press ►  .</li> </ol>
a selected folder (MP3 CD only)	<ol style="list-style-type: none"> <li>1 Press REPEAT until “REP FLDR” appears.</li> <li>2 Select the folder by pressing FOLDER + or FOLDER –, then press ►  .</li> </ol>
tracks in random order	<ol style="list-style-type: none"> <li>1 Start Shuffle Play (see page 17).</li> <li>2 Press REPEAT until “SHUF REP” appears.</li> </ol>

To repeat	Do this
programed tracks	<ol style="list-style-type: none"> <li>1 Program tracks (see step 3 on page 18).</li> <li>2 Press REPEAT until “PGM REP” appears.</li> <li>3 Press ►  .</li> </ol>
programed folders	<ol style="list-style-type: none"> <li>1 Program folders (see step 3 on page 18).</li> <li>2 Press REPEAT until “FLDR PGM REP” appears.</li> <li>3 Press ►  .</li> </ol>

## To cancel Repeat Play

Press REPEAT until “REP” disappears from the display.

## When playing MP3 files

When you select “REP ALL”, the player plays all files (up to 255 files) of a CD repeatedly.



## Playing tracks in random order (Shuffle Play)

You can play tracks in random order.

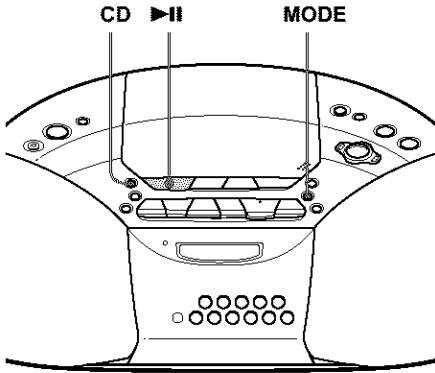

- 1 Press CD.  
"CD" appears in the display.
- 2 Press MODE until "SHUF" appears in the display.
- 3 Press ►|| to start Shuffle Play.

### To cancel Shuffle Play

Stop playing first. Then press MODE until "SHUF" disappears from the display.

### When playing MP3 files

The player plays all files (up to 255 files) on a CD in random order.

### Tips

- During Shuffle Play, you cannot select the previous track by pressing ◀◀.
- The resume function doesn't work during Shuffle Play.

## Creating your own program (Program Play)

You can arrange the playing order of up to 20 tracks or files on a CD. When playing an MP3 files, you can also program up to 20 folders (Program Folder Play).

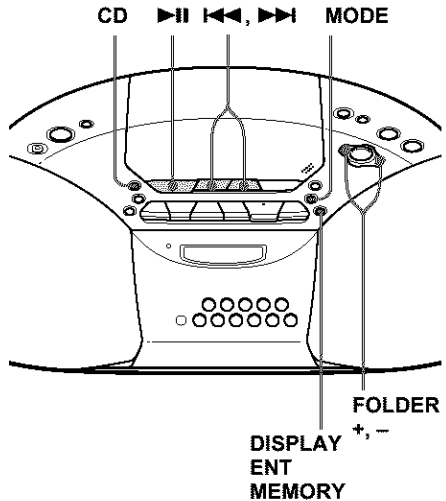

- 1 Press CD.  
"CD" appears in the display.
- 2 Press MODE until "PGM" appears in the display.  
When you select Program Folder Play (MP3 CD only), press MODE until "PGM FLDR" appears in the display.

***continued***

## Creating your own program (Program Play) (continued)

- 3 Press **◀◀** or **▶▶**, **FOLDER +** or **-** then press **DISPLAY•ENT•MEMORY** for the tracks or files\* you want to program in the order you want.  
\*folders for Program Folder Play.

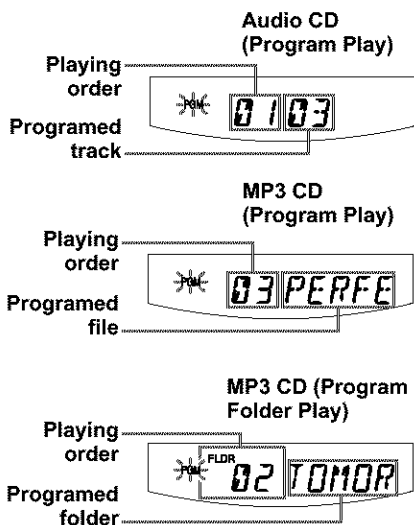

- 4 Press **▶||** to start Program Play.

### To cancel Program Play

Stop playing first. Then press **MODE** until "PGM" disappears from the display.

### To check the order of tracks before play

Press **DISPLAY•ENT•MEMORY**.

Every time you press the button, the track or folder number appears in the programmed order.

### To change the current program

Press **■** once if the CD is stopped and twice if the CD is playing. The current program will be erased. Then create a new program following the programming procedure.

### Tips

- You can play the same program again, since the program is saved until you open the CD compartment.
- You can record your own program. After you've created the program, insert a blank tape and press **●** to start recording.
- The resume function doesn't work during Program Play.

## Presetting radio stations

You can store radio stations into the player's memory. You can preset up to 30 radio stations, 20 for FM and 10 for AM in any order.

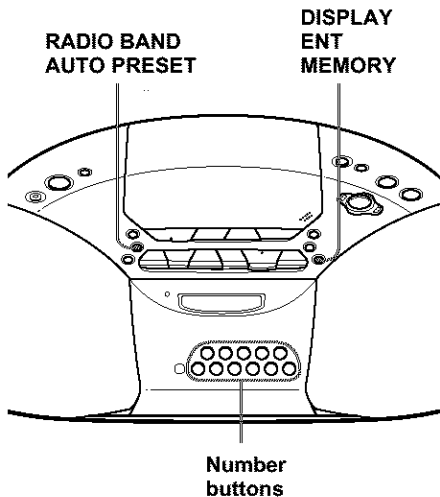

- 1** Press RADIO BAND•AUTO PRESET to select the band.
- 2** Hold down RADIO BAND•AUTO PRESET until "AUTO" flashes in the display.
- 3** Press DISPLAY•ENT•MEMORY. The stations are stored in memory from the lower frequencies to the higher ones.

### If a station cannot be preset automatically

You need to preset a station with a weak signal manually.

- 1** Press RADIO BAND•AUTO PRESET to select the band.
- 2** Tune in a station you want.
- 3** Hold down the number buttons that you want to preset the new station on for about 2 seconds.

To select the preset number over 10, press >10 first, then the corresponding number buttons.

You need to hold down the last number button to enter for about 2 seconds. (Example: To select 12, press >10 and 1 first, then hold down 2 for about 2 seconds.)

# Playing preset radio stations

Once you've preset the stations, use the number buttons to tune in your favorite stations.

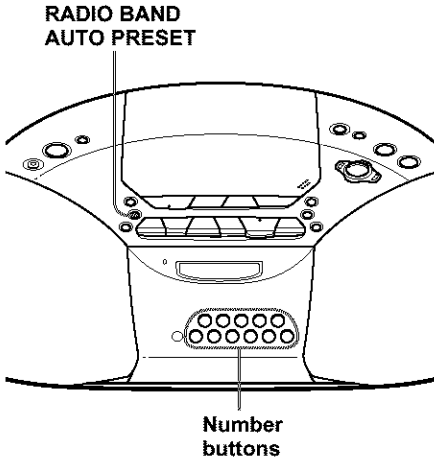

- 
- 1** Press RADIO BAND•AUTO PRESET to select the band.
- 
- 2** Press the number buttons to tune in the stored station.

To tune in a preset station over 10, press >10 first, then corresponding number buttons.

(Example: To tune in a preset station 12, press >10 and 1 first, and then press 2.)

---

## Adjusting the sound emphasis

You can adjust the audio emphasis of the sound you are listening to.

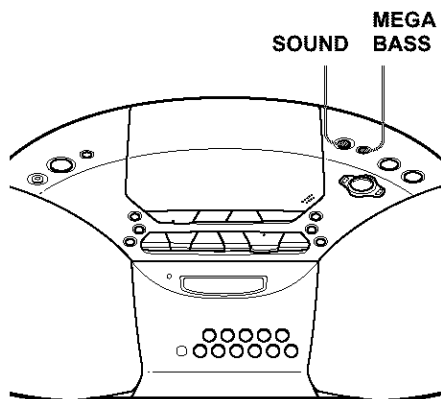

### Selecting the sound characteristic

Press SOUND repeatedly to select the audio emphasis you want.

Choose	To get
	powerful, clean sounds, emphasizing low and high range audio
	light, bright sounds emphasizing high and middle range audio
	percussive sounds, emphasizing bass audio
	the presence of vocals, stressing middle range audio
	the whole dynamic range for music such as classical music

### Reinforcing the bass sound

Press MEGA BASS to display “MEGA BASS”.

To return to normal sound, press the button again.

# Falling asleep to music

You can set the player to turn off automatically after 10, 20, 30, 60, 90 and 120 minutes, allowing you to fall asleep while listening to music.

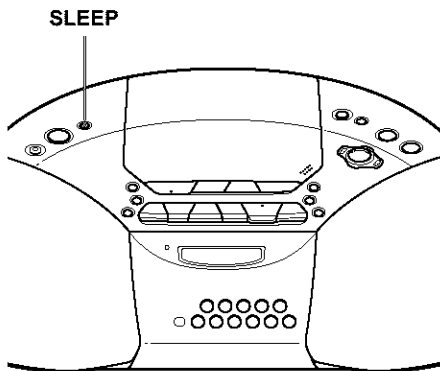

### Note

When you are playing a tape using this function: If the tape length of one side is longer than the set time, the player will not go off until the tape reaches the end.

- 1 Play the music source you want.
- 2 Press SLEEP to display "SLEEP."
- 3 Press SLEEP to select the minutes until the player goes off automatically. Each time you press the button, the indication changes as follows:  
"60" → "90" → "120" → "OFF" → "10" → "20" → "30".



If 4 seconds have passed after you pressed SLEEP, the minutes in the display are entered.

When the preset time has passed, the player goes off automatically.

### To cancel the sleep function

Press POWER to turn off the power.

## Choosing the power sources

You can use the AC power or batteries as a power source.

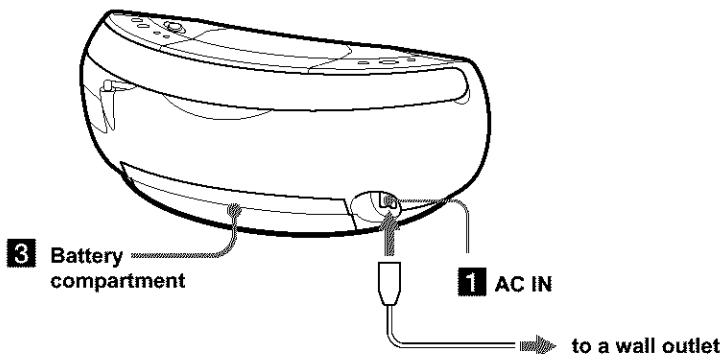

- 1** Connecting the AC power cord  
 Insert one end of the supplied AC power cord to the AC IN socket located at the rear of the player, and the other end to the wall outlet.

- 2** Preparing the remote  
 Insert two size AA (R6) batteries (not supplied).

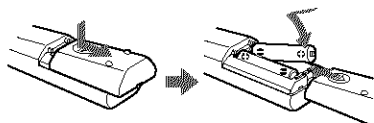

### Replacing batteries

With normal use, the batteries should last for about six months. When the remote no longer operates the player, replace all the batteries with new ones.

- 3** Using the player on batteries  
 Insert six size D (R20) batteries (not supplied) into the battery compartment. To use the player on batteries, disconnect the AC power cord from the player.

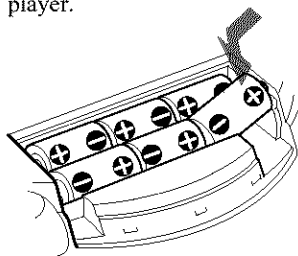

### Replacing batteries

Replace the batteries when the OPR/BATT indicator dims or when the player stops operating. Replace all the batteries with new ones.

#### Notes

- Before you replace the batteries, be sure to take out the CD from the player.
- When you operate the player with the batteries, you cannot turn on the player with the remote.

## Precautions

### On safety

- As the laser beam used in the CD player section is harmful to the eyes, do not attempt to disassemble the casing. Refer servicing to qualified personnel only.
- Should any solid object or liquid fall into the player, unplug the player, and have it checked by qualified personnel before operating it any further.
- Discs with non-standard shapes (e.g., heart, square, star) cannot be played on this player. Attempting to do so may damage the player. Do not use such discs.

### On power sources

- For AC operation, use the supplied AC power cord; do not use any other type.
- The player is not disconnected from the AC power source (mains) as long as it is connected to the wall outlet, even if the player itself has been turned off.
- Unplug the player from the wall outlet when it is not to be used for an extended period of time.
- For battery operation, use six size D (R20) batteries.
- When the batteries are not to be used, remove them to avoid damage that can be caused by battery leakage or corrosion.
- The nameplate indicating operating voltage, power consumption, etc. is located at the bottom.

### On placement

- Do not leave the player in a location near heat sources, or in a place subject to direct sunlight, excessive dust or mechanical shock.
- Do not place the player on an inclined or unstable place.
- Do not place anything within 10 mm of the side of the cabinet. The ventilation holes must be unobstructed for the player to operate properly and prolong the life of its components.

- If the player is left in a car parked in the sun, be sure to choose a location in the car where the player will not be subjected to the direct rays of the sun.
- Since a strong magnet is used for the speakers, keep personal credit cards using magnetic coding or spring-wound watches away from the player to prevent possible damage from the magnet.

### On operation

- If the player is brought directly from a cold to a warm location, or is placed in a very damp room, moisture may condense on the lens inside the CD player section. Should this occur, the player will not operate properly. In this case, remove the CD and wait about an hour for the moisture to evaporate.
- If the player has not been used for a long time, set it in the playback mode to warm it up for a few minutes before inserting a cassette.

### Notes on cassettes

- Break off the cassette tab from side A or B to prevent accidental recording. If you want to reuse the tape for recording, cover the broken tab with adhesive tape.

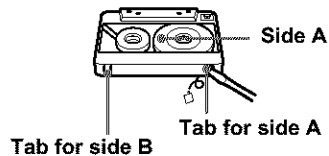

- The use of a cassette with more than 90 minutes of play time is not recommended except for long, continuous recording or playback.



## Notes on CDs

- Before playing, clean the CD with a cleaning cloth. Wipe the CD from the center out.



- Do not use solvents such as benzine, thinner, commercially available cleaners or anti-static spray intended for vinyl LPs.
- Do not expose the CD to direct sunlight or heat sources such as hot air ducts, nor leave it in a car parked in direct sunlight as there can be a considerable rise in temperature inside the car.
- Do not stick paper or sticker on the CD, nor scratch the surface of the CD.
- After playing, store the CD in its case.

If there is a scratch, dirt or fingerprints on the CD, it may cause tracking error.

## Music discs encoded with copyright protection technologies

This product is designed to play back discs that conform to the Compact Disc (CD) standard. Recently, various music discs encoded with copyright protection technologies are marketed by some record companies. Please be aware that among those discs, there are some that do not conform to the CD standard and may not be playable by this product.

If you have any questions or problems concerning your player, please consult your nearest Sony dealer.

---

# Troubleshooting

---

## General

---

### The power is not on.

- Connect the AC power cord to a wall outlet securely.
- Make sure the batteries are inserted correctly.
- You cannot turn on the player with the remote when you operate the player on batteries.

---

### The power is not on, and "BATT" and "ERROR" are displayed alternately.

- Make sure the batteries are inserted correctly.
- Replace all the batteries with new ones if they are weak.

---

### There is no audio.

- Adjust the volume.
- Unplug the headphones when listening through speakers.

---

### Noise is heard.

- Someone is using a portable telephone or other equipment that emits radio waves near the player. → Move the portable telephone, etc., away from the player.

---

## CD Player

---

### "no DISC" is displayed even when a CD is in place.

- Insert the CD with the label surface up.
- The CD-R/CD-RW is blank.
- The CD-R/CD-RW was not finalized. Finalize the CD-R/CD-RW with the recording device.
- There is a problem with the quality of the CD-R/CD-RW, recording device or application software.

---

### The CD does not play.

- Make sure that the CD compartment is closed.
- Place the CD with the label surface up.
- Clean the CD.
- Take out the CD and leave the CD compartment open for about an hour to dry moisture condensation.
- Make sure "CD" appears in the display.
- Replace all the batteries with new ones if they are weak.

---

### The sound drops out.

- Reduce the volume.
- Clean the CD, or replace it if the CD is badly damaged.
- Place the player in a location free from vibration.
- The sound may drop out or noise may be heard when using poor quality CD-Rs/CD-RWs or if there is a problem with the recording device or application software.

---

### "NOT MP3" is displayed.

- You are trying to play a file that is not an MP3 file but has extension "mp3". (page 30)

---

### "NOT MP3" and "LAYER 1", or "NOT MP3" and "LAYER 2" are displayed alternately.

- You are trying to play an MPEG1 Audio Layer-1 or 2 file. You can only play MP3 (MPEG 1 Audio Layer-3) files on this player. (page 30)

---

### "no MP3" is displayed.

- There are no MP3 files on the disc.

---

## Radio

---

### The audio is weak or has poor quality.

- Replace all the batteries with new ones if they are weak.
- Move the player away from the TV.
- If you are using the remote while listening to AM radio, noise may be heard.

---

### The picture of your TV becomes unstable.

- If you are listening to an FM program near the TV with an indoor antenna, move the player away from the TV.

## Tape Player

---

**The tape does not move when you press an operation button.**

- Close the cassette compartment securely.

**The REC ● button does not function or the tape does not play or record.**

- Make sure the safety tab on the cassette is in place.

**The tape does not erase completely.**

- Clean the erasing head (see page 28).
- Replace all the batteries with new ones if they are weak.
- The source which was recorded on TYPE II (high position) or TYPE IV (metal) tape using this unit is being played. Record on TYPE I (normal) tape and play.

**The tape does not record.**

- Make sure the tape is inserted properly.
- Make sure the safety tab of the cassette is in place.

**The audio is weak/The audio quality is poor.**

- Clean the heads, pinch roller and capstan (see page 28).
- Demagnetize the heads using a demagnetizer (see page 28).

**The sound is distorted.**

- The TYPE II (high position) or TYPE IV (metal) tape is being used. Use TYPE I (normal) tape only.

## Remote

---

**The remote does not function.**

- Replace all the batteries in the remote with new ones if they are weak.
- Make sure that you are pointing the remote at the remote sensor on the player.
- Remove any obstacles in the path of the remote and the player.
- Make sure the remote sensor is not exposed to strong light such as direct sunlight or fluorescent lamp light.
- Move closer to the player when using the remote.

After trying the above remedies, if you still have problems, unplug the AC power cord and remove all the batteries. After all the indications in the display disappear, plug the AC power cord and insert the batteries again. If the problem persists, please consult your nearest Sony dealer.

# Maintenance

## Cleaning the lens

If the lens becomes dirty, it may cause a skipping of sound during CD operation. Clean with a commercially available blower.

## Cleaning the tape heads and tape path

Wipe the heads, the pinch roller and the capstan with a cleaning swab slightly moistened with cleaning fluid or alcohol after every 10 hours of operation for optimum playback and recording quality. To make the best possible recording, however, we recommend that you clean all surfaces over which tape travels before each recording.

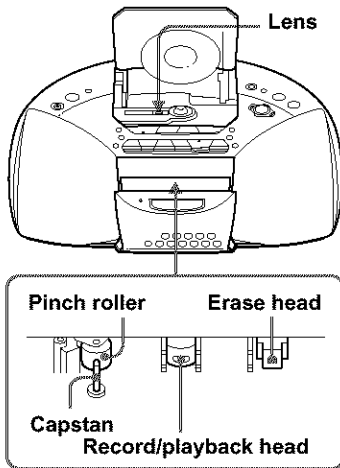

After cleaning, insert a tape when the areas cleaned are completely dry.

## Demagnetizing the tape heads

After 20 to 30 hours of use, enough residual magnetism will have built up on the tape heads to begin to cause loss of high frequency sound and hiss. At this time, you should demagnetize the heads and all metal parts in the tape path with a commercially available tape head demagnetizer.

## Cleaning the cabinet

Clean the cabinet, panel and controls with a soft cloth slightly moistened with a mild detergent solution. Do not use any type of abrasive pad, scouring powder, or solvent, such as alcohol or benzene.

# Specifications

## AUDIO POWER SPECIFICATIONS

### POWER OUTPUT AND TOTAL HARMONIC DISTORTION

With 3.2-ohm loads, both channels driven from 150 - 6,300 Hz; rated 1.8 W per channel-minimum RMS power, with no more than 10 % total harmonic distortion in AC operation.

## Other Specifications

### CD player section

#### System

Compact disc digital audio system

#### Laser diode properties

Material: GaAlAs

Wave length: 780 nm

Emission duration: Continuous

Laser output: Less than 44.6  $\mu$ W

(This output is the value measured at a distance of about 200 mm from the objective lens surface on the optical pick-up block with 7 mm aperture.)

#### Spindle speed

200 r/min (rpm) to 500 r/min (rpm) (CLV)

#### Number of channels

2

#### Frequency response

20 - 20 000 Hz  $\pm$ 1/-2 dB

#### Wow and flutter

Below measurable limit

### Radio section

#### Frequency range

FM: 87.5 - 108 MHz

AM: 531 - 1 611 kHz (Taiwan model)  
530 - 1 710 kHz (Other models)

#### Antennas

FM: Telescopic antenna

AM: Built-in ferrite bar antenna

### Cassette-corder section

#### Recording system

4-track 2 channel stereo

#### Fast winding time

Approx. 120 s (sec.) with Sony cassette C-60

#### Frequency response

TYPE I (normal): 80 - 10 000 Hz

### General

#### Speaker

Full range: 10 cm (4 in.) dia.,

3.2  $\Omega$ , cone type (2)

#### Outputs

Headphones jack (stereo minijack)

For 16 - 68  $\Omega$  impedance headphones

#### Power output

2.3 W  $\pm$  2.3 W (at 3.2  $\Omega$ , 10 % harmonic distortion)

#### Power requirements

For CD radio cassette-corder:

120 AC, 60 Hz

9 V DC, 6 size D (R20) batteries

For remote control:

3 V DC, 2 size AA (R6) batteries

#### Power consumption

AC 20 W

#### Battery life

For CD radio cassette-corder:

---

#### FM recording

---

Sony R20P: approx. 13.5 h

Sony alkaline LR20: approx. 20 h

---

#### Tape playback

---

Sony R20P: approx. 7.5 h

Sony alkaline LR20: approx. 15 h

---

#### CD playback

---

Sony R20P: approx. 2.5 h

Sony alkaline LR20: approx. 7 h

#### Dimensions

Approx. 386  $\times$  166  $\times$  252 mm (w/h/d)

(15  $\frac{1}{4}$   $\times$  6  $\frac{5}{8}$   $\times$  10 inches)(incl. projecting parts)

#### Mass

Approx. 3.3 kg (7 lb. 4 oz) (incl. batteries)

#### Supplied accessories

AC power cord (1)

Remote control (1)

Design and specifications are subject to change without notice.

### Optional accessories

Sony MDR headphones series

## About "MP3"

### What is the MP3?

MP3 (MPEG 1 Audio Layer-3) is a standard technology and format for compressing a sound sequence. The file is compressed to about 1/10 of its original size. Sounds outside the range of human hearing are compressed while the sounds we can hear are not compressed.

### Playable "MP3" files on this player

You can only play MP3 files recorded by following requirements.

#### USABLE MEDIA

CD-Rs and CD-RWs

#### USABLE DISC FORMAT

You can use ISO 9660 Level 1, Level 2 and Joliet extension format discs. In some cases, MP3 files that are recorded in a format other than these formats may not play normally or the file and folder names may not be displayed correctly.

The major specifications of the usable disc format are as follows:

- Maximum directory steps: 8
- Usable characters for a file/folder name: A - Z, a - z, 0 - 9, \_ (underscore)
- Maximum number of characters for a file name: 64 including quotation marks and a 3-character extension code

#### Notes

- When naming, be sure to add the file extension "mp3" to the file name.
- If you put the extension "mp3" to a file other than an MP3 file, the player cannot recognize the file properly and will generate random noise that could damage your speakers.
- The file name does not correspond to the ID tag.

#### THE USABLE NUMBER OF FOLDERS/FILES

- Maximum folder number: 255
- Maximum file number: 255

#### SETTINGS FOR COMPRESSION SOFTWARE AND WRITING SOFTWARE

- To compress a source for an MP3 file, we recommend setting the transfer bit rate of the compression software to "44.1 kHz", "128kbps", and "Constant Bit Rate".
- To record up to the maximum capacity, set to the "halting of writing".
- To record at one time up to the maximum capacity on media that has nothing recorded it, set to "Disc at Once".

#### NOTES FOR SAVING FILES ON THE MEDIA

When the disc is inserted, the player reads all the files on that disc. If there are many folders or non-MP3 files on the disc, it may take a long time for play to begin or for the next MP3 file to start play.

Do not save unnecessary folders or files other than MP3 ones in the disc to be used for MP3 listening.

We recommend that you do not save other types files or unnecessary folders on a disc that has MP3 files.

### About "ID3 tag"

ID3 tag is a format for adding certain information (song title, artist name, album name, etc.) to MP3 files.

This player conforms to Version 1.1 of the ID3 tag format. If the file has the ID3 tag information, "song title", "artist name" and "album name" can be displayed.

#### Note

If you use a version other than 1.1, ID3 tag information will not be displayed correctly.

# Index

## A

Audio emphasis 21

## B

Batteries

for player 23

for remote 23

## C

CD player 4

Choosing power sources 23

Cleaning

cabinet 28

lens 28

tape heads and tape path  
28

Connecting AC power cord 23

Creating your own program 17

## D, E, F, G, H

Demagnetizing the tape heads  
28

Display 14

## I, J, K

ID3 tag 14, 30

Improving broadcast reception  
9

## L

Listening to the radio 8

Locating a specific track 15

## M, N, O

Maintenance 28

MEGA BASS 21

MP3

about MP3 30

display 14

playing order 7

## P, Q

Playing

a CD 4

a tape 10

preset radio stations 19

tracks in random order 17

tracks repeatedly 16

Power sources 23

Precautions 24

Presetting radio stations 19

Program Play 17

## R

Radio stations

playing 20

presetting 19

Repeat Play 16

## S

Selecting

audio emphasis 21

tracks 5

Setting up 23

Shuffle Play 17

SOUND 21

Specifications 29

## T

Timer

falling asleep to music 22

Troubleshooting 26

## U, V, W, X, Y, Z

Using the display 14

**For customers in the USA**

Please register this product on line at <http://www.sony.com/productregistration>.

Proper registration will enable us to send you periodic mailings about new products, services and other important announcements. Registering your product will also allow us to contact you in the unlikely event that the product needs adjustment or modification. Thank you.