

SONY.

3-081-835-11(1)

Digital Still Camera

Operating Instructions

Before operating the unit, please read this manual thoroughly, and retain it for future reference

Owner's Record

The model and serial numbers are located on the bottom. Record the serial number in the space provided below. Refer to these numbers whenever you call upon your Sony dealer regarding this product.

Model No. MVC-CD350

Serial No. _____

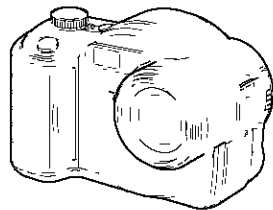

MVC-CD350

CD Mavica



Getting started _____

Shooting still images _____

Viewing still images _____

Deleting still images _____

Before advanced operations _____

Advanced still image shooting _____

Advanced still image viewing _____

Still image editing _____

Enjoying movies _____

Enjoying images on your computer _____

Troubleshooting _____

Additional information _____

Index _____

WARNING

To prevent fire or shock hazard, do not expose the unit to rain or moisture.

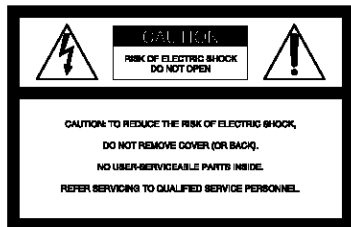

This symbol is intended to alert the user to the presence of uninsulated "dangerous voltage" within the product's enclosure that may be of sufficient magnitude to constitute a risk of electric shock to persons.



This symbol is intended to alert the user to the presence of important operating and maintenance (servicing) instructions in the literature accompanying the appliance.

CAUTION

The use of optical instruments with this product will increase eye hazard. Use of controls or adjustments or performance of procedures other than those specified herein may result in hazardous radiation exposure.

If you have any questions about this product, you may call:

Sony Customer Information Center
1-800-222-SONY (7669)

The number below is for the FCC related matters only.

Regulatory Information

Declaration of Conformity

Trade Name: SONY
Model No.: MVC-CD350
Responsible Party: Sony Electronics Inc.
Address: 680 Kinderkamack Road,
Oradell, NJ 07649 USA
Telephone No.: 201-930-6972

This device complies with Part 15 of the FCC Rules. Operation is subject to the following two conditions: (1) This device may not cause harmful interference, and (2) this device must accept any interference received, including interference that may cause undesired operation.

CAUTION

You are cautioned that any changes or modifications not expressly approved in this manual could void your authority to operate this equipment.

Note:

This equipment has been tested and found to comply with the limits for a Class B digital device, pursuant to Part 15 of the FCC Rules. These limits are designed to provide reasonable protection against harmful interference in a residential installation. This equipment generates, uses, and can radiate radio frequency energy and, if not installed and used in accordance with the instructions, may cause harmful interference to radio communications. However, there is no guarantee that interference will not occur in a particular installation. If this equipment does cause harmful interference to radio or television reception, which can be determined by turning the equipment off and on, the user is encouraged to try to correct the interference by one or more of the following measures:

- Reorient or relocate the receiving antenna.
- Increase the separation between the equipment and receiver.
- Connect the equipment into an outlet on a circuit different from that to which the receiver is connected.
- Consult the dealer or an experienced radio/TV technician for help.

The shielded interface cable recommended in this manual must be used with the equipment in order to comply with the limits for a digital device pursuant to Subpart B of Part 15 of FCC Rules.

RECYCLING LITHIUM-ION BATTERIES

Lithium-Ion batteries are recyclable.

You can help preserve our environment by returning your used rechargeable batteries to the collection and recycling location nearest you.



For more information regarding recycling of rechargeable batteries, call toll free 1-800-822-8837, or visit <http://www.rbrc.org/>

Caution: Do not handle damaged or leaking Lithium-Ion batteries.

CAUTION

TO PREVENT ELECTRIC SHOCK, DO NOT USE THIS POLARIZED AC PLUG WITH AN EXTENSION CORD, RECEPTACLE OR OTHER OUTLET UNLESS THE BLADES CAN BE FULLY INSERTED TO PREVENT BLADE EXPOSURE.

Before using your camera

This digital still camera uses 8 cm CD-Rs/CD-RWs as recording media. "CD-R" or "CD-RW" mentioned above is indicated as "disc" in this manual. When a distinction between CD-Rs and CD-RWs is necessary, "disc" is indicated as "CD-R" or "CD-RW."

Refer to page 18 for discs that can be used with this camera, and page 108 for precautions on handling discs.

- We recommend that you use this camera with Mavica discs*.
- While the image is being read from or written to the disc, the ACCESS lamp flashes (red). When this lamp is lit, do not shake or strike the camera.

* The Mavica disc is an 8 cm CD-R/CD-RW with the Mavica logo.

Trial recording

Before you record one-time events, you may want to make a trial recording to make sure that the camera is working correctly.

No compensation for contents of the recording

Contents of the recording cannot be compensated for if recording or playback is not possible due to a malfunction of your camera or recording media, etc.

Back up recommendation

To avoid the potential risk of data loss, always copy (back up) data to a disk.

Notes on image data compatibility

- This camera conforms with the Design rule for Camera File system universal standard established by the JEITA (Japan Electronics and Information Technology Industries Association).
- Playback of images recorded with your camera on other equipment and playback of images recorded or edited with other equipment on your camera are not guaranteed.

Precaution on copyright

Television programs, films, video tapes, and other materials may be copyrighted. Unauthorized recording of such materials may be contrary to the provision of the copyright laws.

Do not shake or strike the camera

In addition to malfunctions and inability to record images, this may render the discs unusable or image data breakdown, damage or loss may occur.

LCD screen, LCD finder (only models with an LCD finder) and lens

- The LCD screen and the LCD finder are manufactured using extremely high-precision technology so over 99.99% of the pixels are operational for effective use. However, there may be some tiny black points and/or bright points (white, red, blue or green in color) that constantly appear on the LCD screen and the LCD finder. These points are normal in the manufacturing process and do not affect the recording in any way.
- Be careful when placing the camera near a window or outdoors. Exposing the LCD screen, the finder or the lens to direct sunlight for long periods may cause malfunctions.
- Do not press the LCD screen hardily. The screen may be uneven and that may cause a malfunction.
- Images may be trailed on the LCD screen in a cold location. This is not a malfunction.

Clean the flash surface before use

The heat of flash emission may cause dirt on the flash surface to become discolored or to stick to the flash surface, resulting in insufficient light emission.

Do not get the camera wet

When taking pictures outdoors in the rain or under similar conditions, be careful not to get the camera wet. If moisture condensation occurs, see page 108 and follow the instructions on how to remove it before using the camera.

Do not expose the camera to sand or dust

Using the camera in sandy or dusty locations may cause malfunction.

Do not aim the camera at the sun or other bright light

This may cause irrecoverable damage to your eyes. Or it may cause the malfunction of your camera.

Notes on the camera locations

- Do not use the camera near a location that generates strong radio wave or emits radiation. The camera may not be able to record or play back properly.
- Do not use the camera near a TV, radio, tuner. Noise may be caused on the camera.

The pictures used in this manual

The photographs used as examples of pictures in this manual are reproduced images, and are not actual images shot using this camera.

Trademarks

- “InfoLITHIUM” is a trademark of Sony Corporation.
- Microsoft and Windows are registered trademarks of the U.S. Microsoft Corporation in the United States and other countries.
- Macintosh and Mac OS are trademarks or registered trademarks of Apple Computer, Inc.
- Pentium is a trademark or a registered trademark of Intel Corporation.
- In addition, system and product names used in this manual are, in general, trademarks or registered trademarks of their respective developers or manufacturers. However, the TM or ® marks are not used in all cases in this manual.

Table of contents

Before using your camera	4
Introduction.....	8
Identifying the parts	9

Getting started

Charging the battery pack	11
Using an external power source.....	14
Using your camera abroad.....	14
Turning on/off your camera.....	15
How to use the control button.....	15
Setting the date and time.....	16

Shooting still images

Inserting and removing a disc	18
Initializing a disc.....	19
What is initialization?.....	19
Setting the still image size	20
Image size and quality	21
Basic still image shooting	
— Auto adjustment mode.....	22
Checking the last image you shot	
— Quick Review	24
Using the zoom feature.....	24
Shooting close-ups — Macro	25
Using the self-timer	26
Selecting a flash mode.....	27
Indicators on the screen during	
shooting	29
Inserting the date and time on a still	
image	30

Viewing still images

Viewing images on the LCD screen of your camera.....	31
Viewing images on a TV screen.....	33

Deleting still images

Deleting images.....	35
Formatting a CD-RW	38

Before advanced operations

How to setup and operate your camera ..	40
Changing the menu settings	40
Changing the items in the SET UP	
screen	40
Deciding the still image quality.....	41
Creating or selecting a folder	41
Creating a new folder.....	42
Changing the recording folder	42

Advanced still image shooting

Choosing an auto focus method	43
Choosing a focus range finder frame	
— AF range finder.....	43
Choosing a focus operation	
— AF Mode	44
Setting the distance to the subject	
— Focus preset	46

Adjusting the exposure	
— EV adjustment	46
Selecting the metering mode.....	47
Adjusting color tones	
— White Balance	48
Adjusting the flash level	
— Flash Level	49
Shooting multiple frames	
— Clip Motion	50
Shooting in Multi Burst mode	
— Multi Burst.....	51
Shooting two images continuously	
— Burst 2	52
Shooting still images in TIFF mode	
— TIFF	53
Shooting still images for e-mail	
— E-Mail.....	53
Shooting still images with audio files	
— Voice.....	54
Shooting according to scene conditions	
— Scene Selection.....	55
Adding special effects	
— Picture Effect	57
Confirming whether to record images	
— Confirm before write	57

Advanced still image viewing

Selecting the folder and playing back images	
— Folder	59
Enlarging a portion of a still image	60
Enlarging an image	
— Playback zoom	60
Recording an enlarged image	
— Trimming	61
Playing back successive images	
— Slide Show	61
Rotating still images	
— Rotate	62
Playing back images shot in Multi Burst mode	63
Playing back continuously	63
Playing back frame by frame	
— Jog playback	63

Still image editing

Protecting images	
— Protect	65
Changing image size	
— Resize	67
Choosing images to print	
— Print (DPOF) mark	67

Enjoying movies

Shooting movies	70
Viewing movies on the LCD screen	71
Deleting movies — Delete	72

Enjoying images on your computer

Viewing images on your computer	
— Introduction	74
Viewing images using CD-ROM drive	75
Finalizing a disc	75
What is finalization?	75
Canceling finalization (Unfinalize) (CD-RW only)	76
Using the supplied 8cm CD adapter	77
Viewing images through a CD-ROM drive	78
Image file storage destinations and image file names	79
Copying images into your computer	
through a USB connection	81
Installing the PTP Manager	81
Installing “ImageMixer”	83
Connecting the camera to your computer	83
Copying images	85
When the PTP Manager does not start up	86

Copying images using the Windows XP AutoPlay Wizard	86
Viewing images on your computer	87
Creating a Video CD	87
For Mac OS X (v10.0/v10.1/v10.2) users	87

Troubleshooting

Troubleshooting	88
Warnings and messages	96
Self-diagnosis display	98

Additional information

Number of images that can be saved or shooting time	99
Menu items	101
SET UP items	105
Precautions	107
On discs	108
On “InfoLITHIUM” battery pack	109
Specifications	111
The LCD screen	113

Index

Index	116
-------	-----

Introduction

This digital still camera is capable of recording still images and movies onto 8 cm CD-R/CD-RW discs.

Capture images with your computer

You can easily copy images onto your computer through a CD-ROM drive or the USB cable, and view and modify images on your computer using application software. When using a CD-ROM drive to view images on your computer, finalization is required (page 75).

Flow chart for disc operations

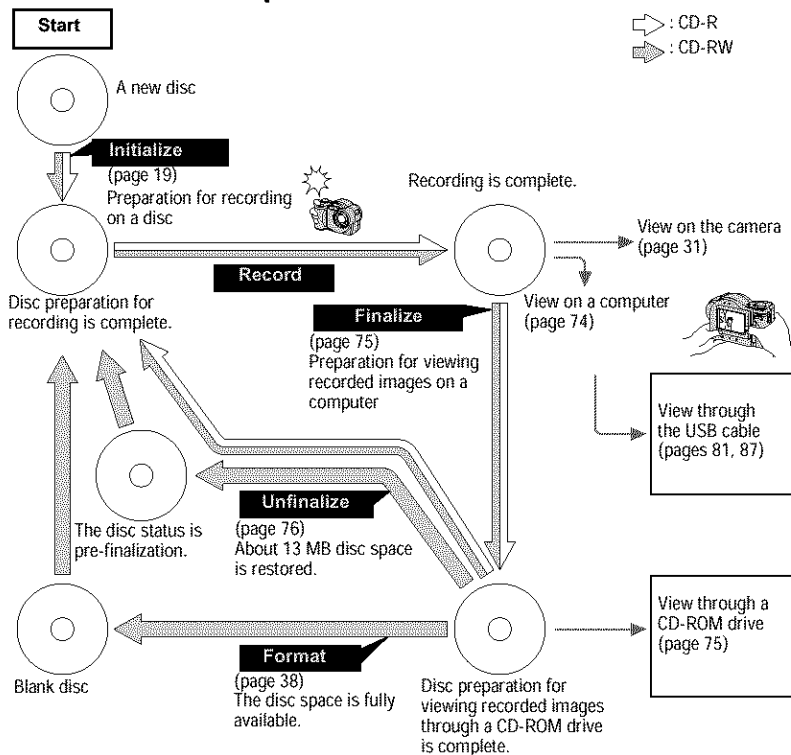

Identifying the parts

See the pages in parentheses for details of operation.

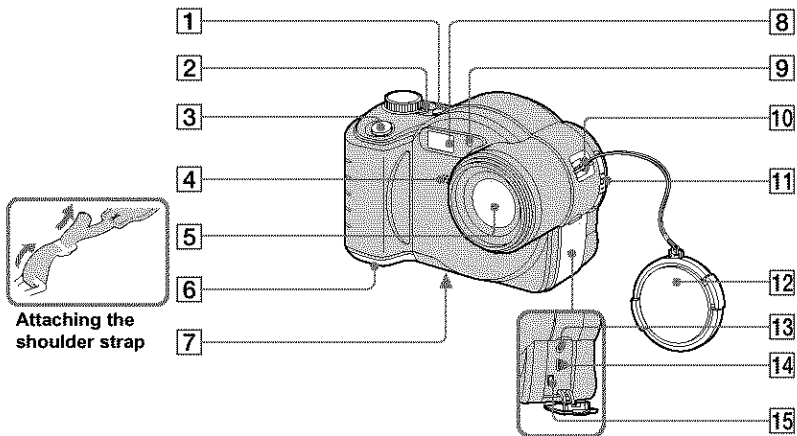







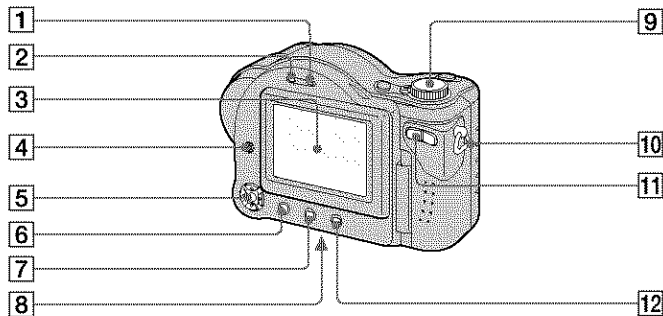



- 1 POWER button (15)
- 2 POWER lamp (15)
- 3 Shutter button (22)
- 4 Microphone
- 5 Lens
- 6 Battery cover (11)
- 7 Tripod receptacle (bottom surface)
- 8 Flash emitter (27)
- 9 Self-timer lamp (26)/
AF illuminator (28, 105)





- 10 Hook for lens cap/shoulder strap
- 11 Disc cover OPEN lever (18)
- 12 Lens cap
- 13 A/V OUT (MONO) jack (33)
- 14 USB jack (84)
- 15 DC IN jack (11, 14)

- Use a tripod with a screw length of less than 5.5 mm (7/32 inch). You will be unable to firmly secure the camera to tripods having longer screws, and may damage the camera.
- Do not touch the microphone while recording.
- The “3.2 MEGA PIXELS” indicated on the camera shows the number of effective pixels. The number of actually recorded pixels is maximum 3.1 MEGA PIXELS. The effective pixels number is determined according to the recommendation of the JCIA (Japan Camera Industry Association).



- 10 Hook for shoulder strap
- 11 Zoom button (for shooting) (24)/
Index button (for viewing) (32)
- 12  /  (Image Size/Delete)
button (20, 35)

- 1 ACCESS lamp (18)
- 2  /CHG (charge) lamp (12)
- 3 LCD screen
- 4 Speaker
- 5 Control button
(Menu on) (////●)
(Menu off) (////●) (27, 26,
24, 25)
- 6 MENU button (40, 101)
- 7 DISPLAY ON/OFF button (29)
- 8 RESET button (bottom surface)
(88)

- 9 Mode dial (16)
 - : To shoot still images in auto
adjustment mode
 - P: To shoot still images in
programmed mode
 - SCN: To shoot in the Scene
Selection mode
 - SET UP: To set the SET UP items
 - : To shoot movies, Clip
Motion images or Multi
Burst mode images
 - : To view or edit images

Charging the battery pack

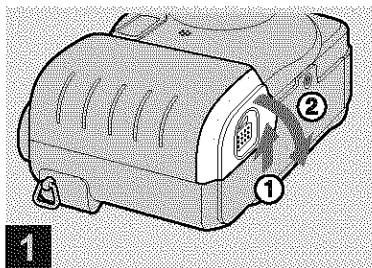

➔ Open the battery cover.

Slide the cover in the direction of the arrow.

- **Be sure to turn off your camera when charging the battery pack (page 15).**
- Your camera operates only with the "InfoLITHIUM" NP-FM50 battery pack (M series) (supplied) (page 109).

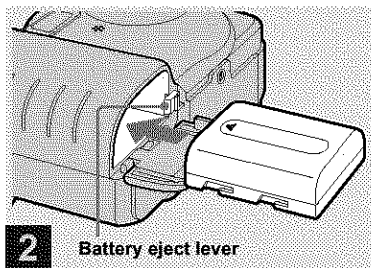

➔ Install the battery pack, then close the battery cover.

Insert the battery pack with the ◀ mark facing toward the battery compartment as illustrated.

Make sure the battery pack is firmly inserted all the way, then close the cover.

- The battery pack is easily inserted by pushing the battery eject lever at the front of the battery compartment up.

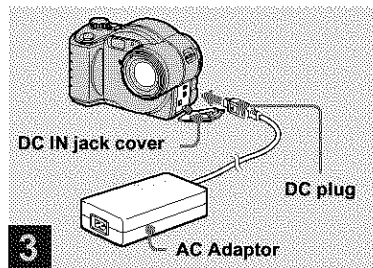

➔ Open the DC IN jack cover and connect the AC Adaptor (supplied) to the DC IN jack of your camera.

Connect the DC plug with the ▲ mark facing forward.

- Do not short the DC plug of the AC Adaptor with a metallic object, as this may cause malfunction.
- Clean the DC plug of the AC Adaptor with a dry cotton bud. Do not use the dirty plug. Use of the dirty plug may not properly charge the battery pack.

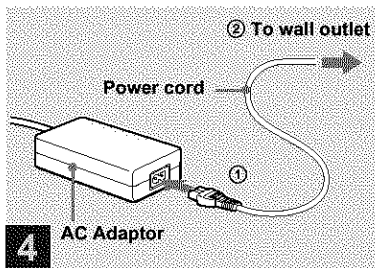

➔ **Connect the power cord to the AC Adaptor and then to a wall outlet.**

The ⚡/CHG lamp (orange) lights up when charging begins, and goes off when charging is completed.

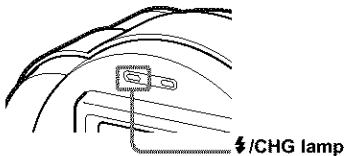

- After charging the battery pack, disconnect the AC Adaptor from the DC IN jack of your camera.

To remove the battery pack

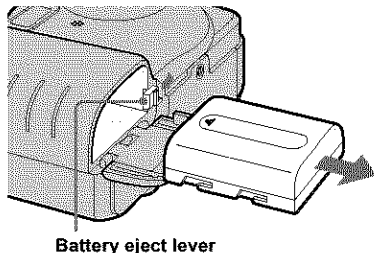

Open the battery cover. Slide the battery eject lever in the direction of the arrow, and remove the battery pack.

- Be careful not to drop the battery pack when removing it.

Battery remaining indicator

The battery remaining indicator on the LCD screen shows the remaining shooting or viewing time.

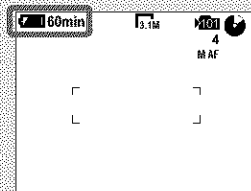

- The black portion of the battery remaining indicator in the illustration shows the actual remaining time.
- The displayed remaining time may not be correct under certain circumstances or conditions.

Charging time

Approximate time to charge a completely discharged battery pack using the AC Adaptor at a temperature of 25°C (77°F).

Battery pack	Charging time (min.)
NP-FM50 (supplied)	Approx. 150

Number of images and battery life that can be recorded/ viewed

The tables show the approximate number of images and the battery life that can be recorded/viewed when you shoot images in normal mode with a fully charged battery pack at a temperature of 25°C (77°F). The numbers of images that can be recorded or viewed take into account changing the supplied disc as necessary. Note that the actual numbers may be less than indicated depending on the conditions of use.

Shooting still images

Under the average conditions¹⁾

Image size	NP-FM50 (supplied)	
	No. of images	Battery life (min.)
3.1M	Approx. 270	Approx. 135
VGA	Approx. 290	Approx. 145

1) Shooting in the following situations:

- [P. Quality] is set to [Fine]
- Shooting one time every 30 seconds
- The zoom is switched alternately between the W and T ends
- The flash strobes once every two times
- The power turns on and off once every ten times
- [AF Mode] is set to [Monitor] in the SET UP settings

Viewing still images²⁾

Image size	NP-FM50 (supplied)	
	No. of images	Battery life (min.)
3.1M	Approx. 1900	Approx. 160
VGA	Approx. 2000	Approx. 170

2) Viewing single images in order at about five second intervals

Shooting movies³⁾

	NP-FM50 (supplied)
	Battery life (min.)
Continuous shooting	Approx. 150

3) Shooting continuously at 160 (Mail) image size

- The number of images and the battery life that can be recorded/viewed are decreased under the following conditions:
 - The surrounding temperature is low
 - The flash is used
 - The camera has been turned on and off many times
 - The zoom is used frequently
 - [LCD Backlight] is set to [Bright] in the SET UP settings
 - The battery power is low.
- The battery capacity decreases as you use it more and more and as time passes (page 110).
- [AF Mode] is set to [Cont] in the SET UP settings

Using an external power source

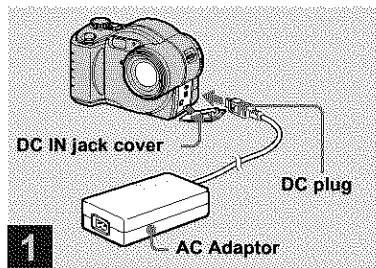

- ➔ Open the DC IN jack cover and connect the AC Adaptor (supplied) to the DC IN jack of your camera.

Connect the DC plug with the ▲ mark facing forward.

- Connect the AC Adaptor to an easily accessible wall outlet close by. If any trouble occurs while using the adaptor, immediately shut off the power by disconnecting the plug from the wall outlet.

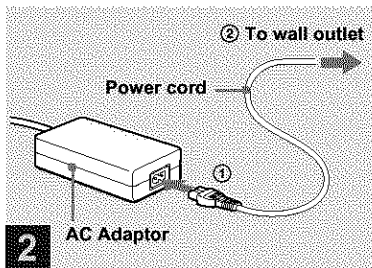

- ➔ Connect the power cord to the AC Adaptor and then to a wall outlet.

- When you have finished using the AC Adaptor, disconnect it from the DC IN jack of the camera.
- The set is not disconnected from the AC power source as long as it is connected to the wall outlet, even if the unit itself has been turned off.

Using your camera abroad

Power sources

You can use your camera in any country or region with the supplied AC Adaptor within 100 V to 240 V AC, 50/60 Hz. Use a commercially available AC plug adaptor [a], if necessary, depending on the design of the wall outlet [b].

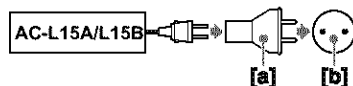

- Do not use an electronic transformer (travel converter), as this may cause a malfunction.

Turning on/off your camera

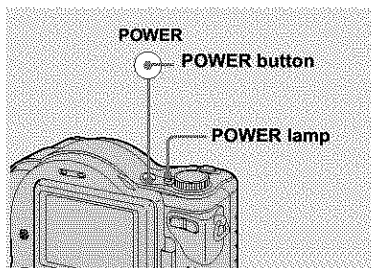

→ Press POWER.

The POWER lamp (green) lights up and the power is on. When you turn on your camera for the first time, the Clock Set screen appears (page 16).

Turning off the power

Press POWER again. The POWER lamp goes out, and the camera turns off.

Auto power-off function







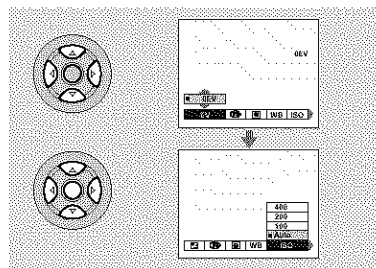

If you do not operate the camera for about three minutes during shooting or viewing or when performing SET UP, the camera turns off automatically to prevent wearing down the battery. The auto power-off function only operates when the camera is operating using a battery pack. The auto power-off function also will not operate in the following circumstances.

- When viewing movies
- When a connector is plugged into the  (USB) jack or the A/V OUT (MONO) jack.

How to use the control button





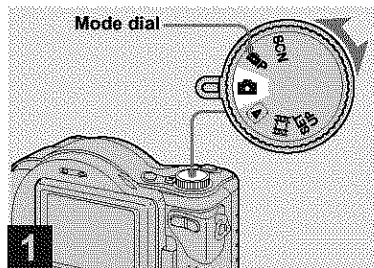

To change the current settings of the camera, bring up the menu or the SET UP screen (page 40), and use the control button to make the changes.

For each item, press /// to select the desired value, then press the center  or /// to make the setting.

Setting the date and time



→ Set the mode dial to .

- You can also carry out this operation when the mode dial is set to , SCN,  or .
- To change the date and time, set the mode dial to SET UP, select [Clock Set] in  (Setup 1) (page 106), and perform the procedure from step **3**.

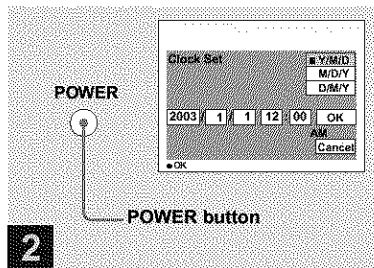

→ Press **POWER** to turn on the power.

The **POWER** lamp (green) lights up and the Clock Set screen appears on the LCD screen.

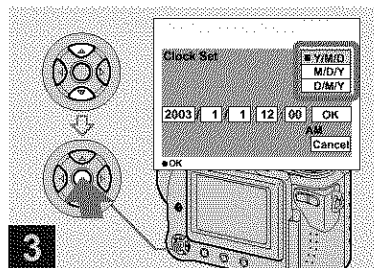

→ Select the desired date display format with **▲/▼** on the control button, then press **●**.

Select from [Y/M/D] (year/month/day), [M/D/Y] (month/day/year) or [D/M/Y] (day/month/year).

- If the rechargeable button battery, which provides the power for saving the time data, is ever fully discharged (page 108), the Clock Set screen will appear again. When this happens, reset the date and time, by starting from step **3** above.

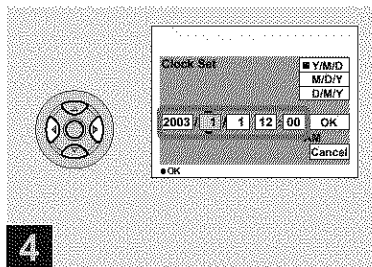

- 4** → Select the year, month, day, hour or minute item you want to set with ◀/▶ on the control button.

The item to be set is indicated with ▲/▼.

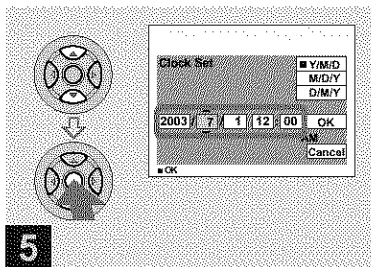

- 5** → Set the numeric value with ▲/▼ on the control button, then press ● to enter it.

After entering the number, ▲/▼ moves to the next item. Repeat this step until all of the items are set.

- If you selected [D/M/Y] in step **3**, set the time on a 24-hour cycle.

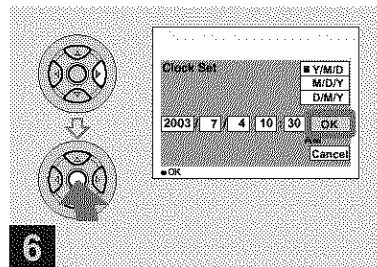

- 6** → Select [OK] with ▶ on the control button, then press ●.

The date and time are entered and the clock starts to keep time.

- To cancel the date and time setting, select [Cancel] with ▲/▼/◀/▶ on the control button, then press ●.

Inserting and removing a disc

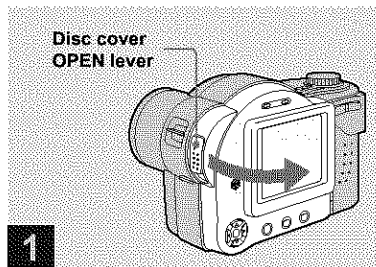

1

→ Open the disc cover.

Slide down the disc cover OPEN lever, and open the disc cover.

- You can use only 8 cm CD-R/CD-RW discs that have these marks.



- For details on disc, see page 108.

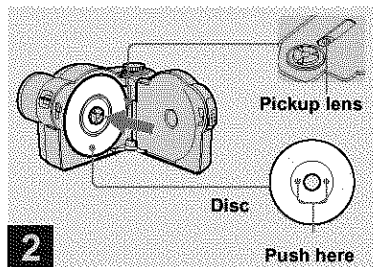

2

→ Place a disc in the disc tray.

Place the disc with the printed side up, and push down on the center of the disc until it clicks.

- Do not forcibly push on the disc.
- Do not touch the pickup lens.

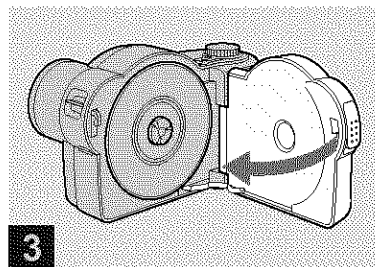

3

→ Close the disc cover.

Removing the disc

Open the disc cover. Check to make sure that the disc has completely stopped rotating, then remove the disc.

- When the **ACCESS** lamp is flashing, it means that image data is being read or written. Never open the disc cover or turn off the power at this time, as the image data may be damaged or the disc may become unusable.
- While the camera is writing data on a disc, the disc cover OPEN lever is locked.
- After you change the disc, "Repairing Data" may appear on the LCD screen and it may take about 10 minutes to prepare the disc for recording depending on the disc condition.

Initializing a disc

What is initialization?

Initialization is required to record images on a disc.

When you perform finalization (page 75) using your camera to view images through a CD-ROM drive, initialization is also automatically performed, and you can continue to record images. Images recorded before finalization remain on the disc.

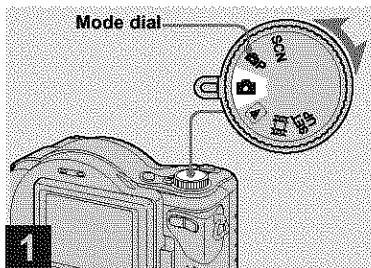

➔ Insert a new disc and set the mode dial to **P**, then turn on the power.

“Initialize Place on level surface” appears on the LCD screen.

To cancel initialization

Select [Cancel] with **▼** on the control button, then press **●**. After canceling the initialization, open and close the disc cover, then perform the procedure from step **1**.

- You can also carry out this operation when the mode dial is set to **P**, **SCN** or **□**.
- You can also perform initialization using **Ⓜ** (Disc Tool 1) in the SET UP settings (page 105).

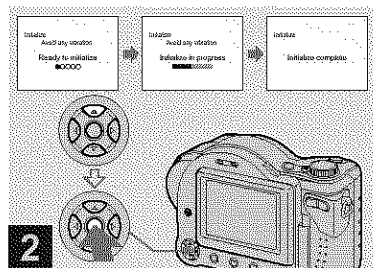



➔ Select **[OK]** with **▲** on the control button, then press **●**.

Initialization starts. Do not shake or strike the camera during initialization.

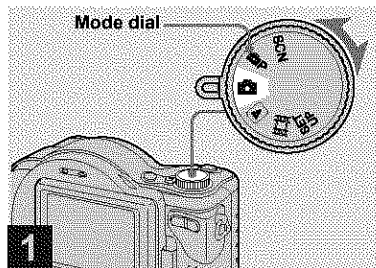
Setting the still image size



➔ Set the mode dial to  and turn on the power.

- You can also carry out this operation when the mode dial is set to  or SCN.

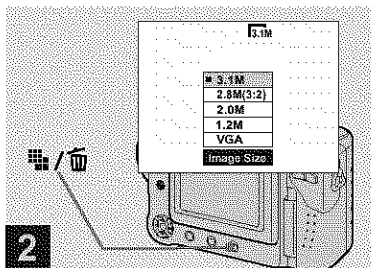



➔ Press  /  (Image Size).

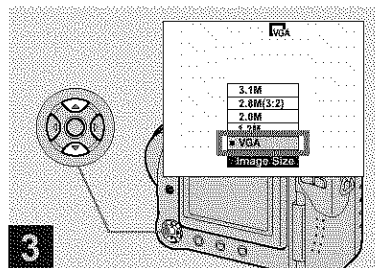

The Image Size setup appears.

- For details on the image size, see page 21.



➔ Select the desired image size with  /  on the control button.

The image size is set.

When the setting is complete, press  /  (Image Size) so that the Image Size setup disappears from the LCD screen.

- The image size selected here is maintained even when the power is turned off.

Image size and quality

You can choose image size (number of pixels) and image quality (compression ratio) based on the kind of images you want to shoot. The larger you make the image size and the higher you make the image quality, the better your image, but also the larger the amount of data needed to preserve your image. This means you can save fewer images in your disc.

Choose an image size and quality level appropriately for the kind of images you want to shoot.

You can resize the images later (Resize function, see page 67).

You can choose image size from among the five options in the following tables. The below image size is a minimum setting for examples. When you want to improve image quality, select the larger image size.

Image size		Examples
3.1M	2048×1536	Printing A4 size images
2.8M(3:2)	2048 (3:2)	3:2 prints ¹⁾
2.0M	1632×1224	Printing A5 size images
1.2M	1280×960	Printing postcard size images
VGA	640×480	Creating home pages

¹⁾ This option records images in a horizontal to vertical proportion of 3:2 to match the size of the print paper used.

The number of images that can be saved in a supplied CD-R²⁾

(Units: images)

Quality ³⁾ \ Image size	Fine	Standard
	3.1M	81
2.8M(3:2)	81	145
2.0M	131	234
1.2M	194	345
VGA	655	1285

²⁾ When [REC Mode] is set to [Normal]

For the number of images that can be saved in other modes, see page 99.

³⁾ For more information about the image quality mode, see page 41.

- The "3.2 MEGA PIXELS" indicated on the camera shows the number of effective pixels. The number of actually recorded pixels is maximum 3.1 MEGA pixels.
- When images recorded using earlier Sony models are played back on this camera, the display may differ from the actual image size.
- When the images are viewed on the LCD screen of the camera, they all look the same size.
- Number of shooting images can differ from these values according to shooting conditions.
- When the number of remaining shooting images is greater than 9999, the >9999 indicator appears on the LCD screen.

Basic still image shooting – Auto adjustment mode

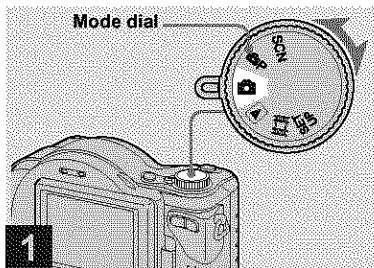

➔ Set the mode dial to **A**, and turn on the power.

The name of the folder where the image will be recorded appears on the LCD screen for approximately five seconds.

- This camera can create new folders and select folders to be stored in the disc (page 41).

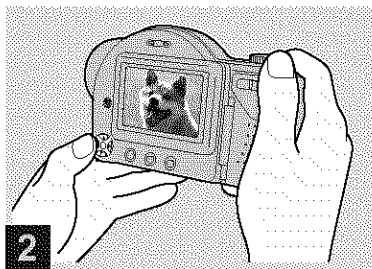

➔ Hold the camera steadily with both hands and position the subject in the center of the focus frame.

Do not cover the lens or flash with your fingers.

- The minimum focal distance to the subject is 50 cm (19 3/4 inches) at the W end and 80 cm (31 1/2 inches) at the T end. To shoot even closer subjects, use macro recording mode (page 25).

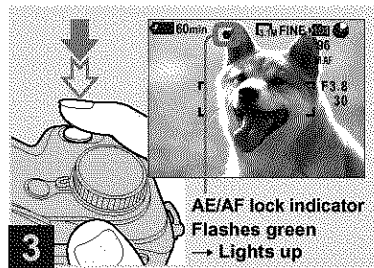

➔ Press and hold the shutter button halfway down.

The beep sounds. When the AE/AF lock indicator changes from flashing to steadily lit, the camera is ready for shooting. (The LCD screen may be frozen for a split second depending on the subject.)

- If you release the shutter button, the recording will be canceled.
- When the camera does not beep, the AF adjustment is not complete. You can continue to shoot, but the AF is not set properly (except in Continuous AF).
- The frame appearing on the LCD screen shows the focus adjustment range. (For more details on the AF range finder frame, see page 43.)

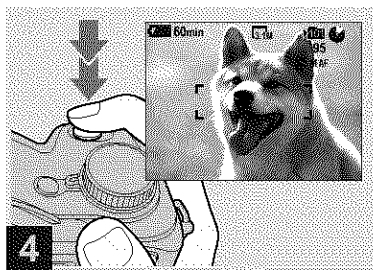

➔ **Press the shutter button fully down.**

The shutter sounds. The image will be recorded in the disc. When ACCESS lamp (page 10) goes out, you can shoot the next image.

- When operating the camera using a battery pack, if you do not operate the camera for about three minutes during recording, the camera turns off automatically to prevent wearing down the battery (page 15).
- While the image is being recorded on the disc, the ACCESS lamp flashes. Do not shake or strike the camera while this lamp is flashing. Also do not turn off the power, remove the battery pack, or open the disc cover at this time, as the data may be damaged or the disc may become unusable.

Mode dial for still image shooting

When shooting still images with your camera, you can choose from the following shooting methods.

(Auto adjustment mode)



The focus, exposure and white balance are automatically adjusted to allow easy shooting. The image quality is set to [Fine] (page 41).

(Program auto shooting)

You can set the desired shooting functions using menus (pages 40 and 101).

SCN (Scene Selection)

You can select from the following modes to shoot according to the scene conditions (page 55).

-  (Twilight mode)
-  (Twilight portrait mode)
-  (Landscape mode)
-  (Soft snap mode)
-  (Snow mode)
-  (Beach mode)
-  (High-speed shutter mode)

Auto Focus

When you try to shoot a subject that is difficult to focus on, the AE/AF lock indicator changes to flashing slowly. The Auto Focus function may have difficulty working under the following conditions. In such cases, release the shutter button, then recompose the shot and focus again.

- The subject is distant from the camera and dark.
- The contrast between the subject and its background is poor.
- The subject is seen through glass, such as a window.
- A fast-moving subject.
- The subject reflects or has a lustrous finish, such as a mirror or a luminous body.
- A flashing subject.
- A backlit subject.

There are two Auto Focus functions: "AF range finder frame" which sets the focus position according to the subject position and size, and "AF mode" which sets the focus operation according to the AF response and the battery consumption. See page 43 for details.

Checking the last image you shot — Quick Review

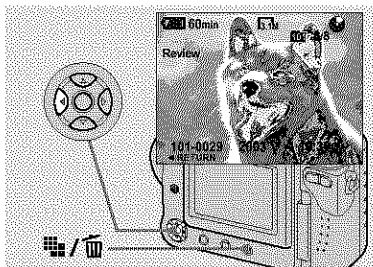

➔ Press ◀ (⏪) on the control button.

To return to the normal shooting mode, press lightly on the shutter button or press ◀ (⏪) again.

To delete the image displayed on the screen

- 1 Press / (Delete).
- 2 Select [Delete] with ▲ on the control button, then press ●. The image is deleted.

Using the zoom feature

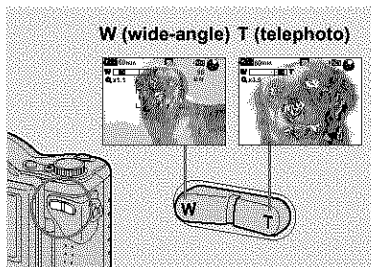

➔ Press the zoom button to choose the desired zoom position for shooting.

Minimum focal distance to the subject

When the zoom is set to the W side:
Approx. 50 cm (19 3/4 inches) from the lens surface

When the zoom is set to the T side:
Approx. 80 cm (31 1/2 inches) from the lens surface

Smart zoom

Digital processing lets you zoom in the image without deterioration.

When the zoom exceeds 3×, enlargement is carried out using the smart zoom. When the smart zoom is not needed, set [Smart Zoom] to [Off] in the SET UP settings (page 105). When you press the zoom button, the zoom scaling indicator appears on the LCD screen.

Zoom scaling indicator

The T side of this line shows the extent of smart zoom

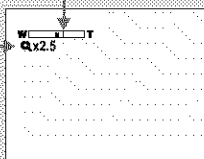

The maximum zoom scale depends on the image size.

[2.0M]: 3.8×

[1.2M]: 4.8×

[VGA]: 9.6×

When the image size is [3.1M] or [2.8M(3:2)], the smart zoom does not work.

- When using the smart zoom, the image on the LCD screen may look rough. However, this phenomenon has no effect on the recorded image.
- AF range finder is not shown when using the smart zoom. When ∞ (Focus) is set to [Multi AF] or [Center AF], \square or \square flashes and the centrally-located subject has priority to focus on.



The macro recording mode is used when zooming up a small subject, such as flowers or insects. You can shoot close-ups of subjects up to the distances specified below.



When the zoom is set all the way to the W side:

Approx. 3 cm (1 3/16 inches) from the lens surface



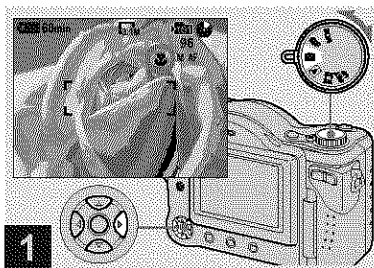

When the zoom is set all the way to the T side:

Approx. 80 cm (31 1/2 inches) from the lens surface





→ Set the mode dial to , and press  on the control button.

The  (macro) indicator appears on the screen.

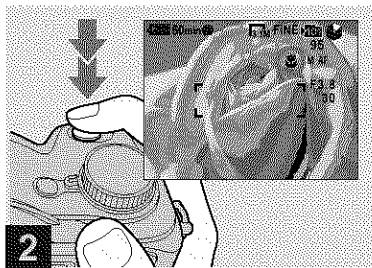

- If the menu is currently displayed, press MENU first so that the menu disappears.
- You can also carry out this operation when the mode dial is set to , SCN (other than ) (Twilight mode) or  (Landscape mode, page 55) or .



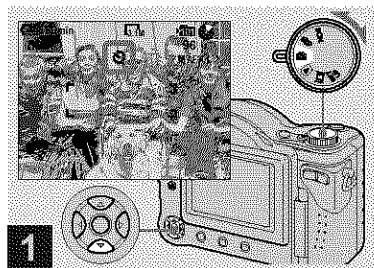

→ Center the subject in the frame, and press the shutter button fully down.

To return to normal recording mode
Press  on the control button again.
The  indicator disappears.



→ Turn the mode dial to , and press  on the control button.

The  (self-timer) indicator appears on the LCD screen.

- If the menu is currently displayed, press MENU first so that the menu disappears.
- You can also carry out this operation when the mode dial is set to , SCN or .

Selecting a flash mode

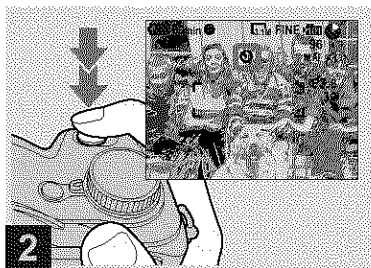

- ➔ **Center the subject in the frame, and press the shutter button fully down.**

The self-timer lamp (page 9) flashes and a beep sounds after you press the shutter button until the shutter operates (approximately 10 seconds).

To cancel the self-timer in the middle of the operation

Press **▼** (⊙) on the control button again. The ⊙ indicator disappears from the LCD screen.

- If you press the shutter button while standing in front of the camera, the focus and the exposure may not be correctly set.

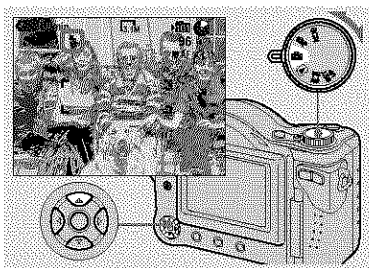

- ➔ **Set the mode dial to , and press **▲** ($\$$) on the control button repeatedly to select a flash mode.**

Each time you press **▲** ($\$$), the indicator changes as follows.





No indicator (Auto): The flash automatically strobos when shooting images in a dark place or against a light source.

$\$$ (Forced flash): The flash strobos regardless of the surrounding brightness.

$\$$ SL (Slow synchro): The flash strobos regardless of the surrounding brightness.

The shutter speed is slow in a dark place, so you can clearly shoot the background that is out of flash light.

\odot (No flash): The flash does not strobe.

- If the menu is currently displayed, press MENU first so that the menu disappears.
- You can also carry out this operation when the mode dial is set to ****, SCN (**** Soft snap mode) or **** (Clip Motion).
- The recommended shooting distance using the flash is approximately 0.8 m to 2.5 m (31 1/2 inches to 8 feet 2 7/16 inches) (when [ISO] is set to [Auto]).
- You can change the brightness of the flash with [Flash Level] in the menu settings (page 102). (You cannot change the brightness of the flash while the mode dial is set to ****.)
- When using the **$\$$ SL** (Slow synchro) or **\odot** (No flash) mode, the shutter speed becomes slower in dark places, so using a tripod is recommended.
- While charging the flash, the **$\$$ /CHG** lamp flashes. After the charging is complete, the lamp goes out.
- When you press the shutter button halfway down while the flash is strobing, the **$\$$ /CHG** lamp turns on.
- Attaching a conversion lens (not supplied) may block the light from the built-in flash or cause the lens shadow to appear.
- This setting is maintained even when the power is turned off.

When shooting images against a light source

If the flash is set to Auto (no indicator), shooting against a light source automatically flashes even when there is enough light around the subject (Daylight synchro).

Before flashed



When flashed



- The best performance may not be given depending on shooting conditions.
- When you do not want to use the flash, set the flash mode to  (No flash).

To reduce the red-eye phenomenon when shooting live subjects

Set [Red Eye Reduction] to [On] in the SET UP settings (page 105).  indicator appears on the LCD screen, and the flash pre-strobes before shooting to reduce the red-eye phenomenon.



- Red-eye reduction may not produce the desired effects depending on individual differences, the distance to the subject, if the subject does not see the pre-strobe, or other conditions.



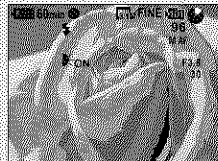

Recording images with the AF illuminator

The AF illuminator is fill light to focus more easily on a subject in dark surroundings. When not using this function, set [AF Illuminator] to [Off] in the SET UP settings (page 105).

 ON appears on the screen and the AF illuminator emits red light when the shutter button is pressed halfway until the focus is locked.



Indicators on the screen during shooting

- If the AF illuminator light does not reach the subject sufficiently or the subject has weak contrast, focus will not be achieved. (An approximate distance of 0.3 m to 2.3 m (11 7/8 inches to 7 feet 6 1/2 inches) is recommended.)
- Focus is achieved as long as AF illuminator light reaches the subject, even if the light is slightly off the center of the subject.
- When the focus preset distance is set (page 46), the AF illuminator does not function.
- The AF illuminator emits very bright light. Although there are no problems with safety, directly looking into the AF illuminator at close range is not recommended.
- When  (Focus) is set to [Multi AF] or [Center AF], the AF range finder is not displayed.  or  flashes and the centrally-located subject has priority to focus on.
- The AF illuminator does not operate when SCN is set to  (Twilight mode) or  (Landscape mode) in the menu settings (page 55).

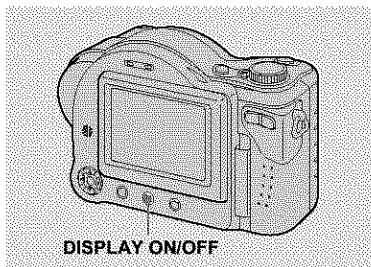

Each time you press DISPLAY ON/OFF, the display changes in the following order.

Indicators on

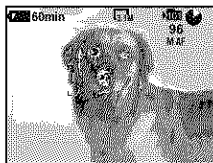

Indicators off

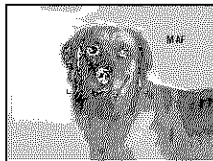

- For a detailed description of the indicators, see page 113.
- The setting selected here is maintained even when the power is turned off.

Inserting the date and time on a still image

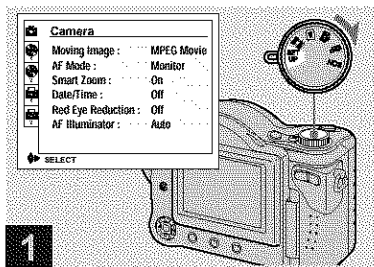

➔ Set the mode dial to **SET UP**.

The SET UP screen appears.

- When images are shot with the date and time superimposed, the date and time cannot be removed later.
- The date and time do not appear on the LCD screen during shooting, instead, "DATE" appears in the upper left corner of the LCD screen. The actual date and time appear in red during playback only.

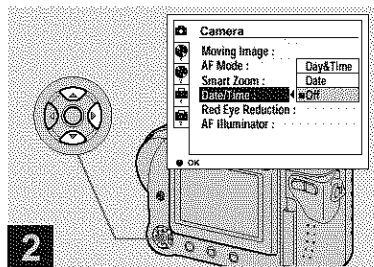

➔ Select **Camera** with **▲** on the control button, then press **▶**.

Select **[Date/Time]** with **▲/▼**, then press **▶**.

- If you select [Date], the date is superimposed onto the image in the order selected in "Setting the date and time" (page 16).

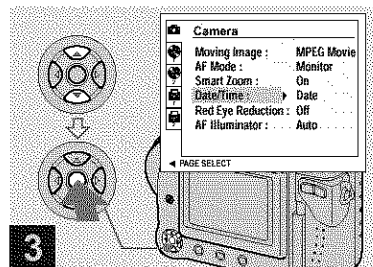

➔ Select the date and time setting with **▲/▼** on the control button, then press **●**.

Day & Time: Superimposes the date, hour, and minute onto the image.

Date: Superimposes the year, month and day onto the image.

Off: Does not superimpose the date and time onto the image.

After the setting has been completed, set the mode dial to **📷**, and shoot the image.

- You can also superimpose the date and time with the mode dial set to **📷P** or **SCN**.
- This setting is maintained even when the power is turned off.

Viewing images on the LCD screen of your camera

Single (single-image) screen



Index (nine-image) screen

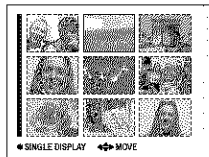

Index (triple-image) screen

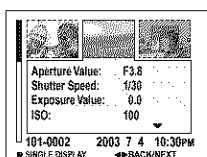

You can view images shot with your camera almost immediately on the LCD screen.

You can select the following three methods for viewing images.

Single (single-image) screen

You can view one image at a time, displayed over the entire screen.

Index (nine-image) screen

Nine images are displayed simultaneously in separate panels on the screen.

Index (triple-image) screen

Three images are displayed simultaneously in separate panels on the screen. Various image information items are also displayed.

- For a detailed description of the screen indicators, see page 113.
- For details on viewing movies, see page 71.

Viewing single images

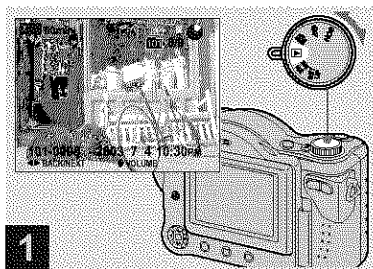

- ➔ **Set the mode dial to , and turn on the power.**

The last image in the selected recording folder (page 41) appears on the screen.

Viewing an index screen (nine-image or triple-image)

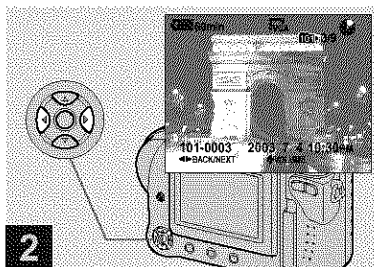

→ Select the desired still image with ◀/▶ on the control button.

◀: To display the preceding image
▶: To display the next image

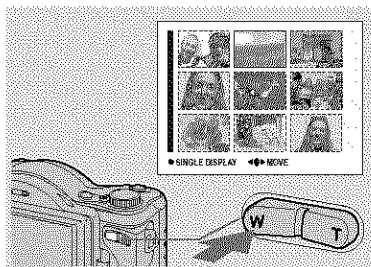

→ Press the zoom W (index) button once.

The display switches to the **Index (nine-image) screen**.

To display the next (previous) index screen

Press ▲/▼/◀/▶ on the control button to move the yellow frame up/down/left/right.

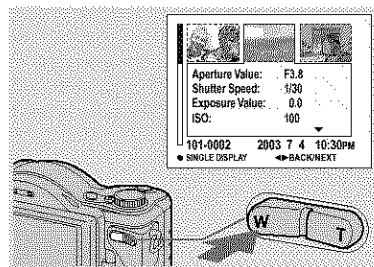

→ Press the zoom W (index) button once more.

The display switches to the **Index (triple-image) screen**.

Press ▲/▼ on the control button to display the remaining image information.

To display the next (previous) index screen

Press ◀/▶ on the control button.

To return to the single-image screen

Press the zoom T repeatedly, or press ● on the control button.

Viewing images on a TV screen

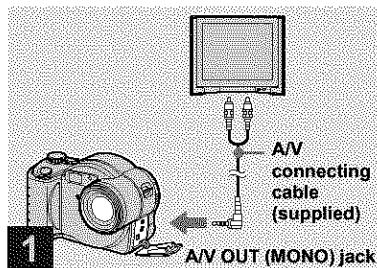

- ➔ Connect the supplied A/V connecting cable to the A/V OUT (MONO) jack of the camera and the audio/video input jacks of the TV.

If your TV has stereo input jacks, connect the audio plug (black) of the A/V connecting cable to the Lch jack.

- Turn off both your camera and the TV before connecting the camera and the TV with the A/V connecting cable.
- We recommend using the AC Adaptor (supplied) to prevent the power from turning off partway.

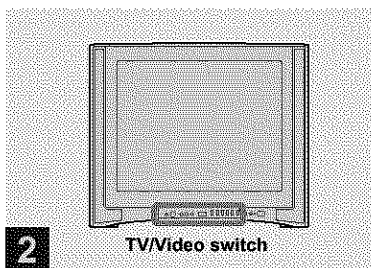

- ➔ Turn on the TV and set the TV/Video switch to "Video".

- The name and location of this switch may differ depending on your TV. For details, see the operating instructions supplied with the TV.

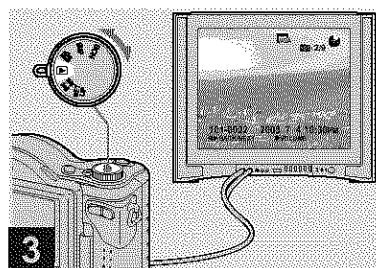

- ➔ Set the mode dial to , and turn on the camera.

Press  on the control button to select the desired image.

- When using your camera abroad, it may be necessary to switch the video output signal to match that of your TV system (page 106).

Viewing images on a TV screen

If you want to view images on a TV screen, you need a TV with a video input jack and the A/V connecting cable (supplied).

The color system of the TV must match that of your digital still camera. Check the following lists:

NTSC system

Bahama Islands, Bolivia, Canada, Central America, Chile, Colombia, Ecuador, Jamaica, Japan, Korea, Mexico, Peru, Surinam, Taiwan, the Philippines, the U.S.A., Venezuela, etc.

PAL system

Australia, Austria, Belgium, China, Czech Republic, Denmark, Finland, Germany, Holland, Hong Kong, Italy, Kuwait, Malaysia, New Zealand, Norway, Portugal, Singapore, Slovak Republic, Spain, Sweden, Switzerland, Thailand, United Kingdom, etc.

PAL-M system

Brazil

PAL-N system



Argentina, Paraguay, Uruguay

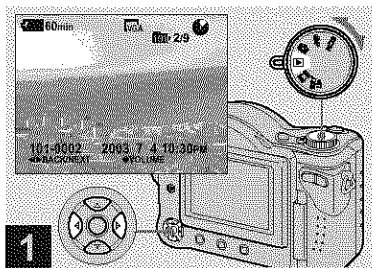

SECAM system

Bulgaria, France, Guiana, Hungary, Iran, Iraq, Monaco, Poland, Russia, Ukraine, etc.

Deleting images



- ➔ **Set the mode dial to , and turn on the camera. Press  on the control button to select the image you want to delete.**

- When using a CD-R, the disc remaining space does not increase even if you delete images.
- When using a CD-RW, the disc remaining space increases only if you delete the last image you shot while  is indicated on the LCD screen. If you modify an image, or open and close the disc cover,  disappears.
- It may take some time to delete the images.

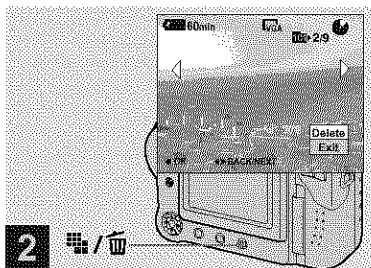



- ➔ **Press  /  (Delete).**

The image has not yet been deleted at this point.

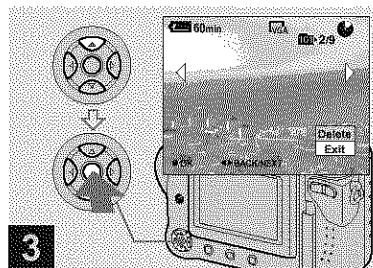

- You cannot delete the protected image (page 65).
- If the disc remaining space is not sufficient, you may not be able to delete the image.





- ➔ **Select [Delete] with  on the control button, then press .**

When the message "Disc access" disappears, the image has been deleted.

To continue and delete other images

Display the image to be deleted with  on the control button. Then, select [Delete] with  and press .

To cancel deleting

Select [Exit] with  on the control button, then press .

Deleting images in index (nine-image) mode

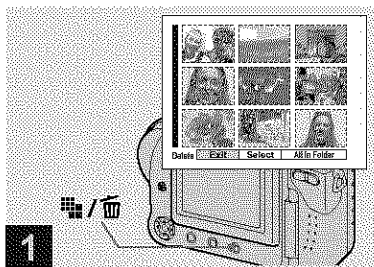

1 → While an index (nine-image) screen (page 32) is displayed, press / (Delete).

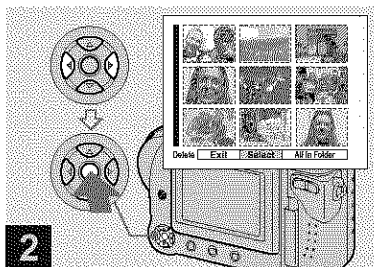

2 → Select [Select] with / on the control button, then press .

To delete all the images in the folder
Select [All In Folder] with on the control button, then press . Select [OK], then press . All of the unprotected images in the folder are deleted. To cancel deleting, select [Cancel], then press .

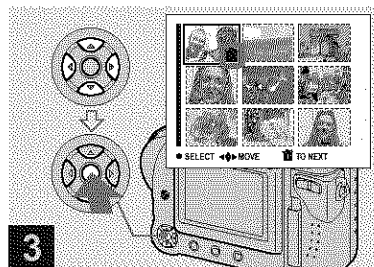





3 → Select an image you want to delete with / / / on the control button, then press .

The green indicator appears on the selected image. At this point, the image has not yet been deleted. Repeat this step for all of the images you want to delete.

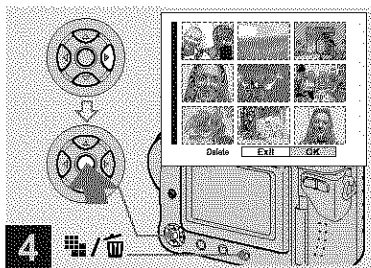
- To cancel a selection, press again so that the indicator disappears.



Deleting images in index (triple-image) mode





- ➔ Press  (Delete) and select [OK] with  on the control button, then press .

When the message “Disc access” disappears, the images have been deleted.

To cancel deleting

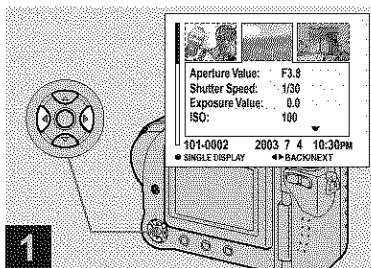
Select [Exit] with  on the control button, then press .



- ➔ While an index (triple-image) screen (page 32) is displayed, set the image you want to delete to the center with /  on the control button.

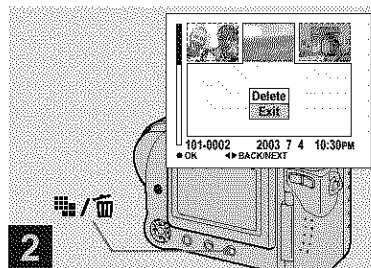

- ➔ Press  (Delete).

The image has not yet been deleted at this point.

Formatting a CD-RW

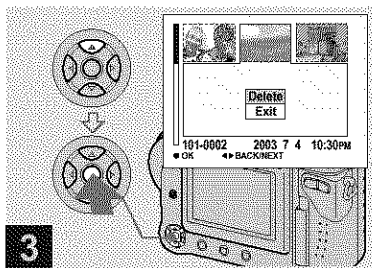

➔ Select [Delete] with ▲ on the control button, then press ●.

When the message “Disc access” disappears, the image has been deleted.

To cancel deleting

Select [Exit] with ▼ on the control button, then press ●.

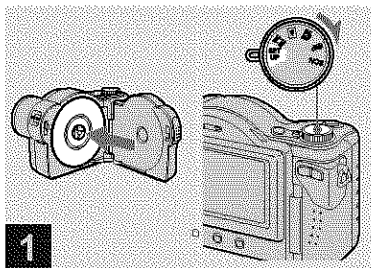

➔ Place the CD-RW you want to format in the disc tray. Set the mode dial to SET UP, and turn on the camera.

- A CD-R cannot be formatted.
- Formatting is performed to delete all the images on the CD-RW or to use a CD-RW formatted with other equipment than this camera.
- **When you format a CD-RW, all data stored on the disc including protected images will be deleted. The CD-RW is also automatically initialized after formatting.**

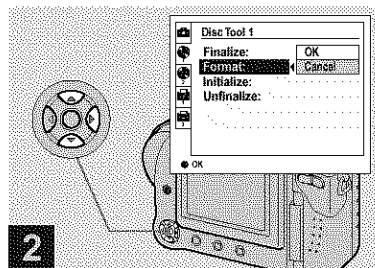

➔ Select  (Disc Tool 1) with ▲/▼ on the control button, then press ►. Select [Format] with ▲/▼, then press ►.

- We recommend using the AC Adaptor to prevent the power from turning off partway through the formatting.

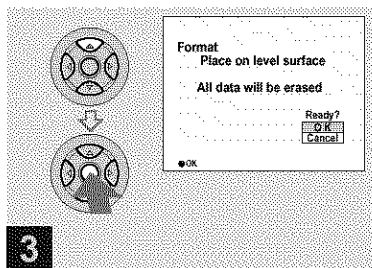

3 → Select [OK] with ▲ on the control button, then press ●.

“Format Place on level surface” appears on the LCD screen.

To cancel formatting

Select [Cancel] with ▼ on the control button, then press ●.

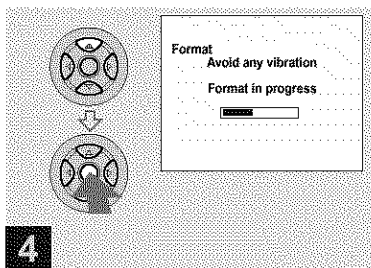

4 → Select [OK] with ▲, then press ●.

When the message “Format in progress” disappears, formatting has been completed.

- It may take some time to format a CD-RW.
- A CD-RW can be formatted about 300 times.
- A CD-RW formatted using other equipment than this camera cannot be used with this camera. Format the disc again with this camera.

How to setup and operate your camera

The usage of the menus and SET UP screen items that are most frequently used for “Advanced operations” is described below.

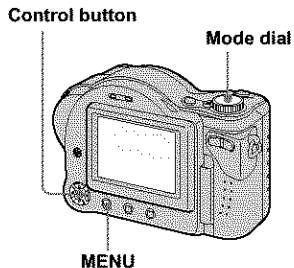

Changing the menu settings

- 1 Press MENU.

The menu appears.

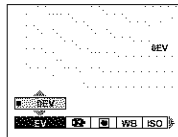

- 2 Press ◀/▶ on the control button to select the item you want to set.

The selected item turns yellow.

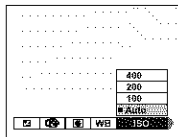

- 3 Press ▲/▼ on the control button to select the desired setting.

The frame of the selected setting turns yellow, and the setting is entered.

To turn off the menu display

Press MENU.

Changing the items in the SET UP screen

- 1 Set the mode dial to SET UP.

The SET UP screen appears.

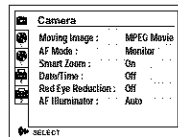

- 2 Press ▲/▼/◀/▶ on the control button to select the item you want to set.

The frame of the selected item turns yellow.

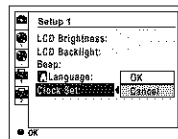

- 3 Press ● on the control button to enter the setting.

To turn off the SET UP screen display

Set the mode dial to anything other than SET UP.

Deciding the still image quality

Mode dial: P/SCN

You can select the still image quality from [Fine] or [Standard].

Control button

Mode dial

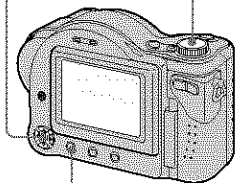





MENU

1 Set the mode dial to P or SCN.

2 Press MENU.

The menu appears.

3 Select  (P. Quality) with / , then select the desired image quality with / .

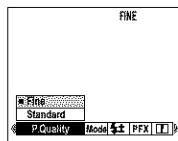

- You can also carry out this operation when the mode dial is set to  (Multi Burst only) (page 51).
- This setting is maintained even when the power is turned off.

Creating or selecting a folder

Mode dial: SET UP

Your camera can create multiple folders within a disc. You can select the folder used to store images.

When not creating a new folder, "101MSDCF" folder is selected as the recording folder.

You can create folders up to "999MSDCF."

Control button

Mode dial

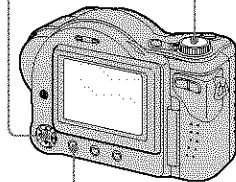

MENU

- Up to 4000 images can be stored in one folder. When the folder capacity is exceeded, a new folder is automatically created.

Creating a new folder

- 1 Set the mode dial to SET UP.
- 2 Select  (Disc Tool 2) with **▲/▼**, [Create REC. Folder] with **▶/▲/▼**, and [OK] with **▶/▲**, then press **●**.

The following screen appears.



- 3 Select [OK] with **▲**, then press **●**.

A new folder is created with a number one higher than the largest number in the disc, and the folder becomes the recording folder.

To cancel folder creation

Select [Cancel] in step **2** or **3**.

- Once you create a new folder, you cannot delete the new folder with the camera.
- Images are recorded in the newly created folder until a different folder is created or selected.

Changing the recording folder

- 1 Set the mode dial to SET UP.
- 2 Select  (Disc Tool 2) with **▲/▼**, [Change REC. Folder] with **▶/▲/▼**, and [OK] with **▶/▲**, then press **●**.

The recording folder selection screen appears.

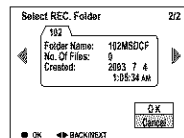

- 3 Select the desired folder with **◀/▶**, and [OK] with **▲**, then press **●**.

To cancel changing the recording folder

Select [Cancel] in step **2** or **3**.

- You cannot select the “100MSDCF” folder as a recording folder.
- The image is stored in the newly selected folder. You cannot move images to a different folder with this camera.

Choosing an auto focus method

You can set the AF range finder frame and the AF mode.

AF focus range finder frame

The AF range finder frame selects the focus position according to the subject position and size.

AF Mode

The AF mode sets the focus operation according to the AF response and the battery consumption.

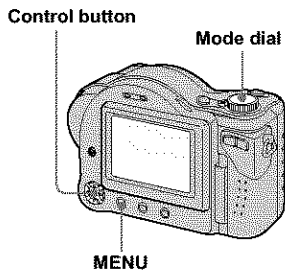

Choosing a focus range finder frame

— AF range finder

Mode dial: P/SCN/

Multipoint AF

The camera calculates the distance in three places to the left and right and in the center of the image, letting you shoot using the auto focus function without worrying about the image composition. This is useful when it is difficult to focus on the subject because it is not in the center of the frame. You can check the position where the focus was adjusted using the green frame.

The Multipoint AF is the factory setting.

Center AF

The AF range finder is only the center of the frame. You can shoot in desired image composition using the AF lock method.

1 Set the mode dial to P, SCN or .

2 Press MENU.

The menu appears.

3 Select (Focus) with /▶, then select [Multi AF] or [Center AF] with ▲/▼.

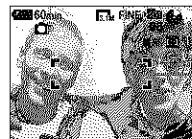

The focus is adjusted automatically. When you press and hold the shutter button halfway down and the focus is adjusted, the color of the AF range finder frame changes from white to green.

Multipoint AF



Center AF



- When you are shooting movies (MPEG Movie) and you choose Multipoint AF, the distance to the center of the screen is estimated as an average, so the AF works even with a certain amount of vibration. The Center AF automatically focuses only on the center of the image, so it is convenient when you want to focus only on what you aim at.
- When you use the smart zoom or AF illuminator, priority AF movement is given to subjects in or near the center of the frame. In this case,  or  flashes and the AF range finder frame is not displayed.

Choosing a focus operation

— AF Mode

Mode dial: SET UP

You can select from the following three focus modes for your camera.

Single AF

This mode allows accurate focusing over a wide range from near to distant subjects, and is useful for shooting stationary subjects. The focus is not adjusted before the shutter button is pressed and held halfway down. When the shutter button is pressed and held halfway down and AF lock is complete, the focus is locked.

Monitoring AF

This shortens the time needed for focusing. The camera adjusts the focus before the shutter button is pressed and held halfway down, letting you compose images with the focus already adjusted. When the shutter button is pressed and held halfway down and AF lock is complete, the focus is locked. The factory setting is Monitoring AF.

- Battery consumption may be faster than in Single AF mode.

Continuous AF

The camera adjusts the focus before the shutter button is pressed and held halfway down, and then continues to adjust the focus even after AF lock is completed. This allows shooting of moving subjects with continued focus.

- The focus is not adjusted after the lock is completed in the following cases, and the C AF indicator flashes. The camera operates in Monitoring AF mode.
 - When shooting in the dark place
 - When shooting with a slow shutter speed
- The AF range finder frame is locked to the center.
- Focus adjustment may not be able to keep up when shooting fast moving subjects.
- There is no lock sound when the focus is adjusted.
- When recording with the self timer, the focus is locked when you press the shutter button all the way down.
- Battery consumption may be faster than in any other AF mode.

- 1** Set the mode dial to SET UP.
- 2** Select  (Camera) with ▲, [AF Mode] with ►/▲/▼.
- 3** Select the desired mode with ►/▲/▼, then press ●.

- When shooting in Macro mode, the AF speed drops in order to focus accurately on close subjects. For quicker shooting, using a different mode than Macro mode is recommended.

Shooting techniques

When shooting with the subject at the edge of the frame, the camera may focus on the center instead of on the subject at the edge of the frame. In a case like this, use AF lock to focus on the subject, and then recompose the picture and shoot (except in Continuous AF mode).

Compose the shot so that the subject is centered in the AF range finder, and press the shutter button halfway down.

When the AE/AF lock indicator stops flashing and remains on, return to the fully composed shot, and press the shutter button fully down.

- When you are using AF lock, you can capture an image with the correct focus even if the subject is at the edge of the frame.
- You can carry out the AF lock adjustment process before you press the shutter button fully down.

AE/AF lock indicator



AF range
finder frame



Setting the distance to the subject

— Focus preset

Mode dial: P/SCN/

When shooting an image using a previously set distance to the subject, or when shooting a subject through a net or through window glass, it is difficult to get the proper focus in auto focus mode. In these cases, use of the Focus preset is convenient.

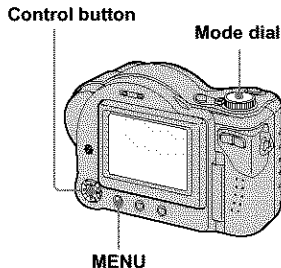

1 Set the mode dial to P, SCN, or .

2 Press MENU.

The menu appears.

3 Select (Focus) with /▶, then select the distance to the subject with ▲/▼.

You can select from the following distance settings
0.5m, 1.0m, 3.0m, 7.0m and ∞ (infinity)



To reactivate auto focusing

In step **3**, select (Focus), then select [Multi AF] or [Center AF].

- Focus setting information is approximate, and should be used as a reference.
- If you point the lens up or down, the error will increase.
- If you select 0.5 m (9 3/4 inches) with the zoom set to the T side, you may not get a clear focus. In such cases, the focus setting information flashes. Press the zoom W button until the indicator stops flashing.
- The focus preset does not work properly when attaching a conversion lens (not supplied).

Adjusting the exposure

— EV adjustment

Mode dial: P/SCN/

This lets you adjust the exposure value which is set by automatic adjustment. You can select values ranging from +2.0EV to -2.0EV in steps of 1/3EV.

Control button

Mode dial

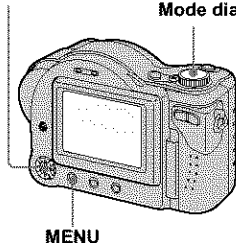

1 Set the mode dial to **P**, **SCN** or **M**.

2 Press **MENU**.

The menu appears.

3 Select **EV** with **◀/▶**.

The value of the exposure adjustment is displayed.



4 Select the desired exposure value with **▲/▼**.

Adjust the exposure value while checking the brightness of the background.

To reactivate auto exposure

Return the exposure adjustment value to 0EV.

- If a subject is being shot in extremely bright or dark conditions, or the flash is used, the exposure adjustment may not be effective.

Shooting techniques

Normally, the camera automatically adjusts the exposure. If the image is too dark or too bright as shown below, we recommend that you adjust the exposure manually. When shooting a back-lit subject or a subject against a white (e.g. snowy) background, adjust the exposure toward the + side. When shooting a black, subject that fills the screen, adjust the exposure toward the - side.



Underexposed
→ Adjust toward +



Appropriate exposure



Overexposed
→ Adjust toward -

Selecting the metering mode

Mode dial: **P/SCN/M**

This function enables you to select the metering mode to suit the shooting conditions and purpose.

Multi-pattern metering

The image is divided into multiple regions and metering is performed for each region. The camera judges the subject position and background brightness, and determines a well-balanced exposure.

The camera is set to multi-pattern metering as the factory setting.

Spot metering

Light is measured only for the specific region where the subject is located. This lets you adjust the exposure to the subject even when the subject is backlit or there is strong contrast between the subject and the background.

Position the spot metering cross hair on one point of the subject you want to shoot.

To focus on the metering position, setting **AF** (Focus) to [Center AF] is recommended (page 43).

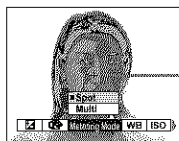

Spot metering
cross hair

Control button

Mode dial

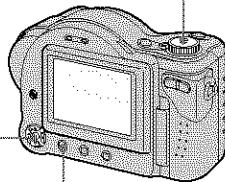

MENU

- 1** Set the mode dial to **P**, **SCN** or **[M]**.
- 2** Press **MENU**.
The menu appears.
- 3** Select **[M]** (Metering Mode) with **◀/▶**, then select **[Multi]** or **[Spot]** with **▲/▼**.

Adjusting color tones

— White Balance

Mode dial: **P**/SCN/[M]

When the white balance is set to Auto, the white balance is automatically set and the overall color balance is adjusted according to the shooting conditions. However, when you shoot under fixed conditions or special lighting conditions, you can manually adjust the white balance.

Auto (no display)

Adjusts the white balance automatically

(Daylight)

Shooting outdoors, shooting night scenes, neon signs, fireworks or sunrises, or shooting just before and after sundown

(Cloudy)

Shooting under a cloudy sky

(Fluorescent)

Shooting under fluorescent lighting

(Incandescent)

- Places where the lighting conditions change quickly
- Under bright lighting such as photography studios

WB (Flash)

Adjusts the white balance only to the flash conditions

Control button

Mode dial

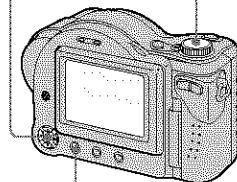



MENU

- 1** Set the mode dial to **P**, **SCN** or **[M]**.
- 2** Press **MENU**.
The menu appears.
- 3** Select **[WB]** (White Bal) with **◀/▶**, then select the desired setting with **▲/▼**.

To reactivate auto adjustment

Select **[Auto]** in step **3**.

- Under fluorescent lights that flicker, the white balance adjustment function may not work correctly even though you select  (Fluorescent).
- When the flash strobes, the manual setting is canceled, and the image is recorded in [Auto] mode (except in WB (Flash) mode).

Shooting techniques

The subject coloring is affected by the lighting conditions. For example, the entire image appears blue under sunlight in the summer, and white items gain a reddish tint under incandescent light bulbs, etc. The human eye can resolve these problems, but digital still cameras cannot recognize the correct colors without adjustments. Normally, the camera makes these adjustments automatically, but if recorded image colors appear unnatural, we recommend that you adjust the white balance.

Adjusting the flash level

— Flash Level

Mode dial: P/SCN

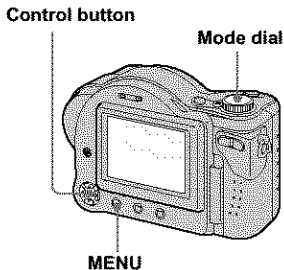

You can adjust the amount of flash light.



1 Set the mode dial to P or SCN.

2 Press MENU.

The menu appears.

3 Select [\pm] (Flash Level) with , then select the desired setting with .

High: Makes the flash level higher than normal.

Normal: Normal setting.

Low: Makes the flash level lower than normal.

- You can carry out this operation even when the mode dial is set to  (Clip Motion).

Shooting multiple frames

— Clip Motion

Mode dial:

You can shoot a number of consecutive still images (GIF animation). The GIF format has a small file size, making it convenient for creating home pages or attaching images to e-mail.

- Due to the limitations of the GIF format, the number of colors for Clip Motion images is reduced to 256 colors or less. Therefore, the image quality may deteriorate for some images.

Normal (160×120)

Clip Motion of up to 10 frames can be recorded. This is suitable for use on home pages, etc.

Mobile (120×108)





Clip Motion of up to two frames can be recorded. This is suitable for use with portable data terminals.

- The file size is reduced in Mobile mode, so the image quality deteriorates.

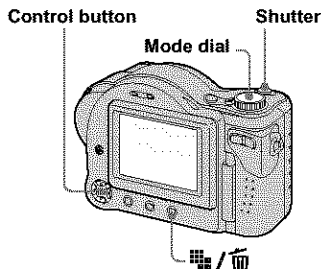
Before operation

Set [Moving Image] to [Clip Motion] in the SET UP settings (pages 40 and 105).



- 1 Set the mode dial to .**
- 2 Press  /  (Image Size).**
The Image Size setup appears.
- 3 Select the desired mode with  / .**
You can select from [Normal] or [Mobile].

- 4 Shoot the image for the first frame.**

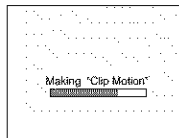





- 5 Shoot the image for the next frame.**

Press the shutter button to shoot the next frame, then repeat this operation until you have shot the desired number of frames.

- 6 Press .**

All the frame images are recorded on the disc.

To delete some or all of the frame images while making a Clip Motion recording

- Press  (Ⓢ) in step **4** or **5**.
The frame images you shot are played back in turn and stop at the last image.
- Press  (Delete), and select [Delete Last], or [Delete All] with  / , then press .

- 3 Select [Delete] with ▲, then press ●. When [Delete Last] is selected in step 2, each time you repeat steps 1 through 3, the last frame you shot is deleted.

- Note that all images are not recorded on the disc until you carry out step 6.
- For the number of images that can be recorded in Clip Motion, see page 100.
- The date and time are not superimposed onto Clip Motion images.
- When viewing an image recorded in Clip Motion on the index screen, the image may appear different from the actual image.
- GIF files not created on this camera may not be displayed correctly.

Shooting in Multi Burst mode

— Multi Burst

Mode dial: 



This mode records 16 frames in succession each time you press the shutter button. This is convenient for checking your form in sports, for example.

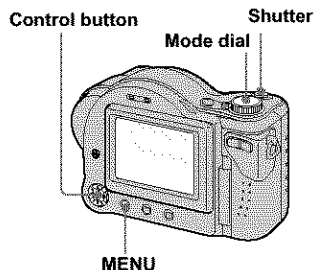

Before operation

Set [Moving Image] to [Multi Burst] in the SET UP settings (pages 40 and 105).



- 1 Set the mode dial to .
- 2 Press MENU.
The menu appears.
- 3 Select  (Interval) with ◀▶, then select the desired frame interval with ▲▼.

You can choose the frame interval from the menu settings (pages 40 and 103).



4 Shoot the image.

The 16 frames are recorded as a single image (image size: 1.2M).

- See page 63 to play back images recorded in Multi Burst mode using this camera.
- For the number of images that can be recorded in Multi Burst mode, see page 100.
- You cannot use the flash in this mode.
- Date and time cannot be superimposed onto images.

Shooting two images continuously

— Burst 2

Mode dial: / P / SCN

This mode is used for continuous shooting. Each time you press the shutter button in this mode, the camera records two images in succession.

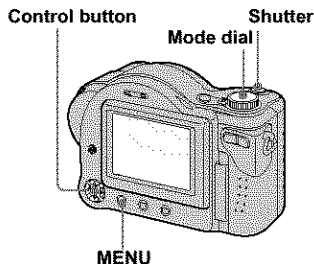

1 Set the mode dial to , P or SCN.

2 Press MENU.

The menu appears.

3 Select [Mode] (REC Mode) with / , then select [Burst 2] with / .



4 Shoot the image.

When the “Recording” indication disappears, you can shoot the next image.

To return to normal mode

Select [Normal] in step 3.

- You cannot use the flash in this mode.
- During shooting in this mode, the images are not displayed on the screen. Compose the image before pressing the shutter button.
- The recording interval is approximately 0.5 second.

Shooting still images in TIFF mode

— TIFF

Mode dial: / / SCN

This mode records an image without compression, so the image quality does not deteriorate. Images recorded in this mode are suitable for editing on a computer, etc.

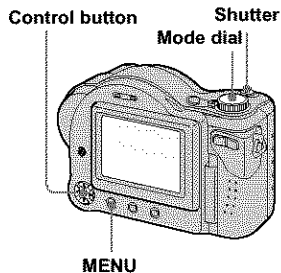

- 1** Set the mode dial to , or SCN.
- 2** Press MENU.
The menu appears.
- 3** Select [Mode] (REC Mode) with , then select [TIFF] with .

4 Shoot the image.

When the “Recording” indication disappears, you can shoot the next image.

To return to normal mode

Select [Normal] in step **3**.

- JPEG images are also recorded in the image size selected by the (Image Size) menu (page 20). Uncompressed (TIFF) images are recorded in [3.1M] size except when [2.8M (3:2)] is selected.
- Writing data takes more time than in normal recording mode.
- For the number of images you can record in TIFF mode, see page 99.

Shooting still images for e-mail

— E-Mail

Mode dial: / / SCN

In E-mail mode, a small-size image (320×240) that is suitable for e-mail transmission is also recorded at the same time as recording a normal still image. (See page 20 for the normal still image sizes.)

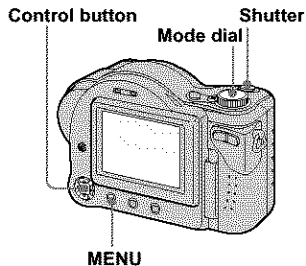

- 1** Set the mode dial to , or SCN.
- 2** Press MENU.
The menu appears.

- 3** Select [Mode] (REC Mode) with **◀/▶**, then select [E-Mail] with **▲/▼**.

4 Shoot the image.

When the “Recording” indication disappears, you can shoot the next image.

To return to normal mode

Select [Normal] in step **3**.

- For instructions on how to attach images to an e-mail message, consult the User’s Manual for your e-mail software.
- For the number of images you can record in E-mail mode, see page 99.

Shooting still images with audio files

— Voice

Mode dial: **📷/📷P/SCN**

In Voice mode, an audio track is also recorded at the same time as recording a normal still image.

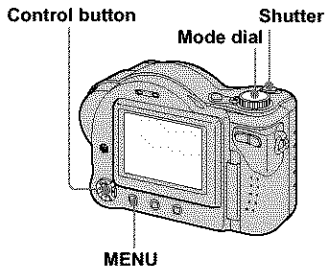

- 1** Set the mode dial to **📷**, **📷P** or **SCN**.
- 2** Press **MENU**.
The menu appears.
- 3** Select [Mode] (REC Mode) with **◀/▶**, then select [Voice] with **▲/▼**.

4 Shoot the image.

If you press and release the **shutter button**, sound is recorded for five seconds.

If you **hold down the shutter button**, sound is recorded until you release the shutter button for up to 40 seconds.

To return to normal mode

Select [Normal] in step **3**.

- To view images recorded in Voice mode, carry out the same procedure described in “Viewing movies on the LCD screen” (page 71).
- For the number of images you can record in Voice mode, see page 99.

Shooting according to scene conditions

— Scene Selection

Mode dial: SCN

When shooting night scenes, shooting people at night, shooting landscapes, shooting portraits, shooting snowy scenes, shooting at the shore, or shooting with priority on the shutter speed such as motion scenes, use the following modes to increase the quality of your images.

☾ Twilight mode

Allows you to shoot night scenes at far distance without losing the dark atmosphere of the surroundings. The shutter speed becomes slower, so we recommend that you use a tripod to prevent shaking.



- You cannot shoot in macro mode.
- You cannot use the flash.

🌙 Twilight portrait mode

Suitable for shooting portraits in dark places. Allows you to shoot sharp images of people in dark places without losing the dark atmosphere of the surroundings. The shutter speed becomes slower, so we recommend that you use a tripod to prevent shaking.



- The flash strobos regardless of the surrounding brightness.

🏔 Landscape mode

Focuses on a distant subject to shoot landscapes, etc.



- You cannot shoot in macro mode.
- The flash is set to ⚡ (Forced flash) or ⚡ (No flash).

👤 Soft snap mode

The soft snap mode lets you shoot skin colors in brighter and warmer tones for more beautiful pictures. In addition, the soft focus effect creates a gentle atmosphere for portraits of people, flowers, etc.



❄ Snow mode

When shooting snowy scenes or other places where the whole screen appears white, use this mode to prevent sunken colors and record clear and sharp images.

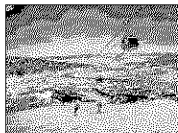



- The flash is set to ⚡ (Forced flash) or ⚡ (No flash).

Beach mode

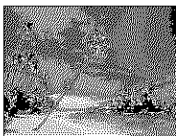
When shooting seaside or lakeside scenes, the blue of the water is clearly recorded.





- The flash is set to  (Forced flash) or  (No flash).

High-speed shutter mode

Use this mode to shoot moving subjects outdoors or in other bright places.



- The shutter speed becomes faster, so images shot in dark places become darker.
- The flash is set to  (Force flash) or  (No flash).

Control button

Mode dial

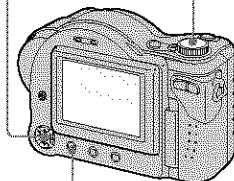

MENU

1 Set the mode dial to SCN.

2 Press MENU.

The menu appears.

3 Select [SCN] with , then select the desired mode with .

To cancel Scene Selection

Set the mode dial to a different mode.

- If you record in Burst 2 mode, the shutter speed becomes faster, so the image may not be recorded just as you intended.
- The setting is maintained even when the power is turned off.

NR slow shutter

The NR slow shutter function removes noise from recorded images, providing clear images. When the shutter speed is low, the NR slow shutter function activates automatically and “NR” appears before the shutter speed indication.



Press the shutter button fully down.

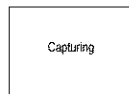

Then the screen turns black.

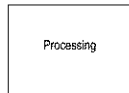

Finally, when “Processing” disappears, the image has been recorded.

- To eliminate the effects of vibration, use of a tripod is recommended.

Adding special effects

— Picture Effect

Mode dial: P/SCN/

You can digitally process images to obtain special effects.

Solarize



The light contrast is clearer and the picture looks like an illustration.

B&W



The picture is monochrome (black and white).

Sepia



The picture is sepia-toned like an old photograph.

Neg.Art



The color and brightness of the picture are reversed as in a negative.

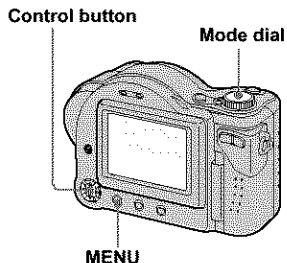

- 1** Set the mode dial to P, SCN or .
- 2** Press MENU.
The menu appears.
- 3** Select [PFX] (P. Effect) with **◀** / **▶**, then select the desired mode with **▲** / **▼**.

To cancel Picture Effects

Select [Off] in step **3**.

Confirming whether to record images

— Confirm before write

Mode dial: / P/SCN

When this function is activated, recorded images are temporarily stored in the camera memory, letting you confirm whether or not to save the images you have recorded on a disc. If you delete an unwanted image before recording, the disc remaining space does not decrease.

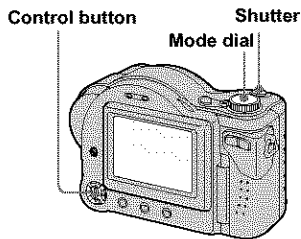

- 1** Set the mode dial to SET UP.
- 2** Select (Disc Tool 2) with **▲** / **▼**, [Confirm B. Write] with **▶** / **▼**, and [On] with **▶** / **▲**, then press **●**.
- 3** Set the mode dial to , P or SCN.

4 Record the image.

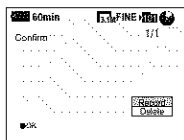

5 Select [Record] or [Delete] with ▲/▼, then press ●.

If you select [Record]

“Recording” appears on the screen, and the image will be recorded on the disc.

If you select [Delete]

Select [Delete], then press ● to not record the image on the disc.
Select [Cancel], then press ● to return to the previous screen.

- You can carry out this operation even when the mode dial is set to  (Multi Burst).

To confirm recording of images shot in the Burst 2 mode

You can confirm whether to record each of the images by pressing ◀/▶ in step 5 and displaying the two images in order.

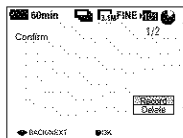

Selecting the folder and playing back images

— Folder

Mode dial:

Select the folder that images you want to playback are stored.

Control button

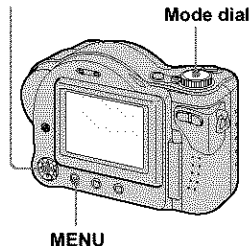

1 Set the mode dial to .

2 Press MENU.

The menu appears.

3 Select [Folder] with , then press .

4 Select the desired folder with / .

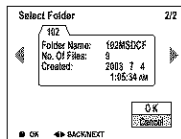

5 Select [OK] with , then press .

To cancel the selection

In step 5, select [Cancel].

When multiple folders are created in the disc

When the first or last image in the folder is displayed, the following indicators appear on the screen.

: Moves to the previous folder.

: Moves to the next folder.

: Moves to both the previous and next folders.

Single screen

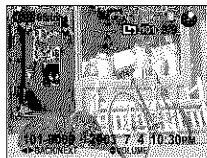

Index (nine-image) screen

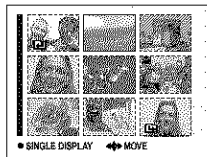

Index (triple-image) screen

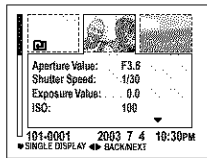

- When no images are stored in the folder, “No file in this folder” appears.
- You can play back images from a last-shot one without selecting the folder.

Enlarging a portion of a still image



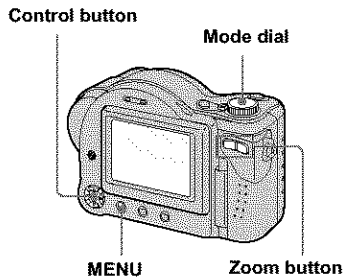

Mode dial: 

You can enlarge a part of an image up to five times the original size. You can also record the magnified image as a new file.





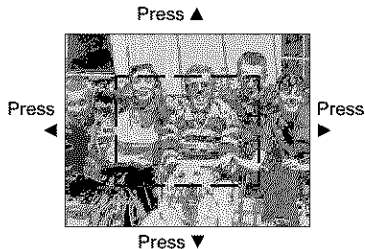

Enlarging an image

— Playback zoom

- 1 Set the mode dial to .
- 2 Display the image to be enlarged.
- 3 Press the zoom T button to zoom in on the image.
- 4 Select the desired portion of the image with ///.



- : To view more of the top of the image
- : To view more of the bottom of the image
- : To view more of the left side of the image
- : To view more of the right side of the image

- 5 Adjust the image size with the zoom W/T button.



To cancel playback zoom

Press .

- You cannot use playback zoom for movies (MPEG Movie), Clip Motion images and Multi Burst images.
- If you press the zoom W button while a non-enlarged image is displayed, the LCD screen switches to the index screen (page 32).
- You can enlarge the images displayed with the Quick Review function (page 24) by performing steps **3** to **5**.

Recording an enlarged image — Trimming

- 1 Press MENU after playback zoom.

The menu appears.

- 2 Select [Trimming] with \blacktriangleright , then press \bullet .

- 3 Select the image size with $\blacktriangle/\blacktriangledown$, then press \bullet .

The image is recorded, and the image on the screen returns to the normal size after recording.

- The trimmed image is recorded as the newest file in the selected recording folder, and the original image is retained.
- The quality of trimmed images may deteriorate.
- You cannot trim to an image size of 3:2.
- You cannot trim uncompressed (HFI) images.
- You cannot trim images displayed with Quick Review.
- If you trim an image, the disc remaining space will decrease.
- If the disc remaining space is not sufficient, you may not be able to trim an image.

Playing back successive images

— Slide Show

Mode dial: \blacktriangleright

You can play back recorded images in order. This function is useful for checking your images or for presentations, etc.

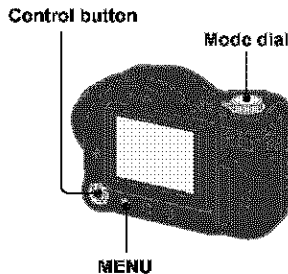

- 1 Set the mode dial to \blacktriangleright .

- 2 Press MENU.

The menu appears.

- 3 Select [Slide] with $\blacktriangle/\blacktriangleright$, then press \bullet .

Set the following items with $\blacktriangle/\blacktriangledown/\blacktriangle/\blacktriangleright$.

Interval

5 sec/10 sec/30 sec/1 min

Image

Folder:

Plays back all images in the selected folder.

All: Plays back all images stored in the disc.

Repeat

On: Plays back images in a continuous loop (approx. 20 min)*.

Off: After all the images have been played back, the slide show ends.

* The slide show does not end until all the images have been played back, even if the playback time exceeds 20 minutes.

- 4 Select [Start] with $\blacktriangledown/\blacktriangleright$, then press \bullet .

The slide show begins.

To cancel the Slide Show setting

Select [Cancel] in step 3.

To stop slide show playback

Press ●, select [Exit] with ►, then press ● again.

To skip to the next/previous image during the slide show

Press ► (next) or ◀ (previous).

- The interval setting time is approximate, and may vary according to the playback image size.

Rotating still images

— Rotate

Mode dial: ►

You can rotate an image recorded in portrait orientation and display it in landscape orientation.



Control button

Mode dial

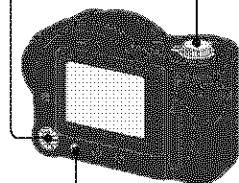

MENU

- 1 Set the mode dial to ►, and display the image to rotate.
- 2 Press MENU.
The menu appears.
- 3 Select [Rotate] with ►, then press ●.
- 4 Select ↶ ↷ with ▲, then rotate the image with ◀/▶.
- 5 Select [OK] with ▲/▼, then press ●.

To cancel rotation

Select [Cancel] in step 4 or 5, then press ●.

- You cannot rotate protected images and images recorded as movies (MPiG Movie), Clip Motion, Multi Burst and uncompressed (TIFF) images.
- You may not be able to rotate images shot with other cameras.
- When viewing images on a computer, the image rotation information may not be reflected depending on the application software.
- If you rotate an image, the disc remaining space will decrease.
- If the disc remaining space is not sufficient, you may not be able to rotate an image.

Playing back images shot in Multi Burst mode

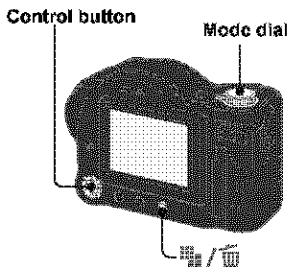

Mode dial: 

You can play back Multi Burst images continuously or play them back frame by frame. This function is used for checking the image.



- When Multi Burst images are played back on a computer or on a camera without the Multi Burst function, the 16 frames you shot will be displayed at the same time as part of one image.



Playing back continuously

- 1 Set the mode dial to .
- 2 Select the Multi Burst image with .

The selected Multi Burst image is played back continuously.





To pause playback

Press . To resume playback, press  again. The playback starts from the frame displayed on the LCD screen.





Playing back frame by frame

— Jog playback

- 1 Set the mode dial to .
- 2 Select the Multi Burst image with .
- 3 Press  when the desired frame is displayed.

“Stop” appears.





- 4 Advance the frame with .
- : A next frame is displayed. When you keep and press , the frame advances.
- : A previous frame is displayed. When you keep and press , the frame advances in the reverse direction.

To return to the normal playback

Press **●** in step **4**. The playback starts from the frame displayed on the LCD screen.

To delete shot images

When using this mode, you cannot delete only certain frames. When you delete images, all 16 of the frames are deleted at the same time.

- 1 Display the desired Multi Burst image to delete.
- 2 Press  /  (Delete).
- 3 Select [Delete], then press **●**.
All of the frames are deleted.

Protecting images

— Protect





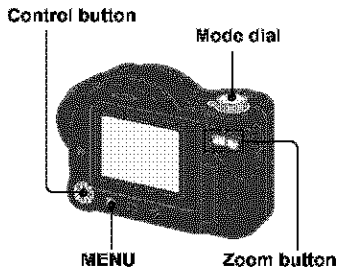

Mode dial: 

This function protects images against accidental erasure.





- If you protect an image, the disc remaining space will decrease. If you cancel the protection, the disc remaining space will also decrease.
- If the disc remaining space is not sufficient, you may not be able to protect an image.
- It may take some time to protect the images.

In single-image mode

- 1 Set the mode dial to .
- 2 Display the image you want to protect with / .
- 3 Press MENU.
The menu appears.
- 4 Select [Protect] with / , then press .

The displayed image is protected. The  (protect) indicator appears on the image.















- 5 To continue and protect other images, select the desired image with / , then press .

To cancel the protection

Press  again in step **4** or **5**. The  indicator disappears.

In index (nine-image) mode

- 1 Set the mode dial to , then press the zoom W (index) to display the index (nine-image) screen.
- 2 Press MENU.
The menu appears.
- 3 Select [Protect] with / , then press .
- 4 Select [Select] with / , then press .
- 5 Select the image you want to protect with / / / , then press .

The green  indicator appears on the selected image.

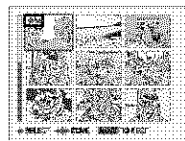

- 6 Repeat step **5** to protect other images.

7 Press MENU.

8 Select [OK] with **▶**, then press **●**.

The **○** indicator turns white. The selected images are protected.

To exit the Protect function

Select [Cancel] in step **4** or select [Exit] in step **8**, then press **●**.

To cancel individual protection

Select the image to be unprotected with **▲/▼/◀/▶**, then press **●** in step **5**. The **○** indicator turns gray. Repeat this operation for all images that are to be unprotected. Press MENU, select [OK], and then press **●**.

To protect all images in the folder

Select [All In Folder] in step **4**, and press **●**. Select [On], then press **●**.

To cancel all protection of all images in the folder

Select [All In Folder] in step **4**, and press **●**. Select [Off], then press **●**.

In index (triple-image) mode

1 Set the mode dial to **▶**, then press the zoom **W** (index) twice to display the index (triple-image) screen.

2 Display the image you want to protect in the center position with **◀/▶**.

3 Press MENU.

The menu appears.

4 Select [Protect] with **▲/▼**, then press **●**.

The center image is protected. The **○** indicator appears on the image.

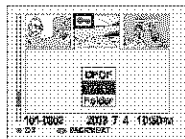

5 To protect other images, display the image you want to protect in the center position with **◀/▶**, and repeat step **4**.

To cancel previously set protection

Select the image to be unprotected, and press **●** in step **4**. To cancel protection of all images, repeat this process for each image.

Changing image size

— Resize

Mode dial: ►

You can change the image size of a recorded image, and save it as a new file. You can resize to the following sizes: 3.1M, 2.0M, 1.2M, VGA. The original image is retained even after resizing.

Control button

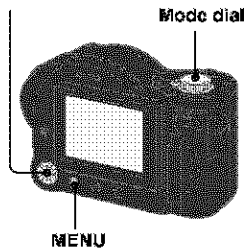

1 Set the mode dial to ►.

2 Display the image you want to resize with ◀/▶.

3 Press MENU.

The menu appears.

4 Select [Resize] with ◀/▶, then press ●.

5 Select the desired size with ▲/▼, then press ●.

The resized image is recorded in the recording folder as the newest file.

To cancel resizing

Select [Cancel] in step 5.

- You cannot change the size of movies (MPiG Movie), Clip Motion, Multi Burst or uncompressed (H1) images.
- When you change from a small size to a large size, the image quality deteriorates.
- You cannot resize to an image size of 3:2.
- When you resize a 3:2 image, the upper and lower black portions will be displayed on the image.
- If you resize an image, the disc remaining space will decrease.
- If the disc remaining space is not sufficient, you may not be able to resize an image.

Choosing images to print

— Print (DPOF) mark

Mode dial: ►

You can mark still images shot with your camera that you want to have printed. This function is convenient when you have images printed at a shop or using a printer that conforms with the DPOF (Digital Print Order Format) standard.



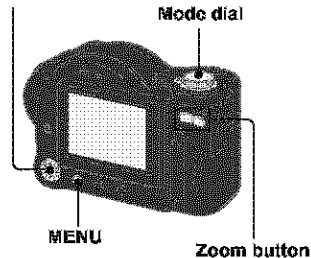



Control button



- You cannot mark movies (MPiG Movie) or Clip Motion images.
- In 16:9 mode, a print (DPOF) mark is marked on the normal size image that is recorded at the same time.
- When you mark images shot in Multi Burst mode, all the images are printed on one image divided into 16 frames.



- If you mark an image shot in TIFF mode with a print (DPOF) mark, only the uncompressed (TIFF) image is printed, and the JPEG image recorded at the same time is not printed.
- If you mark an image with a print mark, the disc remaining space will decrease. If you unmark the print mark, the disc remaining space will also decrease.
- If the disc remaining space is not sufficient, you may not be able to mark an image with a print mark.
- Make sure to finalize the disc before having images printed at a shop that supports the DPOF standard (page 75).

In single-image mode

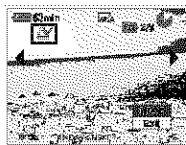

- 1** Set the mode dial to .
- 2** Display the image you want to mark with / .
- 3** Press MENU.
- 4** Select [DPOF] with / , then press .

The  mark is marked on the displayed image.









- 5** To continue and mark other images, display the desired image with / , then press .

To unmark the mark

Press  again in step **4** or **5**. The  mark disappears.

In index (nine-image) mode

- 1** Set the mode dial to , then press the zoom W (index) to display the index (nine-image) screen.
- 2** Press MENU.
- 3** Select [DPOF] with , then press .
- 4** Select [Select] with / , then press .

- When marking  marks, you cannot select [All In Folder].

- 5** Select the image you want to mark with / / / , then press .

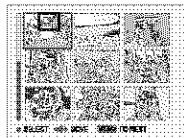

The green  mark appears on the selected image.



- 6** Repeat step **5** to mark other images.

7 Press MENU.

8 Select [OK] with **▶**, then press **●**.

The  mark turns white. The  mark setting is completed.

To unmark marks

Select the images to be unmarked in step **5**, then press **●**.

To unmark all the marks in the folder

Select [All In Folder] in step **4**, then press **●**. Select [Off], then press **●**.

To exit the mark function

Select [Cancel] in step **4**, or select [Exit] in step **8**.

In index (triple-image) mode

1 Set the mode dial to **▶**, then press the zoom **W** (index) twice to display the index (triple-image) screen.

2 Display the image you want to mark in the center position with **◀/▶**.

3 Press MENU.

The menu appears.

4 Select [DPOF] with **▲**, then press **●**.

The  mark is marked on the center image.

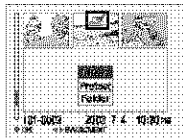

5 To continue and mark other images, display the image you want to print in the center position with **◀/▶**, and repeat step **4**.

To unmark the mark

Press **●** again in step **4**. The  mark disappears. Repeat this operation for all the images you want to unmark.

Shooting movies

Mode dial: 



You can shoot movies with sound (MPEG movies) using your camera.

Before starting

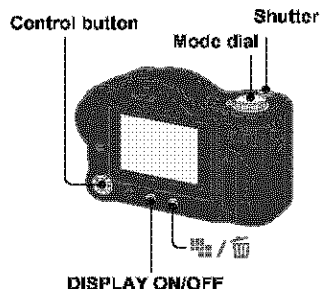
Set [Moving Image] to [MPEG Movie] in the SET UP settings (pages 40 and 105).



1 Set the mode dial to .

2 Press  /  (Image Size).
The Image Size setup appears.

3 Select the desired size with **▲**/**▼**.

You can choose from 640 (VGA), 160 (Mail).

For details on the recording time for each image size, see page 100.

4 Press the shutter button fully down.

"REC" appears on the screen and the camera starts recording the image and sound.



• Recording stops when the disc is full.

5 Press the shutter button fully down again to stop recording.

Indicators during shooting

The screen indicators are not recorded. Each time you press DISPLAY ON/OFF, the status of the LCD screen changes as follows: Indicators off → All indicators on. For a detailed description of the indicators, see page 114.

Shooting close-ups (Macro)

Set the mode dial to  and follow the procedure on page 25.

Using the self-timer

Set the mode dial to  and follow the procedure on page 26.

- Do not touch the microphone during shooting movies.
- You cannot use the flash.
- The date and time are not superimposed onto movies.

Viewing movies on the LCD screen

Mode dial:

You can view movies on the LCD screen with sound from the speaker.

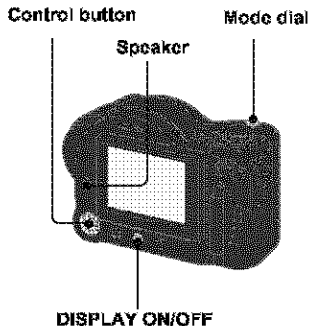

1 Set the mode dial to

2 Select the desired movie with .

Movies with the image size [160 (Mail)] are displayed a size smaller.

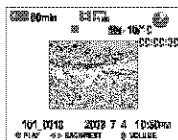

• Movies with the image size [640 (VGA)] are displayed on the full screen.

3 Press .

The movie and sound are played back. During playback, (Playback) appears on the screen.

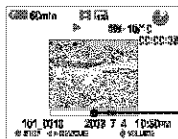

Playback bar

To stop playback

Press again.

To adjust the volume

Press / to adjust the volume.

To advance or rewind the movie

Press / during playback.

To return to the normal playback, press .

Indicators during viewing movies

Each time you press DISPLAY ON/OFF, the status of the screen changes as follows:

Indicators off → All indicators on.

For a detailed description of the indicators, see page 115.

- The procedure for viewing movies on a TV is the same as that for viewing still images (page 33).
- The movies recorded using earlier Sony models may be also displayed a size smaller.



Deleting movies

— Delete



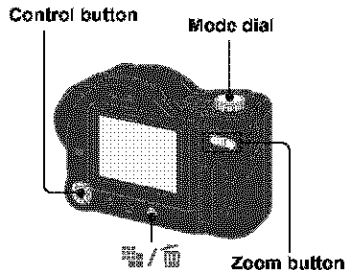





Mode dial: 

You can delete unwanted movies.



- When using a CD-R, the disc remaining space does not increase even if you delete images.
- When using a CD-RW, the disc remaining space only increases if you delete the last image you shot while  is indicated on the LCD screen. If you modify an image, or open and close the disc cover,  disappears.
- If the disc remaining space is not sufficient, you may not be able to delete an image.









In single-image mode

- 1** Set the mode dial to .
- 2** Display the movie you want to delete with / .
- 3** Press  /  (Delete).
The movie has not yet been deleted at this point.
- 4** Select [Delete] with , then press .
- When the message "Disc access" disappears, the movie has been deleted.
- 5** To continue and delete other movies, display the movie you want to delete with / , and repeat step **4**.

To cancel deletion

Select [Exit] in step **4** or **5**, then press .

In index (nine-image) mode

- 1** Set the mode dial to , then press the zoom W (index) to display an index (nine-image) screen.
- 2** Press  /  (Delete).
- 3** Select [Select] with , then press .
- 4** Select the movie you want to delete with / / , then press .

The green  (Delete) indicator appears on the selected movie.

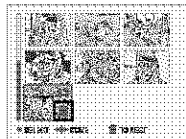

The movie has not yet been deleted at this point.

- 5** Repeat step **4** to delete other movies.
- 6** Press  /  (Delete).

- 7** Select [OK] with **▶**, then press **●**.

When the message “Disc access” disappears, the movies have been deleted.

To cancel deletion

Select [Exit] in step **6** or **7**.

To delete all movies in the folder

Select [All In Folder] in step **3**, then press **●**. To cancel deletion, select [Cancel] with **◀**, then press **●**.

In index (triple-image) mode

- 1** Set the mode dial to **▶**, then press zoom **W** (index) twice to display an index (triple-image) screen.
- 2** Display the movie you want to delete in the center position with **◀/▶**.
- 3** Press **⏏/🗑** (Delete).

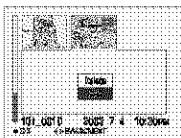

The movie has not yet been deleted at this point.

- 4** Select [Delete] with **▲**, then press **●**.

When the message “Disc access” disappears, the middle-positioned movie has been deleted.

To cancel deletion

Select [Exit] in step **4**, then press **●**.

Viewing images on your computer

— Introduction

There are two methods for viewing images on a computer.

- Viewing images using a CD-ROM drive (Windows only) (page 75).
- Copying images into your computer through a USB connection (Windows, Mac OS X only) (pages 81 and 87).

Recommended computer environment

■ Recommended Windows environment

OS: Microsoft Windows 98, Windows 98SE, Windows 2000, Windows 2000 Professional, Windows Millennium Edition, Windows XP Home Edition or Windows XP Professional

The above OS must be installed at the factory. Operation is not assured in an environment upgraded to the operating systems described above or in a multi-boot environment.

CPU: MMX Pentium 300 MHz or faster

USB connector: Provided as standard

Display: 800 × 600 dots or more

High Capacity Printer: 65,000 copies or more

■ Recommended Macintosh environment

OS: Mac OS X v. 10.0, 10.1, 10.2

Opt. USB connector: as possible

You cannot view the contents of images using the CD-ROM drive.

USB connector: Provided as standard

Display: 800 × 600 dots or more

12,000-dot or more or more

- If you connect two or more DVI-E equipment to a single output of the video time base equipment, including your camera, do not operate depending on the type of DVI-E equipment.
- Graphics may not be generated when using a USB hub.
- Graphics may not be generated correctly by recommended computer environment mentioned above.

Communication with your computer

When your computer is away from the camera, wireless remote communication between your camera and your computer may not proceed at the same time.

When a USB connector is not provided on your computer

You can copy images using a CD-ROM drive. Install the disc beforehand (Windows only).

Viewing images using CD-ROM drive

Finalizing a disc

You must execute finalization before viewing images recorded with your camera through a CD-ROM drive. Discs that have not been finalized cannot be read with a CD-ROM drive.

What is finalization?



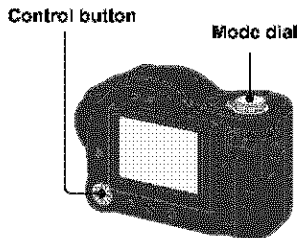

- Finalization is required to view images recorded with your camera through a CD-ROM drive.
- You can record new images on a finalized disc by initializing it again. Initialization is automatically performed when a disc is finalized using the camera. You must execute finalization to view new images through a CD-ROM drive. However, each time you execute finalization, the disc remaining space will decrease by approximately 13 MB. Therefore, we recommend that you execute finalization for multiple images at a time.
- You can finalize a disc later, even if you remove it from the camera.
- The CD-ROM drive must support MultiRead in order to read discs that have been finalized.





- 1 Set the mode dial to SET UP, and turn on the power.

The SET UP screen appears on the LCD screen.

- During finalization, we recommend using the AC Adaptor to prevent the power from turning off partway.

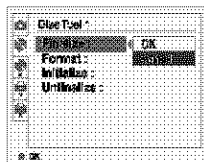

- 2 Select  (Disc Tool 1) with  on the control button, then press . Select [Finalize] with , then press .

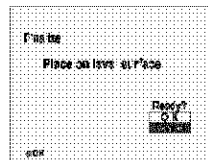

- 3 Select [OK] with  on the control button, then press .







"Finalize Place on level surface" appears on the LCD screen.

- 4 Select [OK] again with  on the control button, then press .



When "Finalize in progress" disappears, finalization has been completed.

Finalization starts and the disc remaining indicator changes from  to , or from  to . Finalization may take some time. Place the camera on a stable surface, and do not shake or strike the camera during finalization.

To cancel finalization

Select [Cancel] with ▼ on the control button in step 3 or 4, then press ●. Once finalization starts, you cannot cancel it.

Canceling finalization (Unfinalize) (CD-RW only)

- 1 Place the CD-RW you want to unfinalize in the disc tray. Set the mode dial to 📷.



“Unfinalize Place on level surface” appears on the LCD screen.

- You can also carry out this operation when the mode dial is set to 📷P, SCN or 📷.
- You can cancel the last-executed finalization (unfinalization). Once canceled, the disc space used for that finalization is recovered.

- 2 Select [OK] with ▲ on the control button, then press ●.

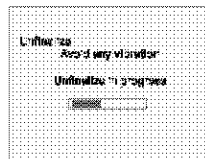

When “Unfinalizes in progress” disappears, unfinalization has been completed.

Unfinalization starts and the disc remaining indicator changes from 📷 to 📷.

Unfinalization may take some time. Place the camera on a stable surface, and do not shake or strike the camera during unfinalization.

To cancel the unfinalization

Select [Cancel] with ▼ on the control button in step 1, then press ●.

To unfinalize again after canceling the unfinalization

Set the mode dial to SET UP, then select [Unfinalize] under 📷 (Disc Tool 1) in the SET UP settings (pages 40 and 105).

- You cannot execute unfinalization when you record a new image or edit an image on a CD-RW after executing finalization.

Using the supplied 8cm CD adapter

- 1 Slide the disc into the inner groove and under two of the tabs on the inner circle of the adaptor in the order shown by the numbers.

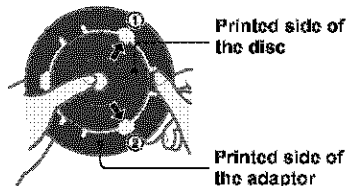

If your CD-ROM drive does not support 8 cm CD, use the supplied 8 cm CD adapter.

- The supplied adaptor may not be compatible with your CD-ROM drive. For details, see the operating instructions for the CD-ROM drive.
- The reverse side of the disc is the recordable surface.
- "SONY" is printed on the reverse side of the adaptor and the surface is lustrous.

- 2 Pull the third tab to the outside and slip the disc into place. Release the third tab and the disc will be held firmly in place.

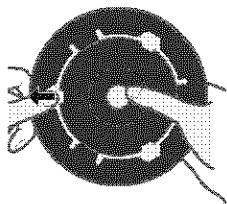

- Do not expose the adaptor to direct sunlight or heat sources.
- The adaptor can be used only with Maxide discs. It cannot be used with other 8 cm CD-R/CD-RW.

- 3 Check that the disc is set correctly in the grooves of the adaptor, all the tabs are even with the surface of the adaptor, and the disc does not protrude from the adaptor.

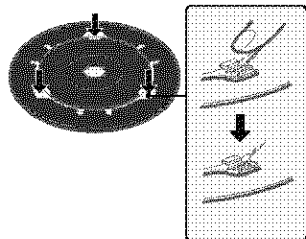

- If the tabs protrude, press them into place, as this may cause your CD-ROM drive to malfunction.

Viewing images through a CD-ROM drive

— Windows 98/98SE/2000/Me/XP

- 1 Start up your computer and insert a finalized disc into the CD-ROM drive of your computer.

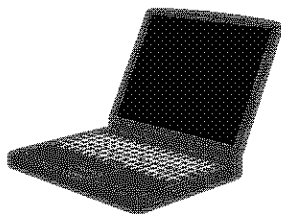

- To view images on a CD-RW using a CD-ROM drive, the drive must support MultiRead. Consult the drive manufacturer as to whether your drive supports MultiRead.
- This section describes how to view images through a CD-ROM drive using Windows Me as an example. The required operations may differ depending on your OS.
- You can use the "ImageMixer Ver. 1.5 for Sony" software to view images on your computer. For details, see page 83.

- 2 Open [My Computer] and double-click the drive you use for the disc (Example:[MV_20030101(E:)]).



- 3 Double-click "DCIM," then double-click the folder containing the image file you want to view.

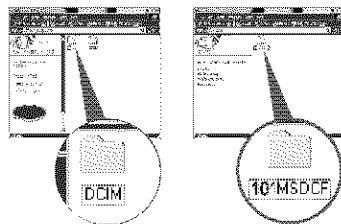

The folder contents are displayed.

- 4 Double-click the desired image file.

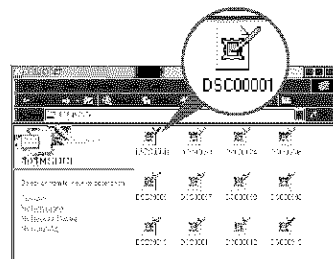

The file opens.

- Copying a file to the hard disk of your computer before viewing it is recommended. If you play back the file directly from the disc, the image and sound may break off.

Image file storage destinations and image file names

Image files recorded with your camera are grouped as folders in the disc.

Example: For Windows Me users

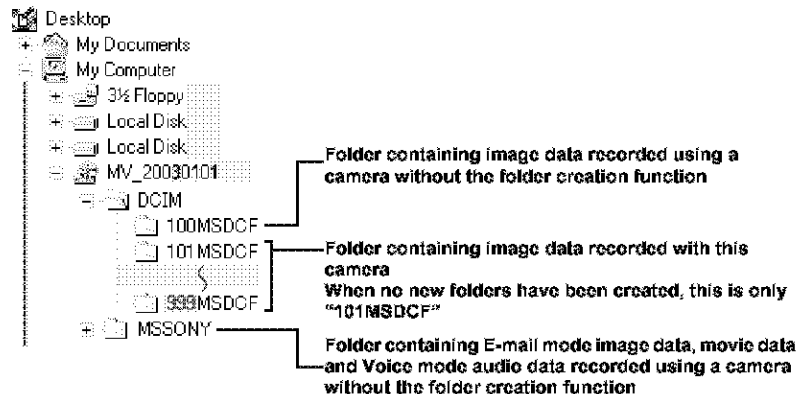

- Data in the "100MSDCF" or "MSSONY" folders is for playback only, and your camera cannot record images in these folders.
- For more information about the folder, see page 41.

Folder	File name	File meaning
101MSDCF up to 999MSDCF	DSC0□□□□.JPG	<ul style="list-style-type: none"> • Still image files shot in Normal mode • Burst 2 mode (page 52) • Image files shot in Multi Burst mode (page 51) • Still image files recorded simultaneously in E-Mail mode (page 53) • TIFF mode (page 53) • Voice mode (page 54)
	DSC0□□□□.JPE	• Small-size image files shot in E-Mail mode (page 53)
	DSC0□□□□.MPG	• Audio files shot in Voice mode (page 54)
	DSC0□□□□.TIFF	• Uncompressed (TIFF) image file recorded in TIFF mode (page 53)
	CLP0□□□□.GIF	• Clip Motion files shot in Normal mode (page 50)
	CLP0□□□□.THM	• Index image files of Clip Motion files shot in Normal mode
	MBL0□□□□.GIF	• Clip Motion files shot in Mobile mode (page 50)
	MBL0□□□□.THM	• Index image files of Clip Motion files shot in Mobile mode
	MOV0□□□□.MPG	• Movie files shot in MPEG Movie mode (page 70)

- □□□□ stands for any number within the range from 0001 to 9999.
- The numerical portions of the following files are the same.
 - A small-size image file shot in E-Mail mode and its corresponding image file
 - An audio file shot in Voice mode and its corresponding image file
 - An uncompressed image file shot in TIFF mode and its corresponding image file
 - An image file shot with Clip Motion and its corresponding index image file

Copying images into your computer through a USB connection

- Close down all applications running on the computer before installing.
- When using Windows 2000 or XP, log on as Administrator.



Installing the PTP Manager

— Windows 98/98SE/2000/Me

- When using Windows XP, you need not install the PTP Manager.
- Once the PTP Manager is installed, you need not install the PTP Manager again.

- 1 Start up your computer, and insert the supplied CD-ROM into the CD-ROM drive.

Do not connect your camera to your computer at this time.

The model selection screen appears. If it does not appear, double-click  (My Computer) →  (ImageMixer) in that order.

- 2 Click [CD Mavica] on the model selection screen.



The installing menu screen appears.

- 3 Click [PTP Manager USB Driver] on the installing menu screen.

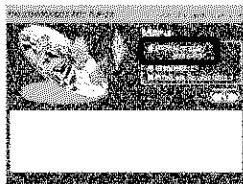

The “Choose Setup Language” screen appears.

- 4 Select the desired language then click [OK].



“Welcome to the InstallShield Wizard for PTP Manager” screen appears.

- This section describes the English screen.

- 5 Click [Next].



“Choose Destination Location” screen appears.

- 6** Select the destination folder, then click [Next].



“Select Program Folder” screen appears.

- 7** Select [PTP Manager] as a program folder, then click [Next].



“Start Copying Files” screen appears.

- 8** Check the settings and click [Next].



The PTP Manager installation starts. When installation finishes, “InstallShield Wizard Complete” screen appears.

- 9** Click [Finish].



- 10** Select “Yes, I want to restart my computer now,” then click [Finish].



The computer turns off and then immediately on again (restart).

Installing "ImageMixer"

— Windows 98/98SE/2000/Me/XP

You can use the "ImageMixer Ver. 1.5 for Sony" software to copy, view and edit images. For details, see the software's help files.

- 1 Click [ImageMixer] on the installing menu screen. Select the desired language, then click [OK].

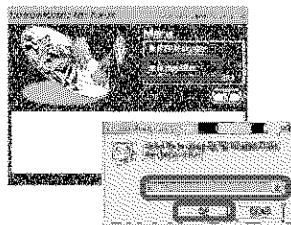

The "Welcome to the InstallShield Wizard" screen appears.

- This section describes the English screen.

- 2 Follow instructions on each succeeding screen.

Install "ImageMixer" according to the screen.

- When you use Windows 2000 or Windows XP, install "WinASPI."
 - If DirectX8.0a or a later version is not installed in your computer, the "Information" screen appears. Follow the procedure on the screen to install.
- 3 Restart your computer according to the screen.
 - 4 Remove the CD-ROM.

Connecting the camera to your computer

- 1 Insert the disc with the images you want to copy into the camera. Connect the power cord to the AC Adaptor (supplied) and then to a wall outlet.

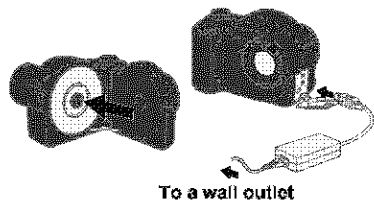

- For further details on the AC Adaptor, see page 14.
- For further details on the disc, see page 18.

- 2** Turn on your computer and the camera.

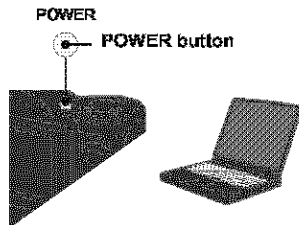

- 3** Connect the supplied USB cable to the Ψ (USB) jack of the camera.

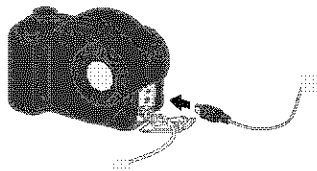

- 4** Connect the USB cable to your computer.

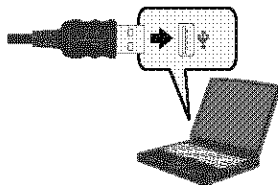

- When you use a desktop computer, we recommend that you connect the USB cable to the USB connector on the rear panel.
- When using Windows XP, the AutoPlay wizard automatically appears on the desktop. Proceed to page 86.

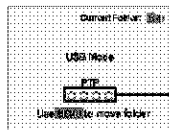

Access indicators*

"USB Mode PTP" appears on the LCD screen of the camera.

- * During communication, the access indicators turn red.

It may take some time for your computer to recognize the disc.

⚠ Disconnecting the USB cable from your computer or removing the disc from your camera during USB connection

Windows 98/98SE/2000/9x Users

1. Click [Start] and close the window when using the PTP Manager.
2. Disconnect the USB cable from the port on the computer, or remove the disc.

Copying images

- 1 Follow the steps on page 83 to make the USB connection, then the FTP Manager starts. Click [Next].



The images stored on the disc are displayed. It may take some time to load the images from the disc.

- 2 Select the images that you want to copy, then click [Next].

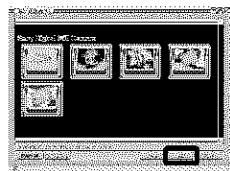

The Copy Destination and Group Name Setup screen appears. The images in the selected recording folder appear.

To copy an image in a different folder, follow the procedure on page 41 and change the recording folder.

- 3 Specify the image group names to be copied and the copy destination, then click [Next].



Image copying starts. When the copying is completed, the copying completed message appears.

- The images are copied into the "My Documents" folder as an example.

- 4 Click [Finish].

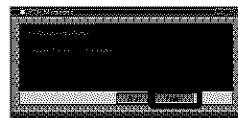





The Explorer starts up and the copy destination folder opens.



The images are copied to the copy destination folder.

When the PTP Manager does not start up

- 1 Right-click [My Computer], then click [Properties].
The “System Properties” screen appears.
 - When using Windows 2000, click [Hardware] tab on the “System Properties” screen.
- 2 Check whether the other device is already installed.
 - ① Click [Device Manager].
 - ② Check for a  Sony PTP with a  mark.
- 3 If the device is installed, remove it.
 - ① Click  Sony PTP].
(When using Windows 2000, right-click  Sony PTP].)
 - ② Click [Remove] (or [Uninstall] in Windows 2000).
The “Confirm Device Removal” screen appears.
 - ③ Click [OK].
The device is deleted.

Try PTP Manager installation again using the supplied CD-ROM (page 81).

Copying images using the Windows XP AutoPlay Wizard

— Windows XP

- 1 **Make a USB connection (page 83).**
The “Scanner and Camera Wizard” screen appears.
- 2 **Click [Next].**
The images stored on the disc are displayed.
- 3 **Click the checkbox of images that you do not want to copy to your computer and remove the checkmark, then click [Next].**
The “Picture Name and Destination” screen appears.
- 4 **Select a name and destination for your pictures, then click [Next].**
Image copying starts. When copying is completed, the “Other Options” screen appears.

- 5 **Select [Nothing, I'm finished working with these pictures], then click [Next].**

The “Completing the Scanner and Camera Wizard” screen appears.

- 6 **Click [Finish].**
The wizard closes.

Viewing images on your computer

1 Double-click [My Documents] on the desktop.

The “My Documents” folder contents are displayed.

2 Double-click the desired folder and image file.

The image is displayed.

- This section describes the procedure for viewing copied images in the “My Documents” folder.
- When using Windows XP, double-click [Start] → [My Documents] in that order.
- You can use the “ImageMixer Ver. 1.5 for Sony” software to view and edit images on your computer. For details, see the software’s help files.

Creating a Video CD

You can create Video CDs using commercially available 12 cm CD-R. For details, see the “ImageMixer” help files.

For Mac OS X (v10.0/v10.1/v10.2) users

Only Mac OS X users can view images using a USB connection.

1 Prepare your camera and computer.

For details, see page 83.

2 Connect your camera to your computer with the USB cable.

For details, see page 84.

3 Copy the images to your computer using “Image Capture.”

The “Image Capture” starts automatically. Copy the images following the on-screen directions.

- You may not be able to copy movie files.

Troubleshooting

If you experience trouble with your camera, try the following solutions.

- 1 First check the items on the tables below.
If code displays "C:□□:□□" appear on the screen, the self-diagnosis display function is working (page 98).

- 2 Should your camera still not work properly, press the RESET button on the bottom of the camera using a fine-tipped object, then turn on the power again. (All the settings including date and time are cleared.)

RESET button

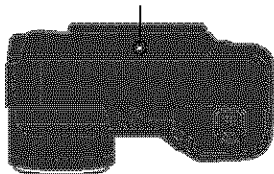

- 3 Should your camera still not work properly, consult your Sony dealer or local authorized Sony service facility.

Battery pack and power

Symptom	Cause	Solution
You cannot charge the battery pack.	<ul style="list-style-type: none"> • The camera is turned on. 	→ Turn the camera off (page 15).
The battery pack cannot be installed.	<ul style="list-style-type: none"> • The battery pack is not installed correctly. 	→ Install the battery pack while pushing the battery eject lever outward using the front edge of the battery pack (page 11).
The $\frac{1}{2}$ /CHG lamp flashes when charging a battery pack.	<ul style="list-style-type: none"> • The battery pack is not installed correctly. • The battery pack has malfunctioned. 	<ul style="list-style-type: none"> → Install the battery pack correctly (page 11). → Consult your Sony dealer or local authorized Sony service facility.
The $\frac{1}{2}$ /CHG lamp does not light up when charging a battery pack.	<ul style="list-style-type: none"> • The AC Adaptor is disconnected. • The battery pack is not installed correctly. • The battery pack is completely charged. 	<ul style="list-style-type: none"> → Properly connect the AC Adaptor (page 12). → Install the battery pack correctly (page 11). —



Symptom	Cause	Solution
The battery remaining indicator is incorrect, or sufficient battery remaining indicator is displayed but the power runs out soon.	<ul style="list-style-type: none"> You have used the camera for a long time in an extremely hot or an extremely cold location. The battery pack is dead (page 110). The battery pack is discharged. A deviation has occurred in the remaining battery time. 	<p>—</p> <ul style="list-style-type: none"> Replace the battery pack with a new one. Install a charged battery pack (page 11). Fully charge the battery pack (page 12).
The battery pack runs down too quickly.	<ul style="list-style-type: none"> You are shooting/viewing images in an extremely cold location. The battery pack is not charged enough. The battery pack is dead (page 110). 	<p>—</p> <ul style="list-style-type: none"> Charge the battery pack (page 11). Replace the battery pack with a new one.
You cannot turn on the camera.	<ul style="list-style-type: none"> The battery pack is not installed correctly. The AC Adaptor is disconnected. The battery pack is discharged. The battery pack is dead (page 110). 	<ul style="list-style-type: none"> Install the battery pack correctly (page 11). Properly connect the AC Adaptor (page 14). Install a charged battery pack (page 11). Replace the battery pack with a new one.
The power turns off suddenly.	<ul style="list-style-type: none"> If you do not operate the camera for about three minutes when using a battery pack, the camera turns off automatically to prevent wearing down the battery (page 15). The battery pack is discharged. 	<ul style="list-style-type: none"> Turn on the camera again (page 15) or use the AC Adaptor (page 14). Replace it with a charged battery pack (page 11).

Shooting still images/movies

Symptom	Cause	Solution
The subject is not visible on the screen.	<ul style="list-style-type: none"> The mode dial is not set to , , SCN or . 	→ Set it to , , SCN or (pages 22 and 70).
The image is out of focus.	<ul style="list-style-type: none"> The subject is too close. The (Twilight mode) or (Landscape mode) is selected for the Scene Selection function. The focus preset function is selected. 	→ Record in the macro recording mode. Make sure to position the lens farther away from the subject than the shortest shooting distance when shooting (page 25). → Set it to other modes (page 55). → Cancel the function (page 46).
Smart zoom does not function.	<ul style="list-style-type: none"> You cannot use smart zoom while shooting movies (MPKG Movie). [Smart Zoom] is set to [Off] in the SHUT UP settings. The image size is set to [3.1M] or [2.8M (3:2)]. 	— → Set [Smart Zoom] to [On] (pages 40 and 105). → Set the image size to other settings except [3.1M] and [2.8M (3:2)].
The image is too dark.	<ul style="list-style-type: none"> You are shooting a subject with a light source behind the subject. The brightness of the screen is too low. 	→ Adjust the exposure (page 46). → Adjust the brightness of the LCD screen (pages 40 and 106).
The image is too bright.	<ul style="list-style-type: none"> You are shooting a spotlighted subject in a dark location such as on a stage. The brightness of the LCD screen is too bright. 	→ Adjust the exposure (page 46). → Adjust the brightness of the LCD screen (pages 40 and 106).
The image is monochrome (black and white).	<ul style="list-style-type: none"> [PEFX] (P. Effect) in the menu settings is set to [B&W]. 	→ Cancel the B&W mode (page 57).
Vertical streaks appear when you are shooting a very bright subject.	<ul style="list-style-type: none"> The smear phenomenon is occurring. 	→ This is not a malfunction.
Noise appears in the image when you view the LCD screen in a dark place.	<ul style="list-style-type: none"> The camera is functioning to increase the visibility of the LCD screen by temporarily brightening the image under conditions of low illumination. 	→ There is no effect on the recorded image.

Symptom	Cause	Solution
Your camera cannot record images.	<ul style="list-style-type: none"> • No disc has been inserted. • The disc is full. • The disc has not been initialized. • You cannot record images while charging the flash. • The mode dial is not set to , or SCN when shooting a still image. • The mode dial is not set to when shooting a movie. 	<ul style="list-style-type: none"> → Insert a disc (page 18). → Replace it with a new one. Format the disc when using a CD-RW. → Initialize the disc (page 19). — → Set it to , , or SCN (page 22). → Set it to (page 70).
The flash does not work.	<ul style="list-style-type: none"> • The mode dial is not to , or (Clip Motion). • The flash is set to (No flash). • The (Twilight mode) is selected for the Scene Selection function. • (High-speed shutter mode), (Beach mode), (Snow mode) or (Landscape mode) is selected for the Scene Selection function. • [Moving Image] in the SET UP settings is set to [MPKG Movie] or [Multi Burst]. • [Mode] (RHC Mode) in the menu settings is set to [Burst 2]. 	<ul style="list-style-type: none"> → Set it to , or (Clip Motion) (pages 22 and 70). → Set the flash to Auto (No indicator) or (Forced flash) (page 27). → Set it to other settings (page 55). → Set the flash to (Forced flash) (page 27). → Set it to [Clip Motion]. → Set it to other settings.
The macro function does not work.	<ul style="list-style-type: none"> • The (Twilight mode) or (Landscape mode) is selected for the Scene Selection function. 	<ul style="list-style-type: none"> → Set it to other settings (page 55).
The eyes of the subject come out red.	—	<ul style="list-style-type: none"> → Set [Red Eye Reduction] in the SET UP settings to [On] (pages 28 and 105).
The date and time are recorded incorrectly.	<ul style="list-style-type: none"> • The date and time are not set correctly. 	<ul style="list-style-type: none"> → Set the correct date and time (page 16).
The F value and shutter speed flash when you press and hold the shutter button halfway down.	<ul style="list-style-type: none"> • The exposure is incorrect. 	<ul style="list-style-type: none"> → Correct the exposure (page 46).

Viewing images

Symptom	Cause	Solution
Your camera cannot play back images.	<ul style="list-style-type: none"> The mode dial is not set to . Your camera cannot play back image files copied from the hard disk of your computer if the folder/file name has been changed or the image has been modified. The camera is in USB mode. 	→ Set it to  (page 31). — → Cancel USB communication (page 84).
The image appears rough right after playback starts.	—	→ This is not a malfunction.
The image does not appear on the TV screen.	<ul style="list-style-type: none"> The video output signal setting of your camera in the SETUP settings is incorrect. The connection is not correct. 	→ Change the setting (pages 40 and 106). → Check the connection (page 33).
The image cannot be played back on a computer.	—	→ See page 93.
Unknown beeps are heard from the camera while viewing a movie.	<ul style="list-style-type: none"> These beeps are heard when the auto focus is working. 	→ This is not a malfunction. Shoot the image using the focus preset (page 46).

Deleting/Editing Images

Symptom	Cause	Solution
Your camera cannot delete an image.	<ul style="list-style-type: none"> The image is protected. The disc remaining space is not sufficient. 	→ Cancel the protection (page 65). → This is not a malfunction.
You have deleted an image by mistake.	<ul style="list-style-type: none"> Once you have deleted an image, you cannot restore it. 	→ Marking  (protect) will prevent you from deleting images by mistake (page 65).
The resizing function does not work.	<ul style="list-style-type: none"> You cannot resize movies (MPEG Movie), Clip Motion, Multi Burst and uncompressed (LIFE) images. The disc remaining space is not sufficient. 	— → This is not a malfunction.
You cannot display a print (DPOF) mark.	<ul style="list-style-type: none"> You cannot display print (DPOF) marks on movies and Clip Motion images. The disc remaining space is not sufficient. 	— → This is not a malfunction.

Computers

Symptom	Cause	Solution
You do not know if the OS of your computer is compatible.	—	→ Check “Recommended computer environment” (page 74).
You cannot install PTP Manager.	—	→ In Windows 2000, log on as Administrator (authorized Administrators) (page 81).
Your computer does not recognize your camera.	<ul style="list-style-type: none"> • The camera is turned off. • The battery level is low. • You are not using the supplied USB cable. • The USB cable is not connected firmly. • The camera was connected to a computer with the USB cable before installing PTP Manager, so the device was not recognized by the computer. • The USB connectors on your computer are connected to other equipment besides the keyboard, the mouse, and your camera. • PTP Manager is not installed. • The camera is not connected directly to your computer. 	<ul style="list-style-type: none"> → Turn on the camera (page 15). → Use the AC Adaptor (page 14). → Use the supplied USB cable (page 84). → Disconnect the USB cable, and connect it again firmly. Make sure that “USB Mode” is displayed on the screen (page 84). → Delete the device which is not recognized, then install PTP Manager (pages 86 and 81). → Disconnect the USB cables except for the ones connected to the keyboard, the mouse, and your camera. → Install PTP Manager (page 81). → Connect the camera directly to your computer without passing through a USB hub or other device.
You cannot copy images.	<ul style="list-style-type: none"> • The camera is not correctly connected to your computer. • You are not using the correct copy procedure for your OS. <p>—</p>	<ul style="list-style-type: none"> → Connect the camera and your computer correctly using the USB cable (page 83). → Follow the designated copy procedure for your OS (pages 85 and 87). → If you are using the “ImageMixer Ver. 1.5 for Sony” application software, click on H.H.I.P.
The image cannot be played back on a computer.	—	<ul style="list-style-type: none"> → If you are using the “ImageMixer Ver. 1.5 for Sony” application software, click on H.H.I.P. → Consult the computer or software manufacturer.

Symptom	Cause	Solution
The image cannot be played back through the CD-ROM drive of your computer.	<ul style="list-style-type: none"> • The disc has not been finalized. • Vibration caused an error during recording. • The CD-ROM drive does not support the packet-write system. • The CD-ROM drive does not support the MultiRead. • The disc may be scratched or dirty. — 	<ul style="list-style-type: none"> → Finalize the disc (page 75). → You may be able to view the image if you connect the camera to your computer with the USB cable. → Consult the computer or the CD-ROM drive manufacturer. → Consult the computer or the CD-ROM drive manufacturer. → Clean the disc if the disc is dirty. When the disc is scratched replace the disc. → Causes not described above have occurred, consult the computer or software manufacturer.
The image and sound are interrupted by noise when you view a movie on a computer.	<ul style="list-style-type: none"> • You are playing back the file directly from the disc. 	<ul style="list-style-type: none"> → Copy the file to the hard disk of your computer and then play back the file from the hard disk.
You cannot print an image.	<ul style="list-style-type: none"> — — 	<ul style="list-style-type: none"> → Check the printer settings. → Click on HELP for the "ImageMixer Ver. 1.5 for Sony" application software.
An error message appears when you set the supplied CD-ROM in your computer.	<ul style="list-style-type: none"> • The computer display is not set correctly. 	<ul style="list-style-type: none"> → Set the computer display as follows: Windows: 800 × 600 dots or more High Color (16 bits, 65,000 colors) or more Macintosh: 800 × 600 dots or more 32,000-color or more

Disc

Symptom	Cause	Solution
You cannot record on a disc.	<ul style="list-style-type: none"> • The disc is full. • The disc is not initialized. • The disc is not placed correctly. 	<ul style="list-style-type: none"> → Replace it with a new one. Format the disc when using a CD-RW. → Initialize the disc (page 19). → Place the disc correctly in the disc tray (page 18).



Others

Symptom	Cause	Solution
Your camera does not work.	<ul style="list-style-type: none">• You are not using an "InfoLITHIUM" battery pack.• The battery level is low. (The  indicator appears.)• The AC Adaptor is not connected securely.	<ul style="list-style-type: none">→ Use an "InfoLITHIUM" battery pack (page 109).→ Charge the battery pack (page 11).→ Connect it securely to the DC IN jack of your camera and to a wall outlet (page 14).
The power is on, but the camera does not work.	<ul style="list-style-type: none">• The built-in microcomputer is not working properly.	<ul style="list-style-type: none">→ Disconnect, and then, after one minute, reconnect all power sources and turn on the camera. If this does not work, press the RESET button on the bottom of the camera using a fine-tipped object, then turn on the power again. (All the settings including date and time are cleared.)
You cannot identify an indicator on the screen.	—	<ul style="list-style-type: none">→ Check the indicator (page 113).
The lens gets fogged.	<ul style="list-style-type: none">• Moisture condensation has occurred.	<ul style="list-style-type: none">→ Turn off the camera and leave for about an hour at room temperature for the moisture to evaporate before use (page 108).
A file error occurs when you play back a file.	<ul style="list-style-type: none">• The image file has an error.• The image was not recorded correctly.• The disc is dirty• The disc may be scratched.	<ul style="list-style-type: none">——→ Clean the disc (page 108).→ Replace the disc.

Warnings and messages

The following messages may appear on the screen.

Message	Meaning/Corrective action
Cover open	• The disc cover is open. Close the disc cover (page 18).
No disc	• No disc is inserted. Insert a disc (page 18).
Drive error	• Trouble has occurred with the drive. Turn the power off and on again (page 15).
System error	• Trouble has occurred with the drive or the camera. Turn the power off and on again (page 15).
Disc error	• The inserted disc cannot be used with your camera, is damaged, is dirty, or cannot be read due to vibration.
Dew error	• Moisture condensation has occurred inside the camera. Turn off the camera and wait for about an hour for the moisture to evaporate before use (page 108).
Disc protect	• The disc was protected with a computer, and cannot be recorded.
No file in this folder	• No images have been recorded in this folder.
Folder error	• A folder with the same first three digits number already exists in the disc. (For example: 123MSDCF and 123ABCDEF) Select other folders, or create a new folder.
Cannot create more folders	• The folder whose first three digits of the name is "999" exists in the disc. You cannot create any folders.
Not enough disc space	• The remaining disc space is insufficient for any operation other than finalization.
Not initialized	• The disc has not been initialized, so images cannot be recorded by the camera. Initialize the disc (page 19).
Already initialized	• The disc has already been initialized, so initialization is not necessary.
Already finalized	• The disc has already been finalized, so finalization is not necessary.
Cannot record	• The camera cannot record images in the selected folder. Select a different folder (page 41).
File error	• An error occurred while playing back the image.
Image size over	• You are playing back an image of a size larger than can be played back with your camera.
Invalid operation	• You are playing back a file that was created on equipment other than your camera.
File protect	• The image is protected against erasure. Release the protection (page 65).
For "InfoLITHIUM" battery only	• The battery is not the "InfoLITHIUM" type.

Message	Meaning/Corrective action
Not enough battery	<ul style="list-style-type: none"> The battery level is too low to execute initialization or finalization.
	<ul style="list-style-type: none"> The battery level is low. Charge the battery pack (page 11). Depending on the conditions of use, the indicator may flash even though there is still 5 to 10 minutes of remaining battery time left.
Can not unfinalize	<ul style="list-style-type: none"> A CD-R or disc that has not been finalized is inserted.
Can not format	<ul style="list-style-type: none"> A CD-R is inserted.
Format error	<ul style="list-style-type: none"> A disc formatted with equipment other than your camera is inserted. Format again with your camera (page 38).
Turn the power off and on again	<ul style="list-style-type: none"> A problem with the lens caused an error.
	<ul style="list-style-type: none"> The amount of light is not sufficient, so you are not holding the camera steady enough. Use the flash, or mount the camera on a tripod or otherwise secure the camera in place.

Self-diagnosis display

– If a code starting with an alphabet letter appears

Your camera has a self-diagnosis display. This function displays the camera condition on the LCD screen with a combination of a letter and four numerical digits. If this occurs, check the following code chart and attempt the corresponding corrective actions. The last two digits (indicated by □□) will differ depending on the state of the camera.

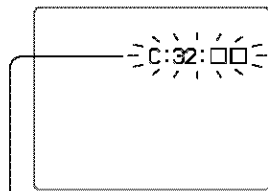

Self-diagnosis display

Code	Cause	Corrective action
C:32: □□	There is trouble with your camera's hardware.	• Turn the power off and on again (page 15).
C:13: □□	The camera cannot read or write data on the disc.	• Clean the disc when the disc is dirty (page 108).
	The inserted disc cannot be used with your camera, or the data is damaged.	• Insert a new disc (page 18).
E:61: □□ E:91: □□	A camera malfunction that you cannot reverse has occurred.	• Press the RESET button (page 88) located on the bottom of the camera, then turn on the power again.

If you are unable to solve the problem even after trying the corrective actions a few times, contact your Sony dealer or local authorized Sony service facility and inform them of the 5-digit code.

Number of images that can be saved or shooting time

In addition to setting the image size and image quality, you can also select various recording modes according to the purpose of shooting.

- The values for the number of images that can be saved and the shooting time may vary, depending on the shooting conditions.
- The numbers in the table indicate the number of images that can be recorded or the recordable time for the supplied CD-R disc.

Number of still images that can be saved

(Units: images)

Recording mode		Image size				
		3.1M	2.0M (3:2)	2.0M	1.2M	VGA
Normal	Standard	145	145	234	345	1285
	Fine	81	81	131	194	655
H-Mail	Standard	137	137	214	303	845
	Fine	79	79	124	180	518
TIFF	Standard	12	14	13	13	13
	Fine	11	13	12	12	13
Voice*	Standard	131	131	200	276	669
	Fine	77	77	119	170	446

* When recording sound for 5-second

Shooting time

(Units: images)

Recording mode	Image size				Image quality	
	640 (VGA)	160 (Mail)	Mobile	Normal	Standard	Fine
MPEG Movie	5 min. 51 sec.	89 min. 11 sec.	–	–	–	–
Clip Motion*	–	–	1070	505*	–	–
Multi Burst**	–	–	–	–	345	194

* When recording 10 frames per Clip Motion: file

**The image size is 1.2M.

Menu items

Menu items that can be modified differ depending on the position of the mode dial.





The screen shows only the items you can operate in each specific mode.

Factory settings are indicated with ■.

When the mode dial is set to

Item	Setting	Description
Mode (REC Mode)	TiFF Voice E-Mail Burst 2 ■ Normal	<ul style="list-style-type: none">– Records an uncompressed (TiFF) file in addition to the JPEG file (page 53).– Records an audio file (with a still image) in addition to the JPEG file (page 54).– Records a small-size (320×240) JPEG file in addition to the selected image size (page 53).– Records two images in succession (page 52).– Records an image using the normal recording mode.

When the mode dial is set to or















Item	Setting	Description
SCN		Sets the Scene Selection mode (page 55). (This setting can be made only in SCN mode.)
 (EV)	+2.0EV / +1.7EV / -1.3EV / +1.0EV / +0.7EV / +0.3EV / ■ 0EV / -0.3EV / -0.7EV / -1.0EV / -1.3EV / -1.7EV / -2.0EV	Adjusts the exposure (page 46).
 (Focus)	∞ / 7.0m / 3.0m / 1.0m / 0.5m / Center AF / ■ Multi AF	Chooses a focus range finder frame (page 43), or sets the focus preset distance (page 46).
 (Metering Mode)	Spot / ■ Multi	Adjusts the exposure to the subject you are shooting (page 47).
WB (White Bal)	WB /  / Auto	Sets the white balance (page 48).

Item	Setting	Description
ISO	400 / 200 / 100 / Auto	This selects the ISO sensitivity. Select a large number when shooting in dark locations or shooting a subject moving at high speed, or select a small number to obtain high image quality. (This setting cannot be made in SCN mode.)
(P.Quality)	Fine / Standard	Records images with fine/standard quality (page 41).
Mode (REC Mode)	TiFF Voice E-Mail Burst 2 Normal	<ul style="list-style-type: none"> - Records an uncompressed (TiFF) file in addition to the JPEG file (page 53). - Records an audio file (with a still image) in addition to the JPEG file (page 54). - Records a small-size (320x240) JPEG file in addition to the selected image size (page 53). - Records two images in succession (page 52). - Records an image using the normal recording mode.
(Flash Level)	High / Normal / Low	Selects the amount of flash light (page 49).
PFX (P.Effect)	Solarize / B&W / Sepia / Neg. Art / Off	Sets the image special effects (page 57).
(Sharpness)	+ / Normal / -	Adjusts the sharpness of the image. The indicator appears (except when the setting is Normal). (This setting cannot be made in SCN mode.)
(Saturation)	+ / Normal / -	Adjusts the saturation of the image. The indicator appears (except when the setting is Normal). (This setting cannot be made in SCN mode.)
(Contrast)	+ / Normal / -	Adjusts the contrast of the image. The indicator appears (except when the setting is Normal). (This setting cannot be made in SCN mode.)

















When the mode dial is set to (when [Moving Image] is set to [MPEG Movie] in the SET UP settings)

Item	Setting	Description
(EV)	+2.0EV / -1.7EV / +1.3EV / +1.0EV / +0.7EV / -0.3EV / 0EV / -0.3EV / -0.7EV / -1.0EV / -1.3EV / -1.7EV / -2.0EV	Adjusts the exposure (page 46).
(Focus)	∞ / 7.0m / 3.0m / 1.0m / 0.5m / Center AF / Multi AF	Chooses a focus range finder frame (page 43), or sets the focus preset distance (page 46).
(Metering Mode)	Spot / Multi	Adjusts the exposure to the subject you are shooting (page 47).
WB (White Bal)	WB / / / / / Auto	Sets the white balance (page 48).
PFX (P.Effect)	Solarize / B&W / Sepia / Neg. Art / Off	Sets the image special effects (page 57).



When the mode dial is set to (when [Moving Image] is set to [Clip Motion] in the SET UP settings)

Item	Setting	Description
 (EV)	+2.0EV / +1.7EV / -1.3EV / +1.0EV / +0.7EV / +0.3EV /  0EV / -0.3EV / -0.7EV / -1.0EV / -1.3EV / -1.7EV / -2.0EV	Adjusts the exposure (page 46).
 (Focus)	∞ / 7.0m / 3.0m / 1.0m / 0.5m / Center AF /  Multi AF	Chooses a focus range finder frame (page 43), or sets the focus preset distance (page 46).
 (Metering Mode)	Spot /  Multi	Adjusts the exposure to the subject you are shooting (page 47).
WB (White Bal)	 WB /  /  /  /  Auto	Sets the white balance (page 48).
 (Flash Level)	High /  Normal / Low	Selects the amount of flash light (page 49).
PFX (P.Effect)	Solarize / B&W / Sepia / Neg. Art /  Off	Sets the image special effects (page 57).

When the mode dial is set to (when [Moving Image] is set to [Multi Burst] in the SET UP settings)

Item	Setting	Description
 (EV)	+2.0EV / +1.7EV / -1.3EV / +1.0EV / +0.7EV / +0.3EV /  0EV / -0.3EV / -0.7EV / -1.0EV / -1.3EV / -1.7EV / -2.0EV	Adjusts the exposure (page 46).
 (Focus)	∞ / 7.0m / 3.0m / 1.0m / 0.5m / Center AF /  Multi AF	Chooses a focus range finder frame (page 43), or sets the focus preset distance (page 46).
 (Metering Mode)	Spot /  Multi	Adjusts the exposure to the subject you are shooting (page 47).
WB (White Bal)	 WB /  /  /  /  Auto	Sets the white balance (page 48).
 (Interval)	1/7.5 / 1/15 /  1/30 (NTSC) 1/6.3 / 1/12.5 /  1/25 (PAL)	<ul style="list-style-type: none"> - Selects the Multi Burst shutter interval in NTSC mode. - Selects the Multi Burst shutter interval in PAL mode. • The shutter interval settings differ depending on the setting of the [Video Out] item in the SET UP settings (page 106).
 (P.Quality)	 Fine / Standard	Records images with fine/standard quality (page 41).
PFX (P.Effect)	Solarize / B&W / Sepia / Neg. Art /  Off	Sets the image special effects (page 57).

When the mode dial is set to

Item	Setting	Description
Folder	OK / Cancel	Selects the folder containing the image you want to play back (page 59).
Protect	—	Protects images against accidental erasure (page 65).
DPOF	—	Marks the print (DPOF) mark on still images you want to print (page 67).
Slide	Interval Image Repeat Start Cancel	<ul style="list-style-type: none"> - Sets the slide show interval (page 61). (Only in single-image mode.) <ul style="list-style-type: none"> ■ 5 sec / 10 sec / 30 sec / 1 min - Sets the range of the playback images. <ul style="list-style-type: none"> ■ Folder / All - Plays back images repeatedly. <ul style="list-style-type: none"> ■ On / Off - Starts the slide show. - Cancels the slide show.
Resize	3.1M / 2.0M / 1.2M / VGA / Cancel	Changes the recorded still image size (page 67). (Only in single-image mode.)
Rotate	 (counter clockwise) /  (clockwise) / OK / Cancel	Rotates the still image (page 62). (Only in single-image mode.)

SET UP items

Set the mode dial to SET UP. The SET UP screen appears.

Factory settings are indicated with ■.

(Camera)

Item	Setting	Description
Moving Image	■MPRG Movie / Clip Motion / Multi Burst	Selects the shooting mode for a movie (pages 70, 50 and 51).
AF Mode	Single / ■Monitor / Cont	Selects the focus operation mode (page 44).
Smart Zoom	■On / Off	Selects whether to use the smart zoom (page 25).
Date/Time	Day & Time / Date / ■Off	Selects whether to superimpose the date or time onto the image (page 30). The date and time are not inserted in movie (MPRG Movie), Clip Motion or Multi Burst mode. Also, the date and time appear only during playback, and do not appear during recording.
Red Eye Reduction	On / ■Off	Reduces the red-eye phenomenon when using a flash (page 28).
AF Illuminator	■Auto / Off	Selects whether to emit AF illuminator light. Used when it is difficult to focus on the subject in dark conditions (page 28).

(Disc Tool 1)

Item	Setting	Description
Finalize	OK / Cancel	Finalizes a disc to allow viewing through a CD-ROM drive (page 75).
Format	OK / Cancel	Formats a CD-RW (page 38).
Initialize	OK / Cancel	Initializes a disc (page 19).
Unfinalize	OK / Cancel	Cancels the last executed finalization (page 76) (CD-RW only).

 (Disc Tool 2)

Item	Setting	Description
File Number	<input checked="" type="checkbox"/> Series Reset	<ul style="list-style-type: none">- Assigns numbers to files in sequence even if the disc is changed or the recording folder is changed.- Resets the file numbering and starts from 0001 each time the folder is changed. (When the recording folder contains a file, a number one higher than the largest number is assigned.)
Create REC. Folder	OK / Cancel	Creates a folder for recording images (page 42).
Change REC. Folder	OK / Cancel	Changes a folder for recording images (page 42).
Confirm B. Write	On / <input checked="" type="checkbox"/> Off	Selects whether to confirm recording or deletion of the image before writing to the disc (page 57).

 (Setup 1)

Item	Setting	Description
LCD Brightness	Bright / <input checked="" type="checkbox"/> Normal / Dark	Selects the LCD brightness. This has no effect on the recorded images.
LCD Backlight	Bright / <input checked="" type="checkbox"/> Normal	Selects the brightness of the LCD backlight. Selecting [Bright] makes the screen bright and easy to see when using the camera outdoors or in other bright locations, but also uses up the battery charge faster. Displayed only when using your camera with the battery pack.
Beep	Shutter <input checked="" type="checkbox"/> On Off	<ul style="list-style-type: none">- Turns on the shutter sound. (The shutter sound is heard when you press the shutter button.)- Turns on the beep/shutter sound when you press the control button/shutter button.- Turns off the beep/shutter sound.
<input checked="" type="checkbox"/> Language	—	Displays the menu items, warnings and messages in selected language.
Clock Set	OK / Cancel	Sets the date and time (pages 16 and 40).

 (Setup 2)

Item	Setting	Description
Video Out	NTSC PAL	<ul style="list-style-type: none">- Sets the video output signal to NTSC mode (e.g., USA, Japan).- Sets the video output signal to PAL mode (e.g., Europe).

Precautions

On handling the camera

Do not carry the camera by the disc cover



Do not touch the rotating disc

This may cause injury.

On cleaning the pickup lens

When the pickup lens becomes dirty and the camera cannot operate properly, clean the pickup lens using a commercially available blower.

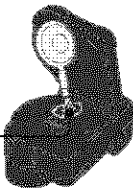

Pickup lens

On pickup lens

Do not touch the pickup lens inside the disc cover. Also, do not open the disc cover except when inserting or removing a disc in order to keep dust out.

Do not leave the camera in the following places

- In extremely hot place, such as in a car parked in the sun. The camera body may become deformed or this may cause a malfunction.
- Under direct sunlight or near a heater. The camera body may become deformed or this may cause a malfunction.
- On rocking vibration
- Near strong magnetic place
- In sandy or dusty places, be careful not to let sand or dust get into the camera. This may cause the camera to malfunction, and in some cases this malfunction cannot be repaired.

On cleaning

Cleaning the LCD screen

Wipe the screen surface with an LCD cleaning kit (not supplied) to remove fingerprints, dust, etc.

Cleaning the DC plug

Clean the DC plug of the AC Adaptor with a dry cotton bud. Do not use the dirty plug. Use of the dirty plug may not properly charge the battery pack.

Cleaning the lens

Wipe the lens with a soft cloth to remove fingerprints, dust, etc.

Cleaning the camera surface

Clean the camera surface with a soft cloth slightly moistened with water, then wipe the surface with a dry cloth. Do not use the following as this may damage the finish or the casing.

- Thinner
- Benzine
- Alcohol
- Disposable cloth
- Volatile insecticide
- Contact with rubber or vinyl for a long time

Note on operating temperature

Your camera is designed for use between the temperatures of 0°C and 40°C (32°F and 104°F). Shooting in extremely cold or hot places that exceed this range is not recommended.

On moisture condensation

If the camera is brought directly from a cold to a warm location, or is placed in a very damp room, moisture may condense inside or outside the camera. This moisture condensation may cause a malfunction of the camera.

Moisture condensation occurs easily when:

- The camera is brought from a cold location such as a ski slope into a warmly heated room.
- The camera is taken from an air-conditioned room or car interior to the hot outdoors, etc.

How to prevent moisture condensation

When bringing the camera from a cold place to a warm place, seal the camera in a plastic bag and allow it to adapt to conditions at the new location over a period of time (about an hour).

If moisture condensation occurs

Turn off the camera and wait about an hour for the moisture to evaporate. Note that if you attempt to shoot with moisture remaining inside the lens, you will be unable to record clear images.

On internal rechargeable button battery

This camera has an internal rechargeable button battery for maintaining the date and time and other settings regardless of whether the power is on or off.

This rechargeable button battery is continually charged as long as you are using the camera. However, if you use the camera for only short periods it discharges gradually, and if you do not use the camera at all for about one month it becomes completely discharged. In this case, be sure to charge this rechargeable button battery before using the camera.

However, even if this rechargeable button battery is not charged, you can still use the camera as long as you do not record the date and time.

Charging method

Connect the camera to a wall outlet using the AC Adaptor, or install a charged battery pack, and leave the camera for 24 hours or more with the power off.

On discs

Cleaning the disc

- Do not clean a disc using a cleaner before shooting. Use a commercially available blower to remove dust.
- If fingerprints, dust, droplets of water, or oil make the recordable side (the reverse of the printed side) of a disc dirty, the camera may not properly record images on the disc. Be sure to handle discs with care.
- Do not scratch both sides of a disc.
- If a disc does become dirty, wipe it in a straight line from center to edge with a soft dry cloth or a soft cloth lightly moistened with ethyl alcohol or other mild detergent. You can also use a commercially available CD cleaner.

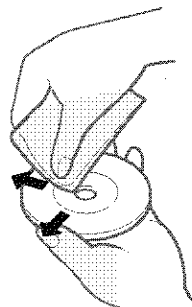

- Do not use any solvent (benzine, thinner, static protection product, record cleaner, etc.) to clean a disc.

Notes

- Do not remove the disc while reading or writing data.
- Data may be damaged if:
 - You remove the disc or shake the camera while reading or writing data.
 - You turn off your camera while reading or writing data.
 - You use the camera in a location subject to the effects of static electricity or noise.
- Do not attach any material on the surface of a disc. This causes a nonuniform rotating speed, which may cause the camera to malfunction.
- You can write only on the label surface of a disc. Write using only an oil-based felt-tip marker and do not touch the ink until dry. Do not heat the disc or use a sharp-pointed tool, such as a ballpoint pen.
- Hold the disc at the edges while supporting the center hole lightly. Do not touch the recordable side (the reverse of the printed side) of a disc.

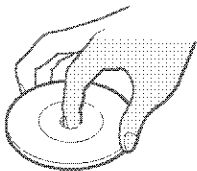

- When you carry or store a disc, put it in its case.
- Do not strike, bend, drop or rub the edge of a disc.

- Do not store a disc in the following locations:
 - In dusty or dirty places
 - Exposed to direct sunlight
 - Near heaters
 - In damp places
- If you attempt to play back a disc on which no images have been recorded using a CD-ROM drive, the CD-ROM drive may malfunction or the disc may be scratched.

On "InfoLITHIUM" battery pack



What is the "InfoLITHIUM" battery pack?

The "InfoLITHIUM" battery pack is a lithium-ion battery pack that has functions for communicating information related to operating conditions between your camera and the AC Adaptor.

The "InfoLITHIUM" battery pack calculates the power consumption according to the operating conditions of your camera, and displays the remaining battery time in minutes.

Charging the battery pack

We recommend charging the battery pack in an ambient temperature of between 10°C to 30°C (50°F to 86°F). You may not be able to efficiently charge the battery pack outside of this temperature range.

Effective use of the battery pack

- Battery performance decreases in low-temperature surroundings. So, the time that the battery pack can be used is shorter in cold places. We recommend the following to ensure longer battery pack use:
 - Put the battery pack in a pocket close to your body to warm it up, and insert it in your camera immediately before you start shooting.
- Frequently operating the zoom or flash wears out the battery charge faster.
- We recommend having spare battery packs handy for two or three times the expected shooting time, and making trial shots before taking the actual shots.
- Do not expose the battery pack to water. The battery pack is not water-resistant.

Remaining battery time indicator

The power may go off although the battery remaining indicator shows there is enough power to operate. Use the battery pack up and charge the battery pack fully again so that the indication on the battery remaining indicator is correct. Note, however, that the correct battery indication sometimes will not be restored if the camera is used in high temperatures for a long time or left in a fully charged state, or the battery pack is frequently used.

How to store the battery pack

If the battery pack is not to be used for a long time, do the following procedure once per year to maintain proper function.

- 1 Fully charge the battery.
- 2 Discharge on your camera.
- 3 Remove the battery from your camera and store it in a dry, cool place.

Battery life

- The battery life is limited. Battery capacity decreases little by little as you use it more and more, and as time passes. When the battery operating time is shortened considerably, a probable cause is that the battery pack has reached the end of its life. Buy a new battery pack.
- The battery life varies according to how it is stored and the operating conditions and environment for each battery pack.

Specifications

■ Camera

[System]

Image device

6.67 mm (1/2.7 type) color CCD
Primary color filter

Total pixels number of camera

Approx. 3 338 000 pixels

Effective pixels number of camera

Approx. 3 207 000 pixels

Lens

3× zoom lens
f = 6.4 - 19.2 mm (9/32 -
25/32 inches) (41 - 123 mm (1 5/8 -
4 7/8 inches) when converted to a
35 mm still camera
F3.8 - 3.9

Exposure control

Automatic exposure, Scene selection
(7 modes)

White balance

Automatic, Daylight, Cloudy,
Fluorescent, Incandescent, Flash

File format (DCF compliant)

Still images: Exif Ver. 2.2 JPEG
compliant, GIF (for Clip Motion),
TIFF, DPOF compatible
Audio with still image:
MP3G1 compliant (Monaural)
Movies:
MP3G1 compliant (Monaural)

Recording media

8 cm CD-R/CD-RW

Flash

Recommended distance (ISO set to
Auto): 0.8 m to 2.5 m (31 1/2 inches
to 8 feet 2 7/16 inches)

[Drive]

Readout

Non-contact optical readout (using
semiconductor laser)

Laser

Wavelength: 779 to 789 nm
Maximum output: 23 mW

[Input and Output connectors]

A/V OUT (MONO) (Monaural)

Mini-jack

Video: 1 V_{p-p}, 75 Ω, unbalanced,
sync negative

Audio: 327 mV (at a 47 kΩ load)
Output impedance 2.2 kΩ

USB jack mini-B

[LCD screen]

LCD panel

6.2 cm (2.5 type) TFT drive

Total number of dots

123 200 (560×220) dots

[General]

Used battery pack

NP-FM50

Power requirements

7.2 V

Power consumption (during shooting with LCD backlight on)

2.6 W

Operating temperature

0°C to 140°C (32°F to 104°F)

Storage temperature

-20°C to +60°C (4°F to 140°F)

Dimensions

131.7×92.3×73.8 mm
(5 1/4×3 3/4×3 inches)
(W/H/D, excluding maximum
protrusions)

Mass

Approx. 522 g (1 lb 2 oz) (including
battery pack NP-FM50, disc, and lens
cap)

Built-in microphone

Electret condenser microphone

Built-in speaker

Dynamic speaker

Exif print Compatible

Print Image Matching II Compatible

■ AC-L15A/L15B AC Adaptor

Power requirements

100 - 240 V AC, 50/60 Hz

Current consumption

0.35 - 0.18 A

Power consumption

18 W

Output voltage

8.4 V DC, 1.5 A

Operating temperature

0°C to 140°C (32°F to 1104°F)

Storage temperature

20°C to +60°C (-4°F to +140°F)

Dimensions (approx.)

56×31×100 mm
(2 1/4×1 1/4×4 inches) (w/h/c)
excluding projecting parts

Mass (approx.)

190 g (6.7 oz) excluding power cord

■ NP-FM50 battery pack

Used battery

Lithium-ion battery

Maximum voltage

DC 8.4 V

Nominal voltage

DC 7.2 V

Capacity 8.5 Wh (1180 mAh)

■ Accessories

- AC Adaptor (1)
- Power cord (1)
- USB cable (1)
- NP-FM50 battery pack (1)
- A/V connecting cable (1)
- 8 cm CD adaptor (1)
- Minicase disc (2) (CD-R (1), CD-RW (1))
- Shoulder strap (1)
- Lens cap (1)
- Lens cap strap (1)
- CD-ROM (SPVD-010) (1)
- Operating instructions (1)

Design and specifications are subject to change without notice.

The LCD screen

When shooting still images

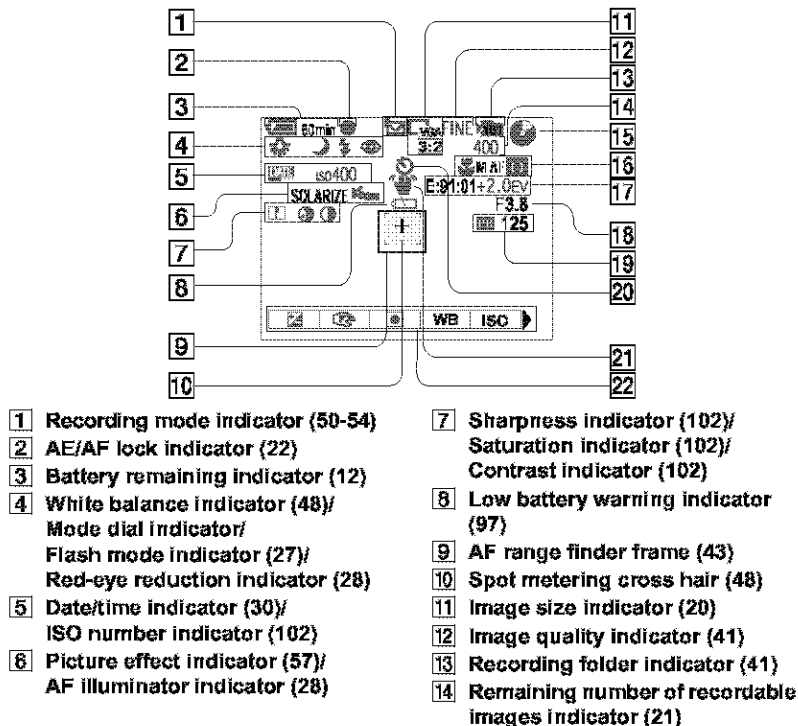



- 15 Remaining disc capacity indicator
- 16 Macro indicator (25)/
AF mode (44)/Multipoint AF []/
Center AF [] indicator (43)/
Focus preset value (46)
- 17 Self-diagnosis display (98)/
EV level indicator (46)
- 18 Aperture value indicator
- 19 NR slow shutter indicator (56)/
Shutter speed indicator
- 20 Self-timer indicator (26)
- 21 Vibration warning indicator (97)
- 22 Menu/Guide menu (40)

• Pressing MENU switches the menu on/off.

Page numbers in parentheses indicate the location of additional important information.

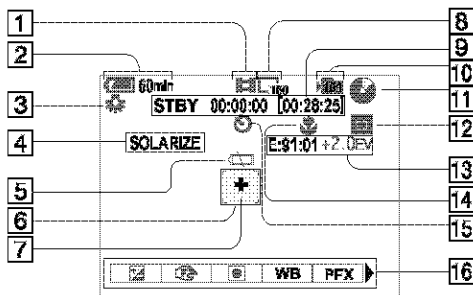
When shooting movies



- | | |
|--|--|
| 1 Recording mode indicator (70) | 10 Recording folder indicator (41) |
| 2 Battery remaining indicator (12) | 11 Remaining disc capacity indicator |
| 3 White balance indicator (48) | 12 Multipoint AF  /Center AF  indicator (43)/Focus preset value (46) |
| 4 Picture effect indicator (57) | 13 Self-diagnosis display (98)/EV level indicator (46) |
| 5 Low battery warning indicator (97) | 14 Macro indicator (25) |
| 6 AF range finder frame (43) | 15 Self-timer indicator (26) |
| 7 Spot metering cross hair (48) | 16 Menu/Guide menu (40) |
| 8 Image size indicator (70) | |
| 9 Recording time [maximum recordable time] indicator (100) | |

• Pressing MENU switches the menu on/off.

When playing back still images

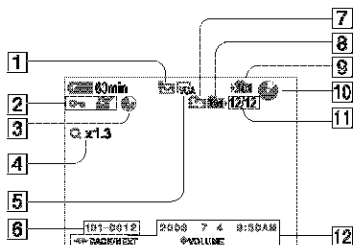

- 1 Recording mode indicator (50-54)
- 2 Protect indicator (65)/
Print (DPOF) mark indicator (67)/
Volume indicator (54)
- 3 Remaining space recovery
indicator (35)
- 4 Zoom scaling indicator (60)/
Jog playback indicator (63)
- 5 Image size indicator (20)
- 6 Folder-file number
- 7 Change folder indicator (59)
- 8 Playback folder indicator (59)
- 9 Recording folder indicator
- 10 Remaining disc capacity
indicator
- 11 Image number/Number of
images recorded in selected
folder
- 12 Recording date and time of the
playback image (30)/Menu/Guide
menu (40)

When playing back movies

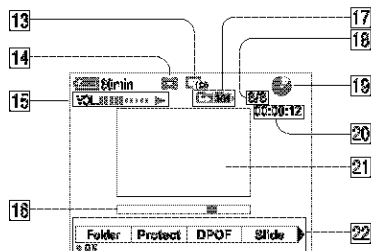

- 13 Image size indicator (71)
- 14 Recording mode indicator (71)
- 15 Volume indicator (71)/Playback
indicator (71)/Remaining space
recovery indicator (35)
- 16 Playback bar (71)
- 17 Change folder indicator (59)/
Playback folder indicator (59)
- 18 Image number/Number of
images recorded in selected
folder
- 19 Remaining disc capacity
indicator
- 20 Counter (71)
- 21 Playback image (71)
- 22 Menu/Guide menu (40)

Page numbers in parentheses indicate the location of additional important information.

Index

A

AC Adaptor	11, 14
Access lamp	18
AI/AF lock	45
AI/AF lock indicator	22
AI illuminator	28, 105
AI lock	45
AI Mode	44
AI range finder frame	43
Auto adjustment mode	22
Auto focus	23, 43
Auto power-off function	15
A/V connecting cable	33

B

Battery pack	
battery life	13, 110
charging	11, 109
charging time	12
remaining indicator	12, 110
Beep/shutter sound	106
Brightness	
image	46
LCD screen	106
Burst	52

C

Charging the recording folder	42
Charging	
battery pack	11, 109
charging time	12
Cleaning	107, 108
Clip Motion	50
Clock set	16
Computer	
copying images	85
ImageMixer	83
PIP Manager	81
USB cable	84
Confirm before write	57
Contrast	102
Control button	10, 15, 40
Copying images	85
Creating a new folder	42

D

DC plug	13, 14
Deleting images	35, 72
Disc	
cleaning	108
finalizing	75
formatting	38
initializing	19
inserting	18
number of images that can be saved or shooting time	99
unfinalizing	76
DPOF	67

E

Editing still images	
Print (DPOF) mark	67
Protect	65
Resize	67
E-mail	53
Enlarging an image	60
EV adjustment	46
External power source	14

F

File	
file names	80
image file storage destinations	79
Flash	
Flash Level	49
Red-eye reduction	28
selecting a flash mode	27
Focusing	
AI lock	45
auto focus method	43
Center AI	43
Continuous AI	44
focus preset	46
Monitoring AI	44
Multi-point AI	43
shooting (using auto adjustment mode)	22
Single AI	44
Folder	
charging the recording folder	42
creating a new folder	42
playback folder	59
recording folder	42
formatting a CD-RW	38

G	
GUI	50, 80
I	
Image	
copying images to your computer	85
file names	80
image file storage destinations	79
image quality	21, 41
image size	20, 99
"InfoLITHIUM" battery pack	109
Installation	
ImageMixer	83
PIP Manager	81
ISO	102
J	
Jog playback	63
JPG	80
L	
LCD screen	
brightness	106
screen display	113, 114, 115
M	
Menu settings	40, 101
Metering mode	
multi-pattern metering	47
spot metering	47
Mode dial	16, 23
Moisture condensation	108

Movie	
deleting movies	72
number of images that can be saved or shooting time	13, 100
shooting movies	70
viewing images on your computer	74
viewing movies on the LCD screen	71
MPEG Movie	70
MPG	80
Multi Burst	51
N	
NR slow shutter	56
NTSC system	34, 106
P	
PAL system	34, 106
Picture effect	57
Power	
AC Adaptor	14
battery pack	11
on/off	15
Precautions	107
Print (DPOF) mark	67
Protect	65
Q	
Quick Review	24
R	
Red-eye reduction	28
RESET button	88
Resize	67

Rotate	62
S	
Saturation	102
Scene Selection	
Beach mode	56
High-speed shutter mode	56
Landscape mode	55
Snow mode	55
Soft snap mode	55
Twilight mode	55
Twilight portrait mode	55
Self-diagnosis display	98
Self-timer	26
Setting	
date and time	16
image size	20
menu items	40, 101
SET UP items	40, 100
Sharpness	102
Shooting mode	
auto adjustment mode	22
Burst	52
Clip Motion	50
E-mail	53
movie	70
Multi Burst	51
TIFF	53
Voice	54
Slide show	61
Smart zoom	25
Still image shooting	
auto adjustment mode	22
EV adjustment	46

image size	20
metering mode	47
number of images that can be saved or shooting time	21, 99
picture effect	57
Scene Selection	55
shooting close-ups (Macro)	25
superimposing the date and time	30
using the flash	27
using the self-timer	26
using the zoom feature	24
White Balance	48
Still image viewing	
delete	35
index screen	32
playback zoom	60
rotate	62
single image screen	31
slide show	61
viewing images on a TV screen	33
viewing images on the LCD screen	31
viewing images on your computer	74
Superimposing the date and time	30

T

TIFF	53
Trimming	61
TV color system	34

U

Unfinalizing a disc	76
USB	81, 84, 87
Using your camera abroad	14

V

Video CD	87
Viewing images on the LCD screen	31, 71
Viewing images on your computer	74
Voice	54

W

Warnings and messages	96
White Balance	48

Z

Zoom	
playback zoom	60
smart zoom	25
using the zoom feature	24

308183511



Printed on 100% recycled paper
using VOC (Volatile Organic
Compound)-free vegetable oil
based ink.

<http://www.sony.net/>
Sony Corporation Printed in Japan

Additional information on this product and answers to frequent
asked questions can be found at our Customer Support Website.