

# ***CD Radio Cassette-Corder***

---

Operating Instructions

***CFD-ZW755***

## Warning

To prevent fire or shock hazard, do not expose the player to rain or moisture.

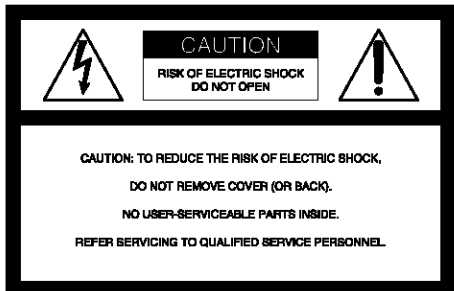

This symbol is intended to alert the user to the presence of uninsulated “dangerous voltage” within the product's enclosure that may be of sufficient magnitude to constitute a risk of electric shock to persons.



This symbol is intended to alert the user to the presence of important operating and maintenance (servicing) instructions in the literature accompanying the appliance.

## CAUTION

The use of optical instruments with this product will increase eye hazard.

## Warning

Do not install the appliance in a confined space, such as a bookcase or built-in cabinet.

## Information

### For customers in the United States

This equipment has been tested and found to comply with the limits for a Class B digital device, pursuant to Part 15 of the FCC Rules. These limits are designed to provide reasonable protection against harmful interference in a residential installation. This equipment generates, uses and can radiate radio frequency energy and, if not installed and used in accordance with the instructions, may cause harmful interference to radio or television reception, which can be determined by turning the equipment off and on, the user is encouraged to try to correct the interference by one or more of the following measures:

- Reorient or relocate the receiving antenna.
- Increase the separation between the equipment and receiver.
- Connect the equipment into an outlet on a circuit different from that to which the receiver is connected.
- Consult the dealer or an experienced radio/TV technician for help.

You are cautioned that any changes or modifications not expressly approved in this manual could void your authority to operate this equipment.

### Owner's Record

The model number is located at the rear of the CD radio cassette-corder and the serial number is located in the battery compartment.

Record the serial number in the space provided below. Refer to these numbers whenever you call upon your Sony dealer regarding this product.

Model No. CFD-ZW755

Serial No. \_\_\_\_\_

---

# Table of contents

---

## Basic Operations

- 4 Playing a CD
  - 6 Listening to the radio
  - 8 Playing a tape
  - 10 Recording on a tape
- 

### The CD Player

- 12 Using the display
- 13 Locating a specific track
- 14 Playing tracks repeatedly (Repeat Play)
- 15 Playing tracks in random order (Shuffle Play)
- 16 Creating your own program (Program Play)
- 18 Enjoying sound effects (LOOP/FLASH)

### The Radio

- 19 Presetting radio stations
- 20 Playing preset radio stations

### The Timer

- 21 Setting the clock
- 22 Waking up to music
- 24 Falling asleep to music

### The Audio Emphasis

- 25 Selecting the audio emphasis (Sound Mode/MEGA BASS)

### Setting Up

- 26 Hooking up the system

### Additional Information

- 29 Precautions
- 31 Troubleshooting
- 33 Maintenance
- 34 Specifications
- 35 Index

# Playing a CD

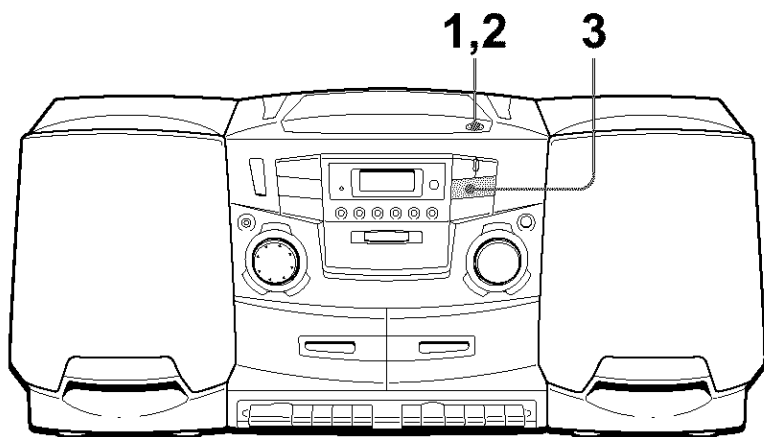

For hookup instructions, see pages 26 – 28.

## 1

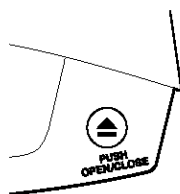

Push ▲ PUSH OPEN/CLOSE down to open the CD compartment and place the CD on the CD compartment.

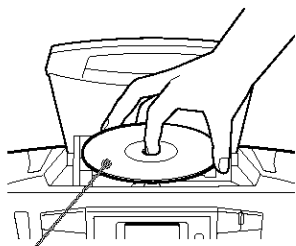

With the label side up

## 2

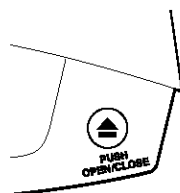

Close the lid of the CD compartment.

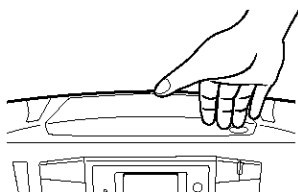

## 3

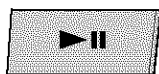

Press ►||.

The player turns on (direct power-on) and plays all the tracks once.

Display

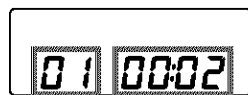

Track number    Playing time

## Use these buttons for additional operations

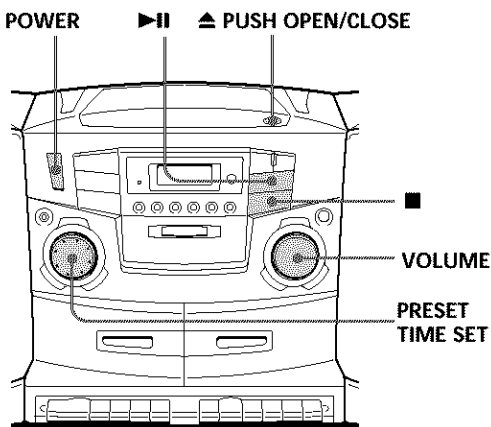
**Tip**

Next time you want to listen to a CD, just press ►||. The player turns on automatically and starts playing the CD.

To	Do this
adjust the volume	Turn VOLUME (Press VOL +, - on the remote).
stop playback	Press ■.
pause playback	Press ►   (   on the remote). Press the button again to resume play after pause.
go to the next track	Turn PRESET • TIME SET clockwise (Press ►► on the remote).
go back to the previous track	Turn PRESET • TIME SET counterclockwise (Press ◀◀ on the remote).
remove the CD	Press ▲ PUSH OPEN/ CLOSE.
turn on/off the player	Press POWER.

# Listening to the radio

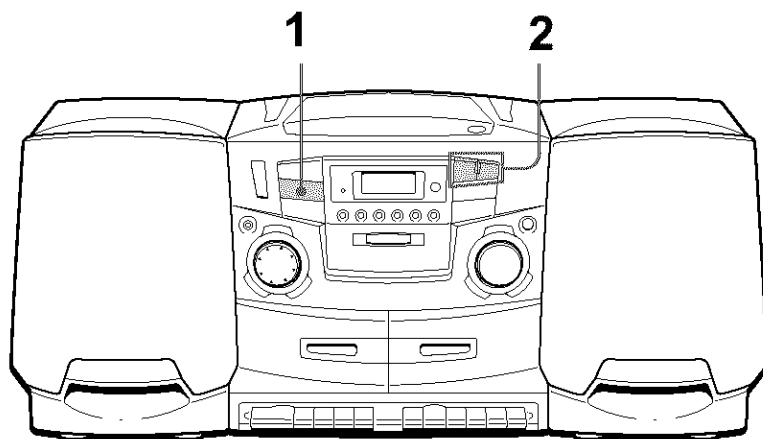

For hookup instructions, see pages 26 – 28.

1



Press RADIO BAND until the band you want appears in the display (direct power-on). Each time you press the button, the indication changes as follows: "FM1" → "FM2" → "AM".

Display

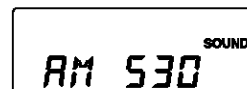

2

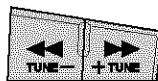

Hold down TUNE + or - until the frequency digits begin to change in the display.

The player automatically scans the radio frequencies and stops when it finds a clear station.

If you cannot tune in to a station, press the button repeatedly to change the frequency step by step.

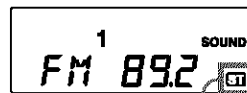

Indicates an FM stereo broadcast

## Use these buttons for additional operations

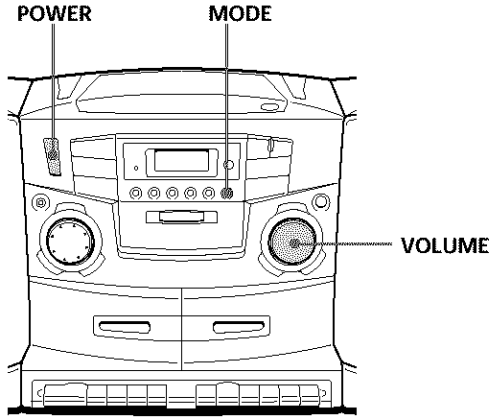
**Tips**

- The "FM1" and "FM2" bands have the same functions. You can store the stations you want separately in "FM1" and "FM2".
- If the FM broadcast is noisy, press MODE until "Mono" appears in the display and radio will play in monaural.
- Next time you want to listen to the radio, just press RADIO BAND. The player turns on automatically and starts playing the previous station.

To	Do this
adjust the volume	Turn VOLUME (Press VOL +, - on the remote).
turn on/off the radio	Press POWER.

**To improve broadcast reception**

Reorient the antenna for FM. Reorient the player itself for AM.

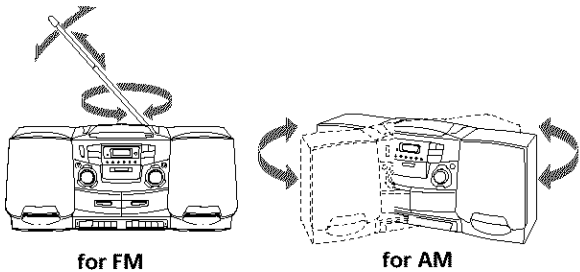

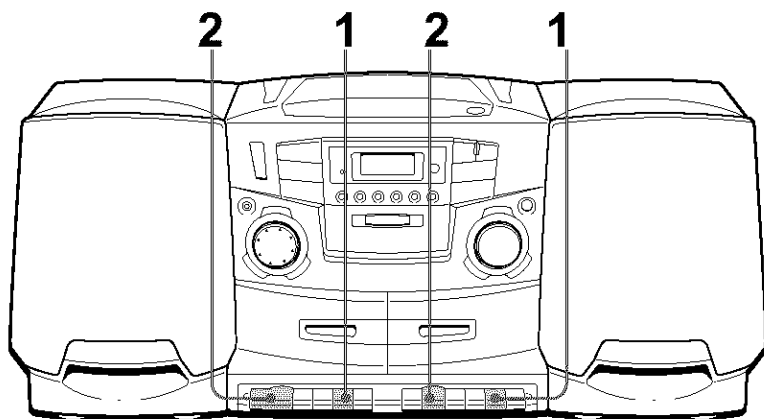

# Playing a tape

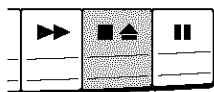

For hookup instructions, see pages 26 – 28.

1



Press  to open the tape compartment and insert a recorded tape. Use TYPE I (normal) tape only. Close the compartment.

With the side you want to play facing you

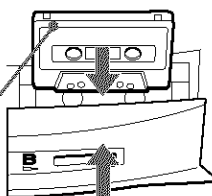

2

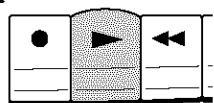

Press .

The player turns on (direct power-on) and starts playing.

Display



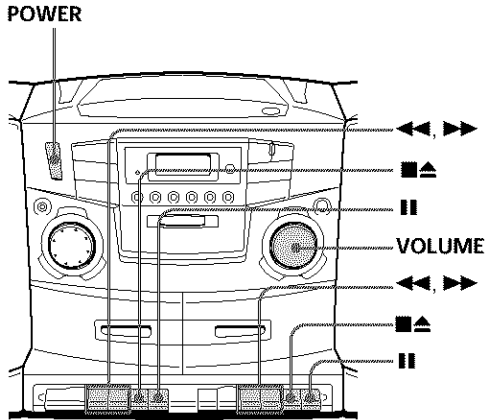

## Use these buttons for additional operations

**Note**

During playback, do not press buttons on the other deck. Otherwise the playback speed may change.

**Tip**

Next time you want to listen to a tape, just press ►. The player turns on automatically and starts playing the tape.

To	Do this
adjust the volume	Turn VOLUME (Press VOL +, - on the remote).
stop playback	Press ■▲.
fast-forward or rewind the tape	Press ►► or ◀◀.
pause playback	Press   . Press the button again to resume play after pause.
eject the cassette	Press ■▲.
turn on/off the player	Press POWER.

# Recording on a tape

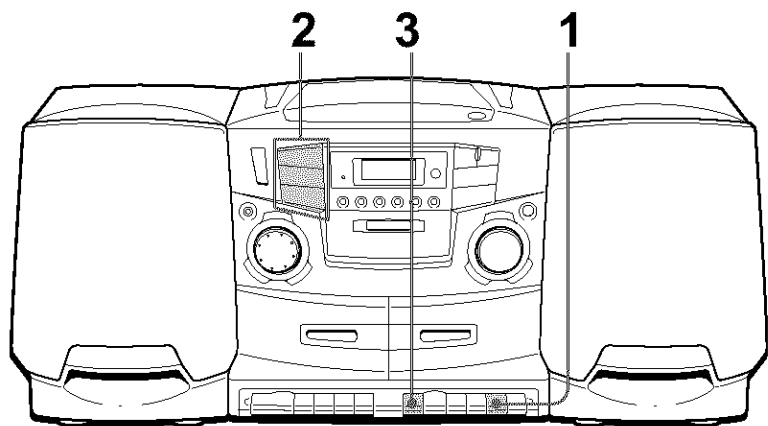

For hookup instructions, see pages 26 – 28.

1

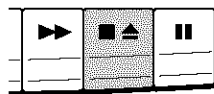

Press **■▲** to open the tape compartment on deck B and insert a blank tape. Use TYPE I (normal) tape only.

With the side you want to record on facing you

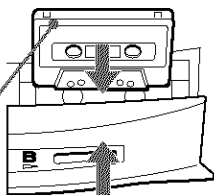

2

Select the program source you want to record.

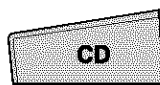

To record from the CD player: insert a CD (see page 4) and press CD.

Display

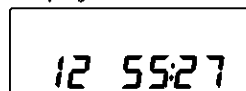

To record from the radio: tune in the station you want (see page 6).

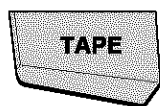
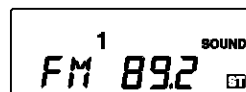

To record from the tape (dubbing): insert a recorded tape into deck A and press TAPE until “dUb” appears in the display.



**3 Deck B**

Start recording.

To record from the CD player and the radio, press ● on deck B (▶ is depressed automatically).

Deck A

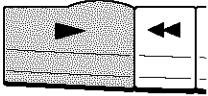

To record from the tape, press ● on deck B (▶ is depressed automatically). Then press ▶ on deck A.

**Tips**

- Adjusting the volume or the audio emphasis (see page 25) will not affect the recording level.
- For the best results, use the AC power as a power source.
- If the AM program makes a whistling sound after you've pressed ● in step 3, press MODE repeatedly until the noise at a minimum.

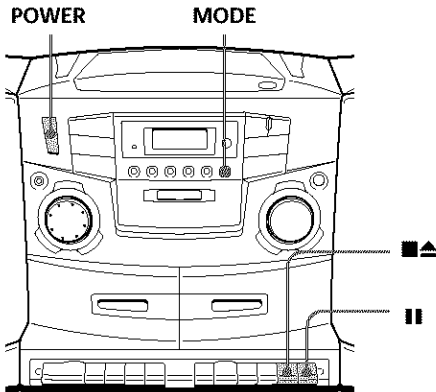
**Use these buttons for additional operations**

To	Press
stop recording	■▲ on deck B
pause recording	on deck B Press the button again to resume recording.
turn on/off the player	POWER

To erase a recording, proceed as follows:

- 1 Insert a tape whose recording you want to erase into deck B.
- 2 Press TAPE until "TAPE" appears in the display.
- 3 Press ● on deck B.

# Using the display

You can check information about the CD using the display.

DSPL ENT MEM

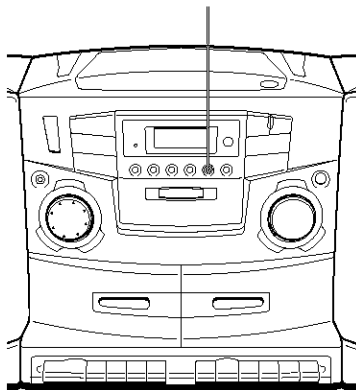

## Checking the total track numbers and playing time

Press DSPL ENT MEM in stop mode.

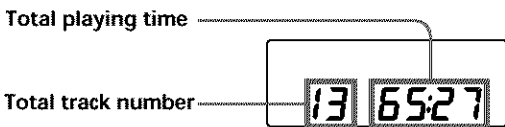

## Checking the remaining time

Press DSPL ENT MEM while playing a CD.

To display	Press DSPL ENT MEM
the current track number and the remaining time on the current track*	once
the number of tracks left and the remaining time on the CD	twice
the current track number and playing time	three times

\* For a track whose number is more than 20 the remaining time appears as "- : -".

# Locating a specific track

You can quickly locate any track using the number buttons on the remote. You can also find a specific point in a track while playing a CD.

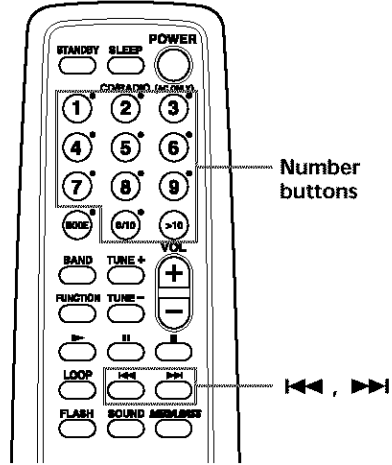

**Note**

You cannot locate a specific track if "SHUF" or "PGM" is lit in the display. Turn off the indication by pressing ■.

**Tip**

When you locate a track numbered over 10, press >10 first, then the corresponding number buttons.  
 Example:  
 To play track number 23, press >10 first, then 2 and 3.

To locate	Press
a specific track directly	number button of the track.
a point while listening to the sound	▶▶▶ (forward) or ◀◀◀ (backward) while playing and hold down until you find the point. (on the player, use ▶▶ or ◀◀.)
a point while observing the display	▶▶▶ (forward) or ◀◀◀ (backward) in pause and hold down until you find the point. (on the player, use ▶▶ or ◀◀.)

# Playing tracks repeatedly

## (Repeat Play)

You can play tracks repeatedly in normal, shuffle or program play modes (see pages 15 and 16).

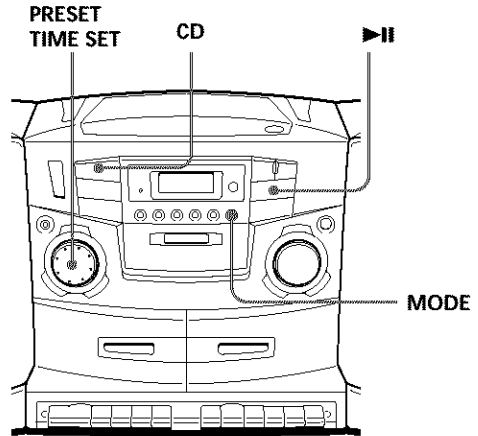

### On the remote

- 1 Press ■.
- 2 Press MODE until the repeat mode you want appears in the display.
- 3 Do either of the following to start repeat play:
  - When you've selected "REP1", select the track by pressing the number buttons.
  - When you've selected "REP ALL", or "SHUF REP", press ►.
  - When you've selected "PGM REP", program tracks (see step 3 on page 16), then press ►.

- 1 Press CD.  
"Cd" appears in the display.
- 2 Proceed as follows.

To repeat	Do this
a single track	1 Press MODE until "REP 1" appears. 2 Turn PRESET • TIME SET to select the track that you want to repeat. 3 Press ►.
all the tracks	1 Press MODE until "REP ALL" appears. 2 Press ►.
tracks in random order	1 Press MODE until "SHUF REP" appears. 2 Press ►.
programmed tracks	1 Press MODE until "PGM REP" appears. 2 Program tracks (see step 3 on page 16). 3 Press ►.

### To cancel Repeat Play

Press MODE until "REP" disappears from the display.

# Playing tracks in random order

## (Shuffle Play)

You can play tracks in random order.

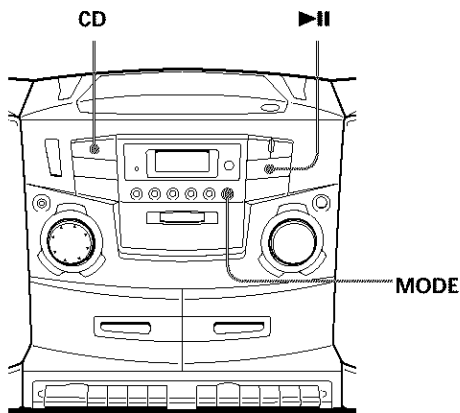

### On the remote

- 1 Press ■.
- 2 Press MODE until "SHUF" appears in the display.
- 3 Press ▶.

- 1 Press CD.

"Cd" appears in the display.

- 2 Press MODE until "SHUF" appears in the display.
- 3 Press ▶|| to start shuffle play.

### To cancel Shuffle Play

Press MODE until "SHUF" disappears from the display.

# Creating your own program

## (Program Play)

You can make a program of up to 20 tracks in the order you want them to be played.

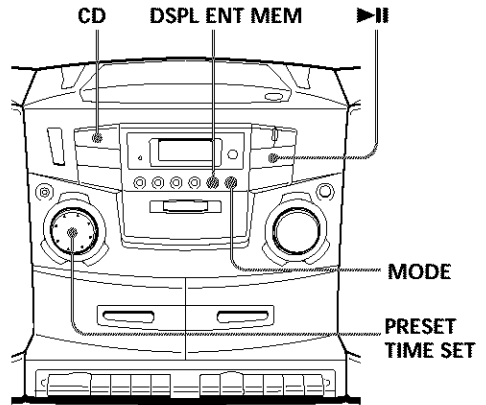

### On the remote

- 1 Press ■.
- 2 Press MODE until "PGM" appears in the display.
- 3 Press the number buttons for the tracks you want to program in the order you want.
- 4 Press ►.

- 1 Press CD.  
"Cd" appears in the display.
- 2 Press MODE until "PGM" appears in the display.
- 3 Turn PRESET • TIME SET then press DSPL ENT MEM for the tracks you want to program in the order you want.

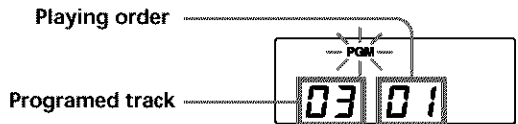

- 4 Press ► to start program play.



**Tips**

- You can play the same program again, since the program is saved until you open the disc compartment.
- You can record your own program. After you've created the program, insert a blank tape into deck B and press ● on deck B to start recording.

**To cancel Program Play**

Press MODE until "PGM" disappears from the display.

**To check the order of tracks before play**

Press DSPL ENT MEM.

Every time you press the button, the track number appears in the programmed order.

**To change the current program**

Press ■ once if the CD is stopped and twice if the CD is playing. The current program will be erased. Then create a new program following the programming procedure.

# Enjoying sound effects (LOOP/FLASH)

You can repeat part of a CD (LOOP) and can “flash” the CD sound (FLASH) during playback.

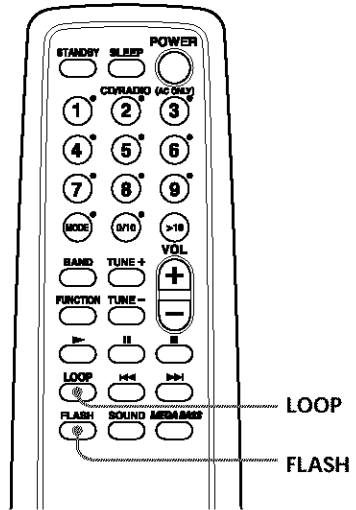

- 1** Play a CD.
- 2** Press and hold LOOP or FLASH at the point you want to start the function.

To	Press and hold
repeat a selected part of a CD	LOOP on the remote
“flash” the CD sound	FLASH on the remote

## To cancel the LOOP or FLASH function

Release the button.

The player returns to normal play.

# Presetting radio stations

You can store radio stations into the player's memory. You can preset up to 30 radio stations, 10 for each band in any order.

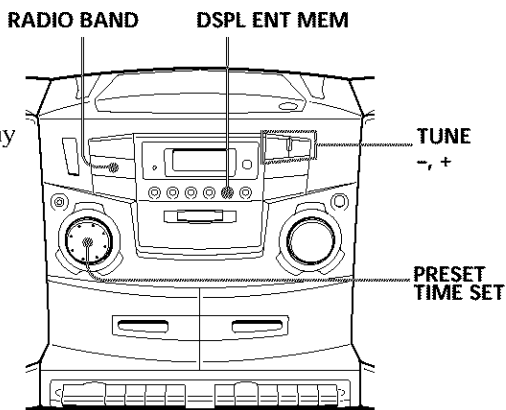

## On the remote

- 1 Press BAND to select the band.
- 2 Set the frequency to the station you want.
- 3 Press and hold the number buttons that you want to preset the new station on for 2 seconds.

- 1 Press RADIO BAND until the band you want appears in the display.
- 2 Set the frequency to the station you want.
- 3 Press and hold DSPL ENT MEM for 2 seconds.
- 4 Turn PRESET • TIME SET until the preset number (1 to 10) you want for the station flashes in the music calender.
- 5 Press DSPL ENT MEM again.

The frequency digits flash in the display and the station is stored into the player's memory.

The new station replaces the old one.

# Playing preset radio stations

Once you have preset the stations, use PRESET +/- on the player or the number buttons on the remote to tune in to your favorite stations.

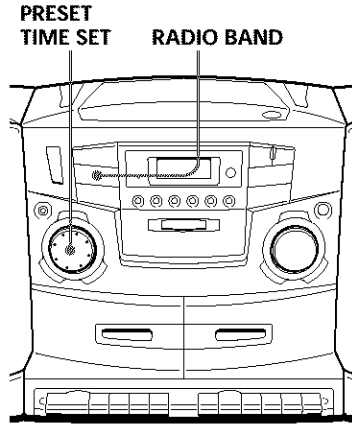

## On the remote

- 1 Press BAND to select the band.
- 2 Press the number buttons to tune in the stored station.

- 1 Press RADIO BAND to select the band.
- 2 Turn PRESET • TIME SET to tune in the stored station.

# Setting the clock

“--:--” indication appears in the display until you set the clock.

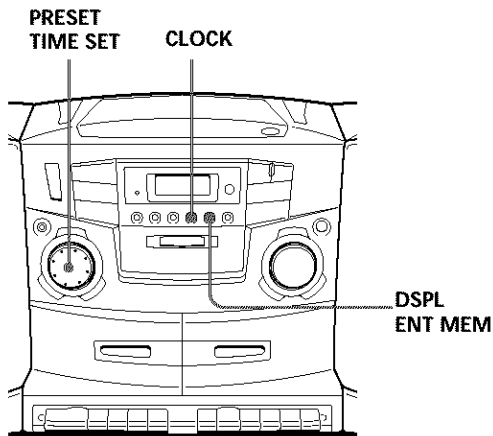

## Tip

The time display system of this player is the 12-hour system:

AM12:00 = midnight

PM12:00 = noon

Before you set the clock, connect the power source (pages 26 - 28).

- 1 Press and hold **CLOCK** for 2 seconds until the hour digits flash.



- 2 Turn **PRESET•TIME SET** until you set the current hour. Then press **DSPL ENT MEM**.

The minute digits flash. Set the minutes by turning **PRESET•TIME SET** until the correct minute is displayed.

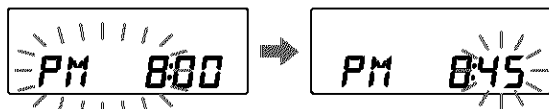

- 3 Press **DSPL ENT MEM**.  
The clock starts from 00 seconds.

# Waking up to music

You can wake up to music or a radio program at a preset time. Make sure you have set the clock ("Setting the clock" on page 21).

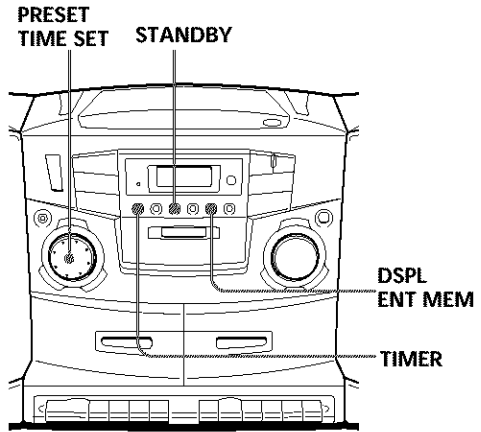

Before you begin, make sure the ⌚ (clock) indication is not lit in the display. If it is lit, press STANDBY.

- 1 Prepare the music source you want to play.

To play	Do this
a CD	Insert a CD.
the radio	Tune in a station

- 2 Press TIMER.

The ⌚ (clock) and the music source ("Cd" or "RAdIO") flash.

- 3 Select the music source ("Cd" or "RAdIO") by turning PRESET•TIME SET, then DSPL ENT MEM.

- 4 Set the timer to the hour you want the music to start by turning PRESET•TIME SET, then DSPL ENT MEM.



Set the minutes by turning PRESET•TIME SET, then DSPL ENT MEM.

- 5 Set the timer to the hour and the minutes you want the music to go off. (Do as step 4.)

**Tips**

- To exit the standby mode, press STANDBY to make the ⏻ indication disappear from the display.
- The preset settings remain until you reset them.

- 6** Set the volume by turning PRESET•TIME SET, then DSPL ENT MEM.



- 7** Press STANDBY.

The ⏻ indication lights up and the power goes off.

At the preset time, the power will go on, and the music will play. Then the power will go off at the preset time, and the player will enter into the standby mode.

**To use the player before a timer playback starts**

Just turn on the player, and then you can use it.

If you turn off the player before the preset time, timer playback will start at the preset time.

In case of the radio, however, if you listen to the station which is different from the one you tuned in in step 1 on page 22, you will hear that station at the preset time. Make sure to tune in the station you want to listen to before you turn off the player.

**To stop play**

Press POWER to turn off the power.

# Falling asleep to music

You can set the player to turn off automatically after 10, 20, 30, 60, 90, and 120 minutes, allowing you to fall asleep while listening to music.

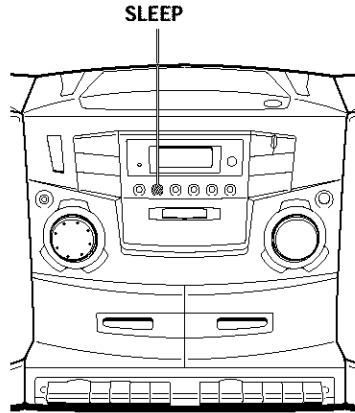

## Tips

- When you are playing radio or CD, make sure that  of the tape player is not depressed.
- You can fall asleep and wake up to different music. Set the waking up timer first (see page 22), turn on the power, and then set the sleeping timer. However, you cannot store different radio stations.

## Note

When you are playing a tape using this function: If the tape length of one side is longer than the set time, the player will not go off until the tape reaches the end.

- 1 Play the music source you want.
- 2 Press SLEEP to display "SLEEP".
- 3 Press SLEEP to select the minutes until the player goes off automatically.

Each time you press the button, the indication changes as follows:



"60" → "90" → "120" → no indication → "10" → "20" → "30."

## To cancel the sleep function

Press POWER to turn off the power.



# Selecting the audio emphasis

(Sound Mode/MEGA BASS)

You can adjust the audio emphasis of the sound you are listening to.

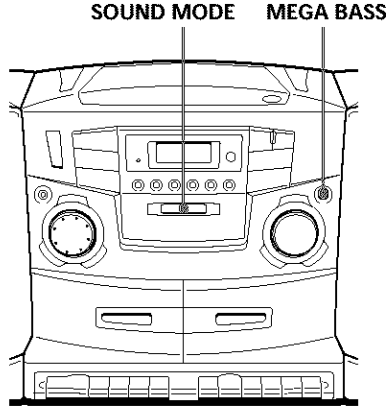

The Audio Emphasis

**On the remote**  
Use SOUND instead of SOUND MODE.

## Selecting the sound characteristic

Press SOUND MODE button to select the sound characteristic you want.

Choose	To get
<b>ROCK</b>	<b>Rock'n'roll:</b> powerful, clean sounds
<b>POP</b>	<b>Popular music:</b> light, bright sounds
<b>JAZZ</b>	<b>Jazz:</b> clear bass audio and powerful sounds of instruments such as piano or guitar
<b>VOCAL</b>	<b>Vocal:</b> the presence of vocals, stressing middle range audio
<b>OFF</b>	the whole dynamic range for music such as classical music

## Reinforcing the bass sound

Press MEGA BASS.  
"MEGA BASS" appears in the display.  
To return to normal sound, press the button again.

# Hooking up the system

Make sure you turn off the power before making any connections.

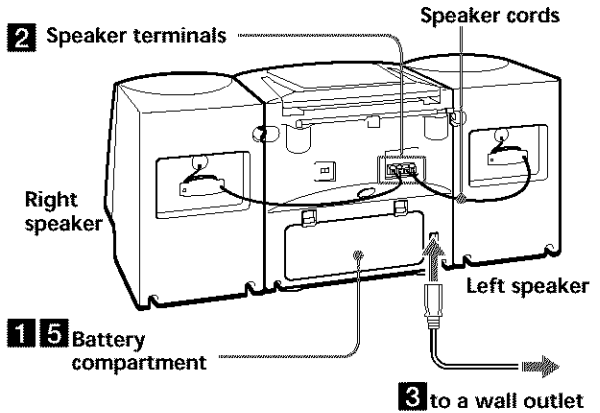

## 1 Inserting the back-up batteries

Insert three size AA (R6) batteries (not supplied) into the battery compartment. These batteries work to save the memory data.

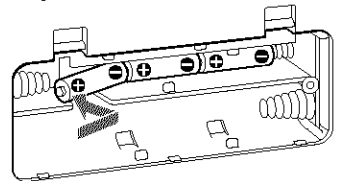

To remove the batteries, push the **+** side.

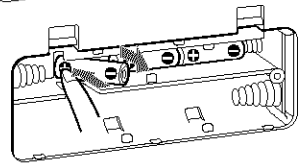

## 2 Hooking up the speakers

**1** Align the grooves and slide the speaker box down until it snaps into place A.

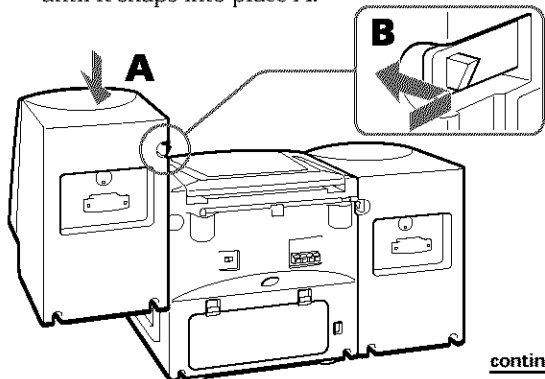

### Tips

- To detach the speakers, unlock speaker (see B on the diagram) and slide the speaker box all the way up and away from the player.
- Connect the speakers for this unit only to the speaker terminals of this unit. If you connect any other speakers or equipment, malfunction may occur.

continued

- 2** Connect the black wires to (-) minus and the red wires to (+) plus terminals; the right speaker wires to the R and the left speaker wires to the L terminals.

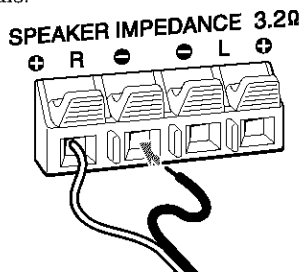

### **3** Connecting the AC power cord

Insert one end of the supplied AC power cord to the AC IN socket located at the rear of the player, and the other end to the wall outlet.

### **4** Inserting batteries into the remote

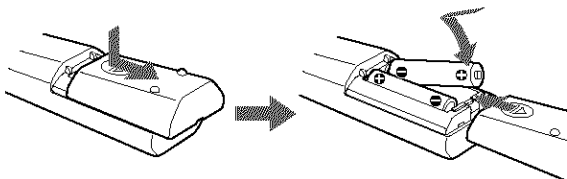

Insert two size AA (R6) batteries (not supplied)

### Replacing batteries

With normal use, the batteries should last for about six months. When the remote no longer operates the player, replace all the batteries with new ones.

**Note**

When you operate the player on batteries, you cannot turn on the player using the remote.

**Tip**

Replace the batteries when the OPR/BATT indicator dims or when the player stops operating. Replace all the batteries with new ones. Before you replace the batteries, be sure to take out the CD from the player.

**5 Using the player on batteries**

Insert six size D (R20) batteries (not supplied) into the battery compartment.

To use the player on batteries, disconnect the AC power cord from the player.

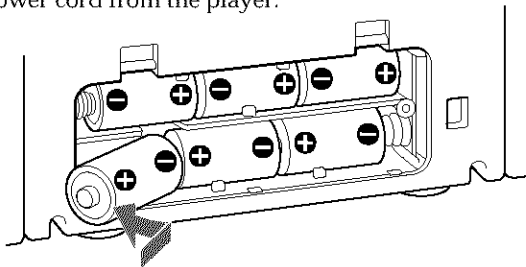

# Precautions

## On safety

- As the laser beam used in the CD player section is harmful to the eyes, do not attempt to disassemble the casing. Refer servicing to qualified personnel only.
- Should any solid object or liquid fall into the player, unplug the player, and have it checked by qualified personnel before operating it any further.

## On power sources

- For AC operation use the supplied AC power cord; do not use any other type.
- The player is not disconnected from the AC power source (mains) as long as it is connected to the wall outlet, even if the player itself has been turned off.
- Unplug the player from the wall outlet when it is not to be used for an extended period of time.
- For battery operation, use six size D (R20) batteries.
- When the batteries are not to be used, remove them to avoid damage that can be caused by battery leakage or corrosion.
- The nameplate indicating operating voltage, power consumption, etc. is located at the rear.

## On placement

- Do not leave the player in a location near heat sources, or in a place subject to direct sunlight, excessive dust or mechanical shock.
- Do not place the player on an inclined or unstable place.
- Do not place anything within 10 mm of the side of the cabinet. The ventilation holes must be unobstructed for the player to operate properly and prolong the life of its components.
- If the player is left in a car parked in the sun, be sure to choose a location in the car where the player will not be subjected to the direct rays of the sun.
- Since a strong magnet is used for the speakers, keep personal credit cards using magnetic coding or spring-wound watches away from the player to prevent possible damage from the magnet.

## On operation

- If the player is brought directly from a cold to a warm location, or is placed in a very damp room, moisture may condense on the lens inside the CD player section. Should this occur, the player will not operate properly. In this case, remove the CD and wait about an hour for the moisture to evaporate.
- If the player has not been used for a long time, set it in the playback mode to warm it up for a few minutes before inserting a cassette.

If you have any questions or problems concerning your player, please consult your nearest Sony dealer.

### Notes on CDs

- Before playing, clean the CD with a cleaning cloth. Wipe the CD from the center out.



- Do not use solvents such as benzine, thinner, commercially available cleaners or anti-static spray intended for vinyl LPs.
- Do not expose the CD to direct sunlight or heat sources such as hot air ducts, nor leave it in a car parked in direct sunlight as there can be a considerable rise in temperature inside the car.
- Do not stick paper or sticker on the CD, nor scratch the surface of the CD.
- After playing, store the CD in its case.

If there is a scratch, dirt or fingerprints on the CD, it may cause tracking error.

### Notes on cassettes

- Break off the cassette tab from side A or B to prevent accidental recording. If you want to reuse the tape for recording, cover the broken tab with adhesive tape.

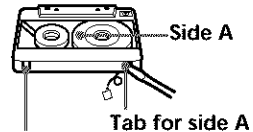

- The use of a cassette with more than 90 minutes of play time is not recommended except for long, continuous recording or playback.

# Troubleshooting

	Symptom	Remedy
General	The power is not on.	<ul style="list-style-type: none"> <li>• Connect the AC power cord to a wall outlet securely.</li> <li>• Make sure the batteries are inserted correctly.</li> <li>• You cannot turn on the player with the remote when you operate the player on batteries.</li> </ul>
	There is no audio.	<ul style="list-style-type: none"> <li>• Make sure the function you want to use appears in the display window.</li> <li>• Adjust the volume.</li> <li>• Unplug the headphones when listening through speakers.</li> </ul>
	Noise is heard.	<ul style="list-style-type: none"> <li>• Someone is using a portable telephone or other equipment that emits radio waves near the player. → Move the portable telephone, etc., away from the player.</li> </ul>
CD Player	"no disc" lights in the display even when a CD is in place.	<ul style="list-style-type: none"> <li>• Insert the CD with the label surface up.</li> </ul>
	The CD does not play.	<ul style="list-style-type: none"> <li>• Make sure that the CD compartment is closed.</li> <li>• Place the CD with the label surface up.</li> <li>• Clean the CD.</li> <li>• Take out the CD and leave the CD compartment open for about an hour to dry moisture condensation.</li> <li>• Make sure "Cd" appears in the display.</li> </ul>
	The sound drops out.	<ul style="list-style-type: none"> <li>• Reduce the volume.</li> <li>• Clean the CD, or replace it if the CD is badly damaged</li> <li>• Place the player in a location free from vibration.</li> <li>• The sound may drop out or noise may be heard if the CD is recorded using a personal computer (CD-R, etc.).</li> </ul>
Radio	The audio is weak or has poor quality.	<ul style="list-style-type: none"> <li>• Replace all the batteries with new ones if they are weak.</li> <li>• Move the player away from the TV.</li> <li>• If you are using the remote while listening to AM radio, noise may be heard. This is unavoidable.</li> </ul>
	The picture of your TV becomes unstable.	<ul style="list-style-type: none"> <li>• If you are listening to an FM program near the TV with an indoor antenna, move the player away from the TV.</li> </ul>

	Symptom	Remedy
Tape Player	The tape does not move when you press an operation button.	<ul style="list-style-type: none"> <li>• Close the cassette compartment securely.</li> </ul>
	The ● button does not function/ The tape does not play.	<ul style="list-style-type: none"> <li>• Make sure the safety tab on the cassette is in place.</li> <li>• Make sure "TAPE" appears in the display.</li> </ul>
	The tape does not erase completely.	<ul style="list-style-type: none"> <li>• Clean the erasing head (see page 33).</li> <li>• Replace all the batteries with new ones if they are weak.</li> <li>• The source which was recorded on TYPE II (high position) or TYPE IV (metal) tape using this unit is being played. Record on TYPE I (normal) tape and play.</li> </ul>
	The tape does not record.	<ul style="list-style-type: none"> <li>• Make sure the tape is inserted properly.</li> <li>• Make sure the safety tab of the cassette is in place.</li> </ul>
	The audio is weak/The audio quality is poor.	<ul style="list-style-type: none"> <li>• Clean the heads, pinch rollers and capstans (See page 33).</li> <li>• Demagnetize the heads using a demagnetizer (see page 33).</li> </ul>
	The sound is distorted.	<ul style="list-style-type: none"> <li>• The TYPE II (high position) or TYPE IV (metal) tape is being used. Use TYPE I (normal) tape only.</li> </ul>
Timer	The timer does not operate.	<ul style="list-style-type: none"> <li>• Make sure the time on the clock is correct.</li> <li>• Check to see if the AC power had been cut off.</li> <li>• Make sure the ⌚ (clock) indication is displayed.</li> </ul>
	The remote does not function.	<ul style="list-style-type: none"> <li>• Replace all the batteries in the remote with new ones if they are weak.</li> <li>• Make sure that you are pointing the remote at the remote sensor on the player.</li> <li>• Remove any obstacles in the path of the remote and the player.</li> <li>• Make sure the remote sensor is not exposed to strong light such as direct sunlight or fluorescent lamp light.</li> <li>• Move closer to the player when using the remote.</li> </ul>
Remote		

After trying the above remedies, if the player still does not function properly, unplug the AC power cord and remove all the batteries. After all the indications in the display disappear, plug the power cord and insert the batteries again. If the problem persists, please consult your nearest Sony dealer.



# Maintenance

## Cleaning the lens

If the lens becomes dirty, it may cause a skipping of sound during CD operation. Clean with a commercially available blower.

## Cleaning the tape heads and tape path

Wipe the heads, the pinch rollers and the capstans with a cleaning swab slightly moistened with cleaning fluid or alcohol after every 10 hours of operation for optimum playback and recording quality. To make the best possible recording, however, we recommend that you clean all surfaces over which tape travels before each recording.

## Demagnetizing the tape heads

After 20 to 30 hours of use, enough residual magnetism will have built up on the tape heads to begin to cause loss of high frequency sound and hiss. At this time, you should demagnetize the heads and all metal parts in the tape path with a commercially available tape head demagnetizer.

## Cleaning the cabinet

Clean the cabinet, panel and controls with a soft cloth slightly moistened with a mild detergent solution. Do not use any type of abrasive pad, scouring powder, or solvent, such as alcohol or benzene.

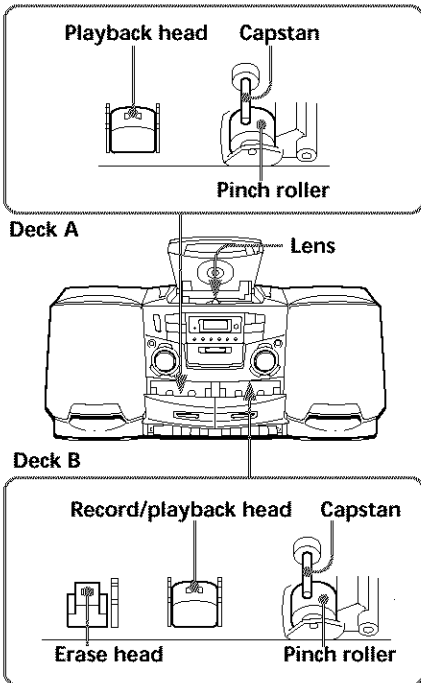

After cleaning, insert a tape when the areas cleaned are completely dry.

# Specifications

## AUDIO POWER SPECIFICATIONS

### POWER OUTPUT AND TOTAL HARMONIC DISTORTION

With 3.2-ohm loads, both channel driven from 150 - 6,300 Hz; rated 1.6 W per channel-minimum RMS power, with no more than 10 % total harmonic distortion in AC operation.

## Other Specifications

### CD player section

#### System

Compact disc digital audio system

#### Laser diode properties

Material: GaAlAs

Wave length: 780 nm

Emission duration: Continuous

Laser output: Less than 44.6  $\mu$ W

(This output is the value measured at a distance of about 200 mm from the objective lens surface on the optical pick-up block with 7 mm aperture.)

#### Spindle speed

200 r/min (rpm) to 500 r/min (rpm) (CLV)

#### Number of channels

2

#### Frequency response

20 - 20,000 Hz +1/-1 dB

#### Wow and flutter

Below measurable limit

### Radio section

#### Frequency range

FM: 87.5 - 108 MHz

AM: 530 - 1,710 kHz

#### Antennas

FM: Telescopic antenna

AM: Built-in ferrite bar antenna

### Cassette-corder section

#### Recording system

4-track 2 channel stereo

#### Fast winding time

Approx. 120 s (sec.) with Sony cassette C-60

#### Frequency response

TYPE I (normal): 80 - 10,000 Hz

### General

#### Speaker

Full range: 10 cm (4 in.) dia.,

3.2 ohms, cone type (2)

#### Outputs

Headphones jack (stereo minijack)

For 16 - 68 ohms impedance headphones

#### Power requirements

For CD radio cassette-corder:

120 V AC, 60 Hz

9 V DC, 6 size D (R20) batteries

For memory back-up:

4.5 V DC, 3 size AA (R6) batteries

For remote control:

3 V DC, 2 size AA (R6) batteries

#### Power consumption

AC 15 W

#### Battery life

For CD radio cassette-corder:

---

#### FM recording

---

Sony R20P: approx. 7.5 h

Sony alkaline LR20: approx. 22 h

---

#### Tape playback

---

Sony R20P: approx. 7 h

Sony alkaline LR20: approx. 20 h

---

#### CD playback

---

Sony R20P: approx. 3 h

Sony alkaline LR20: approx. 10 h

---

For memory back-up: approx. 1 year

#### Dimensions

Approx. 650 × 265 × 256 mm (w/h/d)

(25 1/8 × 10 1/2 × 10 1/8 inches) (incl. projecting parts)

#### Mass

Approx. 6.7 kg (14 lb. 12 oz) (incl. batteries)

#### Supplied accessory

AC power cord (1)

Remote control (1)

Design and specifications are subject to change without notice.

### Optional accessories

Sony MDR headphone series

# Index

## A

Audio emphasis 25

## B

Batteries

for memory 26

for player 28

for remote 27

## C

CD player 12

Cleaning

cabinet 33

lens 33

tape heads and tape path  
33

Connecting

AC power cord 27

Creating your own program  
16

## D, E

Demagnetizing the tape  
heads 33

Display 12

## F, G, H

FLASH 18

## I, J, K

Improving broadcast  
reception 7

## L

Listening to the radio 6

Locating a specific track 13

LOOP 18

## M, N, O

MEGA BASS 25

## P, Q

Playing

a CD 4

a tape 8

preset radio stations 20

tracks in random order  
15

tracks repeatedly 14

Program Play 16

## R

Radio stations

Playing 20

Presetting 19

Recording

on a tape 10

Repeat Play 14

## S

Selecting

audio emphasis 25

tracks 13

Setting the clock 21

Setting up 27

Shuffle play 15

SOUND 25

Sound mode 25

## T

Tape player 8

Timer

Falling asleep to music 24

Waking up to music 22

Troubleshooting 31

## U, V, W, X, Y, Z

Using the display 12

