

Owner's Manual

Stainless Steel
Professional
36" and 48"
Gas Cooktops



Monogram.®
We bring good things to life.

Introduction

Your new Monogram cooktop makes an eloquent statement of style, convenience and kitchen planning flexibility. Whether you chose it for its purity of design, assiduous attention to detail—or for both of these reasons—you’ll find that your Monogram cooktop’s superior blend of form and function will delight you for years to come.

Your Monogram cooktop was designed to provide the flexibility to blend in with your kitchen cabinetry. Its sleek design can be beautifully integrated into the kitchen.

The information on the following pages will help you operate and maintain your cooktop properly.

Contents

Care and Cleaning

Burner Assembly 18
Ceramic Briquettes 16
Control Knobs 16
Drip Trays, Drain Tubes 17
Griddle 17
Grille 16
Stainless Steel 16

Consumer Services

Important Phone Numbers 21
Model and Serial Number 3, 24
Problem Solver 19
Product Registration 3, 23, 24
Safety Instructions 2, 4-7
Warranty 22

Using Your Cooktop

Burners 9-11
Controls 8, 9, 12
Cookware 12
Features 8
Griddle 14, 15
Grille 12-14
Electric Igniters 10
Simmering 10

WARNING: If the information in this manual is not followed exactly, a fire or explosion may result causing property damage, personal injury or death.

- Do not store or use gasoline or other flammable vapors and liquids in the vicinity of this or any other appliance.
— WHAT TO DO IF YOU SMELL GAS
• Do not try to light appliance.
• Do not touch any electrical switch; do not use any phone in your building.
• Immediately call your gas supplier from a neighbor’s phone. Follow the gas supplier’s instructions.
• If you cannot reach your gas supplier, call the fire department.
— Installation and service must be performed by a qualified installer, service agency or the gas supplier.



*Before
using
your
cooktop*

Read this manual carefully. It is intended to help you operate and maintain your new cooktop properly.

Keep it handy for answers to your questions.

If you don't understand something or need more help, there is a list of toll-free consumer service numbers included in the back section of this manual.

OR

Visit our Website at: www.monogram.com

*Write
down the
model &
serial
numbers*

You'll find them on a label in the rear of the burner box below the burner grates.

These numbers are also on the Consumer Product Ownership Registration Card included in this manual.

Before sending in this card, please write these numbers here:

Model Number

Serial Number

Use these numbers in any correspondence or service calls concerning your cooktop.

*If you
received a
damaged
cooktop*

Immediately contact the dealer (or builder) that sold you the cooktop.

*Save time
& money*

Before you request service, check the Problem Solver in the back of this manual.

It lists causes of minor operating problems that you can correct yourself.

*If you
need
service*

To obtain service, see the Consumer Services page in the back of this manual.

We're proud of our service and want you to be pleased. If for some reason you are not happy with the service you receive, here are the steps to follow for further help.

FIRST, contact the people who serviced your appliance. Explain why you are not pleased. In most cases, this will solve the problem.

NEXT, if you are still not pleased, write all the details—including your phone number—to:

Manager, Customer Relations
GE Appliances
Appliance Park
Louisville, KY 40225

IMPORTANT SAFETY INSTRUCTIONS

IMPORTANT SAFETY NOTICE

- **The California Safe Drinking Water and Toxic Enforcement Act** requires the Governor of California to publish a list of substances known to the state to cause birth defects or other reproductive harm, and requires businesses to warn customers of potential exposure to such substances.
- **Gas appliances can cause minor exposure to four of these substances**, namely benzene, carbon monoxide, formaldehyde and soot, caused primarily by the incomplete combustion of natural gas or LP fuels.

Properly adjusted burners, indicated by a bluish rather than a yellow flame, will minimize incomplete combustion. Exposure to these substances can be minimized by venting with an open window or using a ventilation fan or hood.

SAFETY PRECAUTIONS

When using your appliance, follow basic safety precautions, including the following:

- **Have the installer show you the location of the cooktop gas cut-off valve and how to shut it off if necessary.**
- **Be sure all packing materials are removed from the cooktop** before operating it to prevent fire or smoke damage should the packing material ignite.
- **Locate the cooktop out of kitchen traffic path and out of drafty locations and areas with poor air circulation.**
- **Do not attempt to repair or replace any part of your cooktop unless it is specifically recommended in this manual.** All other servicing should be referred to a qualified technician.
- **Be sure your cooktop is correctly adjusted by a qualified service technician or installer for the type of gas (natural or LP) that is to be used.**

WARNING: These adjustments must be made by a qualified service technician in accordance with the manufacturer's instructions and all codes and requirements of the authority having jurisdiction. Failure to follow these instructions could result in serious injury or property damage. The qualified agency performing this work assumes responsibility for the conversion.
- **Use this appliance only for its intended use** as described in this manual.
- **Be sure your appliance is properly installed and grounded** by a qualified technician in accordance with the provided installation instructions.

SAFETY PRECAUTIONS

- **Before performing any service, DISCONNECT THE COOKTOP POWER SUPPLY AT THE HOUSEHOLD DISTRIBUTION PANEL BY REMOVING THE FUSE OR SWITCHING OFF THE CIRCUIT BREAKER.**
- **Do not leave children alone**—children should not be left alone or unattended in an area where an appliance is in use. They should never be allowed to sit or stand on any part of the appliance.
- **Do not allow anyone to climb, stand or hang on the drip tray handles or cooktop.** They could damage the cooktop and even tip it over, causing severe personal injury.
- **Do not store flammable materials near the cooktop.**
- **CAUTION: ITEMS OF INTEREST TO CHILDREN SHOULD NOT BE STORED IN CABINETS ABOVE A COOKTOP—CHILDREN CLIMBING ON THE COOKTOP TO REACH ITEMS COULD BE SERIOUSLY INJURED.**
- **For your safety, never use your appliance for warming or heating the room.**
- **Never wear loose-fitting or hanging garments while using the appliance.** Be careful when reaching for items stored over the cooktop. Flammable material could be ignited if brought in contact with burners or burner grates and may cause severe burns.
- **Use only dry pot holders**—moist or damp pot holders on hot surfaces may result in burns from steam. Do not let pot holders touch burners or burner grates. Do not use a towel or other bulky cloth.
- **When cooking, do not touch the burners, burner grates, grille or griddle (on some models) or the surrounding areas.**

These surfaces may be hot enough to burn.

During and after use, do not touch, or let clothing or other flammable materials contact, the burners, grille or griddle (on some models) or areas near the burners; allow sufficient time for cooling first.

Potentially hot surfaces include the cooktop, areas facing the cooktop and the drip tray handles.

The drip trays can get hot. Do not remove the drip trays until they are cool.
- **Keep the ventilator hood and grease filters clean to maintain good venting and to avoid grease fires.** Turn the ventilator OFF in case of fire or when intentionally “flaming” liquor or other spirits on the cooktop. The blower, if in operation, could spread the flames.
- **DO NOT obstruct the flow of combustion or ventilation air to the appliance.** Be sure a fresh air supply is available.

IMPORTANT SAFETY INSTRUCTIONS

SAFETY PRECAUTIONS

- **Do not use water on grease fires. Never pick up a flaming pan.** Turn the controls off. Smother a flaming pan on a surface unit by covering the pan completely with a well-fitting lid, cookie sheet or flat tray. Use a multi-purpose dry chemical or foam-type fire extinguisher.

Flaming grease outside a pan can be put out by covering it with baking soda or, if available, by using a multi-purpose dry chemical or foam-type fire extinguisher.
- **DO NOT STORE OR USE COMBUSTIBLE MATERIALS, GASOLINE OR OTHER FLAMMABLE VAPORS AND LIQUIDS IN THE VICINITY OF THIS OR ANY OTHER APPLIANCE.**
- **Do not let cooking grease or other flammable materials accumulate in or near the cooktop. Clean drip trays and liners after every use.**
- **If you smell gas,** the installer has not done a proper job of checking for leaks. You can have a small leak and therefore a faint gas smell if the connections are not completely tight.

Finding a gas leak is **NOT** a do-it-yourself procedure. Some leaks can only be found with the burner control in the ON position and for your protection it must be done by a qualified service technician. Never use an open flame to locate a leak.
- **If by some chance a burner goes out and gas escapes, open a window or a door to let the room air out.** Do not attempt to use the appliance until the gas has had time to dissipate. Follow the instructions in What to do if You Smell Gas.
- **Do not use aluminum foil to line any part of the cooktop.** Using a foil liner could result in a fire hazard or the obstruction of the flow of combustion and ventilation air. Foil is an excellent heat insulator and heat will be trapped underneath it. This trapped heat can upset the cooking performance and can damage the finish of the cooktop.
- **Do not heat unopened food containers;** a build-up of pressure may cause the container to burst.
- **Set the burner control so that the flame heats only the bottom of the pan** and does not extend beyond the bottom of the pan. Excessive flame is hazardous. The high BTU burners can easily melt cookware handles.
- **Hold the handle of the pan, using a dry pot holder,** to prevent movement of the utensil when stirring or turning food.
- **Always heat fat slowly, and watch as it heats.**
- **Always use the LITE position when igniting the burners** and make sure the burners have ignited, including the center simmer flame.
- **Never leave the burners unattended at high flame settings.** Boilovers cause smoking and greasy spillovers that may catch on fire. If the burner flames are smothered by a severe boilover which affects the ignitor, unburned gas will escape into the room.
- **Do not let pot holders come near open flames when lifting cookware.** Do not use a towel or other bulky cloth in place of a pot holder.
- **To minimize the possibility of burns,** ignition of flammable materials and spillage, turn cookware handles toward the side or back of the cooktop without extending over adjacent burners.
- **Never block the vents (air openings) of the cooktop.** They provide the air inlet and outlet that are necessary for the cooktop to operate properly with correct combustion. Air openings are located at the drip tray and drip tray handle area.

SAFETY PRECAUTIONS

- **Always turn the burners to OFF before removing cookware.**
- **Carefully watch foods being fried at a high flame setting.**
- **Foods for frying should be as dry as possible.** Frost on frozen foods or moisture on fresh foods can cause hot fat to bubble up and over the sides of the pan.
- **Use the least possible amount of fat for effective shallow or deep fat frying.** Filling the pan too full of fat can cause spillovers when food is added.
- **Use a deep fat thermometer** whenever possible to prevent overheating fat beyond the smoking point.
- **Never try to move a pan of hot fat,** especially a deep fat fryer. Wait until the fat is cool.
- **When using glass cookware,** make sure it is designed for cooktop use.
- **If a combination of oils or fats will be used in frying,** stir together before heating or as fats melt slowly.
- **Do not leave any items on the cooktop.** The hot air from the vent may ignite flammable items and will increase pressure in closed containers, which may cause them to burst.
- **Use proper pan size**—avoid pans that are unstable or easily tipped. Select cookware having flat bottoms large enough to properly contain food and avoid boilovers and spillovers and large enough to cover burner grate. This will both save cleaning time and prevent hazardous accumulations of food, since heavy spattering or spillovers left on the cooktop can ignite. Use pans with handles that can be easily grasped and remain cool.
- **Keep all plastics away from the burners.**
- **Do not leave plastic items on the cooktop**—they may melt if left too close to the vent.
- **To avoid the possibility of a burn,** always be certain that the controls for all burners are at the OFF position and all grates are cool before attempting to remove them.
- **When flaming foods are under the hood, turn the fan off.** The fan, if operating, may spread the flames.
- **Grease is flammable.** Let hot grease cool before attempting to handle it. Avoid letting grease deposits collect in the container under the cooktop burners, the grille or the griddle. Clean these areas after each use or boilover.
- **For proper lighting and performance of the burners, keep the burner ports clean.** It may be necessary to clean these when there is a boilover or when the burner does not light, even though the electronic ignitors click.
- **After cleaning, it is important to make sure the outer cap/burner port is properly aligned with the burner base.** Incorrect alignment will produce poor burner performance. Never operate the burner without all burner parts in place.
- **Clean the cooktop with caution.** Avoid steam burns; do not use a wet sponge or cloth to clean the cooktop while it is hot. Some cleaners produce noxious fumes if applied to a hot surface. Follow manufacturer's directions.
- **Do not use the grille for cooking excessively fatty meats or products which promote flare-up.**
- **DO NOT use cookware on the grille.**
- **If cooktop is located near a window,** do not hang long curtains that could blow over the burners and create a fire hazard.
- **Be sure all the controls are turned off and the appliance is cool** before using any type of aerosol cleaner or cooking spray on or around the appliance. The chemical that produces the spraying action could, in the presence of heat, ignite or cause metal parts to corrode.

SAVE THESE INSTRUCTIONS

Features of Your Cooktop

Stainless Steel Cooktop

Design information

(Not all features are on all models. Appearance may vary.)

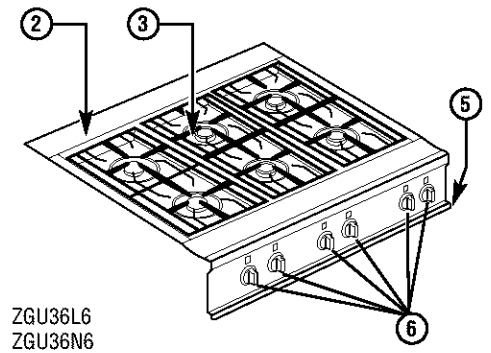
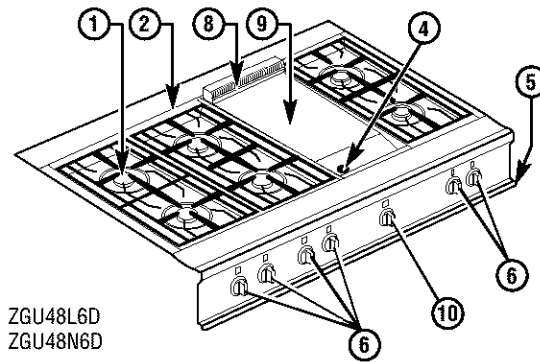
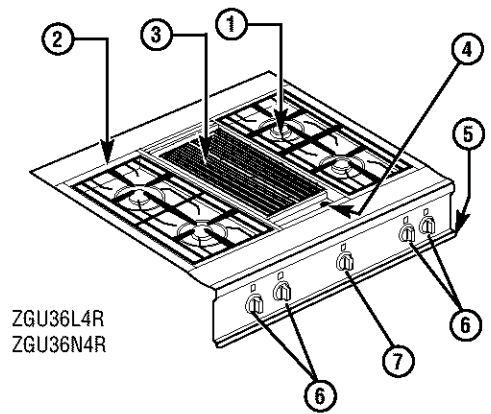
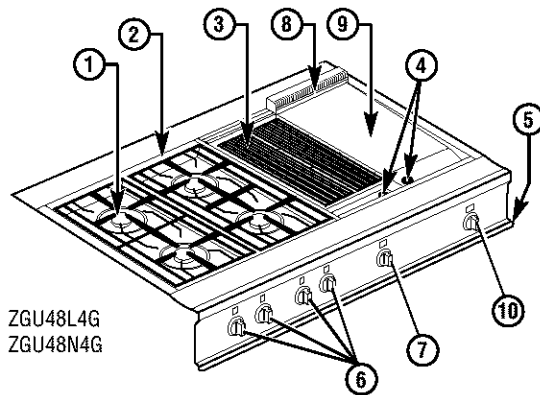
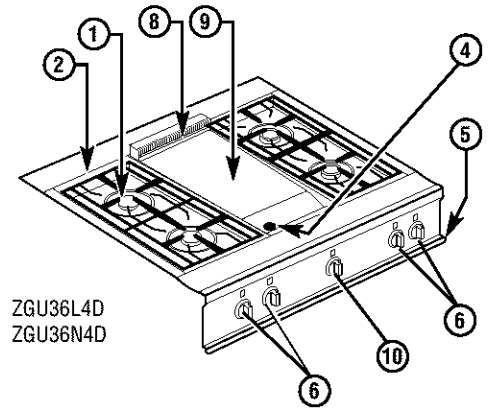
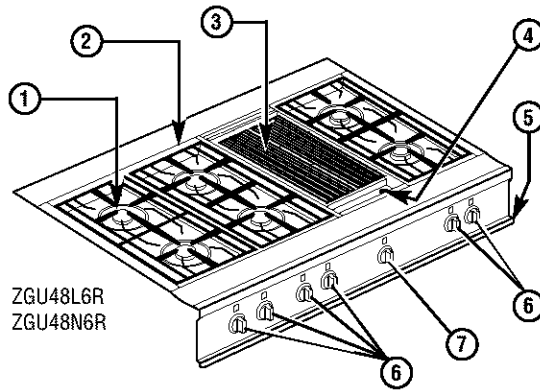

Feature Index	Page
1 Burner Assemblies	9, 18
2 Model and Serial Numbers (in rear of burner box below grates—can be seen when grates and aeration pans are removed)	3, 24
3 Grille	12–14, 16
4 Drain Tubes	17
5 Drip Trays	12, 17
6 Burner Control Knobs	9, 16
7 Grille Control Knob	12, 16
8 Griddle Flue Cover (Vent)	14
9 Griddle	14, 15, 17
10 Griddle Control Knob	15, 16

Control knobs

The control knobs are in front of the burner, grille or griddle (on some models) they control.

The burners have an infinite number of heat settings as there are no fixed positions between HI and LO.

To turn ON a burner, push the control in, then turn it counterclockwise to the LITE position.

Check to be sure the burner you turned on is the one you want to use.

You will hear the ignitor click. When the gas is ignited all around the burner and into the central simmer burner below the simmer cap, turn the knob back to the desired setting.

When using the simmer burner always ensure that it lights from the main burner.

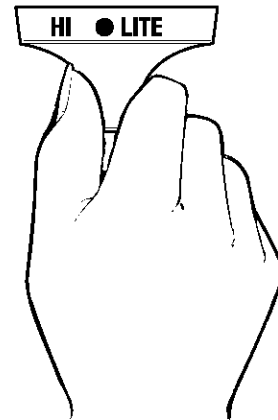

Push the control in and turn it counterclockwise to the LITE position.

Burners

Your new professional gas cooktop is equipped with burners typical of those used in restaurants. These burners are designed in two pieces for easy cleaning and control.

The center, smaller cap covers and protects the simmer burner from boilovers that could put the flame out. This cap also spreads the simmer burner heat out to avoid too much heat being concentrated on the center of the pan.

The simmer burner is always on when the burner is in use. The burner should never be operated if the simmer cap is not in place.

The outer cap/port ring constitutes the main burner and is in operation between the HI and LO settings.

The burners have electronic spark ignition to eliminate continuously burning pilots. When the outer cap/port ring is on and the flame is blown out, it will relight. The burners are rated at 15,000 BTU around the outer cap/port ring. When turned to the simmer setting, only the center of the burner is lit, and it is rated at 500 BTU.

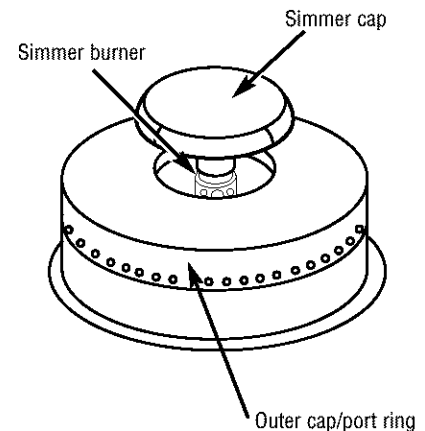

Electronic ignitors

NOTE: Keep the ignitor, ignitor cap and burner ports clean.

If a burner does not ignite, listen for the clicking sound. If the ignitor is not clicking, turn off the burner. Check the circuit breaker for a blown fuse or a tripped circuit breaker. If the ignitor still fails to operate, check the Problem Solver in the back of this manual or the Power Failure information in this section.

NOTE: If you are using propane gas, a slight pop or flash may occur at the burner ports a few seconds after the burner has been turned off. This “extinction pop” is normal for propane gas.

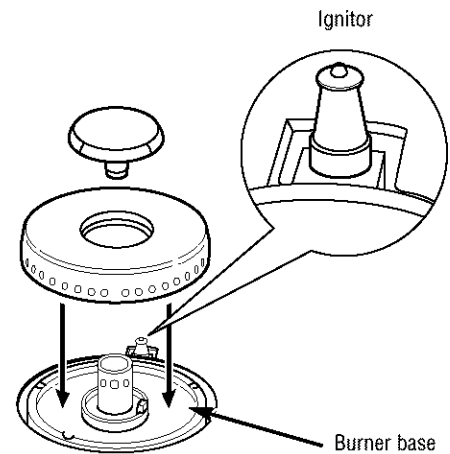

Simmering

Your new professional gas cooktop has exceptionally low simmering capabilities. The center simmer cap serves as a heat diffuser to spread out the heat to avoid having a center hot spot. Keep in mind that because of the high heat capacity of the outer burner, and the mass of the cast iron burner grates (they retain heat longer than lighter, conventional grates), some foods may continue to cook by retained heat after the burner has been turned off.

The simmer burner is lit from the outside burner flame.

The flame travels through the simmer ignition channels and crosses over onto the simmer burner located just beneath the simmer cap. When lighting only the simmer burner, always light the main burner first. This will in turn provide the ignition source for the simmer burner. Ensure that the simmer ports are lit before turning the control knob down to the simmer position. Should a strong draft or boilover extinguish the simmer flame, it will not relight automatically as the outer burner would.

Burner efficiency and flame characteristics

The burner flame should burn completely around and within the burner with no excessive noise or lifting. The flame should be blue in color and stable with no yellow tips.

An improper air-gas mixture may cause either a burner flutter or a yellow-tipped flame. A technician should adjust the flame.

During initial use, foreign particles in the gas line, or dust in the air or around the appliance may cause an orange flame. This will disappear with use.

Flame height

The correct height of the flame mainly depends on the size of the bottom of the cooking utensil, the material of the cooking utensil, the amount and type of food and the amount of liquid in the utensil.

For safe handling of cookware, never let the flame extend up the sides of the cookware. Any flame larger than the bottom of the cookware is wasted heat and only serves to heat the handle.

Watch the flame, not the knob, as you reduce the heat.

- For safety reasons the flame must never extend beyond the bottom of the cooking utensil. Never allow flames to curl up the side of the pan.
- Be very careful if the pans have plastic handles, as these large professional-size burners can flame up on the outside of the pan and melt or bubble the handles.
- Utensils which conduct heat slowly (such as glass-ceramic) should be used with medium to low flames. If you are cooking with a large amount of liquid, a slightly larger flame can be used.

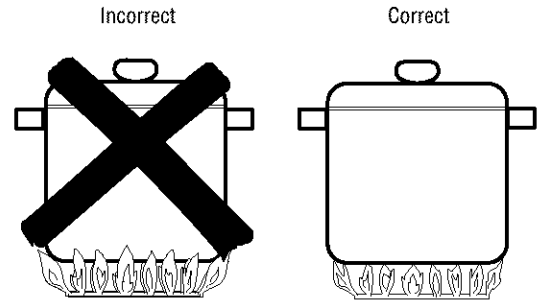

Note: The flame size on a gas burner should match the cookware you are using.

Power failure

The electric ignition that lights the surface burners will not operate during a power failure.

To light the surface burners during a power failure, turn the control knob for the burner you want to light to LITE while holding a lighted match to the outer ring. After the flame is burning all the way around the burner, adjust the flame.

It is necessary to light each burner separately each time you want to use it during a power failure.

The grille and griddle (on some models) can not be used during a power failure.

Cookware

Do not operate a burner for an extended period of time without cookware on the grate. The finish on the grate may chip without cookware to absorb the heat.

Aluminum: Medium-weight cookware is recommended because it heats quickly and evenly. Most foods brown evenly in an aluminum skillet. Use saucepans with tight-fitting lids for cooking with minimum amounts of water.

Cast Iron: If heated slowly, most skillets will give satisfactory results.

Enamelware: Under some conditions, the enamel of some cookware may melt. Follow cookware manufacturer's recommendations for cooking methods.

Glass: There are two types of glass cookware—those for oven use only and those for surface cooking (saucepans, coffee and teapots). Glass conducts heat very slowly.

Heatproof Glass-Ceramic: Can be used for either surface or oven cooking. It conducts heat very slowly and cools very slowly. Check cookware manufacturer's directions to be sure it can be used on gas cooktops.

Stainless Steel: This metal alone has poor heating properties, and is usually combined with copper, aluminum or other metals for improved heat distribution. Combination metal skillets generally work satisfactorily if they are used at medium heat as the manufacturer recommends.

Using the grille

(on some models)

Before starting to cook on the grille, be sure the drip tray and liners are in place and that you have the grille racks turned to the side you want for cooking.

Preheat the grille for 15 minutes with the control knob set on HI. When the grille is preheated, place the food on the grille. Cook it to the desired doneness.

NOTE: The longer you preheat the grille, the darker the grille marks will be on your food.

During cooking it may be necessary to adjust the heat setting. The control knob may be set to any position between HI and LO.

For proper searing and browning, the grille requires high heat.

With large pieces of meat or poultry, you may need to turn the heat to a lower heat setting after the food has been seared. This lower heat setting will allow the food to cook through without burning the outside.

Marinades and barbecue sauce should be added toward the end of cooking time. The heat should be turned to low when sauces are added.

Do not leave the grille unattended while it is on.

When you are finished cooking, allow the grille and the drip trays to cool before cleaning them. They should be cleaned each time they are used.

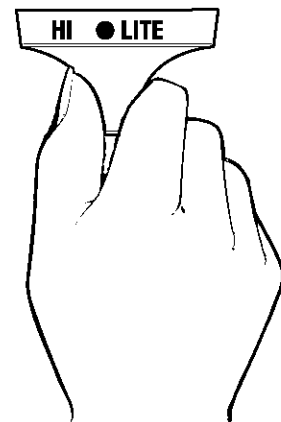

Excessive grille flare-ups and flaming

Occasionally grease drippings ignite. These drippings will create minor puffs of flame for a second or two. This is normal when cooking on a barbecue. You may find it handy to have a spray bottle filled with water to lightly spray the flare-up.

If the flame becomes excessive, remove the food from the grille. Lower the heat setting. Replace the food when the flare-up subsides.

To prevent flare-ups from happening, trim the fat from around the edges of steaks and chops, use hamburger that is lean, remove the fat from poultry, etc.

When turning any kind of meat or poultry, the melting fat will drop onto the briquettes and it may create a flare-up. If this happens, use a long-handled spatula to move the food to another area.

Grille rack

The two-piece rack is reversible. Place the side with the two grooved tabs toward the back of the cooktop. The grille rack is made of cast Type 304 stainless steel.

The rack will change color when subjected to the heat of the grille, and as oils cook onto the surface. This is normal and does not affect the cooking performance of the grille.

For best results, the rack should be seasoned before the first use. Seasoning will insure a stick-resistant cooking surface. If the grille has not been used for a period of time, it should be reseasoned.

To season the grill rack:

- 1 Clean the rack thoroughly with hot, soapy water to remove any manufacturing oils, etc.
- 2 Rinse with a mixture of 2 cups water and 1/2 cup white vinegar. Dry thoroughly.
- 3 Using a heavy cloth, rub vegetable oil over the entire surface of the rack. Do not use corn oil, as it gets sticky.
- 4 Place rack into the grille housing. Turn the burner on to a medium setting. Turn the burner off when the oil begins to smoke. Allow rack to cool.
- 5 Repeat steps 3 and 4.
- 6 Using a heavy cloth, apply a very thin layer of vegetable oil over the entire cooking surface. The grille is now ready for use.

One side of the grille (side A) is ridged and should be used for foods where you want the fat to run off, such as steak or hamburger patties. The ridges are sloped so the fat runs toward the front of the grille and can easily run down to the cooler area of the drip tray and away from the intense heat of the burner.

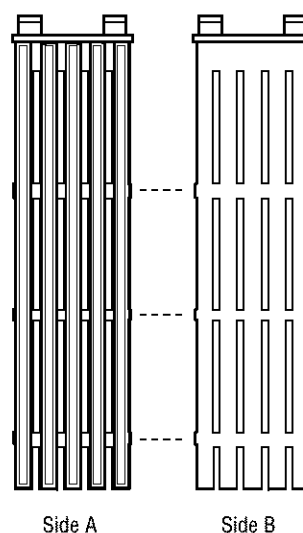

The other side of the grille (side B) was designed for foods that need more support while cooking, such as fish.

Food cooked on this grille achieves the same flavor as food cooked on an outdoor grille. The intense radiant heat from the ceramic briquettes caramelizes the fats and juices that are brought to the surface of the food, giving it the barbecued flavor.

This gas grille may cook slightly faster than you are used to.

Grilling hints

- When turning the meat over, always use a spatula as it will not puncture the meat, allowing the juices to run out. This will help to keep the meat juicy. Turn the meat only once, as juices are lost when the meat is repeatedly turned. Season or salt the meat after it has been cooked; these procedures have a tendency to dry the meat out.
- Be sure to trim any excess fat from meat or poultry. To prevent steaks or chops from curling while they are being cooked, slit the fat around the edges at about 2-inch intervals. To test for doneness, make a small cut in the center of the meat.
- The doneness of meat is affected by the thickness of the cut. It is impossible to cook a thin piece of meat to a rare doneness. A steak should be at least 1-inch thick to have it turn out rare and juicy. The cooking time is affected by the temperature of the meat when you start to cook it, the size and shape of the cut and the kind of meat you are cooking. The degree of doneness desired also affects the time.
- The U.S. Department of Agriculture says, "Rare beef is popular, but you should know that cooking it to only 140°F. means some food poisoning organisms may survive." (Source: Safe Food Book. Your Kitchen Guide. USDA Rev. June 1985.)

Before using the griddle (on some models)

The built-in griddle is made from Type 304 stainless steel, highly polished to provide a smooth cooking surface. It is normal for it to darken with use as oils cook onto the surface to provide a stick-resistant base or "seasoning." Since the griddle is made from stainless steel, the surface will not rust.

The griddle is thermostatically controlled and cycles on and off to maintain the set temperature. The "HEATING" light indicates that the burner is on.

The griddle assembly is not to be removed for cleaning and is held in place by three rear screws. These screws keep the griddle from shifting in transit, and are also used for positioning to avoid breaking ignition components.

Once the unit is in position, the rear center shipping screw can be removed. It is located beneath the griddle flue cover. Remove the flue cover by lifting it straight up.

The two outer screws are leveling screws. **Do not remove these two screws.** They can be turned to level the griddle or to provide a forward slope to help grease and oils to drain away from the food being cooked. After using the griddle a few times, you will be able to judge the slope best for the foods you are cooking and your personal preference.

When replacing the griddle flue cover, ensure that the cover slips to the outside of the front and back metal flanges of the fixed griddle assembly. This will ensure a tight fit of the flue cover.

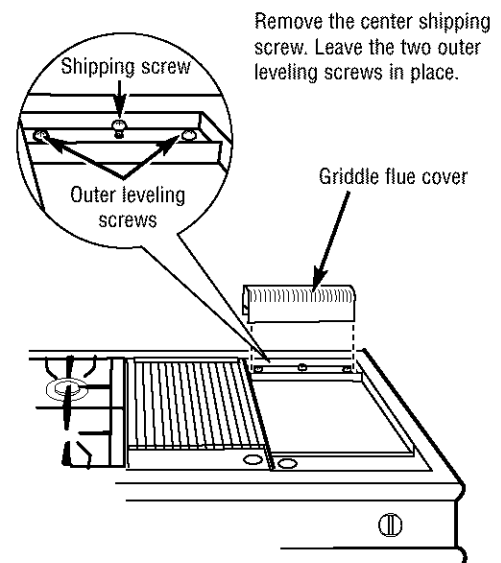

Seasoning the griddle

Before using the griddle for the first time, it must be seasoned.

If the griddle has not been used for a period of time, it should be reseasoned.

To season the griddle:

- 1** Clean the griddle thoroughly with hot, soapy water to remove any protective coating.
- 2** Rinse with a mixture of 1 quart water and 1 cup white vinegar. Dry thoroughly.
- 3** Pour 1 teaspoon vegetable oil into the center of the griddle. Do not use corn oil as it gets sticky. Rub the oil over the entire surface of the griddle using a heavy cloth.

4 Turn the control knob to a medium setting (350°F.). Turn the heat off when the oil begins to smoke. Allow the griddle to cool.

5 Repeat step 3. Be sure to cover the entire surface with the oil.

6 Repeat step 4. Allow the griddle to cool. Wipe the entire surface of the griddle using a heavy cloth. Apply a very thin layer of vegetable oil. The griddle is now ready to use.

Using the griddle

Before starting to cook on the griddle, be sure the drip tray and liners are in place. Preheat the griddle for 15 minutes with the control knob set to the temperature suggested on the Griddle Cooking Chart. When the griddle is preheated, the HEATING light will turn off. Place the food on the griddle and cook to the desired doneness.

NOTE: When the griddle is properly seasoned, it can be used without any additional shortening. However, shortening can be used for flavor. A light mist of a non-stick vegetable spray, applied before cooking to a cool griddle, makes delicate foods easier to turn.

Control panel and knobs

Clean up spatters with a damp cloth. Remove heavier soil with warm, soapy water.

Do not use abrasives of any kind on the control panel.

The control knobs may be removed for easier cleaning. To remove a knob, pull it straight off the stem. Wash the knobs in soap and water but do not soak.

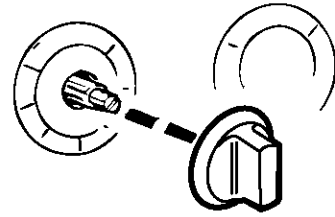

Grille

(on some models)

Clean the grille immediately after cooking. Turn off the burner. To protect your hand from steam and heat, wear a barbecue mitt. Scrub the grille by dipping a brass bristle barbecue brush frequently into a bowl of water.

The steam created softens the food particles and assists the cleaning process. The food particles will drop into the drip tray or into the radiant tray holding the ceramic briquettes. Be sure to clean the drain tube, drip tray and liner after they have cooled.

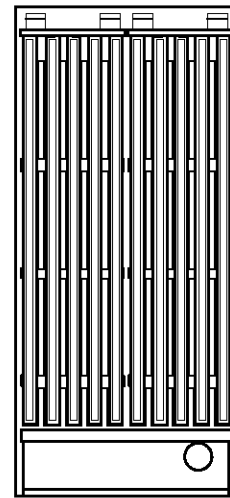

Ceramic briquettes

(on some models)

The layer of ceramic briquettes, under the grille racks, will last for many years with proper care.

Burned-on food particles and ash can be emptied off the radiant tray when cool by shaking over a waste receptacle.

Chipping or cracking of the briquettes may occur as they may get brittle with age, depending on the frequency of use. This is normal and does not affect the performance.

Do not replace the radiant tray/briquettes with alternates.

Stainless steel

Do not use a steel wool pad; it will scratch the surface.

To clean the stainless steel surface, use a hot, damp cloth with a mild detergent suitable for stainless steel surfaces. Use a clean, hot, damp cloth to remove soap. Dry with a dry, clean cloth.

If food soil remains, try a general kitchen cleaner, such as Fantastik®, Simple Green® or Formula 409®.

For hard-to-clean soil, use a standard stainless steel cleaner, such as Bon-Ami® or Cameo.

Apply cleaner with a damp sponge. Use a clean, hot, damp cloth to remove cleaner. Dry with a dry, clean cloth. Always scrub lightly in the direction of the grain.

After cleaning, use a stainless steel polish, such as Stainless Steel Magic®, Revere Copper and Stainless Steel Cleaner® or Wenol All Purpose Metal Polish®. Follow the product instructions for cleaning the stainless steel surface.

*Drip trays,
drip tray
liners and
drain tubes*

The drip tray or trays (depending on model) are located under the cooktop. If you have a griddle or a grille there will also be a tray liner. The drip trays and liners are made of stainless steel. The drip trays are on rollers so they are easy to remove and replace.

To remove the drip tray, pull it forward. If something has spilled into the tray it should be cleaned up as soon as possible to prevent “baked on” food soil.

Grease from the griddle or the grille drains through the drain tubes into the tray and into the liner below.

Do not allow the grease to accumulate in the drip tray or liner as it can be a fire hazard. Clean the drip tray and liner as soon as they are cool. Clean with hot soapy water.

To clean the drain tube use a soapy bottle brush. A mild abrasive cleaner such as Bon-Ami® or Soft Scrub® can be used. For stubborn stains, use a soap-filled steel wool pad or a harsh abrasive cleaner such as Comet® or Ajax®, rubbing lightly. Rinse all parts thoroughly.

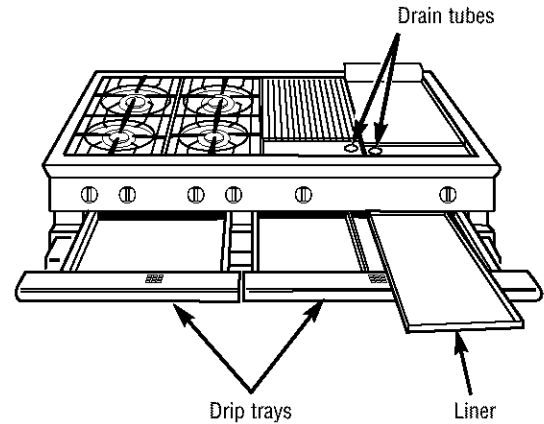

*Griddle
(on some models)*

Thoroughly clean the griddle of grease and food particles, using a square-edged spatula, while it is still hot.

Wipe the griddle with a dry heavy coarse cloth to remove any remaining residue and food particles.

Wash with hot soapy water, rinse and dry.

Once the griddle has cooled rub the surface lightly with vegetable oil. Do not use corn oil as it gets sticky.

If the griddle is cleaned with anything other than a dry heavy coarse cloth, it will need to be reseasoned.

Never flood the hot griddle with cold water. This could cause the griddle to crack or warp.



Burner assembly

The burner assemblies should be washed regularly and, of course, after spillovers.

Turn all the controls to OFF before removing the burner parts.

The electrode of the spark ignitor is exposed beyond the top of the burner. When cleaning the burner tray, be careful not to snag the electrode of the spark ignitor with your cleaning cloth. Do not hit the spark ignitor. Be careful not to turn on any surface controls while cleaning the burner tray. A slight electrical shock might result which could cause you to knock over hot cookware.

The burner grates and burner caps can be lifted off, making them easy to clean. Removing them gives you access to the burner bases.

To avoid snagging cloth on the spark ignitors, leave burner caps in place when cleaning the burner tray.

The burners have been designed in two pieces for ease of cleaning. When the burner grate and the burner are cool, remove the grate. The burner caps can easily be lifted off. Wash these parts in hot soapy water, rinse and dry thoroughly.

A bristle brush can be used to clean out the burner ports, if necessary.

The burner grates are porcelain enamel. When cool, they may be wiped clean using hot, soapy water, then rinsed and wiped dry. When lifting the burner grates, be careful as they are heavy. Place them on a protected surface so they won't scratch the surface of the cooktop.

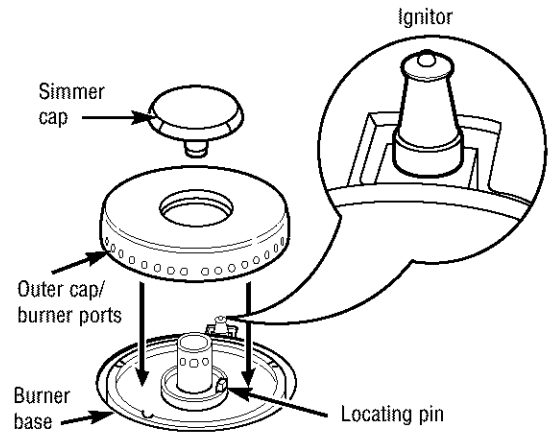

CAUTION:

Do not operate the burner without all burner parts in place.

After cleaning, it is important to make sure the indentation on the bottom side of the outer cap/burner port is properly aligned with the corresponding locating pin in the burner base. Incorrect alignment will produce poor burner performance.

The Problem Solver

Stainless Steel Cooktop

*Questions?
Use this
problem
solver!*

PROBLEM	POSSIBLE CAUSE
BURNERS DO NOT LIGHT	<ul style="list-style-type: none">• Burners assembled incorrectly after cleaning. Make sure the burner assembly is put together correctly and that the outer caps/burner ports are aligned.• Ports blocked in the outer cap near the ignitor. Clean and reassemble. See “Burner assembly” in the Care and Cleaning section.• Inspect the manual cut-off valve to insure that it is not closed.• Make sure the electrical plug is plugged into a live power outlet.• Check for a power outage.
BURNER FLAMES VERY LARGE OR YELLOW	<ul style="list-style-type: none">• Improper air/gas ratio in burners. Call for service.
TICKING SOUND OF SPARK IGNITOR AFTER BURNER LIGHTS	<ul style="list-style-type: none">• The spark ignitor is not deactivated. Turn the burner OFF and relight. Some ticking is normal. If ticking is excessive, call for service.
STRONG ODOR	<ul style="list-style-type: none">• Improper air/gas ratio in burners. Call for service.

With the purchase of your new Monogram appliance, receive the assurance that if you ever need information or assistance from GE, we'll be there. All you have to do is call—toll-free!

GE Answer Center®

800.626.2000

Whatever your question about any Monogram major appliance, GE Answer Center® information service is available to help. Your call—and your question—will be answered promptly and courteously. And you can call any time. GE Answer Center® service is open 24 hours a day, 7 days a week.

OR

Visit our Website at: www.monogram.com

In-Home Repair Service

800-444-1845

A GE consumer service professional will provide expert repair service, scheduled at a time that's convenient for you. Many GE Consumer Service company-operated locations offer you service today or tomorrow, or at your convenience (7:00 a.m. to 7:00 p.m. weekdays, 9:00 a.m. to 2:00 p.m. Saturdays). Our factory-trained technicians know your appliance inside and out—so most repairs can be handled in just one visit.

For Customers With Special Needs...

800.626.2000

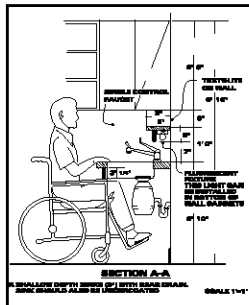

GE offers, free of charge, a brochure to assist in planning a barrier-free kitchen for persons with limited mobility.

Consumers with impaired hearing or speech who have access to a TDD or a conventional teletypewriter may call 800.TDD.GEAC (800.833.4322) to request information or service.

Service Contracts

800-626-2224

You can have the secure feeling that GE Consumer Service will still be there after your warranty expires. Purchase a GE contract while your warranty is still in effect and you'll receive a substantial discount. With a multiple-year contract, you're assured of future service at today's prices.

Parts and Accessories

800-626-2002

Individuals qualified to service their own appliances can have parts or accessories sent directly to their home. The GE parts system provides access to over 47,000 parts...and all GE Genuine Renewal Parts are fully warranted. VISA, MasterCard and Discover cards are accepted.

User maintenance instructions contained in this manual cover procedures intended to be performed by any user. Other servicing generally should be referred to qualified service personnel. Caution must be exercised, since improper servicing may cause unsafe operation.

YOUR MONOGRAM COOKTOP WARRANTY

Staple sales slip or cancelled check here. Proof of original purchase date is needed to obtain service under warranty.

WHAT IS COVERED

FULL ONE-YEAR WARRANTY

For one year from date of original purchase, we will provide, free of charge, parts and service labor in your home to repair or replace **any part of the cooktop** that fails because of a manufacturing defect.

.....

LIMITED FIVE-YEAR WARRANTY

For five years from the date of original purchase, we will provide, free of charge, replacement **gas surface burners** if they fail in normal household use. (The grille and griddle burners are not included.) You pay for the service trip to your home and all service labor charges.

.....

This warranty is extended to the original purchaser and any succeeding owner for products purchased for ordinary home use in the 48 mainland states, Hawaii and Washington, D.C. In Alaska the warranty is the same except that it is LIMITED because you must pay to ship the product to the service shop or for the service technician's travel costs to your home.

All warranty service will be provided by our Factory Service Centers or by our authorized Customer Care® servicers during normal working hours.

Should your appliance need service, during warranty period or beyond, call 800.444.1845.

WHAT IS NOT COVERED

- Service trips to your home to teach you how to use the product.
 - Discoloration of the griddle plate
 - Chipping of porcelain enamel grates
 - Replacement of house fuses or resetting of circuit breakers.
 - Incidental or consequential damage caused by possible defects with this appliance.
 - Damage to the product caused by accident, fire, floods or acts of God.
 - Failure of the product if it is used for other than its intended purpose or used commercially.
 - Improper installation.
- If you have an installation problem, contact your dealer or installer. You are responsible for providing adequate electrical, gas, exhausting and other connecting facilities as described in the Installation Instructions provided with the product.
-

Some states do not allow the exclusion or limitation of incidental or consequential damages, so the above limitation or exclusion may not apply to you. This warranty gives you specific legal rights, and you may also have other rights which vary from state to state.

To know what your legal rights are in your state, consult your local or state consumer affairs office or your state's Attorney General.

Warrantor: General Electric Company. If further help is needed concerning this warranty, write: Manager—Consumer Affairs, GE Appliances, Louisville, KY 40225

ZGU36L6	ZGU36N4R	ZGU48L4G	ZGU48N6D
ZGU36N6	ZGU36L4D	ZGU48N4G	ZGU48L6R
ZGU36L4R	ZGU36N4D	ZGU48L6D	ZGU48N6R

**Consumer Product
Ownership Registration**
Important Mail Today

GE Appliances



Place
1st Class
Letter
Stamp
Here

General Electric Company
Warranty Registration Department
P.O. Box 32150
Louisville, KY 40232-2150

Consumer Product Ownership Registration

Dear Customer:

Thank you for purchasing our product and thank you for placing your confidence in us. We are proud to have you as a customer!

Follow these three steps to protect your new appliance investment:

1 Complete and mail your Consumer Product Ownership Registration today. Have the peace of mind of knowing we can contact you in the unlikely event of a safety modification.

2 After completing this registration, write your model and serial numbers in this manual. You will need this information should you require service. Our service number is 800.444.1845.

3 Read your Owner's Manual carefully. It will help you operate your new appliance properly.

Important: To ensure that your product is registered, mail the separate product registration card. If the separate product registration card is missing, fold and mail the form below. No envelope is needed.

FOLD HERE

Consumer Product Ownership Registration

Important
Mail
Today!

Product
Cooktop

Model

Serial

Mr. Ms. Mrs. Miss

First Name _____ Last Name _____

Street Address _____

Apt. # _____

City _____ State _____ Zip Code _____

Date Placed In Use Month _____ Day _____ Year _____ Phone Number _____-_____-_____



Occasionally, we may allow selected companies to send you information.
 Check here if you do not want this information.



TAPE CLOSED



Monogram.
We bring good things to life.

General Electric Company
Louisville, KY 40225

164D4290P030

49-80072-1

17381 05-02 JR

Printed in the United States