

# Owner's Manual

# CRAFTSMAN®

## RANDOM ORBIT SANDER

### Double Insulated

Model No.  
315.116360

Ryobi

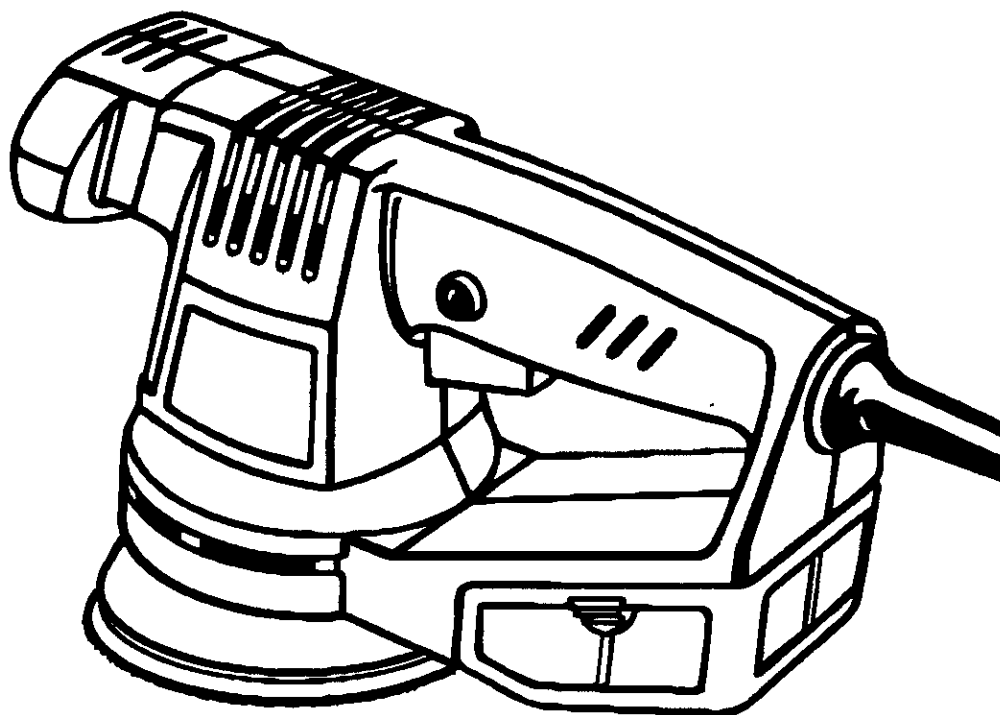

Save this manual for  
future reference

**⚠ CAUTION:** Read and follow  
all Safety Rules and Operating  
Instructions before first use of  
this product.

- Safety
- Features
- Operation
- Maintenance
- Parts List

Customer Help Line: 1-800-932-3188

Sears Roebuck and Co., 3333 Beverly Rd., Hoffman Estates, IL 60179 USA  
Visit the Craftsman web page: [www.sears.com/craftsman](http://www.sears.com/craftsman)

972000-952  
11-01



## TABLE OF CONTENTS

■ Table Of Contents .....	2
■ Warranty and Introduction .....	2
■ Rules For Safe Operation .....	3-5
■ Product Specifications and Unpacking .....	5
■ Features .....	6
■ Operation .....	7-9
■ Maintenance .....	10
■ Exploded View and Repair Parts List .....	12-13
■ Parts Ordering / Service .....	14

## WARRANTY

### FULL ONE YEAR WARRANTY ON CRAFTSMAN RANDOM ORBIT SANDER

If this **CRAFTSMAN** Random Orbit Sander fails to give complete satisfaction within one year from the date of purchase, **RETURN IT TO THE NEAREST SEARS STORE IN THE UNITED STATES**, and Sears will replace it, free of charge.

If this **CRAFTSMAN** Random Orbit Sander is used for commercial or rental purposes, this warranty applies for only 90 days from the date of purchase.

This warranty gives you specific legal rights, and you may also have other rights which vary from state to state.

**Sears, Roebuck and Co., Dept. 817WA, Hoffman Estates, IL 60179**

## INTRODUCTION

Your sander has many features for making sanding operations more pleasant and enjoyable. Safety, performance and dependability have been given top priority in the design of this sander making it easy to maintain and operate.

**CAUTION:** Carefully read through this entire owner's manual before using your new sander. Pay close attention to the Rules For Safe Operation, Warnings and Cautions. If you use your sander properly and only for what it is intended, you will enjoy years of safe, reliable service.

**Look for this symbol to point out important safety precautions. It means attention!!! Your safety is involved.**

### **WARNING**



The operation of any sander can result in foreign objects being thrown into your eyes, which can result in severe eye damage. Before beginning power tool operation, always wear safety goggles or safety glasses with side shields and a full face shield when needed. We recommend Wide Vision Safety Mask for use over eyeglasses or standard safety glasses with side shields, available at Sears Retail Stores. Always wear eye protection which is marked to comply with ANSI Z87.1.

## RULES FOR SAFE OPERATION

The purpose of safety symbols is to attract your attention to possible dangers. The safety symbols, and the explanations with them, deserve your careful attention and understanding. The safety warnings do not by themselves eliminate any danger. The instructions or warnings they give are not substitutes for proper accident prevention measures.

### SYMBOL MEANING



#### **SAFETY ALERT SYMBOL:**

Indicates danger, warning, or caution. May be used in conjunction with other symbols or pictographs.



**DANGER:** Failure to obey a safety warning will result in serious injury to yourself or to others.

Always follow the safety precautions to reduce the risk of fire, electric shock and personal injury.



**WARNING:** Failure to obey a safety warning can result in serious injury to yourself or to others.

Always follow the safety precautions to reduce the risk of fire, electric shock and personal injury.



**CAUTION:** Failure to obey a safety warning may result in property damage or personal injury to yourself or to others.

Always follow the safety precautions to reduce the risk of fire, electric shock and personal injury.

**NOTE:** Advises you of information or instructions vital to the operation or maintenance of the equipment.

### DOUBLE INSULATION

Double insulation is a concept in safety, in electric power tools which eliminates the need for the usual three-wire grounded power cord. All exposed metal parts are isolated from internal metal motor components with protecting insulation. Double insulated tools do not need to be grounded.



**WARNING:** Do not attempt to operate this tool until you have read thoroughly and understand completely all instructions, safety rules, etc. contained in this manual. Failure to comply can result in accidents involving fire, electric shock, or serious personal injury. Save owner's manual and review frequently for continuing safe operation, and instructing others who may use this tool.

### READ ALL INSTRUCTIONS

- **KNOW YOUR POWER TOOL.** Read owner's manual carefully. Learn its applications and limitations as well as the specific potential hazards related to this tool.
- **GUARD AGAINST ELECTRICAL SHOCK BY PREVENTING BODY CONTACT WITH GROUNDED SURFACES.** For example; pipes, radiators, ranges, refrigerator enclosures.

### IMPORTANT

Servicing of a tool with double insulation requires extreme care and knowledge of the system and should be performed only by a qualified service technician. For service we suggest you return the tool to your nearest Sears Store for repair. Always use original factory replacement parts when servicing.

- **KEEP GUARDS IN PLACE AND IN WORKING ORDER.**
- **KEEP WORK AREA CLEAN.** Cluttered areas and benches invite accidents.
- **AVOID DANGEROUS ENVIRONMENT.** Don't use power tools in damp or wet locations or expose to rain. Keep work area well lit.
- **KEEP CHILDREN AND VISITORS AWAY.** All visitors should wear safety glasses and be kept a safe distance from work area. Do not let visitors contact tool or extension cord.
- **STORE IDLE TOOLS.** When not in use, tools should be stored in a dry and high or locked-up place – out of the reach of children.
- **DON'T FORCE TOOL.** It will do the job better and safer at the rate for which it was designed.

## **RULES FOR SAFE OPERATION (Continued)**

- **USE RIGHT TOOL.** Don't force small tool or attachment to do the job of a heavy duty tool. Don't use tool for purpose not intended – for example – A circular saw should never be used for cutting tree limbs or logs.
- **WEAR PROPER APPAREL.** Do not wear loose clothing or jewelry that can get caught in tool's moving parts and cause personal injury. Rubber gloves and nonskid footwear are recommended when working outdoors. Wear protective hair covering to contain long hair and keep it from being drawn into nearby air vents.
- **ALWAYS WEAR SAFETY GLASSES.** Everyday eyeglasses have only impact-resistant lenses; they are not safety glasses.
- **PROTECT YOUR LUNGS.** Wear a face or dust mask if the operation is dusty.
- **PROTECT YOUR HEARING.** Wear hearing protection during extended periods of operation.
- **DON'T ABUSE CORD.** Never carry tool by cord or yank it to disconnect from receptacle. Keep cord from heat, oil, and sharp edges.
- **SECURE WORK.** Use clamps or a vise to hold work. It's safer than using your hand and it frees both hands to operate tool.
- **DON'T OVERREACH.** Keep proper footing and balance at all times. Do not use while standing on a ladder or unstable support. Secure tools when working at elevated positions.
- **MAINTAIN TOOLS WITH CARE.** Keep tools sharp and clean for best and safest performance. Follow instructions for lubricating and changing accessories.
- **DISCONNECT TOOLS.** When not in use, before servicing, or when changing or adjusting sanding belt, attachments, blades, bits, cutters, etc., all tools should be disconnected from power supply.
- **REMOVE ADJUSTING KEYS AND WRENCHES.** Form habit of checking to see that keys and adjusting wrenches are removed from tool before turning it on.
- **AVOID ACCIDENTAL STARTING.** Don't carry plugged-in tool with finger on switch. Be sure switch is off when plugging in.
- **MAKE SURE YOUR EXTENSION CORD IS IN GOOD CONDITION.** When using an extension cord, be sure to use one heavy enough to carry the current your product will draw. An undersized cord will cause a drop in line voltage resulting in loss of power and overheating. A wire gage size (A.W.G.) of at least 16 is recommended for an extension cord 100 feet or less in length. A cord exceeding 100 feet is not recommended. If in doubt, use the next heavier gage. The smaller the gage number, the heavier the cord.
- **OUTDOOR USE EXTENSION CORDS.** When tool is used outdoors, use only extension cords suitable for use outdoors. Outdoor approved cords are marked with the suffix W-A, for example - SJTW-A or SJOW-A.
- **NEVER USE THIS OR ANY POWER SANDER FOR WET SANDING.** Failure to comply can result in electrical shock causing serious injury or worse.
- **KEEP HANDS AWAY FROM SANDING AREA.**
- **NEVER USE IN AN EXPLOSIVE ATMOSPHERE.** Normal sparking of the motor could ignite fumes.
- **INSPECT TOOL CORDS PERIODICALLY** and if damaged, have repaired at your nearest Sears Repair Center. Stay constantly aware of cord location and keep it well away from the sanding area.
- **INSPECT EXTENSION CORDS PERIODICALLY** and replace if damaged.
- **KEEP HANDLES DRY, CLEAN, AND FREE FROM OIL AND GREASE.** Always use a clean cloth when cleaning. Never use brake fluids, gasoline, petroleum-based products, or any strong solvents to clean your tool.
- **STAY ALERT AND EXERCISE CONTROL.** Watch what you are doing and use common sense. Do not operate tool when you are tired. Do not rush.
- **CHECK DAMAGED PARTS.** Before further use of the tool, a guard or other part that is damaged should be carefully checked to determine that it will operate properly and perform its intended function. Check for alignment of moving parts, binding of moving parts, breakage of parts, mounting and any other conditions that may affect its operation. A guard or other part that is damaged should be properly repaired or replaced by an authorized service center.
- **DO NOT USE TOOL IF SWITCH DOES NOT TURN IT ON AND OFF.** Have defective switches replaced by an authorized service center.
- **INSPECT FOR** and remove all nails from lumber before sanding.
- **DO NOT** operate this tool while under the influence of drugs, alcohol, or any medication.

- **POLARIZED PLUGS.** To reduce the risk of electric shock, this tool has a polarized plug (one blade is wider than the other). This plug will fit in a polarized outlet only one way. If the plug does not fit fully in the outlet, reverse the plug. If it still does not fit, contact a qualified electrician to install the proper outlet. Do not change the plug in any way.
- **WHEN SERVICING USE ONLY IDENTICAL CRAFTSMAN REPLACEMENT PARTS.**
- **SAVE THESE INSTRUCTIONS.** Refer to them frequently and use them to instruct others who may use this tool. If you loan someone this tool, loan them these instructions also.

**⚠ WARNING:** Collected sanding dust from sanding surface coatings such as polyurethanes, linseed oil, etc., can self-ignite in your sander dust bag or elsewhere and cause fire. To reduce the risk of fire, always empty your dust bag frequently (10-15 minutes) while sanding and never store or leave a sander without totally emptying its dust bag. Also follow the recommendations of the coatings manufacturers.

**⚠ WARNING:** Some dust created by power sanding, sawing, grinding, drilling, and other construction activities contains chemicals known to cause cancer, birth defects or other reproductive harm. Some examples of these chemicals are:

- lead from lead-based paints,
- crystalline silica from bricks and cement and other masonry products, and
- arsenic and chromium from chemically-treated lumber.

Your risk from these exposures varies, depending on how often you do this type of work. To reduce your exposure to these chemicals: work in a well ventilated area, and work with approved safety equipment, such as those dust masks that are specially designed to filter out microscopic particles.

## SAVE THESE INSTRUCTIONS

### PRODUCT SPECIFICATIONS

Sanding Disc Diameter	5 in.	Input	120 volts, AC, 60 Hz only
No Load Speed	13,000 opm	Rating	3.0 Amperes
Diameter of Orbit	5/32 in.	Net Weight	3.5 lbs.

### UNPACKING

Your sander has been shipped completely assembled. Inspect it carefully to make sure no breakage or damage has occurred during shipping. If any parts are damaged or missing, contact your nearest Sears Retail Store to obtain replacement parts before attempting to operate sander. A sanding disc pack and this owner's manual are included in the box.

**⚠ WARNING:** If any parts are missing, do not operate this tool until the missing parts are replaced. Failure to do so could result in possible serious personal injury.

## FEATURES

### KNOW YOUR SANDER

See Figure 1.

Before attempting to use any tool, familiarize yourself with all operating features and safety requirements.

Your sander is suitable for sanding with coarse, medium, and fine grit sanding discs.

Features include easily operated lock-on button, and a dust box for dustless sanding.

### SWITCH

To turn your sander **ON**, depress the switch trigger. Release switch trigger to turn your sander **OFF**.

### ELECTRICAL CONNECTION

Your sander has a precision built electric motor. It should be connected to a **power supply that is 120 volts, 60 Hz, AC only (normal household current)**. Do not operate this tool on direct current (DC). A substantial voltage drop will cause a loss of power and the motor will overheat. If your sander does not operate when plugged into an outlet, double-check the power supply.

### RANDOM ORBIT

The random orbit motion provides overlapping sanding movements by combining orbital and turning motion. These overlapping sanding movements provide fast cutting action with excellent sanding results.

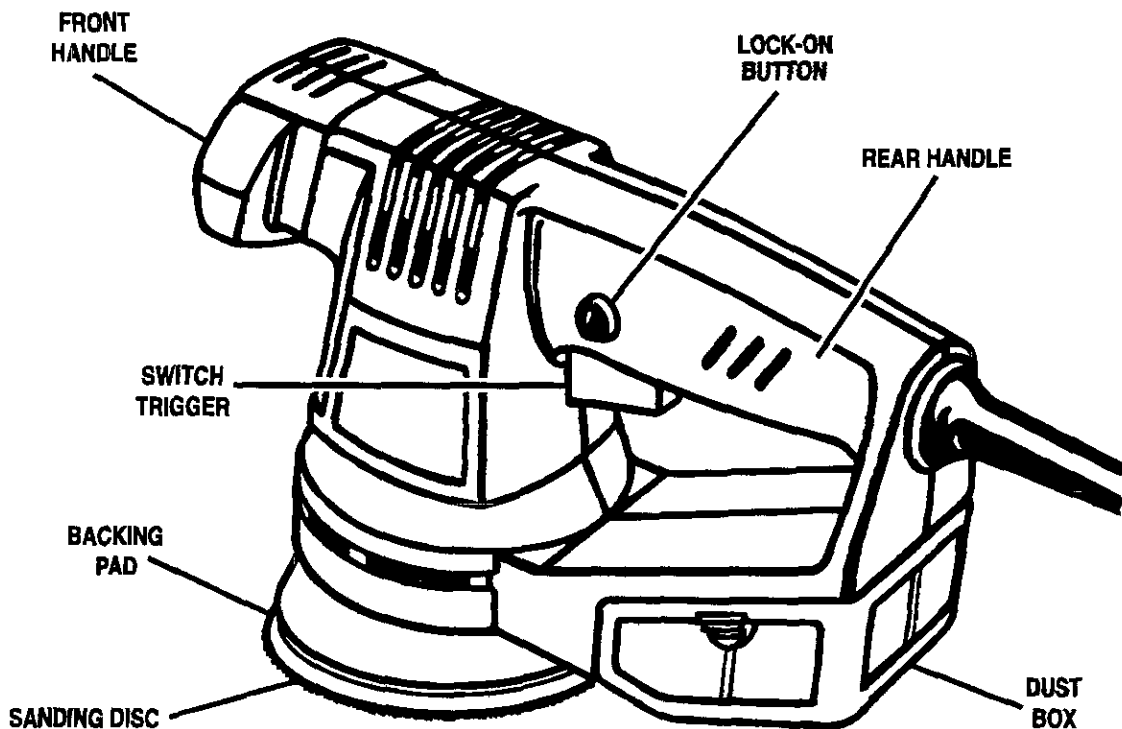

Fig. 1

**WARNING:** Do not allow familiarity with your sander to make you careless. Remember that a careless fraction of a second is sufficient to inflict severe injury.

## OPERATION

**WARNING:** Always wear safety goggles or safety glasses with side shields when operating your sander. Failure to do so could result in foreign objects being thrown into your eyes resulting in possible serious injury.

### LOCK-ON BUTTON

See Figure 2.

Your sander is equipped with a "lock-on" feature, which is convenient when continuous sanding for extended periods of time is required. **To lock-on**, depress the switch trigger, push in and hold the lock-on button located on the side of the handle, then release switch trigger. Release lock-on button and your sander will continue running. **To release the lock**, depress switch trigger and release it.

If you have the "lock-on" feature engaged during use and your sander becomes disconnected from power supply, disengage the "lock-on" feature immediately.

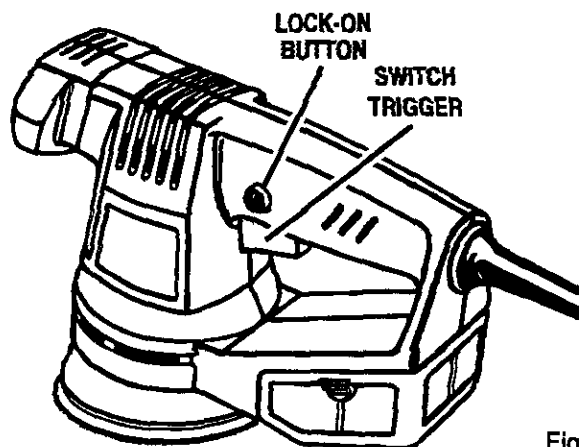

Fig. 2

**WARNING:** Your sander should never be connected to power supply when you are assembling parts, making adjustments, installing or removing sandpaper, when cleaning, or when not in use. Disconnecting your sander will prevent accidental starting that could cause serious injury.

**WARNING:** Do not wear loose clothing or jewelry when operating sander. They could get caught in moving parts causing serious injury. Keep head away from sander and sanding area. Hair could be drawn into sander causing serious injury.

### SANDING DISC SELECTION

Selecting the correct size grit and type sanding disc is an extremely important step in achieving a high quality sanded finish. Aluminum oxide, silicon carbide, and other synthetic abrasives are best for power sanding. Natural abrasives, such as flint and garnet are too soft for economical use in power sanding.

In general, coarse grit will remove the most material and finer grit will produce the best finish in all sanding operations. The condition of the surface to be sanded will determine which grit will do the job. If the surface is rough, start with a coarse grit and sand until the surface is uniform. Medium grit may then be used to remove scratches left by the coarser grit and finer grit used for finishing of the surface. Always continue sanding with each grit until surface is uniform.

### TO ATTACH SANDING DISC

See Figure 3.

■ Unplug your sander.

**WARNING:** Failure to unplug your sander could result in accidental starting causing serious injury.

- Carefully peel adhesive backing from new sanding disc.
- Align holes in sanding disc with holes in backing pad, then carefully press sticky side of disc against pad as tight as possible. **Note:** Holes in sanding disc must line up with holes in the backing pad in order for the dustless feature of your sander to function properly.

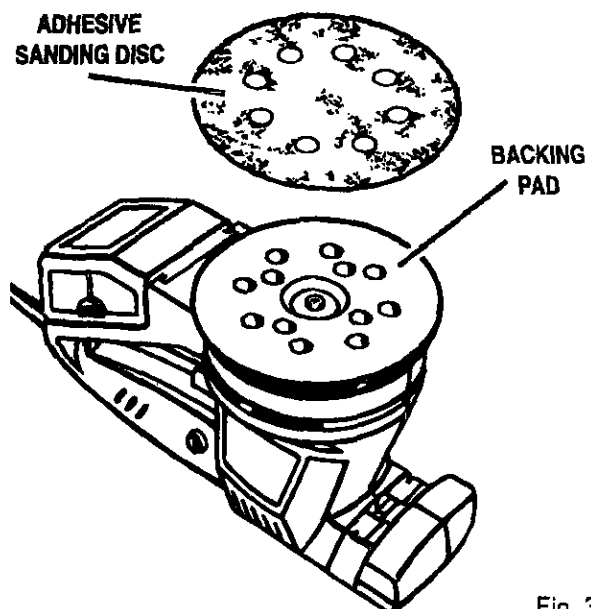

Fig. 3

## OPERATION

**⚠ WARNING:** Before connecting your sander to power supply source, always check to be sure it is not in lock-on position (depress and release switch trigger). Failure to do so could result in accidental starting of sander resulting in possible serious injury. Also, do not lock the trigger on jobs where your sander may need to be stopped suddenly.

### APPLICATIONS

(Use only for the purposes listed below)

- Sanding on wood surfaces.
- Removing rust from and sanding steel surfaces.

### PREPARING FOR OPERATION

For ease of operation, your sander has both a front handle and rear handle. See Figure 4. This provides for two-hand operation, which is necessary in order to maintain proper control of your sander and keep both hands clear of the sanding disc and sanding area. When operating your sander, always use both hands. See Figures 4 and 5.

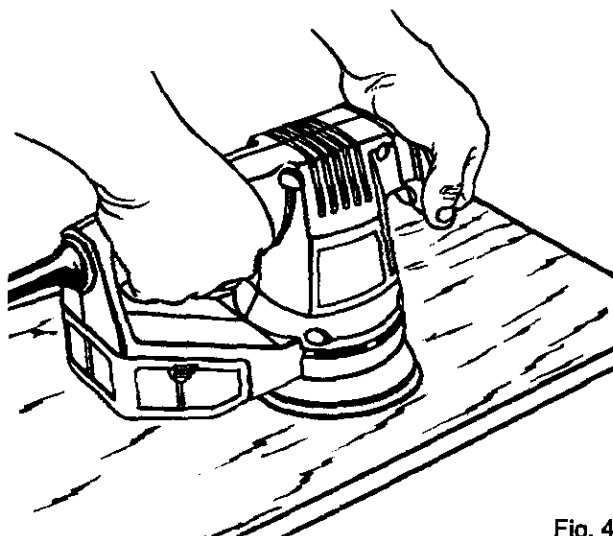

Fig. 4

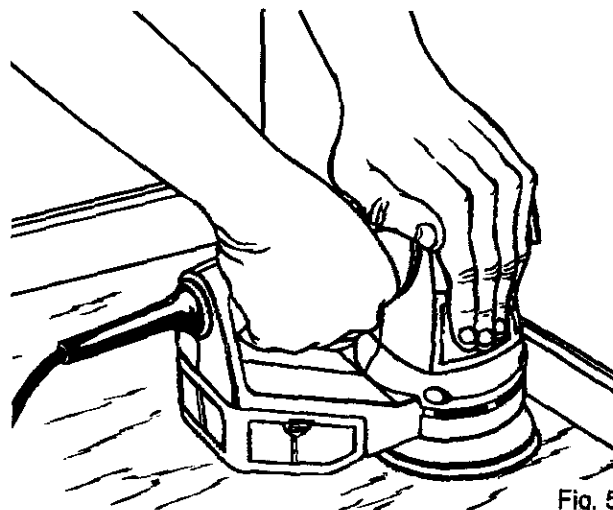

Fig. 5

Flush sanding can be performed with your sander when the front handle is removed from sander. See Figure 5. Remove front handle by depressing tab under front handle while pulling handle up and off of sander. See Figure 6.

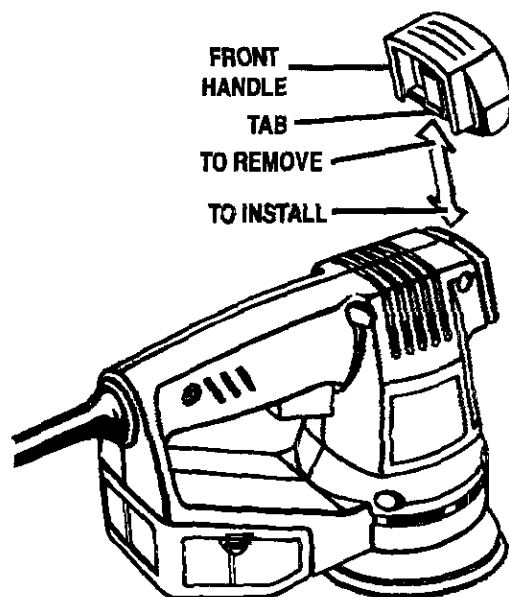

Fig. 6

### SANDING

Clamp or otherwise secure the work to prevent it from moving under your sander.

**⚠ WARNING:** Unsecured work could be thrown towards the operator causing injury.

Place sander on workpiece so that all of sanding disc surface is in contact with workpiece. Start your sander and move it slowly over workpiece making successive passes in parallel lines, circles, or crosswise movements. Upon completion of sanding operation, turn sander off and wait until sanding disc comes to a complete stop before removing from workpiece.

**⚠ WARNING:** Your sander should only be on when entire surface of sanding disc is in contact with workpiece. Failure to follow this sanding procedure could result in loose sanding disc which could result in possible serious injury.

**Do not force.** The weight of the unit supplies adequate pressure, so let the sanding disc and sander do the work. Applying additional pressure only slows the motor, rapidly wears sanding disc and greatly reduces sander speed. Excessive pressure will overload the motor causing possible damage from motor overheating and can result in inferior work. Any finish or resin on wood may soften from the frictional heat. Do not allow sanding on one spot too long as the sander's rapid action may remove too much material, making the surface uneven.



## OPERATION

### SANDING (Continued)

Extended periods of sanding as shown in Figure 5 may tend to overheat the motor. If this occurs, turn sander off and wait until sanding disc comes to a complete stop, then remove it from workpiece. Remove your hand from vent area and let motor cool.

### DUSTLESS SANDING

The dust box located on the rear of your sander provides a dust collection system for your sander. Sanding dust is drawn up through the holes of the sanding disc to collect in the dust box during sanding operation. For more efficient operation, empty dust box when half full.

### REMOVING DUST BOX

See Figure 7.

- To release dust box, depress tabs located on each side of dust box.
- Slide dust box down and lift from sander as shown by the arrows in figure 7.
- Do not press on the filter material with your hand or fingers. Filter material can be damaged.  
**Note:** Filter material is located on the sides of dust box.
- Do not break tabs that secure dust box to sander.
- Empty dust box.

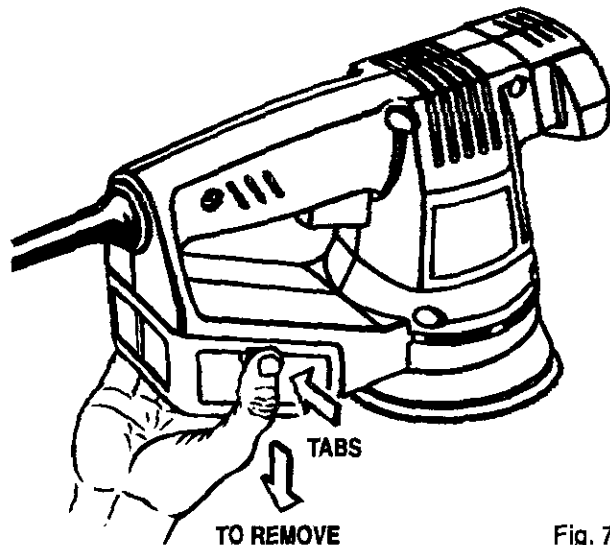

Fig. 7

### TO INSTALL DUST BOX

See Figure 8.

- Realign dust box with rear of sander.
- Slide dust box on sander as shown in figure 8. You will feel a soft click as the tab snaps into place.  
**Note:** As mentioned above, be careful not to break the tabs that secure dust box to sander.

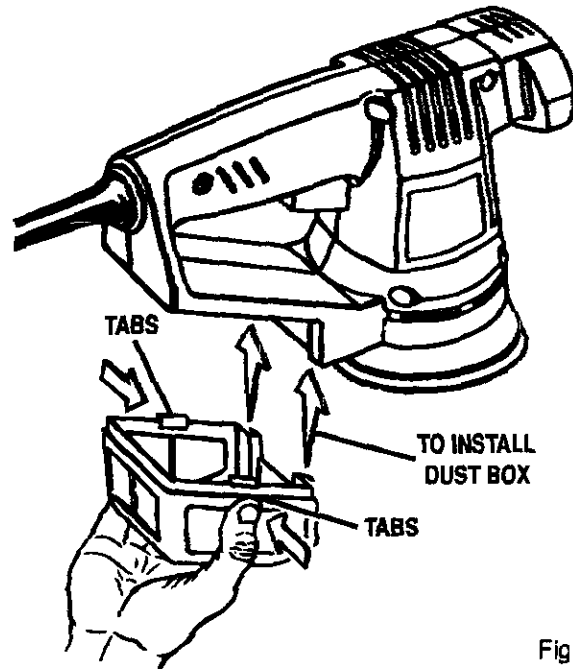

Fig. 8

### REMOVE SANDING DISC BEFORE STORAGE

Do not store your sander with a sanding disc installed. Heat generated from sanding causes the pressure sensitive adhesive to flow and form a tight bond between the backing pad and sanding disc.

Removing the sanding disc soon after you have finished a sanding operation avoids letting the adhesive set up. If the sanding disc is left on the backing pad for an extended period of time after use, the adhesive will set up and cause the sanding disc to become difficult to remove. It may also tear when removing. When this situation occurs, it becomes difficult to clean the backing pad for the next sanding disc.

**Note:** If you forget to remove the sanding disc after a sanding operation, sand for a few minutes to soften the adhesive backing before attempting to remove sanding disc.

**⚠ WARNING:** Do not use this product as a component of other products. Also, do not use attachments or accessories not recommended for use with this product. Any such use could result in possible serious personal injury.

## MAINTENANCE

**WARNING:** When servicing, use only identical Craftsman replacement parts. Use of any other part may create a hazard or cause product damage.

### GENERAL

Only the parts shown on parts list, page 13, are intended to be repaired or replaced by the customer. All other parts represent an important part of the double insulation system and should be serviced only by a qualified Sears service technician.

Avoid using solvents when cleaning plastic parts. Most plastics are susceptible to damage from various types of commercial solvents and may be damaged by their use. Use clean cloths to remove dirt, carbon dust, etc.

**WARNING:** Do not at any time let brake fluids, gasoline, petroleum-based products, penetrating oils, etc. come in contact with plastic parts. They contain chemicals that can damage, weaken or destroy plastic.

It has been found that electric tools are subject to accelerated wear and possible premature failure when they are used on fiberglass boats, sports cars, wallboard, spackling compounds, or plaster. The chips and grindings from these materials are highly abrasive to electric tool parts such as bearings, brushes, commutators, etc. Consequently, it is not recommended that this tool be used for extended work on any fiberglass material, wallboard, spackling compounds, or plaster. During any use on these materials it is extremely important that the tool is cleaned frequently by blowing with an air jet.

**WARNING:** Always wear safety goggles or safety glasses with side shields during power tool operation or when blowing dust. If operation is dusty, also wear a dust mask.

### LUBRICATION

All of the bearings in this tool are lubricated with a sufficient amount of high grade lubricant for the life of the unit under normal operating conditions. Therefore, no further lubrication is required.

### EXTENSION CORDS

The use of any extension cord will cause some loss of power. To keep the loss to a minimum and to prevent tool overheating, use an extension cord that is heavy enough to carry the current the tool will draw.

A wire gage size (A.W.G.) of at least 16 is recommended for an extension cord 100 feet or less in length. When working outdoors, use an extension cord that is suitable for outdoor use. The cord's jacket will be marked **WA**.

**CAUTION:** Keep extension cords away from the sanding area and position the cord so that it will not get caught on lumber, tools, etc., during sanding operation.

**WARNING:** Check extension cords before each use. If damaged replace immediately. Never use tool with a damaged cord since touching the damaged area could cause electrical shock resulting in serious injury.

Extension cords suitable for use with your sander are available at your nearest Sears Retail Store.



**CRAFTSMAN SANDER – MODEL NUMBER 315.116360**

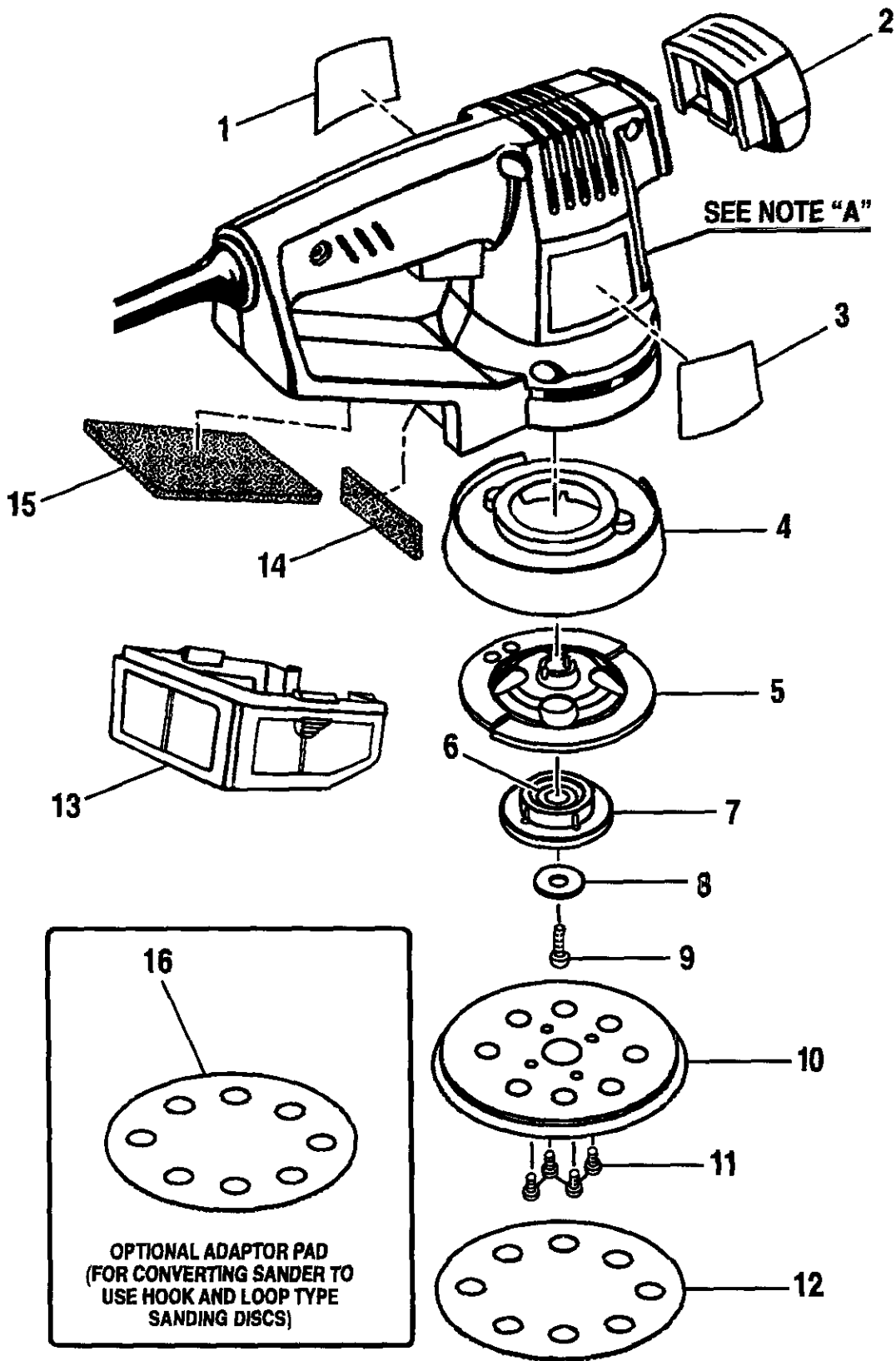

**NOTE: "A"** – The assembly shown represents an important part of the Double Insulated System. To avoid the possibility of alteration or damage to the system, service should be performed by your nearest Sears Repair Center. Contact your nearest Sears Retail Store for Service Center information.

## CRAFTSMAN SANDER – MODEL NUMBER 315.116360

The model number will be found on a plate attached to the motor housing. Always mention the model number in all correspondence regarding your CRAFTSMAN SANDER or when ordering repair parts.

**SEE BACK PAGE FOR PARTS ORDERING INSTRUCTIONS**

### PARTS LIST

Key No.	Part Number	Description	Quan.
1	983110-001	Logo Plate .....	1
2	969645-001	Front Handle .....	1
3	983109-001	Data Plate .....	1
4	973713-001	Skirt.....	1
5	973714-003	Counterbalance .....	1
6	969655-001	Ball Bearing (NTN 6002LLUC3/1E) .....	1
7	981439-000	Bearing Cap w/Bearing (Inc. Key No. 6) ....	1
8	703493-818	Washer .....	1
9	969649-001	* Screw (#8-32 x 1/2 in. Pan Hd.) .....	1
10	975241-002	5 in. Disc Assembly .....	1
11	606066-013	* Screw (#10-32 x 5/16 in. Pan Hd.) .....	4
12	***	Sanding Disc .....	1
13	969533-002	Dust Box .....	1
14	969896-001	Small Gasket .....	1
15	970099-002	Seal.....	1
16	974484-001	** Optional Adaptor Pad .....	1
	972000-952	Owner's Manual	

**\* Standard Hardware Item — May Be Purchased Locally**

**\*\* This Adaptor Pad May Be Purchased For Use With Hook And Loop  
Type Sanding Discs**

**\*\*\* Complete Assortment Available At Your Nearest Sears Retail Store**

For repair of major brand appliances **in your own home...**  
no matter who made it, no matter who sold it!

**1-800-4-MY-HOME<sup>SM</sup>** Anytime, day or night  
(1-800-469-4663)

[www.sears.com](http://www.sears.com)

To bring in products such as vacuums, lawn equipment and electronics  
for repair, call for the location of your nearest **Sears Parts & Repair Center.**

**1-800-488-1222** Anytime, day or night

[www.sears.com](http://www.sears.com)

For the replacement parts, accessories and owner's manuals  
that you need to do-it-yourself, call **Sears PartsDirect<sup>SM</sup>!**

**1-800-366-PART** 6 a.m. – 11 p.m. CST,  
(1-800-366-7278) 7 days a week

[www.sears.com/partsdirect](http://www.sears.com/partsdirect)

To purchase or inquire about a Sears Service Agreement:

**1-800-827-6655**

7 a.m. – 5 p.m. CST, Mon. – Sat.

Para pedir servicio de reparación a domicilio,  
y para ordenar piezas con entrega a domicilio:

**1-888-SU-HOGAR<sup>SM</sup>**  
(1-888-784-6427)

Au Canada pour service en français:

**1-877-LE-FOYER<sup>SM</sup>**  
(1-877-533-6937)

**SEARS**  
HomeCentral<sup>TM</sup>