

Digital Palmcorder®
MultiCam™ Camcorder

Panasonic®

Digital Video Camcorder
Operating Instructions

Model No. **PV-DV203**

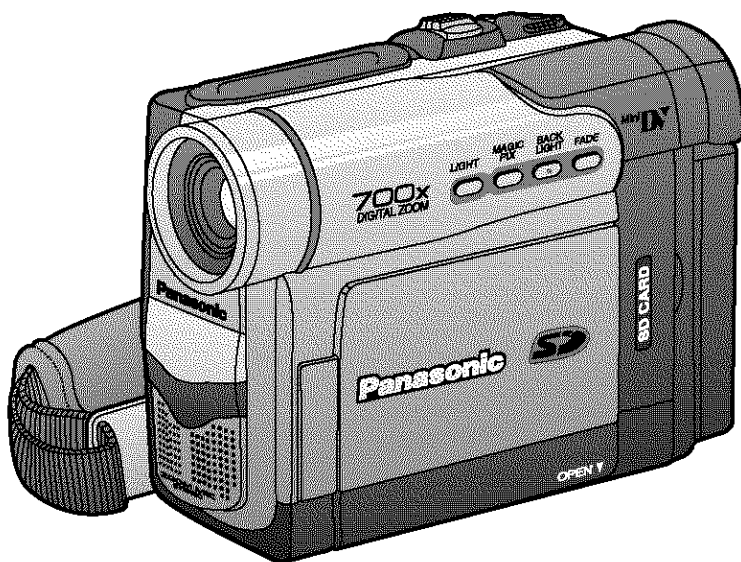

MultiMediaCard™



Mini **DV**

Before attempting to connect, operate or adjust this product, please read these instructions thoroughly.

Spanish Quick Use Guide is included.

Guía para rápida consulta en español está incluida.

For assistance, please call : 1-800-211-PANA(7262) or send e-mail to : consumerproducts@panasonic.com

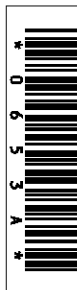

LSQT0653A

Things You Should Know

Thank you for choosing Panasonic!

You have purchased one of the most sophisticated and reliable products on the market today. Used properly, we're sure it will bring you and your family years of enjoyment. Please take time to fill in the information below. The serial number is on the tag located on the underside of your Palmcorder. Be sure to **retain this manual** as your convenient Palmcorder information source.

Date of Purchase

Dealer Purchased From

Dealer Address

Dealer Phone No.

Model No.

Serial No.

Safety Precautions

WARNING: TO PREVENT FIRE OR SHOCK HAZARD, DO NOT EXPOSE THIS EQUIPMENT TO RAIN OR MOISTURE.

Your Mini DV Palmcorder is designed to record and play back in Standard Play (SP) mode and Long (LP) mode.

It is recommended that only cassette tapes that have been tested and inspected for use in VCR machines with the Mini DV mark be used.



CAUTION

**RISK OF ELECTRIC SHOCK
DO NOT OPEN**



This symbol warns the user that uninsulated voltage within the unit may have sufficient magnitude to cause electric shock. Therefore, it is dangerous to make any kind of contact with any inside part of this unit.

**CAUTION: TO REDUCE THE RISK OF ELECTRIC SHOCK,
DO NOT REMOVE COVER (OR BACK)
NO USER-SERVICEABLE PARTS INSIDE
REFER SERVICING TO QUALIFIED SERVICE PERSONNEL**



This symbol alerts the user that important literature concerning the operation and maintenance of this unit has been included. Therefore, it should be read carefully in order to avoid any problems.

The above markings are located on the appliance bottom cover.

Declaration of Conformity

Model Number : **PV-DV203**
Trade Name : **Panasonic**
Responsibility Party : **Matsushita Electric Corporation of America**
Address : **One Panasonic Way Secaucus New Jersey 07094**
Telephone Number : **1-800-211-PANA(7262)**

This device complies with Part 15 of the FCC Rules. Operation is subject to the following two conditions: (1) This device may not cause harmful interference, and (2) this device must accept any interference received, including interference that may cause undesired operation.

Note: This equipment has been tested and found to comply with Part 15 of the FCC Rules. These limits are designed to provide reasonable protection against harmful interference when operated in a residential environment.

If this equipment does cause interference to radio or television reception, which can be determined by turning the equipment off and on, use the equipment in another location and/or utilize an electrical outlet different from that used by the receiver.

If necessary, consult the dealer or an experienced radio/TV technician for help. You may find the booklet, 'Something About Interference' available from FCC local regional offices helpful.

FCC Warning: To assure continued FCC compliance, use only the provided shielded interface cable when connecting digital video camcorder to computer in accordance with instruction herein. Also, any unauthorized changes or modifications to this equipment would void the user's authority to operate.

1. **Read Instructions** — All the safety and operating instructions should be read before the unit is operated.
2. **Retain Instructions** — The safety and operating instructions should be retained for future reference.
3. **Heed Warnings** — All warnings on the unit and in the operating instructions should be adhered to.
4. **Follow Instructions** — All operating and maintenance instructions should be followed.
5. **Cleaning** — Unplug this video unit from the wall outlet before cleaning. Do not use liquid or aerosol cleaners. Use a dry cloth for cleaning.
6. **Attachments** — Do not use attachments not recommended by the video product manufacturer as they may be hazardous.
7. **Water and Moisture** — Do not use this video unit near water — for example near a bath tub, wash bowl, kitchen sink, or laundry tub, in a wet basement, or near a swimming pool, and the like.
8. **Accessories** — Do not place this video unit on an unstable cart, stand, tripod, bracket, or table. The video unit may fall, causing serious injury to a child or adult, and serious damage to the unit. Use only with a cart, stand, tripod, bracket, or table recommended by the manufacturer, or sold with the video unit. Any mounting of the unit should follow the manufacturer's instructions and should use a mounting accessory recommended by the manufacturer. An appliance and cart combination should be moved with care. Quick stops, excessive force, and uneven surfaces may cause the appliance and cart combination to overturn.
9. **Ventilation** — Slots and openings in the cabinet are provided for ventilation and to ensure reliable operation of the video unit and to protect it from overheating. These openings must not be blocked or covered. Never place the video unit on a bed, sofa, rug, or other similar surface, or near or over a radiator or heat register. This video unit should not be placed in a built-in installation such as a bookcase or rack unless proper ventilation is provided or the manufacturer's instructions have been adhered to.
10. **Power Sources** — This video unit should be operated only from the type of power source indicated on the marking label. If you are not sure of the type of power supply to your home, consult your appliance dealer or local power company. For video units intended to be operated from battery power, or other sources, refer to the operating instructions.



11. **Grounding or Polarization** — This video unit may be equipped with either a polarized 2-wire AC (Alternating Current) line plug (a plug having one blade wider than the other) or 3-wire grounding type plug, a plug having a third (grounding) pin.
The 2-wire polarized plug will fit into the power outlet only one way. This is a safety feature. If you are unable to insert the plug fully into the outlet, try reversing the plug. If the plug still fails to fit, contact your electrician to replace your obsolete outlet. Do not defeat the safety purpose of the polarized plug.
The 3-wire grounding type plug will fit into a grounding type power outlet. This is a safety feature. If you are unable to insert the plug into the outlet, contact your electrician to replace your obsolete outlet. Do not defeat the safety purpose of the grounding type plug.
12. **Power-Cord Protection** — Power-supply cords should be routed so that they are not likely to be walked on or pinched by items placed upon or against them, paying particular attention to cords of plugs, convenience receptacles, and the point where they exit from the unit.
13. **Outdoor Antenna Grounding** — If an outside antenna or cable system is connected to the video unit, be sure the antenna or cable system is grounded so as to provide some protection against voltage surges and built-up static charges. Part 1 of the Canadian Electrical Code, in USA Section 810 of the National Electrical Code, provides information with respect to proper grounding of the mast and supporting structure, grounding of the lead-in wire to an antenna discharge unit, size of grounding conductors, location of antenna discharge unit, connection to grounding electrodes, and requirements for the grounding electrode.

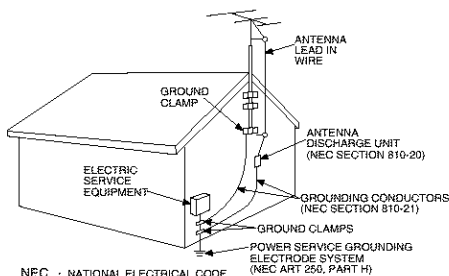

14. **Lightning** — For added protection of this video unit receiver during a lightning storm, or when it is left unattended and unused for long periods of time, unplug it from the wall outlet and disconnect the antenna or cable system. This will prevent damage to the video unit due to lightning and power-line surges.

Important Safeguards

15. Power Lines — An outside antenna system should not be located in the vicinity of overhead power lines or other electric light or power circuits, or where it can fall into such power lines or circuits. When installing an outside antenna system, extreme care should be taken to keep from touching such power lines or circuits as contact with them might be fatal.
16. Overloading — Do not overload wall outlets and extension cords as this can result in a risk of fire or electric shock.
17. Objects and Liquids — Never push objects of any kind into this video unit through openings as they may touch dangerous voltage points or short out parts that could result in a fire or electric shock. Never spill liquid of any kind onto the video unit.
18. Servicing — Do not attempt to service this video unit yourself as opening or removing covers may expose you to dangerous voltage or other hazards. Refer all servicing to qualified service personnel.
19. Damage Requiring Service — Unplug this video unit from the wall outlet and refer servicing to qualified service personnel under the following conditions:
 - a. When the power-supply cord or plug is damaged.
 - b. If any liquid has been spilled into, or objects have fallen onto, the video unit.
 - c. If the video unit has been exposed to rain or water.
 - d. If the video unit does not operate normally by following the operating instructions. Adjust only those controls that are covered by the operating instructions, as an improper adjustment of other controls may result in damage and will often require extensive work by a qualified technician to restore the video unit to its normal operation.
 - e. If the video unit has been dropped or the cabinet has been damaged.
 - f. When the video unit exhibits a distinct change in performance — this indicates a need for service.
20. Replacement Parts — When replacement parts are required, be sure the service technician has used replacement parts specified by the manufacturer or have the same characteristics as the original part. Unauthorized substitutions may result in fire, electric shock or other hazards.
21. Safety Check— Upon completion of any service or repairs to this video unit, ask the service technician to perform safety checks to determine that the video unit is in safe operating order.



Precautions

USE & LOCATION

- **TO AVOID SHOCK HAZARD ...** Your Palmcorder and power supply should not be exposed to rain or moisture. Do not connect the power supply or operate your Palmcorder if it gets wet. Your Palmcorder has been designed for outdoor use, however, it is not designed to sustain direct exposure to water, rain, sleet, snow, sand, dust, or direct splashing from a pool or even a cup of coffee. This action could permanently damage the internal parts of your Palmcorder. Do not attempt to disassemble this unit. There are no user serviceable parts inside. Unplug your Palmcorder from the power supply before cleaning.
- **DO NOT AIM YOUR PALMCORDER AT THE SUN OR OTHER BRIGHT OBJECTS**
- **DO NOT LEAVE THE PALMCORDER WITH THE EVF AIMED DIRECTLY AT THE SUN AS THIS MAY CAUSE DAMAGE TO THE INTERNAL PARTS OF THE EVF**
- **DO NOT EXPOSE YOUR PALMCORDER TO EXTENDED HIGH TEMPERATURE ...** Such as, direct sunlight, inside a closed car, next to a heater, etc... This action could permanently damage the internal parts of your Palmcorder.
- **AVOID SUDDEN CHANGES IN TEMPERATURE ...** If the unit is suddenly moved from a cold place to a warm place, moisture may form on the tape and inside the unit.
- **DO NOT LEAVE YOUR PALMCORDER OR THE POWER SUPPLY TURNED ON WHEN NOT IN USE.**
- **STORAGE OF YOUR PALMCORDER ...** Store and handle your Palmcorder in a manner that will not subject it to unnecessary movement (avoid shaking and striking). Your Palmcorder contains a sensitive pick-up device which could be damaged by improper handling or storage.

CARE

- **TO CLEAN YOUR PALMCORDER ...** Do not use strong or abrasive detergents when cleaning your Palmcorder body.
- **TO PROTECT THE LENS ...** Do not touch the surface of the lens with your hand. Use a commercial Palmcorder lens solution and lens paper when cleaning the lens. Improper cleaning can scratch the lens coating.
- **TO PROTECT THE FINISH OF YOUR PALMCORDER ...** Before handling your Palmcorder, make sure your hands and face are free from any chemical products, such as suntan lotion, as it may damage the finish.

Things You Should Know	2
Important Safeguards	3
Precautions	4
Before Using	6
• Easy Cassette Eject/Insertion	7
Quick Guide	12
Supplying Power	15
Setting the Clock	17
Using the Palmcorder Menu	18
<hr/>	
Camera Recording	19
• Simple Recording	19
• Digital PhotoShot™ Mode	21
• Zoom	22
Special Effect Features	24
Advanced Settings	28
<hr/>	
Playback Your Recordings	32
Special Effect Features	34
<hr/>	
Digital Features	40
Editing Features	45
Card Features	49
 PC Connection	
• Transferring Your Images (Windows)	56
• PHOTOVU/MPEG4 Movie Messenger™ System	60
• Transferring Your Images (i.LINK) (Windows)	72
• PHOTOVU/MPEG4 Movie Messenger™ System (i.LINK)	73
• Palmcorder USB Device Driver/SD Drive	75
• Palmcorder File Converter	78
• Web Camera (For Windows XP users/For Windows 98SE, Me, 2000 users)	80
• Warning Indications	89
 PC Connection	
• Transferring Your Images (Macintosh)	90
<hr/>	
Palmcorder Accessory System	92
Palmcorder Accessory Order Form	93
Notes On Operations	94
Specifications	97
Before Requesting Service	98
On-Screen Displays (OSD)	100
Request for Service Notice	101
Limited Warranty	102
Customer Services Directory	103
Spanish Quick Use Guide/Guía Para Uso Rápido	104
MENU OSD	108
Electronic Viewfinder/LCD Monitor Indications	113
Index of Controls	117
Index	Back Cover

Unpack your Palmcorder

1 pc. AC Adaptor (PV-DAC11)
with AC Cable and DC Cable

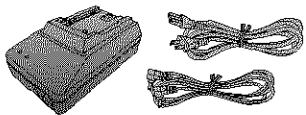

1 pc. 8 MB Memory Card
(RP-SD008BMK0)



1 pc. Battery Pack
(CGR-D08/CGR-D08R)

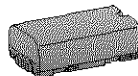

1 pc. A/V Cable (LSJA0280)



1 pc. Lens Cap (LSYF0535)
with Lens Cap Strap
(LSGQ0066)



1 pc. Shoulder Strap
(LSFC0016)



1 pc. USB Cable
(K1HA05CD0001)

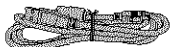

1 pc. CR2025 Clock Battery
(installed in Palmcorder)



1 pc. CD-ROM of Driver Software for Windows 98SE/Me/2000/XP and Macintosh; USB Device Driver for Windows 98SE/Me/2000/XP; PHOTOVU/MPEG4 Movie Messenger™ System for Windows 98SE/Me/2000/XP; Built-in SD Drive for Macintosh (LSFT0527)

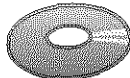

Microsoft®, Windows® and Windows Media are registered trademarks of Microsoft in the United States and other countries.
Macintosh, iMac, iBook, PowerBook, Power Macintosh, Power Mac, and Mac are trademarks or registered trademarks of Apple Computer, Inc.
Intel® Pentium® is a registered trademark.
i.LINK is a trademark.
PHOTOVU/MPEG4 Movie Messenger™ System is a registered trademark.
IBM is a registered trademark of IBM Company.
MultiMediaCard is a registered trademark.
SD is a trademark.

Record Speed/Playback Time

Use only those tapes having the ^{Mini} DV logo indicating the 6.35 mm digital standard.

Cassette type	Record Speed/ Playback time	
	SP	LP
AY-DVM30EJ	30 minutes	45 minutes
AY-DVM60EJ	60 minutes	90 minutes
AY-DVM80EJ	80 minutes	120 minutes

Erase Protection

Cassettes have a sliding record tab to ensure recordings are not accidentally erased.

1 To prevent accidental erasure:
Slide the tab to the left (open).

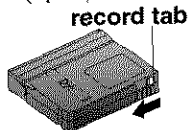

2 To record again:
Slide the tab to the right (close).



Easy Cassette Eject/Insertion

- If the Palmcorder is connected to a power source, the cassette can be inserted and ejected without turning the Palmcorder on.

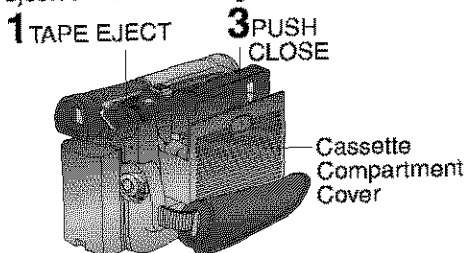

Note

- When inserting the cassette, make sure it is facing the right direction and then push it in completely.
- If Hand Strap is tight it may prevent Cassette Holder from fully opening for Cassette insert or eject. Loosen Hand Strap if necessary.

Attaching the Shoulder Strap

- 1 Undo the two strap ends from their buckles.

- 2 Thread the strap end through the Strap Attachment Rings.
 - Tilt Viewfinder upward.

- 3 Reinsert the strap ends through their buckles.
 - Make sure the straps are not twisted.

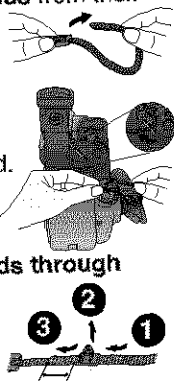

Adjust the Length

- 1 Loosen the strap from the Buckle and create a loop.
- 2 Pull the strap firmly through the Buckle to shorten or lengthen the strap.

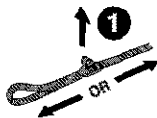

Before you begin

- Connect the Palmcorder to a power source. (pp. 15, 16)

- 1 Slide **TAPE EJECT** to open the Cassette Compartment Cover.
- 2 Insert a cassette record tab up, window side facing out.
- 3 Press **PUSH CLOSE** to close the Cassette Compartment Cover.

- **To remove the cassette...**
Slide **TAPE EJECT** to open the Cassette Compartment Cover and pull the cassette tape straight out.

Hand Strap

Adjust the length of the Hand Strap to the size of your hand as illustrated.

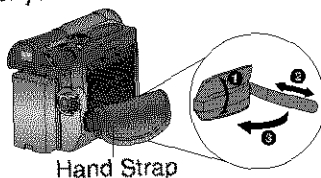

Lens Cap

Attaching the Lens Cap Strap:

Thread the Lens Cap Strap through the Strap Attachment Ring as shown.

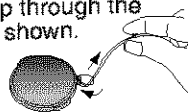

Attaching the Lens Cap Strap to the Hand Strap:

Remove the Hand Strap from the front clasp and thread the Strap through the loop in the Lens Cap Strap. Reattach the Hand Strap.

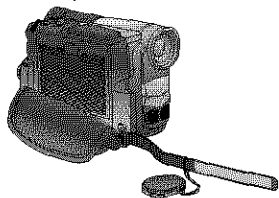

Using EfficiBright™ LED Light

To brighten the natural colors in a scene, GAIN UP works together with the LED Light to enhance the light's brightness.

Note

- Use LED Light for recording subjects 1.5 m (4.9 feet) away or closer.
- In the M-CARD mode, the GAIN UP mode cannot be set.

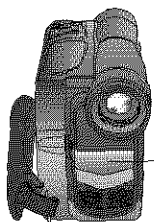
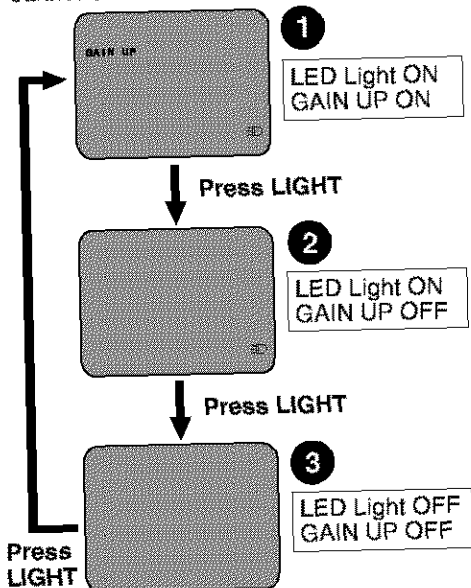

Built-in LED Light

1, 2, 3 LIGHT

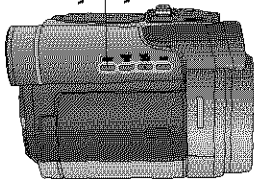

Before you begin

- Connect the Palmcorder to a power source. (pp. 15, 16)
- Set POWER to CAMERA or M-CARD.

- 1** Press LIGHT. (Mode **1**)
- LED Light and GAIN UP turn ON.
 - GAIN UP ON will be brighter than when only LED Light is ON, however, ghost images will appear.

- 2** Press LIGHT. (Mode **2**)
- GAIN UP turns OFF.
 - To eliminate ghost images, use this mode.

- 3** Press LIGHT. (Mode **3**)
- LED Light turns OFF.
 - Pressing LIGHT again returns to **1**.

Note

- Using Light reduces battery time.
- Set LIGHT to OFF when not in use.
- Do not look directly into the light.
- If the LED Light is used with a Conversion Lens attached, a slight vignetting (darkening around edges) effect occurs on the screen.
- Using MagicPix at the same time will make conditions even brighter. (p. 41)

Remote Control (Optional)

You can operate the major functions of your Palmcorder from up to approximately 5 m (16 feet) away (indoors). Aim the IR Remote Control toward the front of the Palmcorder and press the desired buttons (Remote Sensor is located under the lens).

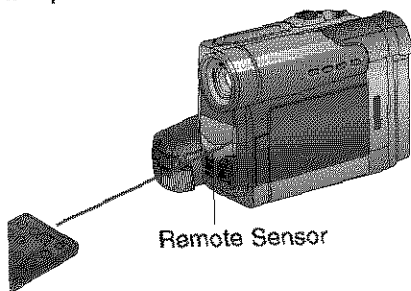

To operate Camera functions:

Set POWER to CAMERA.

To operate VCR functions:

Set POWER to VCR.

Controlled Functions

- Rec/Pause (p. 19)
- Tele (Zoom) (p. 22)
- Wide (Zoom) (p. 22)
- Date/Time (p. 113)
- Reset (p. 46)
- PhotoShot (p. 21)
- Display On TV (p. 39)
- Counter/Time Code (p. 114)
- Audio Dubbing (p. 45)
- Record (p. 48)
- Menu (pp. 18, 46)
- Play (pp. 32, 48)
- FF/Search (p. 34)
- REW/Search (p. 34)
- Pause/Select (p. 36)
- Stop/Set (pp. 17, 18, 32, 48)
- Slow/Frame Advance (Forward) (pp. 35, 36)
- Slow/Frame Advance (Backward) (pp. 35, 36)
- Index Search (Forward) (p. 37)
- Index Search (Backward) (p. 37)
- Speaker Volume (p. 33)

Replace the Battery

Optional

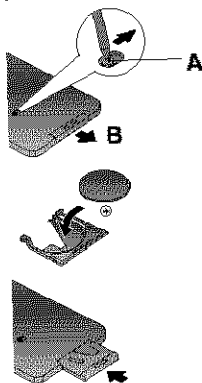

- 1** Insert a slender pointed object, such as the tip of a ball-point pen into the slot so that it fits into the hole (as shown **A**). Then, while sliding to the right, pull the Battery Tray out with your fingernail.
- 2** Insert the battery into the Battery Tray with the \oplus mark facing down.
Do not reverse the polarity.
- 3** Insert the Battery Tray.

Replace battery with Panasonic PART NO. VSBW0004 (CR2025) only. Use of another battery may present a risk of fire or explosion.
Caution: Battery may explode if mistreated. Dispose of used battery properly. Keep away from children. Do not recharge, disassemble or dispose of in a fire.

Remote Controlling Two Palmcorders

You can control any two Panasonic Palmcorders with one Remote Control (Optional). In order for the remote to distinguish between the two units, it is necessary to set one of the Palmcorders to VCR 2. On the remote, press VCR 1 or VCR 2 to control the desired Palmcorder.

3, 4
JOG KEY

2 MENU

1 POWER

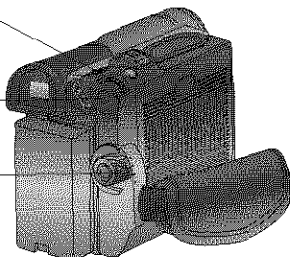

Optional

For VCR 2:
Press these buttons at the same time.

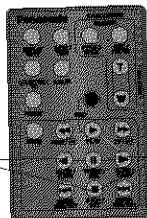

For VCR 1:
Press these buttons at the same time.

Note

- When the Palmcorder and remote are not set to the same mode (VCR1 or VCR2), "CHECK REMOTE MODE (REMOTE)" will appear.

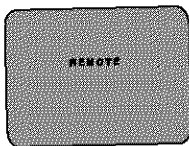

- 1** Set **POWER** to **VCR** or **CAMERA**.
 - The **POWER** Lamp lights red.
 - Be sure **POWER** is fully turned to **VCR** or **CAMERA** position.

- 2** Press **MENU** to display the **VCR** or **CAMERA** mode menu screen.

- 3** Rotate **JOG KEY** to select **OTHER FUNCTIONS** in the **CAMERA** or **VCR** mode menu screen, then press **JOG KEY** to display the **OTHER FUNCTIONS** menu screen.

- 4** Rotate **JOG KEY** to select **REMOTE**, and then press **JOG KEY** to select **VCR 2** (Menu OSD: pp. 109, 111). Leave the other Palmcorder set to **VCR 1**.

- 5** Set the Remote Control to **VCR 1** or **VCR 2** to correspond with the Palmcorder you wish to control. (See above left.)

- After replacing the Remote Control Battery, the remote will default to **VCR 1**.

Self Demo Mode

If no operation takes place for approx. 10 minutes after the AC Adaptor was connected to the Palmcorder and the POWER Switch was turned to CAMERA without inserting a Cassette, the Palmcorder is automatically set to Self Demo mode for introducing its function. To turn it off, follow steps 1~4 below.

[EVF or LCD Monitor]

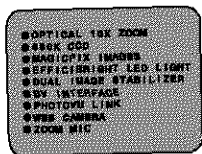

3, 4
JOG KEY

2 MENU

1 POWER

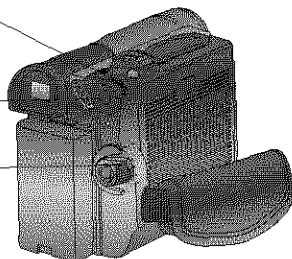

Before you begin

- Connect the Palmcorder to a power source. (pp. 15, 16)

1 Set POWER to CAMERA.

2 Press MENU to display the CAMERA FUNCTIONS menu screen.

3 Rotate JOG KEY to select OTHER FUNCTIONS, and press JOG KEY to display the OTHER FUNCTIONS menu screen.

4 Rotate JOG KEY to select DEMO MODE, and press JOG KEY to select OFF.
• Press MENU to exit.

Note

- If any button is pressed or operated (except PLAY/MULTI and ZOOM), the Self Demo mode is canceled.
- The Self Demo mode can be started by setting DEMO MODE to ON and by exiting the menu.

To turn Self Demo back on:

- Set to DEMO MODE : ON in MENU screen.

Insert the Battery Pack

Before you begin

- Charge the Battery. (p. 15)

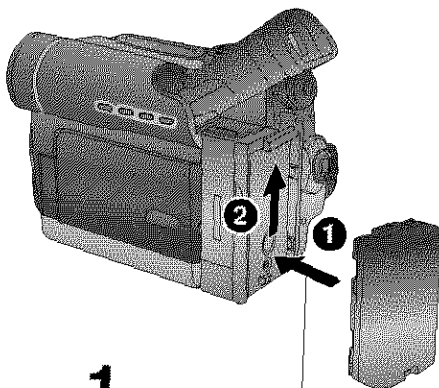

- 1** Insert the Battery Pack and slide it up until it locks with a click.

Insert Cassette

These Palmcorders are equipped with the Easy Cassette Eject System so it is easy to insert or remove tapes, even when the Palmcorder is on a tripod. (p. 7)

- 2** Slide **TAPE EJECT** to open the Cassette Compartment Cover.

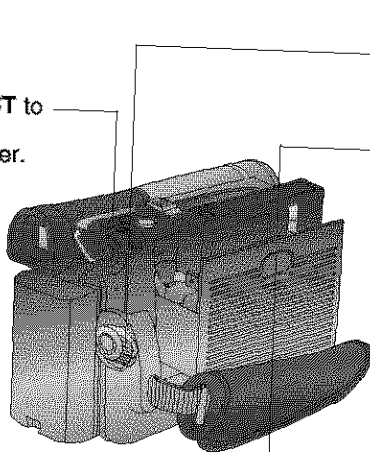

- 1** Set **POWER** to **VCR** or **CAMERA**.
- 3** Insert a cassette record tab up, window side facing out.
 - Make sure the record tab is closed. (p. 6)

- 4** Press **PUSH CLOSE** mark to close the Cassette Compartment Cover.

Camera Recording

When the LCD monitor is fully open, the Viewfinder automatically turns OFF.

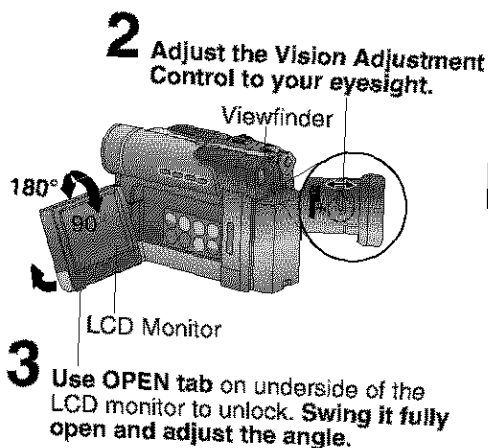
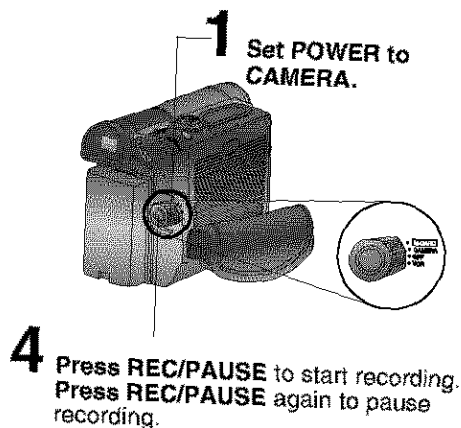

To Watch Playback in the LCD (Liquid Crystal Display)

When the LCD monitor is fully open, the Viewfinder automatically turns OFF.

Before you begin

- Charge the Battery. (p. 15)

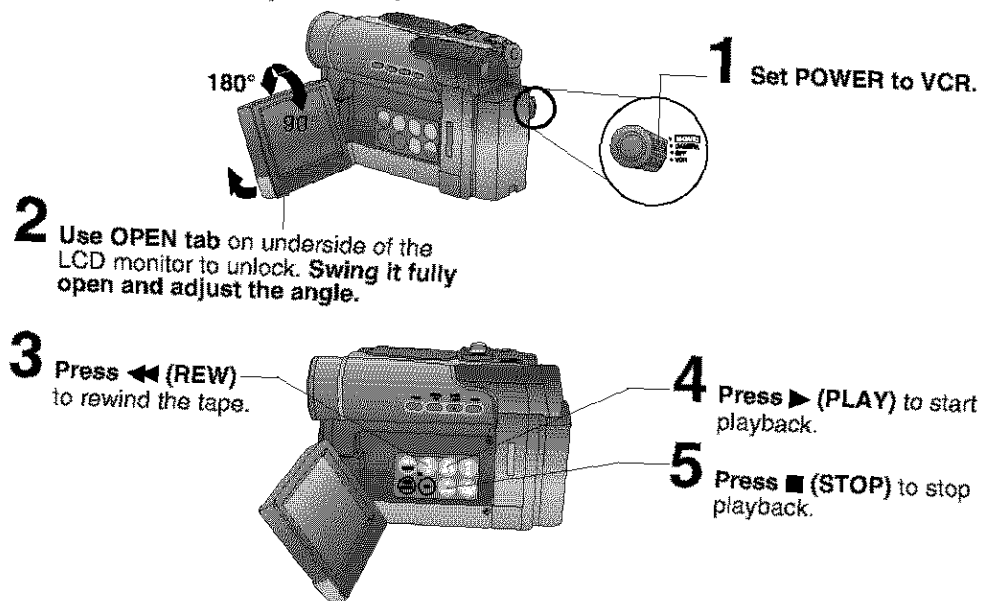

Insert Memory Card*

Before you begin

- Charge the Battery. (p. 15)

*Memory Card: MultiMediaCard or SD Memory Card (p. 94)

- Be sure to insert the Memory Card before using Card PhotoShot. (p. 49)

Below is a list of memory cards which can be used in this Palmcorder.

Memory Card	Capacity
SD Memory Card (RP-SD008BMK0) (supplied)	8 MB
MultiMediaCard (SanDisk brand)	8 MB, 16 MB
SD Memory Card (optional) (p. 92)	16 MB, 32 MB, 64 MB

SD Memory Card write protection switch



A write protection switch is located on the SD Memory Card. Sliding the switch to the "LOCK" position prevents writing on or formatting the card.

Write protection Switch

- 2** Open the Card Slot door.

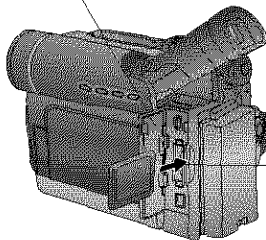

- 1** Set POWER to OFF.

- 3** Insert the Memory Card and gently push in until you hear a click.

- 4** Close the Card Slot door.

To remove the Memory Card...

Press here to eject the card.

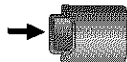

When inserting the Memory Card

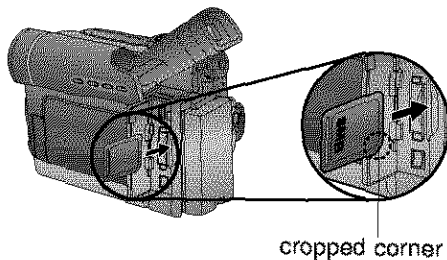

Note

- When inserting the Memory Card, insert with the cropped corner down as shown in the illustration above.

Charge the Battery Pack on the AC Adaptor

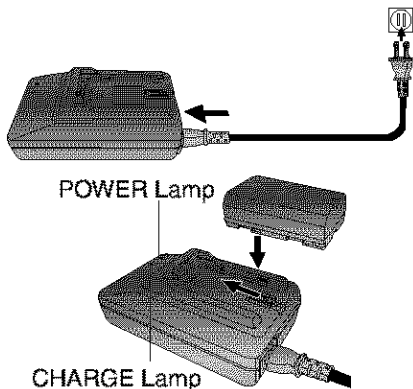

- 1** Connect and plug in the Power Cord as shown.
 - POWER Lamp will light.
 - Remove the DC Cable, if attached, from the adaptor.
- 2** Attach the Battery as shown to charge.
 - CHARGE Lamp lights up. It goes out when charging is complete (approx. 1 hour). Expect approx. 1 hour 50 minutes of operation (using EVF) when fully charged.
- 3** Remove the Battery. Slide the Battery out and then lift up.

Note

About the Flashing of the CHARGE Lamp

- Charge the Battery within an ambient temperature range of 10 °C (50 °F) and 30 °C (86 °F).
 - If charging is done in extreme low or high temperatures, Battery charge time increases.
- CHARGE Lamp flashes when...**
- The Battery is being charged, but charging is taking longer than normal.
 - Charging is not possible. Remove the Battery once, wait a short time, then re-attach it for charging.

Insert the Battery Pack

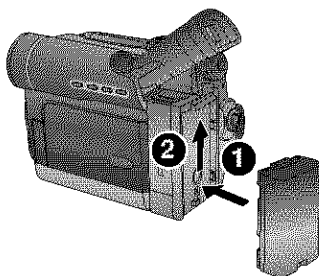

- 1** Insert the Battery Pack and slide it up until it locks with a click.

Remove the Battery Pack

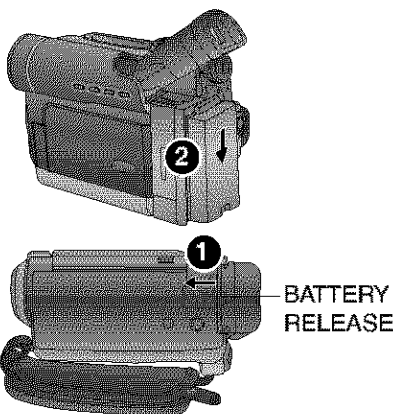

- 1** While sliding the BATTERY RELEASE, slide the Battery downward and remove.

Battery Care

Caution:

- Charge only with specified charger.
- Charge the Battery within an ambient temperature range of 10 °C (50 °F) and 30 °C (86 °F).
- The Battery may be warm after charging or just after use. This is normal.
- Do not use an insufficiently charged or worn out Battery.
- If charging is done in extreme low or high temperatures, Battery charge time increases.

Safety precautions:

- Do not place the Battery near, or dispose of in fire.
- Do not directly connect (short circuit) the positive (+) and negative (-) terminals.
- Never attempt to disassemble or reassemble the Battery.

To avoid damage to the Battery:

- Do not drop or jar the Battery.
- Use the Battery with specified models only.
- If the Battery is used in extremely high temperatures, a safety device will automatically prevent operation.

To ensure longer battery life:

- While not in use, remove Battery from the Palmcorder and AC Adaptor and store in a cool, dark, dry place. If you leave the Battery in the Palmcorder or on the AC Adaptor, the Battery will no longer be rechargeable.
- Keep the Battery terminals clean.

U.S.A. CONSUMERS: ATTENTION:



A lithium ion/polymer battery that is recyclable powers the product you have purchased. Please call 1-800-8-BATTERY for information on how to recycle this battery.

Use AC Adaptor

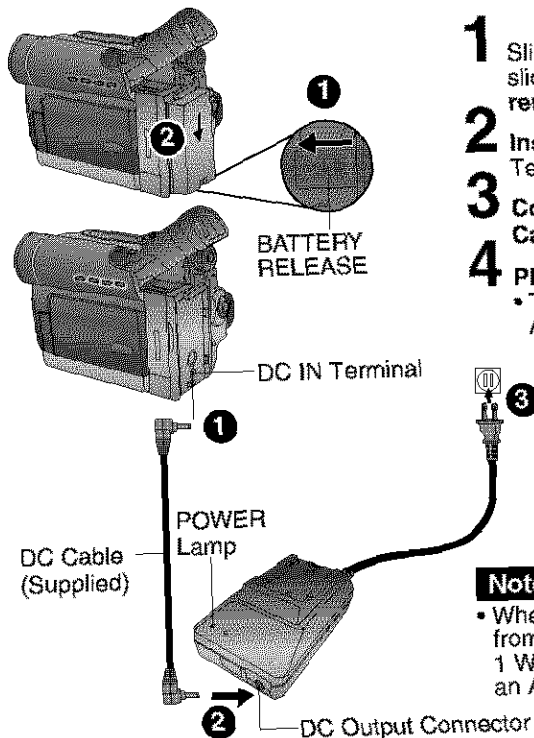

- 1** Slide the Battery downward while sliding **BATTERY RELEASE** to remove the **Battery Pack**. (p. 15)
- 2** Insert the **DC Cable** into the **DC IN Terminal**.
- 3** Connect the other end of the **DC Cable** to the **AC Adaptor** as shown.
- 4** Plug in the **AC Adaptor**.
 - The **POWER Lamp** on the **AC Adaptor** lights up.

Note

- When not in use, unplug the **AC Adaptor** from the **AC outlet**. (**AC Adaptor** consumes 1 W of electric power when plugged into an **AC outlet** even when not in use.)

Set the Date and Time

The date and time is calculated, including leap years, up to DEC 31 2089.

2, 3, 4
JOG KEY

1 MENU

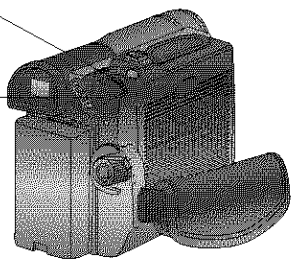

EXAMPLE:

YEAR	: 2003
↓	← PUSH →
	Push
MONTH	: JAN
↓	← PUSH →
	Rotate
MONTH	: FEB

Note

- To make corrections, Press JOG KEY repeatedly to move back to an item and correct.
- If "CLOCK BATTERY" indication appears, please refer to "Replacing Clock Battery" on page 95.

Before you begin

- Connect the Palmcorder to a power source. (pp. 15, 16)
- Set POWER to CAMERA or VCR.

1 Press **MENU** to display the Camera or VCR mode menu screen. (p. 18)



2 Rotate **JOG KEY** to select **OTHER FUNCTIONS**, and then press **JOG KEY** to display the OTHER FUNCTIONS menu screen.

3 Rotate **JOG KEY** to select **CLOCK SET**, and then press **JOG KEY** to set to ON. (Menu OSD: pp. 109, 111.)

- The CLOCK SET menu screen is displayed.

4 Rotate **JOG KEY** to select YEAR, then press **JOG KEY** to fix and move to the next item. Likewise, set the month, day, hour, and minute.



When **CLOCK SET** setting is completed, press **MENU** twice to start the clock and exit.

The Palmcorder features three menu displays: one for CAMERA mode (recording), one for M-CARD (Memory Card Photo Mode) and one for VCR mode (Playback). (pp. 108-112)

- While the Menu screen is displayed, you cannot record on or play a tape.
- While recording, the Menu screen cannot be displayed.
- During playback, the Menu screen can be displayed.

Before you begin

- Connect the Palmcorder to a power source. (pp. 15, 16)
- Set POWER to CAMERA or VCR.

2, A, B, C
JOG KEY

1, D
MENU

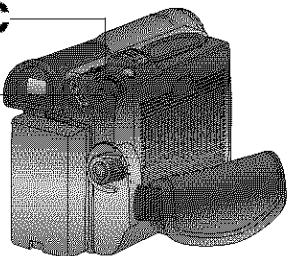

Displaying the MENU

- 1** Press **MENU** to display the CAMERA or VCR menu (according to the POWER setting).
- 2** Rotate **JOG KEY** to select a menu item.

Setting the MENU Items (EX. VCR Mode menu)

A Press **JOG KEY** to set your selection.

B Rotate **JOG KEY** to select a menu item.



C Press **JOG KEY** to set your selection.
• The "▶" mark indicates selection.

D Press **MENU** to exit the menu.

CAMERA Main menu

- 1 : CAMERA SETUP**
To select PROG. AE, PROGRESSIVE, D. ZOOM, or CINEMA.
- 2 : DIGITAL EFFECT**
To select EFFECT.
- 3 : RECORDING SETUP**
To select REC SPEED, AUDIO REC, SCENEINDEX, WIND CUT, or ZOOM MIC.
- 4 : DISPLAY SETUP**
To select DATE/TIME, C. DISPLAY, C. RESET, or DISPLAY.
- 5 : LCD/EVF SETUP**
To select LCD BRIGHTNESS, LCD COLOR, or EVF BRIGHTNESS.
- 6 : OTHER FUNCTIONS**
To select REMOTE, BEEP SOUND, SHTR EFFECT, CLOCK SET, SELF REC, or DEMO MODE.
- 7 : PHOTO TITLE**
To select TITLE or MODE.

VCR Main menu

- 1 : PLAYBACK FUNCTIONS**
To select BLANK SEARCH, SEARCH, 12 bit AUDIO, or MULTI SPEED.
- 2 : DIGITAL EFFECT**
To select EFFECT1, EFFECT2, or D. ZOOM.
- 3 : RECORDING SETUP**
To select REC SPEED or AUDIO DUB.
- 4 : DISPLAY SETUP**
To select DATE/TIME, C. DISPLAY, C. RESET, or DISPLAY.
- 5 : LCD/EVF SETUP**
To select LCD BRIGHTNESS, LCD COLOR, or EVF BRIGHTNESS.
- 6 : OTHER FUNCTIONS**
To select REMOTE or CLOCK SET.

Simple Recording

Remove the lens cap and clip it to the hand strap.

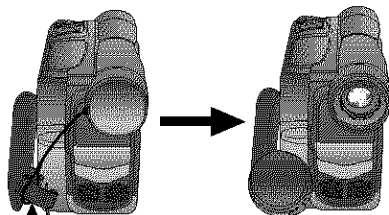

Clip here

EVF

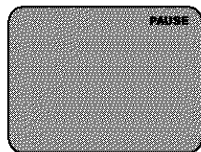

REC/PAUSE mode

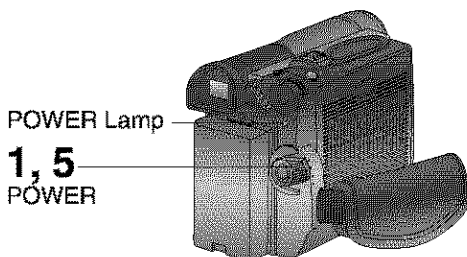

POWER Lamp

1, 5
POWER

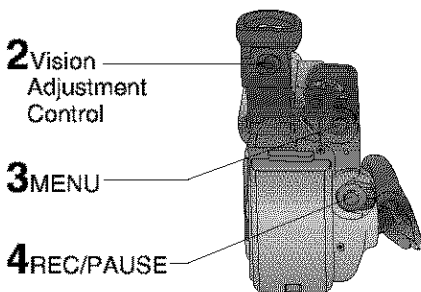

2 Vision
Adjustment
Control

3 MENU

4 REC/PAUSE

WARNING:

- Do not leave the Palmcorder with the EVF aimed directly at the sun as this may cause damage to the internal parts of the EVF.
- Do not lift, or carry, the Palmcorder by the EVF or the LCD Monitor.
- Do not pull hard on the EVF Eye Cup.

Before you begin

- Connect the Palmcorder to a power source. (pp. 15, 16)
- Insert a cassette with the record tab closed. (p. 7)

1

Set **POWER** to **CAMERA**.

- The **POWER** Lamp lights red.
- Be sure **POWER** is fully turned to the **CAMERA** position.

2

With the **Viewfinder Eye Cup** held up against your eye, adjust the **Vision Adjustment Control** to your eyesight.

- Adjust the **EVF Brightness** of the Viewfinder if necessary. Please refer to "To adjust the LCD/EVF BRIGHTNESS or COLOR" on page 20.

3

Set to **REC SPEED "SP"** or **"LP"** in the **RECORDING SETUP** menu screen. (Menu OSD: p. 108)

4

Press **REC/PAUSE** to start recording. "REC" is displayed on the screen. Press **REC/PAUSE** again to pause recording.

5

Set **POWER** to **OFF** when finished.

- To remove the cassette, slide **TAPE EJECT**.

- When the Palmcorder is aimed at excessively bright objects, or bright lights, a vertical bar may appear in the picture. This is a normal characteristic of the CCD pick-up device. Try to avoid this whenever possible.

To conserve power

After 5 minutes, the Record/Pause mode will automatically change to Standby mode.

To resume recording, set **POWER** to **OFF** and then **ON** again.

Using the LCD Monitor

The LCD (Liquid Crystal Display) monitor can be used while recording.

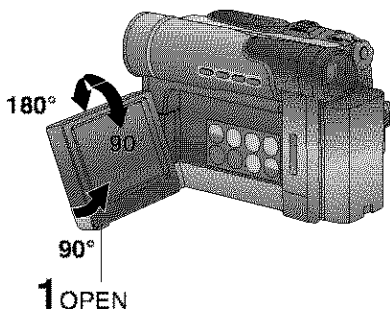

1 Use **OPEN** tab on underside of the LCD monitor to unlock.

2 Swing the LCD monitor fully open and adjust the viewing angle.

- The LCD monitor will automatically turn on.
- When the LCD monitor is completely closed, it will shut off automatically to save power.
- Adjust the LCD Brightness and/or color of the LCD monitor if necessary. Please refer to "To adjust the LCD/EVF BRIGHTNESS or COLOR" below.

3 Start recording.

Note

- Using the LCD monitor will reduce battery operating time.
- Close the LCD monitor completely when not in use.

To adjust the LCD/EVF BRIGHTNESS or COLOR

2, 3, 4
JOG KEY

1, 5
MENU

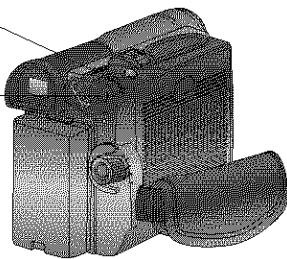

EVF/LCD



1 Press **MENU** to display the main menu screen.

2 Rotate **JOG KEY** to select **LCD/EVF SETUP** from the main menu screen. (Menu OSD: pp. 109, 111)

3 Press **JOG KEY** to display the LCD/EVF SETUP screen.

4 Press **JOG KEY** to select LCD BRIGHTNESS, LCD COLOR, or EVF BRIGHTNESS, then rotate **JOG KEY** to adjust.

5 Press **MENU** twice to exit this mode.

Digital PhotoShot™ Mode

Use this feature to record a seven second (approx.) still image on the tape from the current camera picture. Audio is also recorded for on-the-spot narration. Or, you can add narration later with the Audio Dubbing feature to make an interesting slide show, etc. (p. 45)

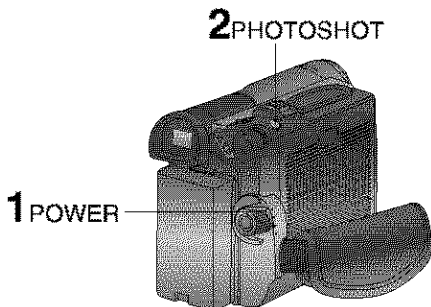

- 1 Set **POWER** to **CAMERA**.
- 2 Press **PHOTOSHOT** in Record/Pause mode. "PHOTO" will appear in the EVF or the LCD monitor.

EVF/LCD



Note

- If **SHTR EFFECT** on the **OTHER FUNCTIONS** menu screen is set to **ON**, a sound effect similar to the shutter of a film camera will be heard when **PHOTOSHOT** is pressed.
- When **PHOTOSHOT** is pressed, the playback image takes approx. 7 seconds to process. After that, the Camera mode screen will be displayed.

Progressive PhotoShot™ Mode

With the progressive PhotoShot Function, you can record still pictures with higher resolution than with the normal PhotoShot Function.

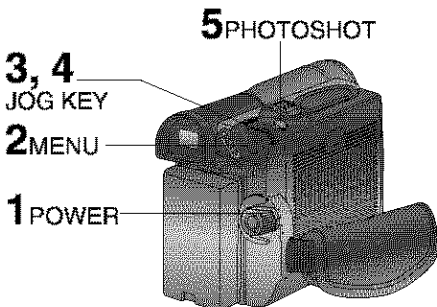

- 1 Set **POWER** to **CAMERA**.
- 2 Press **MENU** to display the **CAMERA FUNCTIONS** menu screen.
- 3 Rotate **JOG KEY** to select **CAMERA SETUP**, and press **JOG KEY** to display the **CAMERA SETUP** menu screen.
- 4 Rotate **JOG KEY** to select **PROGRESSIVE**, and press **JOG KEY** to select **ON**.
 - Press **MENU** to exit.
 - "P" will appear in the EVF or the LCD monitor.
- 5 Press **PHOTOSHOT** in Record/Pause mode.

EVF/LCD



Note

- This function may not work with **D.E.I.S.**, **D. ZOOM** and **D.FUNCTION** functions.

Zoom

You can gradually zoom in for close ups or zoom out for wide angle shots.

2 POWER ZOOM

1 POWER

3 REC/PAUSE

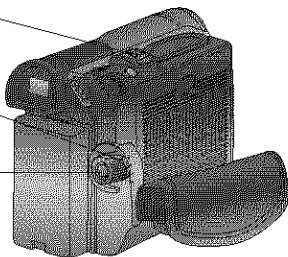

1 Set **POWER** to **CAMERA**.

2 **Zoom slowly:**
by lightly pressing the "T" (Telephoto) or the "W" (Wide Angle) side of the **POWER ZOOM**.

Zoom quickly:
by applying more pressure.

3 Start recording.

Note

- The zooming speed ranges from a slow 17 seconds to a fast 1.8 seconds according to the amount of pressure applied to the **POWER ZOOM**.

Zoom Microphone Function

Along with the zooming operation, the microphone's directional angle and sensitivity are varied for recording sounds.

3, 4, 5 JOG KEY

2 MENU

1 POWER

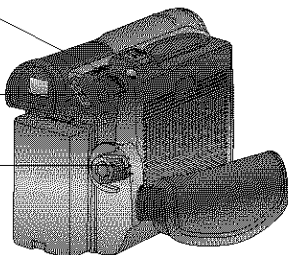

1 Set **POWER** to **CAMERA**.

2 Press **MENU** to display the **CAMERA FUNCTIONS** menu screen.

3 Rotate **JOG KEY** to select **RECORDING SETUP**, then press **JOG KEY** to display the **RECORDING SETUP** menu screen.

4 Rotate **JOG KEY** to select **ZOOM MIC** in the **RECORDING SETUP** menu. (Menu OSD: p. 108)

5 Press **JOG KEY** to select **ON**.
• Press **MENU** to exit.
• "Z.MIC" will appear on the screen.

Note

- The Zoom Microphone Function may not work effectively if the surrounding noise is too loud.

Recording Check

To playback the final few seconds of the last recorded scene in the REC/PAUSE mode.

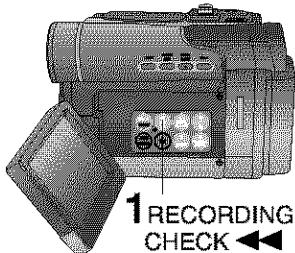

1 RECORDING CHECK

Recording Still Pictures

You can record still pictures of any desired duration together with sound.

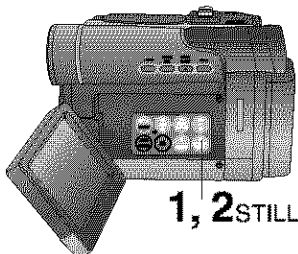

1, 2 STILL

Self Recording

Rotate the LCD monitor 180 degrees so it faces the same direction as the lens to record yourself.

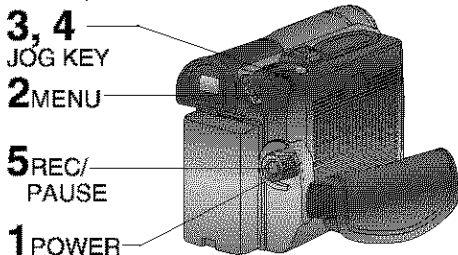

3, 4
JOG KEY

2 MENU

5 REC/
PAUSE

1 POWER

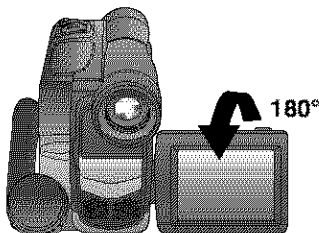

180°

1 Press **RECORDING CHECK** briefly in the REC/PAUSE mode.

The [CHK] indication appears. After checking, the Palmcorder returns to the REC/PAUSE mode.

- For Recording Check, the Palmcorder must be in the same mode (SP or LP) as was used for recording, otherwise the playback picture is distorted.

1 While in RECORD mode, press **STILL** to capture a still picture. The captured still picture will be recorded together with sound.

2 Press **STILL** once again to release the still picture. The camera will resume recording real-time pictures.

1 Set **POWER** to **CAMERA**.

2 Press **MENU** to display the CAMERA FUNCTIONS menu screen.

3 Rotate **JOG KEY** to select **OTHER FUNCTIONS**, then press **JOG KEY** to display the OTHER FUNCTIONS menu screen.

4 Rotate **JOG KEY** to select **SELF REC**, and then press **JOG KEY** to select **MIRROR**. (Menu OSD: p. 109)

- Press **MENU** to exit.
- The picture in the LCD monitor will appear reversed.

5 Start recording.

Special Effect Features

CINEMA Mode

You can record a picture compatible with a wide-screen TV equipped with S-Video picture terminal and Zoom/Wide features.

3, 4
JOG KEY

1 POWER

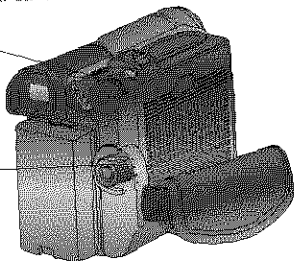

2 MENU

5 REC/PAUSE

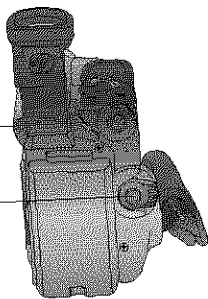

Backlight

Use when recording a subject that is darker than the surrounding scene, in a shadowed area, or when the light source is behind your subject.

1 POWER

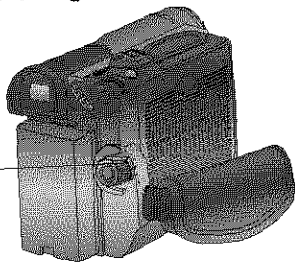

2, 3 BACK LIGHT

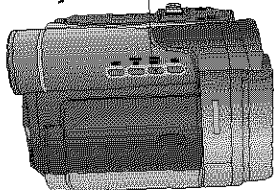

1 Set POWER to CAMERA.

2 Press MENU to display the CAMERA FUNCTIONS menu screen.

3 Rotate JOG KEY to select **CAMERA SETUP**, then press JOG KEY to display the CAMERA SETUP menu screen.

4 Rotate JOG KEY to select **CINEMA**, and then press JOG KEY to select ON.

- A black strip will appear at the top and bottom of the picture.
- Press MENU to exit.
- "CINEMA" will appear on the screen.

5 Start recording.

EVF/LCD



1 Set POWER to CAMERA.

2 Press BACK LIGHT to activate the Backlight feature.

- The Indicator "O" will appear in the EVF or LCD monitor.

3 Press BACK LIGHT again to cancel the Backlight feature.

EVF/LCD

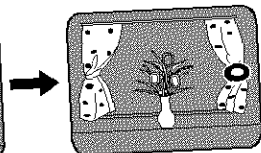
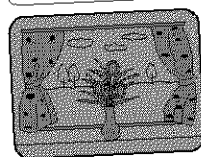

Note

- The Indicator "O" will not appear in the EVF or LCD monitor when OFF is selected in the DISPLAY menu.

Program AE

The Auto Exposure feature can be used to make quality recordings in a variety of scene situations.

4, 5
JOG KEY

3 MENU

1 POWER

2 AUTO/
MANUAL

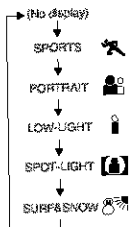
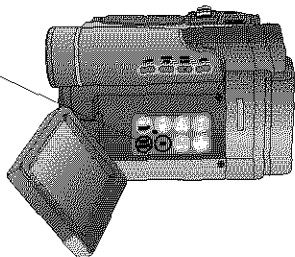
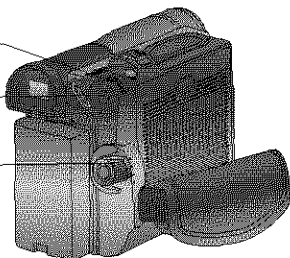

Note

SPORTS mode

- The recorded images will not be so blurred when they are viewed later using slow or still picture playback.
- When playing back a sports mode recording, the movement may appear slightly jerky.
- Do not use this mode when recording under fluorescent, mercury, or sodium lighting. These types of lights will affect the color and brightness of the images.
- A vertical band of light might appear when recording objects that are brightly illuminated or highly reflective.
- If the amount of light is insufficient, the SPORTS "⚡" indicator will flash in the EVF or the LCD monitor.
- The image may flicker if this mode is used indoors.

- 1 Set POWER to CAMERA.
- 2 Press AUTO/MANUAL so that the "MNL" indication appears in the EVF or the LCD monitor.
- 3 Press MENU to display the CAMERA FUNCTIONS menu screen.
- 4 Rotate JOG KEY to select **CAMERA SETUP**, and then press JOG KEY to display the CAMERA SETUP menu screen.
- 5 Rotate JOG KEY to select **PROG AE**, then press JOG KEY repeatedly to select one of the five modes shown below.
 - Press MENU to exit.
- 6 Repeat steps 2-5 to select OFF to cancel this feature.

Mode	Indication
	For recording fast action scenes.
	For recording only subjects in the foreground, while ignoring subjects in the background.
	For recording in extreme low light conditions.
	Recording in situations where subjects are under a spotlight(s).
	For recording in locations with a high degree of "Dazzle," such as snow slopes and the seashore.

PORTRAIT mode

- The image may flicker if this mode is used indoors.

LOW-LIGHT mode

- Scenes recorded in extremely low light levels may turn out dark.

SPOT-LIGHT mode

- If the recorded subject is extremely bright, the picture may appear whitish.

SURF&SNOW mode

- If the recorded subject is extremely bright, the picture may appear whitish.
- It is not possible to select the SPORTS mode or PORTRAIT mode or Low-Light mode together with the GAIN UP mode and MAGIC PIX mode.

Special Effect Features

Audio/Video Fade In/Out

You can make smoother scene transitions for a more professional look.

1, 3, A FADE

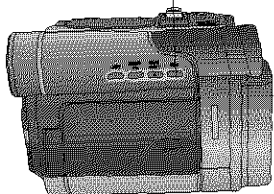

2, B REC/
PAUSE

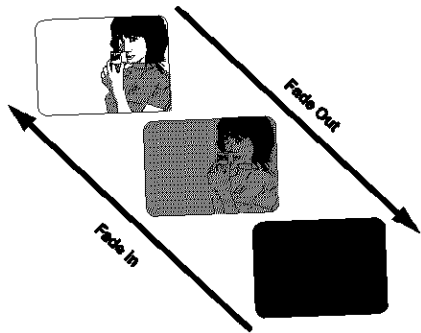
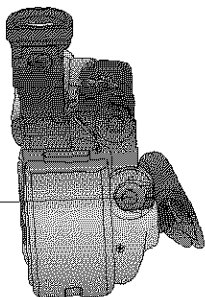

Fade In

Starting the first scene with "fade in" is very effective.

- 1** In REC/PAUSE mode, hold down FADE until the picture fades out.
- 2** Press REC/PAUSE to start recording.
- 3** Release FADE and the picture will gradually fade in.

Fade Out

Use to create a soft ending or (together with fade in) for a soft transition from one scene to the next.

- A** During recording, hold down FADE until the picture fades out.
- B** Press REC/PAUSE to pause the recording.

Photo Title

You can use PhotoShot images stored on a Memory Card to record a WIPE or MIX effect on a cassette.

Note

When Photo Title is set to ON, the selected image and Title will appear before each recording is made.

WIPE : The Photo title is replaced with the current scene in a wiping motion.



MIX : The photo title is replaced with the current scene in a gradual mixing effect.



2, 3, 4
JOG KEY

1 POWER

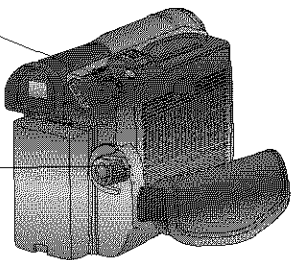

2 MENU

5 REC/
PAUSE

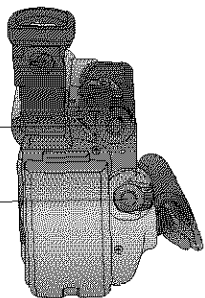

Before you begin

- Connect the Palmcorder to a power source. (pp. 15, 16)
- Set POWER to OFF before inserting a recorded Memory Card. (pp. 49, 50)

- 1** Set POWER to CAMERA.
- 2** Press MENU to display the CAMERA FUNCTIONS menu screen. Then rotate and press JOG KEY to select **PHOTO TITLE**.
- 3** Rotate and press JOG KEY to select and set **MODE** and then **TITLE**.
1st : Select and set MODE (WIPE or MIX).
2nd : Select and set TITLE to "SET".

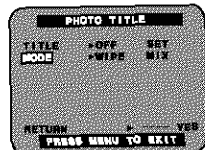

- "PLEASE WAIT" appears on-screen.
- The Multi image screen is displayed.

- 4** Rotate and press JOG KEY to select and set an image.
• "PLEASE WAIT" is displayed while image is processed. Then, "PHOTO TITLE SET" is displayed for approx. 3 seconds, and the screen goes back to the Camera mode screen.
• After Photo Title is performed, Digital Function turns off.
- 5** Press REC/PAUSE to start recording with Photo Title.
• WIPE or MIX screen is displayed at the beginning of the recording. Then the Photo Title setting will be cleared automatically.

White Balance

Auto White Balance ("AWB") automatically maintains optimum color balance in most lighting conditions. However, when using Digital Functions, etc., you may get better results by using the manual adjustment.

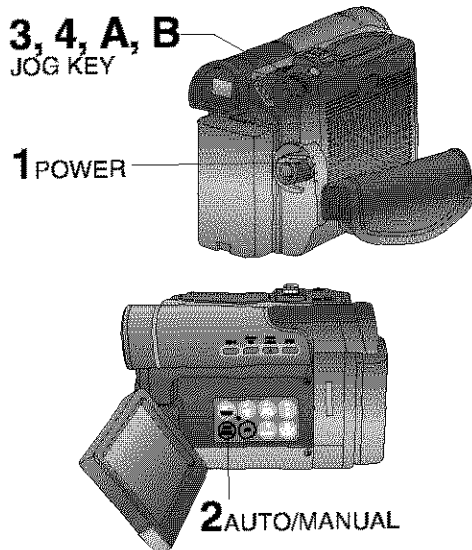

- 1** Set **POWER** to **CAMERA**.
- 2** Press **AUTO/MANUAL** so that the "MNL" indication appears in the EVF or the LCD monitor.
- 3** Press **JOG KEY** repeatedly until "AWB" appears in the EVF or LCD monitor.
- 4** Rotate **JOG KEY** to select other modes. (See mode chart at left.)
 - Press **AUTO/MANUAL** to cancel the setting.

* For manual White Balance adjustment:

- A.** Rotate **JOG KEY** to select "☐".
 - B.** Point the Palmcorder at a white object (full-screen) and hold **JOG KEY** down until "☐" indication stops flashing.
 - If "☐" indication flashes when the Palmcorder is turned on, the previous manual White Balance setting is in effect.
- In the following cases, the "☐" indication flashes:**
- The flashing indicates that the previously adjusted White Balance setting is still kept. This setting will be kept until White Balance is adjusted again.
 - Correct White Balance may not be attainable manually in poor lighting conditions.

Mode	Description
AWB	Automatically maintains optimum color balance in most lighting conditions.
☉	When the source illumination is a halogen lamp.
☼	When shooting outdoors on a sunny day.
* ☐	<p>The White Balance setting that was previously set manually.</p> <p>Note</p> <ul style="list-style-type: none"> • When ZOOM is set to 10X or higher, White Balance cannot be adjusted.

Note

- **DISPLAY** (Menu OSD: p. 109) must be set to **ALL** for **MF**, **AE**, **W.BALANCE**, **HIGH SPEED SHUTTER**, or **IRIS** to be displayed on the LCD or EVF.
- While "GAIN UP" or "MAGICPIX" is displayed on the LCD or EVF, Manual White Balance is inoperable.

Auto Focus

The Palmcorder automatically adjusts the focus over the entire zoom range.

Manual Focus

Use Manual Focus (MF) when recording ...

- a subject through glass.
- a scene where the subject is far from the Palmcorder and there are objects in the foreground.
- a subject with distinct horizontal stripes.
- a subject not centered in the Viewfinder.
- subjects with shiny surfaces.
- an obliquely angled subject.
- a bright, flat subject such as a white wall.
- in low light situations.
- a scene with fast motions, like a golf swing.

Re-focusing may be required

- when your Palmcorder is aimed at a new scene.

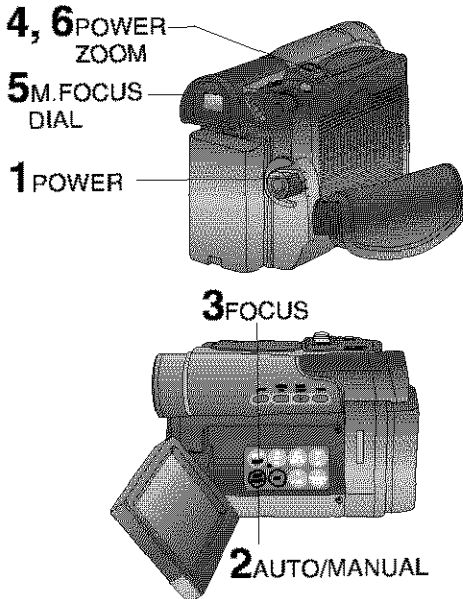

- 1** Set **POWER** to **CAMERA**.
- 2** Press **AUTO/MANUAL** so that the "MNL" indication appears in the EVF or the LCD monitor.
- 3** Press **FOCUS** so that the "MF" (Manual Focus) indication appears in the EVF or the LCD monitor.
- 4** Press and hold **POWER ZOOM**, "**T**" side (**Telephoto**), until the lens is at maximum zoom in.
- 5** Turn **M.FOCUS DIAL** until the picture is in focus.
 - It may be necessary to back away from the subject to focus the image properly.
- 6** Press **POWER ZOOM** to "**W**" or "**T**" as desired.
 - The subject will remain in focus over the entire zooming range.
 - It may be necessary to back away from the subject to focus the image properly.

Macro Focus (for close-ups)

Press the "**W**" side of **POWER ZOOM** to the maximum wide angle position.

Auto Focus will function with the subject as close as 25 mm (1 inch) in front of the lens.

High Speed Shutter

To record high speed motion (e.g. tennis stroke) with improved STILL or SLOW MOTION playback when watching the tape on this Palmcorder.

Manual Selection

3, 4

JOG KEY

1 POWER

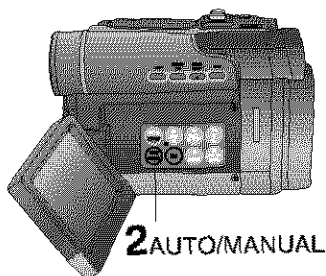
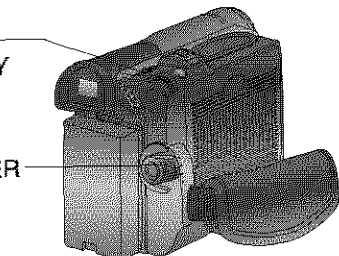

2 AUTO/MANUAL

1

Set POWER to CAMERA.

2

Press AUTO/MANUAL so that the "MNL" indication appears in the EVF or the LCD monitor.

3

Press JOG KEY repeatedly to display the shutter speed.

4

Rotate JOG KEY to choose one of the following shutter speeds.

- Press AUTO/MANUAL to cancel the setting.

Note

- For proper color reproduction, it is recommended that you use this feature outdoors. For indoor High Speed Shutter recording, additional halogen or tungsten light should be provided. Fluorescent light will degrade the picture quality.
- This feature requires ample light. More light is required for the fastest shutter speeds.
- The Auto Focus system may not operate properly in insufficient light when using the High Speed Shutter.
- When PROG.AE is ON, you cannot manually select the shutter speed.
- When MagicPix or GAIN UP is ON, H.S.S. cannot manually select the shutter speed.
- When PROGRESSIVE is set to ON, the shutter speed cannot be adjusted to 1/750 s or faster.

EVF/LCD

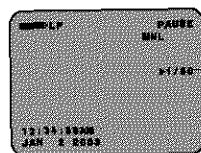

M-CARD Mode

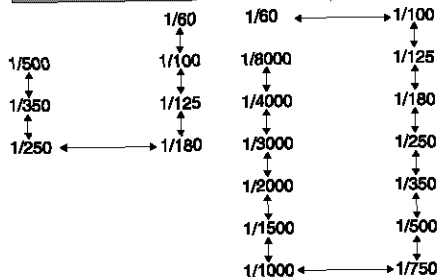

Adjusting the Iris Manually

Normally, the Palmcorder adjusts the exposure automatically. However, when the background is extremely bright, or when the subject is backlit, you can compensate by adjusting the iris manually.

3, 4
JOG KEY

1 POWER

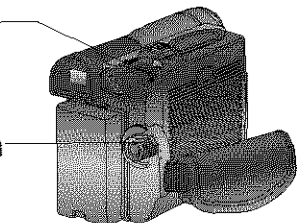

2 AUTO/MANUAL

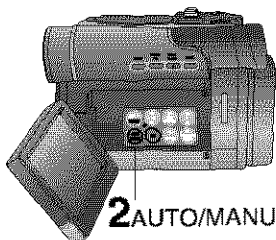

EVF/LCD

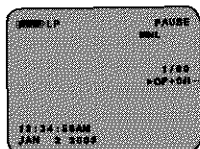

Iris
Setting

WIND CUT

You can reduce sound distortion caused by wind hitting the microphone.

3, 4
JOG KEY

1 POWER

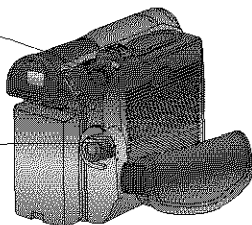

2 MENU

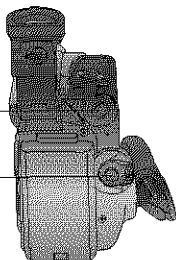

5 REC/PAUSE

1 Set POWER to CAMERA.

2 Press AUTO/MANUAL so that the "MNL" indication appears in the EVF or the LCD monitor.

3 Press JOG KEY repeatedly so that Iris setting indication appears in the EVF or the LCD monitor.

4 Rotate JOG KEY to adjust the iris;

- When a value closer to "CLOSE" is selected, the image becomes darker.
- When a value closer to "OP+18dB" is selected, the image becomes brighter.
- Press AUTO/MANUAL to cancel the setting.

Note

- The value to which +dB is attached indicates a gain value. If this value is too large, the quality of the image deteriorates.
- Depending on ZOOM magnification, the iris value may not be displayed correctly.
- If you are using Program AE mode, you cannot adjust the iris. If the iris is adjusted manually, the above modes will be canceled.

1 Set POWER to CAMERA.

2 Press MENU to display the CAMERA FUNCTIONS menu screen.

3 Rotate JOG KEY to select **RECORDING SETUP**, then press JOG KEY to display the RECORDING SETUP menu screen.

4 Rotate JOG KEY to select **WIND CUT**, and then press JOG KEY to select ON.

- Press MENU to exit.
- "WIND CUT" will appear in the EVF or LCD monitor.

5 Start recording.

Playback using the LCD Monitor

You can also use the LCD monitor to play back your recording.

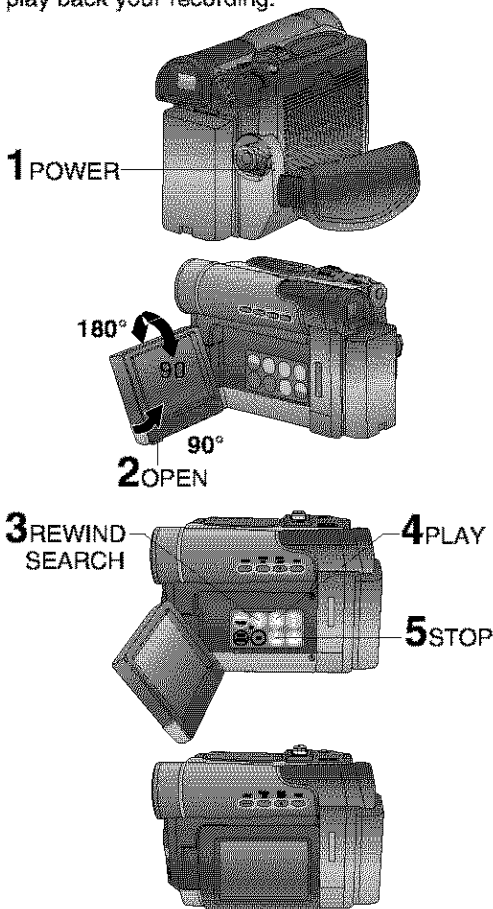

Connecting Earphone (not supplied)

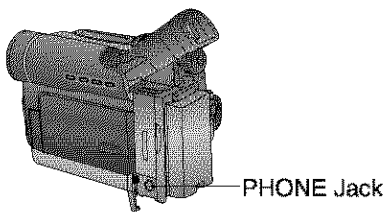

Before you begin

- Connect the Palmcorder to a power source. (pp. 15, 16)
- Insert a recorded cassette.

- 1** Set the **POWER** to **VCR**.
 - The **POWER** lamp lights red.
 - Be sure **POWER** is fully turned to the **VCR** position.
- 2** Use **OPEN** tab on underside of the LCD monitor to unlock and swing open.
- 3** Press **◀** (**REWIND/SEARCH**) to rewind the tape.
- 4** Press **▶** (**PLAY**) to start playback.
- 5** Press **■** (**STOP**) to stop playback.
 - When the tape reaches its beginning during rewind or rewind search, it will stop automatically.

Note

- When a tape recorded in LP mode on another digital video camera is played back on this unit, the picture may appear mosaic.
- Using the LCD monitor reduces battery operating time.
- You can place the Palmcorder on a table, etc. for viewing. Rotate the LCD Monitor 180° and swing it up against the Palmcorder body as shown.

You can connect earphones (not supplied) to the **PHONE** Jack.

Playback Your Recordings

Repeat Playback

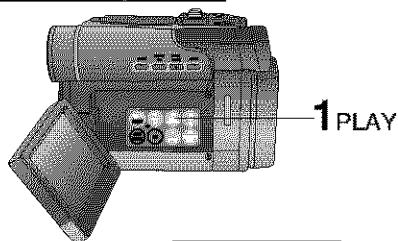

EVF/LCD

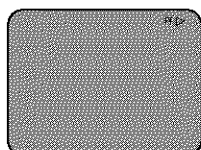

- 1 Press **PLAY** for more than **5 seconds** in STOP mode.
 - The Palmcorder will go into Repeat Playback mode when the tape reaches its end.
 - The letter "R ▷" will appear in the EVF and LCD monitor.

- 2 Turn the Palmcorder **OFF** to exit the Repeat Playback mode.

Adjusting the Volume

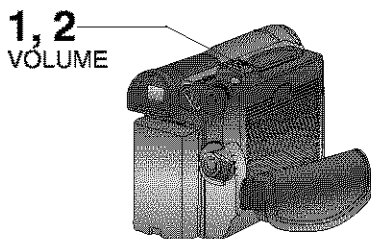

EVF/LCD

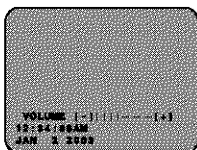

- 1 Slide **VOLUME** to adjust the volume of the built-in speaker in PLAY mode.
 - The volume setting screen appears.
- 2 Press "**T**" to increase the volume.
Press "**W**" to decrease the volume.

VCR

Blank Search

You can go directly to a blank portion of tape and start recording exactly where you left off.

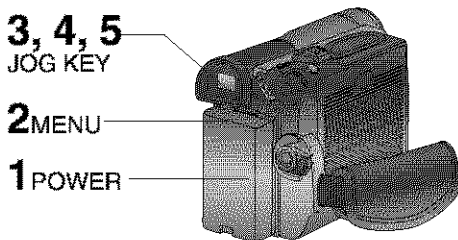

EVF/LCD

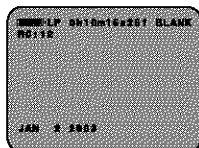

- 1 Set **POWER** to VCR.
- 2 Press **MENU** to display the VCR **FUNCTIONS** menu screen.
- 3 Rotate **JOG KEY** to select **PLAYBACK FUNCTIONS**, then press **JOG KEY** to display the **PLAYBACK FUNCTIONS** menu screen.
- 4 Rotate **JOG KEY** to select **BLANK SEARCH** in the **PLAYBACK FUNCTIONS** menu.
(Menu OSD: p. 110)
- 5 Press **JOG KEY** to select **ON**.
 - "BLANK" will appear on the screen.

Special Effect Features

Note

- Sound is muted during all special effects.

Rapid Visual Search

A, B REWIND/
SEARCH

B PLAY

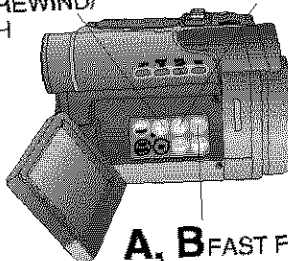

A, B FAST FORWARD/
SEARCH

EVF/LCD

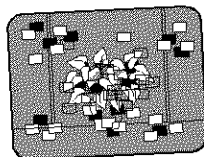

A During playback, hold down **▶▶** (FAST FORWARD/SEARCH) or **◀◀** (REWIND/SEARCH).

The search will continue for as long as the button is held down.

OR

B Press **▶▶** (FAST FORWARD/SEARCH) or **◀◀** (REWIND/SEARCH) once for a continuous rapid visual search.

Press **▶** (PLAY) to release.

Note

- When executing a rapid visual search, the picture may become bluish for an instant or mosaic. This is normal during this mode.

STILL Picture

2 PLAY

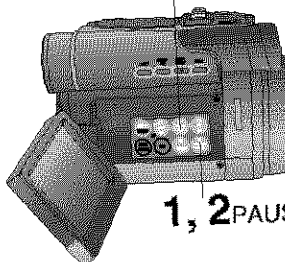

1, 2 PAUSE

1 Press **||** (PAUSE) during playback.

2 Press **▶** (PLAY) or **||** (PAUSE) to release.

Note

- To protect the tape and video heads, your Palmcorder's operating modes will revert as follows:
STILL \rightarrow STOP (after 3 minutes.)

Fast Forward/Rewind Check

Monitor normal picture playback during fast forward or rewind.

B REWIND/
SEARCH

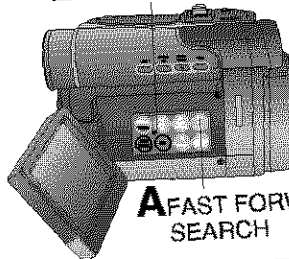

A FAST FORWARD/
SEARCH

A Hold down **▶▶** (FAST FORWARD/SEARCH) during fast forward.

B Hold down **◀◀** (REWIND/SEARCH) during rewind.

- The picture will appear for as long as the button is held down.

Note

- Sound is muted during all special effects.

Slow Motion Playback (Optional Remote Control Only)

Optional

2 **PLAY**

1 **▶ SLOW/
F.ADV**

1 **◀ SLOW/
F.ADV**

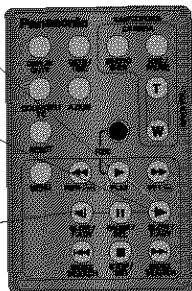

1

Forward Slow:
Press **▶ SLOW/F.ADV** during play.

Reverse Slow:
Press **◀ SLOW/F.ADV** during play.

2

Press **PLAY** to release. (During reverse slow motion playback, time code indication may not change regularly.)

Note

- Palmcorder will automatically STOP when in slow motion for more than 10 minutes.
- During slow motion playback, picture may move up and down. This is normal.
- When you start or stop slow motion playback, the picture may become bluish for an instant.

VCR

Variable Speed Search

2, 3
JOG KEY

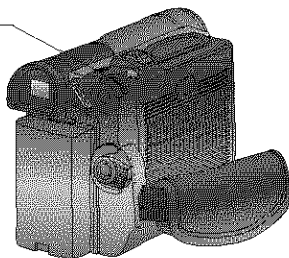

1 **PLAY**

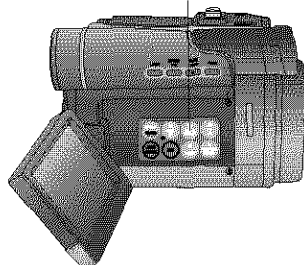

1

Press **▶ (PLAY)** to start playback.

2

Press **JOG KEY** for about 1 second.

3

Rotate **JOG KEY** to adjust the playback speed.

- Rotate **JOG KEY** clockwise for forward playback.

- Rotate **JOG KEY** counterclockwise for reverse playback.

To return to normal playback:

Press **▶ (PLAY)**. Playback will continue at normal speed.

Note

- The Variable Speed Search function offers a choice of six playback speeds (1/5X (LP mode: 1/3X), 1X, 2X, 5X, 10X, 20X) both in forward and reverse directions.
- The review playback at the 1X speed is playback in reverse direction.
- During the Variable Speed Search (except 1X speed in forward direction), mosaic-like patterns will appear in the picture.
- During the Variable Speed Search, sound is muted.
- The Variable Speed Search feature is not available when the Repeat Playback is active.

Special Effect Features

Note

- Sound is muted during all special effects.

Frame by Frame Advance

When using Optional Remote Control

Optional

3 **PLAY**

1 **PAUSE**

2 **◀| SLOW/
F.ADV**

2 **|▶ SLOW/
F.ADV**

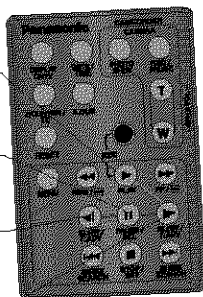

1 Press **PAUSE** during playback.

2 Press **|▶ SLOW/F.ADV** to do a frame by frame advance.

Press **◀| SLOW/F.ADV** to do a frame by frame reverse.

3 Press **PLAY** to release.

Note

- If you hold down **SLOW/F.ADV**, you can see a continuous series of still images at a slower speed than normal slow mode.
- During frame by frame advance, a few frames may move automatically, and the picture may become bluish for an instant.

When using Palmcorder

1 **JOG KEY**

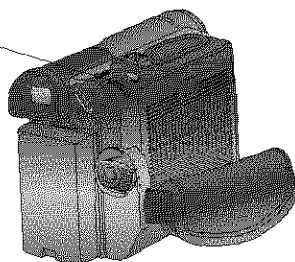

1 During Still mode, rotate **JOG KEY** to advance or reverse the picture one frame at a time.

Note

- Sound is muted during all special effects.

Index Search (Photo/Scene) (Optional Remote Control Only)

Search for a particular scene by using the electronic index marks placed at the beginning of each recording.

- 2, 3
JOG KEY
- 1 MENU

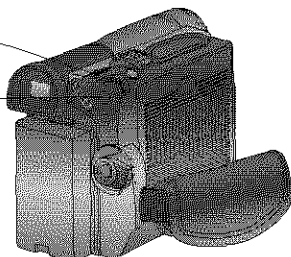

Optional

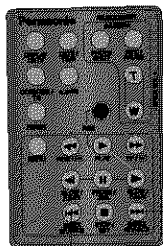

- B** INDEX SEARCH
(rewind)

- B** INDEX SEARCH
(fast forward)

Top Scan

If you hold down INDEX SEARCH for more than 2 seconds, the Palmcorder will scan for scenes (or PhotoShots) and playback the first few seconds of each.

To cancel this function, press PLAY or STOP.

Note

- Search will not work if there is a succession of PhotoShots.

- 1 Press **MENU** to display the VCR FUNCTIONS menu screen.
- 2 Rotate **JOG KEY** to select **PLAYBACK FUNCTIONS**, then press **JOG KEY** to display the PLAYBACK FUNCTIONS menu screen.
- 3 Rotate **JOG KEY** to select **SEARCH**, and then press **JOG KEY** to select PHOTO or SCENE. (Menu OSD: p. 110)
 - Press MENU to exit.

A Place the Palmcorder in the VCR STOP mode.

B Press **INDEX SEARCH** fast forward or rewind for the number of recordings (indexes) forward or back you want to view. The Palmcorder will advance or rewind to the desired recording and automatically start playback.

- The number of times you pressed the button is displayed in the EVF and the LCD monitor if you set SEARCH on the VCR menu to SCENE. (Menu OSD: p. 110) (e.g., if you press the button three times, "S3" will appear.)
- If the interval between scenes is less than 1 minute, index search may not operate properly.
- Response time from pressing the button and the change in the scene number is quite slow. Do not press INDEX SEARCH rapidly and continuously.
- During Reverse Index Search mode, playback will not begin when a tape rewinds all the way to the beginning.

Note

- The picture quality will deteriorate slightly.
- The tape remaining indicator will not appear while the PHOTOSHOT feature is used.
- In the Photo/Scene Index Search mode, the shutter sound effect may not be able to be heard even when SHTR EFFECT is set to ON.
- Photo Index Search may fail to detect a recorded PhotoShot image if the image is 3 seconds or less.

Special Effect Features

Strobe Multi Mode

In Strobe Multi Mode, you can select the rate at which a succession of still screens are captured from the playback picture.

3, 4, 5
JOG KEY

2 MENU

1 POWER

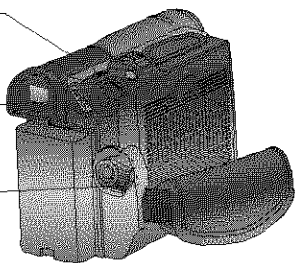

6 MULTI

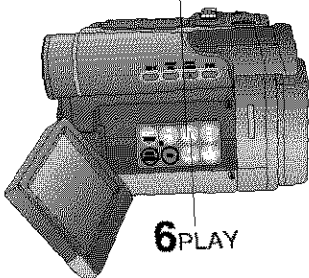

6 PLAY

1 Set **POWER** to **VCR**.

2 Press **MENU** to display the **VCR FUNCTIONS** menu screen.

3 Rotate **JOG KEY** to select **PLAYBACK FUNCTIONS**, then press **JOG KEY** to display the **PLAYBACK FUNCTIONS** menu screen.

4 Rotate **JOG KEY** to select **MULTI SPEED** in the **PLAYBACK FUNCTIONS** menu screen.
(Menu OSD: p. 110)

5 Press **JOG KEY** repeatedly to set desired speed.

Strobe Speeds

Strobe Speeds: 9 screen capture time	
FAST	Every 0.3 seconds
NORMAL	Every 0.6 seconds
SLOW	Every 1.0 seconds

• Press **MENU** to exit.

6 Press **▶ (PLAY)** to start playback.
Press **▶ (MULTI)** at the point you want to start capturing.
• A succession of 9 screens will be captured, and playback will stop.

EVF/LCD

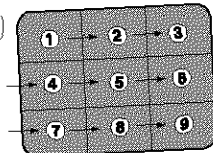

• Press **▶ (PLAY)** to start playback.
Press **■ (STOP)** to stop playback.

Note

- A Multi image Playback screen cannot be output from the DV terminal or USB terminal.
- A Multi screen will have slightly lower image quality.

View Recording/Playback on your TV

[TV with AUDIO/VIDEO IN Jacks]

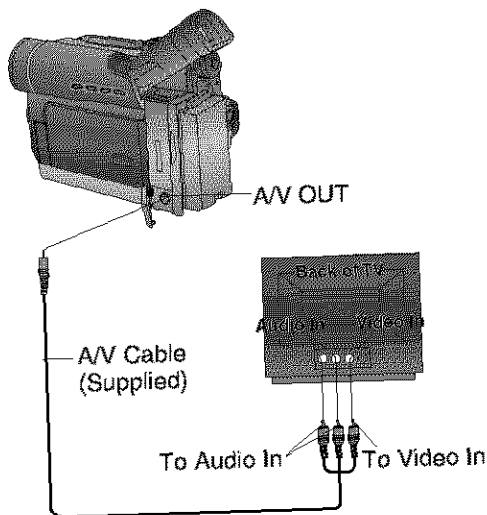

[TV with S-VIDEO IN Jacks]

For best Chrominance and Luminance, use the S-Video connection if available on your TV.

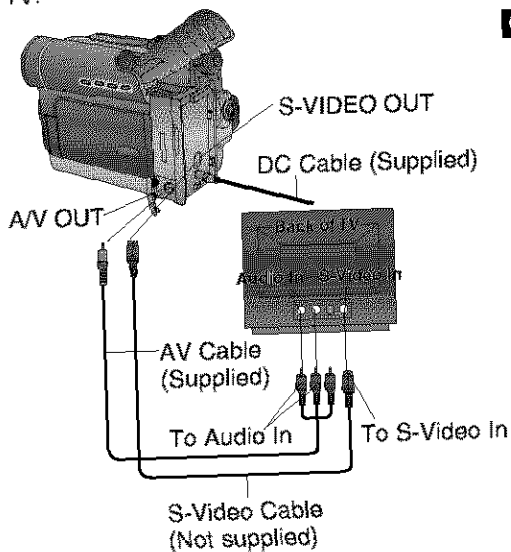

Before you begin

- When using S-VIDEO Connector, insert the DC Cable into the DC IN Terminal. (p. 16)

1 Set **POWER** to **CAMERA** or **VCR**.
To view what the Palmcorder is recording or to playback a tape on your TV.

2 Turn your TV **ON** and set it to **LINE INPUT** or **S-VIDEO**.
Check your TV operating instructions for further information.

3 Start playback or begin a recording.

- Make sure the Palmcorder and TV are turned off while connecting.
- Please connect the A/V Cable securely.

Note

(Optional Remote Control Only)

You can display the various EVF and LCD indications on your TV by pressing **DISPLAY ON TV** on the remote control. Press again to remove the indications.

Optional

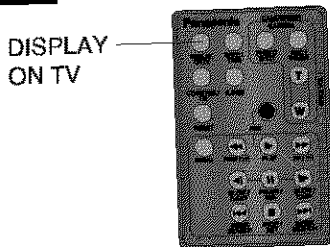

VCR

Digital Zoom

This feature is useful when you want to record close-up shots of subjects located beyond a normal zoom range of 1X to 10X magnification. With the digital zooming feature, you can select a magnification of 25X, or even up to 700X.

Note

- Other Digital Functions are turned off automatically when the EIS and Digital Zoom are selected.

EVF/LCD

Zoom In ("T")



Zoom Out ("W")

5 POWER ZOOM

3, 4 JOG KEY

1 POWER

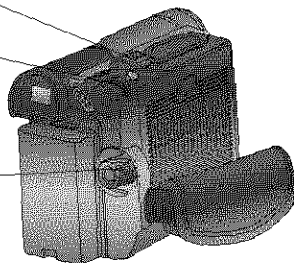

2 MENU

5 REC/PAUSE

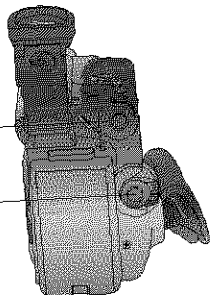

CAMERA mode

- 1 Set **POWER** to **CAMERA**.
- 2 Press **MENU** to display the **CAMERA FUNCTIONS** menu screen.
- 3 Rotate **JOG KEY** to select **CAMERA SETUP**, then press **JOG KEY** to display the **CAMERA SETUP** menu screen.
- 4 Rotate **JOG KEY** to select **D.ZOOM**, then press **JOG KEY** to select 25X or 700X.
 - 25X : from 10X to 25X
 - 700X : from 10X to 700X
 - OFF : Turn off D.ZOOM
 - Press **MENU** to exit.
- 5 Press **REC/PAUSE** to start recording and press **POWER ZOOM** to zoom in or zoom out.
 - The magnification level is always displayed in the EVF or the LCD monitor when **DISPLAY** is set to **ALL** or **PARTIAL**.
(Menu OSD: p 109)
- 6 Repeat steps 2-4 to select **OFF** to cancel this feature.

Note

- The normal optical zoom functions from 1X to 10X.
- As magnification increases, resolution significantly decreases.
- Because the image is enlarged digitally, the picture may become distorted when higher magnification levels are used.
- When the level falls below 10X, the normal zooming function will resume.
- Focus distance becomes 1.2 m (4 feet) if the lens is in full telephoto.

Digital Zoom (Continued)

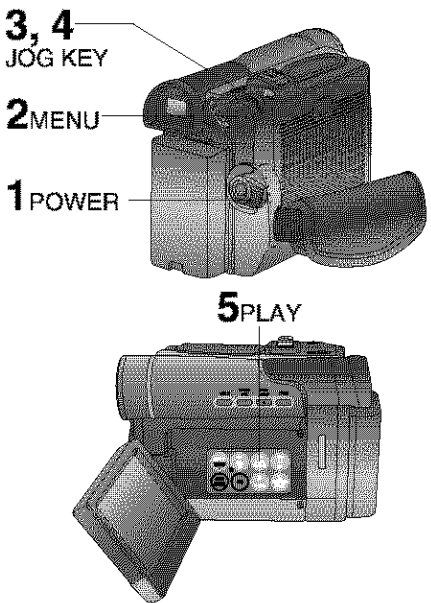

VCR mode

- 1** Set **POWER** to **VCR**.
- 2** Press **MENU** to display the **VCR FUNCTIONS** menu screen.
- 3** Rotate **JOG KEY** to select **DIGITAL EFFECT**, then press **JOG KEY** to display the **DIGITAL EFFECT** menu screen.
- 4** Rotate **JOG KEY** to select **D.ZOOM**, then press **JOG KEY** to select **ON**.
 - Press **MENU** to exit.
- 5** Press **▶ (PLAY)** to start playback.
 - The center portion of the image doubles in size.
- 6** Repeat steps 2-4 to select **OFF** to cancel this feature.

MagicPix™ Images

Color recording of video or still images onto the Mini DV tape in low lighting.

Note

- MagicPix cannot be used with still images on the Memory Card. (See "Card PhotoShot" on page 49.)

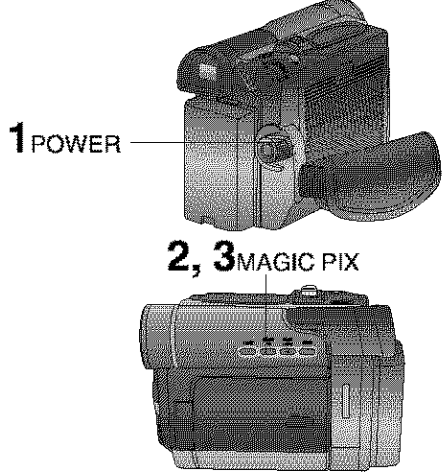

- 1** Set **POWER** to **CAMERA**.
- 2** Press **MAGIC PIX**.
 - "MAGICPIX" will appear on the screen.
- 3** To cancel the Digital Function, press **MAGIC PIX** again.

EVF/LCD

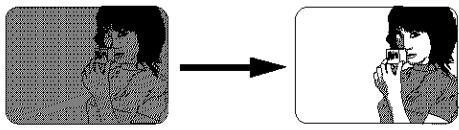

Note

- The image will be brighter than with **GAIN UP**, however motion jitter will be much greater.

Dual Digital Electronic Image Stabilization System (D.E.I.S.)

This feature helps compensate for any unintentional hand or body movement. It can be used in both the Recording and Playback (VCR) modes.

Note

- Other Digital Functions are turned off automatically when the EIS and Digital Zoom are selected.

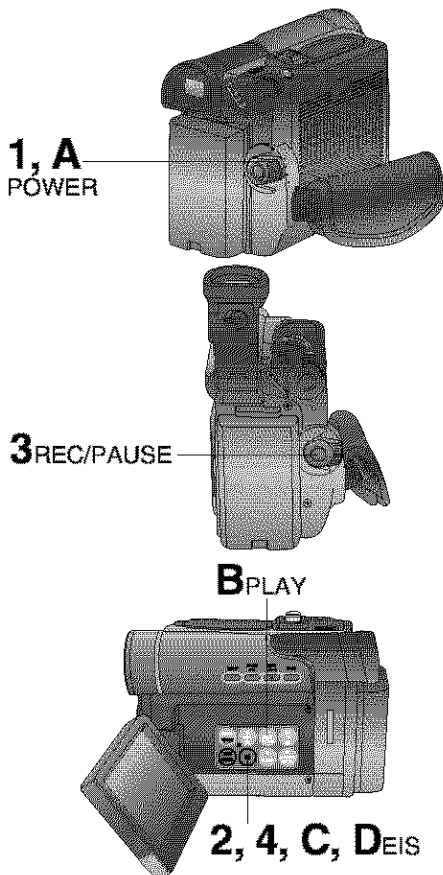
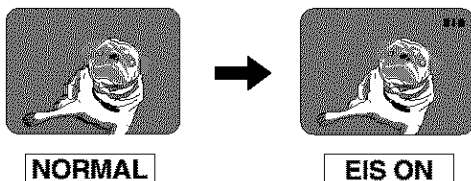

CAMERA mode

- 1 Set **POWER** to **CAMERA**.
- 2 Press **EIS** to stabilize the picture.
 - Picture flicker may be observed when taping under fluorescent lighting conditions.
 - The EIS indicator flashes when the light level is inadequate.
 - Turn D.E.I.S. OFF during recording when using a tripod.
- 3 Press **REC/PAUSE** to start recording.
- 4 Press **EIS** again to cancel.
 - Be sure that D.E.I.S. is turned off when not needed.

D.E.I.S. may not function when...

- Palmcorder movement is too extreme.
- Recording a subject with distinct horizontal or vertical stripes.
- Recording in low light situations.
- Recording a subject under a great amount of fluorescent light.
- Recording a scene with very fast motions.

VCR mode

- A Set **POWER** to **VCR**.
- B Press **▶ (PLAY)** to start playback.
- C Press **EIS** to stabilize the picture.
- D Press **EIS** again to cancel.
 - Be sure that D.E.I.S. is turned off when not needed.

Note

- When using D.E.I.S. in VCR mode, the image size is slightly larger.

Other Digital Functions

Use the following features to add interest and professionalism to your recordings or playback. Select from twelve special effects.

3, 4, 5
JOG KEY

2 MENU

1 POWER

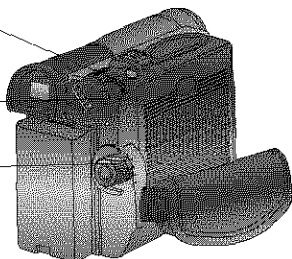

Types of Digital Functions

MIRROR

Symmetrical image from the current camera picture.

STROBE

The recording appears as a sequence of still frames.

MOSAIC

The picture appears in a mosaic pattern.

SLIM

The picture is expanded vertically.

TRAIL

The subject being recorded creates a trail when in motion.

STRETCH

The picture is expanded horizontally.

GAIN UP (Not available during playback)

Picture sensitivity is increased.

- The image will be brighter than normal, however motion jitter will occur.

WIPE (Not available during playback)

Successive scenes are separated in a way which simulates the drawing of a curtain.

MIX (Not available during playback)

The current scene is mixed in with the following scene during scene changes.

P-IN-P (Not available during playback)

PinP (Still image) is displayed on the Main Picture.

SEPIA (Only available during playback)

The picture is played back in sepia, a brownish color, giving it an antique look.

B/W (Black-and-white) (Only available during playback)

The picture is played back in black-and-white.

1 Set **POWER** to **CAMERA** or **VCR**.

2 Press **MENU** to display the menu screen.

3 Rotate **JOG KEY** to select **DIGITAL EFFECT** in the **CAMERA** or **VCR** mode menu screen, then press **JOG KEY** to display the **DIGITAL EFFECT** menu screen.

4 Rotate **JOG KEY** to select **EFFECT** in the **CAMERA** mode menu screen or **EFFECT1/EFFECT2** in the **VCR** mode menu screen, and then press **JOG KEY** repeatedly to select one of the Digital Functions listed on the left.

5 To cancel the Digital Function, press **JOG KEY** repeatedly to select **OFF**.

Note

- The **EIS** and **Digital Zoom** features are turned off automatically when one of the **Digital Functions** listed at left is selected.

To use the WIPE function

- In Camera mode, set the "EFFECT" item in the main menu screen to "WIPE". (Menu OSD: p. 108)
- Press **REC/PAUSE** to start recording.
- Press **REC/PAUSE** to pause the recording. The last scene will be memorized.
- Press **RECORD/PAUSE** to start recording again. The new scene will take the place of the memorized scene.

To use the MIX function

- In Camera mode, set the "EFFECT" item in the main menu screen to "MIX". (Menu OSD: p. 108) Then, perform steps **b-d** above.

The memorized scene and the new scene will appear mixed as the scene changes from one to the other.

Note

- When Photo Title is set, **WIPE/MIX** mode becomes Photo Title. When Photo Title is finished, Digital Function turns **OFF**.

Picture in Picture (PinP)

You can display a PinP (still image) screen on the Main Picture.

Note

- PinP position is fixed at the bottom right of the screen.

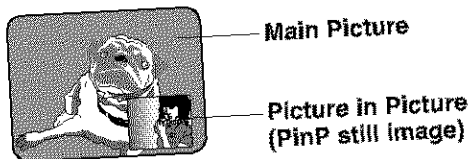

PHOTOSHOT

3, 4
JOG KEY

1 POWER

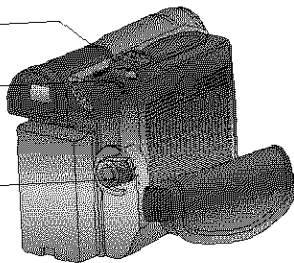

2 MENU

7 REC/
PAUSE

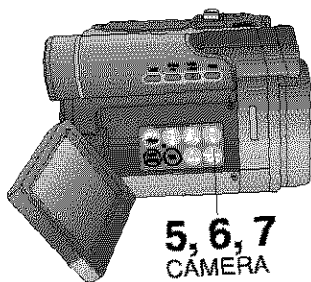
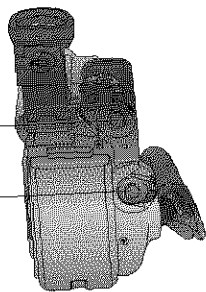

5, 6, 7
CAMERA
STILL

1 Set POWER to CAMERA.

2 Press MENU to display the CAMERA FUNCTIONS menu screen.

3 Rotate JOG KEY repeatedly to select DIGITAL EFFECT, then press JOG KEY to display the DIGITAL EFFECT menu screen.

4 Press JOG KEY to select PINP.
• Press MENU to exit this menu.
• "P-IN-P" will appear in the EVF or the LCD monitor.

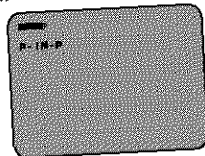

5 Aim at the scene you wish to place as PinP, then press II (CAMERA STILL) to freeze the image.

6 Press II (CAMERA STILL) again to place the frozen image as PinP.

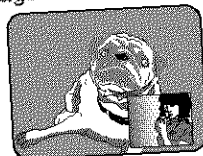

7 Press REC/PAUSE to record a scene with PinP image.

- Press PHOTOSHOT to record a scene with PinP image in PhotoShot mode.

- Press II (CAMERA STILL) again to remove PinP image.

Audio Dubbing using the Built-in Microphone

The original sound can be replaced with new sound using the built-in Palmcorder microphone.

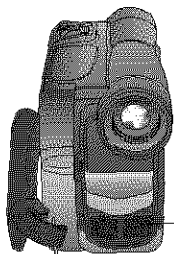

Built-in Microphone

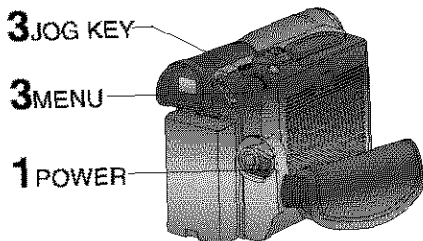

3 JOG KEY

3 MENU

1 POWER

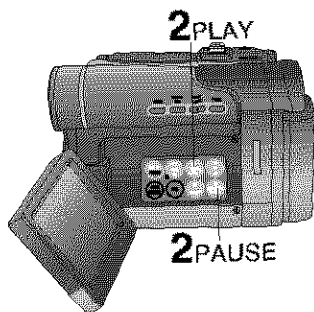

2 PLAY

2 PAUSE

Optional

3 A.DUB

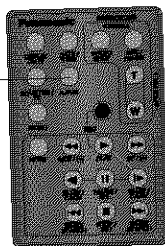

Before you begin

- Turn on the Palmcorder.
- Insert a pre-recorded tape to be dubbed.

12 bit	The original sound is recorded on ST (Stereo) 1, and the new sound will be recorded on ST (Stereo) 2.
16 bit	The original sound is replaced with the new sound.

- Select 12 bit if you do not want the original sound to be completely replaced during an audio dub.
- With tape containing both 12 bit and 16 bit audio, please note that if dubbing is started in a 16 bit portion, the 12 bit audio will also be completely replaced.

1 Set POWER to VCR.

- If you have the optional Remote Control, you can set the Palmcorder to stop automatically at a specific point on the tape. See "Memory-Stop Editing" on page 46.

2 Press ► (PLAY). Then press II (PAUSE) where you want dubbing to begin.

When using the Palmcorder only

3 Press MENU to display the VCR FUNCTIONS menu screen.

Rotate JOG KEY to select **RECORDING SETUP**, then press JOG KEY to display the RECORDING SETUP menu screen.

Rotate JOG KEY to select **AUDIO DUB**, and then press JOG KEY to select ON.

- The Palmcorder will go to Stand By mode, and "A.DUB II" indication appears in the EVF or the LCD monitor. Go to step 4.

When using the Optional Remote Control only

3 Press A.DUB on the Remote Control.

- The Palmcorder will go to Stand By mode, and "A.DUB II" indication appears in the EVF or the LCD monitor. Go to step 4.

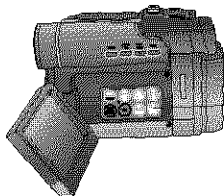

4, 5 PAUSE

To listen to the desired audio sound, set the 12bit AUDIO setting of the VCR mode MENU (Menu OSD: p. 110) as follows:

12bit AUDIO: The following selections are available for 12 bit AUDIO dubbed recordings only (sound recorded in SP mode only).

ST 1	Set this position to listen to the original sound.
ST 2	Set this position to listen to the audio dubbed sound.
MIX	Set this position to listen to both the original sound and the audio dubbed sound.

Note

- When a 16 bit recording is dubbed over, the original audio of the recording will be erased.
- When a 12 bit recording is dubbed over and played back, and MIX is selected as the AUDIO, both the original audio and the dubbed audio are played back.
- If you recorded in LP mode, you cannot use the A.DUB feature.

Memory-Stop Editing

You can set an automatic Dubbing stop point.

Optional

D RESET
A MENU

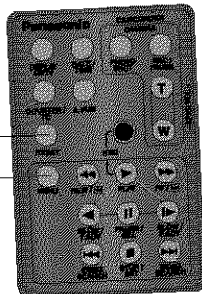

- 4** Press **II (PAUSE)** to start Audio Dubbing. "A.DUB ▷" indication appears.
- Connect the Palmcorder to the TV in order to monitor the sound. (p. 39)

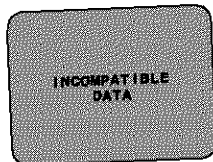

Only NTSC (National Television Standards Committee) recorded tapes can be audio dubbed. The following screen appears if the tape was not recorded in NTSC format.

- 5** Press **II (PAUSE)** to stop Audio Dubbing.

- If the microphone used for dubbing gets too near the speaker of your TV, a howling noise (feedback) may occur.
- If the tape position is in or was started in a blank section, you cannot use the A.DUB feature.

- A** Press **MENU** to display the VCR FUNCTIONS menu screen.

- B** Rotate **JOG KEY** to select **DISPLAY SETUP**, and then press **JOG KEY** to display the DISPLAY SETUP menu.

- C** Rotate **JOG KEY** to select **MEMORY DISPLAY**, and then press **JOG KEY** to set to MEMORY.

- D** Press **MENU** to exit MENU mode. Then, press **RESET** on the remote control to reset the Counter Memory to M 0:00.00.

Now, rewind to the editing start point, and continue with steps 2-5. The tape will now stop automatically at "M 0:00.00".

Copying your Tapes to S-VHS or VHS Cassette

Source (Playing)
Palmcorder

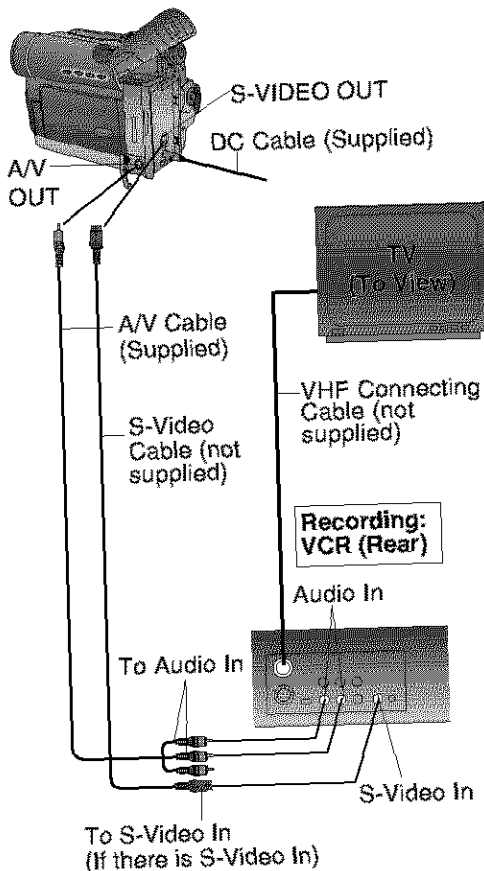

Monitor with your TV

- Turn the TV ON and select its VCR channel (either CH3 or CH4).
- Set the VCR/TV Selector on the recording VCR to VCR.

Before you begin

- Connect both Palmcorder and VCR to their power sources.
- Connect the Palmcorder to a VCR as illustrated left.
- Turn ON both units.
- **Set the recording VCR's Input Signal Selector to LINE.**
- Set the Palmcorder POWER to VCR.
- Before using S-VIDEO Connector, insert the DC Cable into the DC IN Terminal. (p. 16)

- 1** Insert a pre-recorded tape into the source (playing) Palmcorder and a blank tape, with record tab in place, into the target VCR (Recorder).
- 2** Press ► (PLAY) on the Palmcorder. When the tape reaches the point from which you want to start dubbing, press PAUSE.
- 3** Place the VCR into REC/PAUSE mode. (See VCR manual.)
- 4** Simultaneously, press PAUSE on both units to begin copying.
- 5** Press STOP on both units when copying is completed.

Note

- For technical reasons, dubbing a tape may reduce its quality.
- Press DISPLAY ON TV on the Palmcorder Remote Control to eliminate EVF/LCD Monitor indications.
- If the Time Code is displayed in the EVF or LCD monitor, it cannot be reset.
- Only the DATE/TIME, when displayed, will be recorded on the tape.

CAUTION:

Unauthorized exchanging and/or copying of copyrighted recordings may be copyright infringement.

Copying from Digital Equipment (dubbing)

High quality digital-to-digital copying can be accomplished if both Palmcoders incorporate the DV Input/Output (i.LINK) Connector (DV Interface cable (i.LINK) is not supplied).

Source (Playing) Palmcorder

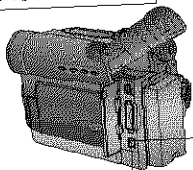

DV Input/Output (i.LINK) Connector

Recording Palmcorder

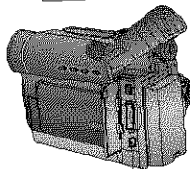

DV Interface Cable (i.LINK) (optional)

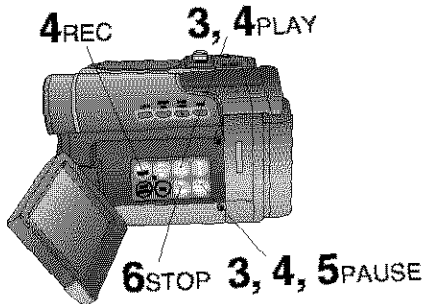

Optional

3, 4, 5 PAUSE

6 STOP

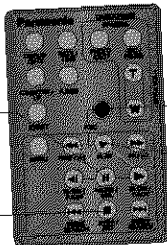

4 REC

3, 4 PLAY

Before you begin

- Connect both Palmcoders to their power sources.
- Connect the two Palmcoders using the DV Interface cable (i.LINK) (4-pin to 4-pin).
- Turn both Palmcoders ON.

- 1** Insert a pre-recorded tape into the source (playing) Palmcorder, and set **POWER** to **VCR**.
- 2** Insert a blank tape with the record tab closed into the target (recording) Palmcorder and set **POWER** to **VCR**.
- 3** Press **▶ (PLAY)** on the source Palmcorder. When the tape reaches the point from which you want to start dubbing, press **⏸ (PAUSE)**.
- 4** Hold down **● (REC)** and press **▶ (PLAY)** on the target (recording) Palmcorder. Press **⏸ (PAUSE)** to pause the tape at the starting point of the dub.
- 5** Simultaneously, press **⏸ (PAUSE)** on both units to begin dubbing.
- 6** Press **■ (STOP)** on the recording unit, and then press **■ (STOP)** on the playing unit to end dubbing.

Note

- When two Palmcoders are used for dubbing, it is recommended that the Remote Control (Optional) VCR1 or VCR2 setting be used to avoid improper operation.

CAUTION:

Unauthorized exchanging and/or copying of copyrighted recordings may be copyright infringement.

Card PhotoShot

You can record still images to a Memory Card.

Warning

- When using an M-CARD, DV Output will not function.

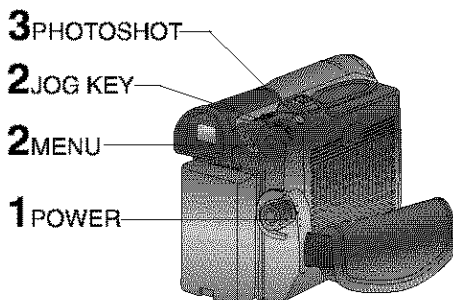

Image Resolution and Capacity (Supplied 8MB Memory Card)

REC Mode	Image Resolution	Capacity
FINE	1280 x 960	Approx. 30 images
NORMAL	640 x 480	Approx. 70 images

- The number of images given for each mode applies when all images are taken in same mode.
- You can change recording modes at any time before capturing an image.
- The number of images that can be captured may differ depending on the subject. After capturing an image, the number may not decrease, or it may decrease by two. This is normal.

Note

- 1280 x 960 PhotoShot image is interpolated from 640 x 480 image.
- Some artifacting, softened edges or picture noise may occur in Fine (1280 x 960) Mode.
- PhotoShot capture time for Fine Mode (1280 x 960) is approximately 10 seconds, and for Normal Mode (640 x 480) is approx. 5 seconds.

Before you begin

- Connect the Palmcorder to a power source. (pp. 15, 16)
- Set POWER to OFF before inserting a Memory Card. (p. 14)

- 1 Set **POWER** to **M-CARD**.
 - The POWER lamp lights red.
 - Be sure POWER is fully turned to M-CARD position.
 - "PLAY: PUSH PLAY KEY" is displayed for 10 seconds. (p. 51)
- 2 Press **MENU** to display **CARD SETUP** menu, then press **JOG KEY** to select **NORMAL** or **FINE**.



- Press MENU to exit this menu.

- 3 Press **PHOTOSHOT** to record an image.

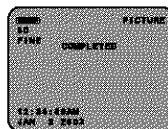

- The PhotoShot image is recorded to the Memory Card.
- When SHTR EFFECT is set to ON (Menu OSD: p. 109), still pictures are recorded with a visual shutter effect and click sound. If set to OFF, the still image will be displayed only.

Warning

- While "PROCESSING" is displayed, **DO NOT turn off the Palmcorder or unplug the AC Adaptor** (supplied) because this will cause irreversible damage to the memory.
- When recording DV Tape playback output to the Memory Card, only NORMAL mode is available. (p. 50)

Cautions for the Memory Card

- While Memory Card data is being read, do not remove it, turn off the power, or subject unit to vibrations and/or shocks.
- Do not leave the Memory Card in a place with high temperature, a place exposed to direct sunlight, or a place where electromagnetic waves and static electricity can be generated.
- Electromagnetic waves, static electricity, malfunction of the Digital Video Palmcorder or of the Memory Card itself could erase the data recorded on it. To prevent the loss of picture data, we recommend that you make a backup copy on the computer.
- Do not bend or drop the Memory Card as this could damage it or the captured contents.
- Do not touch the connector on the rear edge of the Memory Card with your fingers and take care that no dirt, dust or water enters it.
- Do not affix other labels to the Memory Card face or back as Card insertion/removal may become impossible.

Recording Images From a Tape

You can record still images from a cassette tape to a Memory Card.

4PHOTOSHOT

2POWER

3PLAY

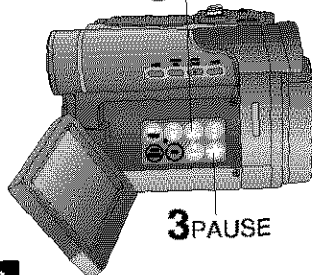

3PAUSE

Note

- When using this feature, the REC Mode will always be set to NORMAL (640 x 480).
- Even if Playback Digital Effects (MIRROR, MOSAIC, SEPIA, B/W) have been used, these effects do not affect the recording.
- Multi-Picture cannot be recorded. (p. 38)

Before you begin

- Connect the Palmcorder to a power source. (pp. 15, 16)
- Set POWER to OFF before inserting a Memory Card. (p. 14)

1 Repeat steps 1 and 2 on page 49.

2 Set POWER to VCR.

3 Press **▶** (PLAY) to start playback of the cassette tape. And then, press **II** (PAUSE) to select an image.

4 Press PHOTOSHOT to record the desired image to the Memory Card.



- When PHOTOSHOT is pressed in PLAY or SLOW mode, the screen goes to STILL mode.
- To playback the images of the Memory Card, see page 51.
- When Variable Speed Search is done (p. 35), this feature cannot be used.

5 Repeat steps 3~4 to record another image to the Memory Card.

Playback Still Images

You can view the images on the Memory Card.

3, 4
JOG KEY

1 POWER

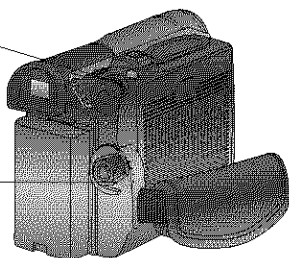

2 M-PLAY

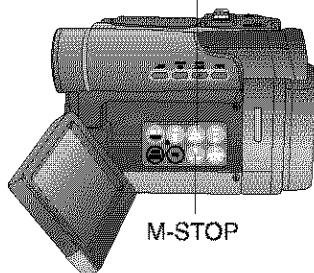

M-STOP

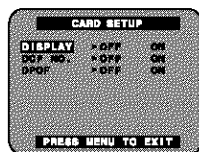

Note

- If the file number is changed, the Palmcorder cannot read the file data.
- This product is compliant with DCF (Design rule for Camera File System). Images saved on the Memory Card using other Digital Still Cameras that are compliant with DCF can be viewed on this product.

Warning

- While "PLEASE WAIT" is displayed, **DO NOT** turn off the Palmcorder or unplug the AC Adaptor (supplied) because this may cause irreversible damage to the Memory Card.

Before you begin

- Set POWER to OFF before inserting a recorded Memory Card. (pp. 49, 50)

1

Set POWER to M-CARD.

- "PLAY: PUSH PLAY KEY" is displayed for 10 seconds.

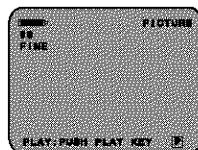

2

Press ► (M-PLAY) to display the Multi playback screen.

- "PLEASE WAIT" appears on-screen.
- Rotate JOG KEY to scroll through Multi image screen pages (6 images per page) and select an image.
- The selected image is underlined in green.

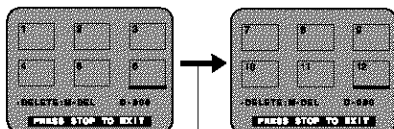

"PLEASE WAIT" is displayed.

- Press MENU to display CARD SETUP menu screen.
- Press ■ (M-STOP) to return to the Card PhotoShot REC Mode. (p. 49)

3

Press JOG KEY to display the

- selected image as a full-size screen.
- "PLEASE WAIT" appears on-screen.

4

Rotate JOG KEY to select BACK

(previous image), MULTI (Multi Image screen), or NEXT (next image).

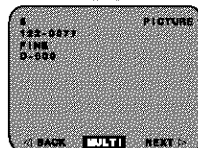

- Press ■ (M-STOP) to return to the Multi Playback screen.

Note

- The input to the Video Monitor and LCD Panel will not be displayed on the picture recorded of the Memory Card.

Delete Specific Images

You can delete unwanted images and increase the remaining image memory.

Warning:

Once deleted, images cannot be restored.

DELETE PAGE

Delete specific images from a page.

DELETE ALL

Delete all images. (p. 53)

FORMAT

Delete all data. (p. 54)

3, 4, 5
JOG KEY

1 POWER

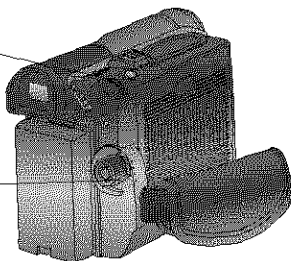

2 M-PLAY

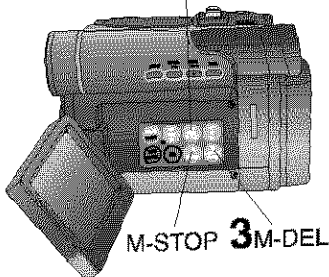

M-STOP 3 M-DEL

Before you begin

- Set POWER to OFF before inserting a recorded Memory Card. (pp. 49, 50)

- Set POWER to M-CARD.
 - "PLAY: PUSH PLAY KEY" is displayed for 10 seconds.
- Press ► (M-PLAY) to display the Multi playback screen.
 - "PLEASE WAIT" appears on-screen.
- Press II (M-DEL) to display the DELETE menu, then rotate and press JOG KEY to select **DELETE PAGE**.



- DELETE PAGE menu is displayed.

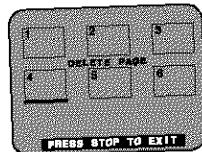

- Rotate and press JOG KEY to select and set the image to be deleted.
 - The selected image is underlined in pink.

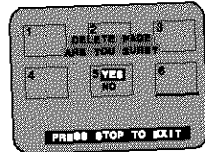

- Rotate JOG KEY to select **YES**, and press JOG KEY to delete the selected image.
 - To cancel delete, press ■ (M-STOP) or rotate and press JOG KEY to select NO.
 - "PLEASE WAIT" appears on-screen during deletion.
 - To delete other images, repeat steps 4-5.

Warning

- While deleting image, **DO NOT** turn off the Palmcorder or unplug the AC Adaptor (supplied) because this may cause irreversible damage to the Memory Card, resulting in reduced image storage capacity.

Delete All Image Pages

You can delete all images from the Memory Card easily with this operation.

Warning:

Once deleted, images cannot be restored.

2, 3
JOG KEY

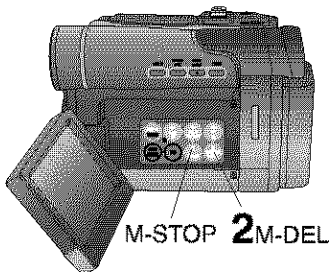
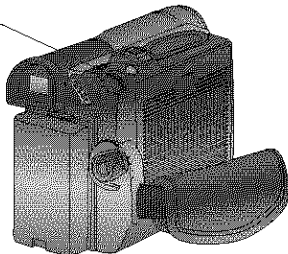

M-STOP 2 M-DEL

Warning

- While deleting images, **DO NOT** turn off the Digital Video Camcorder or unplug the AC Adaptor (supplied) because this may cause irreversible damage to the Memory Card, resulting in reduced image storage capacity.

Before you begin

- Set POWER to OFF before inserting a recorded Memory Card. (pp. 49, 50)

1 Do steps 1 and 2 on page 52.

2 Press **II** (M-DEL) to display the DELETE menu. Then, rotate and press JOG KEY to select **ALL**.



- The screen below is displayed.
- To cancel delete, press **■** (M-STOP) or rotate and press JOG KEY to select NO.

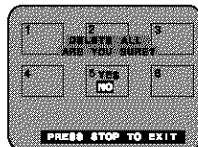

3 Rotate and press JOG KEY to select **YES**.

- "PLEASE WAIT" is displayed on the screen, and then "NO PICTURE" is displayed.

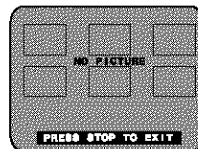

- Press **■** (M-STOP) to return to the Card PhotoShot REC Mode screen. (p. 49)

Format the Memory Card

You can easily format your Memory Card using this operation.

Warning:

Formatting permanently removes all image data.

2, 3
JOG KEY

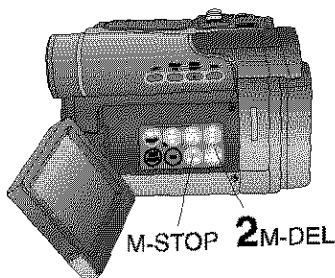
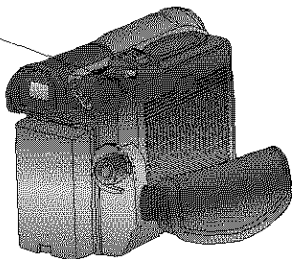

Before you begin

- Set POWER to OFF before inserting a recorded Memory Card. (pp. 49, 50)

1 Do steps 1 and 2 on page 52.

2 Press **II** (M-DEL) to display the DELETE menu, then rotate and press **JOG KEY** to select **FORMAT**.



- The screen below is displayed.
- To cancel format, press **■** (M-STOP) or rotate and press **JOG KEY** to select NO.

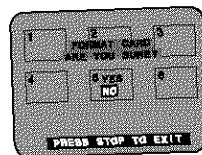

3 Rotate and press **JOG KEY** to select **YES**.

- "PLEASE WAIT" is displayed on the screen as all image data is deleted from Memory Card. Deletion is complete when "NO PICTURE" is displayed.

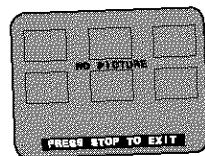

Warning

- While deleting image, **DO NOT** turn off the PalmCorder or unplug the AC Adaptor (supplied) because this may cause irreversible damage to the Memory Card, resulting in reduced image storage capacity.

- Press **■** (M-STOP) to return to the Card PhotoShot REC Mode screen. (p. 49).

DPOF Setting

You can select the images to be printed, the number of prints, and other print-related information (DPOF setting) on a Memory Card. "DPOF" stands for Digital Print Order Format, and since printing data can be added to images on the Memory Card, the Memory Card can be used with any system that supports DPOF.

VARIABLE:

You can select images recorded on the Memory Card and set the number of prints desired.

ALL1:

The number of prints recorded on the Memory Card is collectively set to 1.

ALLO:

The currently set number of prints is set to 0.

3, 4, 5, 6
JOG KEY

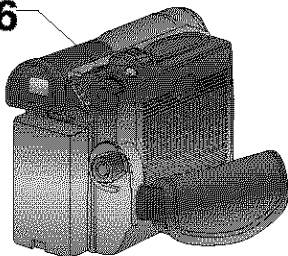

2 MENU

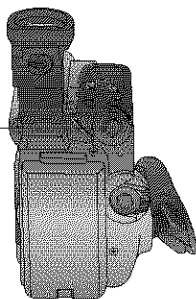

Before you begin

- Set POWER to OFF before inserting a recorded Memory Card. (pp. 49, 50)

- Do steps 1 and 2 on page 52.
- Press **MENU** to display the **CARD SETUP** menu screen.
- Rotate **JOG KEY** to select **DPOF**, then press **JOG KEY** to select **ON**.



- Rotate **JOG KEY** to select **VARIABLE**, then press **JOG KEY** to select **ON**.
 - DPOF SETTING menu screen is displayed on the screen.

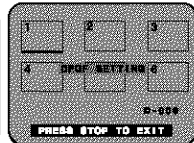

- Rotate and press **JOG KEY** to select the picture.
 - The selected image is underlined in green.
 - The cursor moves to "D-000".
- Rotate and press **JOG KEY** to set the number of prints.
 - The "●" mark is displayed. The "●" mark indicates pictures for which 1 or more prints have been set.
 - When printing one each of all the pictures, select "ALL1"; if not all the pictures are printed, select "ALLO".

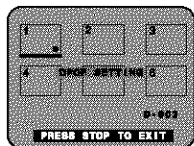

- Repeat steps 5 and 6 to set the other pictures.



Print mark is based on DPOF (Digital Print Order Format).

Transferring Your Images (Windows)

You can transfer images from your Palmcorder tape to your PC (Personal Computer).

System Requirements (for Palmcorder USB Device Driver/PHOTOVU MPEG4 Movie Messenger™ System)

- IBM PC/AT or compatible
- Pentium II Processor: 266 MHz or more
- RAM: 64 MB or more
- CD-ROM drive (for installation)
- Mouse or other pointing device
- Windows 98SE/Me/2000/XP preinstalled PC with USB port
- 2 MB minimum available hard disk space (for Palmcorder USB Device Driver)
- 15 MB minimum available hard disk space (for PHOTOVU/MPEG4 Movie Messenger™ System)
- 10 MB minimum available hard disk space (for Palmcorder File Converter)
- Minimum 120 MB of free hard disk space for Motion picture transfer from DV tape to PC (for PHOTOVU/MPEG4 Movie Messenger™ System)
- Video card that supports 16 bit color at 800 x 600 monitor resolution (for Palmcorder USB Device Driver, PHOTOVU/MPEG4 Movie Messenger™ System, and Palmcorder File Converter)
- Microsoft® Windows Media™ Player 6.4 (for Windows 2000 users: Microsoft® Windows Media™ Player 7.1) or later (for PHOTOVU/MPEG4 Movie Messenger™ System)
 - * If Windows Media Player 6.4 (for Windows 2000 users: Windows Media Player 7.1) or later is not installed in your PC, please download and install Windows Media Player from the Microsoft Home Page: <http://www.microsoft.com/>

***Satisfy the conditions recommended by Microsoft for Windows XP.**

Palmcorder USB Device Driver/Web Camera/SD Drive

Install Palmcorder USB Device Driver.

You can transfer motion/still picture to your PC using Movie Messenger, Web Camera or SD Drive via USB. Using this driver allows data communication between the Memory Card and PC.

PHOTOVU/MPEG4 Movie Messenger™ System

Install PHOTOVU/MPEG4 Movie Messenger™ System.

You can transfer motion/still pictures to your PC from a Mini DV Tape via USB and i.LINK.

Palmcorder File Converter

Install File Converter.

You can convert the JPEG data of your PC into the DCF (Design rule for Camera File System) data, and transfer this data to your Palmcorder via USB. Using this driver allows data communication between the Memory Card and PC.

Software Installation (Windows 98SE/Me/2000/XP)

Caution

- Please install Palmcorder USB Device Driver first before connecting the Palmcorder and your PC using USB Cable. Once Palmcorder USB Device Driver is installed, you must restart your computer for installation to take effect.
- Restarting the computer not only applies to Driver installation, but must be done whenever "Restarting Windows" **a** is displayed after software or driver install/uninstall.
- For Windows XP users, when installing Palmcorder USB Device Driver, a message, such as the one below, is displayed. **The following message **b** is displayed. However, testing by the manufacturer has confirmed functionality of this Palmcorder with Windows XP. Click [Continued Anyway] and proceed.**

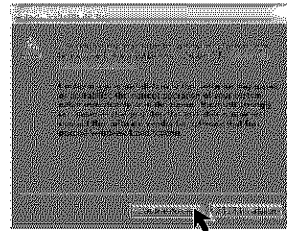
a**b**

- 1** Turn on the PC (Personal Computer) and start up Windows.
- 2** Insert the supplied Software CD-ROM into the CD-ROM drive.
- 3** Click the icon you want to install. Please install the Palmcorder USB Device Driver first and follow the instructions listed under "Caution".

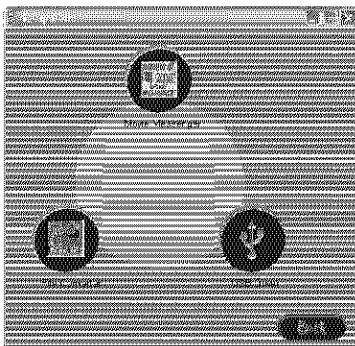

Palmcorder USB Device Driver

- For Movie Messenger
- For Web Camera
- For SD Drive

: Click



PHOTOVU/MPEG4 Movie Messenger™ System

: Click



Palmcorder File Converter

: Click



- 4** Follow the instructions as they appear on your PC screen.

Note

- If a window does not appear automatically, click the "Start" button on your desktop and then click "Run". When the Run box is open, type in "D:\InstMenu.exe" where "D:" is the drive letter of your CD; then click "OK".
- If you attempt to install the next Software before the previous Software installation is completed, "Error" may appear. In this case, click [OK] and install the next Software from the menu.

Notes on PHOTOVU/MPEG4 Movie Messenger™ System operation

- For PHOTOVU/MPEG4 Movie Messenger™ System, do not connect the i.LINK and USB terminals to the Palmcorder at the same time.
- Make sure Palmcorder power is not shut off during use as your PC system may become unstable. Therefore, the AC Adaptor should be used as the power source. (Be especially careful when recording in M-CARD or CAMERA mode as the power eventually shuts off automatically if a tape is inserted.)
- For PHOTOVU/MPEG4 Movie Messenger™ System, if the play, stop, fast forward, and rewind functions are operated using the Palmcorder buttons, the image may not be captured properly. Use Palmcorder Operation Buttons displayed on the PC screen.

Verifying the driver (Windows 98SE/Me/2000/XP)

Note

- Verify the driver while Palmcorder is connected to the computer.

PHOTOVU/MPEG4 Movie Messenger™ System (VCR Mode)

[This screen is an example (Windows 2000)]

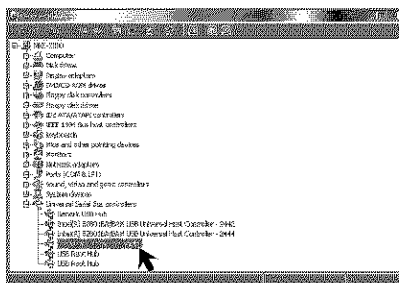

1 Click "Start," "Settings," and "Control Panel."

2 Double-click on "System", verify [Panasonic Digital Palmcorder] is displayed in [Universal Serial Bus controllers] of [Device Manager] of [Hardware].

Palmcorder USB Device Driver/Web Camera (CAMERA Mode)

[This screen is an example (Windows 2000)]

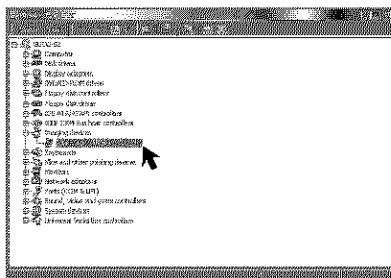

1 Click "Start," "Settings," and "Control Panel."

2 Double-click on "System", verify [Panasonic USB Video Camera] is displayed in [Imaging Devices] of [Device Manager] of [Hardware].

Palmcorder USB Device Driver/SD Drive, Palmcorder File Converter (M-CARD Mode)

[This screen is an example (Windows 2000)]

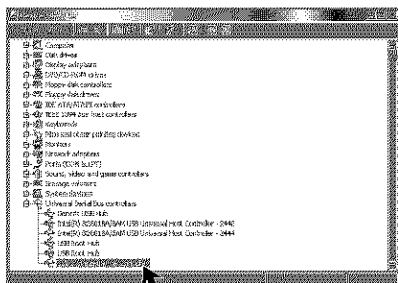

1 Click "Start," "Settings," and "Control Panel."

2 Double-click on "System", verify [USB Storage Device Controller]* is displayed in [Universal Serial Bus controllers] of [Device Manager] of [Hardware].

* If you are using Windows 98SE, [MATSUSHITA USB Storage Device Controller] will be displayed.

Uninstalling Application Software

[This screen is an example (Windows 2000)]

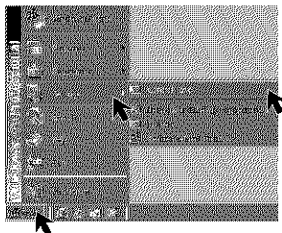

1 Click "Start," "Settings," and "Control Panel."

2 Double-click on "Add/Remove Programs" in the "Control Panel."

3 Select the application software you want to remove, and then click [Change/Remove]*.

* If you are using Windows 98SE or Me, click [Add/Remove].

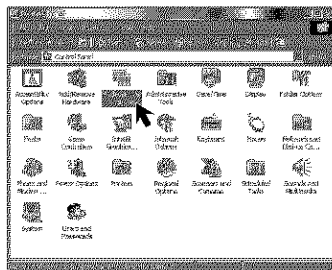

Connection (for PHOTOVU/MPEG4 Movie Messenger™ System)

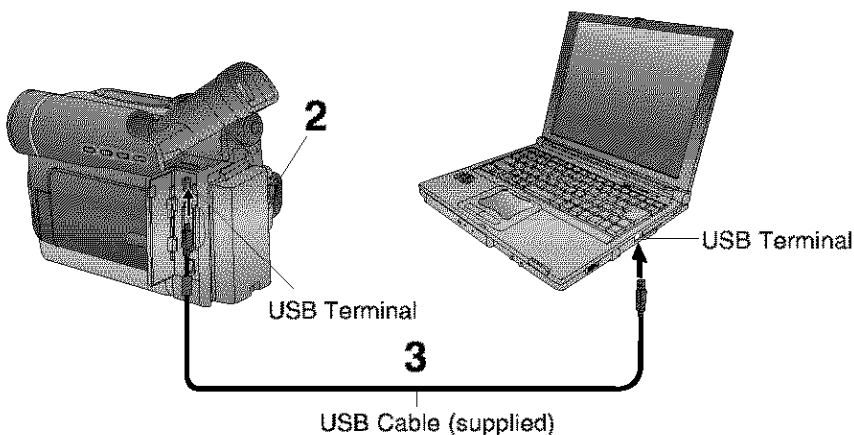

1 Turn on your PC.

2 Set the Palmcorder POWER to VCR.

For Windows XP users

3 Connect the Palmcorder to your PC (Windows) using the USB Cable (supplied).

- "CAPTURE" appears in the EVF or the LCD monitor.
- The "Found New Hardware Wizard" screen of Windows is displayed. Follow the instructions as they appear on your PC screen.

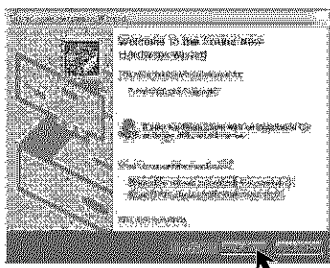

Note

- For extended use, the AC Adaptor should be used as a power source.

For Windows 98SE/Me/2000 users

- 3** Connect the Palmcorder to your PC (Windows) using the USB Cable (supplied).
- "CAPTURE" appears in the EVF or the LCD monitor.
 - The "Found New Hardware" screen of Windows is displayed.

Note

- For extended use, the AC Adaptor should be used as a power source.

To disconnect USB Cable safely (Windows 2000/XP)

If USB Cable is disconnected while computer is on, error message may appear. In such a case click [OK] and close the dialog box. By following the steps you can disconnect the cable safely.

[This screen is an example (Windows 2000)]

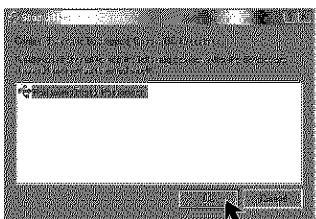
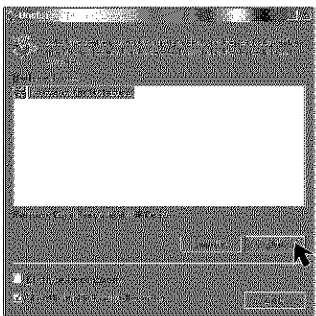

- 1** Double-click the  icon in the task tray.

- 2** Select [Panasonic Digital Palmcorder] and click [Stop].

- 3** Verify [Panasonic Digital Palmcorder] is selected and click [OK].

- 4** Click [OK].
- You can safely disconnect the cable.

Note

- Some OS, such as Windows 98SE or Me, may not show the icon indication that you may safely disconnect in task tray. (OS may be set not to show) Close PHOTOVU/MPEG4 Movie Messenger™ System, then disconnect the USB Cable.

Running the PHOTOVU/ MPEG4 Movie Messenger™ System*

* **PHOTOVU:** You can transfer Still images from your Palmcorder tape to a PC.

MPEG4 Movie Messenger™ System:
You can transfer Motion images from your Palmcorder tape to a PC.

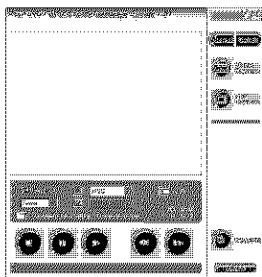
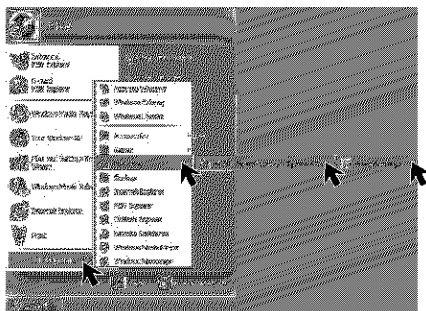

Before you begin

- Insert a recorded tape. (p. 12)

- 1** Set Palmcorder **POWER** to **VCR**.
- 2** Connect the Palmcorder to your PC using the **USB Cable (supplied)** or **DV Interface Cable (i.LINK) (not supplied)**. (pp. 60, 61, 72)
- 3** Click on "Start," "(All) Programs," "Panasonic," "MPEG4 MovieMessenger System 1.01," then "MovieMessenger."
- 4** "PHOTOVU/MPEG4 MovieMessenger System 1.01" is opened.

Note

Refer to **Help** on program for information about application operations and Error messages.

While PHOTOVU/MPEG4 Movie Messenger™ System is running, do not perform the following operations...

The PC system may become unstable.

- Change the screen area or color pallet in the Display Properties window.
- Turn the Palmcorder power switch **ON** or **OFF** while connecting the Palmcorder to your PC using the **USB Cable** or **DV Interface Cable (i.LINK)**.
- Change the Palmcorder power switch (**VCR/CAMERA**).
*You must first close the application.
- Connect/disconnect the **DV Interface Cable (i.LINK)**.
- Connect/disconnect the **USB Cable**.

Using Tape Image Data (USB)

By connecting the Palmcorder and PC with the USB Cable, you can transfer Motion images and Still images saved on the DV Tape directly to your PC.

Note

- Detail mode cannot be used with a USB connection.
- Deactivate your PC ScreenSaver or this application may shutdown during image capture.

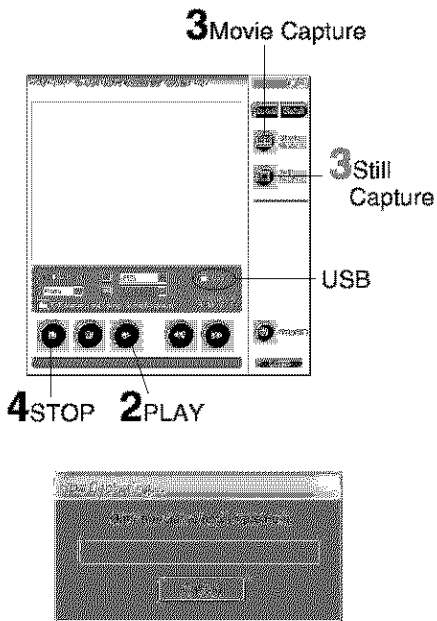

To capture Still images

- 3 Click on [Still Capture] at the point you wish to capture an image.
 - Repeat step 3 to continue capturing images.
 - Captured Still images are saved to the PC, and you can playback the saved images on the View Manager. (p. 64)

Before you begin

- Insert a recorded tape. (p. 12)
- Make Palmcorder-PC connections. (pp. 60, 61)
- Turn your PC on. (p. 60)
- Set Palmcorder POWER to VCR.

- 1 Repeat steps 1-4 on page 62 to run the PHOTOVU/MPEG4 Movie Messenger™ System.

Note

- When the USB Cable is connected, the input display will automatically become USB. If it is not USB, please confirm the connection. Then, close and restart the software.

- 2 Click ► (PLAY) on PC screen to playback the DV tape.
 - The playback screen cannot be viewed on the PC. Please use the LCD monitor on the Palmcorder for confirmation.

To capture Motion images

- 3 Click on [Movie Capture] at the start point you wish to capture a Motion image.
 - "Now capturing a movie" is displayed.
- 4 Click STOP to end capture.
 - "Now Searching..." is displayed.
 - The DV Tape is rewound to the point at which the capture was started. The Motion image is then transferred to the PC.
 - "Data transfer is now in progress" is displayed on the PC screen.
 - The maximum capture time is approx. 30 seconds. Capture stops automatically at the end of 30 seconds.

Note

- Motion images cannot be captured if data contains the following...
 - A change between 12 bit and 16 bit.
 - A change between SP and LP mode.
- During transfer to the PC, the Motion images will not be displayed on the PC screen.
- Transfer takes from about 30 to 50 seconds for every 1 second of the Motion image when using USB connection.

- 5 To capture other Motion images, repeat steps 3-4.

Playing back the saved Motion and Still images

You can play back the saved Motion images and Still images (p. 63) for confirmation.

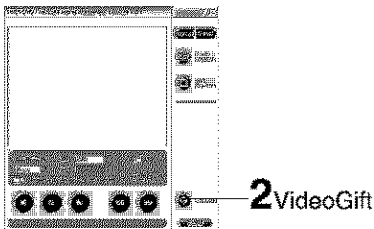

3 View Manager

4 All Picture

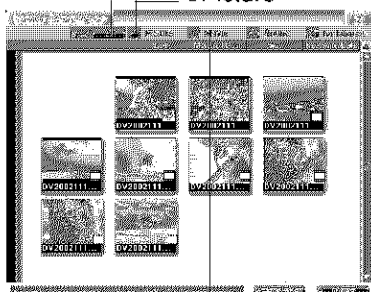

4 Movie

All:
Still image, Motion image and Sound data are displayed.

Picture:
Still image data (*.BMP, *.JPG) is displayed.

Movie:
Motion Image data (*.AVI, *.WMV) is displayed.

Sound:
Sound image data (*.WAV) is displayed.

For Internet:
The data (*.WMV, *.JPG) is displayed.

1 Repeat steps 1~4 on page 62 to run the PHOTOVU/MPEG4 Movie Messenger™ System.

2 Click [VideoGift] to display the VideoGift screen.
• The image captured last is displayed in the VideoGift screen.

Caution for Windows 2000 users

• If "Unable To Locate DLL" warning indication is displayed, please see page 89.

3 Click [View Manager] to display the View Manager screen.

To view Motion images

4 Click on [Movie].
• The first frame of each Motion image will be displayed as a list.

5 Double click on the desired Motion image to display the playback screen.
• Click ▶ to start Motion image playback.

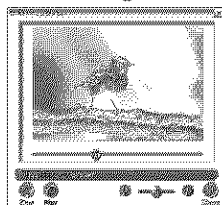

Note

• You can also playback a motion image by simply pointing at the thumbnail with your mouse. Duration, Rec Time, and size are displayed as well. (Only size for still images.)

To view Still images

4 Click on [All] or [Picture] to display the Still image list.

5 Double Click on the desired image to open it.

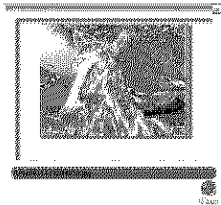

Note

• If the image cannot be opened, please refer to the software Help menu.

VideoGift Screen

You can use these features using the VideoGift Screen.

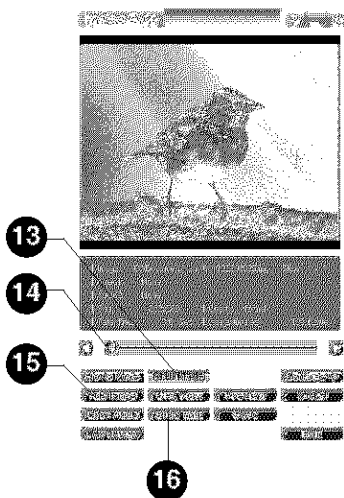
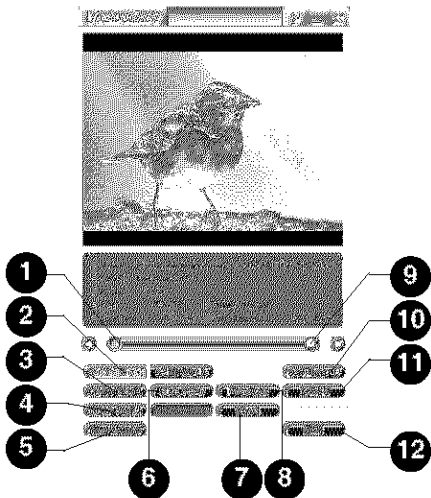

- 1 Slider**
Drag the pointer of the playback start position.
- 2 Movie Mode**
You can display motion images.
- 3 Open Movie**
You can open folders containing video files (*.AVI, *.WMV).
- 4 Open Audio**
You can open folders containing audio files (*.WAV). Valid only when the file is opened in the VideoGift screen.
- 5 View Manager**
You can open the View Manager screen.
- 6 Org. View**
You can play original moving image: (Uncompressed moving image.)
- 7 Save**
You can save the compressed images (*.WMV) to your hard disk.
- 8 Preview**
You can preview the compressed motion image.
- 9 Slider**
Drag the pointer of the playback end position.
- 10 Settings**
You can open the "Compression Settings" screen. (p. 70)
- 11 E-mail**
You can attach the compressed image to your e-mail.
- 12 Exit**
Exits VideoGift screen.
- 13 Still Mode**
You can display still images.
- 14 Slider**
When several still images are opened in the VideoGift screen, a slide show of the images can be done.
- 15 Add Image**
You can open the folder containing a desired still image to add images.
- 16 Slide Edit**
A collection of still images can be edited as a slide show.

Using the VideoGift Screen

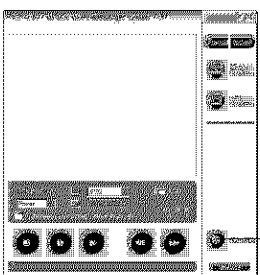

2 VideoGift

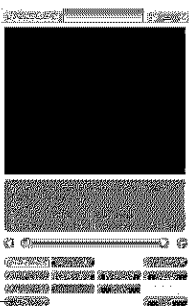

3 View Manager

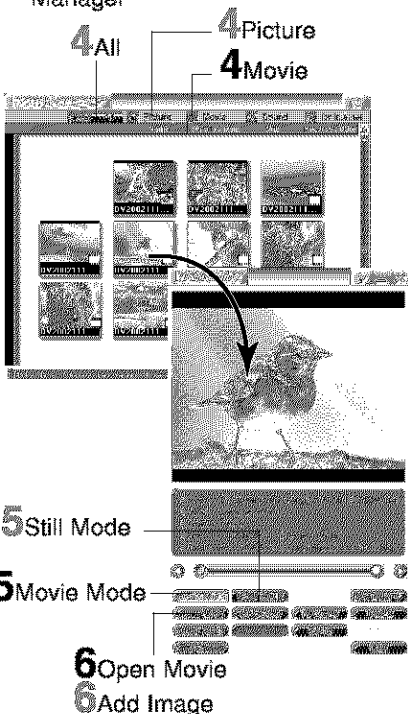

4 All
4 Picture
4 Movie

5 Still Mode

5 Movie Mode

6 Open Movie

6 Add Image

- 1** Repeat steps 1~4 on page 62 to run the PHOTOVU/MPEG4 Movie Messenger™ System.
- 2** Click [VideoGift] to display the VideoGift screen.
 - The image captured last is displayed in the VideoGift screen.
- 3** Click [View Manager] to display the View Manager screen.

Caution for Windows 2000 users

- If "Unable To Locate DLL" warning indication is displayed, please see page 89.

Using a Motion Image on the VideoGift Screen

- 4** Click on [Movie] to display a Motion image list on the View Manager screen.
- 5** Click on [Movie Mode] on the VideoGift screen.
- 6** Select the Motion image from the View Manager screen, then drag and drop the image to the "VideoGift" screen.
 - By clicking [Open Movie], you can add the saved motion images on your PC hard disk. You can also select the file by dragging and dropping from Windows Explorer.
 - You can use the VideoGift features (p. 65) on the VideoGift screen.

Using a Still Image on the VideoGift Screen

- 4** Click on [All] or [Picture] to display a Still image list on the View Manager screen.
- 5** Click on [Still Mode] on the VideoGift screen.
- 6** Select the Still image from the View Manager screen, then drag and drop the image to the "VideoGift" screen.
 - When clicking [Add Image], you can add the saved still images on your PC hard disk.
 - If selecting a frame from a motion image, See "Selecting a Frame from a Motion Image" on page 71.
 - You can use the VideoGift features (p. 65) on the VideoGift screen.

Setting the Mail Software

It is possible to set the mail software to start up automatically when [E-Mail] of VideoGift is clicked.

Note

The e-mail Software must support MAPI (Messaging Application Programming Interface).

Below are some e-mail Software programs which support MAPI:

Microsoft Outlook, Microsoft Outlook Express, Netscape Messenger:

- Outlook(R) Express 5x, Outlook97, Outlook98, Outlook2000
- Outlook Express 4x
- Other MAPI applications [Netscape(R) Messenger 4.5x, and so on]

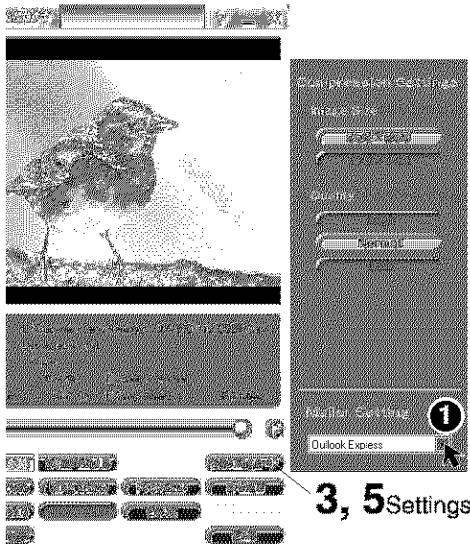

1 Repeat steps 1~4 on page 62 to run the PHOTOVU/MPEG4 Movie Messenger™ System.

2 Click [VideoGift] to display the VideoGift screen.

- The image captured last is displayed in the VideoGift screen.

Caution for Windows 2000 users

- If "Unable To Locate DLL" warning indication is displayed, please see page 89.

3 Click [Settings] to display the Compression Settings/Mailer Settings screen.

4 Click **1** to set the mail software.

- The mail software installed in the computer will be displayed.
- You can select Outlook Express or other software.

Note

- If selecting software other than Outlook Express and Microsoft Outlook, click [Other]. From the file dialog box, select the executable file (*.exe) of the mail software application and then click [Open].

5 Click [Settings] to close the Compression Settings/Mailer Settings screen.

Attaching captured Motion and Still images to your e-mail

You can easily transfer and compress your Motion images as attachments to your e-mail.

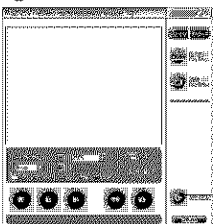

2 VideoGift

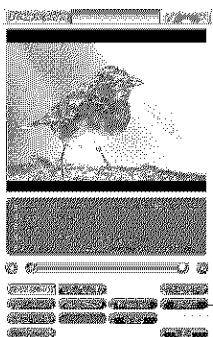

4, 4 E-Mail

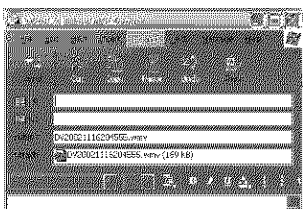
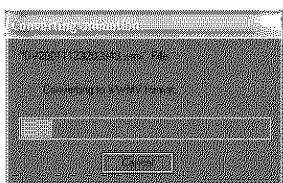

Note

- Refer to Help for information about application operations and Error messages.
- If your e-mail software is not supported by MAPI, pressing the [E-Mail] button will automatically open the folder containing the compressed file. To attach, drag and drop the file into your e-mail.

Before you begin

- Insert a recorded tape. (p. 12)
- Make Palmcorder-PC connections. (pp. 60, 61)
- Turn your PC on. (p. 60)
- Set Palmcorder POWER to VCR.

1

Repeat steps 1-4 on page 62 to run the PHOTOVU/MPEG4 Movie Messenger™ System.

2

Click [VideoGift] to display the VideoGift screen.

- The image captured last is displayed in the VideoGift screen.

Caution for Windows 2000 users

- If "Unable To Locate DLL" warning indication is displayed, please see page 89.

Attaching Motion images to e-mail

3

Repeat steps 4-6 on page 66 to select a Motion Image.

- If sending a portion of a Motion image, see "Sending a Portion of a Motion Image" on page 69.
- To compress a Motion image, see "Setting the Size and Quality of Motion and Still Image" on page 70.

4

Clicking on [E-Mail] will convert the selected image to WMV format.

Note

- Follow the instructions as they appear on your PC screen.

Attaching Still images to e-mail

3

Repeat steps 4-6 on page 66 to select a Still Image.

- To compress a Still image, see "Setting the Size and Quality of Motion and Still Image" on page 70.

4

Clicking on [E-Mail] will convert the selected image to WMV format.

Note

- Follow the instructions as they appear on your PC screen.

Sending a Portion of a Motion Image

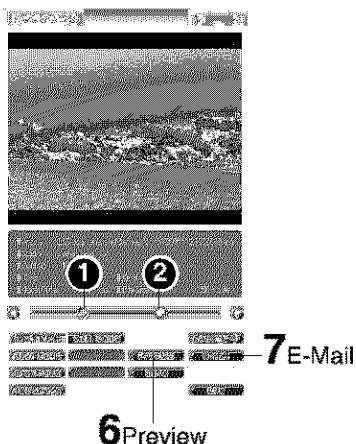

- 1** Repeat steps 1-4 on page 62 to run the PHOTOVU/MPEG4 Movie Messenger™ System.
 - 2** Click [VideoGift] to display the VideoGift screen.
 - The image captured last is displayed in the VideoGift screen.
- Caution for Windows 2000 users**
- If "Unable To Locate DLL" warning indication is displayed, please see page 89.
- 3** Select a Motion image. (Continue with steps 4-6 on page 66 to specify the portion to be played.)
 - 4** Drag pointer **1** to start position.
 - 5** Drag pointer **2** to end position.
 - 6** Click [Preview]. (To set size/quality, do steps 4 and 5 on page 70.)
 - To save the image to your PC, click [Save].
 - 7** Click [E-Mail] and then send the e-mail message. (p. 68)

Slide-Show Edit

A collection of still images can be edited as slides.

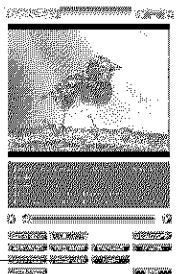

4 Slide Edit

- 1** Repeat steps 1-4 on page 62 to run the PHOTOVU/MPEG4 Movie Messenger™ System.
 - 2** Click [VideoGift] to display the VideoGift screen.
 - The image captured last is displayed in the VideoGift screen.
- Caution for Windows 2000 users**
- If "Unable To Locate DLL" warning indication is displayed, please see page 89.
- 3** Select the Still images. (See steps 4-6 on page 66.)
 - The selected Still images are displayed on the VideoGift screen.
 - 4** Click on [Slide Edit] on the VideoGift screen.
 - The "Slide-show Edit" screen is displayed.
 - 5** Edit slides.
 - Use "Help" for detailed instructions.

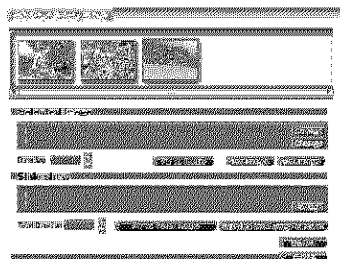

PC Connection

Setting the Size and Quality of Motion and Still Image

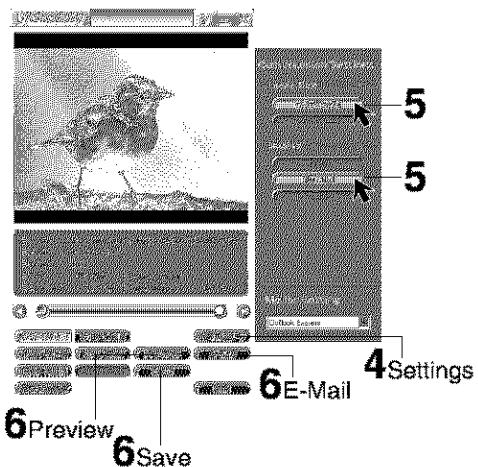

Size of Compressed File

Image Quality	Image Size	
	352 x 288 pixels	176 x 144 pixels
High	3000 KB/min	1000 KB/min
Normal	2000 KB/min	600 KB/min
Low	1000 KB/min	360 KB/min

- 1** Repeat steps 1~4 on page 62 to run the PHOTOVU/MPEG4 Movie Messenger™ System.
- 2** Click [VideoGift] to display the VideoGift screen.
 - The image captured last is displayed in the VideoGift screen.
- Caution for Windows 2000 users**
 - If "Unable To Locate DLL" warning indication is displayed, please see page 89.
- 3** Select a Motion or Still image. (See steps 4~6 or 4~6 on page 66.)
 - The selected Motion or Still image is displayed on the VideoGift screen.
- 4** Press [Settings] to display the "Compression Settings" screen.
- 5** Set the Image Size and Quality.
 - See "Size of Compressed File" to the left.
- 6** Click [Save] to save the compressed image to your PC.
 Click [Preview] to view the compressed Motion Image.
 Click [E-mail] to send the e-mail message.

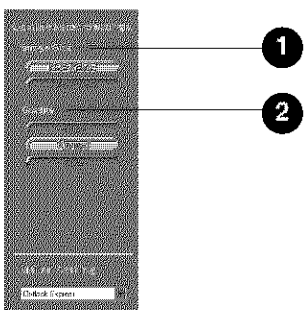

- 1** Image Size
You can select the image size (352 x 288 or 176 x 144).
- 2** Quality
You can select the image quality (High, Normal, Low).

Selecting a Frame from a Motion Image

This screen is displayed when an individual frame from a moving image file is to be added as a still image.

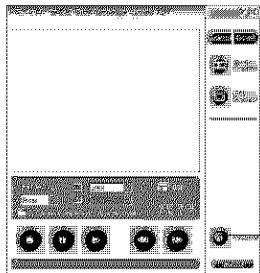

2 VideoGift

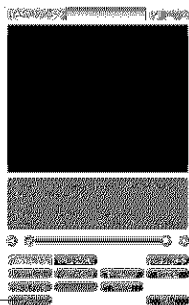

3 View Manager

4 Movie

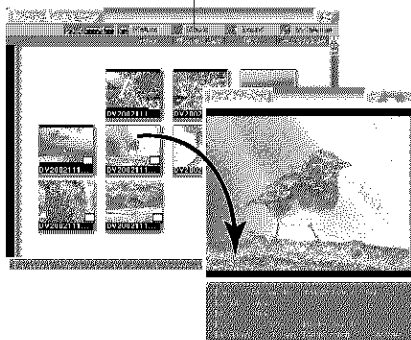

5 Still Mode

9 Preview

9 Save

9 E-Mail

1 Repeat steps 1~4 on page 62 to run the PHOTOVU/MPEG4 Movie Messenger™ System.

2 Click [VideoGift] to display the VideoGift screen.
 • The image captured last is displayed in the VideoGift screen.

Caution for Windows 2000 users

• If "Unable To Locate DLL" warning indication is displayed, please see page 89.

3 Click [View Manager] to display the View Manager screen.

4 Click on [Movie] to display a Motion image list on the View Manager screen.

5 Click on [Still Mode] on the VideoGift screen.

6 Select the Motion image from the View Manager screen, then drag and drop the image to the "VideoGift" screen.
 • The "Select Frame" screen is displayed.

7 Drag the pointer ① to select a desired frame.

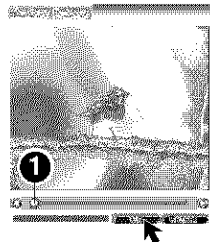

8 Click [OK].

9 Click [Save] to save the compressed image to your PC.

Click [Preview] to view the compressed Motion Image.

Click [E-mail] to send the e-mail message.

Transferring Your Images (i.LINK) (Windows)

PC Connection with DV Interface Cable (i.LINK)

A video clip can be transferred directly to your PC (Personal Computer) via a DV Interface Cable (i.LINK) (not supplied) using products and software from a number of video editing software companies.

Using products from video editing software companies allows you to capture and edit video clips using the DV Interface (i.LINK).

Our DVC being OHCI compliant should have no problem working with any OHCI compliant Firewire Card/video - Editing software package.

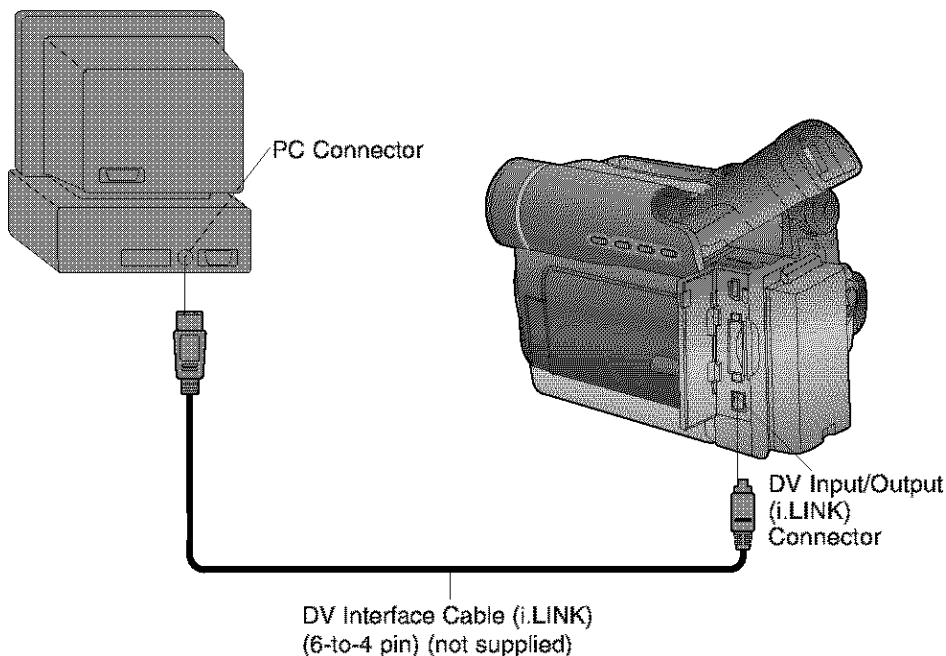

Note

- PC must be equipped with an i.LINK terminal.
- During Palmcorder playback, do not disconnect the DV Interface Cable (i.LINK) or turn the Palmcorder off as this may cause a PC hang-up error.
- For PHOTOVU/MPEG4 Movie Messenger™ System, do not use 2 i.LINK terminals on your PC at the same time.
- PHOTOVU/MPEG4 Movie Messenger™ System i.LINK (DV) operates normally with Windows 98SE or later operating system.
- PHOTOVU/MPEG4 Movie Messenger™ System i.LINK connection may not work with some DV Interface boards. In this case, use the software included with the board.
- 1394 (i.LINK) Interface must conform to OHCI (Open Host Controller Interface Specification).

Using Tape Image Data

By connecting the Palmcorder and PC with the DV Interface Cable (i.LINK), you can transfer Motion images and Still images saved on the DV Tape directly to your PC.

Note

- If PHOTOVU/MPEG4 Movie Messenger™ System does not work, please refer to note on page 72.
- Deactivate your PC ScreenSaver or this application may shutdown during image capture.

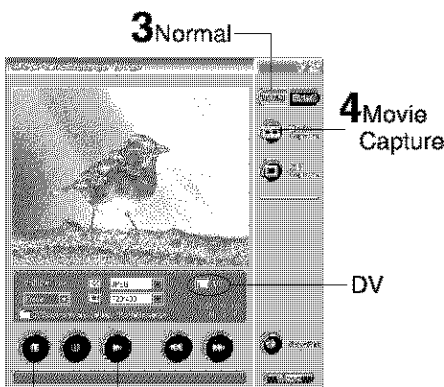

STOP **2** PLAY

How to insert the DV Interface Cable (i.LINK)

- Set Palmcorder POWER to VCR.
- Connect the Palmcorder to your PC using the DV Interface Cable (i.LINK) (not supplied).
- Start up the PHOTOVU/MPEG4 Movie Messenger™ System.

How to remove the DV Interface Cable (i.LINK)

- Close the PHOTOVU/MPEG4 Movie Messenger™ System.
- Remove the DV Interface Cable (i.LINK) from the Palmcorder.
- Set Palmcorder POWER to OFF.

Before you begin

- Insert a recorded Tape. (p. 12)
- Make Palmcorder-PC connections. (p. 72)
- Turn your PC on.
- Set Palmcorder POWER to VCR.
- **Run the Software after the DV Interface Cable (i.LINK) has been connected to the Palmcorder.**

- 1 Repeat steps 1~4 on page 62 to run the PHOTOVU/MPEG4 Movie Messenger™ System.**

Note

- When the DV Interface Cable (i.LINK) is connected, the input display will automatically become DV. If it is not DV, please confirm the connection. Then, close and restart the software.
- When using Windows XP, "Windows Movie Maker" may open automatically. If so, close "Windows Movie Maker" and "Movie Messenger", and open "Movie Messenger" again.

- 2 Click ► (PLAY) button on PC screen to playback the DV tape.**
 - Please use the LCD monitor on the Palmcorder or PC screen for confirmation.

To capture Motion images

[When selecting Normal]

- 3 Click on [Normal].**
- 4 Click on [Movie Capture] at the point you wish to capture a Motion image. Click on [STOP] to end capture.**
 - The image is transferred to the PC in real time.
 - The maximum capture time is approx. 3 minutes.
 - When capturing data containing changes between 12 bit and 16 bit and/or between SP and LP mode, a separate file will be made for each mode.
 - Please refer to pages 64~71 for other functions.

(Continued on next page.)

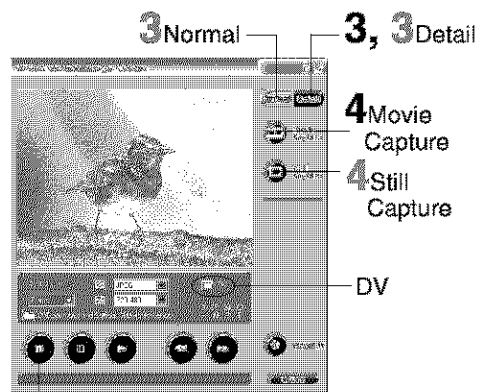

6 STOP

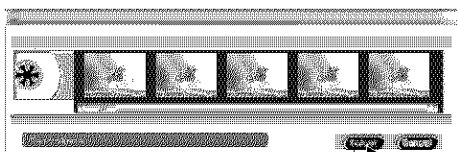

5, 7, 5 Select



[When selecting Detail]

Note

- Detail mode lets you specify the start and end frames for the video segment you want to capture and save.

3 Click on [Detail].

4 Click on [Movie Capture] at the point where you wish to capture a Motion image.

- The screen to select the start frame is displayed.

5 Select the start frame for the segment to be captured select one frame, and click [Select].

- "Now Searching..." is displayed, and the DV tape is rewound to the point at which the capture was started.
- "Now capturing a movie." is displayed.

6 Click on [Stop] to end capture.

- The screen to select the end frame is displayed.

7 Select the end frame for the segment to be captured, select one frame, and click [Select].

- "Saving a file..." is displayed.
- The image is transferred to the PC in real time.

To capture Still images

[When selecting Detail]

3 Click on [Detail].

4 Click on [Still Capture] at the point you wish to capture images.

- The screen to select frames is displayed.

5 Select the frame for the segment to be captured select frames, and click [Select].

- Repeat steps 4 and 5 to continue capturing images.
- Captured Still images are saved to the PC, and you can playback the saved images on the View Manager. (P. 64)

To capture Still images

[When selecting Normal]

3 Click on [Normal].

4 Click on [Still Capture] at the point you wish to capture an image.

- Repeat step 4 to continue capturing images.
- Captured Still images are saved to the PC, and you can playback the saved images on the View Manager. (P. 64)

Connection (for Palmcorder USB Device Driver/SD Drive)

Note

- For Palmcorder USB Device Driver/SD Drive, do not connect the i.LINK and USB terminals to the Palmcorder at the same time.

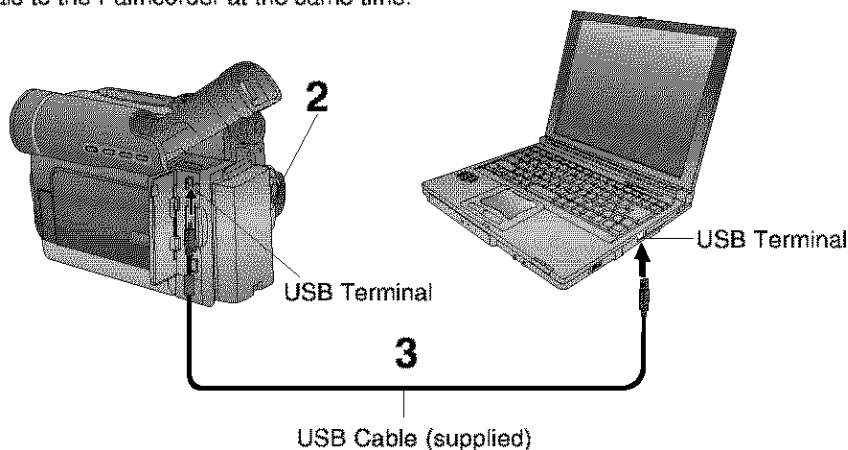

1 Turn on your PC.

2 Set the Palmcorder POWER to M-CARD.

For Windows XP users

3 Connect the Palmcorder to your PC (Windows) using the USB Cable (supplied).

- “CONNECT WITH PC” and “STORAGE” appears in the EVF or the LCD monitor.
- The “Found New Hardware Wizard” screen of Windows is displayed.

Follow the instructions as they appear on your PC screen.

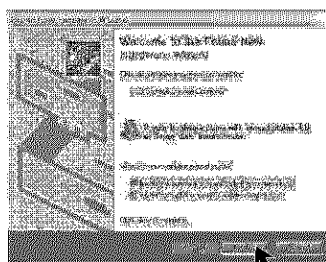

Note

- When connecting for the first time using Windows XP, the OS installation CD may be required. Follow the instructions as they appear on your PC screen.
- For extended use, the AC Adaptor should be used as a power source.

For Windows 98SE/Me/2000 users

- 3** Connect the Palmcorder to your PC (Windows) using the USB Cable (supplied).
- "CONNECT WITH PC" and "STORAGE" appears in the EVF or the LCD monitor.
 - The "Found New Hardware" screen of Windows is displayed.

Note

- For extended use, the AC Adaptor should be used as a power source.

To disconnect USB Cable safely (Windows Me/2000/XP)

If USB Cable is disconnected while computer is on, error message may appear. In such a case click [OK] and close the dialog box. By following the steps you can disconnect the cable safely.

[This screen is an example (Windows 2000)]

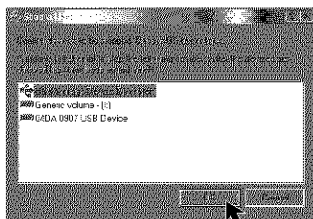
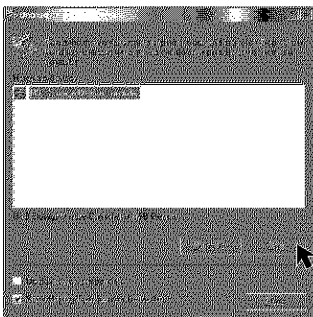

- 1** Double-click the  icon in the task tray.

- 2** Select [USB Storage Device Controller]* and click [Stop].

- 3** Verify [USB Storage Device Controller]* is selected and click [OK].

- 4** Click [OK].
- You can safely disconnect the cable.

* If you are using Windows Me, [USB Disk] will be displayed.

Note

- Some OS, such as Windows 98SE, may not show the icon indication that you may safely disconnect in task tray. (OS may be set not to show) After the [ACCESS] display disappears from the EVF or LCD monitor you may disconnect the USB Cable.

Using Memory Card Image Data

By connecting the Palmcorder and PC with the USB, you can transfer Still images saved on the Memory Card directly to your PC.

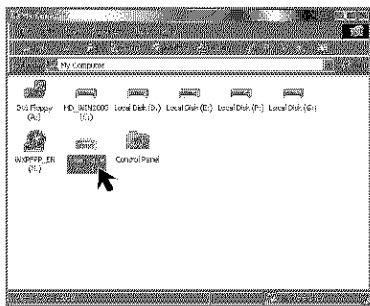

Note

- Please do not change file or folder names on the PC. The images on the Memory Card may not be able to be viewed on the Palmcorder.
- When "ACCESS" is displayed in the EVF or LCD monitor, please do not remove the Memory Card or USB Cable, or turn off the power as data may be damaged.

Before you begin

- Install the Palmcorder USB Device Driver. (p. 57)
- Set POWER to OFF before inserting a recorded Memory Card. (pp. 49, 50)
- Make Palmcorder-PC connections. (pp. 75, 76)
- Turn your PC on. (p. 75)
- Set POWER to M-CARD.

For Windows 98SE/Me/2000 users

- 1** Connect the Palmcorder to your PC using the USB Cable (supplied). (pp. 75, 76)
 - "PLEASE WAIT", "CONNECT WITH PC", and "STORAGE" appears in the EVF or the LCD monitor.
- 2** Open My Computer.
- 3** Click [Removable Disk].
 - You can view images stored on the Memory Card and also save them to your hard disk.

For Windows XP users

- 1** Connect the Palmcorder to your PC using the USB Cable (supplied). (pp. 75, 76)
 - The "Removable Disk" screen is displayed.
 - "PLEASE WAIT", "CONNECT WITH PC", and "STORAGE" appears in the EVF or the LCD monitor.
- 2** Click on [Open folder to view files using Windows Explorer] and then [OK].
 - You can view images stored on the Memory Card and also save them to your hard disk.

Using Palmcorder File Converter

You can convert the JPEG data of your PC into DCF (Design rule for Camera File System) data, and transfer this data to your Palmcorder via USB.

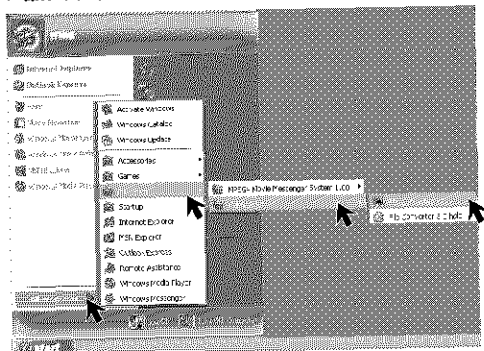

- 1 Set Palmcorder POWER to M-CARD.
- 2 Connect the Palmcorder to your PC using the USB Cable (supplied). (pp. 75, 76)
- 3 Click on "Start," "(All) Programs," "Panasonic," "Palmcorder," then "File Converter 3.0."
- 4 Select and click "To resize the image" or "To convert format for Panasonic Digital Palmcorder."

- **To resize the image:**
The size of images captured with the Palmcorder can be increased or decreased to make them suitable for Internet and e-mail use.
- **To convert format for Panasonic Digital Palmcorder:**
Images can be converted to JPEG format and to file names that can be played back on the Palmcorder.

When selecting "To resize the image"

- 5 Select the size for the image you want to change. Then, click on "File select" and select the file to be converted.

Note

- When User Select is selected, you can specify a size within a range of 2048 x 1536 ~ 64 x 48 pixels.

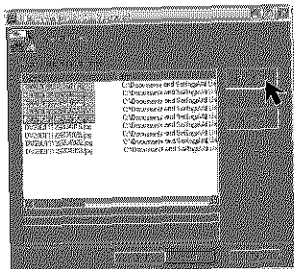
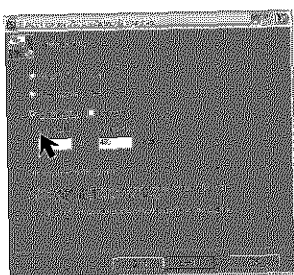
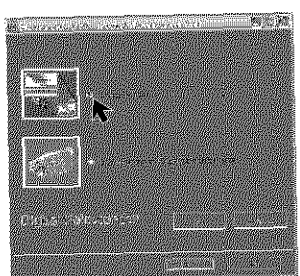

(Continued on next page.)

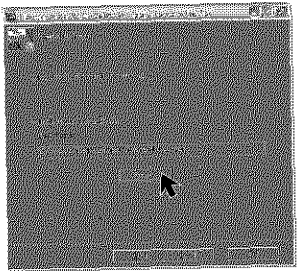

6 Select the folder to which the converted file is to be saved.
• The Conversion results screen is displayed.

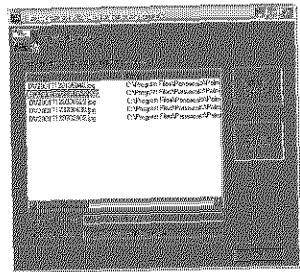

7 Use "Help" for detailed instructions.

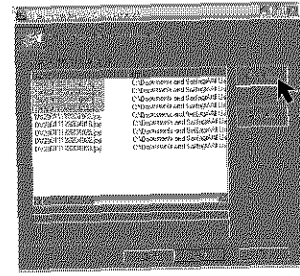

When selecting "To convert format for Panasonic Digital Palmcorder"

5 Select the file to be converted.

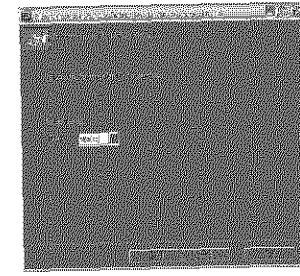

6 Select the drive to which the converted file is to be saved.
• The Conversion results screen is displayed.

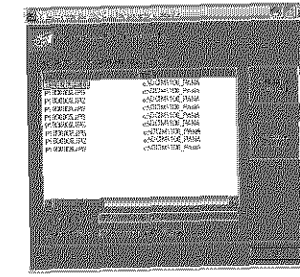

7 Use "Help" for detailed instructions.

Before Using Web Camera* Features

Web Camera*

MSN Messenger and NetMeeting are software that can be linked and used together. Using the Palmcorder and the Internet, you can communicate with others by having picture and sound similar in fashion to a videophone.

Please read this first

- To use the Web Camera feature, Microsoft's Windows Messenger, MSN Messenger Service, and Windows NetMeeting are required.
- For this feature, both parties must have Windows XP.
For this feature, both parties must have Windows 98SE/Me/2000.

- MSN Messenger Service, Windows Messenger and Windows NetMeeting are registered trademarks of America Microsoft Corporation in the United States and other countries.
- Communication quality and assured connectability are dependent upon the congestion conditions of your Internet provider and MSN Messenger Service, etc. This product does not guarantee assured communication quality.

Conditions for Use

- You have direct dial-up connection access to the Internet.
You and the other person(s) are in the same Network (LAN).
- Microsoft MSN Messenger Service 4.5 or later/Windows NetMeeting 3.01 or later is installed.
For Windows XP users, Windows Messenger 4.5 or later is installed.
- It is convenient if the person you want to access is already a registered member of Windows Messenger or MSN Messenger Service.

For Windows XP users

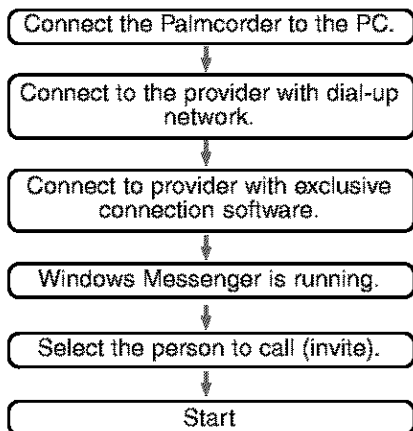

For Windows 98SE/Me/2000 users

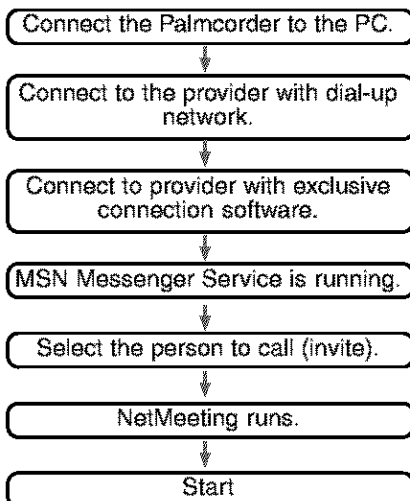

Connection (for Web Camera)

Note

- For Web Camera, do not connect the i.LINK and USB terminals to the Palmcorder at the same time.

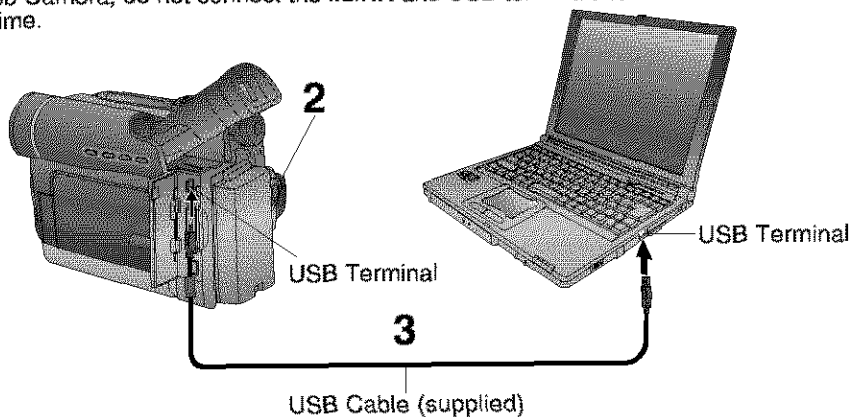

1 Turn on your PC.

2 Set the Palmcorder POWER to CAMERA.

For Windows XP users

3 Connect the Palmcorder to your PC (Windows) using the USB Cable (supplied).

- "Found New Hardware Wizard" is displayed.

The following message **2** is displayed. However, testing by the manufacturer has confirmed functionality of this Palmcorder with Windows XP.

Click [Continue Anyway] and proceed.

Follow the instructions as they appear on your PC screen.

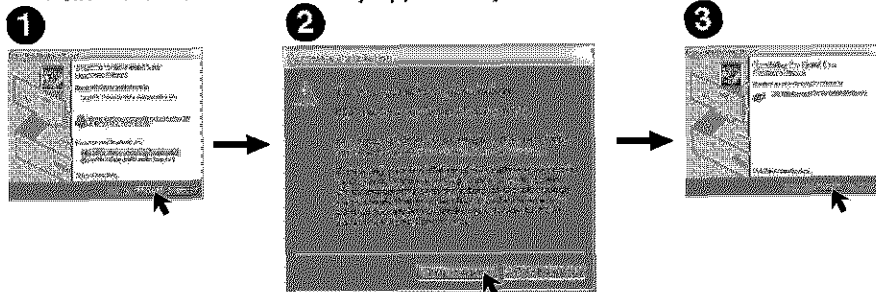

- "CONNECT WITH PC" and "WEBCAM" are displayed in the EVF and LCD monitor.
- Position the Palmcorder so that you are in the picture.
- To confirm if the connection between the Palmcorder and PC is correct, please refer to "Audio and Video Tuning Wizard" on page 84.

Note

- When connecting for the first time using Windows XP, the OS installation CD may be required. Follow the instructions as they appear on your PC screen.
- Do not disconnect the USB Cable while in use. This could be a source of trouble. For more details, please read the respective Help file.
- Close the application, then disconnect the USB Cable.

For Windows 2000 users

- 3** **Connect the Palmcorder to your PC (Windows)** using the USB Cable (supplied).
- "Found New Hardware" is displayed.
 - "CONNECT WITH PC" and "WEBCAM" are displayed in the EVF and LCD monitor.
 - Position the Palmcorder so that you are in the picture.
 - To confirm if the connection between the Palmcorder and PC is correct, please refer to "Audio Tuning Wizard" on page 87.
 - When the Palmcorder and PC (with Windows 2000) are connected via USB, a message, such as the one below, is displayed.
The following message is displayed. However, testing by the manufacturer has confirmed functionality of this Palmcorder with Windows 2000. Click [Yes] and proceed.

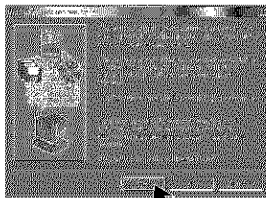

Note

- Do not disconnect the USB Cable while in use. This could be a source of trouble. For more details, please read the respective Help file.
- Close the application, then disconnect the USB Cable.

For Windows 98SE/Me users

- 3** **Connect the Palmcorder to your PC (Windows)** using the USB Cable (supplied).
- "CONNECT WITH PC" and "WEBCAM" are displayed in the EVF and LCD monitor.
 - Position the Palmcorder so that you are in the picture.
 - To confirm if the connection between the Palmcorder and PC is correct, please refer to "Audio Tuning Wizard" on page 87.

Note

- When connecting for the first time using Windows 98SE or Me, the OS installation CD may be required.
- Do not disconnect the USB Cable while in use. This could be a source of trouble. For more details, please read the respective Help file.
- Close the application, then disconnect the USB Cable.

For Windows Messenger (Windows XP only)

When Windows Messenger is newly installed or when running for the first time, the following settings become necessary. For more details, please read the corresponding Help file.

Note

- Once settings are performed, they are not required from the second time the software is run.

Before you begin

- Be sure you have a dial-up connection.
- Referring to pages 81~82, connect the Palmcorder and PC.
Confirm that equipment is connected correctly by running the [Audio and Video Tuning Wizard]. (p. 84)

Caution

- This feature can be used only if both parties have Windows XP.
For Windows Messenger, please refer to the Microsoft Home Page:
<http://www.microsoft.com/>
<http://www.msn.com/>

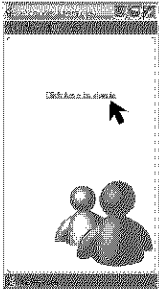
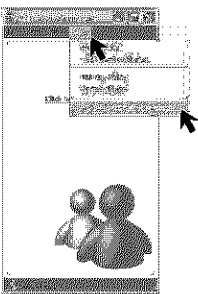
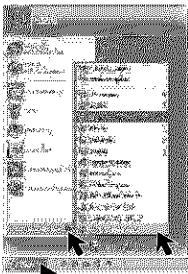

1 Turn on your PC.

2 Click on "Start," "All programs," "Windows Messenger."
• "Windows Messenger" screen is opened.

3 Click on [About Windows Messenger] in the [Help] menu.
• Confirm that your version (Windows Messenger) is 4.5 or later.

Note

- If you have a version older than 4.5, please download the latest version (4.5 or later) from the Microsoft Home Page:
<http://www.microsoft.com/>
<http://www.msn.com/>
- For download and installation instructions, please refer to Help on the Home Page.

4 The first time Windows Messenger is run, etc., the Setup screen is displayed. Click [Click here to sign in]. Please carefully read the contents and then proceed.

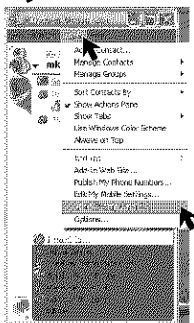
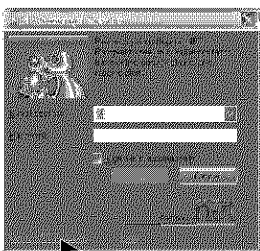

5 Type in your e-mail address and password.

- You'll need to get a hotmail address. If you do not have one, click on [Get a .NET Passport]. Please carefully read the displayed contents and then proceed.

There are times when a Version Upgrade screen will be displayed. However, if you are using Windows Messenger 4.5 or later, there is no need to upgrade.

6 Click on [Audio and Video Tuning Wizard] in the [Tools] menu. Select [USB Audio Device] in the [Microphone] menu.

Note

- You can set the volume for playback or mic volume, etc.
- Also, confirm that the Palmcorder and PC are connected correctly.

1 2 3 4 5 6 7 8 9 10 11 12 13 14 15 16 17 18 19 20 21 22 23 24 25 26 27 28 29 30 31 32 33 34 35 36 37 38 39 40 41 42 43 44 45 46 47 48 49 50 51 52 53 54 55 56 57 58 59 60 61 62 63 64 65 66 67 68 69 70 71 72 73 74 75 76 77 78 79 80 81 82 83 84 85 86 87 88 89 90 91 92 93 94 95 96 97 98 99 100

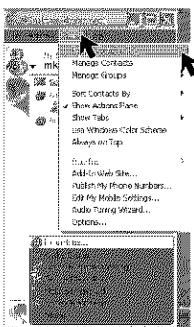

7 Select [File] -> [Add a Contact] to register the person you wish to access in Windows Messenger.

- Please enter the same e-mail address that the other person has registered with Windows Messenger.
- After registering the e-mail address of the person you wish to access, click on [Send E-Mail] and have the person register your e-mail address as well.

You cannot call a person who is not signed-on to Windows Messenger.

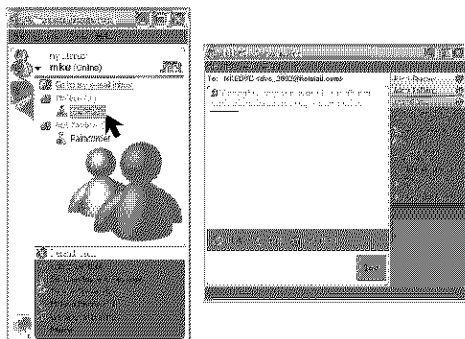

8 The person calling (inviting) side

Double-click a person to call from those currently [on-line].

- "xxx-conversation" screen is displayed.

9 The person calling (inviting) side

Click [Start Camera] in the "xxx-conversation" screen.

- A message inviting the other person is displayed.

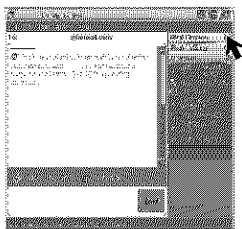

The invited person side

A message asking if the person accepts or declines is displayed.

Click [Accept] on the screen.

- To ignore the invitation, click [Decline].

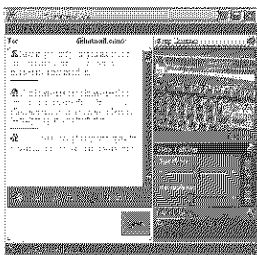

10 At this point you may proceed with a voice/video conversation.

Note

- For other information about Windows Messenger, please refer to Help.

11 When access is finished, close Windows Messenger, then set Palmcorder POWER to OFF. Finally, disconnect the USB Cable.

For MSN Messenger Service and Windows NetMeeting (Windows 98SE/Me/2000)

When MSN Messenger Service is newly installed or when running for the first time, the following settings become necessary. For more details, please read the corresponding Help file.

Note

- Once settings are performed, they are not required from the second time the software is run.

Before you begin

- Be sure you have a dial-up connection.
- Referring to pages 81~82, connect the Palmcorder and PC.
Confirm that equipment is connected correctly by running the [Audio Tuning Wizard]. (p. 87)

Caution

- For MSN Messenger Service and Windows NetMeeting, please refer to the Microsoft Home Page:
<http://www.microsoft.com/>
<http://www.msn.com/>

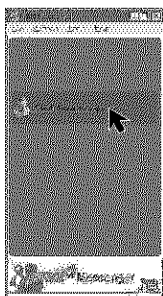

- 1 Turn on your PC.
- 2 Download the latest version MSN Messenger Service (4.5 or later) and Windows NetMeeting (3.01 or later) from the Microsoft Home Page:
<http://www.microsoft.com/>
<http://www.msn.com/>
 - For download instructions, please refer to Help on the Home Page.
- 3 Install the MSN Messenger Service.
 - Follow the instructions on the screen.
- 4 The first time MSN Messenger Service is run, etc., the Setup screen is displayed.
Click [Click here to sign in].
Please carefully read the contents and then proceed.
- 5 Type in your Sign-in name and password.
 - You'll need to get a hotmail address.
If you do not have one, click on [Get one here].
Please carefully read the displayed contents and then proceed.

There are times when a Version Upgrade screen will be displayed. However, if you are using MSN Messenger Service 4.5 or later, there is no need to upgrade.

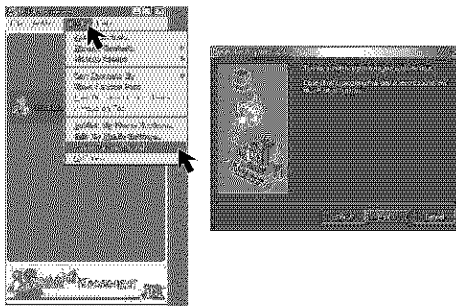

6 Click on [Audio Tuning Wizard] in the [Tools] menu.

- Select [Panasonic USB Microphone]* in the [Recording] menu.

* If you are using Windows 2000, select [USB Audio Device] in the [Recording] menu.

Note

- You can set the volume for playback or mic volume, etc.
- Also, confirm that the Palmcorder and PC are connected correctly.

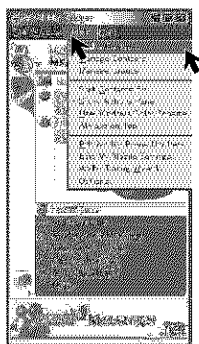

7 Select [Tools] -> [Add a Contact] to register the person you wish to access in MSN Messenger Service.

- Please enter the same e-mail address that the other person has registered with MSN Messenger Service.
- After registering the e-mail address of the person you wish to access, click on [Send E-Mail] and have the person register your e-mail address as well.

You cannot call a person who is not signed-on to MSN Messenger Service.

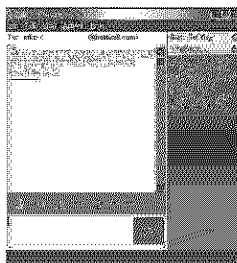
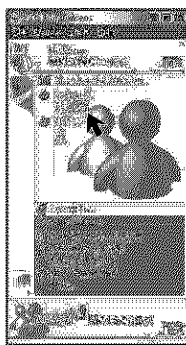

8 The person calling (inviting) side

Double-click a person to call from those currently [on-line].

- "xxxx-conversation" screen is displayed.

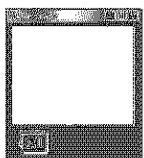
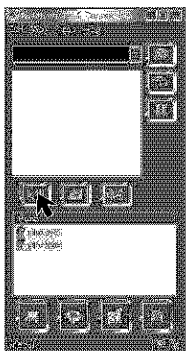
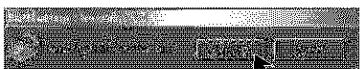
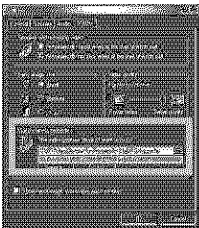
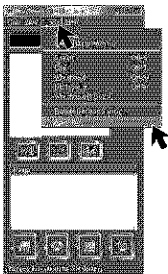
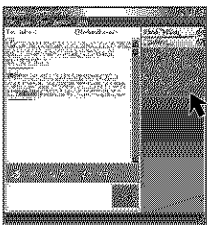

9

The person calling (inviting) side

Click **[Start NetMeeting]** in the "xxx-conversation" screen.

The invited person side

The Instant Message screen appears and a confirmation message is displayed. Click on **[Accept]**.

The **NetMeeting** screen is automatically opened.

Note

The first time Windows NetMeeting is run, etc., the Setup screen is displayed. Please carefully read the contents and then proceed.

The **user information, etc. is input.**

Following the directions, please complete the settings.

10

Click on **[Options]** in the **[Tools]** menu to confirm Video Camera Properties.

- If Video is not recognized in Video Camera Properties, select Control Panel, System, Device Manager, and finally Image Device for confirmation.

11

The invited person side

A message asking if the person accepts or declines is displayed.

Click **[Accept]** on the screen.

- To ignore the invitation, click **[Decline]**.

12

The person calling (inviting) side

"Incoming-Call" screen is displayed.

Click on **[Accept]**.

13

The invited person side

The person calling (inviting) side

The real-time live picture displayed in the video camera is displayed on both yours and the other person's window screen.

Note

- If the picture is not displayed, click  several times on the screen.
- For other information about MSN Messenger Service and Windows NetMeeting, please refer to Help.

14

When access is finished, close MSN Messenger Service and Windows NetMeeting, then set **Palmcorder POWER** to OFF.

Finally, disconnect the USB Cable.

Windows 2000

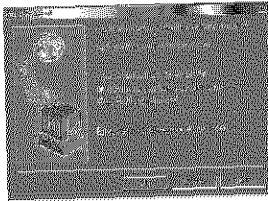
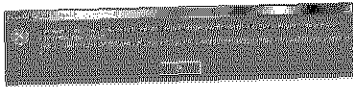

In Windows 2000, startup PHOTOVU/ MPEG4 Movie Messenger™ System. Clicking on [VideoGift] may cause the type of error to occur to the left. If so, please perform the following instructions.

Download and install Media Player (7.1 or later), go to <http://www.microsoft.com/windows/mediaplayer> (current as of Oct. 9, 2002).

- "Windows Media.com: Download" is opened.

Click [Download Now!] on the screen.

- The "File Download" screen is displayed. Then, follow the instructions on the screen.

Transferring Your Images (Macintosh)

You can transfer images from your Palmcorder Memory Card to your Macintosh.

System Requirements (for Built-in SD Drive)

- Mac OS 9.0~9.1
- iMac, iBook or Power Macintosh® G3 with USB port or Power Mac™ G4
- RAM: 64 MB or more
- CD-ROM drive (for installation)
- USB Port
- Mouse or other pointing device

* Even if system requirements are met, there is no guarantee that the included software will work on all personal computers.

Connection

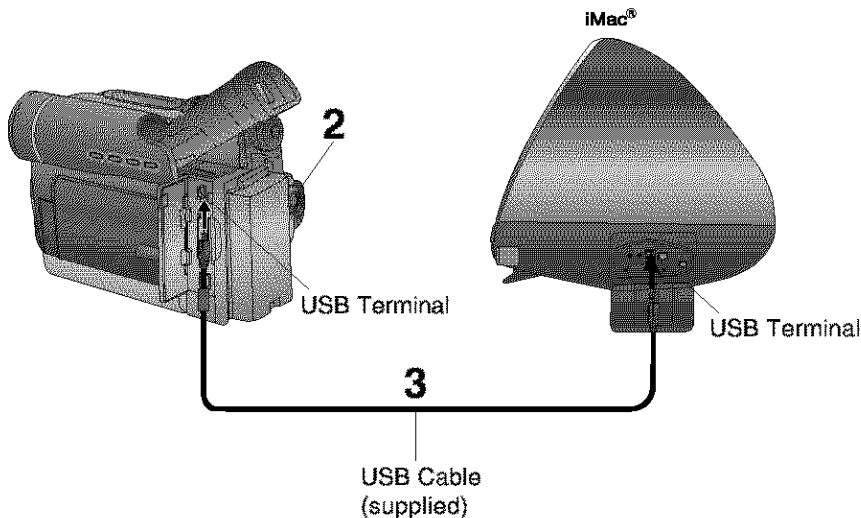

1 Turn on your PC.

2 Set the Palmcorder POWER to M-CARD.

3 Connect the Palmcorder to your Macintosh using the USB Cable (supplied).

Note

- For extended use, it is recommended that you use the AC Adaptor as a power source.

Using Built-in SD Drive

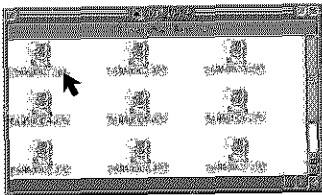
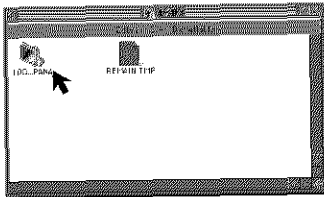
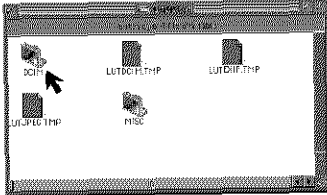

Before you begin

- Set POWER to OFF before inserting a recorded Memory Card. (pp. 49, 50)

- 1** Set the Palmcorder POWER to M-CARD.
- 2** Connect the Palmcorder to your Macintosh using the USB Cable (supplied). (p. 90)
 - "PLEASE WAIT", "CONNECT WITH PC", and "STORAGE" is displayed on the LCD monitor.
- 3** Double click the "Untitled" icon.
 - You can view images stored on the Memory Card and also save them to your hard disk.
- 4** Follow the instructions as they appear on your Macintosh section screen.

Note

- Please do not change file or folder names on the computer. The images on the Memory Card may not be able to be viewed on the Palmcorder.
- When "ACCESS" is displayed in the EVF or LCD monitor, please do not remove the Memory Card or USB Cable, or turn off the power as data may be damaged.

Palmcorder System

Accessory #	Figure	Description	Price
PV-DAC11A		AC Adaptor with AC Cable and DC Cable	\$119.95
CGR-D08A/1B		800mAh / 1 h 30 min, Battery Pack	\$69.95
CGR-D16A/1B		1 600mAh / 3 h, Battery Pack	\$99.95
CGP-D28A/1B		2 800mAh / 5 h, Battery Pack	\$129.95
CGR-D53A/1K		5 300mAh / 9 h, Battery Pack	\$229.95
PV-DDC9		DV Interface Cable (i.LINK) (4-pin to 4-pin)	\$55.00
PV-DRC9		IR Remote Control	\$29.95
PV-H150		Carrying Case	\$49.95
RP-SD064BPPA RP-SD032BPPA RP-SD016BPPA		64 MB SD Memory Card 32 MB SD Memory Card 16 MB SD Memory Card	Call For Pricing
BN-SDCAPE/1B		SD USB Reader/Writer (compatible with MultiMediaCard)	\$79.95
BN-SDABPE/1B		SD PCMCIA Adaptor (compatible with MultiMediaCard)	\$79.95

Palmcorder Accessory Order Form

Please photocopy this form when placing an order.

1. Palmcorder Model # _____

2. Items Ordered

Accessory #	Description	Price Each	Quantity	Total Price
Subtotal				
Your State & Local Sales Tax				
Shipping & Handling				6.95
Total Enclosed				

3. Method of payment (check one)

Check of Money Order enclosed (NO C.O.D. SHIPMENTS)

VISA Credit Card # _____

MasterCard Expiration Date _____

Discover Customer Signature _____

Make Check or Money Order to: PANASONIC ACCESSORIES

(Please do not send cash)

4. Shipping information (UPS delivery requires complete street address)

Ship To:

Mr.

Mrs.

Ms. _____

First

Last

Phone #:

Day () _____

Street Address _____

Night () _____

City

State

Zip

TO OBTAIN ANY OF OUR PALMCORDER ACCESSORIES YOU CAN DO ANY OF THE FOLLOWING:

VISIT YOUR LOCAL PANASONIC DEALER

OR

CALL PANASONIC'S ACCESSORY ORDER LINE AT 1-800-332-5368

[6 AM-5 PM M-F, 6 AM-10:30 AM SAT, PACIFIC TIME]

OR

MAIL THIS ORDER TO: PANASONIC SERVICES COMPANY ACCESSORY ORDER OFFICE
20421 84th Avenue South Kent, WA. 98032

For Your Information

Notice

This product has a fluorescent lamp that contains a small amount of mercury. It also contains lead in some components. Disposal of these materials may be regulated in your community due to environmental considerations. For disposal or recycling information please contact your local authorities, or the Electronics Industries Alliance: <<http://www.eiae.org>.>

About the Memory Card (MultiMediaCard or SD Memory Card)

- Model PV-DV203 can be used with either a MultiMediaCard or a SD Memory Card.
- Both of these exterior Memory Cards (MultiMediaCard and SD Memory Card) are lightweight and removable.
- Both Memory Cards (MultiMediaCard and SD Memory Card) are offered in a variety of memory sizes, so you can purchase a higher capacity Memory Card if desired.

Replacing Clock Battery

The clock battery is pre-installed. Follow the steps below if replacement becomes necessary.

WARNING

Replace battery with Panasonic or Newsun type CR2025 only. Use of another battery may present a risk of fire or explosion.
Caution: battery may explode if mistreated. Dispose of used battery properly. Keep away from children. Do not recharge, disassemble or dispose of in a fire.

Clock Battery

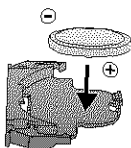
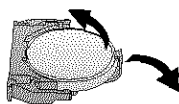
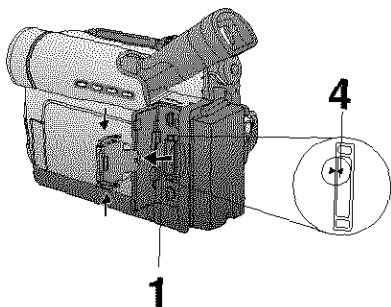

Before you begin

- Set POWER to OFF or disconnect the Palmcorder from a power source.

- 1** While pinching the 2 tabs, pull Battery Tray out.
- 2** Bend middle tab out and remove Battery.
- 3** Snap new Battery (+ mark down) into Battery Tray.
 - Do not reverse the polarity.
- 4** Insert Battery Tray so the triangle marks meet.

Note

- Keep Battery out of children's reach. Swallowing it may be harmful.
- Improper installation, discharge, or missing battery causes "CLOCK BATTERY" to appear.
- Battery life is approximately 5 years.
- Set POWER to OFF or disconnect the Palmcorder from a power source when replacing the clock battery.

Approximate Brightness Values

Your Palmcorder has been designed for normal scene illumination of 150 footcandles (1500 lx). However, the Palmcorder may be used at F1:1.8, if illumination is more than 0.5 footcandles (5 lx).

The table below shows the color temperature for reference.

PALMCORDER SETTINGS	NATURAL LIGHT CONDITIONS	KELVIN COLOR TEMPERATURE	ARTIFICIAL LIGHT SOURCE	COLOR TINT MIXTURE
	<ul style="list-style-type: none"> Fair weather, blue sky 	10,000	<ul style="list-style-type: none"> Color television 	Bluish
	<ul style="list-style-type: none"> Slightly cloudy sky 	8,000	<ul style="list-style-type: none"> Fluorescent lamp (Daylight) Camera flash bulb 	Whitish
	<ul style="list-style-type: none"> Cloudy or rainy sky 	7,000		
	<ul style="list-style-type: none"> Sunlight in clear weather at midday 	6,500		
	<ul style="list-style-type: none"> Average sunlight in clear weather 	6,000	<ul style="list-style-type: none"> Blue lamp for photography 	Whitish
	<ul style="list-style-type: none"> Sunlight 2 hours after sunrise and before sunset 	5,500		
	<ul style="list-style-type: none"> Sunlight 40 min. after sunrise and before sunset 	5,000	<ul style="list-style-type: none"> Fluorescent lamp (White) Normal flash bulb Fluorescent lamp (Off-white) Tungsten lamp for photography 	Whitish
	<ul style="list-style-type: none"> Sunlight 30 min. after sunrise and before sunset 	4,500		
	<ul style="list-style-type: none"> Sunlight 20 min. after sunrise and before sunset 	4,000		
	<ul style="list-style-type: none"> Sunlight 30 min. after sunrise and before sunset 	3,500	<ul style="list-style-type: none"> Halogen lamp Iodine lamp 	Yellowish
<ul style="list-style-type: none"> Sunlight 20 min. after sunrise and before sunset 	3,200			
<ul style="list-style-type: none"> Sunlight 30 min. after sunrise and before sunset 	2,800	<ul style="list-style-type: none"> Tungsten lamp Acetylene lamp Kerosene lamp Candlelight 	Reddish	
<ul style="list-style-type: none"> Sunlight 20 min. after sunrise and before sunset 	2,000			

Power Source:	Palmcorder: 7.2 V DC (Battery) 7.8 V DC (AC Adaptor) AC Adaptor: 110/120/220/240 V AC, 50/60 Hz Battery: Lithium-Ion Type DC 7.2 V
Power Consumption:	Palmcorder : 7.2 V/7.8 V DC 5.5 W AC Adaptor : 18 W 1 W (when not in use.)
Digital Interface	USB/i.LINK (IEEE1394)
Video Signal:	EIA Standard (525 lines, 60 fields) NTSC color signal
Video Recording System:	2 rotary heads, helical scanning system
Audio:	12 bit (32 kHz) 4 tracks 16 bit (48 kHz) 2 tracks
Pick-Up System and Device:	One integral color filter Charge Coupled Device (CCD) 1/6 inch
Lens:	10:1 zoom lens, F1:1.8 with auto iris control Focal length: 2.3 mm - 23 mm Power zoom function Lens filter diameter: 27 mm
Viewfinder:	8.4 mm (0.33 inch) Liquid Crystal Electronic Viewfinder
LCD Monitor:	63.5 mm (2.5 inch) Liquid Crystal Display
Minimum Illumination Required:	10 lx (F1:1.8) 1 footcandle
Memory (Still image)	MultiMediaCard/SD Memory Card 640 x 480 pixels (NORMAL mode) 1280 x 960 pixels (FINE mode)
Image Storage (supplied 8 MB Memory Card)	Approx. 70 images (NORMAL mode) Approx. 30 images (FINE mode)
Image Format	JPEG (Design Rule for Camera File System)
Operating Temperature:	32 °F~104 °F (0 °C~40 °C)
Operating Humidity:	10 %~75 %
Weight:	Palmcorder : 0.46 kg 1.01 lbs. AC Adaptor: 0.16 kg 0.35 lbs.
Dimensions:	Palmcorder : 66 (W) x 87 (H) x 123 (D) mm 2-5/8 (W) x 3-3/8 (H) x 4-7/8 (D) inch AC Adaptor: 70 (W) x 45 (H) x 115 (D) mm 2-3/4 (W) x 1-3/4 (H) x 4-1/2 (D) inch

Weight and dimensions shown are approximate.
Designs and specifications are subject to change without notice.

Cleaning Care for Video Heads

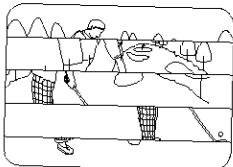

Clogged Video Head

(a) Video Head Cleaning: Normally, your Palmcorder will not require head cleaning. However, it is possible that the heads may become clogged due to dust in the air, playing damaged tapes, long term use, etc. If "NEED HEAD CLEANING" appears for 5 seconds in the EVF or LCD monitor, the heads may require cleaning.

(b) Cleaning the Heads: It is recommended that head cleaning be performed by a qualified service technician. Please contact your nearest Panasonic Servicenter. An alternate solution is to obtain a head cleaning cassette. Please use Panasonic cleaning cassette (AY-DVMCLA). Be sure to follow the cleaning instructions carefully. Excessive use of the head cleaning cassette could shorten video head life. Use this cassette only when a head clogging symptoms occur. Refer servicing to qualified service personnel.

Tape Operations Caution

- When you go from function to function (PLAY, FF, REW etc.), please note that the unit will not accept a new function operation until the previous operation is complete.
- The POWER Button and all function buttons, (PLAY, FF, REW, etc.) are only operational after the tape has been completely loaded.

Lens Hood Area Operation Caution

When the following accessories are attached and the zoom is set to maximum wide angle, the four corners of the screen may appear darker:

- Wide or Telephoto conversion lens (optional).
- A filter (optional), etc. and then the lens hood.
- Two filters (optional).

Self Diagnostic System

If any of the following numbers appear on-screen, the camcorder may need service. Do not remove the battery (if attached) and write down the displayed number on page 101. Then, take the camcorder to a servicenter for repair.







Error No.	Description
U11	Card Error
U12	Card Error
U14	Card/Camcorder Dialogue Error
U15	Card Access Error
U16	Card Access Error
U30	Error other than above

If you have a problem with your Palmcorder, it may be something you can correct yourself. Check the list below for symptoms and corrections.

Symptom	Correction
No picture in the EVF or LCD Monitor...	<ul style="list-style-type: none">• Make sure the Power Source is connected. (pp. 15, 16)• Make sure the POWER switch is set to VCR or CAMERA. (pp. 19, 32)• Check the Dew Indicator. (p. 100)• Make sure the Battery is fully charged. (p. 15)• Make sure all necessary cables are connected correctly and firmly. (p. 16)• Make sure the Lens Cap is removed. (p. 19)
Video cassette cannot be inserted...	<ul style="list-style-type: none">• Make sure the Power Source is connected. (pp. 15, 16)• Insert the cassette record tab up, window side facing out. (p. 12)
Video cassette cannot be removed...	<ul style="list-style-type: none">• Make sure the Power source is connected. (pp. 15, 16)
No operation starts when operation buttons are pressed...	<ul style="list-style-type: none">• Check the Dew Indicator. (p. 100)
Recording cannot be done...	<ul style="list-style-type: none">• Make sure the record tab is closed. (p. 6)• Check the Battery Indication. (p. 113)
Auto Focus does not operate...	<ul style="list-style-type: none">• Make sure FOCUS is set to AUTO. (p. 29)• Make sure the unit is ON and set to CAMERA mode. (p. 19)
Sound from microphone cannot be monitored...	<ul style="list-style-type: none">• Make sure the unit is set to REC or REC/PAUSE mode. (p. 19)
Sound cannot be heard...	<ul style="list-style-type: none">• Make sure the Audio on the VCR MENU is set to ST1. (pp. 46, 110)

On-Screen Displays (OSD)

The following warning displays appear in the EVF and the LCD monitor.

Indications	Condition
 TAPE NOT INSERTED	If the Palmcorder is in CAMERA mode without a cassette inserted, "TAPE NOT INSERTED" will flash and "TAPE NOT INSERTED" will appear for 5 seconds. Recording will not start.
 CHECK REC TAB	If the Palmcorder is in CAMERA mode or Audio dub mode with the cassette sliding record tab opened, "CHECK REC TAB" will flash and "CHECK REC TAB" will appear for 5 seconds. Recording will not start.
 CANNOT REC	When Audio dub is performed and the recording is other than NTSC format, "CANNOT REC" will flash and "CANNOT REC" will appear for 5 seconds.
 TAPE END	When the tape is about to end in REC mode, "TAPE END" will flash and "TAPE END" will appear for 5 seconds.
INCOMPATIBLE TAPE	When an incompatible tape is detected, "INCOMPATIBLE TAPE" will appear for 5 seconds.
NEED HEAD CLEANING	If the video heads require cleaning, "NEED HEAD CLEANING" will appear for 5 seconds.
REMOTE	When the Palmcorder and remote are not set to the same mode (VCR1 or VCR2), "CHECK REMOTE MODE (REMOTE)" appears for 5 seconds. It also appears when the Palmcorder is first turned on.
CANNOT REC LP-MODE	When an AUDIO DUB is attempted on a pre-recorded LP tape, "CANNOT REC LP-MODE" will appear for 5 seconds.
 DEW DETECTED	If excessive moisture condenses in the unit, "WARNING" will flash, "DEW DETECTED" will appear, and the Palmcorder will automatically turn OFF in 15 seconds. In this case, wait until the indicator no longer flashes when your Palmcorder is turned ON again.
 LOW BATTERY	When a battery recharge is necessary, "WARNING" will flash, "LOW BATTERY" will appear, and the Palmcorder will automatically turn OFF in 15 seconds. (p. 113)
CLOCK BATTERY	When the Clock Battery is discharged, "CLOCK BATTERY" will appear. To replace the Clock Battery, set POWER to OFF or disconnect the Palmcorder from a power source.
INCOMPATIBLE DATA	If you play a tape recorded in a format other than NTSC or you try to copy copy-protected data, "INCOMPATIBLE DATA" will appear.
NO CARD	Card is not inserted.
NO SPACE LEFT	When a still image is transferred from a tape to an already full Memory Card, or when setting is DPOF, "NO SPACE LEFT" appears.

Indications	Condition
DISCONNECT DV CABLE	If the Palmcorder is in Photo Title (CAMERA mode) and the DV Interface Cable (i.LINK) is connected, "DISCONNECT DV CABLE" appears. In this case, remove the DV Interface Cable (i.LINK) from the Palmcorder.
DISCONNECT USB CABLE	If you are attempting to record from a Cassette by pressing PHOTO SHOT, when the USB Cable is connected, "DISCONNECT USB CABLE" appears. In this case, remove the USB Cable from the Palmcorder.
PICTURE	When making DV connection at the time of M-CARD mode. (Blink during 3 seconds.)
WEBCAM	When making DV connection at the time of Web Camera mode. (Blink during 3 seconds.)
STORAGE	When making DV connection at the time of USB Device Driver/SD Drive mode. (Blink during 3 seconds.)
WRITE PROTECTED	In M-CARD mode, this display appears if the SD Memory Card Lock Switch is in the Lock position.

Request for Service Notice

Please photocopy this form when making a request for service notice.

Request for Service Notice:

In the unlikely event this product needs service.

- Please include your **proof of purchase**. (Failure to do so will delay your repair.)
- To further speed your repair, please provide an explanation of what is wrong with the unit and any symptom it is exhibiting.

Mail this completed form and your Proof of Purchase along with your unit to:
Panasonic Services Company
1705 N. Randall Road
Elgin, IL. 60123-7847
Attn: Camcorder Repair

Please write the displayed Self Diagnostic number here.
(p. 98)

PANASONIC CONSUMER ELECTRONICS COMPANY,
DIVISION OF MATSUSHITA ELECTRIC
CORPORATION OF AMERICA
One Panasonic Way Secaucus, New Jersey 07094

PANASONIC SALES COMPANY, DIVISION OF MATSUSHITA
ELECTRIC OF PUERTO RICO, INC.,
AVE. 65 de Infantería, Km. 9.5 San Gabriel Industrial Park,
Carolina, Puerto Rico 00985

Panasonic/Quasar Video Products Limited Warranty

Limited Warranty Coverage

If your product does not work properly because of a defect in materials or workmanship, Panasonic Consumer Electronics Company or Panasonic Sales Company (collectively referred to as "the warrantor") will, for the length of the period indicated on the chart below, which starts with the date of original purchase ("warranty period"), at its option either (a) repair your product with new or refurbished parts, or (b) replace it with a new or a refurbished product. The decision to repair or replace will be made by the warrantor.

Product	Parts	Labor	Service	Contact Number
Camcorder	One (1) Year (except CCD Image Sensor) CCD Image Sensor - 6 (Six) Months	Ninety (90) Days Ninety (90) Days	Carry-In or Mail-In	1-800-211-PANA(7262)
DVD/VCR Deck, A/V Mixer	One (1) Year	Ninety (90) Days	Carry-In or Mail-In	1-800-211-PANA(7262)
TV/VCR, TV/DVD, TV/DVD/VCR Combination	One (1) Year (except CRT) CRT - Two (2) Years	Ninety (90) Days Ninety (90) Days	Carry-In: 21" CRT and Smaller In-Home or Carry-In: 22" CRT and Larger	1-800-211-PANA(7262)
TV/HDR Combination	One (1) Year (except CRT) CRT - Two (2) Years	Ninety (90) Days Ninety (90) Days	In-Home or Carry-In	1-888-843-9788
Rechargeable Batteries (in exchange for defective item)	Ten (10) Days	Not Applicable	Carry-In or Mail-In	1-800-211-PANA(7262)
Tape (in exchange for defective item)	Five (5) Days	Not Applicable	Carry-In or Mail-In	1-800-211-PANA(7262)
Memory Cards (in exchange for defective item)	Ninety (90) Days	Not Applicable	Carry-In or Mail-In	1-800-211-PANA(7262)

During the "Labor" warranty period there will be no charge for labor. During the "Parts" warranty period, there will be no charge for parts. You must carry-in or mail-in your product or arrange for in-home service, as applicable, during the warranty period. If non-rechargeable batteries are included, they are not warranted. This warranty only applies to products purchased and serviced in the United States or Puerto Rico. This warranty is extended only to the original purchaser of a new product which was not sold "as is". A purchase receipt or other proof of the original purchase date is required for warranty service.

Carry-In, Mail-in or In-Home Service

For Carry-In, Mail-In or In-Home Service (as applicable) in the United States call toll free contact number listed above or visit Panasonic Web Site: <http://www.panasonic.com>

For assistance in Puerto Rico call Panasonic Sales Company (787)-750-4300 or fax (787)-768-2910.

In-Home service, if applicable, requires clear, complete and easy access to the product by the authorized servicer and does not include removal or re-installation of an installed product. It is possible that certain in-home repairs will not be completed in-home, but will require that the product, or parts of the product, be removed for shop diagnosis and/or repair and then returned.

Limited Warranty Limits And Exclusions

This warranty ONLY COVERS failures due to defects in materials or workmanship, and DOES NOT COVER normal wear and tear or cosmetic damage, nor does it cover markings or retained images on the picture tube resulting from viewing fixed images (including, among other things, letterbox pictures on standard 4:3 screen TV's, or non-expanded standard 4:3 pictures on wide screen TV's, or onscreen data in a stationary and fixed location). The warranty ALSO DOES NOT COVER damages which occurred in shipment, or failures which are caused by products not supplied by the warrantor, or failures which result from accidents, misuse, abuse, neglect, mishandling, misapplication, alteration, faulty installation, set-up adjustments, misadjustment of consumer controls, improper maintenance, power line surge, lightning damage, modification, or commercial use (such as in a hotel, office, restaurant, or other business), rental use of the product, service by anyone other than a Factory Servicenter or other Authorized Servicer, or damage that is attributable to acts of God.

THERE ARE NO EXPRESS WARRANTIES EXCEPT AS LISTED UNDER "LIMITED WARRANTY COVERAGE". THE WARRANTOR IS NOT LIABLE FOR INCIDENTAL OR CONSEQUENTIAL DAMAGES RESULTING FROM THE USE OF THIS PRODUCT, OR ARISING OUT OF ANY BREACH OF THIS WARRANTY. (As examples, this excludes damages for lost time, cost of having someone remove or re-install an installed unit if applicable, or travel to and from the servicer, loss of media or images, data or other memory or recorded content. The items listed are not exclusive, but are for illustration only.)

ALL EXPRESS AND IMPLIED WARRANTIES, INCLUDING THE WARRANTY OF MERCHANTABILITY, ARE LIMITED TO THE PERIOD OF THE LIMITED WARRANTY.

Some states do not allow the exclusion or limitation of incidental or consequential damages, or limitations on how long an implied warranty lasts, so the exclusions may not apply to you.

This warranty gives you specific legal rights and you may also have other rights which vary from state to state. If a problem with this product develops during or after the warranty period, you may contact your dealer or Servicenter. If the problem is not handled to your satisfaction, then write to the warrantor's Consumer Affairs Department at the addresses listed for the warrantor.

PARTS AND SERVICE (INCLUDING COST OF AN IN-HOME SERVICE CALL, WHERE APPLICABLE) WHICH ARE NOT COVERED BY THIS LIMITED WARRANTY ARE YOUR RESPONSIBILITY.

For Product Information, Operating Assistance, Literature Request, Dealer Locations, and all Customer Service inquiries please contact:
1-800-211-PANA (7262), Monday-Friday 9 am-9 pm; Saturday-Sunday 9 am-7 pm, EST.
or send e-mail : consumerproducts@panasonic.com
For hearing or speech impaired TTY users, TTY: 1-877-833-8855

Web Site: <http://www.panasonic.com>
You can purchase parts, accessories or locate your nearest servicer by visiting our Web Site.

Accessory Purchases:

1-800-332-5368 (Customer Orders Only)
For hearing or speech impaired TTY users, TTY: 1-866-605-1277
Panasonic Services Company 20421 84th Avenue South, Kent, WA 98032
(Monday-Friday 6 am-5 pm; Saturday 6 am-10:30 am, PST)
(Visa, MasterCard, Discover Card, American Express, Check)

Product Repairs

Centralized Factory Servicer

MAIL TO :

Panasonic Services Company
1705 N. Randall Road,
Elgin, IL 60123-7847
Attention: Camcorder Repair

Please carefully pack and ship, prepaid and insured, to the Elgin Centralized Factory Servicer.
Customer's in Puerto Rico, please ship or carry in to location below ("Service in Puerto Rico").

Service in Puerto Rico

Matsushita Electric of Puerto Rico, Inc. Panasonic Sales Company/ Factory Servicer:
Ave. 65 de Infanteria. Km. 9.5, San Gabriel Industrial Park, Carolina, Puerto Rico 00985
Phone (787) 750-4300 Fax (787) 768-2910

As of August 2002

Precauciones para su seguridad

ADVERTENCIA: PARA EVITAR INCENDIOS Y DESCARGAS ELÉCTRICAS, NO EXPONGA ESTE EQUIPO A LA LLUVIA NI A LA HUMEDAD.

Su ^{Mini} **DX** Palmcorder está diseñada para grabar y reproducir en el modo de Reproducción Estándar (SP) y modo Largo (LP).

Se recomienda el uso sólo de cintas de cassette que hayan sido probadas e inspeccionadas para su uso en aparatos VCR con la marca ^{Mini} **DX**.

 PRECAUCIÓN RIESGO DE DESCARGA ELÉCTRICA NO ABRIR 		Este símbolo tiene por finalidad alertar al usuario acerca de la presencia de tensión sin aislación en el interior del producto, que puede tener la intensidad suficiente como para causar descargas eléctricas. Por lo tanto, hacer contacto con cualquier pieza en el interior de la unidad es peligroso.
PRECAUCIÓN: PARA REDUCIR EL RIESGO DE DESCARGA ELÉCTRICA, NO quite LA CUBIERTA (O PARTE POSTERIOR). EL APARATO NO TIENE EN SU INTERIOR PIEZAS QUE PUEDAN SER REPARADAS POR EL USUARIO. SOLICITE TODA REPARACIÓN A PERSONAL DE SERVICIO CUALIFICADO.		Este símbolo tiene por finalidad alertar al usuario de la presencia de importantes instrucciones de operación y mantenimiento en la literatura incluida con la unidad. Por lo tanto, lea detenidamente la literatura incluida para evitar problemas.

La etiqueta de régimen está pegada en la base de la cubierta del cargador.

Este dispositivo cumple con la parte 15 de las Reglas del FCC. El funcionamiento está sujeto a las dos siguientes condiciones: (1) Este dispositivo puede no causar interferencias perjudiciales, y (2) este dispositivo debe aceptar cualquier interferencia recibida, incluyendo interferencias que pueden causar un funcionamiento no deseado.

Nota: Este equipo ha sido puesto a prueba y se encontró que cumple con la Parte 15 de las reglas del FCC. Estos límites están diseñados para proveer una protección razonable contra interferencias cuando se opera en un ambiente residencial.

Si este equipo causa interferencias en la recepción de radio o televisión, lo cual se puede comprobar al apagar y encender el equipo, utilice el equipo en otra ubicación y/o utilice un tomacorriente diferente al que está utilizando el receptor. Si es necesario, consulte con el distribuidor o un técnico experto de radio/TV para solicitar ayuda. Puede encontrar útil el folleto 'Información sobre las interferencias' disponible en las oficinas regionales del FCC local.

Advertencia del FCC:

Para asegurar la conformidad continua del FCC, utilice solamente el cable de interfaz blindado cuando conecte una cámara de video digital a una computadora de acuerdo con las instrucciones incluidas aquí. También, cualquier cambio sin autorización o modificaciones a este equipo anularían la autoridad del usuario para operarlo.

Inserte de la batería

Antes de comenzar

- Cargue la batería. (Página 15.)

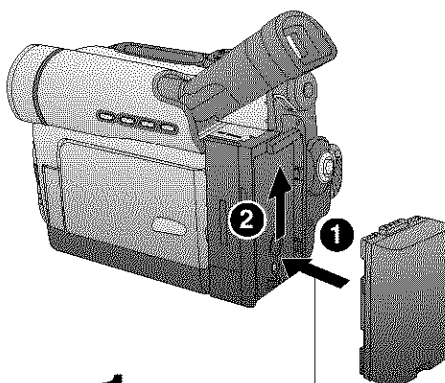

- 1** Coloque la batería y deslícela hacia arriba hasta que se quede bloqueada con un clic.

Inserte el Cassette

Esta videocámara contiene un sistema de ejecución fácil del cassette. Por eso, es fácil de introducir o sacar el cassette aunque esté montado sobre un trípode. (Página 7.)

- 2** Deslice el interruptor de expulsión de cinta (TAPE EJECT) para abrir la tapa del compartimento del cassette.

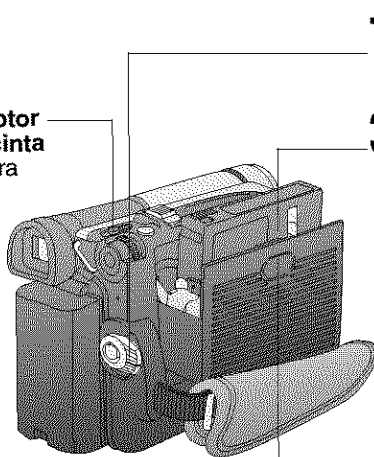

- 1** Ajuste el interruptor de alimentación (POWER) a la posición VCR o CAMERA.
- 3** Introduzca un cassette con la parte de la ventana hacia arriba.
 - Asegúrese de que la lengüeta de grabación esté cerrada. (Página 6.)
- 4** Presione la marca PUSH CLOSE (EMPUJAR PARA CERRAR) para cerrar la tapa del compartimento del cassette.

Grabación con la cámara

Cuando el monitor LCD se encuentra totalmente abierto, el visor se DESACTIVA automáticamente.

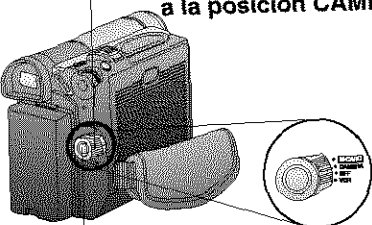
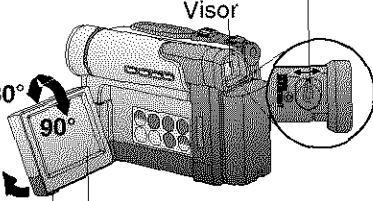
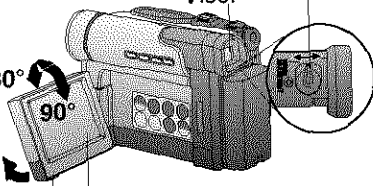
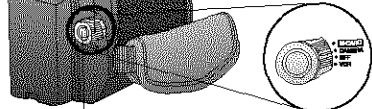
- **1** Ajuste el interruptor de alimentación (POWER) a la posición CAMERA.
- **2** Ajuste el control de ajuste de visión según lo desee.
- **3** Utilice la lengüeta OPEN para desbloquear el monitor LCD. Balancée abriéndolo completamente y ajuste el ángulo.
- **4** Presione el botón de grabación/pausa (REC/PAUSE) para iniciar la grabación. Vuelva a pulsar el botón de grabación/pausa (REC/PAUSE) para hacer una pausa en la grabación.

Para ver la reproducción en el LCD (pantalla de visualización de cristal líquido)

Cuando el monitor LCD se encuentra totalmente abierto, el visor se DESACTIVA automáticamente.

Antes de comenzar

- Cargue la batería. (Página 15.)

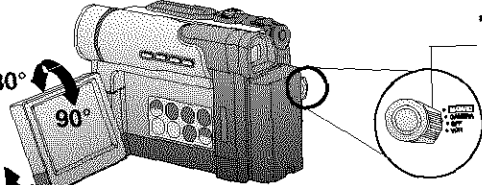
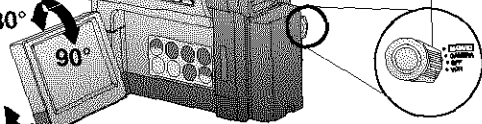
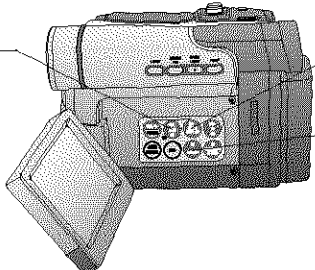
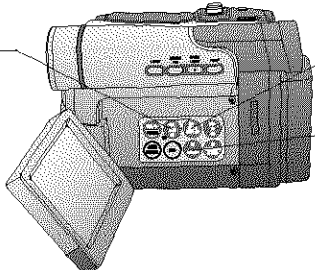
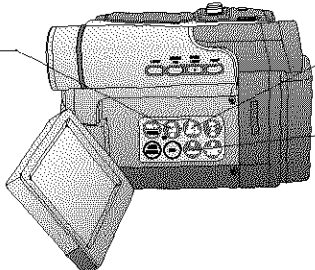
- **1** Ajuste el interruptor de alimentación (POWER) a la posición VCR.
- **2** Utilice la lengüeta OPEN para desbloquear el monitor LCD. Balancée abriéndolo completamente y ajuste el ángulo.
- **3** Presione el botón de rebobinado ◀ (REW) para rebobinar la cinta.
- **4** Presione el botón de reproducción ▶ (PLAY) para reproducir la cinta.
- **5** Presione el botón de parada ■ (STOP) para detener la reproducción.

Introducir la Tarjeta de memoria*

Antes de comenzar

- Cargue la batería. (Página 15.)

*Tarjeta de Memoria: Tarjeta MultiMedia o Tarjeta de Memoria SD (Página 94.)

- Asegúrese de introducir la Tarjeta de memoria antes de utilizar la tarjeta PhotoShot. (Página 49.)

A continuación se indican una lista de Tarjetas de Memoria soportadas por esta unidad.

Memory Card	Capacity
Tarjeta de memoria SD (RP-SD008BMK0)	8 MB
Tarjeta MultiMedia (Marca de fábrica SanDisk)	8 MB, 16 MB
Tarjeta de Memoria SD (opcional) (Página 92.)	16 MB, 32 MB, 64 MB

Botón para la protección de copia de la tarjeta de memoria SD



La tarjeta de memoria SD tiene un botón para la protección de copia. Deslice el botón hacia la dirección de LOCK para prevenir una copia o cambio de la estructura de la tarjeta.

Botón para la protección de copia

- 2** Abra la puerta de la ranura de la tarjeta.

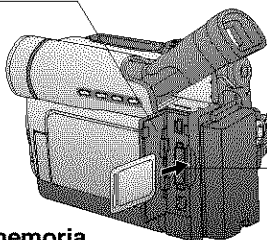

- 1** Ajuste el interruptor de alimentación (POWER) a la posición OFF.

- 3** Introduzca la tarjeta de memoria hasta que se coloque en su sitio con un clic.

- 4** Cierre la puerta de la ranura de la tarjeta.

Para quitar la tarjeta de memoria...

Presione aquí para quitar la tarjeta.

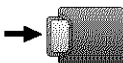

Al insertar la tarjeta de memoria

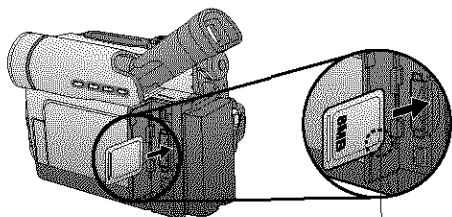

esquina recortada

Nota

- Al insertar la tarjeta de memoria, insertela con la esquina recortada hacia abajo tal como se indica en la figura anterior.

Camera Mode Menu Screen

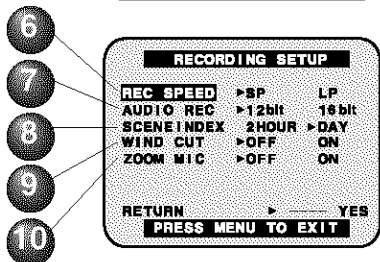
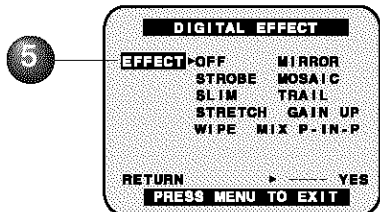
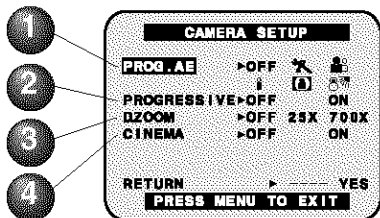

- 1 **PROG. AE** (p. 25)
To select one of the 5 Program AE modes. Setting to OFF cancels the previously selected Program AE mode.
- 2 **PROGRESSIVE** (p. 21)
When set to ON, still pictures taken with PhotoShot are recorded with a higher resolution than with normal PhotoShot.

- 3 **D. ZOOM** (p. 40)
To select 25X (from 10X to 25X) or 700X (from 10X to 700X). Setting to OFF cancels the previously selected digital zoom.
- 4 **CINEMA** (p. 24)
When set to ON, you can record a picture compatible with a wide-screen TV equipped with an S2 picture terminal.
- 5 **EFFECT** (p. 43)
To select one of the 10 digital functions. Setting to OFF cancels the previously selected digital function.
- 6 **REC SPEED** (pp. 6, 19)
SP: Normal recording speed mode.
LP: Recording time is 1.5 times as long as in the SP mode. For example, 120 minutes of recording is possible on a 80 minute tape.
- 7 **AUDIO REC** (p. 45)
12 bit: The sound is recorded in the 12 bit/32 kHz mode.
16 bit: The sound is recorded in the 16 bit/48 kHz high-quality mode.
- 8 **SCENEINDEX**
DAY: An index signal is recorded when recording is restarted after the date has changed since the last recording.
2 HOUR: An index signal is recorded when recording is restarted after a lapse of more than 2 hours.
- 9 **WIND CUT** (p. 31)
To reduce sound distortion caused by wind hitting the microphone.
- 10 **ZOOM MIC** (p. 22)
When set to ON, the microphone's directional angle and sensitivity vary according to the zoom operation.

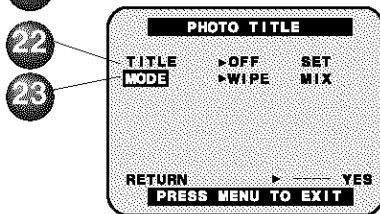
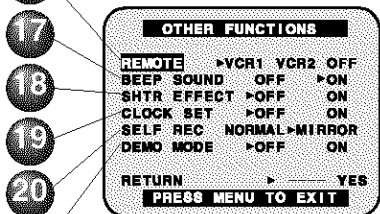
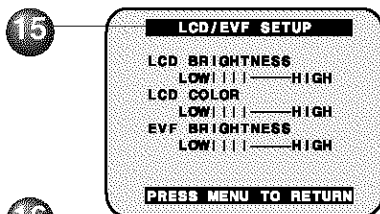
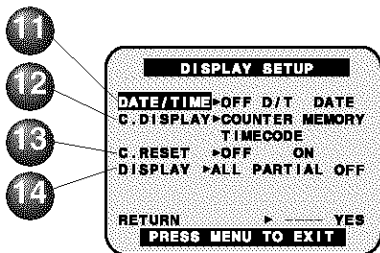

- 11 **DATE/TIME** (p. 113)
The date and time can be set and displayed on the screen.
- 12 **C. DISPLAY** (p. 114)
To select the desired type of counter indication displayed on the LCD Monitor or in the viewfinder.
- 13 **C. RESET** (p. 114)
Setting to ON resets the counter to zero.

- 14 **DISPLAY** (p. 114)
To select the desired type of display changes to all function display, Partial display, and Minimum display.
- 15 **LCD/EVF SETUP** (p. 20)
Setting to ON displays the menu for adjusting the LCD brightness, color level, and the EVF brightness.
- 16 **REMOTE** (p. 10)
VCR1: To receive signals from the Remote Control, set to VCR1.
VCR2: To receive signals from the Remote Control, set to VCR2.
OFF: To prevent reception of signals from the Remote Control.

- 17 **BEEP SOUND**
Set to ON to hear beep when starting and stopping camera recording or when unusual conditions occur. To cancel the beep, set to OFF.

Palmcorder will beep:
Once when you start recording
Twice when you stop recording
Repeatedly when warning of unusual conditions. (pp. 100, 101)

- 18 **SHTR EFFECT** (pp. 21, 49)
When set to ON, still pictures taken in the PhotoShot mode are recorded with a visual shutter effect and click sound.
- 19 **CLOCK SET** (p. 17)
When set to ON, the date and time can be set on the screen.
- 20 **SELF REC** (p. 23)
NORMAL: During self-recording, the picture on the LCD Monitor is the same as it will be recorded.
MIRROR: During self-recording, the picture on the LCD Monitor is horizontally reversed.

- 21 **DEMO MODE** (p. 11)
When set to ON, Self Demo starts.
- 22 **TITLE** (p. 27)
Photo Title is recorded.
- 23 **MODE** (p. 27)
To select one of the 2 Photo Title modes.

VCR Mode Menu Screen

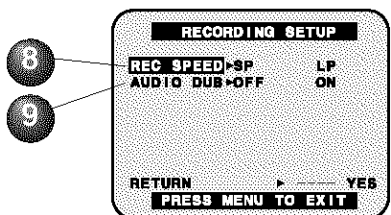
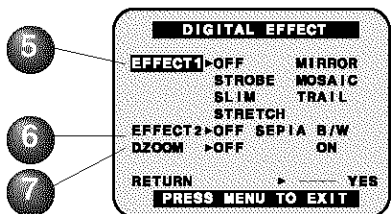
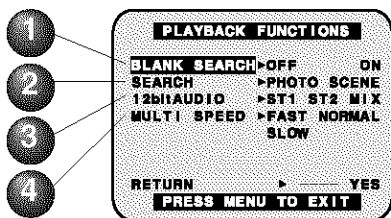

- 1 **BLANK SEARCH** (p. 33)
Select ON to go directly to a blank portion of the tape.
- 2 **SEARCH** (p. 37)
To select the desired Index Search function.
PHOTO: To search for Photo shot pictures.
SCENE: To search for scenes marked with Index signal.
- 3 **12bit AUDIO** (p. 46)
To select the desired audio playback mode after performing audio dubbing in the 12 bit mode (SP mode only).
ST1 : The original sound alone is played back.
ST2 : The dubbed sound alone is played back.
MIX : The original sound and the dubbed sound are played back together.
- 4 **MULTI SPEED** (p. 38)
In Strobe Multi mode, used to select the interval at which a succession of still screens are captured from the playback picture.
FAST : Every 0.3 seconds
NORMAL : Every 0.6 seconds
SLOW : Every 1.0 seconds
- 5 **EFFECT1** (p. 43)
To select one of the 6 digital functions. Setting to OFF cancels the previously selected digital function.
- 6 **EFFECT2** (p. 43)
To select one of the 2 digital picture effects for playback. Setting to OFF cancels the previously selected digital effect.
- 7 **D. ZOOM** (p. 41)
Set to ON to double the size of a playback image. Setting to OFF cancels the previously selected digital zoom.
- 8 **REC SPEED** (p. 6)
SP: Normal recording speed mode.
LP: Recording time is 1.5 times as long as in the SP mode. For example, 120 minutes of recording is possible on an 80 minute tape.
- 9 **AUDIO DUB** (p. 45)
Set to AUDIO DUB "ON" in the Menu OSD to use the Audio Dub feature.

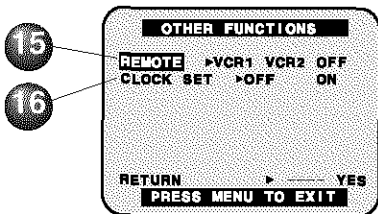
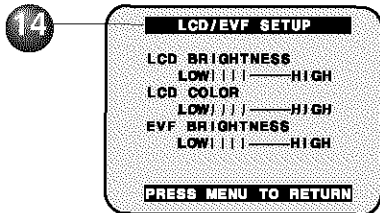
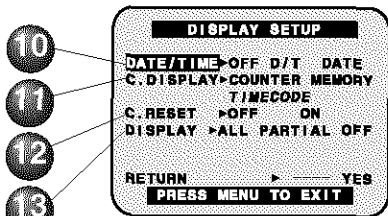

- 10** **DATE/TIME** (p. 113)
The date and time can be set and displayed on the screen.
- 11** **C. DISPLAY** (p. 114)
To select the desired type of counter indication displayed on the LCD Monitor or in the viewfinder.
- 12** **C. RESET** (p. 114)
Setting to ON resets the counter to zero.
- 13** **DISPLAY** (p. 114)
To select the desired type of display changes to all function display, Partial display, and Minimum display.
- 14** **LCD/EVF SETUP** (p. 20)
Setting to ON displays the menu for adjusting the LCD brightness, color level, and the EVF brightness.
- 15** **REMOTE** (p. 10)
 - VCR1** : To receive signals from the Remote Control, set to VCR1.
 - VCR2** : To receive signals from the Remote Control, set to VCR2.
 - OFF** : To prevent reception of signals from the Remote Control.
- 16** **CLOCK SET** (p. 17)
When set to ON, the date and time can be set on the screen.

M-CARD Mode Menu Screen

[Photo Rec Mode Menu Screen]

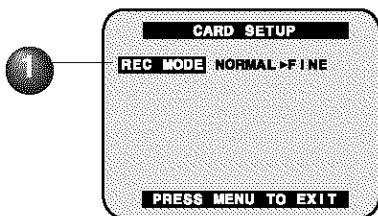

1 REC MODE (p. 49)
To select Photo Rec Mode.

[Photo Play Mode Menu Screen]

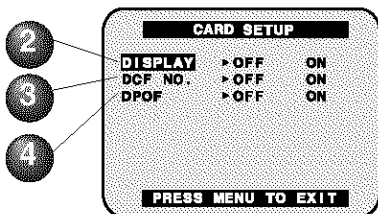

2 DISPLAY (p. 116)
Select to OFF to cancel all Displays on the screen.

3 DCF NO. (pp. 51, 116)
Select to OFF to cancel DCF (Design rule for Camera File system) No. on the screen.

4 DPOF (pp. 55, 116)
When set to ON, information of the image to be printed and the number of prints desired (DPOF data) is written to the Memory Card.

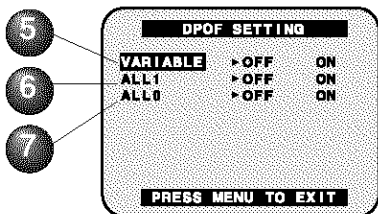

5 VARIABLE (p. 55)
When set to ON, you can select images recorded on the Memory Card and set the number of prints desired.

6 ALL1 (p. 55)
When set to ON, the number of prints recorded on the Memory Card is collectively set to 1.

7 ALL0 (p. 55)
When set to ON, the currently set number of prints is set to 0.

Here are some of the basic indications which will appear on the Palmcorder EVF and LCD Monitor. Only Date and Time indications will be recorded onto the tape.

CAMERA/VCR Mode

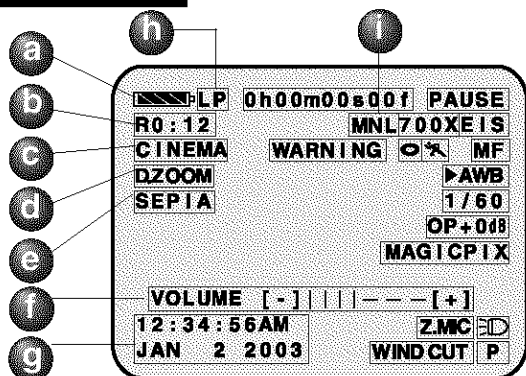

a Battery Remaining

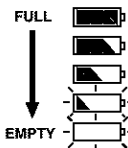

b Tape Remaining (AY-DVM30EJ) (AY-DVM60EJ)

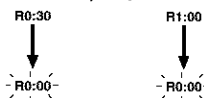

• It will take several seconds for the tape remaining indicator to operate after the tape starts moving.

c CINEMA Indication (Menu OSD: p. 108)

d Digital Zoom and other Digital Functions (Menu OSD: p. 108)

This display appears when the digital zoom function has been activated.

e Playback Effect (Menu OSD: p. 110)

This display appears when SEPIA or B/W is selected in VCR menu.

f Volume Display (p. 33)

The volume bar appears when the volume of the built-in speaker is being adjusted.

g Date and Time Indication (Menu OSD: pp. 109, 111)

As shown below, the date and time indication changes each time DATE/TIME is selected from the Palmcorder's MENU (Menu OSD: pp. 109, 111) or the DATE/TIME Button is pressed on the remote.

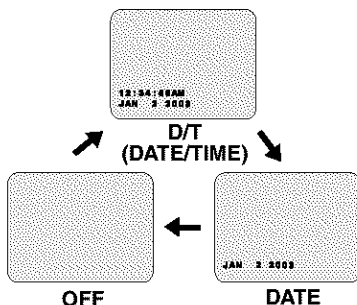

h Tape Speed Indication (Menu OSD: p. 108)

Indicates the tape speed (SP or LP).

i MNL Indication (pp. 28~31)

This display appears when AUTO/MANUAL is pressed to MANUAL.

For Your Information

CAMERA/VCR Mode

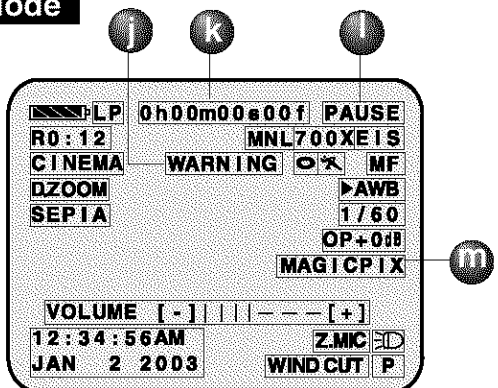

j **WARNING Indication** (pp. 100, 101)
The warning displays appear in the EVF and the LCD monitor.

k **Counter/Time Code**
The indication switches as shown below when the desired "C. DISPLAY" mode is selected from the menu. (Menu OSD: pp. 109, 111)

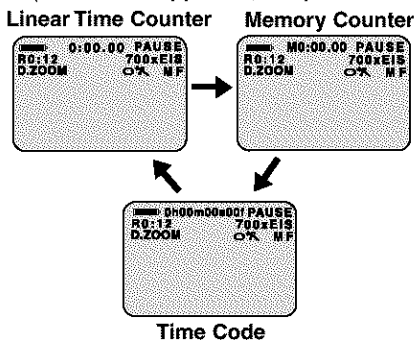

Memory Counter M 0:00.00

The Palmcorder will stop whenever it reaches the point where the counter was previously set to M 0:00.00 during audio dub, fast forward, or rewind.

Time Code 0h00m00s00f

The Palmcorder calculates and displays exactly where you are on any tape in terms of hours, minutes, seconds, and frames (30 frames = 1 second).

- This display cannot be reset.

IMPORTANT NOTE:

- Display must be set to ALL for MF, AE, W.BALANCE or BACK LIGHT indications to be displayed on the EVF or LCD Panel when selected.
- C.RESET does not work when C.DISPLAY is set to T.CODE.

l **Tape Mode Indications**

- REC** Recording.
- PHOTO** PhotoShot recording.
- PAUSE** Paused during recording.
- ▷** Playback.
- ||** Still.
- ▷** Slow (forward).
- ◁** Slow (reverse).
- ||▷** Frame Advance (forward).
- ◁||** Frame Advance (reverse).
- R▷** Repeat Playback.
- CHK** Recording Check.
- FF** Fast forward.
- REW** Rewind.
- ▷▷** FF Search.
- ◁◁** REW Search.
- BLANK** Blank Search.
- SEARCH** Index Search.

m **MAGICPIX Indication** (p. 41)
This display appears when MAGIC PIX is pressed.

CAMERA/VCR Mode

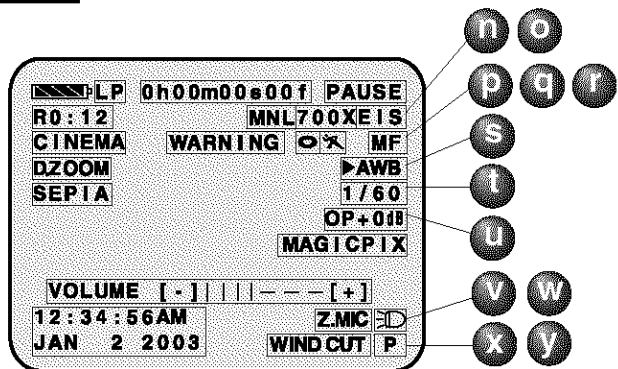

- n** **Zoom Magnification Level** (p. 40)
- b** **Digital EIS Indications** (p. 42)
This display appears when EIS is pressed.
- p** **Backlight Indication** (p. 24)
This display appears when BACK LIGHT is pressed.
- q** **PROGRAM-AE Indication** (p. 25)
- r** **Manual Focus Indication** (p. 29)
- s** **White Balance Indication** (p. 28)
- t** **Shutter Mode Indication** (p. 30)
- u** **Iris Indication** (p. 31)
- v** **Z.MIC Indication** (Menu OSD: p. 108)
This display appears when ZOOM MIC is set to ON.
- w** **Light Indication** (p. 8)
This display appears when LIGHT is set to ON.
- x** **WIND CUT Indication** (Menu OSD: p. 108)
This display appears when WIND CUT is set to ON.
- y** **Progressive Indication** (Menu OSD: p. 108)
This display appears when PROGRESSIVE is set to ON.

PHOTO Mode

[Photo Rec Mode]

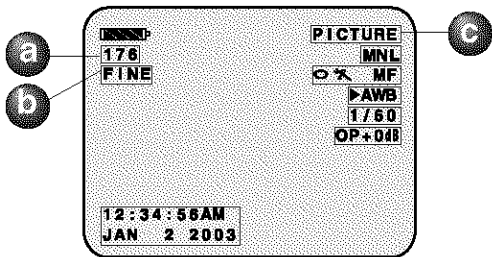

[Photo Play Mode]

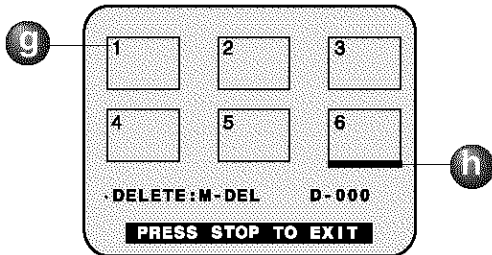
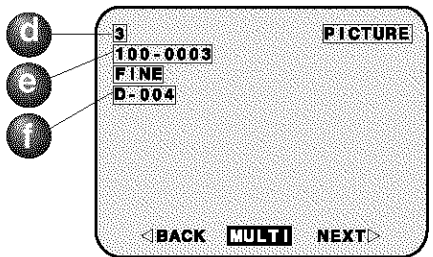

[Photo Play Mode]

- a** **Image Page Remaining Indication** (p. 49)
 - Image pages left in selected mode.
 - "0" flashes when memory is full.
 - Memory capacity provided all pictures are taken in the same mode:
 - "NORMAL" mode
 - Approx. 70 images (Supplied 8 MB Memory Card)
 - "FINE" mode
 - Approx. 30 images (Supplied 8 MB Memory Card)
- b** **REC MODE**
 - NORMAL or FINE mode.
 - Image Size:
 - "NORMAL" mode
 - 640 x 480 pixels
 - "FINE" mode
 - 1280 x 960 pixels
- c** **Recording Mode**
POWER is set to M-CARD.
- d** **Directory/Image Number**
- e** **DCF NO. (Design rule for Camera File system) Indication**
(Menu OSD: p. 112)
- f** **DPOF Indication** (p. 55)
- g** **Multi Image Playback page number**
- h** **Currently selected image is underlined in green**

Front View

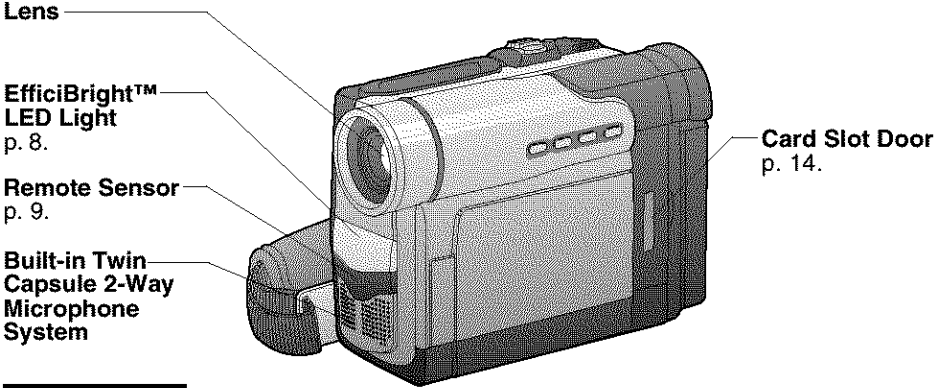

Rear View

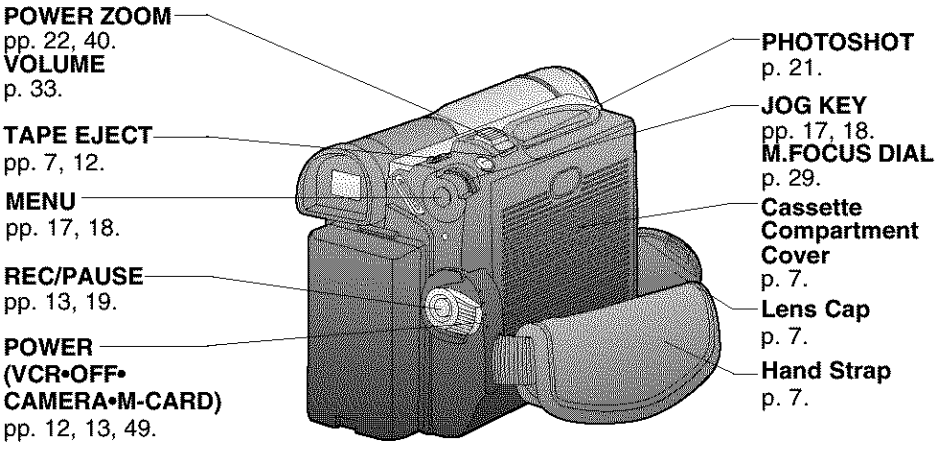

Side View

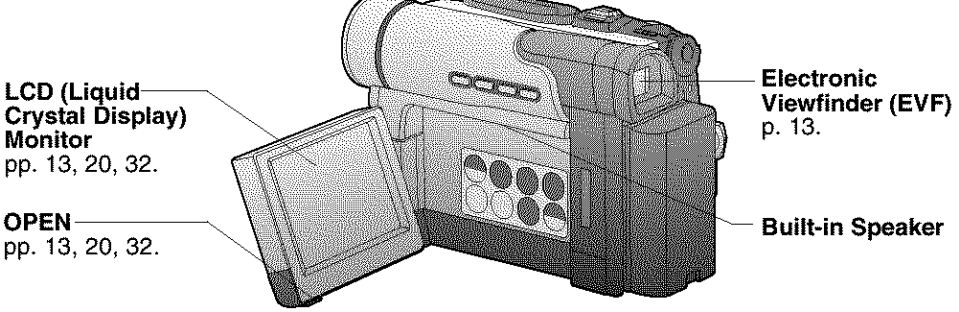

For Your Information

Rear View

USB Terminal
pp. 60, 75, 81.

Clock Battery Tray
p. 95.

DV Input/Output (i.LINK) Connector
pp. 48, 72.

A/V Output Connector
pp. 39, 47.

PHONE
p. 32.

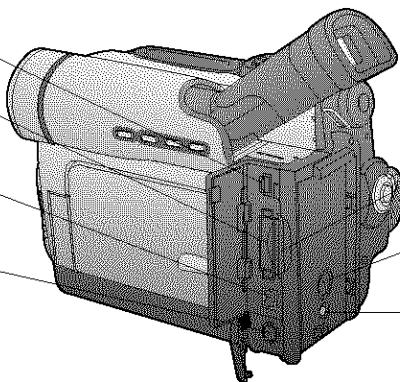

Card Slot
p. 14.

S-VIDEO Output Connector
pp. 39, 47.

DC IN Terminal
p. 16.

Side View

MAGIC PIX
p. 41.

LIGHT
p. 8.

REW
pp. 13, 32.

RECORDING CHECK
p. 23.

REC
p. 48.
FOCUS
p. 29.

AUTO/MANUAL
pp. 28~31.

EIS
p. 42.

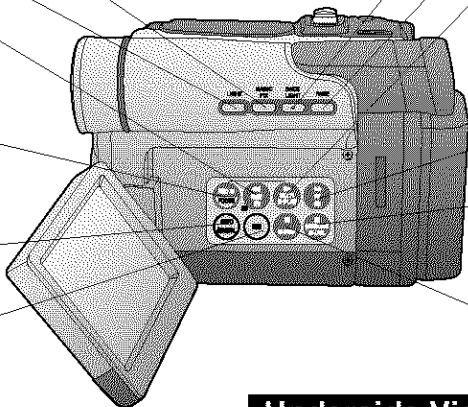

BACK LIGHT
p. 24.

FADE
p. 26.

PLAY
pp. 13, 32.

M-PLAY
pp. 51, 52.

MULTI
p. 38.

FF
p. 34.

PAUSE
pp. 34, 46, 48.
CAMERA STILL
p. 44.

STOP
pp. 13, 32.
M-STOP
pp. 51~54.

Back View

Vision Adjustment Control
pp. 13, 19.

Shoulder Strap Attachment Ring
p. 7.

POWER Lamp
p. 19.

Shoulder Strap Attachment Ring
p. 7.

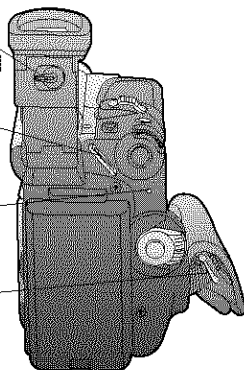

Underside View

BATTERY RELEASE
pp. 15, 16.

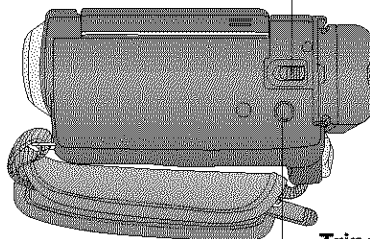

Tripod Receptacle

AC Adaptor

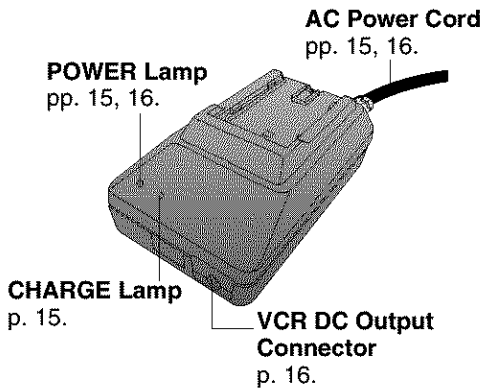

CAUTION:
This unit will operate on 110/120/220/240 V AC. An AC plug adaptor may be required for voltages other than 120 V AC. Please contact either a local or foreign electrical parts distributor for assistance in selecting an alternate AC plug. We recommend using the accessory power plug adaptor (VJSS0070/KZDB4ZE00001) in an area which has special AC outlets.

Remote Control (Optional)

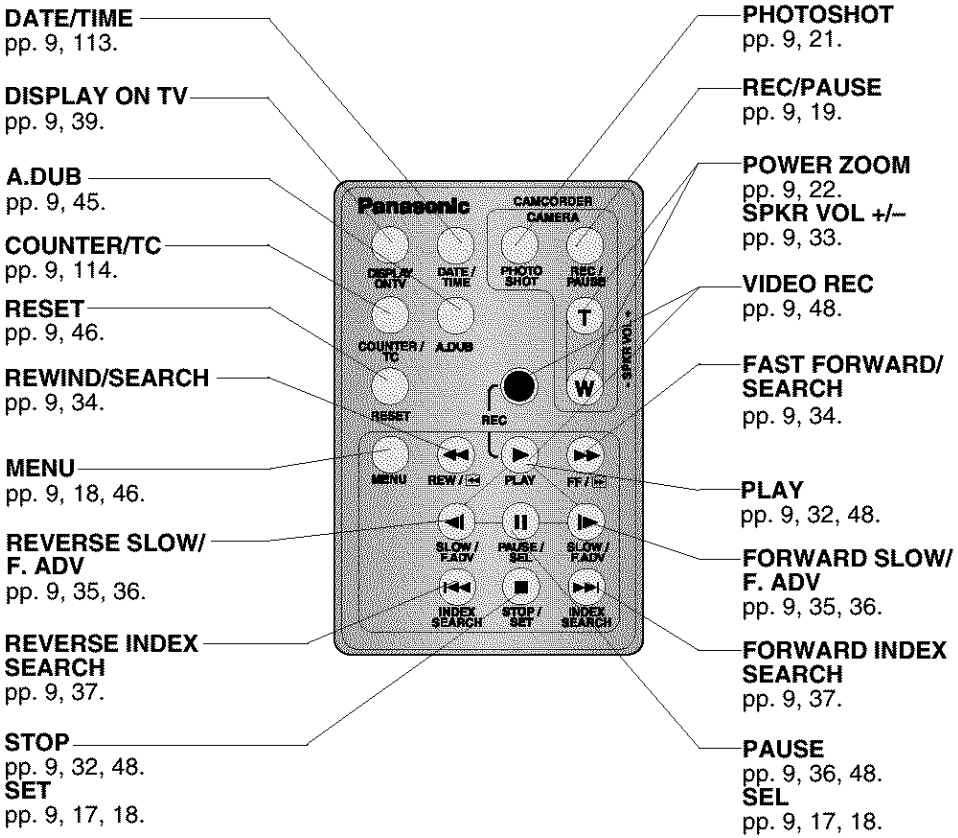

For Your Information

A	
About the Memory Card	94
AC Adaptor	6, 15, 16, 92
Accessories (Optional)	92
Accessories (Supplied)	6
A/V Cable	6, 39
Approximate Brightness Values	96
Audio Dubbing	45, 46
Audio/Video Fade In/Out	26

B	
Backlight	24
Battery Pack	6, 12, 15, 92
Battery Remaining Indication	113
Battery Warning	100
Before Requesting Service	98, 99
Blank Search	33

C	
Card PhotoShot	49
CD-ROM	6, 57
CINEMA Mode	24
Cleaning Care for Video Heads	98
Clock Battery	95, 100
Clock Set	17
Connecting Earphone	32
Copying from Digital Equipment	48
Copying your Tapes	47
Customer Services Directory	103

D	
Date and Time Indication ..	113
DC Power Cable	6, 16, 92
Delete All Image Pages	53
Delete Specific Images	52
DEW Indication	100
Digital E.I.S.	42
Digital Functions	43
Digital PhotoShot™ Mode ..	21
Digital Video Cassette Tape ..	6
Digital Zoom	40, 41
DV Interface Cable (i.LINK) ..	48, 72, 92
DPOF Setting	55

E	
Easy Cassette Eject	7
EfficiBright™ LED Light	8
Erase Protection Tab	6
EVF/LCD Monitor Indications ..	113~116

F	
Fast Forward/Rewind Check ..	34
Focus	29
Format the Memory Card ...	54
Frame by Frame Advance ..	36

H	
Hand Strap	7
High Speed Shutter	30

I	
Important Safeguards	3
Index of Controls	117~119
Index Search	37
Iris	31

J	
Jog Search	36

L	
LCD/EVF Setting	20
Lens Cap	6, 7, 19
Lens Cap Strap	6, 7
Limited Warranty	102

M	
MagicPix™ Images	41
Memory Counter	114
Memory Stop Editing	46
MENU OSD	108~112
Memory Card	6, 14, 92

O	
On-Screen Display (OSD) ..	100, 101

P	
Palmcorder Accessory Order ..	93
Form	78, 79
Palmcorder File Converter ..	78, 79
Palmcorder USB Device ..	75~77
Driver/SD Drive	75~77
Photo Title	27

PHOTOVU/MPEG4 Movie	
Messenger™ System ..	60~71
PHOTOVU/MPEG4 Movie	
Messenger™ System ..	73, 74
(i.LINK)	73, 74
Picture in Picture (PinP) ..	44
Playback Still Images	51
Playback using the LCD ..	32
Monitor	32
Precautions	4
Program AE	25
Progressive PhotoShot™ ..	21
Mode	21

Q	
Quick Guide	12, 13, 14

R	
Rapid Visual Search	34
Recording Check	23
Recording Images From a ..	50
Tape	50
Recording Still Pictures	23
Remote Control (Optional) ..	9, 10, 92, 119
Remote Controlling Two ..	10
Palmcorders	10
Repeat Playback	33
Request for Service Notice ..	101

S	
Safety Precautions	2
Self Demo Mode	11
Self Recording	23
Shoulder Strap	6, 7
Simple Recording	19
Slow Motion Playback	35
Spanish Quick Use Guide ..	104~107
Specifications	97
STILL Picture	34
Strobe Multi Mode	38
Supplying Power	15, 16

T	
Table of Contents	5
Tape Remaining Indications ..	113
Tape Speed	6
Tape Warning	100
Transferring Your Images ..	90, 91
(Macintosh)	90, 91
Transferring Your Images ..	56~59
(Windows)	56~59
Transferring Your Images ..	72
(i.LINK) (Windows)	72

U	
USB Cable	6, 60, 75, 81, 90
Using the Palmcorder Menu ..	18

V	
Variable Speed Search	35
VHF Connecting Cable	47
Volume Display	33, 113

W	
Warning Indications	89
Web Camera	80~88
White Balance	28
WIND CUT	31

Z	
Zoom In/Out	22
Zoom Microphone	22

Panasonic Consumer Electronics Company,
Division of Matsushita Electric Corporation of America
 One Panasonic Way Secaucus, New Jersey 07094

Panasonic Sales Company ("PSC"),
Division of Matsushita Electric of Puerto Rico, Inc.
 Ave. 65 de Infanteria, Km. 9.5 San Gabriel Industrial Park Carolina,
 Puerto Rico 00985



Printed in Japan
 LSQT0653A
 S1202A1013