

IMPORTANT MANUAL Do Not Throw Away

SEARS

**Operator's
Manual**

**Model No.
358.798420**

**CUSTOMER
ASSISTANCE
1-800-235-5878**

**HOURS (CST)
Mon. - Sat. 7 a.m. - 7 p.m.
Sun. 10 a.m. - 7 p.m.**



**WARNING:
READ THE OPERATOR'S
MANUAL AND FOLLOW
ALL WARNINGS AND
SAFETY INSTRUCTIONS.
FAILURE TO DO SO CAN
RESULT IN SERIOUS
INJURY.**

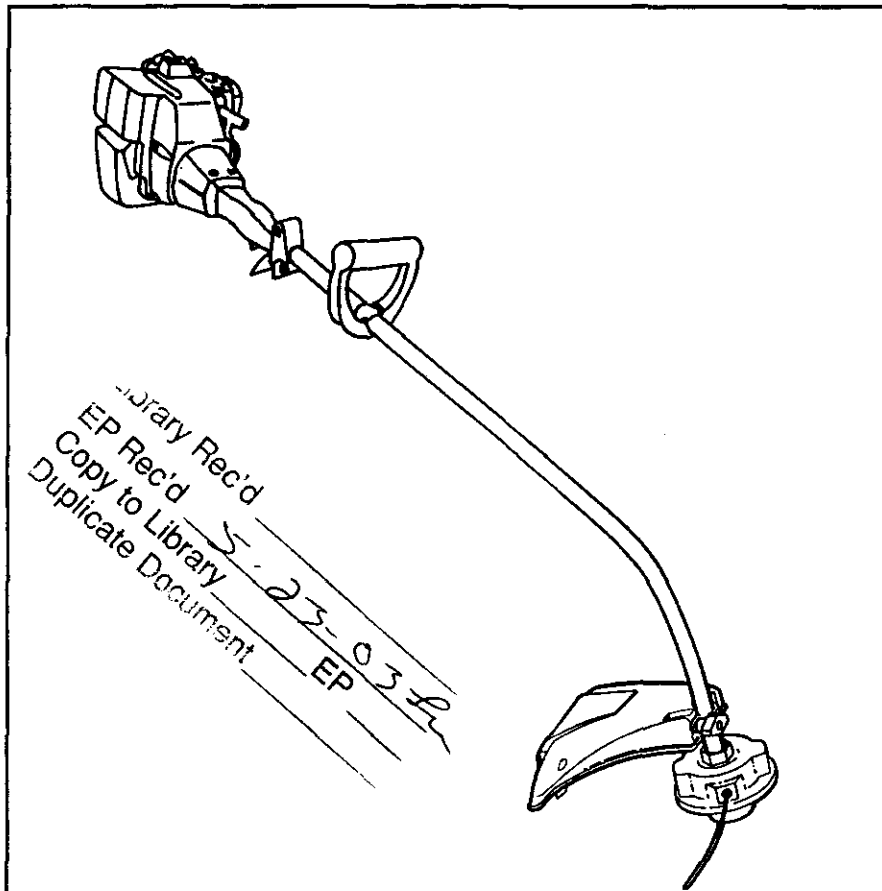

Always Wear Eye Protection

CRAFTSMAN®

**21 cc/1.3 cu. in. 2-CYCLE ENGINE
16 Inch Semi-Automatic Head®
GAS WEEDWACKER®**

- Assembly
- Operation
- Customer Responsibilities
- Service and Adjustments
- Repair Parts

Sears, Roebuck and Co., Hoffman Estates, IL 60179 U.S.A.

SAFETY RULES



CAUTION: ALWAYS DISCONNECT SPARK PLUG WIRE AND PLACE WIRE WHERE IT CANNOT CONTACT SPARK PLUG TO PREVENT ACCIDENTAL STARTING WHEN SETTING UP, TRANSPORTING, ADJUSTING OR MAKING REPAIRS.

OPERATOR SAFETY

- Always wear safety eye protection.
- Always wear long pants, long sleeves, boots and gloves. Wearing safety leg guards is recommended. Do not go barefoot or wear sandals, short pants, short sleeves. Being fully covered helps to protect you from pieces of toxic plants thrown by the cutting head.
- Secure hair so it is above shoulder length. Secure loose clothing, jewelry, or clothing with loosely hanging ties, straps, tassels, etc.; they can be caught in moving parts.
- Do not operate this unit when you are tired, ill, or under the influence of alcohol, drugs, or medication.
- Wear hearing protection if you use this unit for more than 1-1/2 hours per day.
- Never start or run the engine inside a closed room or building. Breathing exhaust fumes can kill.
- Keep handles free of oil and fuel.
- If situations occur which are not covered in this manual, use care and good judgement.

UNIT/MAINTENANCE SAFETY

- Look for and replace damaged or loose parts before each use. Look for and repair fuel leaks before use. Keep the unit in good working condition.
- Use only .080" diameter monofilament line. Never use wire, rope, string, etc.
- Keep the cutting line at the proper length.
- Make sure the unit is maintained and assembled correctly as listed in this manual.
- Install the required shield properly before using the unit.
- Use only the specified trimmer head.
- Make carburetor adjustments with the lower end supported to prevent the trimmer line from contacting any object. Hold unit by hand.
- Keep others away when making carburetor adjustments.
- Use only quality SEARS accessories and replacement parts as recommended for this unit.
- Have all maintenance and service not explained in this manual performed by your SEARS Service Center.

FUEL SAFETY

- Mix and pour fuel outdoors.
- Keep away from sparks or flames.
- Use a container approved for fuel.

- Do not smoke or allow smoking near fuel or the unit or while using the unit.
- Wipe up all fuel spills before starting engine.
- Move at least 10 feet (3 meters) away from fueling site before starting engine.
- Stop engine and allow unit to cool before removing fuel cap.

CUTTING SAFETY

- Inspect the area to be cut before each use. Remove objects (rocks, broken glass, nails, wire, string, etc.) which can be thrown or become entangled in the semi-automatic head.
- Keep others including children, animals, bystanders and helpers at least 50 feet (15 meters) away. Stop the engine immediately if you are approached.
- Always keep the engine on the right-hand side of your body.
- Hold the unit firmly with both hands.
- Keep firm footing and balance. Do not over-reach.
- Keep the semi-automatic line head below waist level.
- Do not raise the engine above your waist.
- Keep all parts of your body away from semi-automatic head and muffler when engine is running.
- Cut from your right to your left.
- Use only for jobs explained in this manual.

TRANSPORTING AND STORAGE

- Stop the unit before transporting.
- Allow the engine to cool, and secure the unit before storing or transporting in a vehicle.
- Empty the fuel tank before storing or transporting the unit. Use up any fuel left in the carburetor by starting the engine and letting the engine run until it stops.
- Store unit and fuel in an area where fuel vapors cannot reach sparks or open flames from water heaters, electric motors or switches, furnaces, etc.
- Store unit so the line limiter cannot accidentally cause injury.
- Store the unit out of the reach of children.

SAFETY NOTICE

Exposure to vibrations through prolonged use of gasoline powered hand units could cause blood vessel or nerve damage in the fingers, hands, and joints of people prone to circulation disorders or abnormal swellings. Prolonged use in cold weather has been linked to blood vessel damage in otherwise healthy people. If symptoms occur such as numbness, pain, loss of strength, change in skin color or texture, or loss of feeling in the fingers, hands or joints, discontinue the use of this unit and seek medical attention. An anti-vibration system does not guarantee the avoidance of these problems. Users who operate power tools on a continual and regular basis must monitor closely their physical condition and the condition of this unit.



LOOK FOR THIS SYMBOL TO POINT OUT IMPORTANT SAFETY PRECAUTIONS. IT MEANS — ATTENTION!!! BECOME ALERT!!! YOUR SAFETY IS INVOLVED.

SAFETY RULES



DANGER

THIS POWER UNIT CAN BE DANGEROUS! THIS UNIT CAN CAUSE SERIOUS INJURY OR BLINDNESS TO THE OPERATOR AND OTHERS. THE WARNINGS AND SAFETY INSTRUCTIONS IN THIS MANUAL MUST BE FOLLOWED TO PROVIDE REASONABLE SAFETY AND EFFICIENCY IN USING THIS UNIT. THE OPERATOR IS RESPONSIBLE FOR FOLLOWING THE WARNINGS AND INSTRUCTIONS IN THIS MANUAL AND ON THE UNIT. READ THE ENTIRE OPERATOR'S MANUAL BEFORE ASSEMBLING AND USING THE UNIT! RESTRICT THE USE OF THIS POWER UNIT TO PERSONS WHO READ, UNDERSTAND AND FOLLOW THE WARNINGS AND INSTRUCTIONS IN THIS MANUAL AND ON THE UNIT. NEVER ALLOW CHILDREN TO USE THIS TOOL.

THIS UNIT IS DESIGNED FOR LINE TRIMMER USE ONLY. NEVER USE ANY OTHER CUTTING ATTACHMENT WITH THIS UNIT. BLADES AND HEADS WITH FLAILING DEVICES CAN CAUSE SERIOUS INJURY.



WARNING

TRIMMER LINE CAN THROW OBJECTS VIOLENTLY. YOU CAN BE BLINDED OR INJURED. WEAR EYE AND LEG PROTECTION.

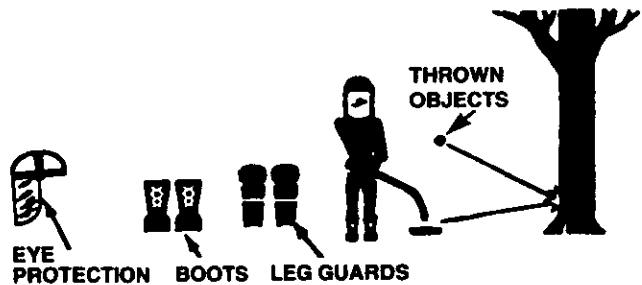

HAZARD ZONE FOR THROWN OBJECTS. TRIMMER LINE CAN THROW OBJECTS VIOLENTLY. OTHERS CAN BE BLINDED OR INJURED. KEEP PEOPLE AND ANIMALS 50 FEET (15 METERS) AWAY.

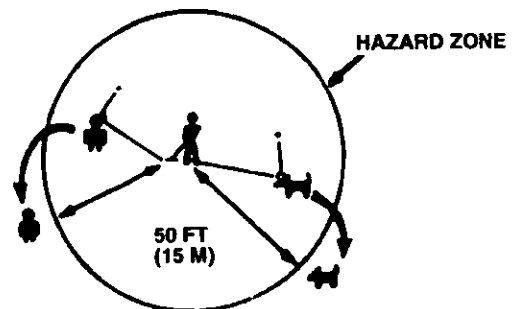

READ OPERATOR'S MANUAL. FOLLOW ALL WARNINGS AND INSTRUCTIONS. FAILURE TO DO SO CAN RESULT IN SERIOUS INJURY.



CONGRATULATIONS on your purchase of a Sears Craftsman Gas Weedwacker. It has been designed, engineered and manufactured to give you the best possible dependability and performance.

Should you experience any problems you cannot easily remedy, please contact your nearest Sears Service Center/Department. Sears has competent, well trained technicians and the proper tools to service or repair this unit.

Please read and retain this manual. The instructions will enable you to assemble and maintain your unit properly. Always observe the "SAFETY RULES."

MODEL NUMBER:	358.798420
DATE CODE/SERIAL NO.:	_____
DATE OF PURCHASE:	_____
THE MODEL AND SERIAL NUMBER WILL BE FOUND ON THE PRODUCT.	
YOU SHOULD RECORD BOTH SERIAL NUMBER AND DATE OF PURCHASE AND KEEP IN A SAFE PLACE FOR FUTURE REFERENCE.	

MAINTENANCE AGREEMENT

A Sears Maintenance Agreement is available on this product. Contact your nearest Sears Store for details.

CUSTOMER RESPONSIBILITIES

- Read and observe the safety rules.
- Follow a regular schedule in maintaining, caring for, and using your unit.
- Follow the instructions under "Customer Responsibilities" and "Storage" sections of this Operator's Manual.

PRODUCT SPECIFICATIONS

CUTTING PATH 16"
 TRIMMER LINE080" Diameter
 SEMI-AUTOMATIC HEAD ROTATION.....Clockwise (for operator)
 ENGINE 21cc, 2-cycle Air Cooled
 FUEL/OIL MIX RATIO 40:1 (3.2 oz. oil per gallon gas)
 IGNITION..... Solid State
 (air gap .010" to .014")
 IGNITION TIMING Non-adjustable, Fixed
 SPARK PLUG Champion (RCJ-8Y)
 SPARK PLUG GAP025"
 ENGINE RPM..... 8,000 RPM Max

SPECIAL NOTICE

For users on U.S. Forest Land and in some states, including California (Public Resources Codes 4442 and 4443), Idaho, Maine, Minnesota, New Jersey, Oregon, and Washington: Certain internal combustion engines operated on forest, brush, and/or grass-covered lands in the above areas are required to be equipped with a spark arrestor, maintained in effective working order, or the engine must be constructed, equipped, and maintained for the prevention of fire. Check with your state or local authorities for regulations pertaining to these requirements. Failure to follow these requirements is a violation of the law. This unit is not factory-equipped with a spark arrestor; however, a spark arrestor is available as an optional part. If a spark arrestor is required in your area, contact your SEARS Service Center/Department for the correct kit.

Manufactured under one or more of the following U.S. patents: 5,383,427; 5,367,988; 5,345,684; 5,343,831; 5,276,968; 5,269,665; 5,020,223; 4,940,028; 4,897,923; 4,852,258; 4,846,123; 4,841,929; 4,835,867; 4,825,548; 4,823,465; 4,819,742; 4,798,185; 4,508,068; 4,483,069; 4,451,983; 4,366,622; 4,366,621; 4,352,243; 4,347,666; 4,290,200; 4,286,675; 4,236,312; 4,177,561; 4,172,322; 4,167,812; 4,162,575; 4,161,820; 4,122,653; 4,104,797; Re.32,266; D344,088; D324,051; D304,196; D276,160. Other U.S. and foreign patents pending.

FULL ONE YEAR WARRANTY ON CRAFTSMAN GAS-POWERED WEEDWACKER® LINE TRIMMER

For one year from the date of purchase, when this Craftsman Gas-Powered Weedwacker® Line Trimmer is maintained, lubricated and tuned up according to the operating and maintenance instructions in the Operator's Manual, Sears will repair, free of charge, any defect in materials or workmanship.

This warranty excludes nylon line, spark plug, and air filter, which are expendable parts and become worn during normal use.

If this Weedwacker® Line Trimmer is used for commercial purposes, this warranty applies for only 90 days from the date of purchase. If this Weedwacker® Line Trimmer is used for rental purposes, this warranty applies for only 30 days from date of purchase. This warranty applies only while this product is in use in the United States.

WARRANTY SERVICE IS AVAILABLE BY RETURNING THE WEEDWACKER® LINE TRIMMER TO THE NEAREST SEARS SERVICE CENTER IN THE UNITED STATES.

This warranty gives you specific legal rights, and you may also have other rights which vary from state to state.

SEARS, ROEBUCK AND CO., D/817WA, Hoffman Estates, IL 60179

TABLE OF CONTENTS

Safety Rules.....	2	Customer Responsibilities.....	15
Product Specifications.....	4	Service and Adjustments.....	18
Warranty.....	4	Storage.....	21
Accessories.....	6	Trouble Shooting.....	22
Assembly.....	7	Repair Parts.....	23
Operation.....	9	Repair Parts Ordering/Service.....	Back Cover







INDEX

A		K	
Accessories.....	6	Know Your Weedwacker.....	9
Adjustments		L	
Assist Handle.....	10	Line Advancement.....	10
Carburetor.....	20	Line Replacement.....	18
Air Filter.....	16	M	
Assembly.....	7	Maintenance Schedule.....	15
Assist Handle.....	10	Model Number.....	4
C		O	
Carburetor Adjustments.....	20	Operation.....	9
Carton Contents.....	5	Ordering Repair Parts.....	Back Cover
Controls.....	10	R	
Customer Responsibilities.....	15	Repair Parts.....	23
Spark Plug.....	4	Ordering.....	Back Cover
Cutting Techniques.....	12	S	
D		Service and Adjustments.....	18
Debris Shield.....	7	Spark Arrestor Screen.....	16
Drive Shaft Lubrication.....	16	Specifications.....	4
E		Starting.....	14
Engine		Storage.....	21
Fuel/Oil.....	13	T	
Spark Plug.....	4	Trouble Shooting.....	22
Starting.....	14	W	
Storage.....	21	Warranty.....	4
F			
Fueling.....	13		
Fuel Filter.....	17		

ACCESSORIES

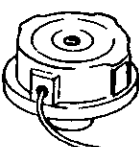
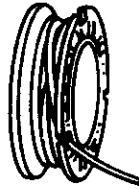
These accessories and attachments were available when the unit was originally purchased. They are also available at most Sears retail outlets and service centers. Most Sears stores can order these items for you when you provide the model number of your unit.

Accessories

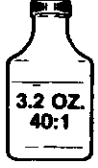
SAFETY GOGGLES 	HEARING PROTECTION 	SEMI-AUTOMATIC HEAD 	SPOOL WITH LINE 	BULK LINE  .080" 80 FT. 200 FT. 400 FT.	SPARK PLUG 	AIR FILTER 	GAS CAN 	SEARS 2-CYCLE ENGINE OIL  3.2 OZ. 40:1
--	--	---	---	--	---	--	---	---

CARTON CONTENTS

Hardware shown full size

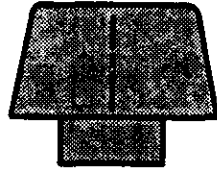

(1) Debris Shield Knob

Parts bag contents not shown full size

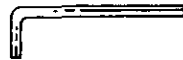

Long Hex Key

Parts packed separately in carton

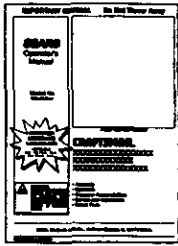

Operator's Manual



Plastic Debris Shield

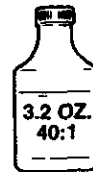

Engine Oil

ASSEMBLY

TOOLS REQUIRED FOR ASSEMBLY

- Torque Wrench (optional) – Reference torque values are provided throughout this manual for tightening hardware.
- Long hex key (included)
- Adjustable wrench or large pliers

TO REMOVE WEEDWACKER FROM CARTON

- Remove loose parts bag included with Weedwacker.
- Remove your Weedwacker from the packing material.
- Remove the packing material from your Weedwacker, including the clear protective cover from the tube.
- You may use the opened packing material as a work surface.

NOTE: Model 358.798420 is partially assembled.

- After removing the contents from the carton, check parts against the Carton Contents list.
- Examine the parts for damage. Do not use damaged parts.
- *Notify Customer Assistance at 1-800-235-5878 immediately if a part is missing or damaged.*

NOTE: It is normal to hear the fuel filter rattle in an empty fuel tank.

ASSEMBLY

HOW TO ASSEMBLE YOUR WEEDWACKER



WARNING:
IF THIS UNIT IS RECEIVED ASSEMBLED, REVIEW ALL STEPS IN THIS SECTION TO BE SURE ASSEMBLY IS CORRECT AND PROPERLY ADJUSTED FOR THE OPERATOR.

ASSIST HANDLE ASSEMBLY (Fig. 1)



CAUTION: WHEN ADJUSTING THE ASSIST HANDLE FOR COMFORT, BE SURE THAT THE ASSIST HANDLE REMAINS BETWEEN THE TRIGGER HOUSING AND THE SAFETY LABEL. FIGURE 1.

NOTE: For pre-assembled units, simply loosen assist handle knob and rotate assist handle to the operating position, being sure to align between safety label and throttle trigger housing.

- Rotate assist handle from left to right to tilt the angle of the semi-automatic head when cutting a large, slopes area such as a ditch bank.
- Tighten assist handle knob securely.

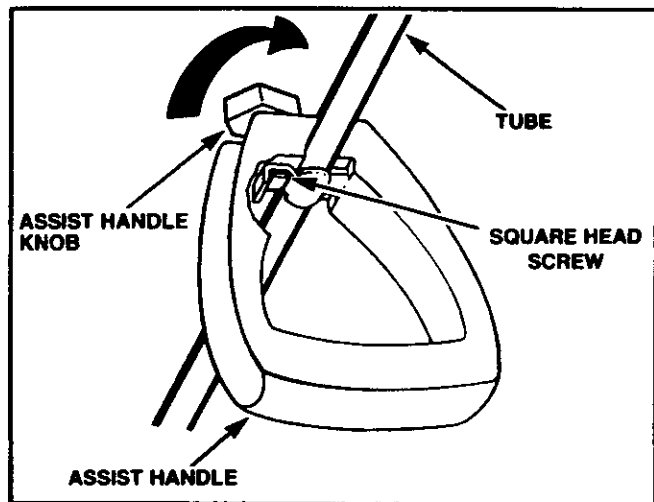

Figure 1

INSTALLING THE DEBRIS SHIELD (Fig. 2)



WARNING:
THE LINE LIMITER IS SHARP AND CAN CUT YOU. BE SURE TO WEAR GLOVES WHILE WORKING WITH THE LINE LIMITER.

THE DEBRIS SHIELD MUST BE PROPERLY INSTALLED FOR ALL LINE TRIMMER USAGE. THE DEBRIS SHIELD PROVIDES PARTIAL PROTECTION FROM THE RISK OF THROWN OBJECTS TO THE OPERATOR AND OTHERS.

DO NOT ALTER OR REMOVE THE TAB ON THE SHIELD BRACKET. WHEN INSTALLED CORRECTLY, THE BRACKET TAB ENSURES PROPER DEBRIS SHIELD ALIGNMENT. FAILURE TO INSTALL THE DEBRIS SHIELD IN POSITION SHOWN IN ILLUSTRATION CAN RESULT IN SERIOUS INJURY TO THE OPERATOR.

- Insert the debris shield bracket, attached to the tube, into the slot in the debris shield.
- Turn debris shield while aligning and inserting debris shield screw into hole located in debris shield bracket.
- Assemble the debris shield knob onto the debris shield screw. Tighten securely.

NOTE: It is possible that a small space will be left between the debris shield and the debris shield bracket when the shield screws are fully tightened.

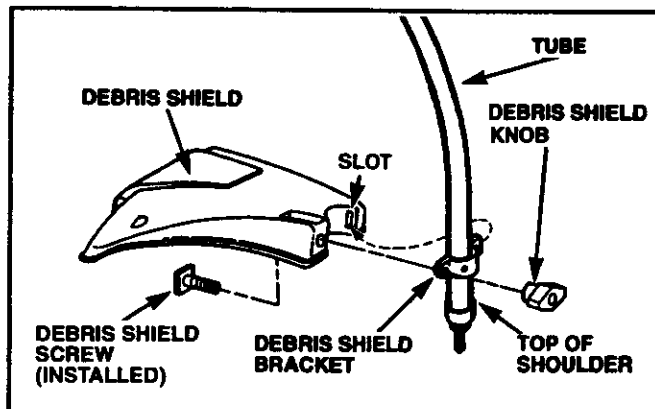

Figure 2

SEMI-AUTOMATIC HEAD ASSEMBLY (Fig. 3)

- Place the dust cup over the hex nut on the bottom of the tube. The hex nut should fit completely inside the dust cup.
- Hold the dust cup with a wrench to keep the arbor shaft from turning.
- Thread the semi-automatic head onto the arbor shaft against the dust cup and tighten firmly with your hand.

NOTE: Unless semi-automatic head is tightened adequately, it can unthread when engine is started or stopped. If the situation occurs, reinstall the semi-automatic head and tighten more securely.

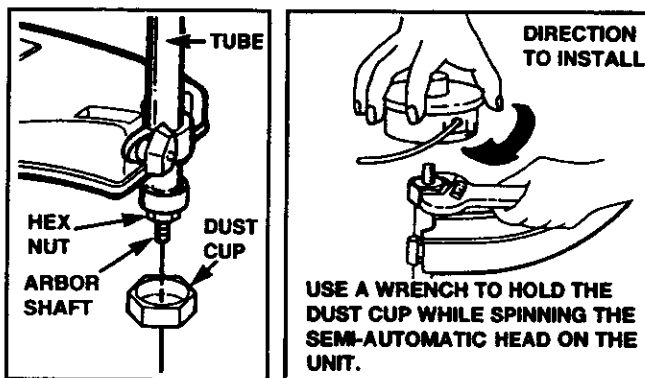

Figure 3

CHECK LIST

- Check all fasteners. make sure they are tight and there are no loose parts.
- Check to make sure the *throttle cable* is positioned correctly.
- With the unit held in the operating position, adjust the assist handle up or down the tube for best comfort and balance before first use.

OPERATION

KNOW YOUR WEEDWACKER (Fig. 4)

READ THIS OPERATOR'S MANUAL AND SAFETY RULES BEFORE OPERATING YOUR WEEDWACKER. Compare the illustrations with your unit to familiarize yourself with the location of the various controls and adjustments. Save this manual for future reference.

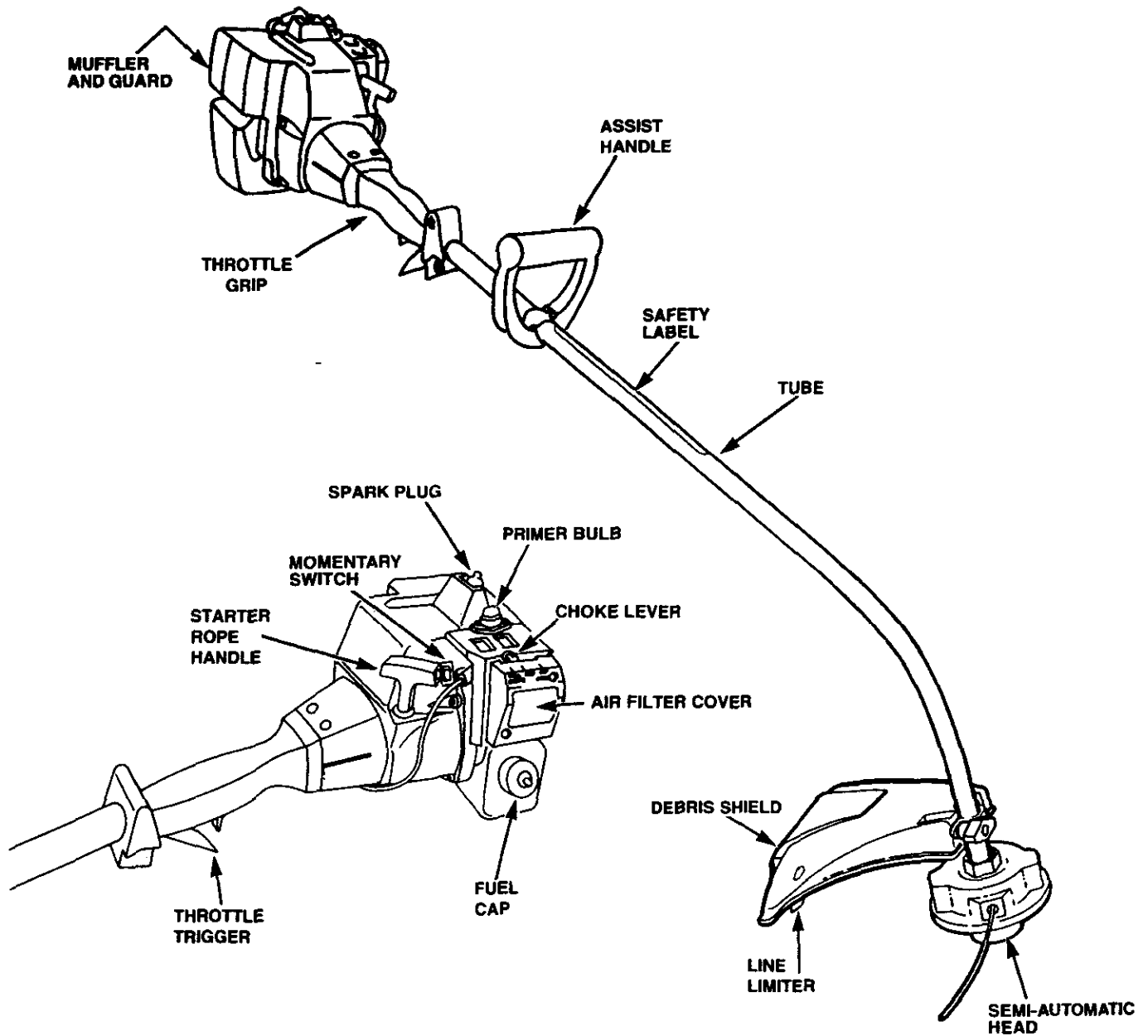

Figure 4

The **MOMENTARY SWITCH** is used to stop the engine.

The **STARTER ROPE HANDLE** is used for starting the engine.

The **PRIMER BULB** circulates fuel to the carburetor.

The **ASSIST HANDLE** aids in the control of the unit.

The **LINE LIMITER** cuts trimmer line automatically to the correct length.

The **CHOKE LEVER** is used for starting cold engine.

The **THROTTLE TRIGGER** controls engine speed.

The **SEMI-AUTOMATIC HEAD** contains spool of line which advances when head is tapped on the ground.

OPERATION – SAFETY

LINE TRIMMER SAFETY



WARNING:

THE RAPIDLY MOVING LINE CAUSES OBJECTS TO BE THROWN VIOLENTLY. THE DEBRIS SHIELD WILL NOT PROVIDE COMPLETE PROTECTION TO THE OPERATOR OR OTHERS. THE OPERATOR MUST WEAR A SAFETY FACE SHIELD OR GOGGLES. ALWAYS WEAR HEAVY, LONG PANTS AND BOOTS. KEEP OTHERS AT LEAST 50 FEET (15 METERS) AWAY.

THIS UNIT WILL THROW OBJECTS AND CUT. KEEP OTHERS INCLUDING CHILDREN, ANIMALS, BYSTANDERS AND HELPERS AT LEAST 50 FEET (15 METERS) AWAY FROM THE OPERATOR AND UNIT. STOP THE ENGINE IF YOU ARE APPROACHED. IN AREAS WHERE OTHER PEOPLE AND ANIMALS ARE PRESENT, SUCH AS NEAR SIDEWALKS, STREETS, HOUSES, ETC., IT IS STRONGLY RECOMMENDED THAT THE OPERATOR USE THE BUDDY SYSTEM; THAT IS, HAVE ANOTHER PERSON SERVE AS A "LOOK-OUT," KEEPING HIMSELF AND OTHERS AT LEAST 50 FEET (15 METERS) AWAY FROM THE OPERATOR.

SEMI-AUTOMATIC HEAD PARTS THAT ARE CHIPPED, CRACKED OR DAMAGED IN ANY OTHER WAY CAN FLY APART AND CAUSE SERIOUS INJURY. DO NOT USE. REPLACE DAMAGED PARTS BEFORE USING THE UNIT.

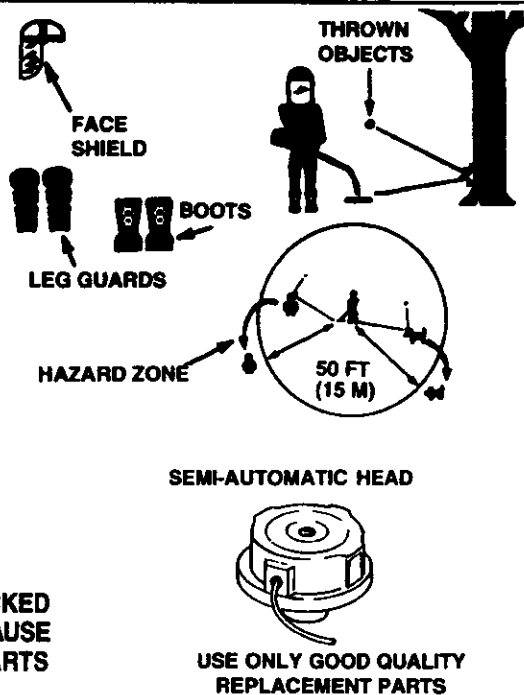

OPERATOR SAFETY

- Always wear eye protection when operating, servicing, or performing maintenance on your unit. Refer to "Accessories."
- Do not operate this unit when you are tired, ill, or under the influence of alcohol, drugs or medication.
- Always wear heavy, long pants, long sleeves, boots, and gloves. Do not go barefoot or wear sandals, short pants. Loose clothing, jewelry or clothing with loosely hanging straps, ties, tassels, etc. can be caught in moving parts. Secure hair so it is above shoulder length. Being fully covered will help protect you from pieces of toxic plants such as poison ivy thrown by the semi-automatic head, which could be more of a hazard than touching the plant itself.
- Do not swing the unit with such force that you are in danger of losing your balance.
- Never start or run the engine inside a closed room or building. Breathing exhaust fumes can kill.
- Keep handles free of oil and fuel.

UNIT SAFETY

- Inspect the entire unit before each use. Replace damaged parts. Check for fuel leaks and make sure all fasteners are in place and securely fastened.
- Use only .080" diameter good quality monofilament line. Never use wire, rope, or string, etc.
- Be sure the debris shield is properly attached.
- Make sure semi-automatic head is properly installed and securely fastened. Refer to "Assembly."
- Make carburetor adjustments with the drive shaft housing supported to prevent the semi-automatic head from contacting any object.
- Keep others away when making carburetor adjustments.
- Use only good quality Sears accessories or attachments.

CUTTING SAFETY

Inspect the area to be cut before each use. Remove objects (rocks, broken glass, nails, wire, string, etc.) which can be thrown or become entangled in the semi-automatic head.

- Always keep the engine on the right side of your body.
- Hold the unit firmly with both hands.
- Keep firm footing and balance. Do not over-reach.
- Keep the semi-automatic head below waist level.
- Do not raise the engine above your waist.
- Keep all parts of your body away from the semi-automatic head and muffler when engine is running.
- Use only for jobs explained in this manual.
- Cut at full throttle.
- Cut from your right to your left.

OPERATION

HOW TO USE YOUR WEEDWACKER

STOPPING YOUR ENGINE

- Move momentary switch to the "Off" position. Do not release until the engine has completely stopped.
- If engine does not stop, move the choke lever to the "Full Choke" position.

CONTROLS (Fig. 5, 6 & 7)

THROTTLE TRIGGER

- The throttle trigger allows for variable control of engine speed.
- The throttle trigger is actuated by the index finger on your right hand.

CHOKE

- The choke is set by moving the choke lever up fully for cold or refueled engine starts.

PRIMER BULB

- The primer bulb is used to circulate fuel to the carburetor .
- The primer bulb is activated by pressing on it with your thumb.

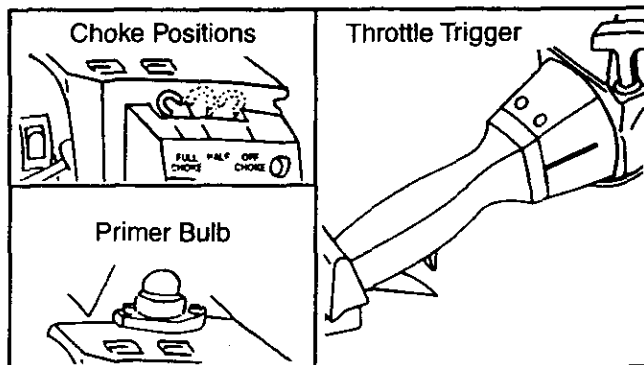

Figure 5

ASSIST HANDLE

The assist handle is used to aid in the control of the unit, as well as a barrier between the operator and the cutting head.

TO ADJUST THE ASSIST HANDLE FOR BALANCE AND CONTROL:

- Turn off the engine before adjusting assist handle.
- Adjust the assist handle by slightly loosening the assist handle screws and rotating the assist handle forward or backward. Ensure the mounting brackets remain between the arrows on the assist handle.
- Tighten the assist handle screws before starting the engine.

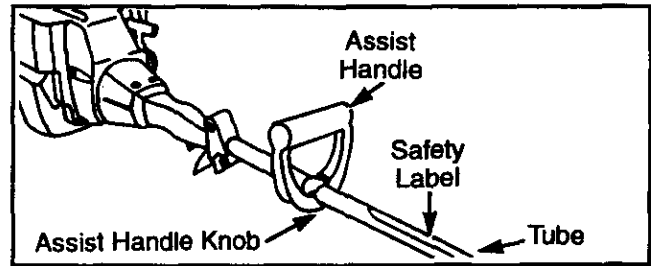

Figure 6

TRIMMER LINE ADVANCE

Your Weedwacker is equipped with a semi-automatic trimmer head. The most efficient line length is the maximum length allowed by the line limiter.

TO ADVANCE THE LINE:

- Operate the engine at full throttle.
- Hold the semi-automatic head parallel to and above a grassy area.
- Tap the bottom of the semi-automatic head lightly on the ground one time. Approximately 2 inches of line will be advanced with each tap.

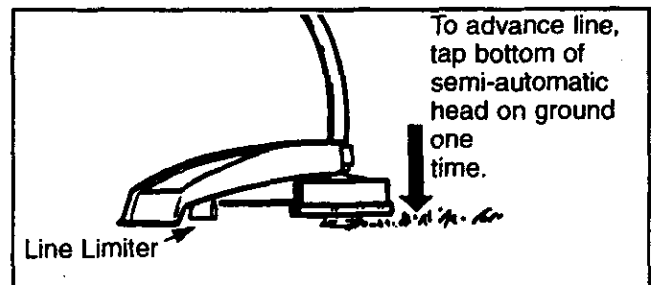

Figure 7

OPERATION

BEFORE STARTING ENGINE:



WARNING:

BE SURE TO READ THE FUEL SAFETY INFORMATION IN THE SAFETY RULES SECTION ON PAGE 2 OF THIS MANUAL BEFORE YOU BEGIN.

IF YOU DO NOT UNDERSTAND THE FUEL SAFETY SECTION DO NOT ATTEMPT TO FUEL YOUR UNIT; SEEK HELP FROM SOMEONE THAT DOES UNDERSTAND THE FUEL SAFETY SECTION OR CALL THE CUSTOMER ASSISTANCE HOTLINE AT 1-800-235-5878.

GASOLINE

The two-cycle engine on this product requires a fuel mixture of regular unleaded gasoline and a high quality 40:1 2-cycle engine oil (AIR-COOLED) for lubrication of the bearings and other moving parts. The correct fuel/oil mixture is 40:1 (see Fuel Mixture Chart). Too little oil or the incorrect oil type will cause poor performance and may cause the engine to overheat and seize.

Gasoline and oil must be premixed in a clean approved fuel container. Always use fresh regular unleaded gasoline.

This engine is certified to operate on unleaded gasoline.

IMPORTANT: Experience indicates that alcohol blended fuels called gasohol (or using ethanol or methanol) can attract moisture, which leads to oil/gas separation and formation of acids during storage. Acidic gas can damage the fuel system of an engine while in storage. To avoid engine problems, the fuel system should be emptied before storage for 30 days or longer. Drain the gas tank, then run the fuel out of the carburetor and fuel lines by starting the engine and letting it run until it stops. Use fresh fuel next season. See STORAGE instructions for additional information. Never use engine or carburetor cleaner products in the fuel tank or permanent damage may occur.

FUEL STABILIZER

Fuel stabilizer is an acceptable alternative in minimizing the formation of fuel gum deposits during storage. Add stabilizer to gasoline in fuel tank or storage container. Always follow the fuel mix ratio found on the stabilizer container. Run engine at least 5 minutes after adding stabilizer to allow the stabilizer to reach the carburetor. You do not have to drain the fuel tank for storage if you are using fuel stabilizer.

CRAFTSMAN 40:1 2-cycle engine oil (AIR-COOLED) is specially blended with fuel stabilizers. If you do not use this Sears oil, you can add a fuel stabilizer (such as CRAFTSMAN No. 33500) to your fuel tank.

40:1 2-CYCLE AIR-COOLED ENGINE OIL

CRAFTSMAN 40:1 2-cycle engine oil (AIR-COOLED) is strongly recommended. This oil is specially blended with fuel stabilizers for increased fuel stability (extends fuel life up to 5 times longer) and reduced smoke.

If CRAFTSMAN 2-cycle engine oil (AIR-COOLED) is not available, use a good quality 2-cycle engine oil (AIR-COOLED) that has a recommended fuel mix of 40:1.

IMPORTANT! Do not use:

- AUTOMOTIVE OIL
- BOAT OILS (NMMA, BIA, etc.)

These oils do not have proper additives for 2-cycle engines (AIR-COOLED) and can cause engine damage.

GASOLINE AND OIL MIXTURE

Mix gasoline and oil as follows:

- Consult chart for correct quantities.
- Do not mix gasoline and oil directly in the unit's fuel tank.

FOR ONE GALLON:

- Pour 3.2 ounces of high quality, 2-cycle engine oil (AIR-COOLED) into any empty, approved one gallon gasoline container.
- Add one gallon of regular unleaded gasoline to the gallon container, then securely replace the cap.
- Shake the container.
- The mixture is now ready for use. Fuel stabilizer can be added at this time if desired; follow mixing instructions on the label.

FUEL MIXTURE CHART

40:1 Fuel:Oil Mix Ratio

Gasoline	Oil (fl. oz.)
1 gallon	3.2
2.5 gallons	8.0

NOTE: Fuel containers may hold more than the specified amount. If too much gasoline is in the container, the resulting gas-to-oil fuel mixture will not be correct for proper engine operation.

OPERATION

STOPPING YOUR ENGINE

- Move the momentary switch to the OFF position. Do not release until the engine has completely stopped.
- If the engine does not stop, move the choke lever to the full choke.



WARNING:
THE SEMI-AUTOMATIC HEAD WILL TURN WHEN THE ENGINE STARTS.

FOR SAFE STARTING AND OPERATION, FOLLOW ALL SAFETY PRECAUTIONS IN THIS OPERATOR'S MANUAL AND LABELS ON THE UNIT. DRESS PROPERLY BEFORE STARTING ENGINE.

AVOID ANY CONTACT WITH THE MUFFLER. A HOT MUFFLER CAN CAUSE SERIOUS BURNS.

BASIC STARTING PROCEDURE (Fig. 8 & 9)

COLD ENGINE START AND WARM ENGINE START AFTER RUNNING OUT OF FUEL

- Fuel engine with 40:1 fuel mix (3.2 oz. to 1 gal. gas). Move 10 feet (3 meters) away from fueling site.
- Move momentary switch to the ON position.

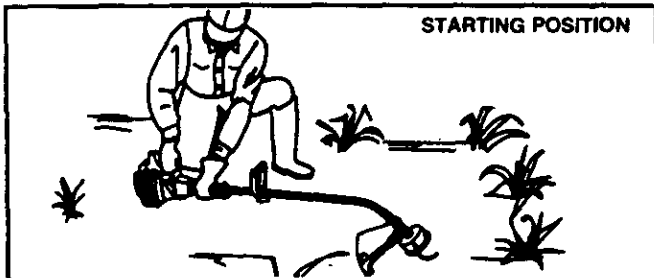

Figure 8

- Prime engine by pressing primer bulb six times.
- Actuate choke by moving the choke lever to the "Full Choke" position.
- Rest engine and debris shield on ground, supporting semi-automatic head off ground.
- Squeeze and hold the throttle trigger. *Keep the throttle trigger fully squeezed until the engine runs smoothly.*

NOTE: When pulling the starter rope, do not use the full extent of the rope as this can cause the rope to break. Do not let the starter snap back. Hold the handle and let the rope rewind slowly.

- Pull starter rope sharply five times.

The engine may sound as if it is trying to start before the fifth pull. If so, go to the next step immediately.

- Move the choke lever to the "Half Choke" position.
- Pull the starter rope sharply until the engine runs, but no more than six pulls.

Once the engine starts, allow the engine to run 10 seconds, then move the choke lever to "Off Choke." Allow the engine to run for 30 more seconds at "Off Choke" before releasing the throttle trigger.

NOTE: If the engine has not started after 6 pulls (at half choke), check to make sure the choke lever is in the proper position. Then, move the choke lever to the full choke position and press the primer bulb 6 times; pull the starter rope 2 more times. Move the choke lever to half choke and pull the starter rope until the engine runs, but no more than 6 more pulls.

NOTE: If engine still has not started, it is probably flooded. Proceed to "Difficult Starting and Flooded Engine."

- Allow the engine to run 10 seconds, then move the choke lever to off choke. Allow the unit to run for 30 more seconds at "Off Choke," then release the throttle trigger.

NOTE: If engine dies with the choke lever at the "Off Choke" position, move the choke lever to half choke and pull the rope until the engine runs. Allow the unit to run for 30 more seconds at "Off Choke," then release the throttle trigger.

- To stop the engine, push and hold the momentary switch in the "Off" position; do not release until the engine has completely stopped.

STARTING A WARM ENGINE

- Move choke lever to the "Off Choke" position.
- Squeeze throttle trigger.
- Pull starter rope until engine starts.

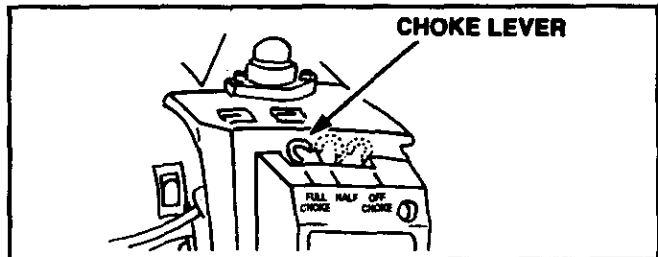

Figure 9

DIFFICULT STARTING OR FLOODED ENGINE

The engine may be flooded with too much fuel if it has not started after 20 pulls.

Flooded engines can be cleared of excess fuel with the following procedure:

- Move the choke lever to the "Off Choke" position.
- Squeeze and hold the throttle trigger.
- Pull starter rope handle until engine starts.

Starting could require pulling starter rope handle many times depending on how badly unit is flooded.

If engine still fails to start, refer to "TROUBLE SHOOTING" chart or call the 1-800 number listed on the front cover of this manual.

OPERATION

LINE TRIMMER TIPS (Fig. 10)



WARNING
USE MINIMUM SPEED AND DO NOT CROWD THE LINE WHEN CUTTING AROUND HARD OBJECTS (ROCK, GRAVEL, FENCE POSTS, ETC.) WHICH CAN DAMAGE THE SEMI-AUTOMATIC HEAD, BECOME ENTANGLED IN THE OR BE THROWN CAUSING A SERIOUS HAZARD.

ALWAYS WEAR EYE PROTECTION. NEVER LEAN OVER THE SEMI-AUTOMATIC HEAD. ROCKS OR DEBRIS CAN RICHOCHET OR BE THROWN INTO EYES AND FACE AND CAUSE BLINDNESS OR OTHER SERIOUS INJURY.

- For trimming or scalping, use partial throttle to increase line life, especially:
 - during light duty cutting.
 - near objects around which the line can wrap or wear line such as small posts, trees, fence wire or concrete.
- The line will easily remove grass and weeds from around walls, fences, trees and flower beds; but, it also can cut the tender bark of trees or shrubs and scar fences and damage vinyl siding, above ground swimming pool metal skirting, etc. To help avoid damage especially to delicate vegetation or trees with tender bark, shorten line to 4-5 inches and use at partial throttle.
- The tip of the line does the cutting. You will achieve the best performance and minimum line wear by not crowding the line into cutting area.
- Always release throttle trigger and allow engine to return to idle speed when not cutting.
- Hold bottom of the semi-automatic head about 3 inches above ground and at an angle.

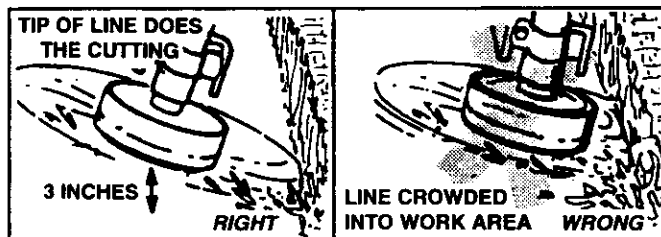

Figure 10

TECHNIQUES (Fig. 11, 12, 13 & 14)

- **TRIMMING** – Allow only the tip of the line to make contact. Do not force trimmer line into work area.

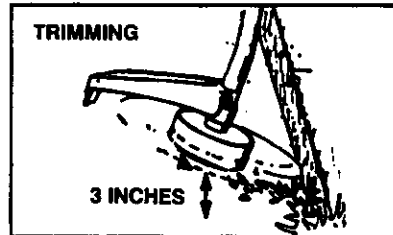

Figure 11

REMEMBER

Keep semi-automatic head 3 inches above the ground while trimming.

- **SCALPING** – The scalping technique removes unwanted vegetation. Allow the tip of the line to strike the ground around trees, posts, monuments, etc. *This technique increases line wear.*

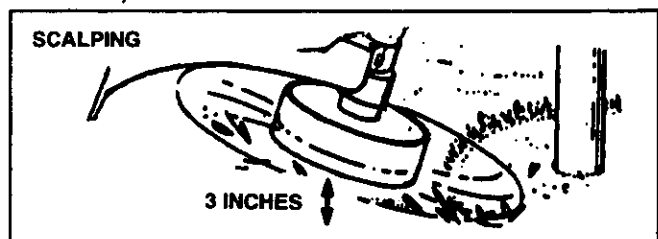

Figure 12

- **MOWING** – Your trimmer is ideal for mowing in places conventional lawn mowers cannot reach. Keep the line parallel to the ground.

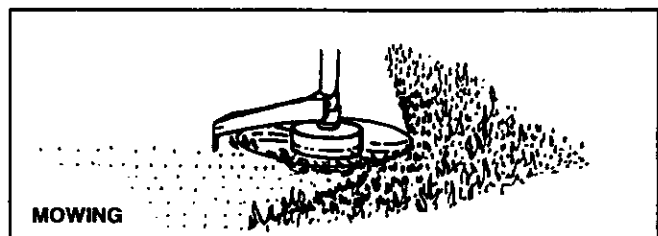

Figure 13

- **SWEEPING** – The fanning action of the rotating line can be used for a quick and easy clean up. Keep the line parallel to and above the surfaces being swept and move unit from side to side.

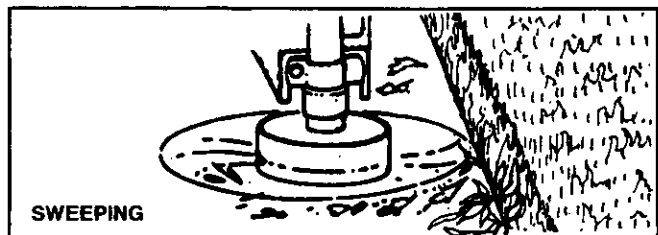

Figure 14

CUSTOMER RESPONSIBILITIES

MAINTENANCE SCHEDULE

Fill in dates as you complete regular service	Before Use	After Use	Every 5 Hrs.	Every 25 Hrs.	Yearly	Service Dates
Check for damaged or worn parts	✓					
Check for loose fasteners & parts	✓					
Clean unit & labels		✓				
Clean air filter			✓			
Clean/Inspect Spark Arrestor Screen (if installed) and Muffler				✓		
Drive Shaft Lubrication				✓		
Replace spark plug					✓	
Replace fuel filter					✓	

GENERAL RECOMMENDATIONS

The warranty on this unit does not cover items that have been subjected to operator abuse or negligence. To receive full value from the warranty, the operator must maintain unit as instructed in this manual.

Some adjustments will need to be made periodically to properly maintain your unit.

All adjustments in the "Service and Adjustments" section of this manual should be checked at least once each season.

- Once a year, replace the spark plug, replace air filter element and check semi-automatic head for wear. A new spark plug and a new air filter element assures proper air-fuel mixture and helps your engine run better and last longer.
- Follow the maintenance schedule in this manual.



WARNING
DISCONNECT THE SPARK PLUG BEFORE PERFORMING MAINTENANCE EXCEPT FOR CARBURETOR ADJUSTMENTS.

REPLACE SEMI-AUTOMATIC HEAD PARTS THAT ARE CRACKED, CHIPPED, OR DAMAGED IN ANY OTHER WAY BEFORE USING THE UNIT.

INSPECT THE ENTIRE UNIT. REPLACE DAMAGED PARTS. CHECK FOR FUEL LEAKS AND MAKE SURE ALL FASTENERS ARE IN PLACE AND SECURELY FASTENED.

BEFORE EACH USE

CHECK FOR DAMAGED OR WORN PARTS

- Semi-automatic head – replace semi-automatic head parts that are bent, warped, cracked, or damaged in any way.
- Fuel cap – replace broken or leaking fuel cap.
- Debris shields – replace debris shields that are bent, warped, cracked, or damaged in any way.
- Line limiter – missing or damaged.

CHECK FOR LOOSE FASTENERS AND PARTS

- Semi-automatic head
- Assist handle
- Throttle handle
- Cylinder cover and rear shroud
- Air filter cover
- Muffler
- Line Limiter

AFTER USE

CLEAN UNIT AND LABELS

- Clean the unit using a damp cloth with a mild detergent.
- Wipe off the unit with a clean dry cloth.

LUBRICATION CHART

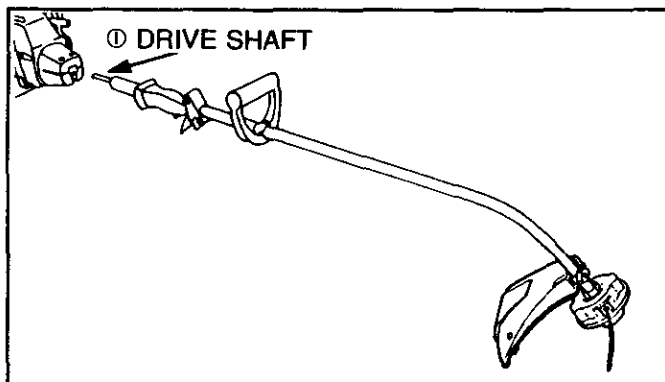

① General purpose lithium base grease.

CUSTOMER RESPONSIBILITIES

EVERY 5 HOURS CLEAN AIR FILTER (Fig. 15)

A dirty air filter decreases the life and performance of the engine and increases fuel consumption and harmful emissions.

Always clean after 5 tanks of fuel or 5 hours of operation. Clean more frequently in dusty conditions.

- Loosen the screws on the air filter cover enough to remove the cover from the engine.
- Remove air filter from cover.
- Wash filter in warm soapy water. We recommend a mild solution of dish washing liquid.
- Rinse air filter thoroughly in clean water.
- Squeeze air filter dry and replace in cover.
- Re-install the air filter cover, making sure the choke exit slot is placed over the choke lever.

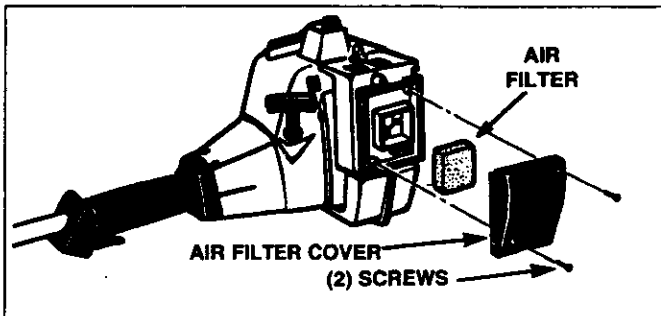

Figure 15

EVERY 25 HOURS CLEAN AND INSPECT SPARK ARRESTOR SCREEN (Fig. 16)

As the unit is used, carbon deposits build up on the muffler and spark arrestor screen (if installed), and must be removed to avoid creating a fire hazard or affecting engine performance.

Required cleaning is every 25 hours of operation or annually, whichever is less.

Replace the spark arrestor screen if breaks occur.

CLEANING THE SPARK ARRESTOR SCREEN

- Loosen and remove the five rear shroud screws.
- Remove the rear shroud.
- Remove the muffler cover retaining springs.
- Remove muffler diffuser and spark arrestor screen assembly. Notice the orientation of these parts for reassembly.
- Clean the spark arrestor screen with a wire brush or replace if breaks are found in the screen.
- Replace any broken or cracked parts.
- Reinstall diffuser and spark arrestor screen assembly.
- Reinstall muffler cover and the two muffler cover retaining springs.
- Reinstall rear shroud and the five rear shroud screws (15-20 in.lbs.).

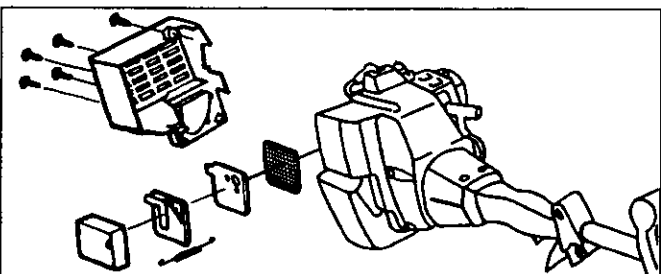

Figure 16

DRIVE SHAFT LUBRICATION (Fig. 17)

- Loosen the nose cone screws.
- Remove the tube from the nose cone.
- Remove the drive shaft from the tube.
- Check drive shaft for broken wires, twists or kinks, and replace if damage is found.
- Using a clean cloth, wipe surface of drive shaft thoroughly to remove any grease or dirt.
- Apply a uniform coat of lithium base grease to the entire surface of the drive shaft.
- Inject the remaining contents of the grease tube into the top of the tube.
- Replace drive shaft in the tube.
- Re-assemble the gear box to the tube. Tighten screws securely.

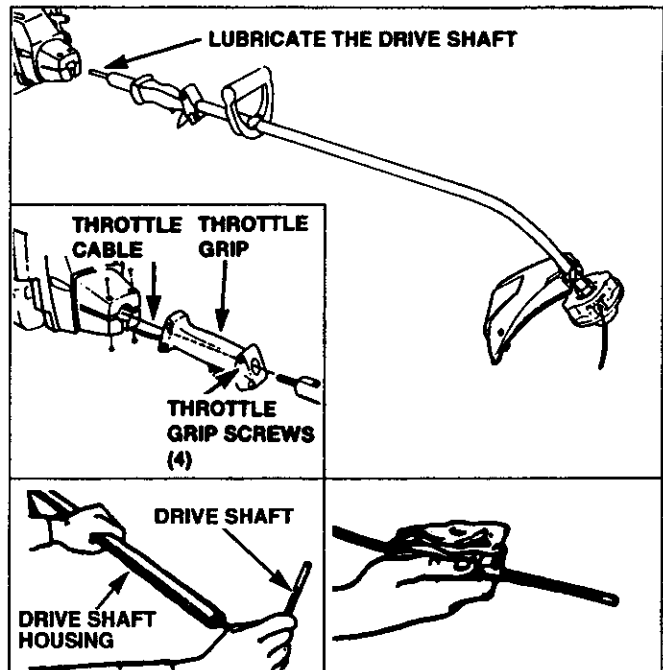

Figure 17

YEARLY REPLACE SPARK PLUG (Fig. 18)

The spark plug should be replaced each year to ensure the engine starts easier and runs better. Spark plug gap should be .025".

- Twist, then pull of spark plug boot.
- Remove spark plug from cylinder and discard.
- Replace with correct spark plug and re-tighten with spark plug wrench (10-12 ft.lb.).
- Reconnect spark plug boot.

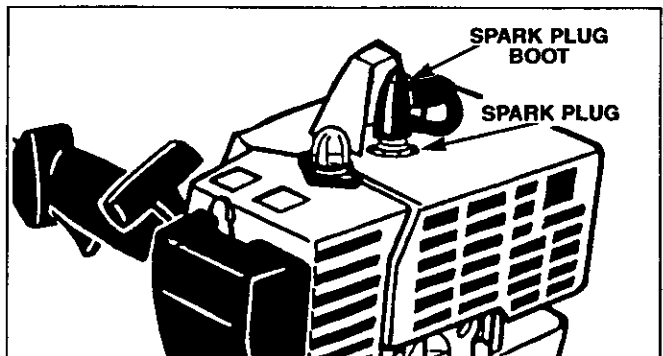

Figure 18

CUSTOMER RESPONSIBILITIES

REPLACE FUEL FILTER (Fig. 19 & 20)

The fuel filter should be replaced after each season. Never operate your unit without a fuel filter. Be careful not to damage fuel line while removing the fuel filter.

- Run fuel tank dry of fuel before proceeding with this step.
- Remove fuel cap and allow it to hang to side of motor.
- Using a small pair of needle nose pliers, grasp fuel cap retainer, holding it in tank opening and pull out.
- With cap out of tank, use a small section of bent wire similar to that shown in the illustration to catch fuel line and slowly pull from tank. When fuel filter appears in opening, grasp with fingers and remove from tank.
- Once filter is out of tank, hold fuel line close to fuel filter. Remove fuel filter by twisting and pulling at the same time.
- Replace fuel filter.
- Reverse process for installation.

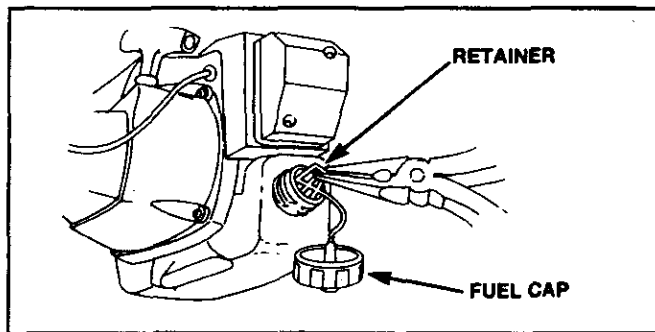

Figure 19

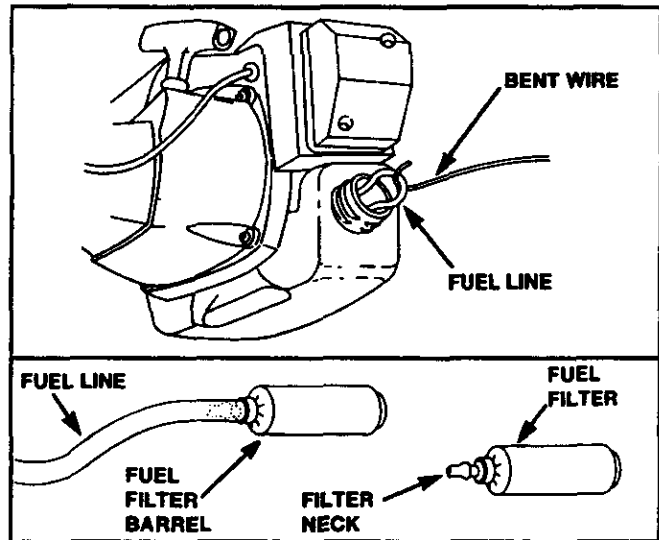

Figure 20

SERVICE AND ADJUSTMENTS

LINE REPLACEMENT



WARNING:
TRIMMER HEAD PARTS THAT ARE CHIPPED, CRACKED, BROKEN, OR DAMAGED IN ANY OTHER WAY CAN FLY APART AND CAUSE SERIOUS INJURY. DO NOT USE. REPLACE DAMAGED PARTS BEFORE USING THE UNIT.

THE LINE SAVER MUST BE INSTALLED ONLY FROM THE INSIDE OF THE HUB. IF INSTALLED ON THE OUTSIDE OF THE HUB, THE LINE SAVER CAN FLY OFF AND BECOME A DANGEROUS MISSILE.

USE ONLY .080" DIAMETER GOOD QUALITY LINE. NEVER USE WIRE, ROPE, STRING, ETC.

USE ONLY SPECIFIED SEARS REPLACEMENT PARTS. USE OF OTHER BRANDS OF REPLACEMENT PARTS CAN CAUSE DAMAGE TO YOUR UNIT OR INJURY TO THE OPERATOR OR OTHERS.

DAMAGE/INJURY CAUSED BY USE OF ACCESSORIES/ATTACHMENTS NOT SPECIFICALLY RECOMMENDED BY SEARS WILL NOT BE REIMBURSED.

IMPORTANT: ALWAYS CLEAN DIRT AND DEBRIS FROM SPOOL AND HUB WHEN PERFORMING ANY TYPE MAINTENANCE.

INSTALLING PRE-WOUND SPOOL (Fig. 21, 22, 23, 24, & 25)

- Hold the semi-automatic head as shown. Press the two lock tabs and remove cover. Figure 21.
- Remove the lock ring, tap button, and spool.
- Clean dirt and debris from all parts. Replace the spool when the square corners on the lugs are rounded off, reduced in size, or broken off. Figure 22.
- Find "THIS SIDE UP" on spool and catch the line in the notch in the bottom ring of the spool, leaving about 4 inches of line hanging from the spool.
- Insert the end of the line through the line exit hole.
- Align the line and notch with the line exit hole. Place spool in hub. Make sure trimmer line is not caught between the rim of the spool and the hub.

NOTE: To set the spool in the hub, it may be necessary to pull the line through the line exit hole until the spool drops into place.

- Align the lock tabs on the cover over the catches on the hub. Push the cover down onto the hub until the parts snap together.
- Check to make sure the lock tabs are properly fastened as shown.
- Obtain the correct line length (4-6 inches) by pressing the tap button and pulling on the line again. Approximately 2 inches of line can be pulled each time the tap button is pressed.

NOTE: If tap button gets knocked out of the hub, reassemble parts as follows:

- Remove the cover and spool.
- Place the spring in the hub cylinder.
- Place the tap button over the spring and hub cylinder.
- Align the slots in the tap button with the fins in the base of the hub. Push parts together.
- Reinstall the spool and cover.

INSTALLING NEW LINE ON SPOOL (Fig. 26)

To replace the line on existing spool:

- Follow "Installing Spool with Line Already Wound" steps and remove any line remaining on the spool.
- Use a 25 foot length of SEARS .080" diameter line.
- Insert about 1/4 inch of the end of the line through the hole in the top or rim of the spool. Allow no more than 1/4 inch of line to extend beyond the rim to avoid interference with tapping action.
- Wrap the line on the spool as shown by the arrow.

NOTE: The line must be wrapped firmly and evenly for proper line feed.

- Follow "Installing Spool with Line Already Wound" steps to complete assembly.
- If line breaks off or backs up in the semi-automatic head, follow "Installing Spool with Line Already Wound" steps. Pull slack in line until the line is tightly wound on spool, leaving 4-6 inches of extended line.

INSTALLING THE SPOOL

- Insert line into line exit hole in the hub as shown. Figure 23.
- Align the line and notch with the line exit hole.
- Push spool into the hub until it snaps into place.
- Pull the end of the line to seat spool in hub.
- Reinstall the cover.

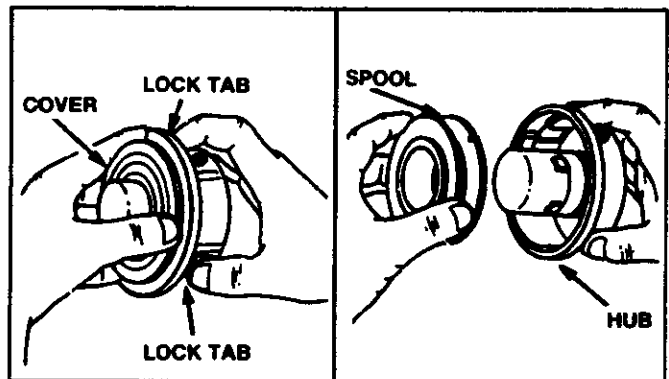

Figure 21

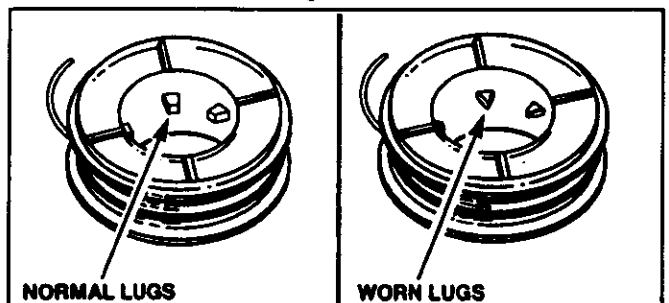

Figure 22

SERVICE AND ADJUSTMENTS

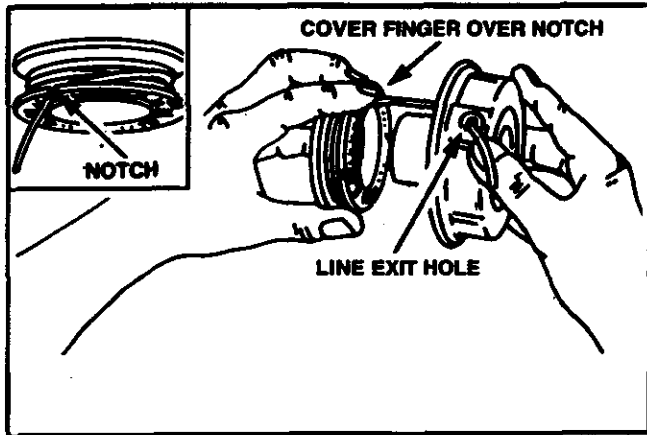

Figure 23

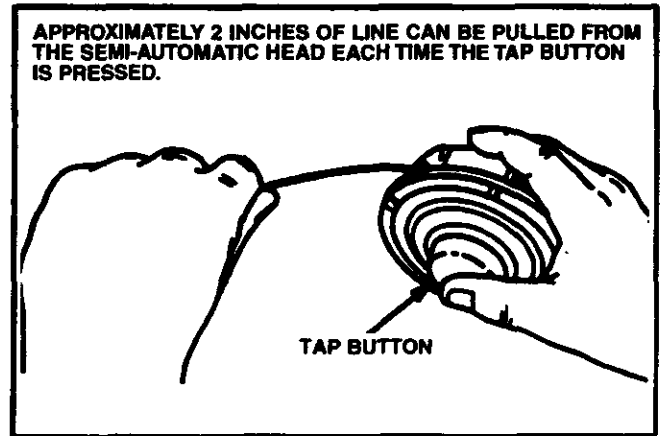

Figure 25

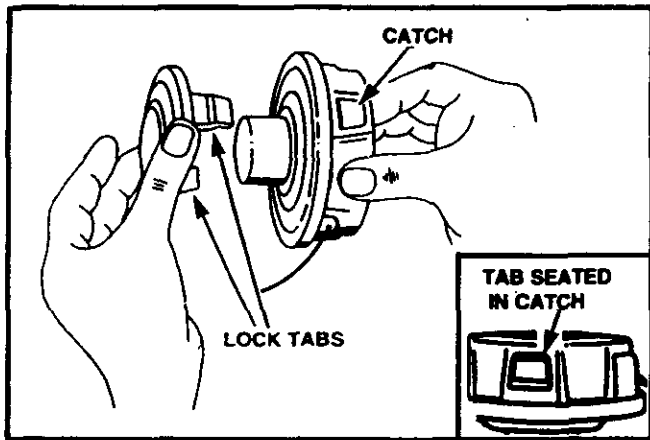

Figure 24

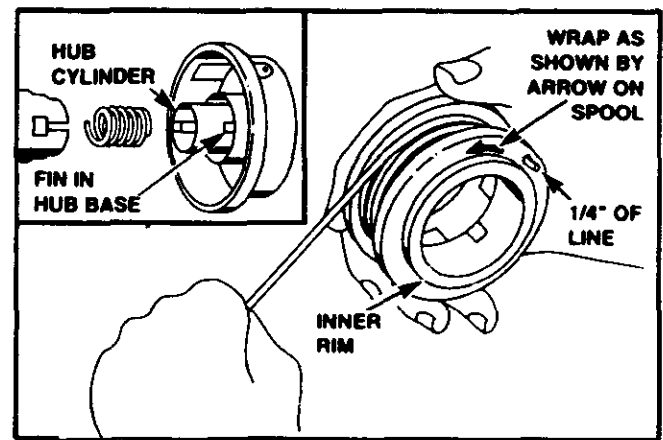

Figure 26

SERVICE AND ADJUSTMENTS

Carburetor adjustment is critical and if done improperly can permanently damage the engine as well as the carburetor. Please read all instructions and consult the Troubleshooting section of this manual before beginning this process. If the engine does not operate according to these instructions after repeating the adjusting steps, do not use the unit. For further assistance, please call our customer assistance hotline at 1-800-235-5878.

WARNING:
MAKE CARBURETOR ADJUSTMENTS WITH THE LOWER END SUPPORTED TO PREVENT SEMI-AUTOMATIC HEAD FROM CONTACTING ANY OBJECT. HOLD UNIT WITH YOUR HAND.

THE SEMI-AUTOMATIC HEAD WILL BE SPINNING DURING MOST OF THIS PROCEDURE. WEAR YOUR PROTECTIVE EQUIPMENT AND OBSERVE ALL SAFETY PRECAUTIONS.

IN MIXTURE ADJUSTMENT, RECHECK IDLE SPEED AFTER EACH ADJUSTMENT. THE SEMI-AUTOMATIC HEAD MUST NOT MOVE AT IDLE SPEED.

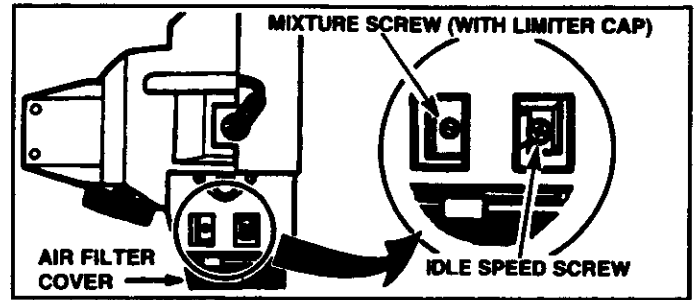

Figure 27

ADJUSTING PROCEDURE

IDLE SPEED ADJUSTMENT

- Allow the warm engine to idle.
- Adjust the Idle Speed until the engine continues to run without stalling and without the semi-automatic head turning.
 - Turn screw clockwise to increase engine speed if engine stalls or dies.
 - Turn screw counterclockwise to slow engine down.
- Follow instructions in "Acceleration Check".
- No further adjustments are necessary if performance is satisfactory.

MIXTURE ADJUSTMENT

- Support the lower end so the semi-automatic head is off the ground and will not make contact with any object. Be sure the trimmer line is extended to the maximum length allowed by the line limiter.
- Start the engine. Allow engine to idle, then squeeze throttle trigger fully.

NOTE: Perform steps below at full throttle.

- Turn mixture screw counterclockwise to the limiter cap stop.
- Run engine at full throttle for 30 seconds.
- If engine is running rough, turn mixture screw clockwise in 1/16th turn increments until engine just starts to run smoothly.
- Do not attempt to adjust screw beyond stops as damage will occur.
- After completing adjustments, check for acceleration.
- If the unit accelerates and runs smoothly, no further adjustments are necessary. If not, proceed to "Acceleration Check".

ACCELERATION CHECK

- Allow engine to idle.
- Squeeze trigger fully.
 - If performance is satisfactory (engine accelerates smoothly), no further adjustments are necessary.
 - If the engine does not accelerate smoothly, turn the mixture screw counterclockwise a small amount (no more than the width of the slot in the adjusting screw).
- Repeat step above until smooth acceleration is obtained. Do not attempt to adjust the screw beyond the stop as damage will occur.

NOTE: It may be necessary to repeat "Idle speed Adjustment" through "Acceleration Check," to obtain correct adjustments.

If engine does not start, it may be flooded. If in doubt read the section on flooded engine in the starting section of this manual prior to beginning any adjustments.

The carburetor has been adjusted at the factory for sea level conditions. Adjustments may become necessary if the unit is used at significantly higher altitudes or if you notice any of the following conditions:

- Engine will not idle. See "Idle Speed Adjustment" and "Mixture Speed Adjustment".
- Engine dies or hesitates when it should accelerate. See "Acceleration Check".
- Loss of cutting power which is not corrected by air filter cleaning. See "Mixture Speed Adjustment".

NOTE: There are two adjustments on the carburetor.

- The Idle Speed Adjustment.
- The Mixture Adjustment.

CARBURETOR PRESETS (Fig. 27)

If your engine will not start due to suspected improper carburetor adjustment, the following presets may be required. If used, it is recommended that all steps within the adjustment procedure be completed in order to assure a properly set carburetor. If presets are not needed, proceed to section "Idle Speed Adjustment".

When making adjustments, be careful not to force the plastic limiter caps beyond the stops or damage will occur.

Very small adjustments can affect engine performance. It is important to make slight adjustments and test performance before proceeding. Each adjustment should be no more than 1/16th of a turn.

- Turn the mixture adjustment fully counterclockwise to the limiter cap stops.
- Turn idle speed adjustment clockwise one full turn.
- If engine fails to start after performing carburetor presets, the unit may be flooded. Review the "Difficult Starting" section of the manual. If problems continue, call the 1-800 number listed on the front cover of this manual for further assistance.
- Start the engine and operate for three (3) minutes to warm up. Go to "Adjusting Procedure".

STORAGE

Immediately prepare your unit for storage at the end of the season or if it will not be used for 30 days or more.



WARNING:

ALLOW THE ENGINE TO COOL, AND SECURE THE UNIT BEFORE STORING OR TRANSPORTING IN A VEHICLE.

STORE UNIT AND FUEL IN AN AREA WHERE FUEL VAPORS CANNOT REACH SPARKS OR OPEN FLAMES FROM WATER HEATERS, ELECTRIC MOTORS OR SWITCHES, FURNACES, ETC.

STORE UNIT WITH ALL GUARDS IN PLACE. POSITION SO THAT ANY SHARP OBJECT CANNOT ACCIDENTALLY CAUSE INJURY TO PASSER BY.

STORE THE UNIT OUT OF THE REACH OF CHILDREN.

GAS TRIMMER STORAGE INSTRUCTIONS

If your trimmer is to be stored for a period of time, clean it thoroughly prior to storage. Remove any dirt, leaves, oil, grease, etc. Store in a clean dry area.

- Clean the entire unit.
- Clean air filter. Refer to "Customer Responsibilities".
- Open the semi-automatic head assembly and clean any dirt, grass or debris that has collected.
- Inspect the cutting line. Old cutting line may be chalky or sticky to the touch. Remove and discard old line and install fresh new line.
- Lightly oil external metal surfaces to prevent rust from forming.
- Re-assemble all loose parts, being sure that all handles and guards are in place and are securely fastened. Replace any damaged parts.
- The recommended storage position is either vertically with the fuel cap on top, or horizontally with the fuel cap up. **Do not store unit with the cutting attachment up, above the engine.**
- The unit can be hung by the drive shaft housing so that the line limiter cannot cause injury.



CAUTION: Wear protective gloves when handling Line Limiter. The blade is sharp and can cut you.

FUEL SYSTEM

Never use engine or carburetor cleaner products in the fuel tank or permanent damage may occur to fuel system components.

Follow these instructions:

- Drain the fuel from the unit into an approved fuel container.
- Drain the fuel lines and carburetor by starting the engine and letting it run until it stops.
- Allow the engine to cool before storage.

IMPORTANT: It is important to prevent gum deposits from forming in essential fuel system parts such as the carburetor, fuel filter, fuel hose or tank during storage. Also, experience indicates that alcohol blended fuels, those that use ethanol or methanol (called gasohol or oxygenated fuel), can attract moisture and form acidic gas which will damage your engine. To avoid engine problems, the fuel system should be emptied before storage of 30 days or longer.

Fuel stabilizer is an acceptable alternative in minimizing the formation of fuel gum deposits during storage. Add stabilizer to the gasoline in the fuel tank or fuel storage container. Always follow the mix instructions found on stabilizer container. Run engine at least 5 minutes after adding stabilizer to allow the stabilizer to reach the carburetor.

CRAFTSMAN 40:1 2-cycle engine oil (AIR-COOLED) is specially blended with fuel stabilizers. If you do not use this Sears oil, you can add a fuel stabilizer (such as CRAFTSMAN No. 33500) to your fuel tank.

INTERNAL ENGINE

- Remove spark plug and pour 1 teaspoon of 40:1 oil through the spark plug opening. Slowly pull the starter rope 8 to 10 times to distribute oil to inner engine surfaces.
- Replace spark plug with a new one of the recommended type and heat range. Refer to "Product Specifications".
- Clean air filter. Refer to "Customer Responsibilities".
- Reinstall all covers and hardware removed for access; tighten all screws and fasteners.
- Check entire unit for loose screws, nuts, and bolts. Replace any damaged, broken, or worn parts.
- Lightly oil external metal surfaces to prevent rust from forming.
- Use fresh fuel having the proper gasoline to oil ratio at the beginning of the next season.

OTHER

- Do not store gasoline from one season to another.
- Replace your gasoline can if your can starts to rust. Rust and/or dirt in your fuel system will cause problems.
- Store your unit in a well ventilated area and covered, if possible, to prevent dust and dirt accumulation. Do not cover with plastic. Plastic cannot breathe and will induce condensation and eventual rust or corrosion.

IMPORTANT: Never cover unit while engine and exhaust areas are still warm.

TROUBLE SHOOTING POINTS

TROUBLE SHOOTING CHART

SYMPTOM	CAUSE	CORRECTION
Engine will not start or will run only for a few seconds after starting.	<ol style="list-style-type: none"> 1. Fuel tank empty. 2. Engine flooded. 3. Spark plug not firing. 4. Fuel not reaching carburetor. 5. Carburetor requires adjustment. 6. None of the above. 	<ol style="list-style-type: none"> 1. Fill tank with correct fuel mixture. 2. See "Starting Instructions" 3. Install new plug/check ignition switch. 4. Replace fuel filter; inspect fuel line. 5. See "Carburetor Adjustments." 6. Contact your SEARS Service Center/Dept.
Engine will not idle properly.	<ol style="list-style-type: none"> 1. Carburetor set too fast or too slow. 2. Carburetor requires adjustment. 3. None of the above. 	<ol style="list-style-type: none"> 1. See "Carburetor Adjustments." 2. See "Carburetor Adjustments." 3. Contact your SEARS Service Center/Dept.
Engine will not accelerate, lacks power, or dies under a load	<ol style="list-style-type: none"> 1. Air filter dirty. 2. Spark plug fouled. 3. Carburetor requires adjustment. 4. Muffler outlets plugged. 5. None of the Above. 	<ol style="list-style-type: none"> 1. Clean or replace air filter. 2. Clean or replace spark plug and re-gap. 3. See "Carburetor Adjustments." 4. Contact your SEARS Service Center/Dept. 5. Contact your SEARS Service Center/Dept.
Engine smokes excessively	<ol style="list-style-type: none"> 1. Air filter dirty. 2. Fuel mixture incorrect. 3. Carburetor requires adjustment. 	<ol style="list-style-type: none"> 1. Clean or replace air filter. 2. Refuel with correct fuel mixture. 3. See "Carburetor Adjustments."
Engine runs hot	<ol style="list-style-type: none"> 1. Fuel mixture incorrect. 2. Spark plug incorrect. 3. Carburetor set too low (Lean). 4. None of the above. 	<ol style="list-style-type: none"> 1. See "Fueling Your Unit." 2. Replace with correct plug. 3. See "Carburetor Adjustments." 4. Contact your SEARS Service Center/Dept.
Cutting Head stops under a load or does not turn when engine is accelerated.	<ol style="list-style-type: none"> 1. Drive shaft not engaged. 2. Drive shaft broken. 	<ol style="list-style-type: none"> 1. See "Assembly," "Tube", insert fully. 2. Contact your SEARS Service Center/Dept.
Line does not advance or breaks while cutting.	<ol style="list-style-type: none"> 1. Line improperly routed in head. 2. Line improperly wound onto spool. 3. Line size incorrect. 4. Old cutting line. 5. Too little line outside head. 6. Dirt accumulated on cover cut-outs. 7. Line wound in wrong direction. 	<ol style="list-style-type: none"> 1. Remove cover. Check line routing. 2. Rewind line tightly and evenly. 3. Use only .080" diameter line. 4. Replace with new cutting line. 5. Remove cover. Pull 4" of line to outside. 6. Clean cover cut-out. 7. Rewind in correct direction.
Line welds onto spool.	<ol style="list-style-type: none"> 1. Line size incorrect. 2. Old cutting line. 3. Incorrect spool. 4. Crowding line against material being cut. 5. Cutting at higher speed than necessary. 	<ol style="list-style-type: none"> 1. Use only .080" diameter line. 2. Replace with new cutting line. 3. Use proper spool. 4. Cut with tip of line. 5. Reduce cutting speed.
Line pulls back into head.	<ol style="list-style-type: none"> 1. Too little line outside of head. 2. Old cutting line. 	<ol style="list-style-type: none"> 1. Remove cover. Pull 4" of line to outside. 2. Replace with new cutting line.

*If situations occur which are not covered in this manual, use care and good judgement.
If you need assistance, contact your SEARS Service Center/Department or the
CUSTOMER ASSISTANCE HOTLINE at 1-800-235-5878*

REPAIR PARTS

SEARS WEEDWACKER - MODEL 358.798420

WARNING
All repairs, adjustments and maintenance not described in the Operator's Manual must be performed by qualified service personnel.

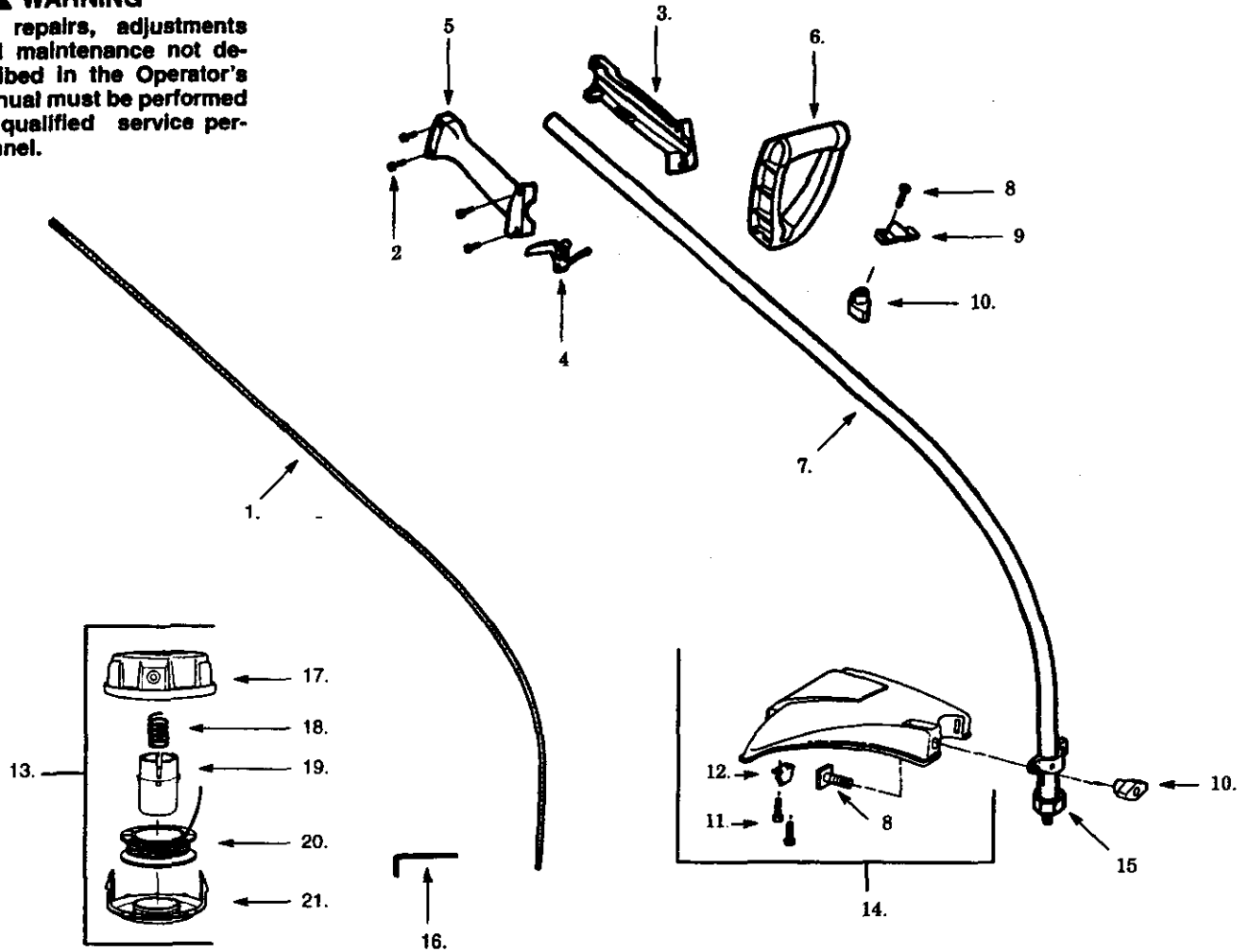

Ref.	Part No.	Description	Ref.	Part No.	Description
1.	530-095176	Drive Shaft-48"			
2.	530-015966	Screw			
3.	530-036514	Throttle Hsg. (Left)			
4.	530-038876	Throttle Lever			
5.	530-036515	Throttle Hsg. (Right)			
6.	530-094673	"D" Handle			
7.	530-095259	Drive Shaft Hsg.			
8.	530-015820	Bolt-Shield/Handle			
9.	530-094847	Clamp			
10.	530-016119	Knob			
11.	530-015886	Screw			
12.	530-095249	Line Limiter			
13.	71-85801	Cutting Head Ass'y. (Incl. 17-21)			
14.	530-069666	Shield Ass'y. (Incl. 11-12)			
15.	530-094543	Dust Cup			
16.	530-031159	Hex Wrench (5/32)			
17.	530-094875	Hub Ass'y.			
18.	530-094830	Spring			
19.	530-094827	Release Button			
20.	71-85811	Spool w/Line			
21.	530-094828	Cover			
				Not Shown	
				530-047314	Carton Contents Bag
				530-083344	Operator Manual
				530-029159	Shaft Warning Decal
				530-085220	Carton
				530-038875	Instruction Decal
				530-038716	Decal Shield

REPAIR PARTS

SEARS WEEDWACKER - MODEL 358.798420

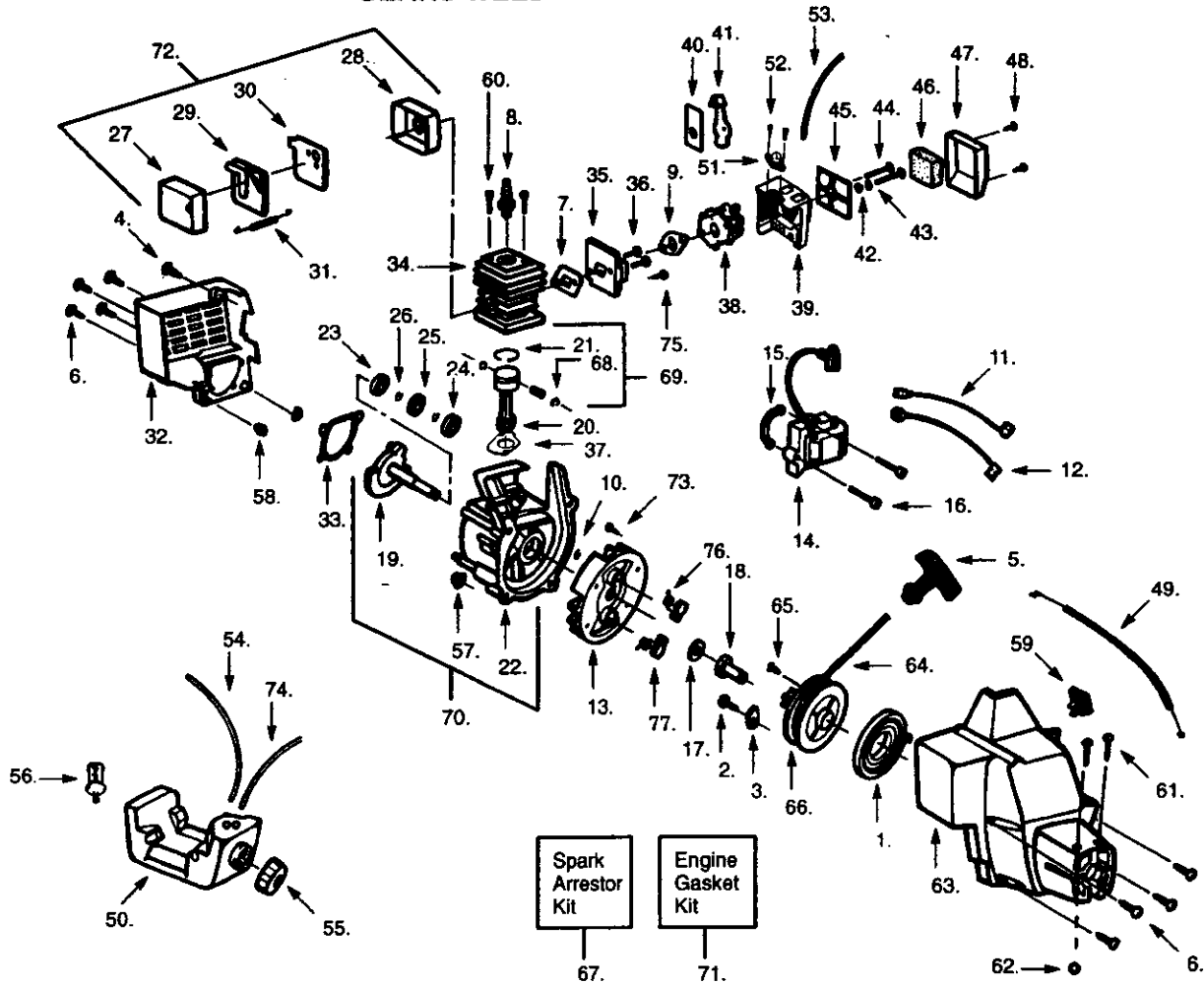

Ref.	Part No.	Description	Ref.	Part No.	Description	Ref.	Part No.	Description
1.	530-029395	Starter Spring	27.	530-036578	Muffler Body	53.	530-069216	Fuel Line-Primer/Carb
2.	530-015496	Screw-Pulley	28.	530-036577	Muffler Cover	54.	530-069247	Fuel Line-Carb/Tank
3.	530-027523	Retainer	29.	530-036802	Muffler Baffle-Exit	55.	530-014347	Fuel Cap Ass'y.
4.	530-015934	Screw-Shrd/Fan Hsg	30.	530-036579	Muffler Baffle-First	56.	530-014362	Fuel Pickup Ass'y.
5.	530-027569	Starter Handle	31.	530-029930	Muffler Spring	57.	530-036792	C'case Isolator
6.	530-015810	Screw-Fan Housing	32.	530-038871	Rear Shroud	58.	530-036793	Shroud Isolator
7. +	530-019185	Cylinder/Carb. Gasket	33. +	530-019181	Gasket-C'case	59.	530-038114	Switch
8.	STD PM2	Spark Plug-RCJ-8Y	34.	530-069619	Cylinder	60.	530-015953	Screw-Cylinder
9. +	530-019194	Gasket-Carb.Adaptor	35.	530-069564	Carb. Adaptor Kit	61.	530-016072	Screw-Pinch Clamp
10.	530-015945	Retainer-C'case	36.	530-016014	Screw-Carb. Adaptor	62.	530-015768	Locknut-Pinch Clamp
11.	530-014663	Lead Wire	37. +	530-019223	Gasket-Cylinder	63.	530-047315	Fan Hsg./Shroud Assy
12.	530-014662	Ground Wire	38.	530-069665	Carburetor Kit (Incl Limiter Caps)	64.	530-069232	Rope Kit
13.	530-039148	Flywheel Ass'y.	39.	530-038872	Air Box	65.	530-016080	Screw-Rope Retain.
14.	530-039163	Ignition Module	40.	530-037326	Choke Plate	66.	530-069400	Starter Pulley Kit
15.	530-036145	Spacer	41.	530-038873	Choke Shutter	67.	530-069380	Spark Arrestor Kit
16.	530-015954	Screw	42.	530-015254	Wave Washer	68.	530-015162	Piston Pin Retainer
17.	530-015828	Washer	43.	530-015852	Choke Spacer	69.	530-069621	Piston Kit
18.	530-027953	Drive Coupling	44.	530-015887	Screw-Filter Cover			(Incl. 21, 68 & Pin)
19.	530-014532	Crankshaft Ass'y.	45.	530-037413	Filter Plate	70.	530-014729	C'case & C'shaft Assy
20.	530-069615	Connecting Rod Assy.	46.	530-037331	Air Filter Foam			(Incl. 10,19,22-26)
21.	530-036404	Piston Ring	47.	530-037292	Air Filter Cover	71.	530-069625	Gasket Kit (+ Indic-ates Contents)
22.	530-014861	Crankcase Ass'y.(Incl. 10 & 23-25)	48.	530-015966	Screw-Air Filter			
23.	530-032125	Inner Bearing	49.	530-036744	Throttle Cable Ass'y.	72.	530-069389	Muffler Kit
24.	530-032124	Outer Bearing	50.	530-047221	Fuel Tank Ass'y.	73.	530-015882	Screw
25.	530-019179	C'case Seal	51.	530-038874	Primer Bulb Ass'y.	74.	530-069571	Fuel Line-Primer/Tank
26.	530-015941	Retaining Ring-C'shaft	52.	530-016090	Screw-Primer Bulb	75.	530-015814	Screw-Carb. Adaptor
						76.	530-029939	Starter Dog
						77.	530-037730	Spring-Starter Dog

REPAIR PARTS

SEARS WEEDWACKER - MODEL 358.798420

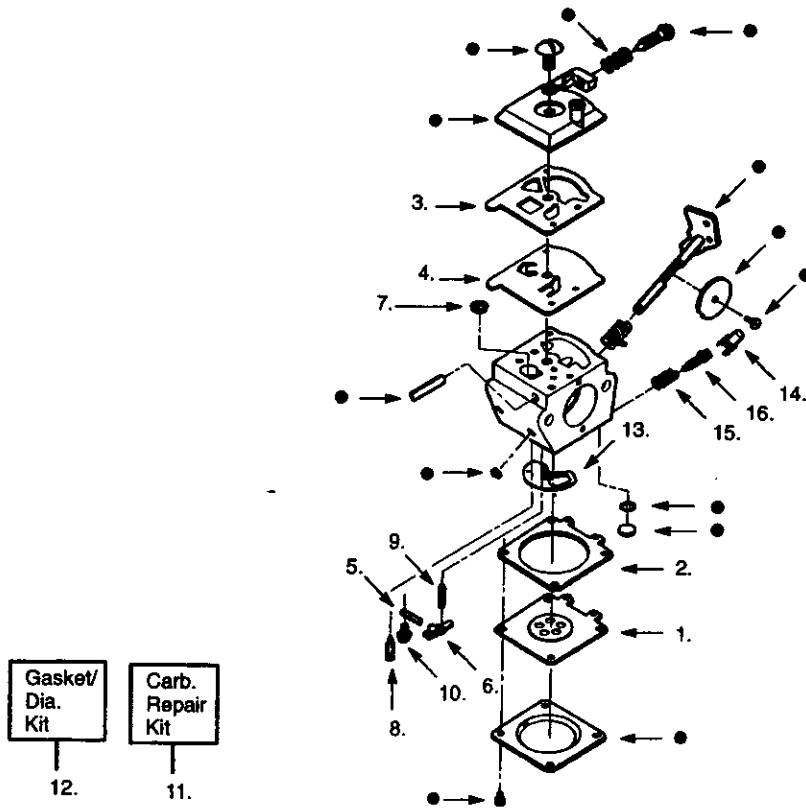

Ref.	Part No.	Description
1.	530-035014	Metering Diaphragm
2.	530-035001	Metering Diaphragm Gasket
3.	530-035164	Pump Gasket
4.	530-035166	Pump Diaphragm
5.	530-035028	Metering Lever Pin
6.	530-035031	Metering Lever
7.	530-035178	Fuel Inlet Screen
8.	530-035008	Inlet Needle Valve
9.	530-037330	Metering Lever Spring
10.	530-035016	Metering Lever Pin Screw
11.	530-069460	Carburetor Repair Kit
12.	530-069461	Gasket/Diaphragm Kit
13.	530-035211	Circuit Plate Gasket
14.	530-038404	Limiter Cap
15.	530-035342	Idle Needle Spring
16.	530-035341	Idle Needle

●= THESE PARTS ARE ILLUSTRATED FOR CLARITY. ORDER COMPLETE ASSEMBLY.

NOTES

SEARS

Operator's Manual

**Model No.
358.798420**

IF YOU NEED REPAIR SERVICE OR PARTS:

**REPAIR SERVICE
1-800-4-REPAIR
(1-800-473-7247)**

**ORDERING PARTS
1-800-FON-PART
(1-800-366-7278)**



**CUSTOMER
ASSISTANCE
1-800-235-5878**

**HOURS (CST)
Mon. - Sat. 7 a.m. - 7 p.m.
Sun. 10 a.m. - 7 p.m.**

CRAFTSMAN®

21 cc/1.3 cu. in. 2-CYCLE ENGINE 16 Inch Semi-Automatic Head® GAS WEEDWACKER®

Each Gas Weedwacker® has its own model number. The model number for your unit will be found on a decal attached to the unit.

All parts listed herein may be ordered from any Sears, Roebuck and Co. Service Center and most Retail Stores.

WHEN ORDERING REPAIR PARTS, ALWAYS GIVE THE FOLLOWING INFORMATION AS SHOWN IN THIS LIST:

- PRODUCT — "GAS WEEDWACKER"
- MODEL NUMBER — 358.798420
- PART NUMBER
- PART DESCRIPTION

Your Sears Merchandise has added value when you consider that Sears has service units nationwide staffed with Sears trained technicians... professional technicians specifically trained on Sears products, having the parts, tools and equipment to insure that we meet our pledge to you, we service what we sell.