

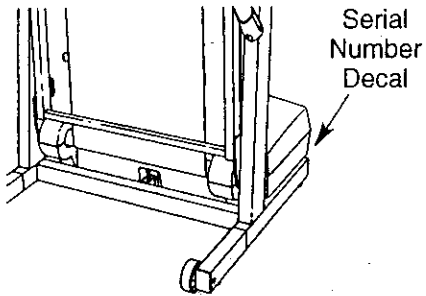

# CrossWalk 380x

Model No. 831.293040

Serial No. \_\_\_\_\_



## TREADMILL EXERCISER User's Manual

- Assembly
- Operation
- Maintenance
- Part List and Drawing

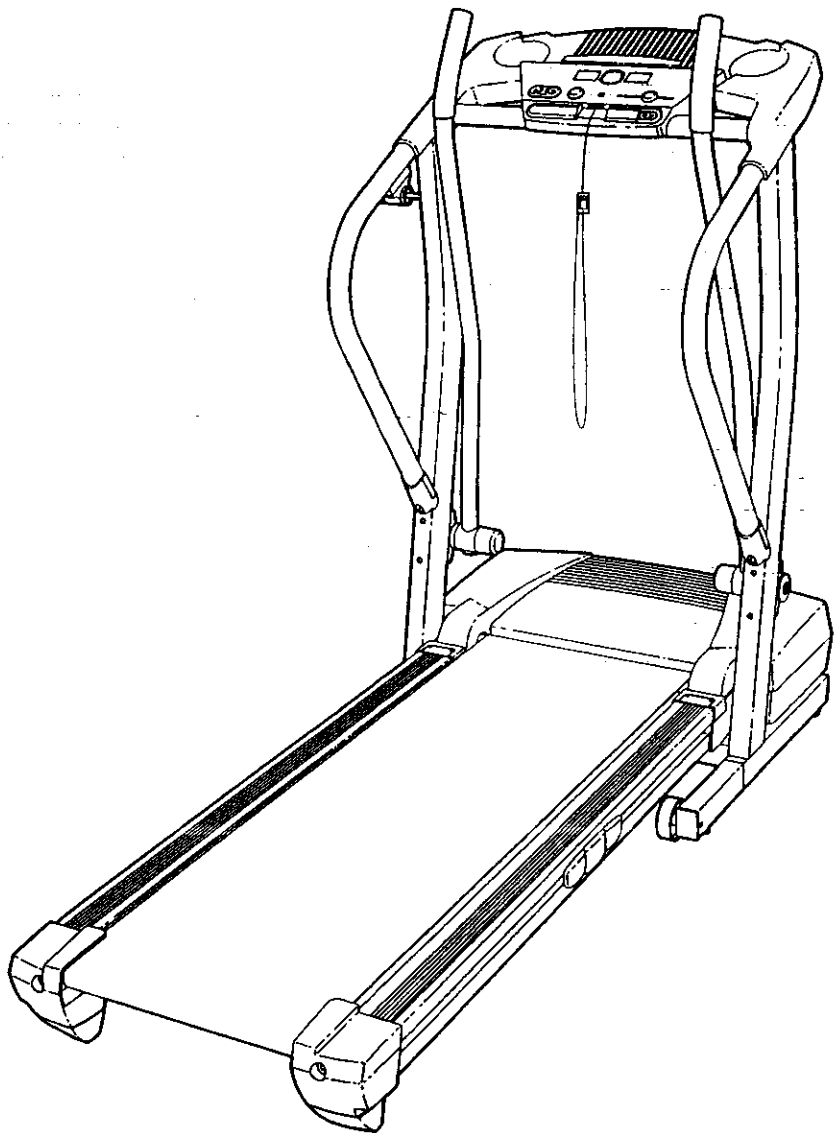

### **CAUTION**

Read all precautions and instructions in this manual before using this equipment. Save this manual for future reference.

Sears, Roebuck and Co., Hoffman Estates, IL 60179

# TABLE OF CONTENTS

IMPORTANT PRECAUTIONS .....	2
BEFORE YOU BEGIN .....	4
ASSEMBLY .....	5
OPERATION AND ADJUSTMENT .....	8
HOW TO FOLD AND MOVE THE TREADMILL .....	18
TROUBLESHOOTING .....	20
CONDITIONING GUIDELINES .....	22
ORDERING REPLACEMENT PARTS .....	Back Cover
FULL 90 DAY WARRANTY .....	Back Cover

Note: An EXPLODED DRAWING and a PART LIST are attached in the center of this manual.

## IMPORTANT PRECAUTIONS

**⚠ WARNING:** To reduce the risk of burns, fire, electric shock, or injury to persons, read the following important precautions and information before operating the treadmill.

1. It is the responsibility of the owner to ensure that all users of this treadmill are adequately informed of all warnings and precautions.
2. Use the treadmill only as described.
3. Place the treadmill on a level surface, with at least eight feet of clearance behind it and two feet on each side. Do not place the treadmill on any surface that blocks air openings. To protect the floor or carpet from damage, place a mat under the treadmill.
4. Keep the treadmill indoors, away from moisture and dust. Do not put the treadmill in a garage or covered patio, or near water.
5. Do not operate the treadmill where aerosol products are used or where oxygen is being administered.
6. Keep children under the age of 12 and pets away from the treadmill at all times.
7. The treadmill should be used only by persons weighing 250 pounds or less.
8. Never allow more than one person on the treadmill at a time.
9. Wear appropriate exercise clothes when using the treadmill. Do not wear loose clothes that could become caught in the treadmill. Athletic support clothes are recommended for both men and women. *Always wear athletic shoes. Never use the treadmill with bare feet, wearing only stockings, or in sandals.*
10. When connecting the power cord (See page 8), plug the power cord into a surge suppressor (not included) and plug the surge suppressor into a grounded circuit capable of carrying 15 or more amps. No other appliance should be on the same circuit. Do not use an extension cord.
11. Use only a single-outlet surge suppressor that meets all of the specifications described on page 8. To purchase a surge suppressor, see your local Sears or call 1-800-366-7278 and order part number 146148.
12. Failure to use a properly functioning surge suppressor could result in damage to the control system of the treadmill. If the control system is damaged, the walking belt may change speed or stop unexpectedly, which may result in a fall and serious injury.
13. Keep the power cord and the surge suppressor away from heated surfaces.
14. Never move the walking belt while the power is turned off. Do not operate the treadmill if the power cord or plug is damaged, or if the treadmill is not working properly. (See BEFORE YOU BEGIN on page 4 if the treadmill is not working properly.)
15. Never start the treadmill while you are standing on the walking belt. Always hold the handrails or upper body arms while using the treadmill.

16. The treadmill is capable of high speeds. Adjust the speed in small increments to avoid sudden jumps in speed.
17. Never leave the treadmill unattended while it is running. Always remove the key, unplug the power cord and move the on/off circuit breaker to the off position when the treadmill is not in use. (See the drawing on page 4 for the location of the on/off circuit breaker.)
18. Do not attempt to raise, lower, or move the treadmill until it is properly assembled. (See ASSEMBLY on page 5, and HOW TO FOLD AND MOVE THE TREADMILL on page 18.) You must be able to safely lift 45 pounds (20 kg) to raise, lower, or move the treadmill.
19. When folding or moving the treadmill, make sure that the storage latch is fully closed.

20. Inspect and properly tighten all parts of the treadmill regularly.
21. Never insert any object into any opening.
22. **DANGER:** Always unplug the power cord immediately after use, before cleaning the treadmill, and before performing the maintenance and adjustment procedures described in this manual. Never remove the motor hood unless instructed to do so by an authorized service representative. Servicing other than the procedures in this manual should be performed by an authorized service representative only.
23. This treadmill is intended for in-home use only. Do not use this treadmill in a commercial, rental, or institutional setting.

**WARNING:** Before beginning this or any exercise program, consult your physician. This is especially important for persons over the age of 35 or persons with pre-existing health problems. Read all instructions before using. Sears assumes no responsibility for personal injury or property damage sustained by or through the use of this product.

## SAVE THESE INSTRUCTIONS

The decals shown have been placed on your treadmill. If a decal is missing, or if it is not legible, please call toll-free 1-800-999-3756 to order a free replacement decal (see the front cover of this manual). Apply the decal in the location shown. Note: The decals are not shown at actual size.

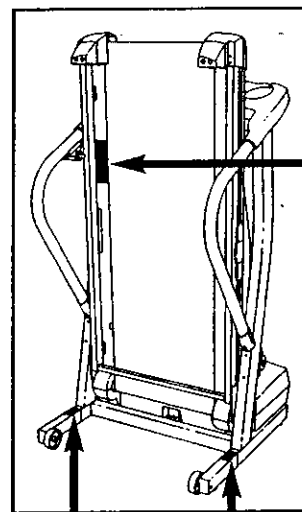
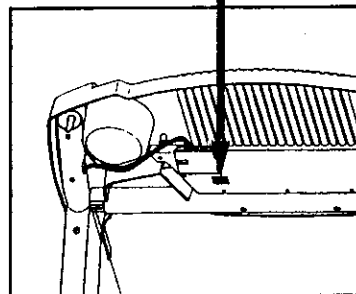
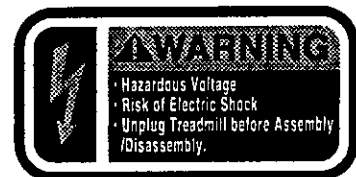

**WARNING:**

Protect yourself and others from risk of serious injury. Read the user's manual and:

- Stand only on the side rails when starting or stopping treadmill.
- Change speed in small increments.
- Hold handrails to prevent falling, and always wear the safety clip while operating treadmill.
- Stop if you feel faint, dizzy, or short of breath.
- Fully engage storage latch before treadmill is moved or stored.
- Reduce incline to its lowest level before folding treadmill into storage position.

---

- Never allow children on or around treadmill.
- Remove key when not in use.

---

- Keep clothing, fingers, and hair away from moving belt.
- Never try to adjust or fix the belt while it is moving.
- Always wear athletic shoes while operating treadmill.

# BEFORE YOU BEGIN

Thank you for selecting the revolutionary PROFORM® CROSSWALK 380x treadmill. The CROSSWALK 380x treadmill combines advanced technology with innovative design to help you get the most from your exercise program in the convenience and privacy of your home. And when you're not exercising, the unique CROSSWALK 380x treadmill can be folded up, requiring less than half the floor space of other treadmills.

**For your benefit, read this manual carefully before using the treadmill.** If you have questions after read-

ing this manual, call 1-800-4-MY-HOME® (1-800-469-4663). To help us assist you, please note the product model number and serial number before calling. The model number of the treadmill is 831.293040. The serial number can be found on a decal attached to the treadmill (see the front cover of this manual for the location).

Before reading further, please review the drawing below and familiarize yourself with the labeled parts.

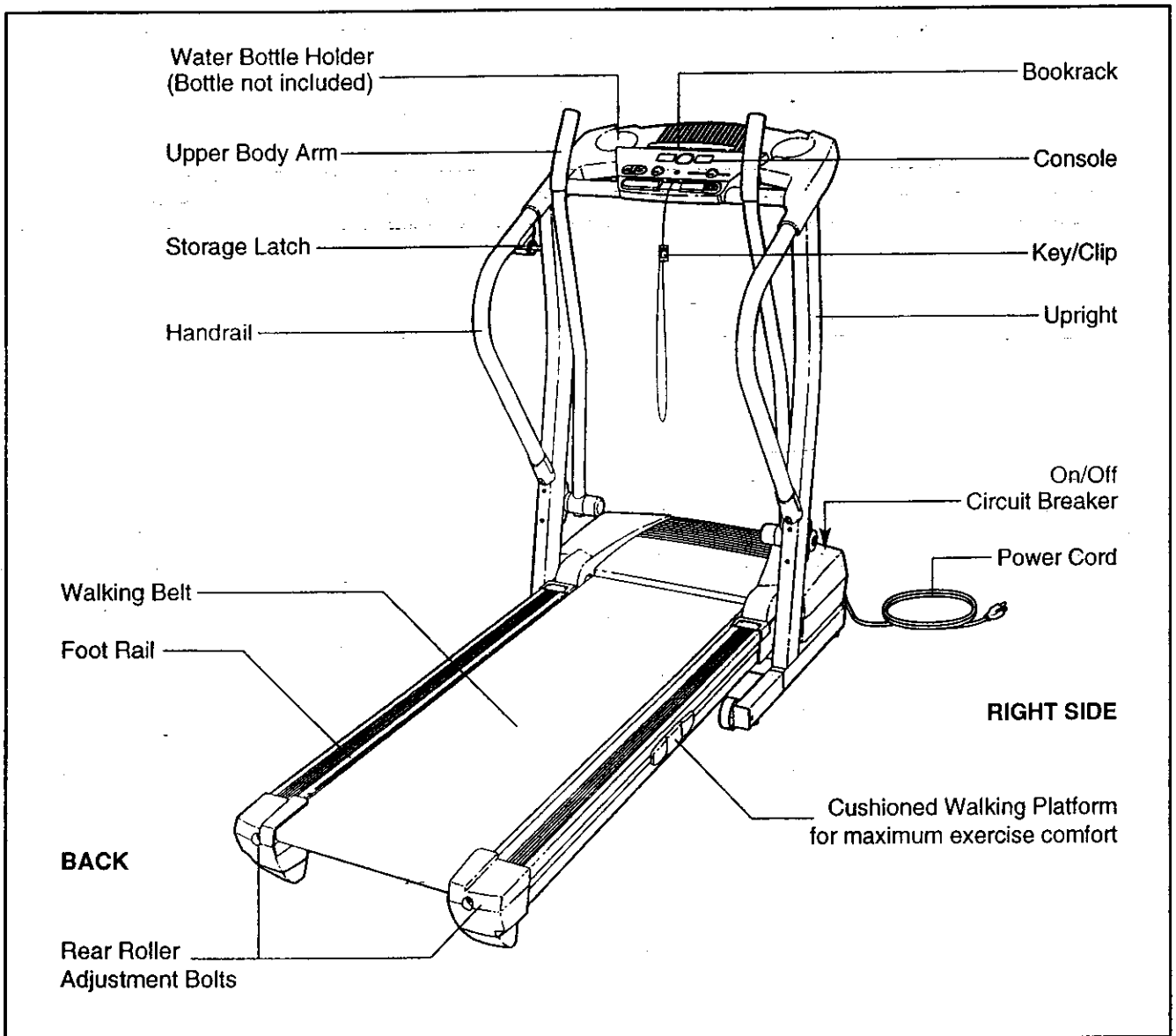

# ASSEMBLY

**Assembly requires two persons.** Set the treadmill in a cleared area and remove all packing materials. Do not dispose of the packing materials until assembly is completed. Note: The underside of the treadmill walking belt is coated with high-performance lubricant. During shipping, a small amount of lubricant may be transferred to the top of the walking belt or the shipping carton. This is a normal condition and does not affect treadmill performance. If there is lubricant on top of the walking belt, simply wipe off the lubricant with a soft cloth and a mild, non-abrasive cleaner.

Assembly requires the included allen wrenches  and your own phillips screwdriver , wire cutters , and needlenose pliers .

To identify small parts, use the **PART IDENTIFICATION CHART** attached in the center of this manual. Note: If a part is not in the parts bag, first check to see if it has been pre-assembled. If a part is missing, call toll-free 1-800-999-3756.

## 1. Make sure that the power cord is unplugged.



With the help of a second person, carefully raise the Uprights (69) until the treadmill is in the position shown. Insert one of the Extension Legs (63) into the treadmill as shown. (Note: It may be helpful to tip the Uprights as you insert the Extension Leg.) Make sure that the Warning Decal (62) is in the indicated location on the Extension Leg.

Insert the other Extension Leg (not shown) in the same way.

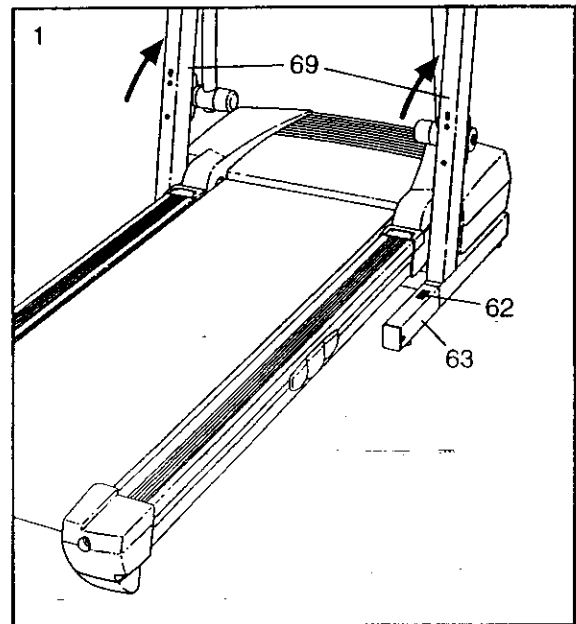

## 2. With the help of a second person, carefully lower the treadmill frame and then tip the Uprights (69) down as shown. (Note: It may be helpful to place your foot on one of the Extension Legs [63] as you tip the Uprights.) **Make sure that the Extension Legs remain in the Uprights.**

Attach each Extension Leg (63) with two 3/4" Tek Screws (58).

Attach four Base Pads (57) with four 3/4" Tek Screws (58) as shown. Note: One replacement Base Pad may be included. If a Base Pad becomes worn and needs to be replaced, use the replacement Base Pad.

With the help of a second person, raise the Uprights (69) to the vertical Position.

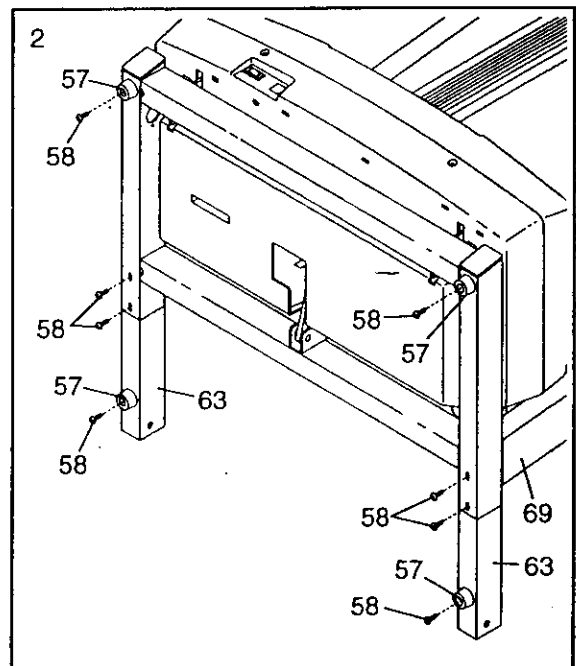

- Identify the Right Handrail (72), which has a large hole in the left side. Feed the Wire Harness (42) up into the bracket on the Right Handrail and out of the large hole in the left side. (Note: It may be helpful to use needlenose pliers to pull the Wire Harness out of the large hole.) Press a Handrail Cap (76) onto the lower end of the Right Handrail as shown. Remove any plastic ties from the bracket.

Insert the bracket on the Right Handrail (72) into the top of the right Upright (69) so the Handrail Cap (76) is resting against the Upright. Attach the Right Handrail and the Handrail Cap with **three 3/4" Bolts (37) and two Washers (38)** as shown. **Do not tighten the Bolts yet.**

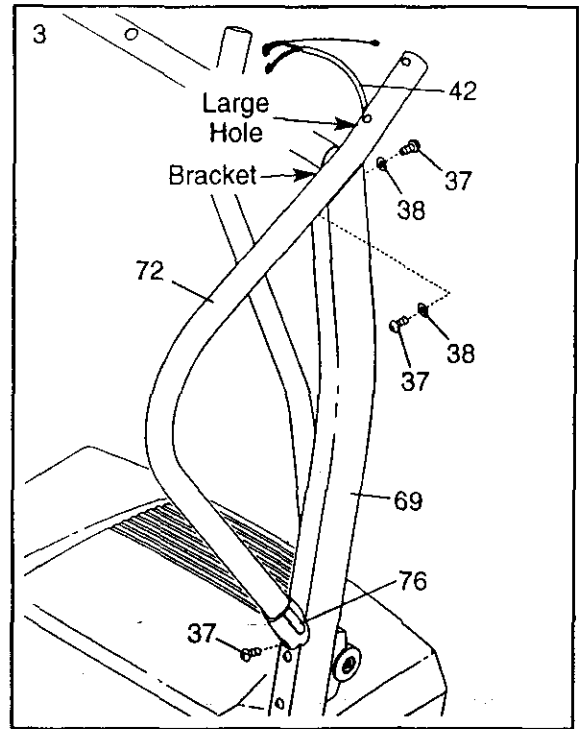

- Attach the Storage Latch (36) and the Latch Spacer (29) to the Left Handrail (71) with two 1" Latch Screws (123).

Remove the Latch Knob (30) from the Latch Pin (35). Make sure that the Latch Pin Collar (33) and the Spring (32) are on the Latch Pin as shown. Insert the Latch Pin into the Storage Latch (36) and tighten the Latch Knob back onto the Latch Pin.

Attach the Left Handrail (71) as described in step 3.  
Note: There is not a wire harness on the left side.

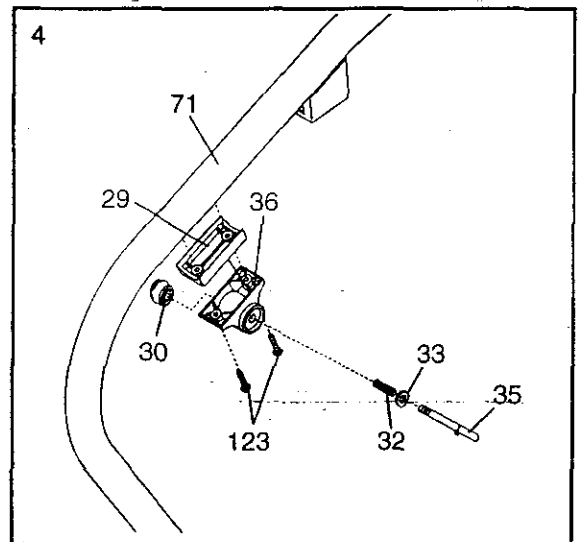

- Attach the end of the ground wire to the small hole in the side of the Right Handrail (72) with a Silver Ground Screw (75).

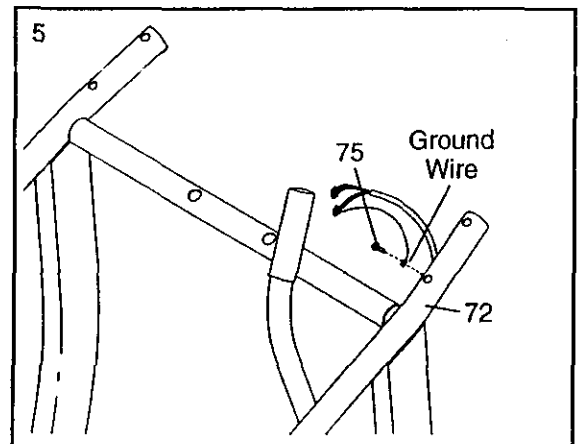

- Place the Console Base (47) on the Right Handrail (72) and the Left Handrail (not shown). Attach the Console Base with four 3/4" Screws (2) (only two Screws are shown). **Do not overtighten the Screws.**

Insert the Wire Harness (42) through the two indicated plastic ties on the Console Base (47). Next, **touch the Right Handrail (72) to discharge any static.** Refer to the inset drawing. Find the 3-wire connector on the end of the Wire Harness (42). Insert the connector into the red socket beneath the console. **The connector should slide easily into the socket and "snap" into place.** If the connector does not slide easily and snap into place, turn the connector and then insert it. Insert the 5-wire connector into the black socket beneath the console in the same way.

Make sure that the connectors and wires appear as shown at the right. **IF THE CONNECTORS ARE NOT INSERTED PROPERLY, THE CONSOLE MAY BE DAMAGED WHEN THE POWER IS TURNED ON.**

If you plan to use iFIT.com CD's or videocassettes, or programs from our Web site (see page 13), plug the Audio Cable (120) into the jack on the back of the Console (43).

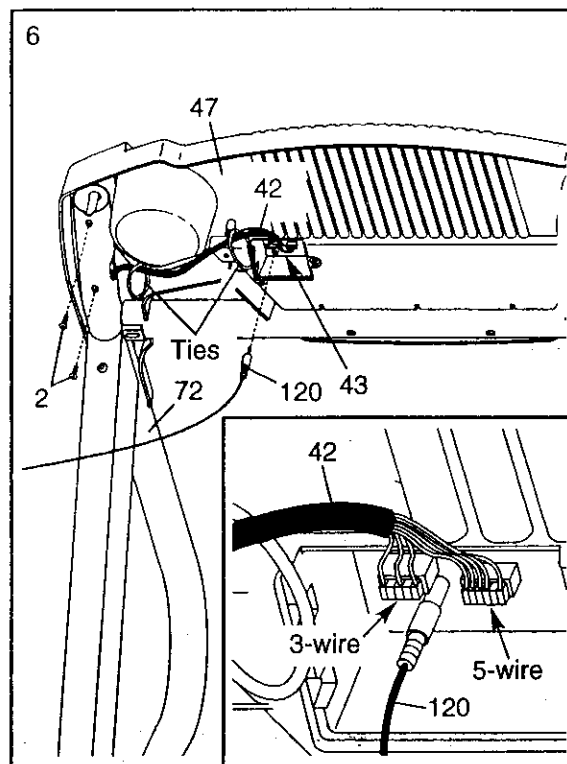

- Insert the excess Wire Harness (42) into the large hole in the side of the Right Handrail (72). **Securely tighten the plastic ties on the bottom of the Console Base (47) to prevent the Wire Harness from slipping.** Then, cut off the ends of the plastic ties.

Route the Wire Harness (42) through the indicated opening in the Console Base (47). If you connected the Audio Cable (120) in step 5, route it through the slot in the Wire Cover (44). Attach the Wire Cover to the Console Base with a 1/2" Silver Screw (48).

Tighten two 3/4" Screws (2) into the Console Base (47).

Refer to step 3 and 4. Firmly tighten the three 3/4" Bolts (37) in each Handrail (72, 71).

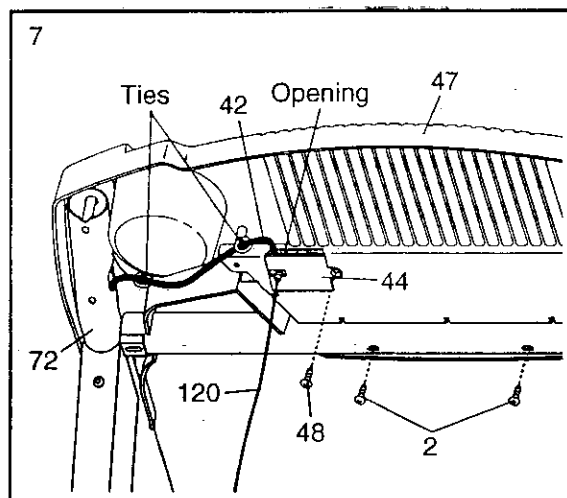

- Attach a Wheel (66) to the inner side of each Extension Leg (63) with a Wheel Bolt (64) and a Wheel Nut (13) as shown. **Do not overtighten the Bolts.** The Wheels should be able to spin freely.

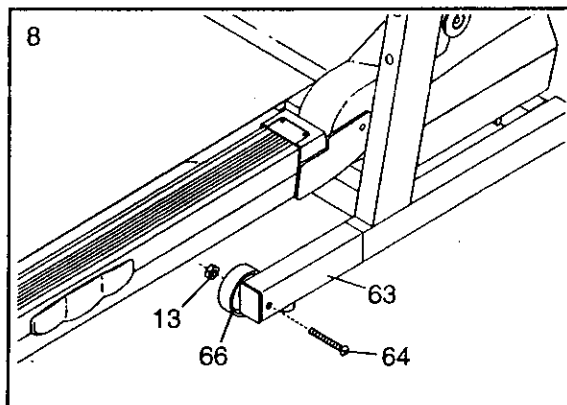

- Make sure that all parts are properly tightened before you use the treadmill.** Note: Extra hardware may be included. Keep the included allen wrenches in a secure place. The large allen wrench is used to adjust the walking belt (see page 21). To protect the floor or carpet, place a mat under the treadmill.



# OPERATION AND ADJUSTMENT

## THE PERFORMANT LUBE™ WALKING BELT

Your treadmill features a walking belt coated with PERFORMANT LUBE™, a high-performance lubricant. **IMPORTANT:** Never apply silicone spray or other substances to the walking belt or the walking platform. Such substances will deteriorate the walking belt and cause excessive wear.

## HOW TO PLUG IN THE POWER CORD

**⚠ DANGER:** Improper connection of the equipment-grounding conductor can result in an increased risk of electric shock. Check with a qualified electrician or serviceman if you are in doubt as to whether the product is properly grounded. Do not modify the plug provided with the product—if it will not fit the outlet, have a proper outlet installed by a qualified electrician.

Your treadmill, like any other type of sophisticated electronic equipment, can be seriously damaged by sudden voltage changes in your home's power. Voltage surges, spikes, and noise interference can result from weather conditions or from other appliances being turned on or off. **To decrease the possibility of your treadmill being damaged, always use a surge suppressor with your treadmill (see drawing 1 at the right).** To purchase a surge suppressor, see your local Sears or call 1-800-366-7278 and order part number 146148.

Use only a single-outlet surge suppressor that is UL 1449 listed as a transient voltage surge suppressor (TVSS). The surge suppressor must have a UL suppressed voltage rating of 400 volts or less and a minimum surge dissipation of 450 joules. The surge suppressor must be electrically rated for 120 volts AC and 15 amps. There must be a monitoring light on the surge suppressor to indicate whether it is functioning properly. Failure to use a properly functioning surge suppressor could result in damage to the control system of the treadmill. If the control system is damaged, the walking belt may change speed or stop unexpectedly, which may result in a fall and serious injury.

**This product must be grounded.** If it should malfunction or break down, grounding provides a path of least resistance for electric current to reduce the risk of electric shock. This product is equipped with a cord having

an equipment-grounding conductor and a grounding plug. **Plug the power cord into a surge suppressor, and plug the surge suppressor into an appropriate outlet that is properly installed and grounded in accordance with all local codes and ordinances. Important: The treadmill is not compatible with GFCI-equipped outlets.**

This product is for use on a nominal 120-volt circuit, and has a grounding plug that looks like the plug illustrated in drawing 1 below. A temporary adapter that looks like the adapter illustrated in drawing 2 may be used to connect the surge suppressor to a 2-pole receptacle as shown in drawing 2 if a properly grounded outlet is not available.

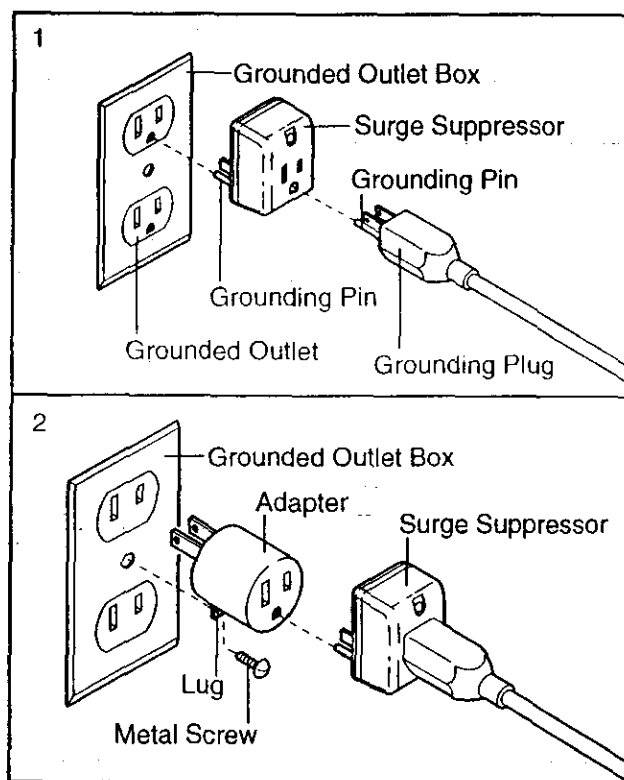

The temporary adapter should be used only until a properly grounded outlet (drawing 1) can be installed by a qualified electrician.

The green-colored rigid ear, lug, or the like extending from the adapter must be connected to a permanent ground such as a properly grounded outlet box cover. Whenever the adapter is used it must be held in place by a metal screw. **Some 2-pole receptacle outlet box covers are not grounded. Contact a qualified electrician to determine if the outlet box cover is grounded before using an adapter.**



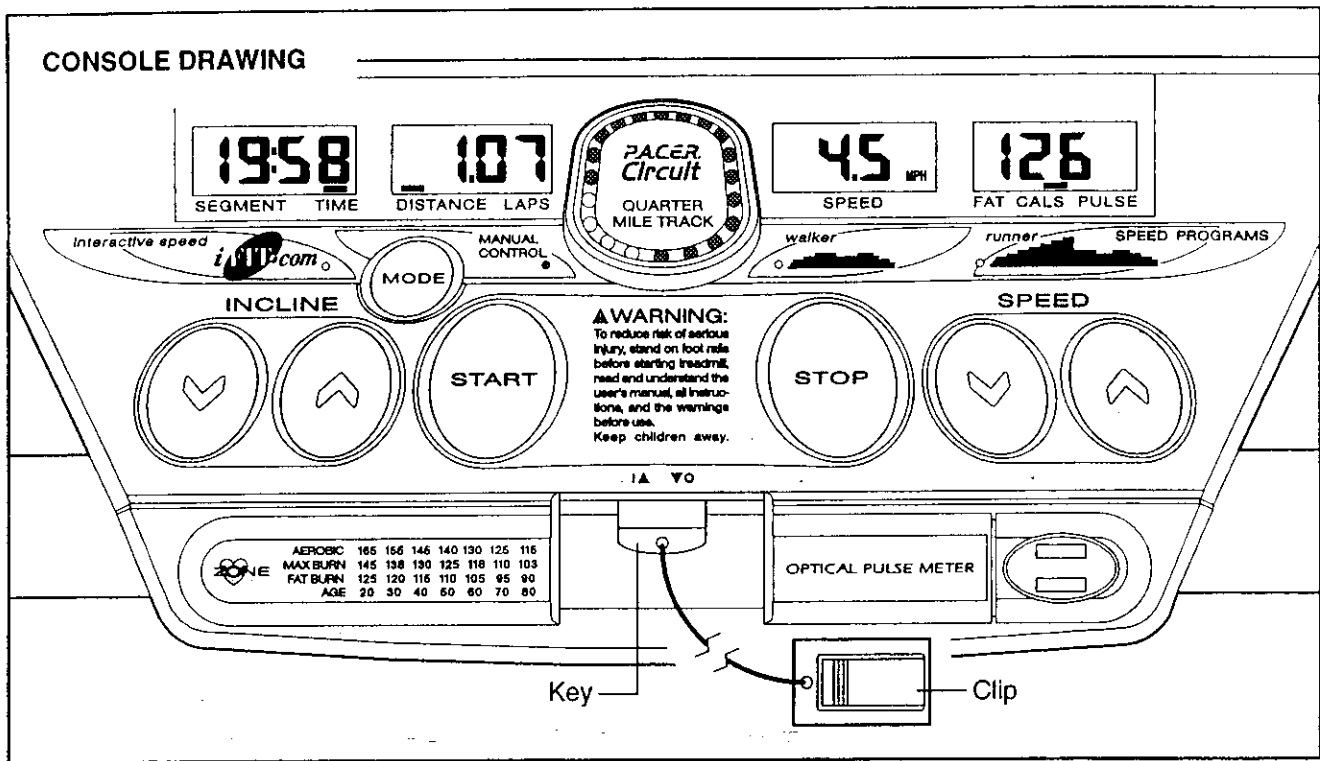

**CAUTION:** Before operating the console, read the following precautions.

- Do not stand on the walking belt when turning on the power.
- Always wear the clip (see the drawing above) while operating the treadmill.
- Adjust the speed in small increments in order to avoid sudden jumps in speed.
- To reduce the possibility of electric shock, keep the console dry. Avoid spilling liquids on the console and place only a sealed water bottle in the water bottle holder.

**FEATURES OF THE CONSOLE**

The treadmill console offers a selection of features that are designed to help you get the most from your workouts. When the manual mode of the console is selected, the speed and incline of the treadmill can be changed with a touch of a button. As you exercise, the track and the four displays will provide continuous exercise feedback. You can even measure your heart rate using the built-in pulse sensor.

Two workout programs are also offered. Each program automatically controls the speed of the treadmill as it guides you through an effective workout.

The console also features advanced iFIT.com interactive technology. Having iFIT.com technology is like having a personal trainer in your home. Using the included audio cable, you can connect the treadmill to your home stereo, portable stereo, or computer and play special iFIT.com CD programs (CD's are sold separately). iFIT.com CD programs automatically control the speed of the treadmill as a personal trainer guides you through every step of your workout. High-energy music provides added motivation. Each CD features two different programs designed by certified personal trainers.

In addition, you can connect the treadmill to your VCR and TV and play iFIT.com video programs (videocassettes are available separately). Video programs offer the same benefits as iFIT.com CD programs, and allow you to enjoy breathtaking scenery while you exercise.

With the treadmill connected to your computer, you can also go to our Web site at [www.iFIT.com](http://www.iFIT.com) and access programs directly from the internet. Additional options are soon to be available. See [www.iFIT.com](http://www.iFIT.com) for details.

To purchase iFIT.com CD's or videocassettes, call toll-free 1-800-735-0768.

To use the manual mode of the console, follow the steps beginning on page 10. To use a workout program, see page 12. To use an iFIT.com CD or video program, see page 15. To use an iFIT.com program directly from our Web site, see page 17.

## HOW TO TURN ON THE POWER

Note: If there is a thin sheet of clear plastic on the console, remove the plastic.

- 1 Plug in the power cord (see page 8).

- 2 Locate the on/off circuit breaker on the front of the treadmill near the power cord. Make sure that the breaker is in the reset position.

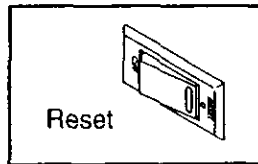

- 3 Stand on the foot rails of the treadmill. Find the clip attached to the key, and slide the clip onto the waistband of your clothes. Next, insert the key into the console. After a moment, the displays and various indicators on the console will light. Test the clip by carefully taking a few steps backward until the key is pulled from the console. If the key is not pulled from the console, adjust the position of the clip as needed.

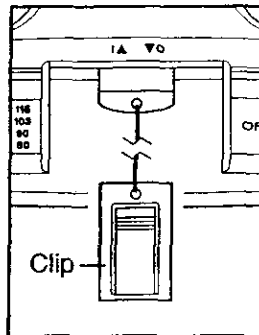

## HOW TO USE THE MANUAL MODE

- 1 Insert the key fully into the console.  
See HOW TO TURN ON THE POWER above.

- 2 Select the manual mode.

When the key is inserted, the manual mode will automatically be selected and the Manual Control indicator will light. If a program has been selected, press the Mode button repeatedly to select the manual mode.

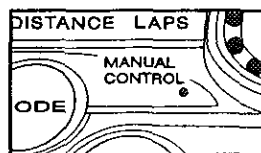

- 3 Press the Start button or the Speed  $\Delta$  button to start the walking belt.

A moment after the button is pressed, the walking belt will begin to move. Hold the handrails and begin walking.

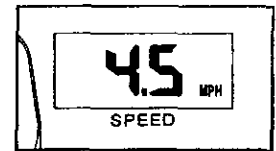

As you exercise, change the speed of the walking belt as desired by pressing the Speed buttons. Each time a button is pressed, the speed will change by 0.1 mph. If a button is held down, the speed will change in increments of 0.5 mph.

To stop the walking belt, press the Stop button. The Time display will begin to flash. To restart the walking belt, press the Start button or the Speed  $\Delta$  button.

Note: During the first few minutes that the treadmill is used, observe the alignment of the walking belt, and align it if necessary (see page 21).

- 4 Change the incline of the treadmill as desired.

To change the incline of the treadmill, press either of the Incline buttons until the desired incline level is reached.

- 5 Follow your progress with the LED track and the four displays.

**The LED Track**—The LED track represents a distance of 1/4 mile (400 m). As you exercise, the indicators around the track will light, one at a time, until you have completed 1/4 mile. A new lap will then begin.

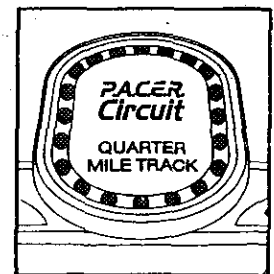

**Time display**—When the manual mode or the iFIT.com mode is selected, this display will show the elapsed time. When a workout program is selected, the display will show the time remaining in the program and the time remaining in the current segment of the program. The display will alternate between one number and the other every few seconds, as shown by the indicators in the display.

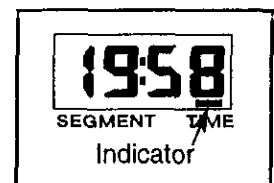

### Distance/Laps

**display**—This display shows the distance that you have walked or run and the number of 1/4-mile laps you have completed. The display will alternate between one number and the other every few seconds, as shown by the indicators in the display.

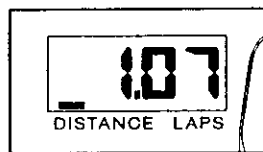

**Speed display**—This display shows the speed of the walking belt.

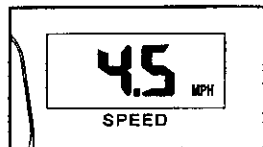

Note: The console can display speed and distance in either miles or kilometers. The letters "MPH" or "KPH" will appear in the Speed display to show which unit of measurement is selected. To change the unit of measurement, hold down the Stop button, insert the key into the console, and continue to hold the Stop button for a moment. An "E" for English miles or an "M" for metric kilometers will appear in the Fat Calories/Calories/Pulse display. Press the Speed  $\Delta$  button to change the unit of measurement. When the desired unit of measurement is selected, remove the key and then reinsert it.

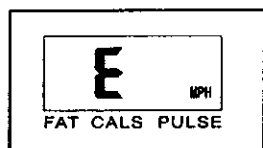

**Fat Calories/Calories/Pulse display**—This display shows the approximate numbers of *fat calories* and *calories* you have burned (see FAT BURNING on page 22). The display will alternate between one number and the other every few seconds, as shown by the indicators in the display. The display will also show your heart rate when you use the pulse sensor (see step 6).

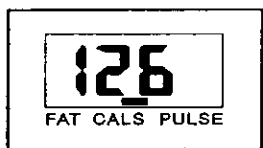

### 6 Measure your heart rate, if desired.

To measure your heart rate, stand on the foot rails and place your thumb on the pulse sensor.

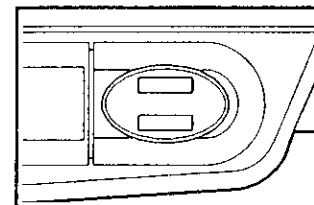

**Do not press too hard, or the circulation in your thumb will be restricted and your pulse will not be detected.** After a few seconds, the heart-shaped indicator in the Fat Calories/Calories/Pulse display will begin to flash, one or two dashes (--) will appear, and then your heart rate will be shown. Hold your thumb on the pulse sensor for about 15 seconds for the most accurate reading.

If the displayed heart rate appears to be too high or too low, or if your heart rate is not displayed, lift your thumb off the pulse sensor for a few seconds. Then, place your thumb on the pulse sensor as described above. Remember to stand still while measuring your heart rate.

### 7 When you are finished exercising, remove the key.

Step onto the foot rails, press the Stop button, and adjust the incline of the treadmill to the lowest level. **The incline must be at the lowest level when the treadmill is raised to the storage position or the treadmill will be damaged.** Next, remove the key from the console and put the key in a secure place.

When you are finished using the treadmill, move the on/off circuit breaker near the power cord to the off position.

## HOW TO USE A WORKOUT PROGRAM

### 1 Insert the key into the console.

See HOW TO TURN ON THE POWER on 10.

### 2 Select one of the workout programs.

When the key is inserted, the manual mode will be selected. To select a workout program, press the Mode button repeatedly until the Walker indicator or the Runner indicator lights.

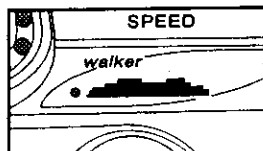

When a workout program is selected, the maximum speed setting for the program will flash in the Speed display for a few seconds. The Time display will show how long the program will last. Note: The profiles beside the Walker and Runner indicators show how the speed of the treadmill will change during the workout programs.

### 3 Press the Start button or the Speed $\Delta$ button to start the program.

A moment after the button is pressed, the treadmill will automatically adjust to the first speed setting for the program. Hold the handrails and begin walking.

Each program is divided into several time periods of different lengths. One speed setting is programmed for each period. (The same speed setting may be programmed for consecutive periods.) When only three seconds remain in the first period of the program, a series of tones will sound. If the speed of the treadmill is about to change, the Speed display will flash to alert you, and then the treadmill will automatically adjust to the speed setting for the second period.

The program will continue in this way until no time remains in the Time display. The walking belt will then slow to a stop.

During the program, the incline of the treadmill can be adjusted with the Incline buttons. If the speed setting for the current period is too high or too low, you can manually override the setting by pressing the Speed buttons on the console. However, **when the next period begins, the treadmill will adjust to the next speed setting for the program.**

To stop the program, press the Stop button. The Time display will begin to flash. To restart the program, press the Start button or the Speed  $\Delta$  button. To end the program, press the Stop button, remove the key, and then reinsert the key.

### 4 Follow your progress with the LED track and the four displays.

Refer to step 5 on page 10.

### 5 Measure your heart rate if desired.

See step 6 on page 11.

### 6 When the program ends, remove the key from the console.

When the program ends, **make sure that the treadmill is at the lowest incline level.** Next, remove the key from the console and put it in a secure place.

When you are finished using the treadmill, move the on/off circuit breaker near the power cord to the off position.

## HOW TO CONNECT THE TREADMILL TO YOUR CD PLAYER, VCR, OR COMPUTER

To use iFIT.com CD's, the treadmill must be connected to your portable CD player, portable stereo, home stereo, or computer with CD player. See pages 13 and 14 for connecting instructions. To use iFIT.com videocassettes, the treadmill must be connected to your VCR. See page 15 for connecting instructions. To use iFIT.com programs directly from our internet site, the treadmill must be connected to your home computer. See page 14 for connecting instructions.

## HOW TO CONNECT YOUR PORTABLE CD PLAYER

Note: If your CD player has separate LINE OUT and PHONES jacks, see instruction A below. If your CD player has only one jack, see instruction B.

- A. Plug one end of the audio cable into the jack beneath the console. Plug the other end of the cable into the LINE OUT jack on your CD player. Plug your headphones into the PHONES jack.

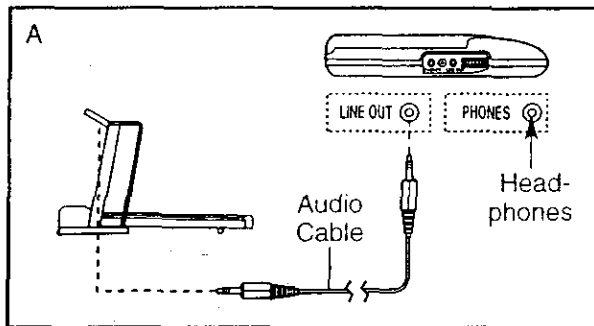

- B. Plug one end of the audio cable into the jack beneath the console. Plug the other end of the cable into a 3.5mm Y-adaptor (available at electronics stores). Plug the Y-adaptor into the PHONES jack on your CD player. Plug your headphones into the other side of the Y-adaptor.

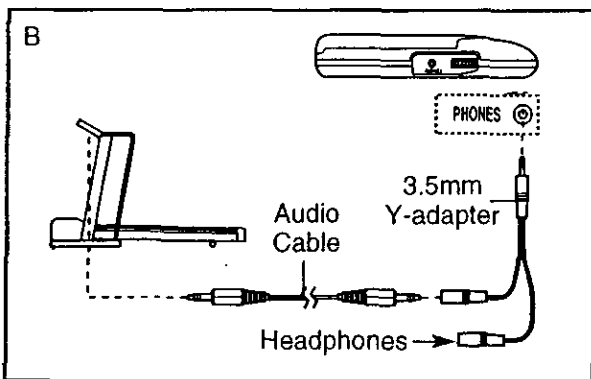

## HOW TO CONNECT YOUR PORTABLE STEREO

Note: If your stereo has an RCA-type AUDIO OUT jack, see instruction A below. If your stereo has a 3.5mm LINE OUT jack, see instruction B. If your stereo has only a PHONES jack, see instruction C.

- A. Plug one end of the audio cable into the jack beneath the console. Plug the other end of the cable into the included adaptor. Plug the adaptor into an AUDIO OUT jack on your stereo.

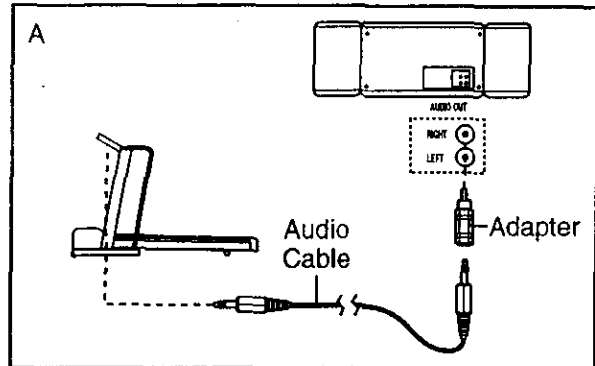

- B. Plug one end of the audio cable into the jack beneath the console. Plug the other end of the cable into the LINE OUT jack on your stereo.

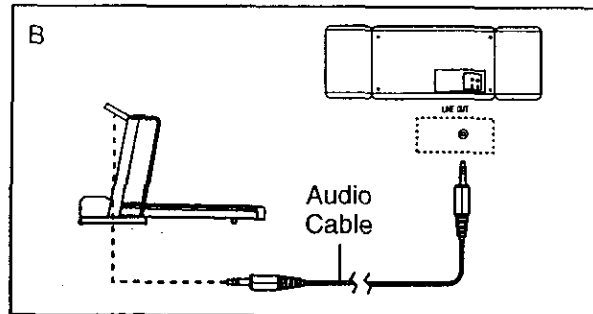

- C. Plug one end of the audio cable into the jack beneath the console. Plug the other end of the cable into a 3.5mm Y-adaptor (available at electronics stores). Plug the Y-adaptor into the PHONES jack on your stereo. Plug your headphones into the other side of the Y-adaptor.

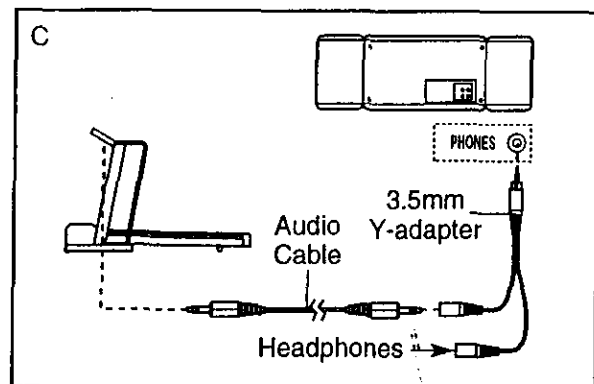

## HOW TO CONNECT YOUR HOME STEREO

**Note:** If your stereo has an unused **LINE OUT** jack, see instruction A below. If the **LINE OUT** jack is being used, see instruction B.

- A. Plug one end of the audio cable into the jack beneath the console. Plug the other end of the cable into the included adapter. Plug the adapter into the **LINE OUT** jack on your stereo.

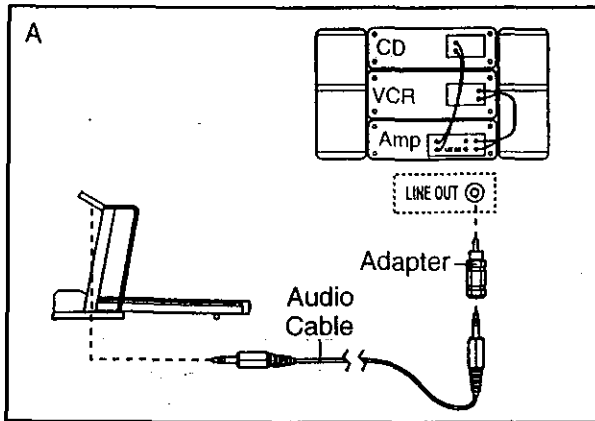

- B. Plug one end of the audio cable into the jack beneath the console. Plug the other end of the cable into the included adapter. Plug the adapter into an **RCA Y-adapter** (available at electronics stores). Next, remove the wire that is currently plugged into the **LINE OUT** jack on your stereo and plug the wire into the unused side of the **Y-adapter**. Plug the **Y-adapter** into the **LINE OUT** jack on your stereo.

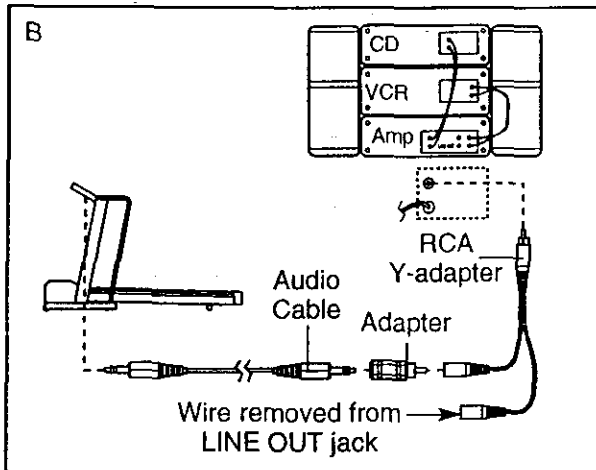

## HOW TO CONNECT YOUR COMPUTER

**Note:** If your computer has a **3.5mm LINE OUT** jack, see instruction A. If your computer has only a **PHONES** jack, see instruction B.

- A. Plug one end of the audio cable into the jack beneath the console. Plug the other end of the cable into the **LINE OUT** jack on your computer.

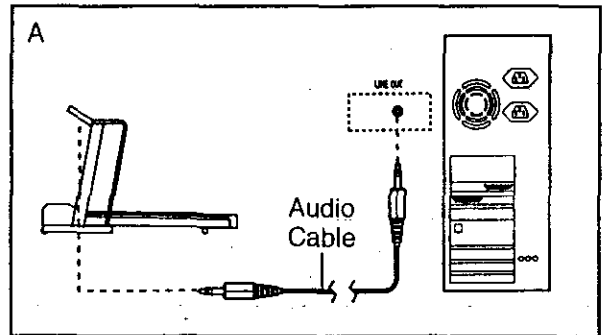

- B. Plug one end of the audio cable into the jack beneath the console. Plug the other end of the cable into a **3.5mm Y-adapter** (available at electronics stores). Plug the **Y-adapter** into the **PHONES** jack on your computer. Plug your **headphones or speakers** into the other side of the **Y-adapter**.

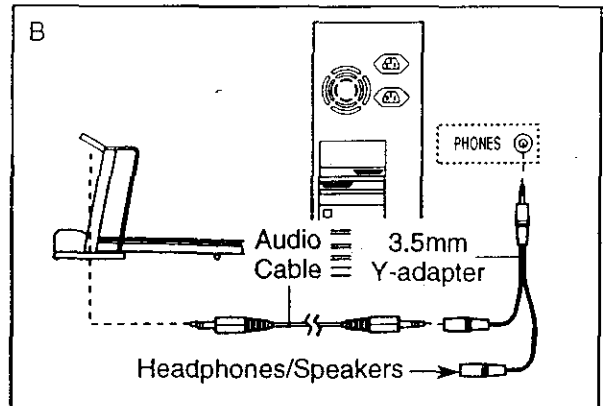

## HOW TO CONNECT YOUR VCR

**Note:** If your VCR has an unused AUDIO OUT jack, see instruction A below. If the AUDIO OUT jack is being used, see instruction B. If you have a TV with a built-in VCR, see instruction B. If your VCR is connected to your home stereo, see HOW TO CONNECT YOUR HOME STEREO on page 14.

- A. Plug one end of the audio cable into the jack beneath the console. Plug the other end of the cable into the included adapter. Plug the adapter into the AUDIO OUT jack on your VCR.

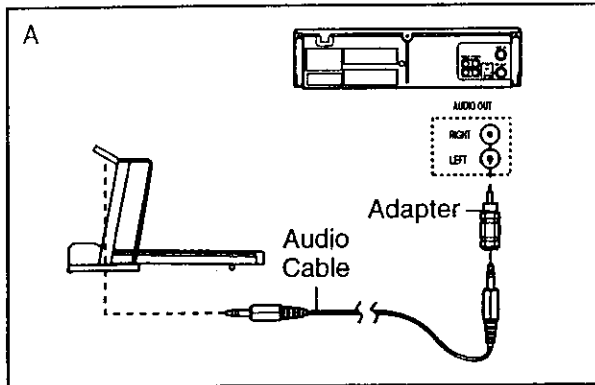

- B. Plug one end of the audio cable into the jack beneath the console. Plug the other end of the cable into the included adapter. Plug the adapter into an RCA Y-adapter (available at electronics stores). Next, remove the wire that is currently plugged into the AUDIO OUT jack on your VCR and plug the wire into the unused side of the Y-adapter. Plug the Y-adapter into the AUDIO OUT jack on your VCR.

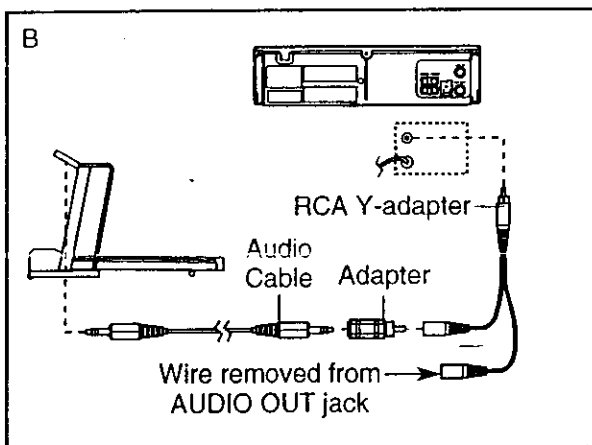

## HOW TO USE iFIT.COM CD AND VIDEO PROGRAMS

To use iFIT.com CD's or videocassettes, the treadmill must be connected to your portable CD player, portable stereo, home stereo, computer with CD player, or VCR. See HOW TO CONNECT THE TREADMILL TO YOUR CD PLAYER, VCR, OR COMPUTER on page 13. **Note:** To purchase iFIT.com CD's or iFIT.com videocassettes, call toll-free 1-800-735-0768.

Follow the steps below to use an iFIT.com CD or video program.

- 1** Insert the key fully into the console.

See HOW TO TURN ON THE POWER on page 10.

- 2** Select the iFIT.com mode.

When the key is inserted, the manual mode will automatically be selected. To use an iFIT.com CD or video program, press the Mode button repeatedly until the iFIT.com indicator lights.

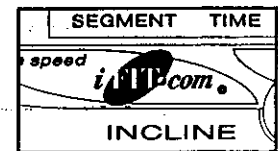

- 3** Insert the iFIT.com CD or videocassette.

If you are using an iFIT.com CD, insert the CD into your CD player. If you are using an iFIT.com videocassette, insert the videocassette into your VCR.

- 4** Press the PLAY button on your CD player or VCR.

A moment after the button is pressed, your personal trainer will begin guiding you through your workout. Simply follow your personal trainer's instructions. **Note:** If the Time display is flashing, press the Start button or the Speed  $\Delta$  button on the console. The treadmill will not respond to a CD or video program when the Time display is flashing.

During the CD or video program, an electronic "chirping" sound will alert you when the speed of the treadmill is about to change. **CAUTION: Always listen for the "chirp" and be prepared for speed changes. In some instances, the speed may change before the personal trainer describes the change.**



If the speed setting is too high or too low, you can manually override the setting at any time by pressing the Speed buttons on the console. However, **when the next “chirp” is heard, the speed will change to the next setting for the CD or video program.**

To stop the walking belt at any time, press the Stop button on the console. The Time display will begin to flash. To restart the program, press the Start button or the Speed  $\Delta$  button. After a moment, the walking belt will begin to move at 1.0 mph. **When the next “chirp” is heard, the speed will change to the next setting for the CD or video program.**

When the CD or video program is completed, the walking belt will stop and the Time display will begin to flash. Note: To use another CD or video program, press the Stop button or remove the key and go to step 1 on page 15.

**Note: If the speed of the treadmill does not change when a “chirp” is heard:**

- **Make sure that the iFIT.com indicator is lit and that the Time display is not flashing. If the Time display is flashing, press the Start-button or the Speed  $\Delta$  button on the console.**

- **Adjust the volume of your CD player or VCR. If the volume is too high or too low, the console may not detect the program signals.**
- **Make sure that the audio cable is properly connected, that it is fully plugged in, and that it is not wrapped around a power cord.**
- **If you are using your portable CD player and the CD skips, set the CD player on the floor or another flat surface instead of on the console.**

**5 Follow your progress with the LED track and the four displays.**

See step 5 on page 10.

**6 Measure your heart rate if desired.**

See step 6 on page 11.

**7 When the iFIT.com CD or video program ends, remove the key.**

See step 6 on page 12.

**CAUTION:** Always remove iFIT.com CD's and videocassettes from your CD player or VCR when you are finished using them.

## HOW TO USE PROGRAMS DIRECTLY FROM OUR WEB SITE

Our Web site at [www.iFIT.com](http://www.iFIT.com) allows you to access basic programs, audio programs, and video programs directly from the internet. Additional options are soon to be available. See [www.iFIT.com](http://www.iFIT.com) for details.

To use programs from our Web site, the treadmill must be connected to your home computer. See HOW TO CONNECT YOUR COMPUTER on page 14. In addition, you must have an internet connection and an internet service provider. A list of specific system requirements will be found on our Web site.

Follow the steps below to use a program from our Web site.

### 1 Insert the key into the console.

See HOW TO TURN ON THE POWER on page 10.

### 2 Select the iFIT.com mode.

When the key is inserted, the manual mode will be selected and the manual indicator will light. To use a program from our Web site, press the Mode button repeatedly until the iFIT.com indicator lights.

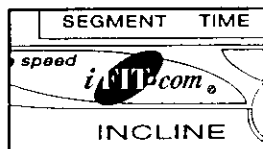

### 3 Go to your computer and start an internet connection.

### 4 Start your Web browser, if necessary, and go to our Web site at [www.iFIT.com](http://www.iFIT.com).

### 5 Follow the desired links on our Web site to select a program.

Read and follow the on-line instructions for using a program.

### 6 Follow the on-line instructions to start the program.

When you start the program, an on-screen countdown will begin.

### 7 Return to the treadmill and stand on the foot rails. Find the clip attached to the key, and slide the clip onto the waistband of your clothes.

When the on-screen countdown ends, the program will begin and the walking belt will begin to move. Hold the handrails, step onto the walking belt, and begin walking.

During the program, an electronic “chirping” sound will alert you when the speed of the treadmill is about to change. **CAUTION: Always listen for the “chirp” and be prepared for speed changes.**

If the speed setting is too high or too low, you can manually override the setting at any time by pressing the Speed buttons on the console. **However, when the next “chirp” is heard, the speed will change to the next setting for the program.**

To stop the walking belt at any time, press the Stop button on the console. The Time display will begin to flash. To restart the program, press the Start button or the Speed  $\Delta$  button. After a moment, the walking belt will begin to move at 1.0 mph. **When the next “chirp” is heard, the speed will change to the next setting for the program.**

When the program is completed, the walking belt will stop and the Time display will begin to flash. Note: To use another program, press the Stop button and go to step 5.

**Note: If the speed of the treadmill does not change when a “chirp” is heard, make sure the iFIT.com indicator is lit and the Time display is not flashing. In addition, make sure that the audio cable is properly connected, that it is fully plugged in, and that it is not wrapped around a power cord.**

### 8 Follow your progress with the LED track and the four displays.

See step 5 on page 10.

### 9 Measure your heart rate if desired.

See step 6 on page 11.

### 10 When the program ends, remove the key.

See step 6 on page 12.

## HOW TO USE THE UPPER BODY ARMS

As you walk on the treadmill, you can either hold the handrails or use the upper body arms. To exercise your arms, shoulders, and back for a total body workout, move the upper body arms forward and back as you walk on the treadmill.

To vary the intensity of your upper body exercise, the resistance of the upper body arms can be adjusted. To increase the resistance, turn the resistance knobs clockwise; to decrease the resistance, turn the knobs counterclockwise.

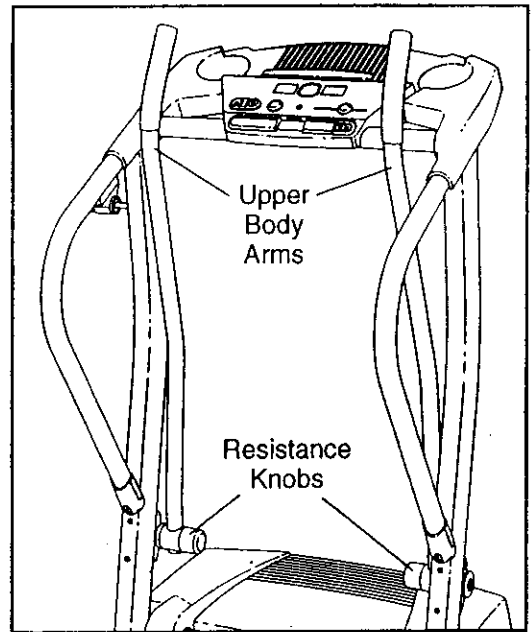

---

## HOW TO FOLD AND MOVE THE TREADMILL

### HOW TO FOLD THE TREADMILL FOR STORAGE

Before folding the treadmill, unplug the power cord. **CAUTION:** You must be able to safely lift 45 pounds (20 kg) in order to raise, lower, or move the treadmill.

1. Hold the treadmill with your hands in the locations shown at the right. **To decrease the possibility of injury, bend your legs and keep your back straight. As you raise the treadmill, make sure to lift with your legs rather than your back.** Raise the treadmill about halfway to the vertical position.

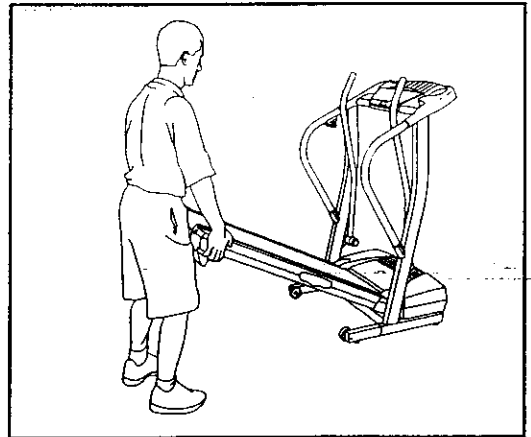

2. Move your right hand to the position shown and hold the treadmill firmly. Using your left hand, pull the latch knob to the left and hold it. Raise the treadmill until the frame is past the latch pin. Slowly release the latch knob. **Make sure that the frame is securely held by the latch pin.**

To protect the floor or carpet from damage, place a mat under the treadmill. Keep the treadmill out of direct sunlight. Do not leave the treadmill in the storage position in temperatures above 85° Fahrenheit.

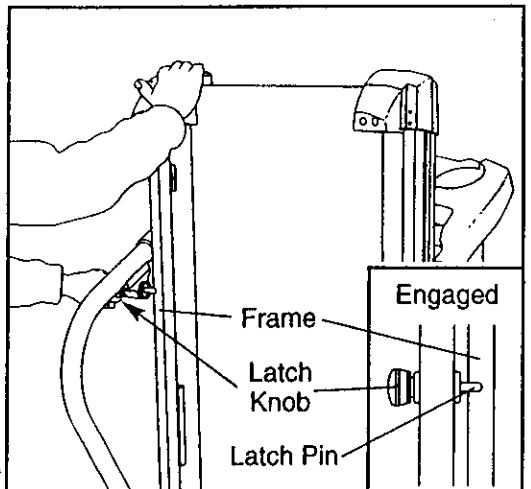

## HOW TO MOVE THE TREADMILL

Before moving the treadmill, convert the treadmill to the storage position as described above. **Make sure that the frame is securely held by the latch pin.**

1. Hold the upper ends of the handrails. Place one foot on the base as shown.
2. Tilt the treadmill back until it rolls freely on the front wheels. Carefully move the treadmill to the desired location. **To reduce the risk of injury, use extreme caution while moving the treadmill. Do not move the treadmill over an uneven surface.**
3. Place one foot on the base, and carefully lower the treadmill until it is resting in the storage position.

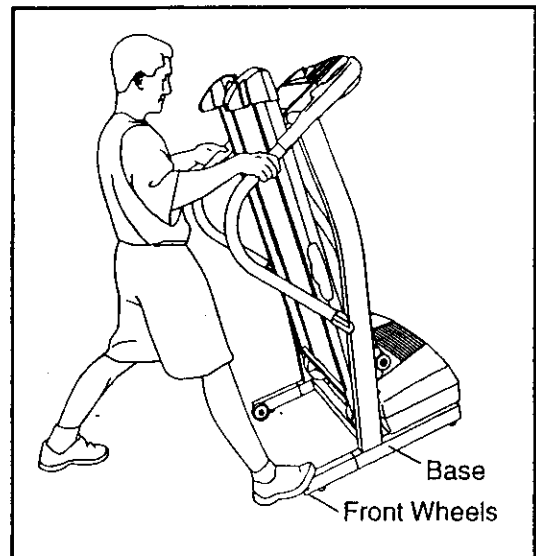

## HOW TO LOWER THE TREADMILL FOR USE

1. Hold the upper end of the treadmill with your right hand as shown. Using your left hand, pull the latch knob to the left and hold it. Pivot the treadmill down until the frame is past the latch pin. Slowly release the latch knob.
2. Hold the treadmill firmly with both hands, and lower the treadmill to the floor. **Do not drop the treadmill frame to the floor. To decrease the possibility of injury, bend your legs and keep your back straight.**

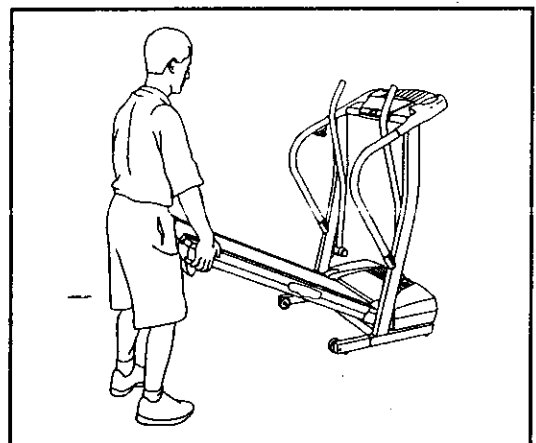
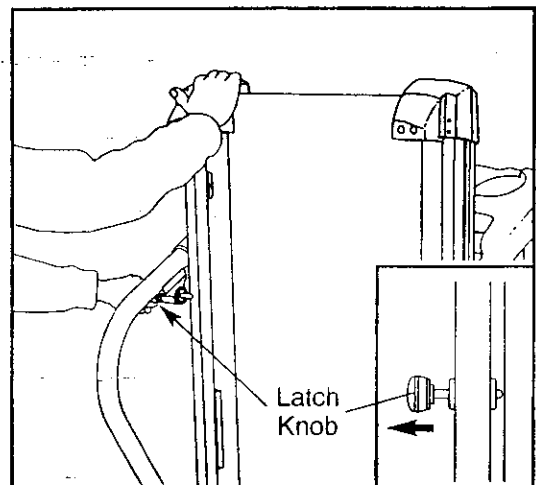

# TROUBLESHOOTING

Most treadmill problems can be solved by following the simple steps below. Find the symptom that applies, and follow the steps listed. If further assistance is needed, call toll-free 1-800-4-MY-HOME® (1-800-469-4663).

**PROBLEM:** The power does not turn on

**SOLUTION:** a. Make sure that the power cord is plugged into a surge suppressor, and that the surge suppressor is plugged into a properly grounded outlet (see page 8). Use only a single-outlet surge suppressor that meets all of the specifications described on page 8. Important: The treadmill is not compatible with GFCI-equipped outlets.

b. After the power cord has been plugged in, make sure that the key is fully inserted into the console.

c. Check the on/off circuit breaker located on the treadmill frame near the power cord. If the switch protrudes as shown, the on/off circuit breaker has tripped. To reset the on/off circuit breaker, wait for five minutes and then press the switch back in.

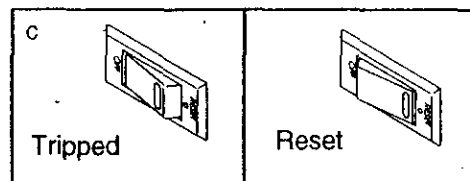

**PROBLEM:** The power turns off during use

**SOLUTION:** a. Check the on/off circuit breaker located on the treadmill frame near the power cord (see the drawing above). If the on/off circuit breaker has tripped, wait for five minutes and then press the switch back in.

b. Make sure that the power cord is plugged in. If the power cord is plugged in, unplug it, wait for five minutes, and then plug it back in.

c. Remove the key from the console. Reinsert the key fully into the console.

d. If the treadmill still will not run, please call toll-free 1-800-4-MY-HOME® (1-800-469-4663).

**PROBLEM:** The displays of the console do not function properly

**SOLUTION:** a. Remove the key from the console and **UNPLUG THE POWER CORD**. Remove the two 3/4" Screws (2) from the hood, and carefully pivot the Hood (1) off.

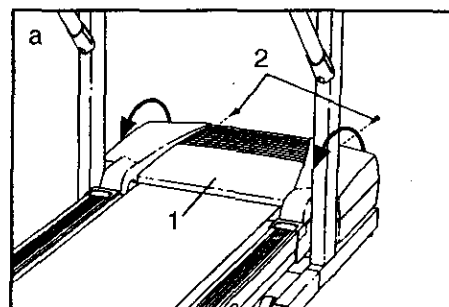

Locate the Reed Switch (10) and the Magnet (18) on the left side of the Pulley (17). Turn the Pulley until the Magnet is aligned with the Reed Switch. **Make sure that the gap between the Magnet and the Reed Switch is about 1/8"**. If necessary, loosen the Screw (56) and move the Reed Switch slightly. Retighten the Screw. Re-attach the Hood, and run the treadmill for a few minutes to check for a correct speed reading.

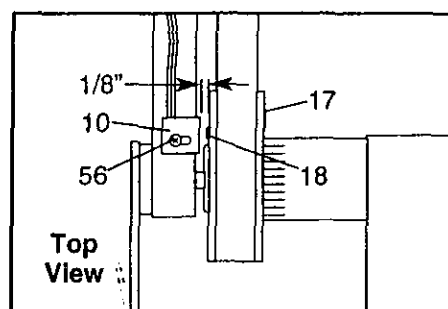

**PROBLEM: The walking belt slows when walked on**

**SOLUTION:** a. Use only a single-outlet surge suppressor that meets all of the specifications described on page 8.

- b. If the walking belt is overtightened, treadmill performance may decrease and the walking belt may become damaged. Remove the key and **UNPLUG THE POWER CORD**. Using the allen wrench, turn both rear roller adjustment bolts counterclockwise, 1/4 of a turn. When the walking belt is properly tightened, you should be able to lift each side of the walking belt 2 to 3 inches off the walking platform. Be careful to keep the walking belt centered. Plug in the power cord, insert the key, and run the treadmill for a few minutes. Repeat until the walking belt is properly tightened.

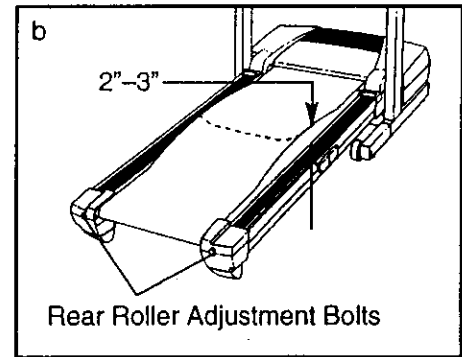

- c. If the walking belt still slows when walked on, please call toll-free 1-800-4-MY-HOME® (1-800-469-4663).

**PROBLEM: The walking belt is off-center or slips when walked on**

**SOLUTION:** a. If the walking belt is off-center, first remove the key and **UNPLUG THE POWER CORD**. If the walking belt has shifted to the left, use the allen wrench to turn the left rear roller bolt clockwise 1/2 of a turn; if the walking belt has shifted to the right, turn the bolt counterclockwise 1/2 of a turn. Be careful not to overtighten the walking belt. Plug in the power cord, insert the key, and run the treadmill for a few minutes. Repeat until the walking belt is centered.

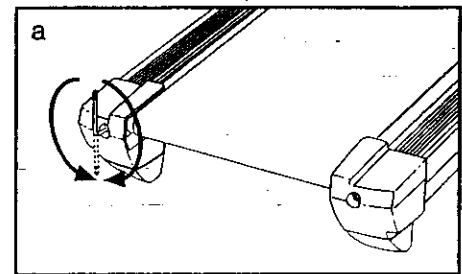

- b. If the walking belt slips when walked on, first remove the key and **UNPLUG THE POWER CORD**. Using the allen wrench, turn both rear roller bolts clockwise, 1/4 of a turn. When the walking belt is correctly tightened, you should be able to lift each side of the walking belt 2 to 3 inches off the walking platform. Be careful to keep the walking belt centered. Plug in the power cord, insert the key, and carefully walk on the treadmill for a few minutes. Repeat until the walking belt is properly tightened.

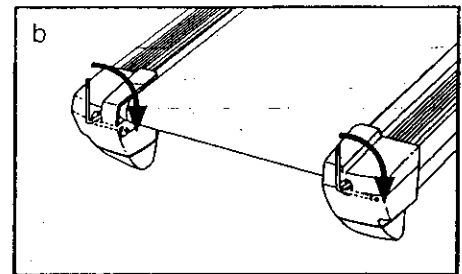

**PROBLEM: ONE OF THE UPPER BODY ARMS SQUEAKS DURING USE**

**SOLUTION:** a. Correcting this problem requires a small amount of white marine grease, available at most hardware stores. Turn the Resistance Knob (109) counterclockwise until it can be removed. Remove the Resistance Cone (108) and the Upper Body Arm (117), along with the 3/8" Washers (110), Spring Washer (111), Thrust Washers (112), and Thrust Bearing (113). (Note: If the Resistance Sleeve [107] comes out of the Resistance Bracket [105], press it back in.) Apply a **thin layer** of white marine grease to the outer surface of the Resistance Cone (108). Reattach all parts in the order shown at the right.

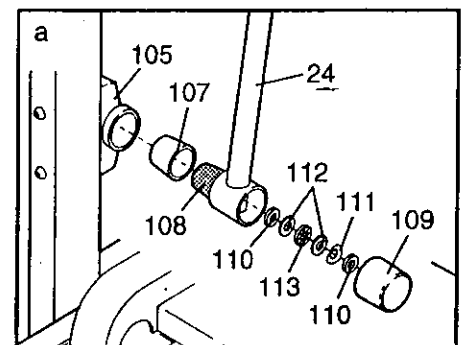

# CONDITIONING GUIDELINES

**⚠ WARNING:** Before beginning this or any exercise program, consult your physician. This is especially important for individuals over the age of 35 or individuals with pre-existing health problems.

The pulse sensor is not a medical device. Various factors, including your movement, may affect the accuracy of heart rate readings. The sensor is intended only as an exercise aid in determining heart rate trends in general.

The following guidelines will help you to plan your exercise program. For more detailed exercise information, obtain a reputable book or consult your physician.

## EXERCISE INTENSITY

Whether your goal is to burn fat or to strengthen your cardiovascular system, the key to achieving the desired results is to exercise with the proper intensity. The proper intensity level can be found by using your heart rate as a guide. The chart below shows recommended heart rates for fat burning and aerobic exercise.

HEART RATE TRAINING ZONES							
AEROBIC	165	155	145	140	130	125	115
MAX FAT BURN	145	138	130	125	118	110	103
FAT BURN	125	120	115	110	105	95	90
Age	20	30	40	50	60	70	80

To find the proper heart rate for you, first find your age near the bottom of the chart (ages are rounded off to the nearest ten years). Next, find the three numbers above your age. The three numbers define your "training zone." The lower two numbers are recommended heart rates for fat burning; the higher number is the recommended heart rate for aerobic exercise.

To measure your heart rate during exercise, use the pulse sensor. If your heart rate is too high or too low, adjust the speed and incline of the treadmill.

### Fat Burning

To burn fat effectively, you must exercise at a relatively low intensity level for a sustained period of time. During the first few minutes of exercise, your body uses easily accessible *carbohydrate calories* for en-

ergy. Only after the first few minutes does your body begin to use stored *fat calories* for energy. If your goal is to burn fat, adjust the speed and incline of the treadmill until your heart rate is near the lowest number in your training zone.

For maximum fat burning, adjust the speed and incline of the treadmill until your heart rate is near the middle number in your training zone.

### Aerobic Exercise

If your goal is to strengthen your cardiovascular system, your exercise must be "aerobic." Aerobic exercise is activity that requires large amounts of oxygen for prolonged periods of time. This increases the demand on the heart to pump blood to the muscles, and on the lungs to oxygenate the blood. For aerobic exercise, adjust the speed and incline of the treadmill until your heart rate is near the highest number in your training zone.

## WORKOUT GUIDELINES

Each workout should include the following three parts:

**A Warm-up**—Start each workout with 5 to 10 minutes of stretching and light exercise. A proper warm-up increases your body temperature, heart rate and circulation in preparation for exercise.

**Training Zone Exercise**—After warming up, increase the intensity of your exercise until your pulse is in your training zone for 20 to 60 minutes. (During the first few weeks of your exercise program, do not keep your pulse in your training zone for longer than 20 minutes.) Breathe regularly and deeply as you exercise—never hold your breath.

**A Cool-down**—Finish each workout with 5 to 10 minutes of stretching to cool down. This will increase the flexibility of your muscles and will help prevent post-exercise problems.

## EXERCISE FREQUENCY

To maintain or improve your condition, complete three workouts each week, with at least one day of rest between workouts. After a few months, you may complete up to five workouts each week if desired. The key to success is to make exercise a regular and enjoyable part of your everyday life.



## SUGGESTED STRETCHES

The correct form for several basic stretches is shown at the right. Move slowly as you stretch—never bounce.

### 1. Toe Touch Stretch

Stand with your knees bent slightly and slowly bend forward from your hips. Allow your back and shoulders to relax as you reach down toward your toes as far as possible. Hold for 15 counts, then relax. Repeat 3 times. Stretches: Hamstrings, back of knees and back.

### 2. Hamstring Stretch

Sit with one leg extended. Bring the sole of the opposite foot toward you and rest it against the inner thigh of your extended leg. Reach toward your toes as far as possible. Hold for 15 counts, then relax. Repeat 3 times for each leg. Stretches: Hamstrings, lower back and groin.

### 3. Calf/Achilles Stretch

With one leg in front of the other, reach forward and place your hands against a wall. Keep your back leg straight and your back foot flat on the floor. Bend your front leg, lean forward and move your hips toward the wall. Hold for 15 counts, then relax. Repeat 3 times for each leg. To cause further stretching of the achilles tendons, bend your back leg as well. Stretches: Calves, achilles tendons and ankles.

### 4. Quadriceps Stretch

With one hand against a wall for balance, reach back and grasp one foot with your other hand. Bring your heel as close to your buttocks as possible. Hold for 15 counts, then relax. Repeat 3 times for each leg. Stretches: Quadriceps and hip muscles.

### 5. Inner Thigh Stretch

Sit with the soles of your feet together and your knees outward. Pull your feet toward your groin area as far as possible. Hold for 15 counts, then relax. Repeat 3 times. Stretches: Quadriceps and hip muscles.

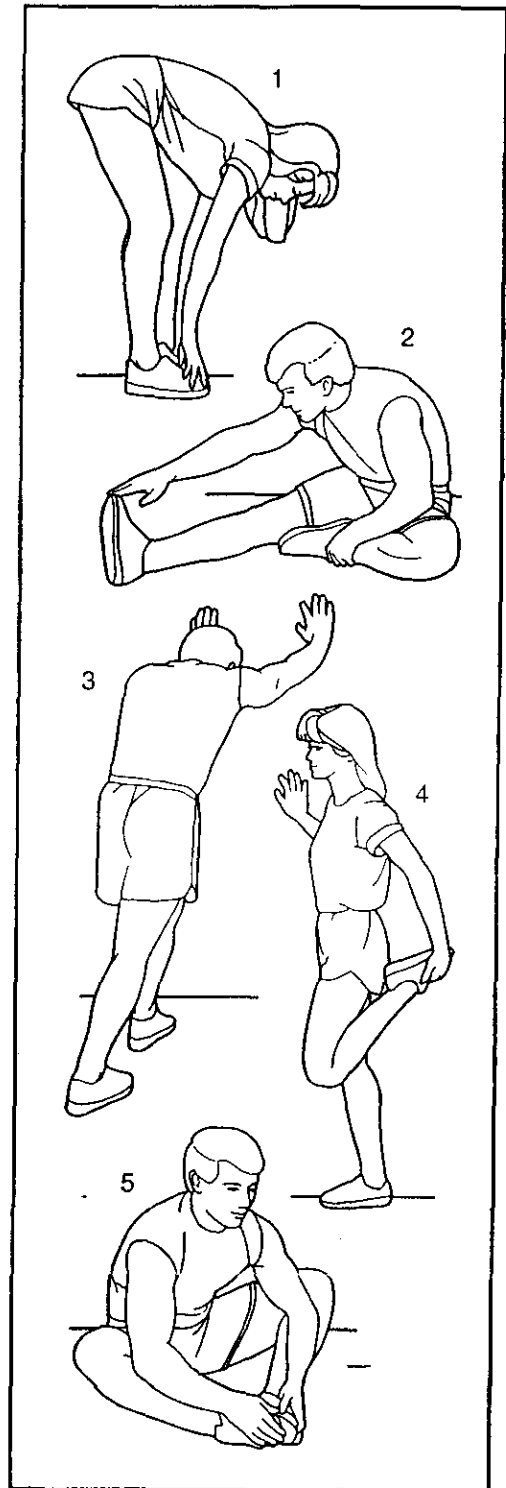

# PART IDENTIFICATION CHART

Remove this chart and use it to identify small parts during assembly. Save this chart and the EXPLODED DRAWING/PART LIST for future reference.

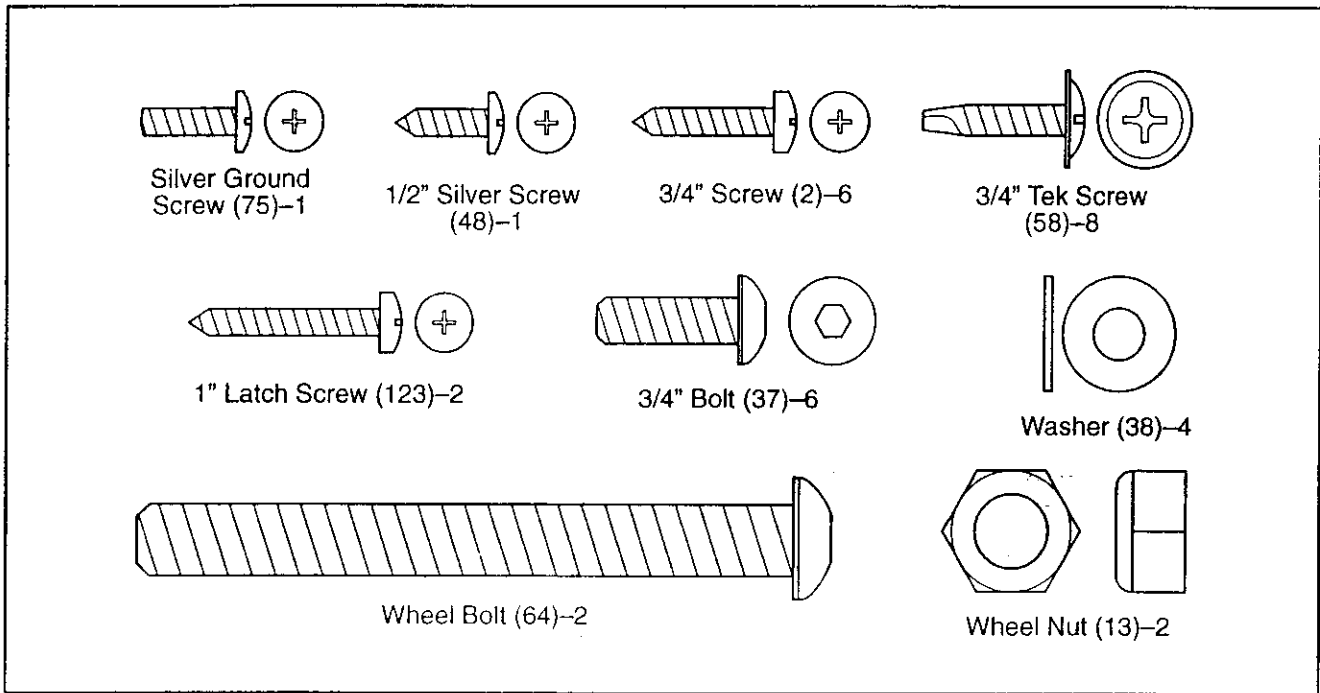

# PART LIST—Model No. 831.293040

R0303A

Key No.	Qty.	Description	Key No.	Qty.	Description	Key No.	Qty.	Description
1	1	Hood	45	4	Resistance Bracket Bolt	91	1	Right Rear Endcap Pad
2	13	3/4" Screw	46	1	Bookrack	92	2	Rear Roller Adjustable Bolt
3	1	Motor Belt	47	1	Console Base	93	1	Right Rear Endcap
4	1	Motor Tension Bolt	48	1	1/2" Silver Screw	94	1	Allen Wrench
5	5	Flat Washer	49	2	1/2" Console Screw	95	1	Left Rear Endcap
6	1	Motor Star Washer	50	1	Key/Clip	96	1	Walking Belt
7	1	Flywheel	51	1	Incline Motor	97	1	Walking Platform
8	1	Motor	52	1	Incline Bracket	98	1	Right Foot Rail
9*	1	Motor Assembly	53	2	Incline Motor Bolt	99	1	Left Rear Endcap Pad
10	1	Reed Switch	54	2	Clevis Pin	100	1	Rear Roller
11	1	Latch Warning Decal	55	2	Cotter Pin	101	2	Plastic Tie
12	2	Frame Spacer	56	1	Motor Controller Wire	102	6	Rear Endcap Screw
13	5	Frame Pivot Nut/Motor Nut	57	4	Base Pad	103	1	Motor Mount Bracket
14	2	Frame Pivot Bolt	58	12	3/4" Tek Screw	104	2	Resistance Bolt
15	4	Walking Platform Screw	59	1	Controller	105	2	Resistance Bracket
16	1	Left Foot Rail	60	1	Lift Frame	106	4	Star Washer
17	1	Front Roller/Pulley	61*	2	Extension Leg Assembly	107	2	Resistance Sleeve
18	1	Magnet	62	2	Warning Decal	108	2	Resistance Cone
19	1	Motor Pivot Bolt	63	2	Extension Leg	109	2	Resistance Knob
20	2	Motor Bracket Bolt	64	2	3 1/2" Bolt	110	4	3/8" Washer
21	1	Right Foot Rail Endcap	65	4	Base Endcap	111	2	Spring Washer
22	2	Belly Pan Clip	66	2	Wheel	112	4	Thrust Washer
23	1	Front Roller Adjustment Bolt	67	1	Console Warning Decal	113	2	Thrust Bearing
24	1	Left Upper Body Arm w/Foam Grip	68	4	8" Cable Tie	114	2	Foam Grip
25	1	Right Upper Body Arm w/Foam Grip	69	1	Base	115	1	Power Board w/Clips
26	6	Ground Screw	70	1	Grommet	116	4	Plastic Stand-off
27	1	Power Board	71	1	Left Handrail	117	1	Electronic Bracket
28	1	Motor Tension Nut	72	1	Right Handrail	118	1	Choke
29	1	Latch Spacer	73	4	Cage Nut	119	1	Static Decal
30	1	Latch Knob	74	1	Left Foot Rail Endcap	120	1	Audio Cable
31*	1	Latch Knob Assembly	75	1	1/2" Silver Ground Screw	121	1	iFIT.com Plug
32	1	Spring	76	2	Handrail Cap	122	2	Upright Insert
33	1	Latch Pin Collar	77	4	Belly Pan Screw	123	2	1" Latch Screw
34	1	Latch Pin Clip	78	1	On/Off Circuit Breaker	#	1	8" Blue Wire, 2F
35	1	Latch Pin	79	1	Power Cord	#	1	4" Blue Wire, 2F
36	1	Storage Latch	80	1	Power Cord Grommet	#	1	4" Blue Wire, M/F
37	6	3/4" Bolt	81	1	Belly Pan	#	1	4" White Wire, M/F
38	10	Washer	82	2	Belt Guide	#	1	8" White Wire, 2F
39	2	Crossbar Screw	83	4	Belt Guide Screw	#	1	8" Green Wire, 2 Ring
40	1	Crossbar	84	4	Plastic Fastener	#	1	8" Red Wire, M/F
41	1	5/32" Allen Wrench	85	2	Isolator Cushion	#	1	User's Manual
42	1	Wire Harness	86	1	Frame	*Includes all parts shown in the box #These parts are not illustrated  <b>If a part is missing, call toll-free 1-800-999-3756.</b>		
43	1	Console	87	4	Releasable Tie			
44	1	Wire Cover	88	1	Incline Motor Wire			
			89	2	Cable Tie Clamp			
			90	1	Ground Wire			



## Get it fixed, at your home or ours!

### Your Home

For repair – **in your home** – of all major brand appliances, lawn and garden equipment, or heating and cooling systems, **no matter who made it, no matter who sold it!**

For the replacement parts, accessories, and user's manuals that you need to do-it-yourself.

For Sears professional installation of home appliances and items like garage door openers and water heaters.

**1-800-4-MY-HOME®**

(1-800-469-4663)

[www.sears.com](http://www.sears.com)

Anytime, day or night

(U.S.A. and Canada)

[www.sears.ca](http://www.sears.ca)

### Our Home

For repair of carry-in products like vacuums, lawn equipment, and electronics, call or go on-line for the location of your nearest **Sears Parts and Repair Center.**

**1-800-488-1222** Anytime, day or night (U.S.A. only)

[www.sears.com](http://www.sears.com)

To purchase a protection agreement (U.S.A.) or maintenance agreement (Canada) on a product serviced by Sears:

**1-800-827-6655** (U.S.A.)

**1-800-361-6665** (Canada)

Para pedir servicio de reparación a domicilio, y para ordenar piezas:

**1-888-SU-HOGAR<sup>SM</sup>** (1-888-784-6427)

# SEARS

® Registered Trademark / ™ Trademark / <sup>SM</sup> Service Mark of Sears, Roebuck and Co.  
® Marca Registrada / ™ Marca de Fábrica / <sup>SM</sup> Marca de Servicio de Sears, Roebuck and Co.

## FULL 90 DAY WARRANTY

For 90 days from the date of purchase, if failure occurs due to defect in material or workmanship in this Sears Treadmill Exerciser, contact the nearest Sears Service Center throughout the United States and Sears will repair or replace the Treadmill Exerciser, free of charge.

This warranty does not apply when the Treadmill Exerciser is used commercially or for rental purposes.

This warranty gives you specific legal rights, and you may also have other rights which vary from state to state.

**Sears, Roebuck and Co., Dept. 817WA, Hoffman Estates, IL 60179**