

Owner's Manual

CRAFTSMAN®

FRONT BUMPER

Model No. 486.24599

Fits 917 Series LT/YT/GT Tractors

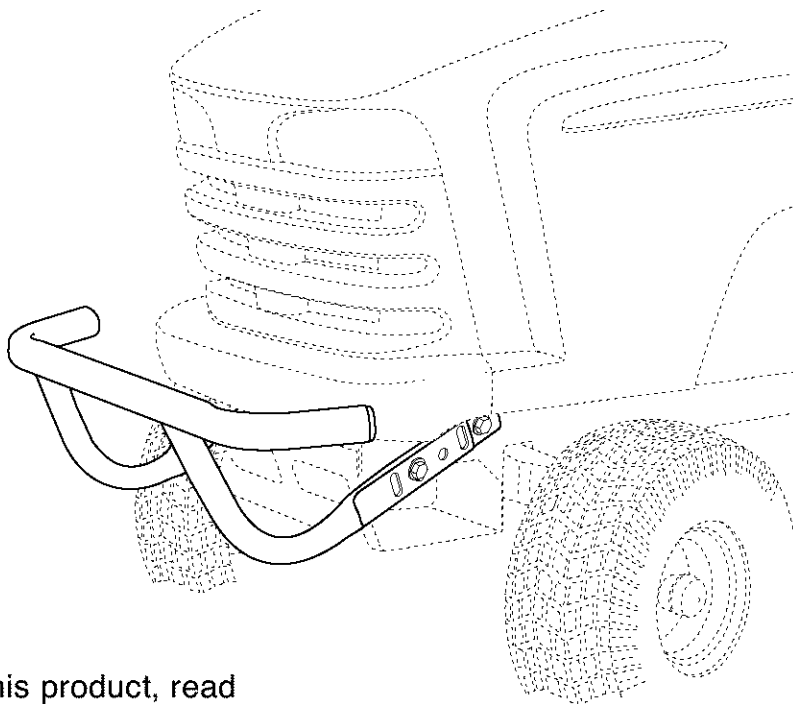

CAUTION:

Before using this product, read this manual and follow all Safety Rules and Operating Instructions.

IMPORTANT - READ THIS FIRST!!!

For Missing Parts or Assembly Questions
Please Call 217-728-8388
Mon.-Fri. 7 am - 5 pm CST.

FAX 217-728-2032 or e-mail info@agri-fab.com

Missing parts will be sent UPS in 24 hours directly to your home.

- Safety
- Assembly
- Operation
- Maintenance
- Parts

Sears, Roebuck and Co., Hoffman Estates, IL 60179 U.S.A.
www.sears.com/craftsman



SAFETY



Any power equipment can cause injury if operated improperly or if the user does not understand how to operate the equipment. Exercise caution at all times, when using power equipment.

- Refer to your tractor owners manual for "Rules For Safe Operation".



Look for this symbol to point out important safety precautions. It mean--**Attention!! Become alert!! Your safety is involved.**

ASSEMBLY

Your bumper carton contains parts listed below. Identify and lay out all parts shown.

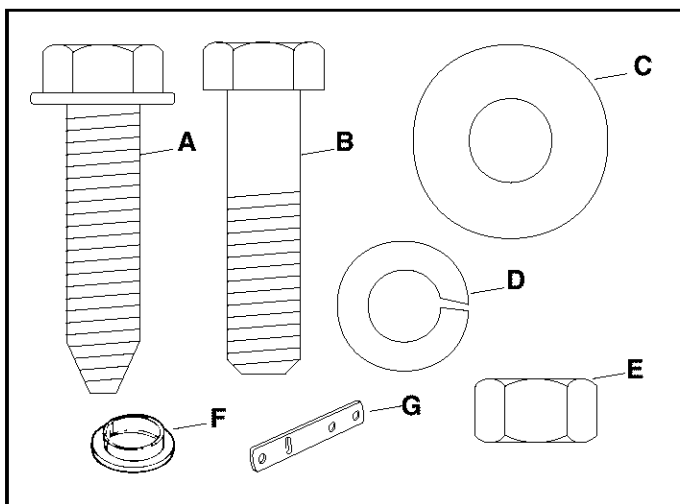

HARDWARE SHOWN FULL SIZE

Ref. No.	Part No.	Qty.	Description
A	48894	2	Hex Bolt, Self Threading 3/8-16 x 1-1/2"
B	43062	4	Hex Bolt, 3/8-16 x 1-1/2"
C	43070	4	Flat Washer, 3/8"
D	43003	4	Lock Washer, 3/8"
E	43015	4	Hex Nut, 3/8-16 Thd.
F	44742	2	Plug
G	24655	2	Bumper Extension Brackets
	64623	1	Bumper Assembly

TOOLS REQUIRED

- (2) 9/16" Open End or Box Wrenches

- Place plug on a work bench or solid table. Set end of bumper onto plug until it rests on short step of plug. Using even pressure, push down on bumper until end of bumper slips over plug. See figure 1.

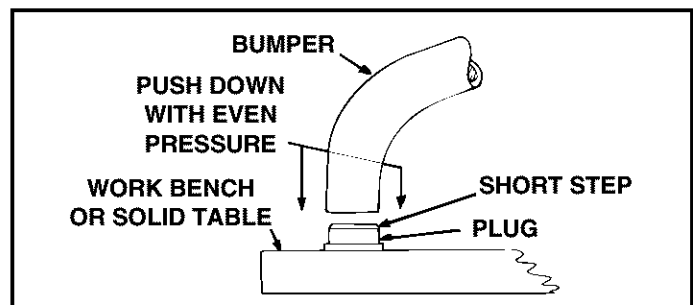

FIGURE 1

(LT & YT) LAWN TRACTORS



CAUTION! Muffler is hot! Allow engine to cool down before proceeding with bumper installation.

- Remove tractor hood.
- If your tractor has a heat shield like the one in figure 2 remove it to attach bumper, then reinstall shield.

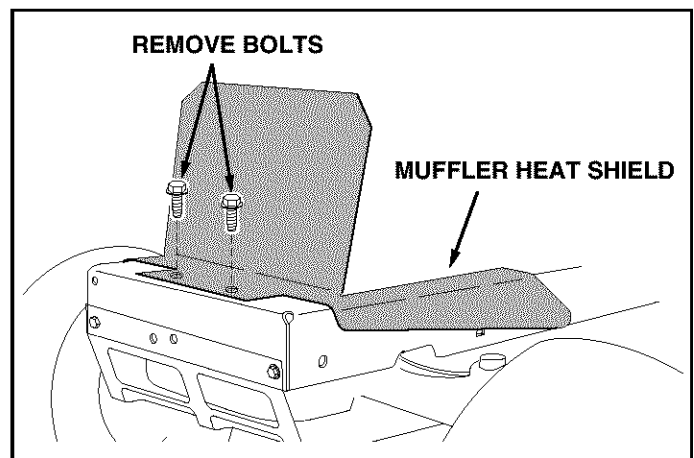

FIGURE 2

- Remove bolts from mounting holes in tractor frame. See figure 3.
- Attach extension bracket to rear mounting hole in frame using a 3/8" x 1-1/2" hex bolt, flat washer and lock washer. Be sure bracket is turned as shown in figure 3. Do not tighten yet.
- Slide bumper onto extension brackets. Align slots in bumper and extension brackets and fasten to frame using two 3/8" x 1-1/2" hex bolts, flat washers and lock washers. Push bumper down for hood tilt clearance and then tighten all bolts. See figure 3.

NOTE 1: If bolts cannot be inserted into or screwed into **front** mounting holes in tractor frame, use self threading bolts.

NOTE 2: If bolts can be inserted freely into mounting holes in tractor frame, they must be secured with lock washers and hex nuts on inside of tractor frame.

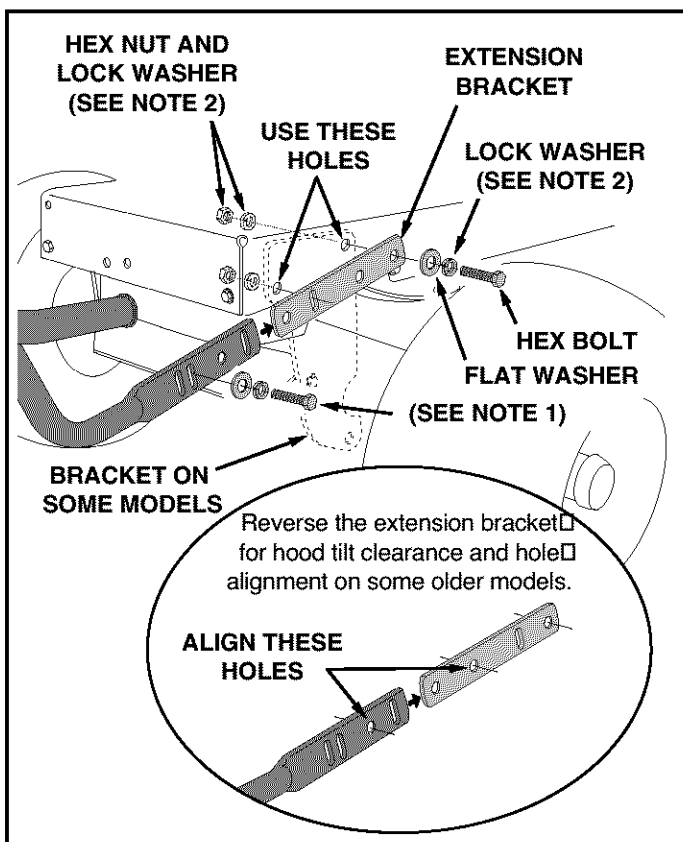

FIGURE 3

(GT) GARDEN TRACTORS



CAUTION! Muffler is hot! Allow engine to cool down before proceeding with bumper installation.

- Remove tractor hood.
- Unscrew bolts from mounting holes in tractor frame.
- **If bolts are secured by hex nuts** that you cannot reach, remove heat shield. For access to hex nuts, slide muffler down exhaust tubes to rest on top of browning shield. Replace muffler and heat shield after assembling bumper. See figure 4.

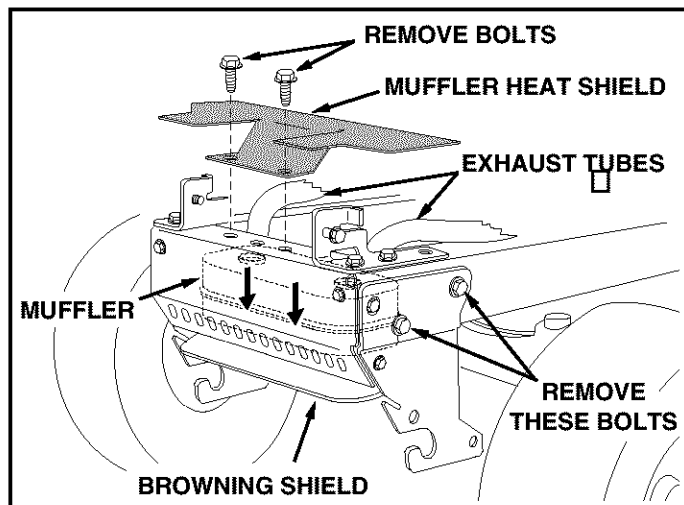

FIGURE 4

- Fasten bumper to frame using four 3/8" x 1-1/2" hex bolts, lock washers and flat washers. Do not tighten yet. See figure 5.
- Push bumper down for maximum clearance, then tilt hood forward. If hood remains stable when tilted forward, tighten the hex nuts that fasten the bumper to the frame. See figure 5.

NOTE 1: If bolts cannot be inserted into or screwed into **front** mounting holes in tractor frame, use self threading bolts.

NOTE 2: If bolts can be inserted freely into mounting holes in tractor frame, they must be secured with lock washers and hex nuts on inside of tractor frame.

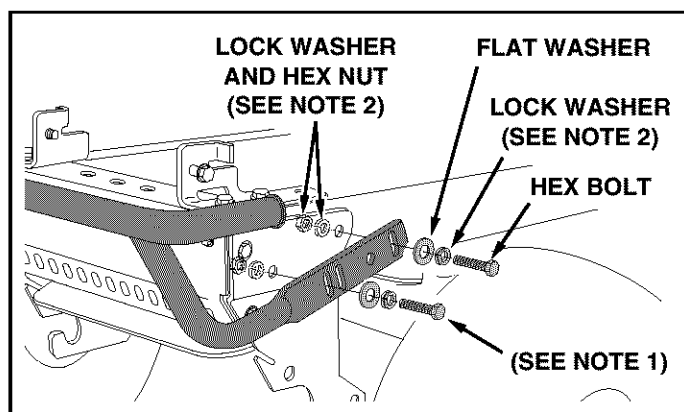

FIGURE 5

Get it fixed, at your home or ours!

For repair of major brand appliances **in your own home...**
no matter who made it, no matter who sold it!

1-800-4-MY-HOMESM Anytime, day or night
(1-800-469-4663)

www.sears.com

To bring in products such as vacuums, lawn equipment and electronics
for repair, call for the location of your nearest **Sears Parts & Repair Center.**

1-800-488-1222 Anytime, day or night

www.sears.com

For the replacement parts, accessories and owner's manuals
that you need to do-it-yourself, call **Sears PartsDirectSM!**

1-800-366-PART 6 a.m. – 11 p.m. CST,
(1-800-366-7278) 7 days a week

www.sears.com/partsdirect

To purchase or inquire about a Sears Service Agreement:

1-800-827-6655

7 a.m. – 5 p.m. CST, Mon. – Sat.

Para pedir servicio de reparación a domicilio,
y para ordenar piezas con entrega a domicilio:

1-888-SU-HOGARSM
(1-888-784-6427)

Au Canada pour service en français:

1-877-LE-FOYERSM
(1-877-533-6937)

