

---

---

# Installation Instructions

## Full Size Laundry Center Gas & Electric

Before beginning installation, carefully read these instructions. This will simplify the installation and ensure the laundry center is installed correctly and safely. Leave these instructions near the laundry center after installation for future reference.

**NOTE:** The electrical service to the laundry center must conform with local codes and ordinances and the latest edition of the *National Electrical Code, ANSI/NFPA 70*, or in Canada, the *Canadian Electrical Code, CSA C22.1*

**NOTE:** The gas service to the laundry center must conform with local codes and ordinances and the latest edition of the *National Fuel Gas Code ANSI Z223.1/NFPA 54*, or in Canada, the *Canadian Natural Gas and Propane Installation Code, CSA B149.1*.

**NOTE:** The laundry center is designed under ANSI Z21.5.1 or ANSI/UL 2158- CAN/CSA C22.2 (latest edition) for HOME USE only. This laundry center is not recommended for commercial applications such as restaurants or beauty salons, etc.

**⚠ WARNING** For your safety the information in this manual must be followed to minimize the risk of fire or explosion or to prevent property damage, personal injury or loss of life.

- Do not store or use gasoline or other flammable vapors and liquid in the vicinity of this or any other appliance.

**- WHAT TO DO IF YOU SMELL GAS**

- Do not try to light any appliance.
- Do not touch any electrical switch; do not use any phone in your building.
- Clear the room, building or area of all occupants.
- Immediately call your gas supplier from a neighbor's phone. Follow the gas supplier's instructions.
- If you cannot reach your gas supplier, call the fire department.

Installation and service must be preformed by a qualified installer, service agency or the gas supplier.

## Contents

<u>SUBJECT</u>	<u>PAGE</u>
Pre-Installation Requirements	2
Electrical Requirements	2
Water Supply Requirements	2
Drain Requirements	2
Exhaust System Requirements	3
Gas Supply Requirements	4
Location	4
Mobile Home Installation	4
Rough-In Dimensions	5
Unpacking	5
Electrical Installation	6
Grounding Requirements	6
3 & 4-Wire Connections	7
Installation	7
Replacement Parts	8

## PRE-INSTALLATION REQUIREMENTS

### Tools and Materials Required for Installation:

1. Phillips head screwdriver.
2. Channel-lock adjustable pliers.
3. Carpenter's level.
4. Flat or straight blade screwdriver.
5. Duct tape.
6. Rigid or flexible metal 4 inch (10.16 cm) duct.
7. Vent hood.
8. Pipe thread sealer (Gas).
9. Ratchet with 3/8 inch (0.96 cm) socket.

## ELECTRICAL REQUIREMENTS

### ***ELECTRIC Laundry Center***

**Circuit-** Individual 30 amp branch circuit fused with 30 amp minimum time delay fuses or circuit breakers.

**POWER SUPPLY** - 3-wire or 4-wire , 240 volt, single phase, 60 Hz, Alternating Current.

**POWER SUPPLY CORD KIT-** The laundry center **MUST** employ a 3-conductor power supply cord NEMA 10-30 type SRDT rated at 240 volt AC minimum, 30 amp, with 3 open end spade lug connectors with upturned ends or closed loop connector **OR** a 4-conductor power supply cord NEMA 14-30 type SRDT or ST (as required) rated at 240 volt AC minimum, 30 amp, with 4 open end spade lug connectors with upturned ends or closed loop connectors and marked for use with clothes dryers. If being installed in a manufactured (mobile) home, the laundry center **MUST** employ a 4-conductor power supply cord NEMA 14- 30 type SRDT or ST (as required) rated at 240 volt AC minimum, 30 amp, with 4 open end spade lug connectors with upturned ends or closed loop connectors and marked for use with clothes dryers. See ELECTRICAL CONNECTIONS. (Canada - 4-wire power supply cord is installed on laundry center.)

**OUTLET RECEPTACLE** - NEMA 10-30R (3-wire) receptacle or NEMA 14- 30R (4-wire) receptacle to be located so the power supply cord is accessible when the laundry center is in an installed position.



NEMA 10-30R



NEMA 14-30R

### ***GAS Laundry Center***

**CIRCUIT** -Individual 15 amp branch circuit fused with a 15 amp maximum time delay fuse or circuit breaker.

**POWER SUPPLY** -3 wire, 120 volt single phase, 60 Hz, Alternating Current.

**POWER SUPPLY CORD** -The gas laundry center is equipped with a 120 volt 3-wire power cord.

NOTE: Do not under any circumstances remove grounding prong from plug.

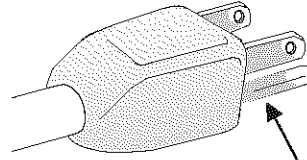

Grounding Prong

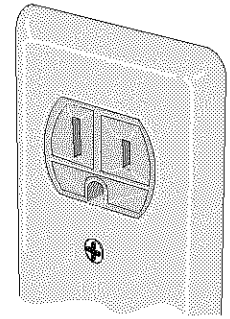

## WATER SUPPLY REQUIREMENTS

Hot and cold water faucets **MUST** be installed within 42 inches (106.68 cm) of your laundry center's water inlet. The faucets **MUST** be 3/4 inch (1.9 cm) garden hose type so inlet hoses can be connected. Water pressure **MUST** be between 10 and 120 pounds per square inch (maximum unbalance pressure, hot vs. cold, 10 psi). Your water department can advise you of your water pressure. The hot water temperature should be about 140 degrees F.

## DRAIN REQUIREMENTS

1. Drain capable of eliminating 17 gals. per minute.
2. A standpipe diameter of 1-1/4 inches (3.18 cm) minimum.
3. The standpipe height above the floor should be:  
Minimum height: 33 inches (83.82 cm)  
Maximum height: 96 inches (244 cm)

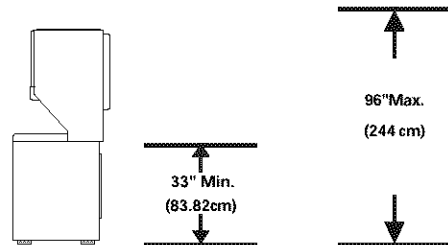

NOTE:For installations requiring a longer drain hose, have a qualified technician install a longer hose *PIN* 131461201, available from an authorized parts distributor. For drain systems in the floor, install a siphon break kit, available from your local hardware store .

## EXHAUST SYSTEM REQUIREMENTS

Use only 4 inch (10.16 cm) diameter (minimum) **rigid or flexible metal duct** and approved vent hood which has a swing-out damper(s) that opens when the dryer is in operation. When the dryer stops, the damper(s) automatically closes to prevent drafts and the entrance of insects and rodents. To avoid restricting the outlet, maintain a minimum of 12 inches (38.5 cm) clearance between the vent hood and the ground or any other obstruction.

**WARNING** The following are specific requirements for proper and safe operation of your laundry center. Failure to follow these instructions can create excessive drying times and fire hazards.

**WARNING** Do not use plastic flexible duct to exhaust the dryer. Excessive lint can build up inside the exhaust system and create a fire hazard and restrict air flow. Restricted air flow will increase drying times. If your present system is made up of plastic duct or metal foil duct, replace it with a rigid or flexible metal duct. **Ensure the present duct is free of any lint prior to installing** laundry center dryer duct.

**WARNING** If the dryer is not exhausted outdoors, some fine lint will be expelled into the laundry area. An accumulation of lint in any area of the home can create a health and fire hazard. **The dryer exhaust system MUST be exhausted to the outside of the dwelling!**

**WARNING** Do not allow combustible materials (for example: clothing, draperies/curtains, paper) to come in contact with the exhaust system. The dryer **MUST NOT** be exhausted into a chimney, a wall, a ceiling, or any concealed space of a building which can accumulate lint, resulting in a fire hazard.

**WARNING** Do not exceed the length of duct pipe or number of elbows allowed in the "EXHAUST DUCT LENGTHS" chart. Lint can accumulate in the system, plugging the system and creating a fire hazard, as well as increasing drying times.

**WARNING** Do not screen the exhaust ends of the vent system, nor use any screws or rivets to assemble the exhaust system. Lint can become caught in the screen, on the screws or rivets, clogging the exhaust system and creating a fire hazard as well as increasing drying times. Use an approved vent hood to terminate the duct outdoors, and seal all joints with duct tape. All male duct pipe fittings **MUST** be installed downstream with the flow of air.

**WARNING** **Explosion hazard.** Do not install the laundry center where gasoline or other flammables are kept or stored. If the laundry center is installed in a garage, it must be a minimum of 18 inches (45.7 cm) above the floor. Failure to do so can result in death, explosion, fire or burns.

The exhaust system back pressure **MUST** not exceed 0.6 inches (1.52 cm) of water column, measured with an inclined manometer at the point the exhaust connects to the dryer.

The exhaust system should be inspected and cleaned a minimum of every two years with normal usage. The more the dryer is used, the more often you should check the exhaust system and vent hood for proper operation.

The maximum length of the exhaust system depends upon the type of duct used, number of elbows and type of exhaust hood.

The maximum length for both rigid and flexible duct is shown in the chart below.

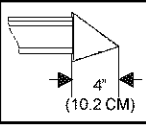
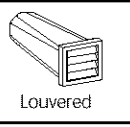
EXHAUST DUCT LENGTHS		
Number of 90° Turns	EXHAUST HOOD TYPE	
	 4" (10.2 CM)	 Louvered
<b>MAXIMUM LENGTH OF 4-INCH (10.2 CM) DIAMETER RIGID METAL DUCT</b>		
0	56 ft. (17.07 m)	42 ft. (12.8 m)
1	46 ft. (14.02 m)	36 ft. (10.97 m)
2	34 ft. (10.36 m)	28 ft. (8.53 m)
3	32 ft. (9.75 m)	18 ft. (5.48 m)
<b>MAXIMUM LENGTH OF 4-INCH (10.2 CM) DIAMETER FLEXIBLE METAL DUCT</b>		
0	30 ft. (9.14 m)	22 ft. (6.7 m)
1	22 ft. (6.7 m)	14 ft. (4.27 m)
2	16 ft. (4.88 m)	10 ft. (3.05 m)
3	10 ft. (3.05 m)	5 ft. (1.5 m)

The laundry center may be exhausted four (4) ways with rear **flush** installation:

- Straight back**
- Down** (8 inch [20.32 cm] length of 4 inch [10.16 cm] rigid duct and 1 elbow down)
- Left** (8 inch [20.32 cm] length of 4 inch [10.16 cm] rigid duct, 1 elbow down and 1 elbow left)
- Right** (8 inch [20.32 cm] length of 4 inch [10.16 cm] rigid duct, 1 elbow down and 1 elbow right)

To exhaust up, add an 11 inch (27.94 cm) length of standard 4 inch (10.16 cm) diameter duct and a 90° elbow. The unit will be positioned about 4½ inches (11.43 cm) away from the wall (flush to wall exhausting may be done by going below the dryer then sideways).

An exhaust hood positioned to line up with the dryer exhaust can be installed directly through the outside wall. To exhaust to the side or down, add an 8 inch (20.32 cm) length of standard 4 inch (10.16 cm) diameter duct and a 90° elbow.

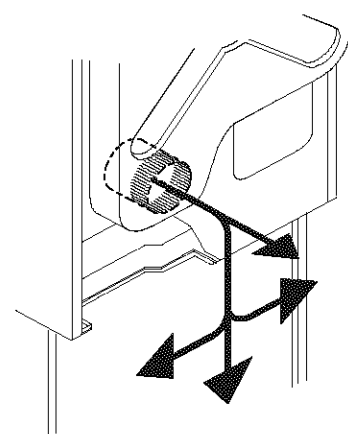

## GAS SUPPLY REQUIREMENTS

1. Installation **MUST** conform with local codes, or in the absence of local codes, with the National Fuel Gas Code, ANSI Z223.1 (latest edition) or in Canada, the current AN/CGA B149.
2. The gas supply line should be of 1/2 inch (1.27 cm) pipe.
3. If codes allow, flexible metal tubing may be used to connect your dryer to the gas supply line. The tubing **MUST** be constructed of stainless steel or plastic-coated brass.
4. The gas supply line **MUST** have an individual shutoff valve.
5. A 1/8 inch (0.32 cm) N. P. T. plugged tapping, accessible for test gage connection, **MUST** be installed immediately upstream of the gas supply connection to the dryer.
6. The dryer and its individual shutoff valve **MUST** be disconnected from the gas supply piping system during any pressure testing of the gas supply piping system at test pressures equal to or less than 1/2 psig (3.45 kPa).
7. The dryer **MUST** be isolated from the gas supply piping system by closing its individual manual shutoff valve during any pressure testing of the gas supply piping system at test pressures equal to or less than 1/2 psig (3.45 kPa).

## LOCATION OF YOUR LAUNDRY CENTER

### DO NOT INSTALL YOUR LAUNDRY CENTER:

1. In an area exposed to dripping water or outside weather conditions.
2. In an area where it will come in contact with curtains or drapes.
3. On carpet. Floor **MUST** be solid with a maximum slope of 1 inch (2.54 cm).

### INSTALLATION IN RECESS OR CLOSET

1. A laundry center installed in a bedroom, bathroom, recess or closet, **MUST** be exhausted outdoors.
2. No other fuel burning appliance shall be installed in the same closet as the **Gas** laundry center.
3. Your laundry center needs the space around it for proper ventilation.

### DO NOT INSTALL YOUR LAUNDRY CENTER IN A CLOSET WITH A SOLID DOOR.

4. A minimum of 120 square inches (774.2 square cm) of opening, equally divided at the top and bottom of the door, is required. Air openings are required to be unobstructed when a door is installed. A louvered door with equivalent air openings for the full length of the door is acceptable.

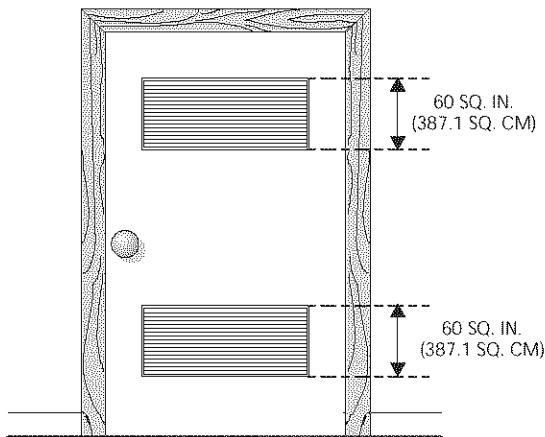

Closest Door

5. The following illustrations show minimum clearance dimensions and air openings for proper operation in a recess or closet installation.

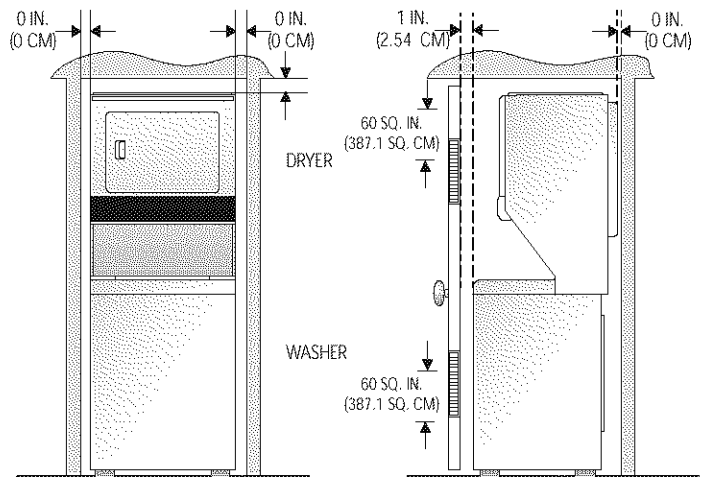

## MOBILE HOME INSTALLATION

1. Dryer **MUST** be exhausted outside (outdoors, not beneath the mobile home) using metal ducting that will not support combustion. Metal ducting must be 4 inches (10.16 cm) in diameter with no obstructions. Rigid metal duct is preferred.
2. If dryer is exhausted through the floor and area beneath the mobile home is enclosed, the exhaust system **MUST** terminate outside the enclosure with the termination securely fastened to the mobile home structure.
3. Refer to page 3 for other important venting requirements.

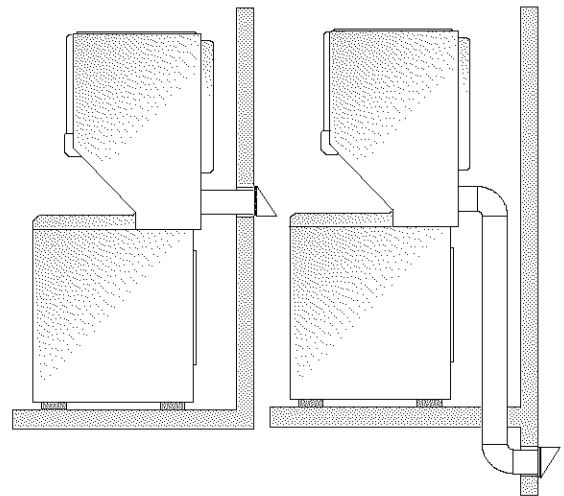

4. When installing a gas dryer into a mobile home, a provision must be made for outside make up air. This provision is to be not less than twice the area of the dryer exhaust outlet.
5. Installation **MUST** conform to current Manufactured Home Construction & Safety Standard (which is a Federal Regulation Title 24 CFR-Part 32-80) or when such standard is not applicable, with American National Standard for Mobile Homes. In Canada, the CSA Z240 is applicable.



**WARNING** The laundry center is designed under ANSI Z 21.5.1 for **HOME USE** only.

## ROUGH-IN DIMENSIONS

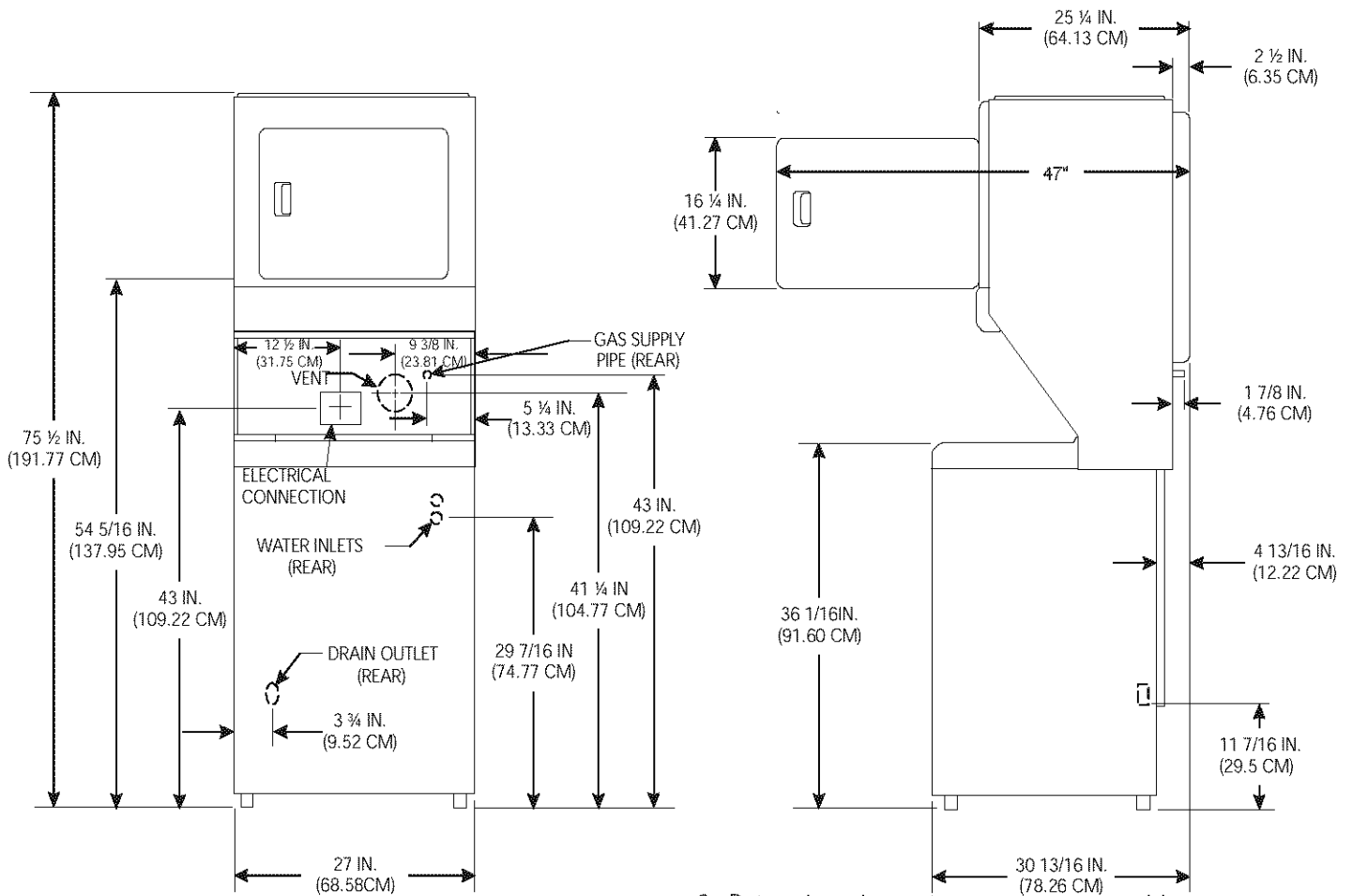

## UNPACKING

- Using the four shipping carton corner posts (two on each side), carefully lay the laundry center on its left side and remove foam shipping base.
- Using ratchet with 3/8 inch (0.96 cm) socket, remove mechanism shipping bolt and plastic spacer block from center of base.

**NOTE: If the laundry center is to be transported at a later date, the tub blocking pad, shipping bolt, and plastic spacer block should be retained.**

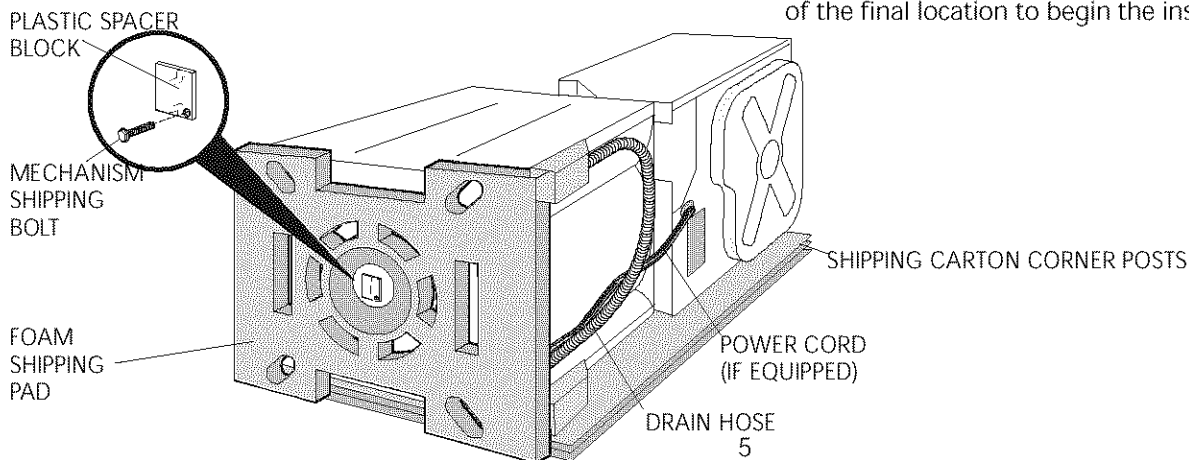

- Return laundry center to an upright position.
- Remove:
  - foam tub blocking pad.
  - foam shipping blocks from rear of unit.
  - tape from dryer door.
  - foam dryer support pads.
  - inlet hoses.
  - enclosure package.
- From the back of the washer, remove the wire shipping clips securing the drain hose and power cord (if equipped). Plastic clamps secure the drain hose to the right side of the washer backsheet. These clamps form a standpipe to prevent water syphoning. **DO NOT REMOVE THESE CLAMPS.**
- Carefully move the laundry center to within 4 feet (1.22 m) of the final location to begin the installation.

## ELECTRICAL INSTALLATION

### ***ALL ELECTRIC Laundry Centers***

**⚠ WARNING** The following are specific requirements for proper and safe electrical installation of your laundry center. Failure to follow these instructions can create electrical shock and/or a fire hazard

**⚠ WARNING** This appliance **MUST** be properly grounded. Electrical shock can result if the laundry center is not properly grounded. Follow the instructions in this manual for proper grounding.

**⚠ WARNING** Do not use an extension cord with this laundry center. Some extension cords are not designed to withstand the amounts of electrical current this laundry center utilizes and can melt, creating electrical shock and/or fire hazard. Locate the laundry center within reach of the receptacle for the length power cord to be purchased, allowing some slack in the cord. Refer to the pre-installation requirements in this manual for the proper power cord to be purchased.

**⚠ WARNING** A U.L. approved strain relief must be installed onto power cord. If the strain relief is not attached, the cord can be pulled out of the laundry center and can be cut by any movement of the cord, resulting in electrical shock.

**⚠ WARNING** Do not use an aluminum wired receptacle with a copper Wired power cord and plug (or vice versa). A chemical reaction occurs between copper and aluminum and can cause electrical shorts. **The proper wiring and receptacle is a copper wired power cord with a copper wired receptacle OR aluminum wired power cord with an aluminum wired receptacle.**

NOTE: Laundry centers operating on a 208 volt power supply will have longer drying times than laundry centers operating on a 240 volt power supply.

## GROUNDING REQUIREMENTS

### **Non-Canadian ELECTRIC Laundry Center**

**⚠ DANGER** Improper connection of the equipment grounding conductor can result in a risk of electrical shock. Check with a licensed electrician if you are in doubt as to whether the appliance is properly grounded.

For a grounded, cord-connected laundry center:

1. The laundry center **MUST** be grounded. In the event of malfunction or breakdown, grounding will reduce the risk of electrical shock by a path of least resistance for electrical current.
2. If your laundry center is equipped with a power supply cord having an equipment-grounding conductor and a grounding plug, the plug **MUST** be plugged into an appropriate, copper wired receptacle that is properly installed and grounded in accordance with all local codes and ordinances. If in doubt, call a licensed electrician.

For a permanently connected laundry center:

The laundry center **MUST** be connected to a grounded metal, permanent wiring system; or an equipment grounding conductor **MUST** be run with the circuit conductors and connected to the equipment-grounding terminal or lead on the appliance.

### **Canadian ELECTRIC Laundry Center**

**⚠ DANGER** Improper connection of the equipment grounding conductor can result in a risk of electrical shock. Check with a licensed electrician if you are in doubt as to whether the appliance is properly grounded.

For a grounded cord connected laundry center:

1. The laundry center **MUST** be grounded. In the event of malfunction or breakdown, grounding will reduce the risk of electrical shock by providing a path of least resistance for the electrical current.
2. Since your laundry center is equipped with a power supply cord having an equipment-grounding conductor and a grounding plug, the plug **MUST** be plugged into an appropriate outlet that is properly installed and grounded in accordance with all codes and ordinances. If in doubt, call a licensed electrician

### **ALL GAS Laundry Centers**

1. The laundry center, when installed, **MUST** be electrically grounded in accordance with local codes, or in the absence of local codes, with the National Electrical Codes, ANSI/NFPA (latest edition) or in Canada, CSA C22.1 Canadian Electrical Code Part 1.
2. The laundry center is equipped with a three-prong (grounding) plug for your protection against shock hazard and should be plugged directly into a properly grounded three-prong receptacle. Do not cut or remove the grounding prong from the plug.

## ELECTRICAL CONNECTIONS FOR A 3-WIRE SYSTEM

### *ELECTRIC Laundry Center*

1. Remove the screw securing the terminal block access cover to the rear panel and remove cover.
2. Install a U.L. approved strain relief connector in the entry hole on the back panel.
3. Insert a NEMA 10-30 Type SRDT, U.L. approved power cord through the strain relief.
4. Attach the power cord neutral (central wire) conductor to the silver colored center terminal on the terminal block. Tighten the screw securely.

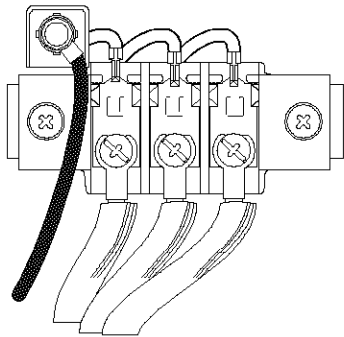
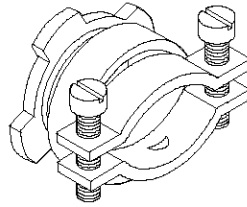

5. Attach the remaining two power cord outer conductors to the outer brass colored terminals on the terminal block. Tighten both screw securely.
6. Tighten the screws securing the cord restraint against the power cord.
7. Reinstall the terminal access cover.

## ELECTRICAL CONNECTIONS FOR A 4-WIRE SYSTEM

### *ELECTRIC Laundry Center*

1. Remove the screw securing the terminal block access cover to the rear panel and remove cover.
2. Install a U.L. approved strain relief connector in the entry hole on the back panel.
3. Remove the green neutral ground wire from the green ground screw located above the terminal block.
4. Insert a NEMA 14-30 Type ST or SRDT, U.L. approved power cord through the strain relief.
5. Attach the green power cord ground wire to the cabinet with the green ground screw

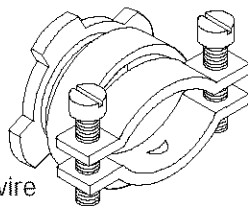

6. Attach the white (neutral) wire from the power cord and the green ground wire from the appliance harness to the silver-colored center terminal on the terminal block. Tighten the screw securely.

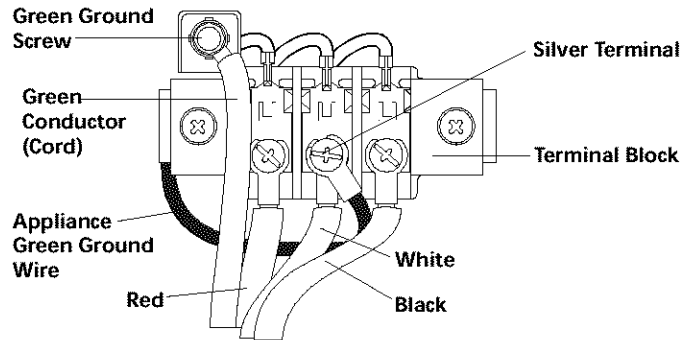

7. Attach the red and black wires from the power cord to the outer brass-colored terminals on the terminal block. Tighten both screws securely.
8. Tighten the screws securing the cord restraint firmly against the power cord.
9. Reinstall the terminal block access cover.

### INSTALLATION

1. Run some water from the hot and cold faucets to flush the water lines and remove particles that might clog up the water valve screens.
2. Check inlet hoses to ensure the rubber washers are installed in each end.
3. Carefully connect the inlet hoses to the water valve (on the left side of the washer cabinet), tighten by hand, then tighten another 2/3 turn with pliers.

**CAUTION** DO NOT CROSS THREAD OR OVERTIGHTEN THESE CONNECTIONS.

4. Determine which water faucet is the **HOT** water faucet and carefully connect the bottom inlet hose to the **HOT** water faucet, tighten by hand, then tighten another 2/3 turn with pliers. Carefully connect the top inlet hose to the **COLD** water faucet, tighten by hand, then tighten another 2/3 turn with pliers.

**CAUTION** DO NOT CROSS THREAD OR OVERTIGHTEN THESE CONNECTIONS. Turn the water on and check for leaks at both connections.

5. Carefully move the laundry center to its final location.
6. To ensure the laundry center is level and solid on all four legs, tilt the laundry center forward so the rear legs are off the ground. Gently set the laundry center back down to allow the rear legs to self adjust. Place a level on top of the washer. Check it side to side, then front to back. Screw the front leveling legs up or down to ensure the laundry center is resting solid on all four legs (no rocking of the laundry center should exist).

**NOTE:** Keep the leg extension at a minimum to prevent excessive vibration.

## 7. GAS CONNECTION *(Gas laundry centers only)*

- Remove the shipping cap from gas pipe at the rear of the dryer.  
**NOTE: DO NOT** connect the laundry center to L.P. gas service without converting the gas valve. An L.P. conversion kit (P/N 5303937053) must be installed by a qualified gas technician.
- Connect a 1/2 inch (1.27 cm) I.D. semi-rigid or approved pipe from the gas supply line to the 3/8 inch (0.96 cm) pipe located on the back of the dryer. Use a 1/2 inch (1.27 cm) to 3/8 inch (0.96 cm) reducer for the connection. Apply an approved thread sealer that is resistant to the corrosive action of liquefied gases on all pipe connections.
- Open the shutoff valve in the gas supply line.
- Test all connections by brushing on a soapy water solution.

### **NEVER TEST FOR GAS LEAKS WITH AN OPEN FLAME.**

- Form a "U" shape on the end of the drain hose with the hose pointed toward the drain. Place the formed end in a laundry tub or a standpipe and secure with a cable tie provided in the enclosure package. **WATER WILL SYPHON FROM THE WASHER IF THE ABOVE INSTRUCTIONS ARE NOT FOLLOWED.**

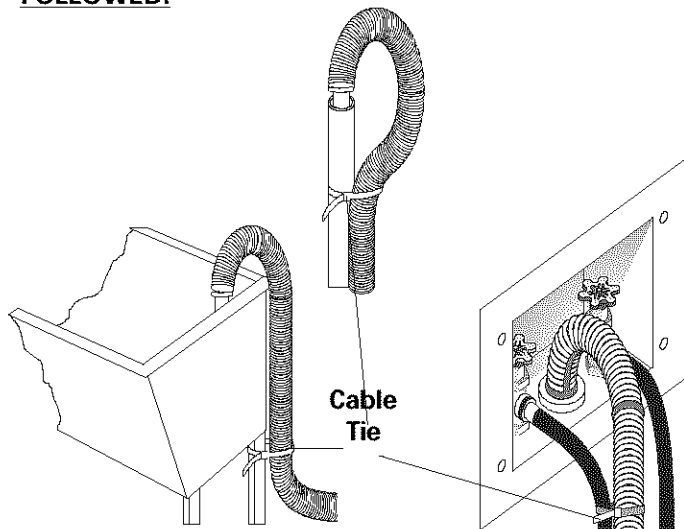

- Remove the two (2) screws securing the dryer front access panel to the dryer cabinet. Lift the panel until the tabs can be disengaged from the cabinet. Remove the panel and set aside.

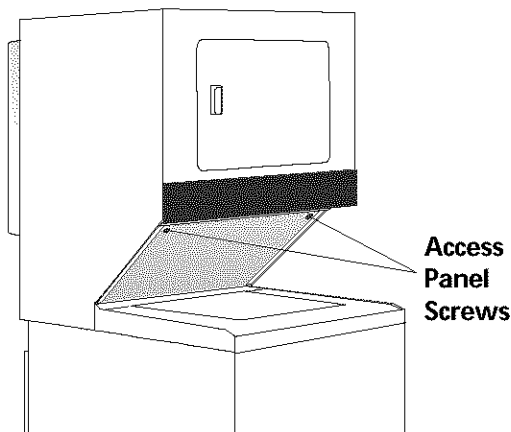

- Connect the exhaust duct to outside duct work. Use duct tape to seal all joints.
- Plug the power cord into a grounded outlet.  
**NOTE:** Check to ensure the power is off at a circuit breaker/fuse box before plugging the power cord into an outlet.
- Turn on the power at a circuit breaker/fuse box.  
**CAUTION** Before operating the dryer, make sure the dryer area is clear and free from combustible materials, gasoline, and other flammable vapors. Also see that nothing (such as boxes, clothing, etc.) obstructs the flow of combustion and ventilation air.
- Reinstall the dryer front access panel.
- Run the washer and dryer through a cycle. Check for proper operation.  
**NOTE:** On gas dryers, before the burner will light, it is necessary for the gas line to be bled of air. If the burner does not light within 45 seconds the first time the dryer is turned on, the safety switch will shut the burner off. If this happens, turn the timer to "OFF" and wait 5 minutes before making another attempt to light.
- If your laundry center does not operate, please review the "Avoid Service Checklist" located in your Owner's Guide before calling for service.
- Place these instructions in a location near the laundry center for future reference.

**NOTE:** A wiring diagram is located behind the dryer front access panel.

## REPLACEMENT PARTS

If replacement parts are needed for your laundry center, contact the source where you purchased your laundry center.

**WARNING** Destroy the carton, plastic bags, and metal band after the laundry center is unpacked. Children might use them for play. Cartons covered with rugs, bedspreads, or plastic sheets can become airtight chambers causing suffocation. Place all materials in a garbage container or make materials inaccessible to children.

**CAUTION** Label all wires prior to disconnection when servicing controls. Wiring errors can cause improper and dangerous operation. Verify proper operation after servicing.

**WARNING** The instructions in this manual and all other literature included with this laundry center are not meant to cover every possible condition and situation that may occur. Good safe practice and caution **MUST** be applied when installing, operating and maintaining any appliance.

Maximum benefits and enjoyment are achieved when all the Safety and Operating instructions are understood and practiced as a routine with your laundry tasks.