



WEIDER[®] PRO 9940

Patent Pending

Model No. 831.159730

Serial No. _____

The serial number is found in the location shown below. Write the serial number in the space above.

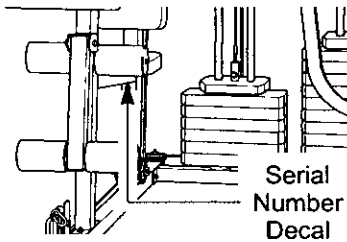

USER'S MANUAL

EXERCISE
EQUIPMENT

QUESTIONS

HELPLINE!

1-800-736-6879

SEARS, ROEBUCK AND CO.
HOFFMAN ESTATES, IL 60179

CAUTION

Read all precautions and instructions in this manual before using this equipment. Save this manual for future reference.

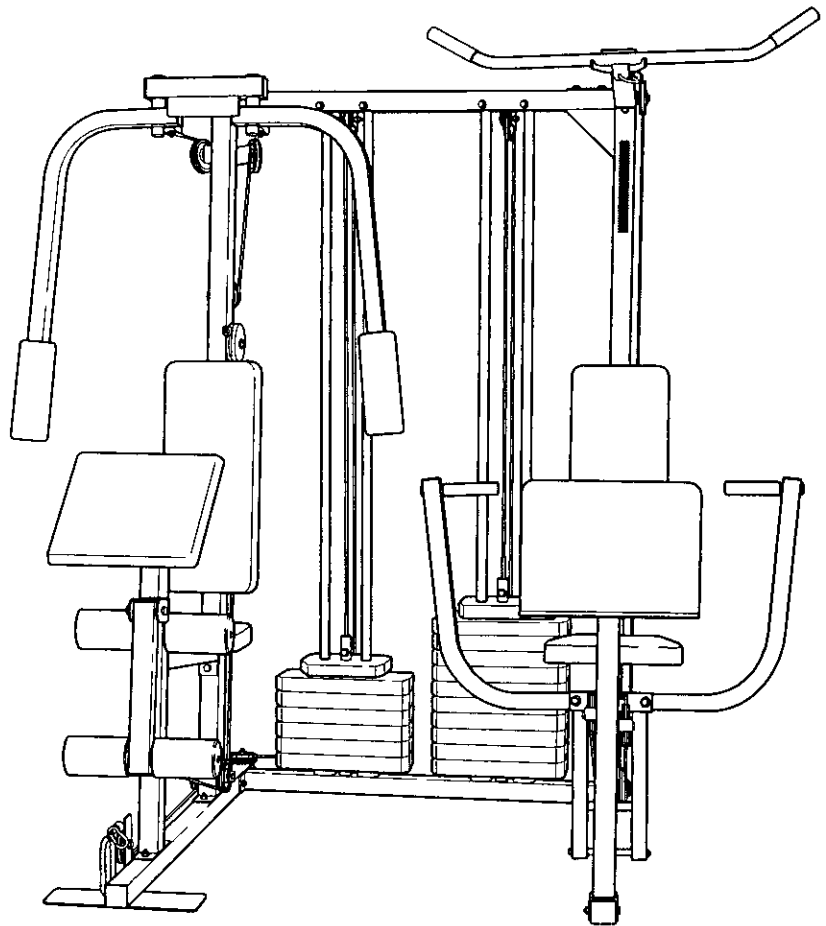

Visit our website at

www.weiderfitness.com

new products, prizes,
fitness tips, and much more!

Table of Contents

Important Precautions	2
Before You Begin	3
Assembly	4
Cable Diagrams	23
Adjustment	25
Trouble-shooting and Maintenance	26
Weight Resistance Chart	27
Ordering Replacement Parts	Back Cover
Full 90-day Warranty	Back Cover

Note. A PART LIST/EXPLODED DRAWING and a PART IDENTIFICATION CHART are attached in the center of this manual. Remove the PART LIST/EXPLODED DRAWING and the PART IDENTIFICATION CHART before beginning assembly.

Important Precautions

⚠ WARNING: To reduce the risk of serious injury, read the following important precautions before using the home gym.

1. It is the responsibility of the owner to ensure that all users of the home gym are adequately informed of all precautions.
2. Read all instructions in this manual and in the accompanying literature before using the home gym.
3. If you feel pain or dizziness at any time while exercising, stop immediately and begin cooling down.
4. Use the home gym only on a level surface. Cover the floor or carpet beneath the home gym for protection.
5. Inspect and tighten all parts often. Replace any worn parts immediately.
6. Make sure the cables remain on the pulleys at all times. If the cables bind while you are exercising, stop immediately and make sure the cables are on all of the pulleys.
7. Always stand on a foot plate when performing an exercise that could cause the home gym to tip.
8. Keep hands and feet away from moving parts.
9. Keep children under the age of 12 and pets away from the home gym at all times.
10. Always wear athletic shoes for foot protection when exercising.
11. Never release the press arms, butterfly arms, leg lever, lat bar or ab strap while weights are raised. The weights will fall with great force.
12. Always disconnect the lat bar or ab strap from the home gym when performing an exercise that does not use the attachments.
13. The home gym is intended for home use only. Do not use the home gym in a commercial, rental or institutional setting.

WARNING: Before beginning this or any exercise program, consult your physician. This is especially important for persons over the age of 35 or persons with pre-existing health problems. Read all instructions before using. SEARS assumes no responsibility for personal injury or property damage sustained by or through the use of this product.

Before You Begin

Thank you for selecting the innovative and versatile WEIDER® PRO 9940 Home Gym. The WEIDER® PRO 9940 offers a unique selection of weight stations designed to develop every major muscle group of the body. Whether your goal is to tone your body, build dramatic muscle size and strength or improve your cardiovascular system, the WEIDER® PRO 9940 makes it easy to achieve the results you want.

HELPLINE at 1-800-736-6879, Monday through Saturday, 7 a.m. until 7 p.m. Central Time (excluding holidays). To help us assist you, please note the product model number and serial number before calling. The model number is 831.159730. The serial number can be found on a decal attached to the WEIDER® PRO 9940 Home Gym (see the front cover of this manual).

For your benefit, read this manual carefully before using the WEIDER® PRO 9940 Home Gym. If you have additional questions, please call our toll-free

Please use the drawing below to familiarize yourself with the major parts and how they fit together.

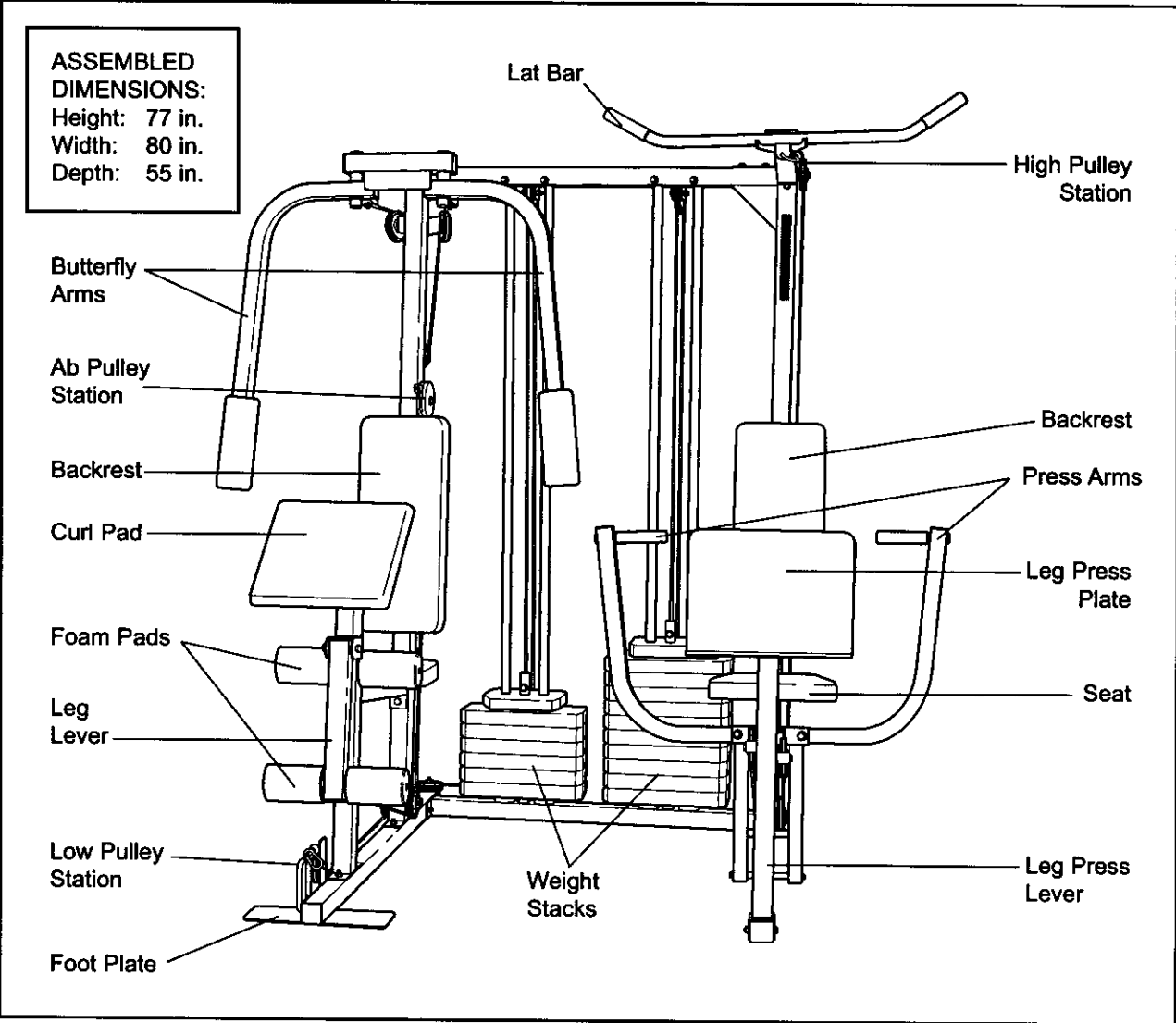

Assembly

Note: This introduction will save you more time than it takes to read it!

Making Things Easier for Yourself

Everything in this manual is designed to ensure that our products can be assembled successfully by anyone. However, it is important to realize that your new equipment is a sophisticated product with many small parts. The assembly process will take time—possibly several hours. Most people find that by setting aside plenty of time, and by deciding to make the task enjoyable, assembly will go smoothly. You may want to complete the process over a couple of evenings.

Some assembly steps require two people.

Giving Yourself a Good Start

Before you begin the assembly process itself, take the time to complete the steps outlined here.

Clearing the Workspace

Clear a workspace that is large enough to hold all parts and allow you to walk all the way around the assembled equipment.

Unpacking the Box

To make the assembly process as smooth as possible, we have broken it into separate stages. All parts used in each stage are found in individual packages in the shipping box. Place all parts in a cleared area and remove the packing materials. Do not dispose of the packing materials until assembly is completed.

Important: Wait until you begin each assembly stage to open the parts bag labeled for that assembly stage.

Identifying Parts

To help you identify the small parts used in assembly, we have included a PART IDENTIFICATION CHART located in the center of this manual. Place the chart on the floor or work table and use it to quickly identify different parts as you open the packages for each step. Note Some small parts may have been pre-attached for shipping. If a part is not in the parts bag, check to see if it has been pre-attached.

Orienting Parts



As you assemble this product, be sure that all parts are oriented as shown in the drawings.

Tightening Parts

Tighten all parts as you assemble them, unless instructed to do otherwise.

Lining Up the Tools

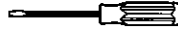
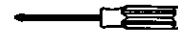
Assembly requires the following tools (not included):

- Two (2) adjustable wrenches 
- One (1) standard screwdriver 
- One (1) phillips screwdriver 
- One (1) rubber mallet 
- Lubricant, such as grease or petroleum jelly, and soapy water
- Tape, such as clear tape or masking tape

Assembly will be more convenient if you have a socket set, a set of open-end or closed-end wrenches or a set of ratchet wrenches.

The Four Stages of the Assembly Process

Frame Assembly

You will begin by assembling the base and the upright frames that serve as the skeleton of the equipment.

Arm Assembly

This assembly completes the press and butterfly arms that you operate while you are exercising.

Cable Assembly

This assembly completes the cables and pulleys that connect the moving arms with each other and with the weights.

Seat Assembly

This assembly completes the seat and backrest that support your body while you are exercising.

Frame Assembly

1. Before beginning, make sure that you have read and understood the information on page 4.

Locate and open the parts bag labeled "FRAME ASSEMBLY."

See drawing 1a. Press a 2" Square Inner Cap (28) into each end of the Butterfly Base (4). Press two 2" Square Inner Caps (28) into the Weight Base (5).

Insert four 5/16" x 2 1/2" Carriage Bolts (92) up through the indicated holes in the Butterfly Base (4). Insert a 3/8" x 3 1/2" Carriage Bolt (95) up through the hole at the end of the Butterfly Base. **Note: If the Bolts fall out, secure them by putting a small piece of tape over the head of each Bolt.** Place the Butterfly Base flat on the floor.

See drawing 1b. Attach the Weight Base (5) to the Butterfly Base (4) with two 5/16" x 2 3/4" Bolts (89), a Support Plate with 3 1/2" center holes (93), and two 5/16" Nylon Locknuts (64). **Do not tighten the Nylon Locknuts yet.**

Note: There are three kinds of Support Plates. The main difference between them is the distance between the holes. When you need a Support Plate, find the type with holes that will fit over the Bolts you are using.

2. See drawing 2a. Press a 2" Square Inner Cap (28) into the end of the Press Base (6).

Attach a 3 1/2" Pulley (24) to each of the brackets on the Weight Base (5) with a 3/8" x 1 3/4" Bolt (57) and a 3/8" Nylon Jamnut (63).

Insert four 5/16" x 2 1/2" Carriage Bolts (92) up through the indicated holes in the Press Base (6). Insert a 3/8" x 2 1/2" Carriage Bolt (101) and a 3/8" x 4" Carriage Bolt (102) up through the indicated holes at the end of the Press Base (6).

See drawing 2b. Attach the Press Base (6) to the Weight Base (5) with two 5/16" x 2 3/4" Bolts (89), a Support Plate with 3 1/2" center holes (93), and two 5/16" Nylon Locknuts (64). **Do not tighten the Nylon Locknuts yet.**

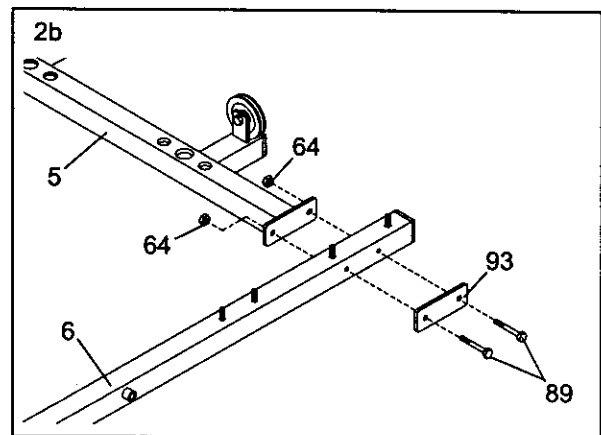
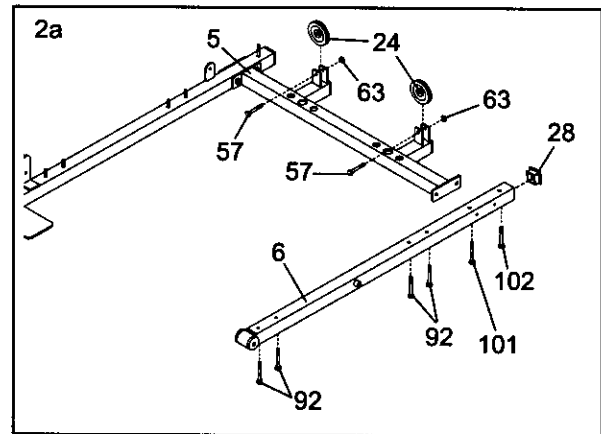
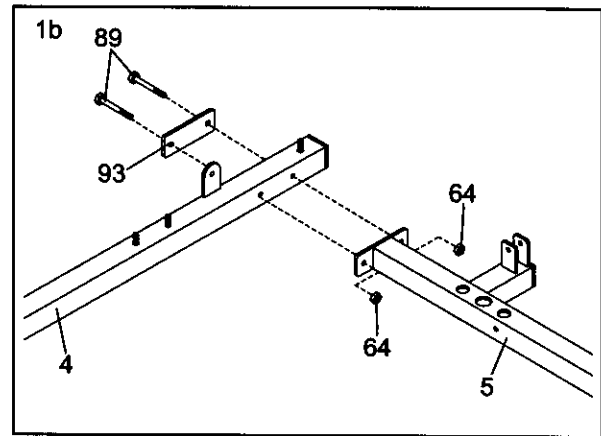
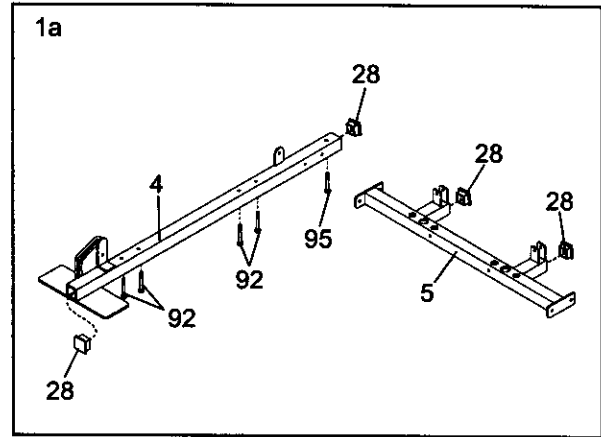

- Place the bracket on the lower end of the Butterfly Upright (1) over the indicated 5/16" x 2 1/2" Carriage Bolts (92) in the Butterfly Base (4). Hand tighten two 5/16" Nylon Locknuts (64) onto the Bolts. **Do not tighten the Nylon Locknuts yet.**

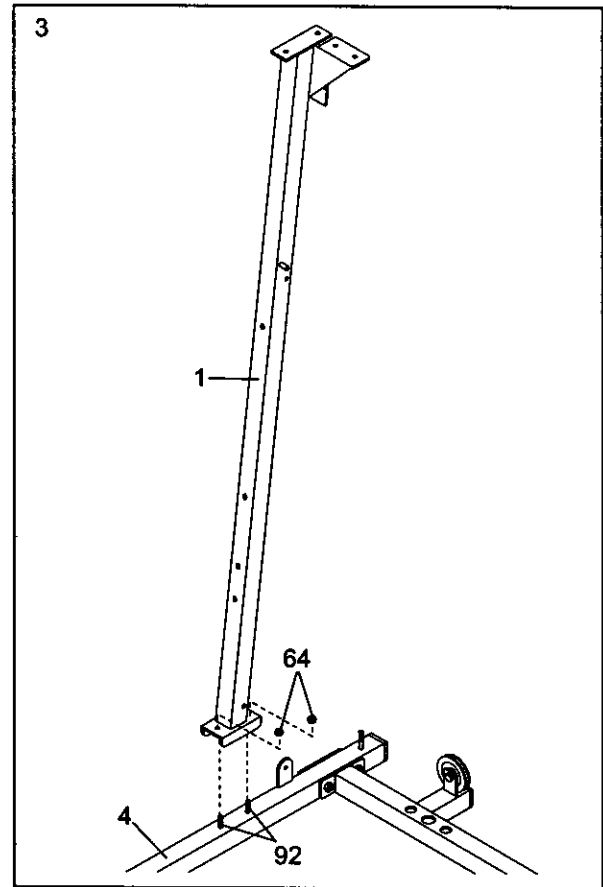

- Press three 2" Square Inner Caps (28) into the Butterfly Top Frame (33). Press two 1" Round Inner Cap (86) into the top of the Butterfly Top Frame (33).

Attach the Butterfly Top Frame (33) to the indicated bracket at the top of the Butterfly Upright (1) with two 5/16" x 2 3/4" Bolts (89), a Support Plate with 3 1/2" center holes (93), and two 5/16" Nylon Locknuts (64).

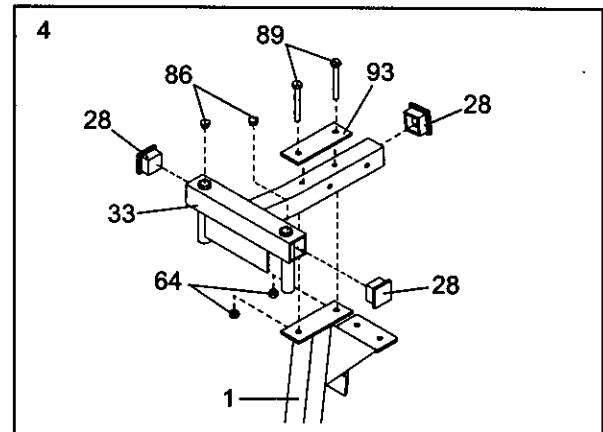

- Attach the Butterfly Seat Frame (14) to the Front Leg (20) with two 5/16" x 2 3/4" Bolts (89), two 5/16" Washers (36), and two 5/16" Nylon Locknuts (64). **Do not tighten the Nylon Locknuts yet.**

Slide the bracket on the Front Leg (20) onto the two 5/16" x 2 1/2" Carriage Bolts (92) in the Butterfly Base (4). Hand tighten two 5/16" Nylon Locknuts (64) onto the Bolts. **Do not tighten the Nylon Locknuts yet.**

Attach the Butterfly Seat Frame (14) to the Butterfly Upright (1) with two 5/16" x 2 3/4" Bolts (89), two 5/16" Washers (36) and two 5/16" Nylon Locknuts (64). **Do not tighten the Nylon Locknuts yet.**

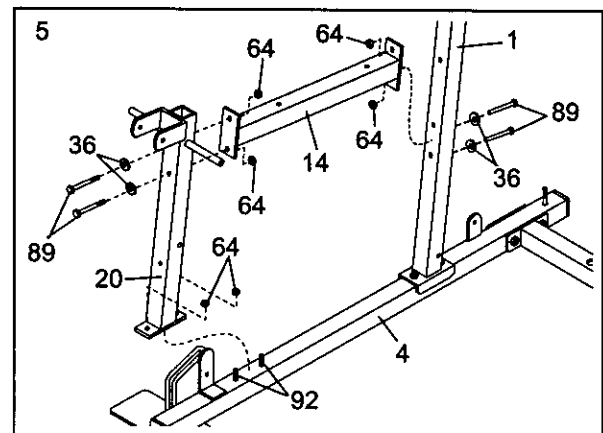

6. Press a 2" Square Inner Cap (28) half way into the top of the Front Leg (20). Press a 2" Square Inner Cap (28) into each end of the Small Leg Lever (41).

Attach the Bumper (40) to the indicated hole in the Front Leg (20) with a 1" Tap Screw (80).

Lubricate the 3/8" x 3 1/4" Bolt (62). Attach the Small Leg Lever (41) to the bracket on the Front Leg (20) with the Bolt and a 3/8" Nylon Jamnut (63). **Do not overtighten the Nylon Jamnut; it must be easy to pivot the Leg Lever.**

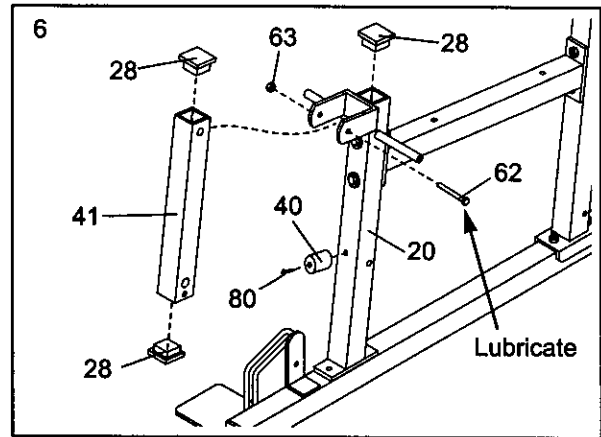

7. Press a 1" Square Inner Cap (98) into the small tube on the Press Upright (2).

Place the bracket on the lower end of the Press Upright (2) over the indicated 5/16" x 2 1/2" Carriage Bolts (92) in the Press Base (6). Hand tighten two 5/16" Nylon Locknuts (64) onto the Bolts. **Do not tighten the Nylon Locknuts yet.**

Place the bracket on the lower end of the Support Frame (3) over the indicated 3/8" x 2 1/2" Carriage Bolt (101) and the 3/8" x 4" Carriage Bolt (102) in the Press Base (6). Hand tighten a 3/8" Nylon Jamnut (63) onto the 3/8" x 2 1/2" Carriage Bolt (101). **Do not tighten the Nylon Jamnut yet.**

Note: Do not thread a Jamnut onto the 3/8" x 4" Carriage Bolt (102) yet.

Attach the Support Frame (3) to the Press Upright (2) with two 5/16" x 2 1/2" Carriage Bolts (92) and two 5/16" Nylon Locknuts (64). **Do not tighten the Nylon Locknuts yet.**

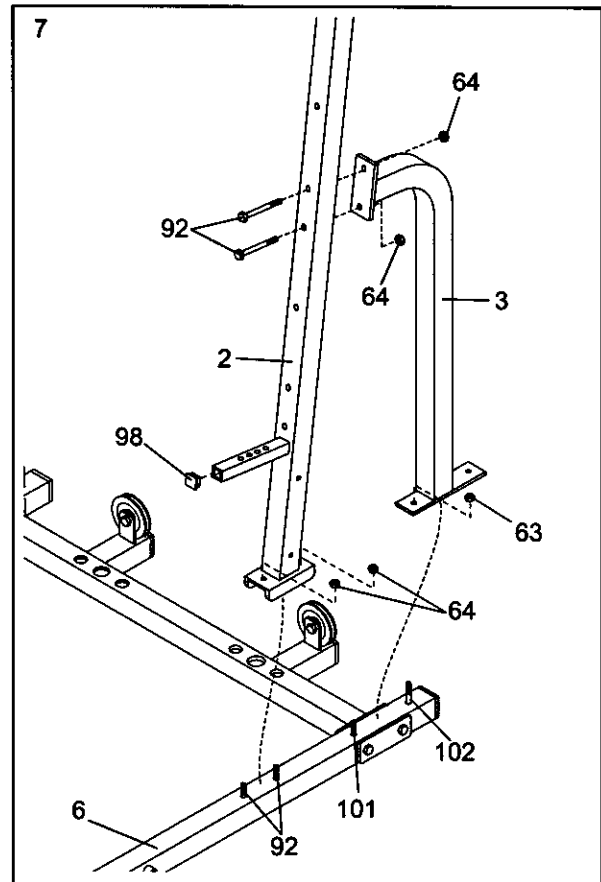

8. Press a 2" Square Inner Cap (28) into the Press Top Frame (9).

Attach the Press Top Frame (9) to the indicated bracket at the top of the Press Upright (2) with two 5/16" x 2 3/4" Bolts (89), a Support Plate with 3 1/2" center holes (93), and two 5/16" Nylon Locknuts (64).

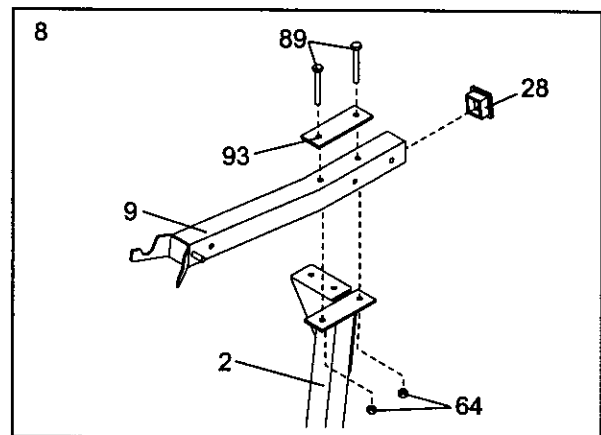

9. Press a 2" Square Inner Cap (28) into the Press Seat Frame (7).

Slide the bracket on the Press Seat Frame (7) onto the indicated 5/16" x 2 1/2" Carriage Bolts (92) in the Press Base (6). Hand tighten two 5/16" Nylon Locknuts (64) onto the Bolts. **Do not tighten the Nylon Locknuts yet.**

Attach the Press Seat Frame (7) to the Press Upright (2) with two 5/16" x 2 3/4" Bolts (89), two 5/16" Washers (36), and two 5/16" Nylon Locknuts (64). **Do not tighten the Nylon Locknuts yet.**

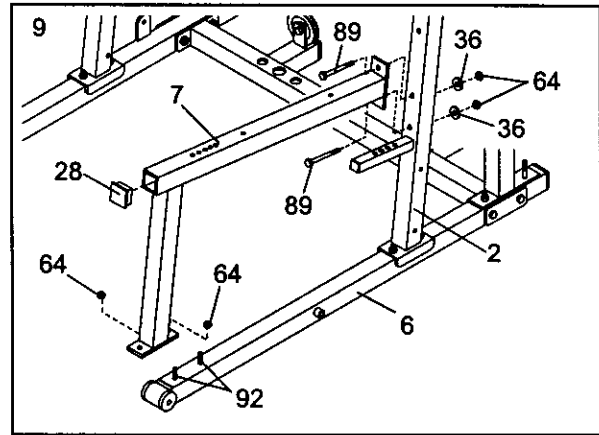

10. Lubricate the 3/8" x 3" Bolt (88). Attach the Leg Press Lever (83) to the Press Base (6) with the Bolt and a 3/8" Nylon Locknut (50). **Do not overtighten the Nylon Locknut; the Leg Press Lever must pivot easily.**

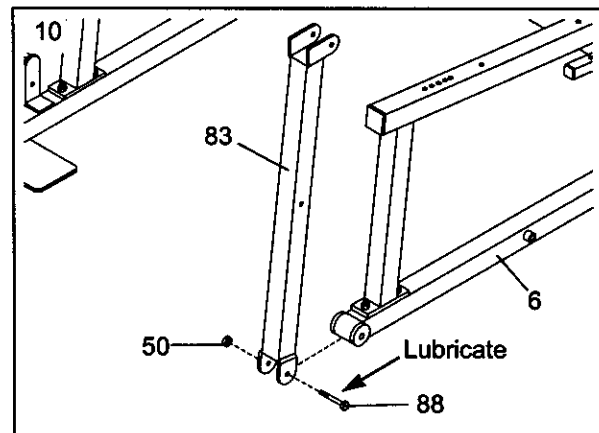

11. Place two Weight Bumpers (51) over the indicated holes in the Weight Base (5). Slide a Weight Guide (15) into each of the holes.

Attach the indicated Weight Guide (15) to the Weight Base (5) with a 3/8" x 2 3/4" Bolt (46), two 3/8" Flat Washers (48), and a 3/8" Nylon Locknut (50).

Slide six Weights (21) onto the Weight Guides (15). **Make sure the Weights are turned so the pin grooves point towards the floor.**

Press a Weight Tube Bumper (18) into the lower end of the Short Weight Tube (17). Slide the Weight Tube into the center holes in the Weights (21).

Slide a Top Weight (16) onto the Weight Guides (15). **Note: Make sure the Top Weight is turned so the groove fits over the welded pin on the Weight Tube (17).**

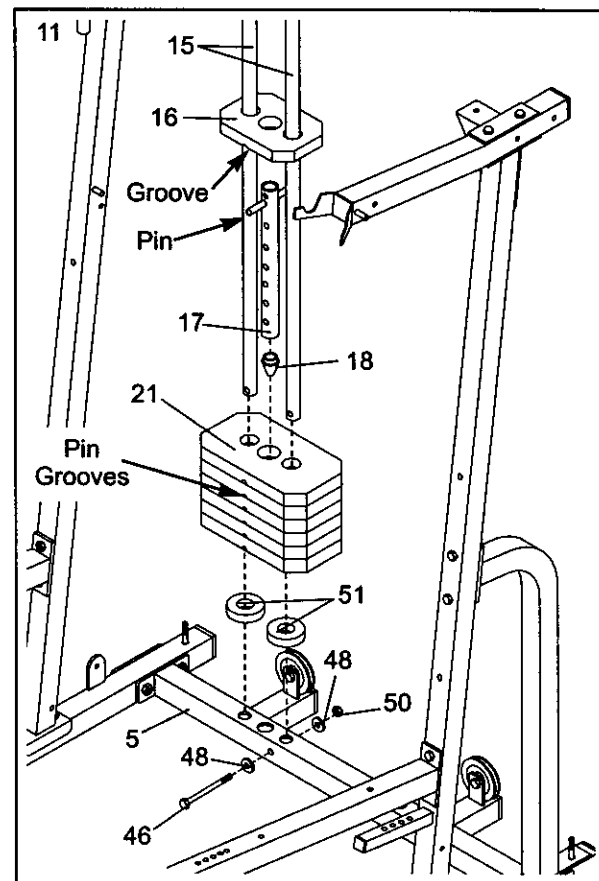

12. Place two Weight Bumpers (51) over the indicated holes in the Weight Base (5). Slide a Weight Guide (15) into each of the holes.

Attach the indicated Weight Guide (15) to the Weight Base (5) with a 3/8" x 2 3/4" Bolt (46), two 3/8" Flat Washers (48), and a 3/8" Nylon Locknut (50).

Slide ten Weights (21) onto the Weight Guides (15). **Make sure the Weights are turned so the pin grooves point towards the floor.**

Press a Weight Tube Bumper (18) into the lower end of the Long Weight Tube (70). Slide the Weight Tube into the center holes in the Weights (21).

Slide a Top Weight (16) onto the Weight Guides (15). **Note: Make sure the Top Weight is turned so the groove fits over the welded pin on the Weight Tube (70).**

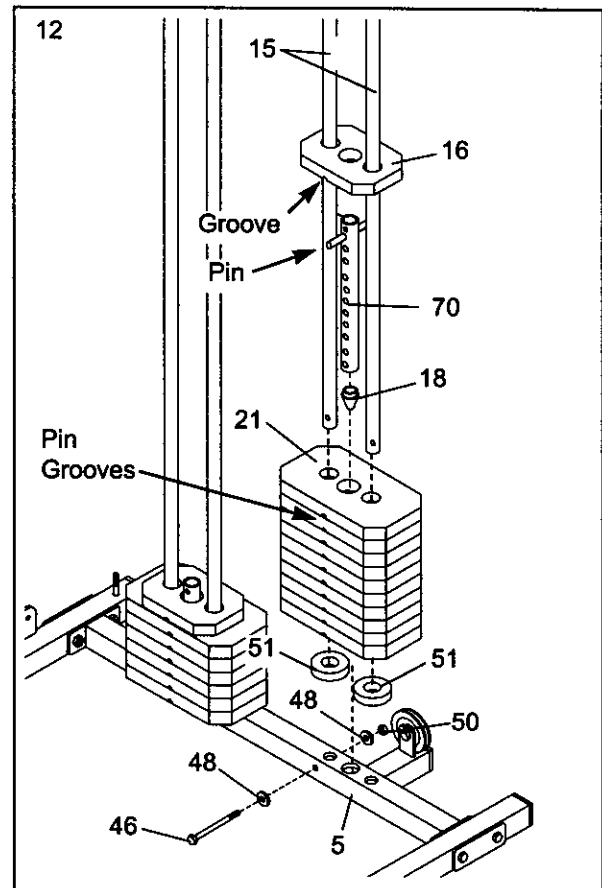

13. Place the Weight Top Frame (66) on the indicated brackets on the Uprights (1 and 2). **Note: The four Weight Guides (15) must be behind the Weight Top Frame, as shown in step 14.**

Attach the Weight Top Frame (66) to the Butterfly Top Frame (33) with two 3/8" x 2 3/4" Bolts (46), a Support Plate with 4" center holes (94), and two 3/8" Nylon Locknuts (50). **Do not tighten the Nylon Locknuts yet.**

Attach the Weight Top Frame (66) to the bracket on the Butterfly Upright (1) with two 3/8" x 2 3/4" Bolts (46), a Support Plate with 2 1/2" center holes (34), and two 3/8" Nylon Locknuts (50). **Do not tighten the Nylon Locknuts yet.**

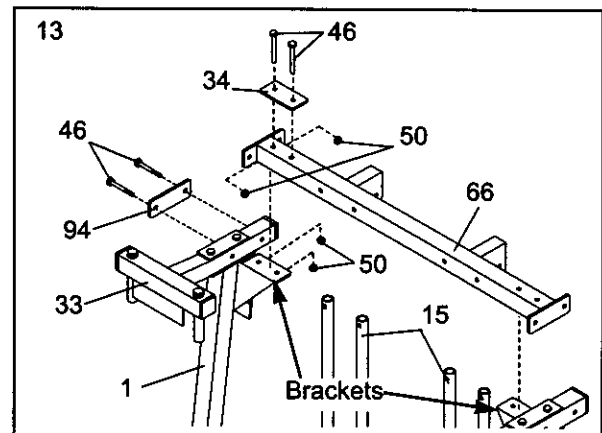

14. Attach the Weight Top Frame (66) to the Press Top Frame (9) with one 3/8" x 2 3/4" Bolt (46), a Support Plate with 4" center holes (94), and a 3/8" Nylon Locknut (50). Slide a 3 1/2" Pulley (24) with a Cable Trap (25) onto a 3/8" x 4" Bolt (78). Insert the Bolt through the Support Plate (94) and hand tighten a 3/8" Nylon Locknut (50) onto it.

Attach the Weight Top Frame (66) to the bracket on the Press Upright (2) with two 3/8" x 2 3/4" Bolts (46), a Support Plate with 2 1/2" center holes (34) and two 3/8" Nylon Locknuts (50). **Do not tighten the Nylon Locknuts yet.**

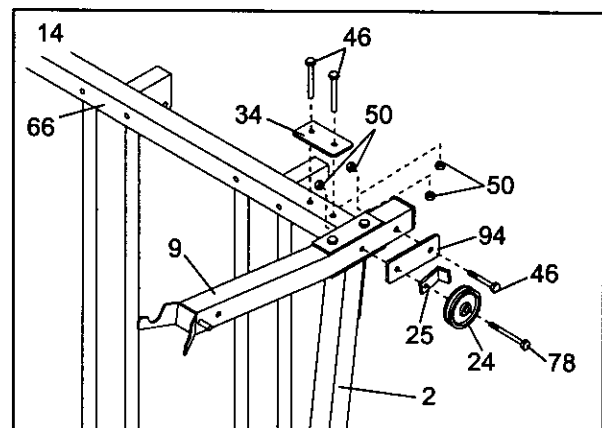

- Attach each of the four Weight Guides (15) to the Weight Top Frame (66) with a $3/8" \times 3 3/4"$ Bolt (59), a $3/8"$ Flat Washer (48), and a $3/8"$ Nylon Locknut (50).

Important: Go back and fully tighten all Nylon Locknuts used in steps 1 through 15.

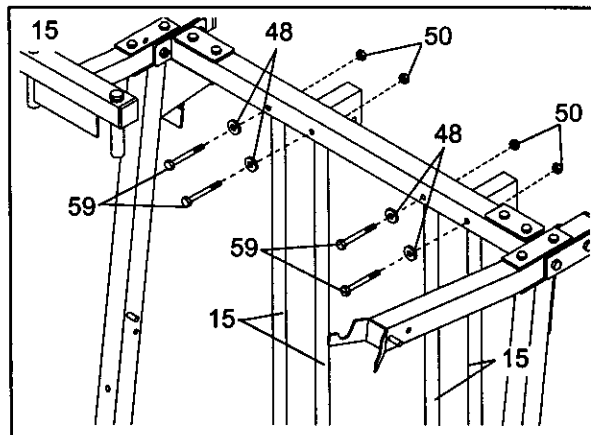

Arm Assembly

- Locate and open the parts bag labeled "ARM ASSEMBLY."

Press a Plastic Bushing (100) onto each welded tube on the Press Frame (8).

Lubricate the $3/8" \times 8"$ Bolt (52). Attach the Press Frame (8) to the welded tubes on the Press Base (6) with the Bolt and a $3/8"$ Nylon Locknut (50). **Do not overtighten the Nylon Locknut; it must be easy to pivot the Press Frame.**

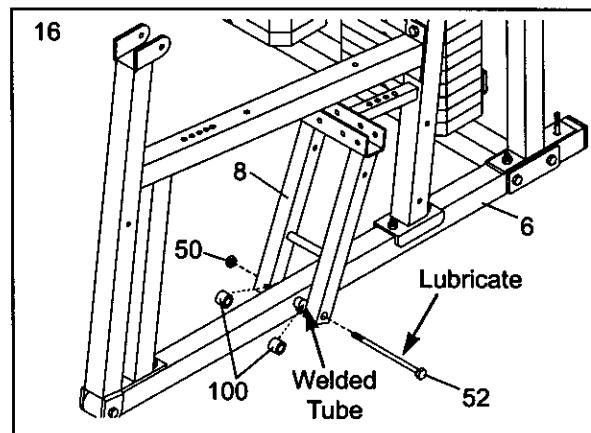

- Press a $1 3/4"$ Square Inner Cap (35) into the top of a Press Arm (77). Press a $1"$ Round Inner Cap (76) into the indicated hole in the Press Arm.

Attach the Press Arm (77) to the bracket on the Press Frame (8) with two $5/16" \times 2 1/2"$ Bolts (87) and two $5/16"$ Nylon Locknuts (64).

Repeat this step to assemble the second Press Arm (77, not shown).

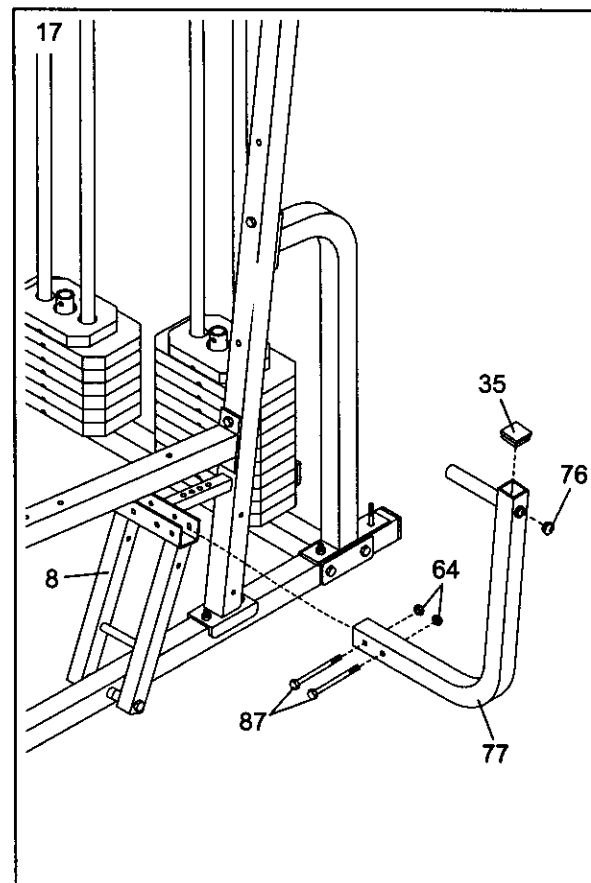

18. Press a 1 3/4" Square Inner Cap (35) into each end of the Right Butterfly Arm (11). Wet the lower end of the Arm with soapy water. Slide a Butterfly Foam Pad (29) onto the lower end of the Arm.

Lubricate the indicated axle on the Butterfly Top Frame (33). Orient the Right Butterfly Arm (11) as shown and slide it onto the axle. Secure the Butterfly Arm with two Retainer Rings (31) and a 1" Round Outer Cap (38). **Note: Place the Retainer Rings on top of the inverted Outer Cap and gently tap the Cap onto the axle with a hammer. Make sure the teeth on the Retainer Rings bend towards the Cap as shown in the inset drawing.**

Repeat this step to assemble the Left Butterfly Arm (10, not shown).

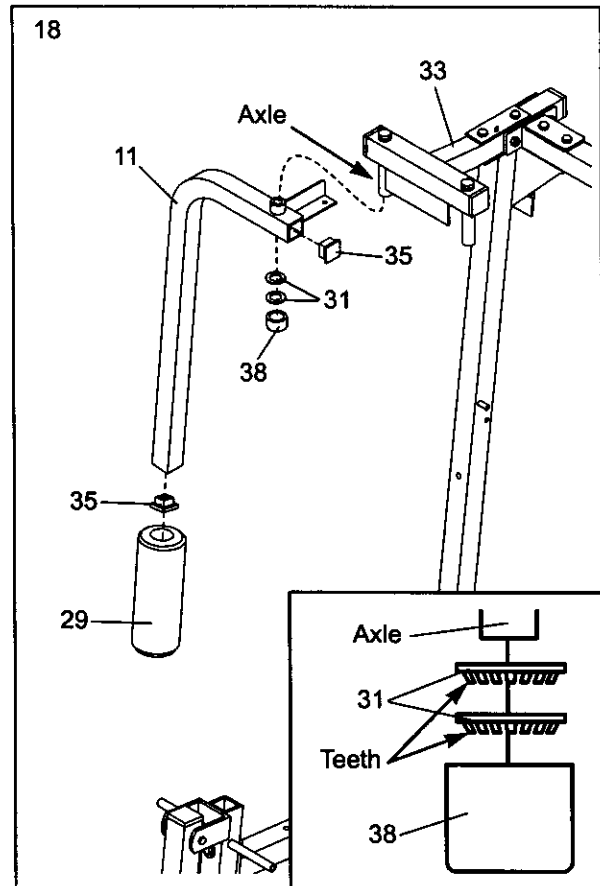

Cable Assembly

19. Locate and open the parts bag labeled "CABLE ASSEMBLY." For Cable identification and routing during steps 19 to 49, refer to the Cable Diagrams and Cable ID Chart on pages 23 and 24.

Identify the Butterfly Cable (73). It is approximately 52" long and it has a closed loop on each end. Attach the Butterfly Cable to the bracket on the Left Butterfly Arm (10) with a 3/8" x 1" Bolt (84) and two 3/8" Nylon Jamnuts (63). **Note: The loop on the Cable and the two Nylon Jamnuts must be mounted underneath the welded bracket.**

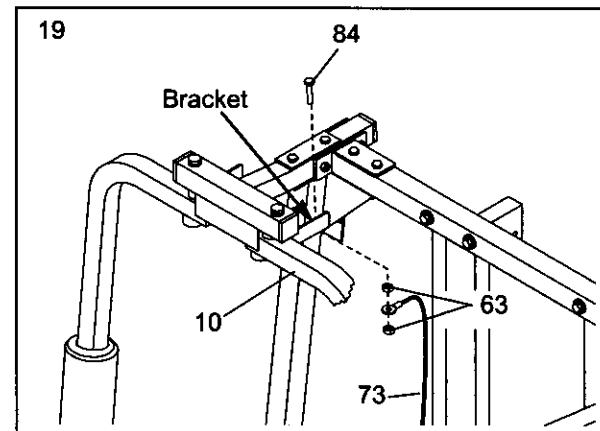

20. Locate and open the parts bag labeled "PULLEY BAG 2." Remove one "V"-Pulley (27) from the bag. Leave the remaining pulleys in the bag for identification of the Pro Pulley.

Wrap the Butterfly Cable (73) around a "V"-Pulley (27) in the direction shown. Attach the "V"-Pulley and a Large Cable Trap (32) to the bracket on the back of the Butterfly Upright (1) with a 3/8" x 2 1/2" Bolt (53) and a 3/8" Nylon Locknut (50). **Make sure the Large Cable Trap is oriented as shown.**

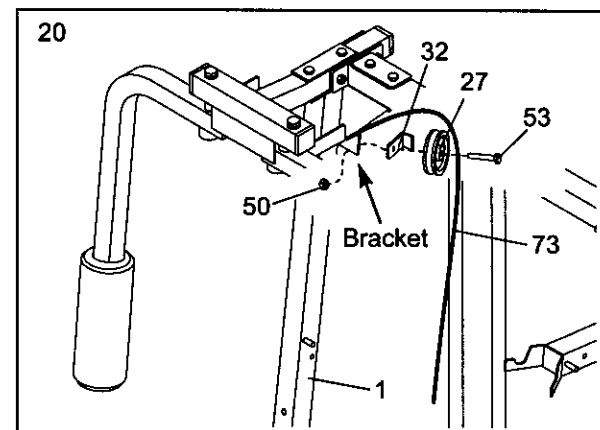

21. Remove both 3 1/2" Pulleys (24) from the pre-assembled Small Pulley Bracket (22).

Wrap the Butterfly Cable (73) around a 3 1/2" Pulley (24) in the direction shown. Attach the Pulley to the Small Pulley Bracket (22) with a 3/8" x 1 3/4" Bolt (57) and a 3/8" Nylon Locknut (50). **Make sure the Small Pulley Bracket is oriented exactly as shown.**

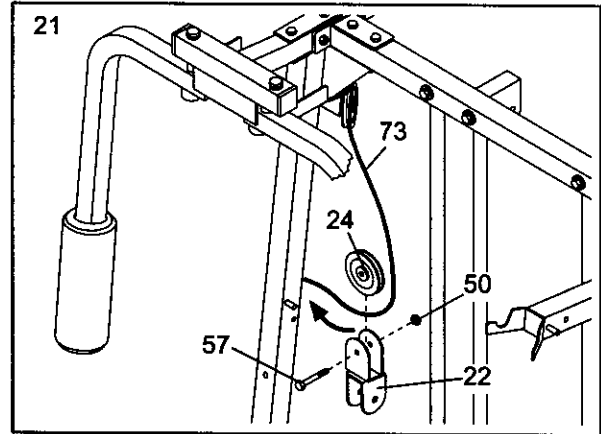

22. Wrap the Butterfly Cable (73) around a "V"-Pulley (27) in the direction shown. Attach the "V"-Pulley and a Large Cable Trap (32) to the bracket on the back of the Butterfly Upright (1) with a 3/8" x 2 1/2" Bolt (53) and a 3/8" Nylon Locknut (50). **Make sure the Large Cable Trap is oriented as shown.**

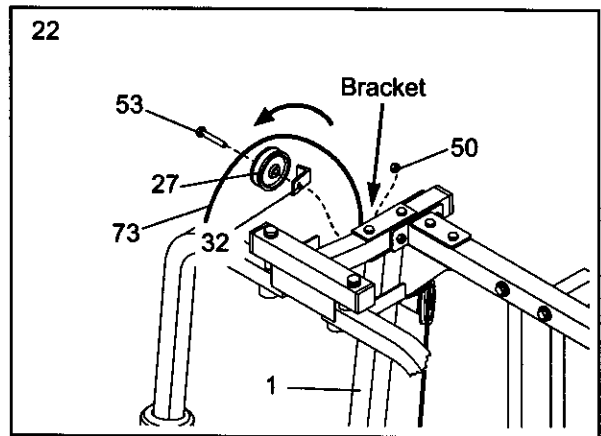

23. Attach the Butterfly Cable (73) to the bracket on the Right Butterfly Arm (11) with a 3/8" x 1" Bolt (84) and two 3/8" Nylon Jamnuts (63). **Note: The loop on the Cable and the two Nylon Jamnuts must be mounted underneath the welded bracket.**

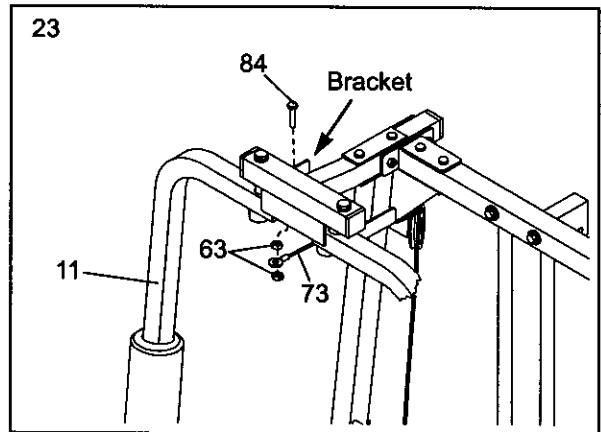

24. Identify the Ab Cable (74). It is approximately 224" long, and it has a ball on one end and a threaded shaft on the other. You will start by attaching the end of the Cable with the ball.

Wrap the Ab Cable (74) around a 3 1/2" Pulley (24) in the direction shown. Place two Pulley Covers (47) over the Pulley, so that the slots in the Pulley Covers are placed over the Cable. Attach the Pulley and Pulley Covers to the indicated hole in the Butterfly Upright (1) with a 3/8" x 3 3/4" Bolt (59), two 3/8" Flat Washers (48), and a 3/8" Nylon Jamnut (63). **Make sure the Cable is between the Pulley and the welded pin on the Upright.**

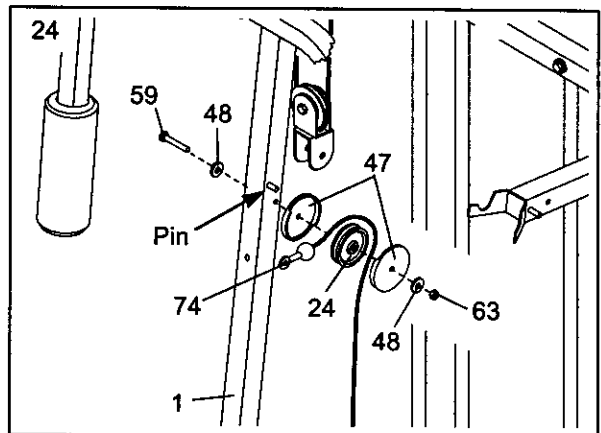

25. Remove both 3 1/2" Pulleys (24) from the pre-assembled Adjustable Pulley Plates (23).

Wrap the Ab Cable (74) around a 3 1/2" Pulley (24) in the direction shown. Attach the Pulley and a Cable Trap (25) to the top hole in the two Adjustable Pulley Plates (23) with a 3/8" x 2" Bolt (54) and a 3/8" Nylon Locknut (50). **Make sure the Cable Trap and the Pulley Plates are oriented as shown.**

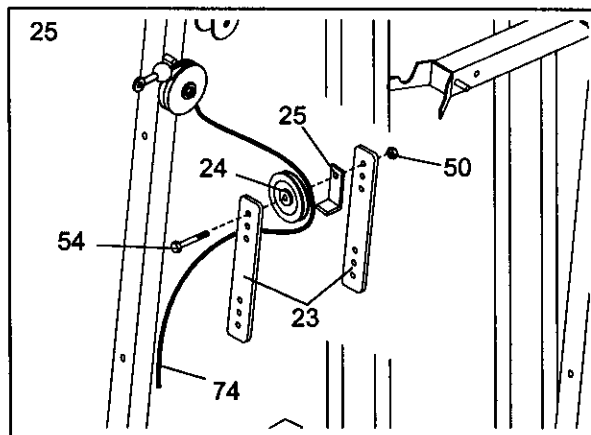

26. Wrap the Ab Cable (74) around a 3 1/2" Pulley (24) in the direction shown. Attach the Pulley to the Small Pulley Bracket (22) with a 3/8" x 1 3/4" Bolt (57) and a 3/8" Nylon Locknut (50). **Make sure the Pulley Bracket is oriented as shown.**

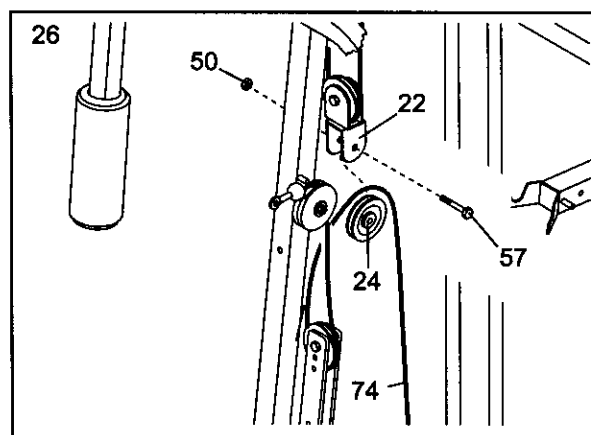

27. Wrap the Ab Cable (74) around a 3 1/2" Pulley (24) in the direction shown. Attach the Pulley and a Cable Trap (25) to the welded bracket on the Butterfly Base (4) with a 3/8" x 2" Bolt (54) and a 3/8" Nylon Locknut (50). **Make sure the Cable Trap is oriented as shown.**

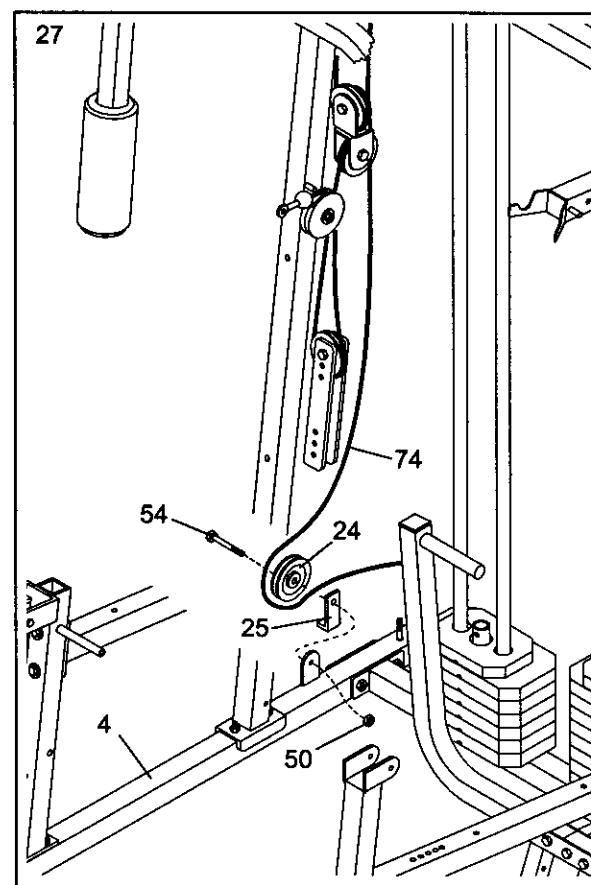

28. Wrap the Ab Cable (74) around a 3 1/2" Pulley (24) in the direction shown. Slide the Pulley and a Cable Trap (25) onto the 3/8" x 3 1/2" Carriage Bolt (95) already inserted into the Butterfly Base (4). Secure the Pulley with a 3/8" Nylon Jamnut (63). **Make sure the Cable Trap is oriented as shown.**

Route the threaded end of the Ab Cable (74) under the 3 1/2" Pulley (24) that is already mounted on the Weight Base (5). **Make sure the Cable is routed in the direction shown.**

Note: For clarity, this and the following drawings show some parts removed.

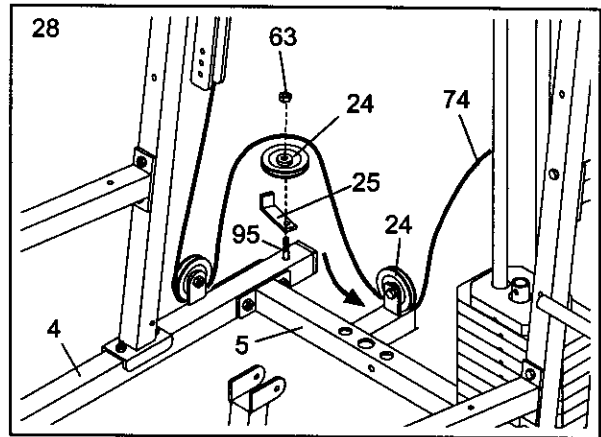

29. Wrap the Ab Cable (74) around a 4 1/2" Pulley (82) in the direction shown. Attach the Pulley inside the indicated bracket on the Weight Top Frame (66) with a 3/8" x 1 3/4" Bolt (57) and a 3/8" Nylon Locknut (50). **Make sure the threaded end of the Ab Cable is routed through the bracket, as shown.**

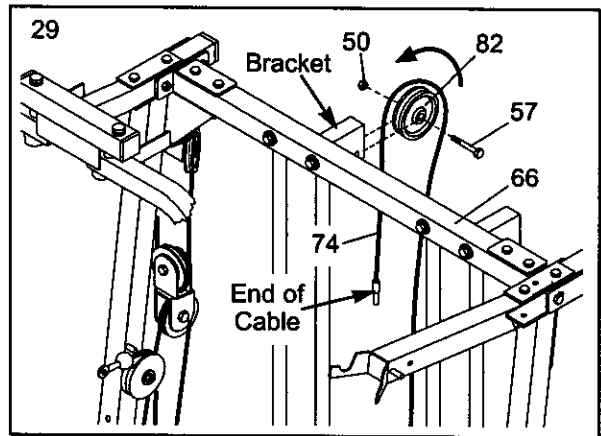

30. Attach the threaded end of the Ab Cable (74) to a "U"-Bracket (97) with a 1/4" Flat Washer (71) and a 1/4" Nylon Locknut (68).

Attach the "U"-Bracket (97) to the hole in the Short Weight Tube (17) with a 5/16" x 1 3/4" Bolt (96) and a 5/16" Nylon Locknut (64). **Note: Do not completely tighten the Nylon Locknut; it should be threaded only two turns onto the end of the Cable, as shown in the inset drawing.**

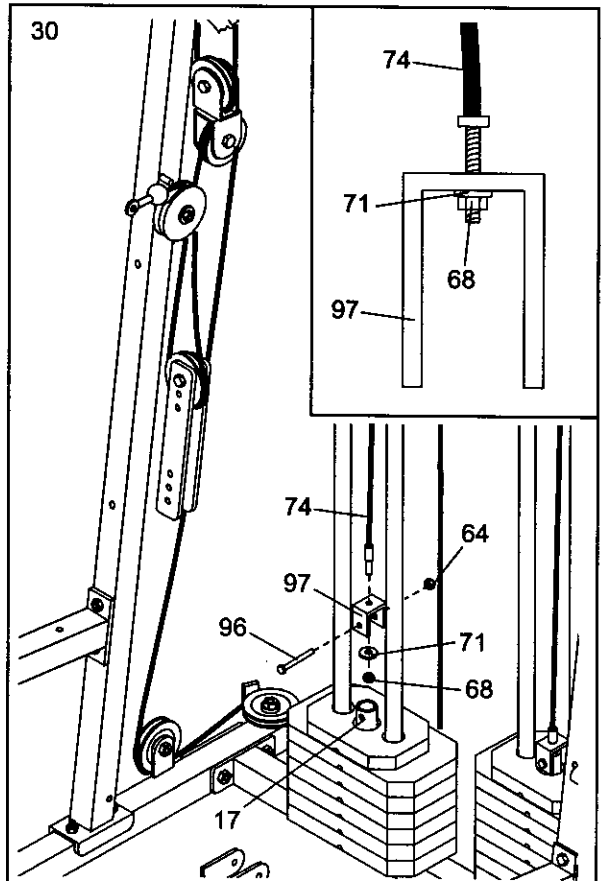

31. Remove a Pro Pulley (26) from the bag labeled "PULLEY BAG 2".

Identify the Low Pulley Cable (75). It is approximately 143 1/2" long and it has a ball on one end and a loop on the other. Route the end with the loop through the slot in the cable guide on the Butterfly Base (4).

Route the Low Pulley Cable (75) under a Pro Pulley (26) as shown. Attach the Pro Pulley and a Cable Trap (25) to the bracket on the Butterfly Base (4) with a 3/8" x 2" Bolt (54) and a 3/8" Nylon Locknut (50). **Make sure the Cable Trap is oriented as shown.**

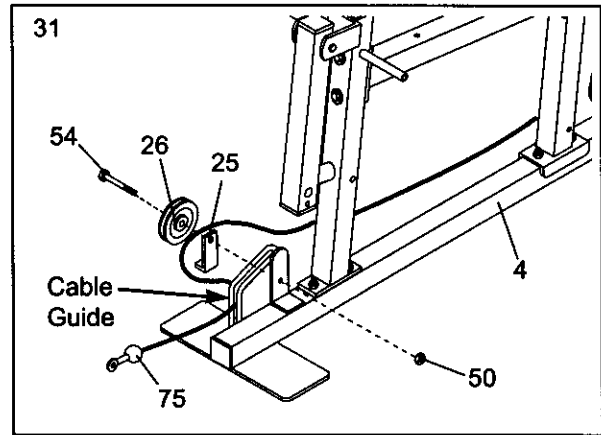

32. Wrap the Low Pulley Cable (75) around a 3 1/2" Pulley (24) in the direction shown. Attach the Pulley and a Cable Trap (25) to the indicated hole in the Butterfly Upright (1) with a 3/8" x 4 3/4" Bolt (60) and a 3/8" Nylon Jamnut (63). Note: Thread the Jamnut only two turns onto the Bolt, since you will later attach another Pulley to the Bolt. Make sure the Cable Trap is oriented as shown.

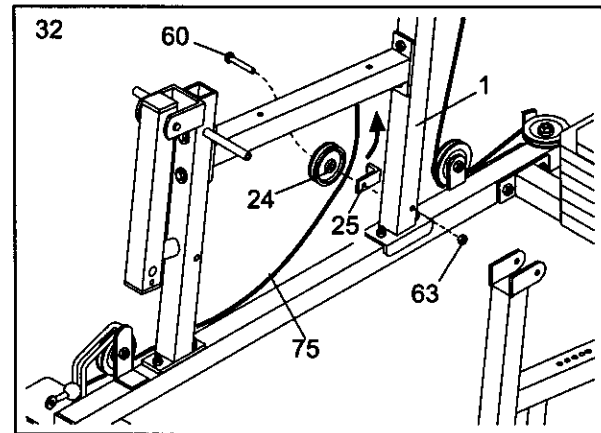

33. Wrap the Low Pulley Cable (75) over a 3 1/2" Pulley (24) in the direction shown. Attach the Pulley and a Cable Trap (25) to the lower hole in the Adjustable Pulley Plates (23) with a 3/8" x 2" Bolt (54) and a 3/8" Nylon Locknut (50). Make sure the Cable Trap is oriented as shown.

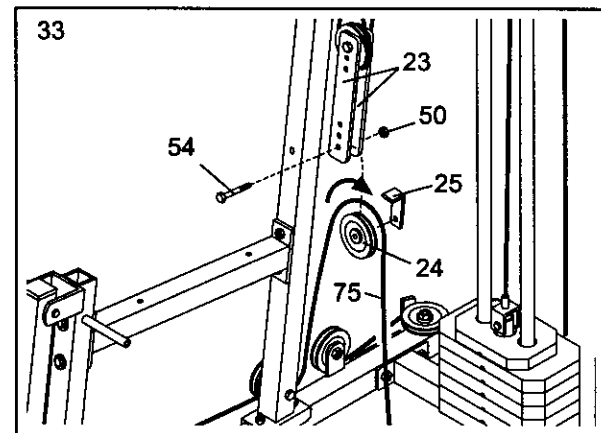

34. Remove the 3/8" Nylon Jamnut (63) from the 3/8" x 4 3/4" Bolt (60) inserted into the Butterfly Upright (1) in step 32.

Wrap the Low Pulley Cable (75) around a 3 1/2" Pulley (24) in the direction shown. Attach the Pulley and a Cable Trap (25) to the 3/8" x 4 3/4" Bolt (60) with the 3/8" Nylon Jamnut (63). **Make sure the Cable Trap is oriented as shown.**

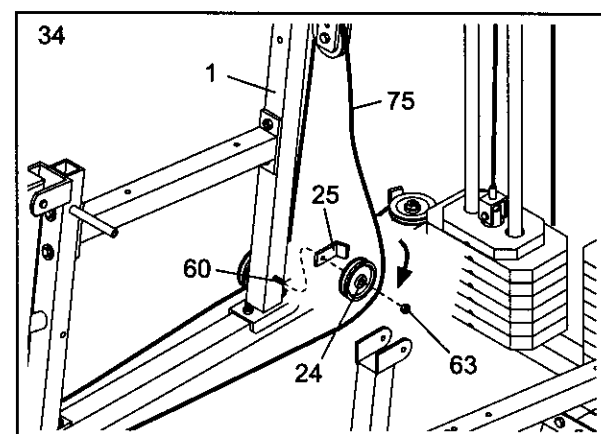

35. Attach the loop on the end of the Low Pulley Cable (75) to the indicated hole in the Small Leg Lever (41) with a $3/8"$ x $2\ 3/4"$ Bolt (46), two $3/8"$ Flat Washers (48), and a $3/8"$ Nylon Jamnut (63).

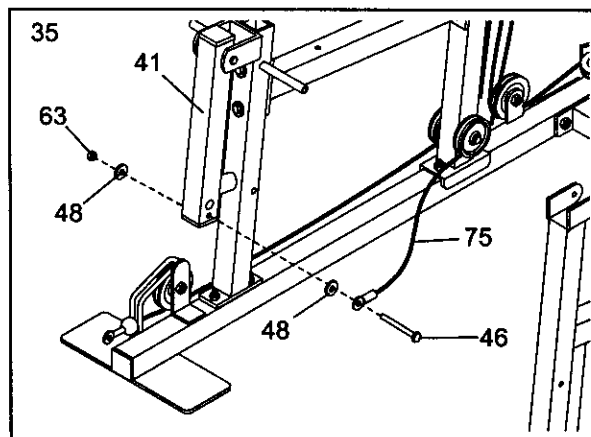

36. Remove a Pro Pulley (26) from the bag labeled "PULLEY BAG 2".

Identify the Press Cable (72). It is approximately 389 $1/2"$ long and it has a ball on one end and a threaded shaft on the other. You will begin by attaching the end with the ball.

Wrap the Press Cable (72) around a Pro Pulley (26) in the direction shown. Attach the Pulley to the indicated hole in the Press Top Frame (9) with a $3/8"$ x $3\ 1/2"$ Bolt (56), a $3/8"$ Flat Washer (48), and a $3/8"$ Nylon Jamnut (63). **Make sure the Cable is between the Pulley and the welded pin on the Press Top**

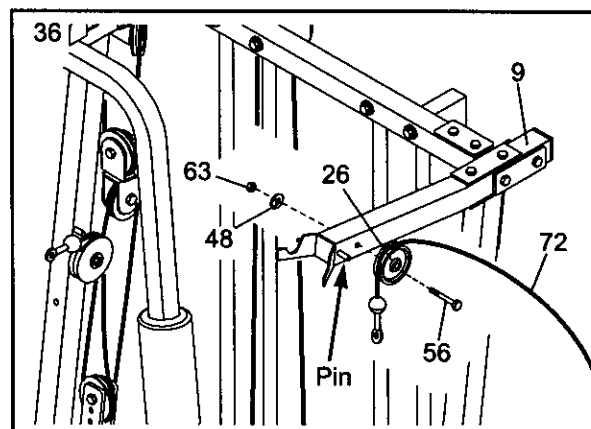

37. Route the threaded end of the Press Cable (72) around the $3\ 1/2"$ Pulley (24) that is already mounted on the Top Frame (9).

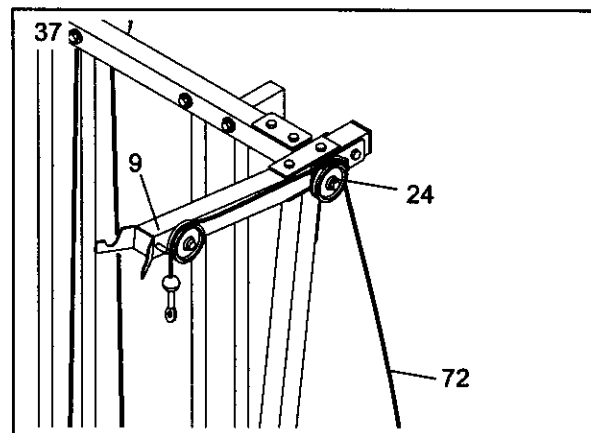

38. Wrap the Press Cable (72) around a $3\ 1/2"$ Pulley (24) in the direction shown. Attach the Pulley to the indicated hole in the Press Upright (2) with a $3/8"$ x $3\ 3/4"$ Bolt (59), a $3/8"$ Flat Washer (48) and a $3/8"$ Nylon Locknut (50). **Make sure the Cable Trap is oriented as shown.**

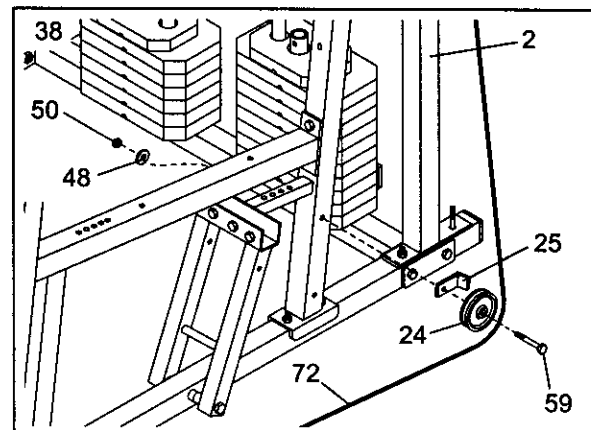

39. **Important:** Although the following steps are not difficult to perform, the correct routing of the cable is critical to the functioning of the home gym. Please make sure that you wrap the cable around the pulleys exactly as shown in each step.

Route the Press Cable (72) through the opening in the Press Frame (8), and wrap the Cable around a 3 1/2" Pulley (24) in the direction shown. Route the end of the Cable back through the opening in the Press Frame.

Attach the Pulley (24) to the indicated hole in the Press Frame (8) with a 3/8" x 3 1/4" Bolt (62), a 3/8" Flat Washer (48) and a 3/8" Nylon Locknut (50). **Make sure the Pulley is mounted on the inside of the Press Frame. Make sure the Cable Trap is oriented as shown.**

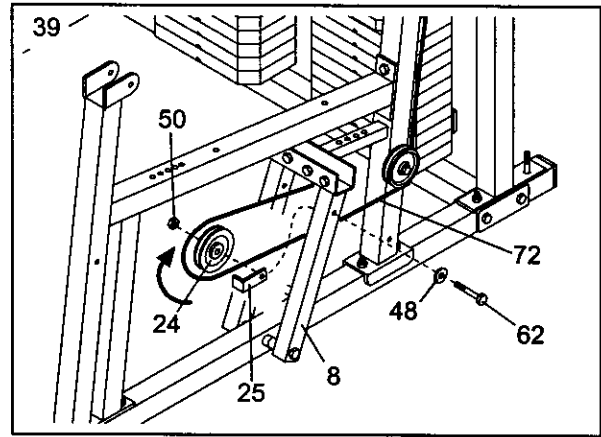

40. Wrap the Press Cable (72) around a "V"-Pulley (27) in the direction shown. Attach the "V"-Pulley and a Large Cable Trap (32) to the small tube on the Press Upright (2) with a 3/8" x 3 1/4" Bolt (62), a 3/8" Flat Washer (48) and a 3/8" Nylon Locknut (50). **Note: The small tube has four adjustment holes. Mount the "V"-Pulley in the hole farthest from the Upright. Make sure the Cable Trap is oriented as shown.**

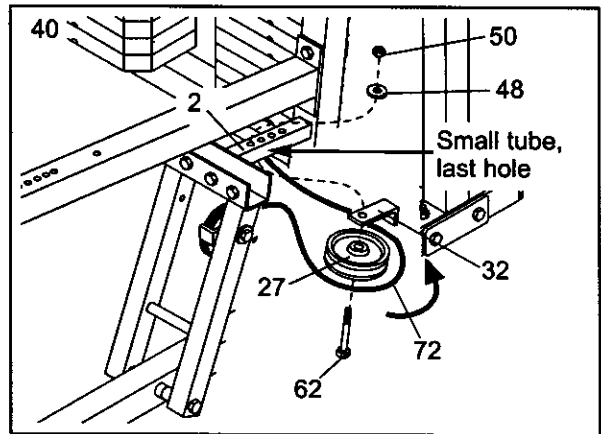

41. Route the Press Cable (72) back through the opening in the Press Frame (8) and wrap the Press Cable around a 3 1/2" Pulley (24) in the direction shown. Then, route the Press Cable back through the opening in the Press Frame (8).

Attach the Pulley (24) to the indicated hole in the Press Frame (8) with a 3/8" x 3 1/4" Bolt (62), a 3/8" Flat Washer (48), and a 3/8" Nylon Locknut (50). **Make sure the Pulley is mounted on the inside of the Press Frame. Make sure the Cable Trap is oriented as shown.**

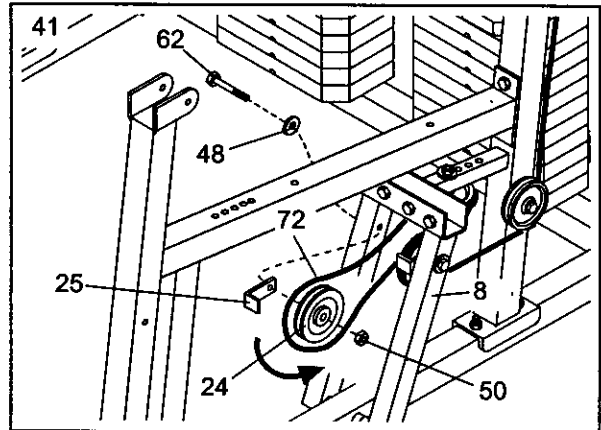

42. Wrap the Press Cable (72) around a 3 1/2" Pulley (24) in the direction shown. Attach the Pulley and a Cable Trap (25) to the indicated hole on the far side of the Press Upright (2) with a 3/8" x 4 3/4" Bolt (60) and a 3/8" Nylon Jamnut (63). **Note: Thread the Jamnut only two turns onto the Bolt; you will later attach another Pulley to the Bolt. Make sure the Cable Trap is oriented as shown.**

Route the Press Cable (72) back through the opening in the Press Frame (8), so the end is in front of the Press Frame.

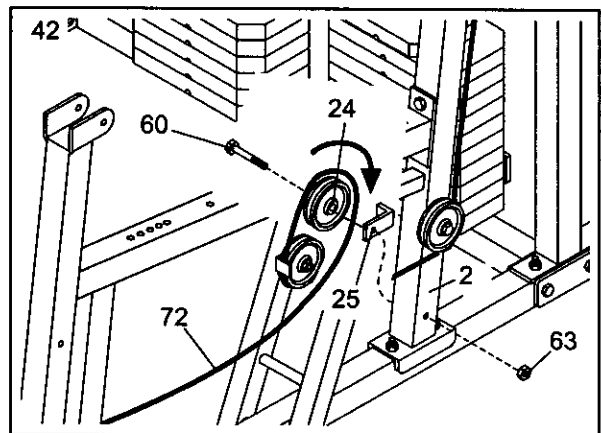

43. Wrap the Press Cable (72) around a 3 1/2" Pulley (24) in the direction shown. Attach the Pulley and a Cable Trap (25) to the indicated hole on the far side of the Leg Press Lever (83) with a 3/8" x 4 3/4" Bolt (60) and a 3/8" Nylon Jamnut (63). **Note: Thread the Jamnut only two turns onto the Bolt; you will later attach another Pulley to the Bolt. Make sure the Cable Trap is oriented as shown.**

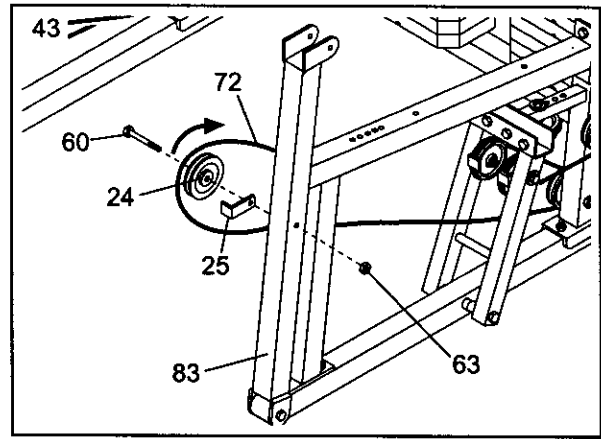

44. Wrap the Press Cable (72) around a "V"-Pulley (27) in the direction shown. Attach the "V"-Pulley and a Large Cable Trap (32) underneath the Press Seat Frame (7) with a 3/8" x 4 1/4" Bolt (85), a 3/8" Flat Washer (48), and a 3/8" Nylon Locknut (50). **Note: the Press Seat Frame has five adjustment holes. Mount the "V"-Pulley in the hole closest to the Leg Press Lever. Make sure the Cable Trap is oriented as shown.**

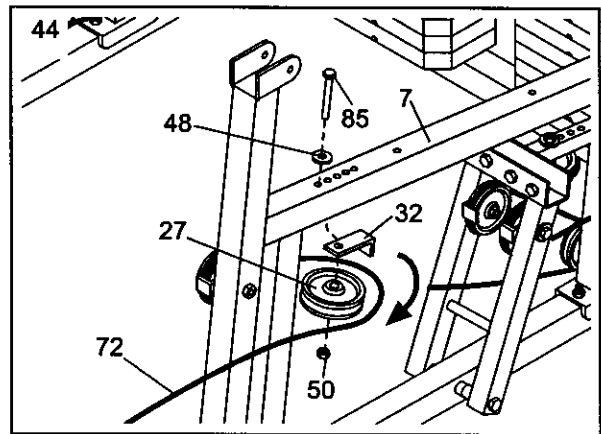

45. Wrap the Press Cable (72) around a 3 1/2" Pulley (24) in the direction shown. Attach the Pulley and a Cable Trap (25) to the near side of the Leg Press Lever (83). Use the 3/8" x 4 3/4" Bolt (60) that was inserted in step 43 and secure the Pulley with the 3/8" Nylon Jamnut (63). **Make sure the Cable Trap is oriented as shown.**

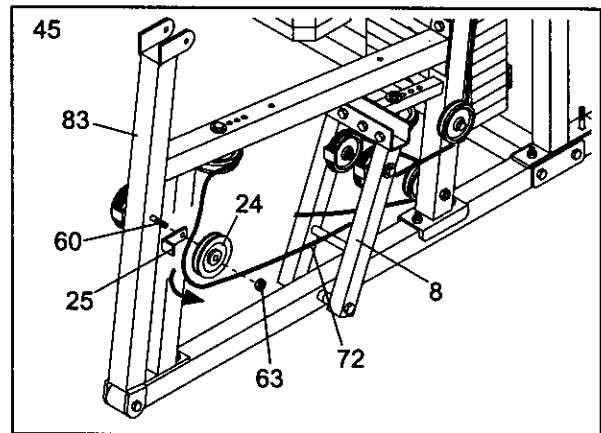

46. Wrap the Press Cable (72) around a 3 1/2" Pulley (24) in the direction shown. Attach the Pulley and a Cable Trap (25) to near side of the Press Upright (2). Use the 3/8" x 4 3/4" Bolt (60) that was inserted in step 42 and secure the Pulley with the 3/8" Nylon Jamnut (63). **Make sure the Cable Trap is oriented as shown.**

Wrap the Press Cable (72) around a 3 1/2" Pulley (24) in the direction shown. Attach the Pulley and a Cable Trap (25) to the 3/8" x 4" Carriage Bolt (102) that was inserted into the Press Base (6) earlier. Secure the Pulley with the 3/8" Nylon Locknut (50). **Make sure the Cable Trap is oriented as shown.**

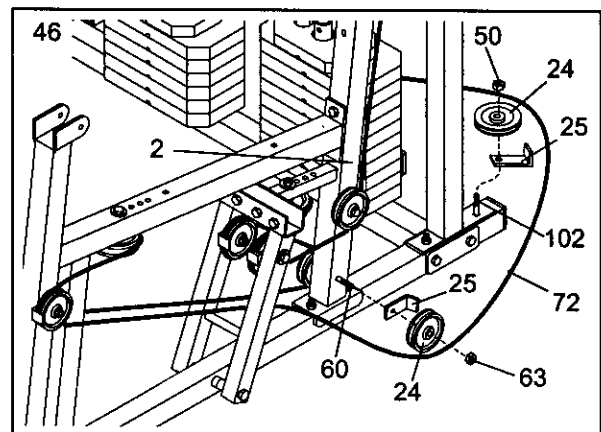

47. Route the threaded end of the Press Cable (72) around the 3 1/2" Pulley (24) that was mounted on the bracket on the Weight Base (5) in an earlier step.

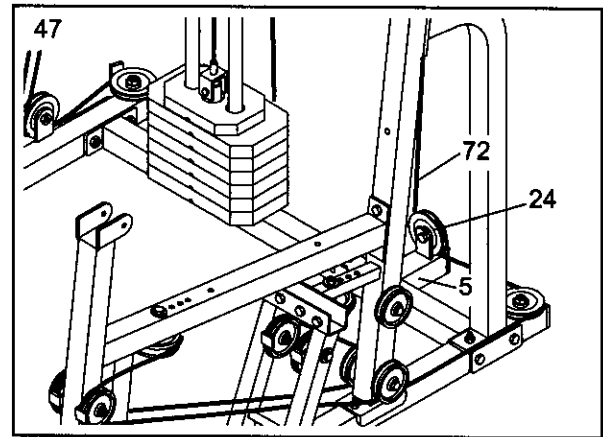

48. Wrap the Press Cable (72) over a 4 1/2" Pulley (82) in the direction shown. Attach the Pulley inside the indicated bracket on the Weight Top Frame (66) with a 3/8" x 1 3/4" Bolt (57) and a 3/8" Nylon Locknut (50). Make sure the end of the Cable is routed through the bracket, as shown.

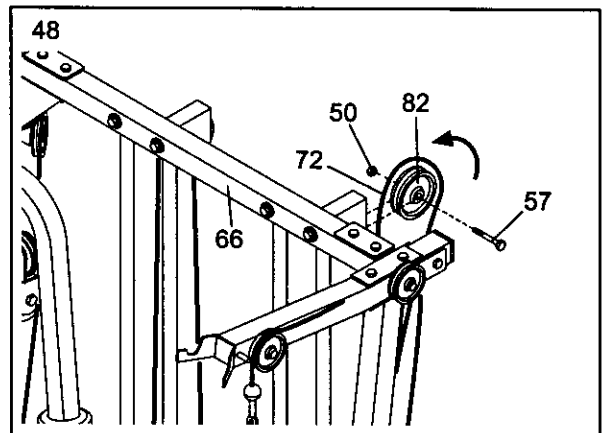

49. Attach the threaded end of the Press Cable (72) to the remaining "U"-Bracket (97) with a 1/4" Flat Washer (71) and a 1/4" Nylon Locknut (68).

Attach the "U"-Bracket (97) to the hole in the Long Weight Tube (70) with a 5/16" x 1 3/4" Bolt (96) and a 5/16" Nylon Locknut (64). **Note: Do not completely tighten the Nylon Locknut; it should be threaded only two turns onto the end of the Cable, as shown in the inset drawing.**

Important: Follow all four cables from end to end and make sure that they rest in the grooves of all pulleys and that the cables and the pulleys move smoothly.

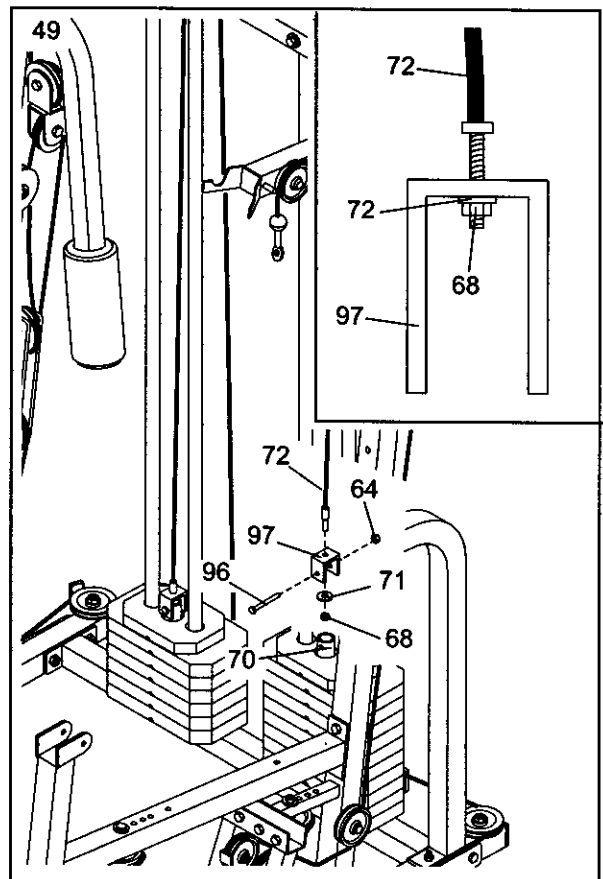

Seat Assembly

50. Locate and open the parts bag labeled "SEAT ASSEMBLY."

Attach the Backrest (12) to the indicated holes in the Butterfly Upright (1) with two 1/4" x 2 1/2" Bolts (79) and two 1/4" Flat Washers (71).

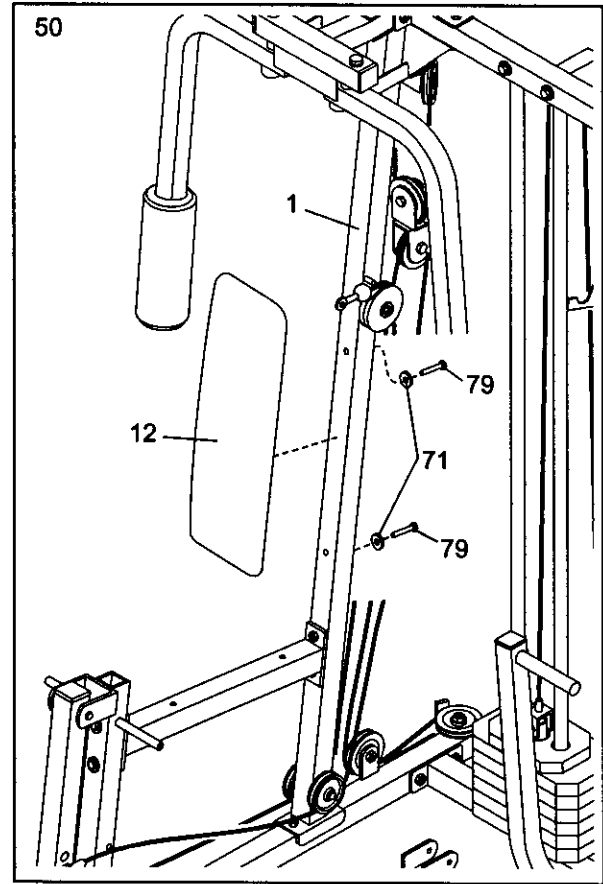

51. Insert a 1/4" x 2 1/2" Carriage Bolt (45) through the center hole in a Seat Plate (65). Attach the Seat Plate to the Press Backrest (99) with two 1/4" x 3/4" Bolts (49).

Insert the 1/4" x 2 1/2" Carriage Bolt (45) into the indicated hole in the Butterfly Upright (2) and secure it with a 1/4" Flat Washer (71) and a 1/4" Nylon Locknut (68). Secure the other end of the Press Backrest (99) with a 1/4" x 2 1/2" Bolt (79) and a 1/4" Flat Washer (71).

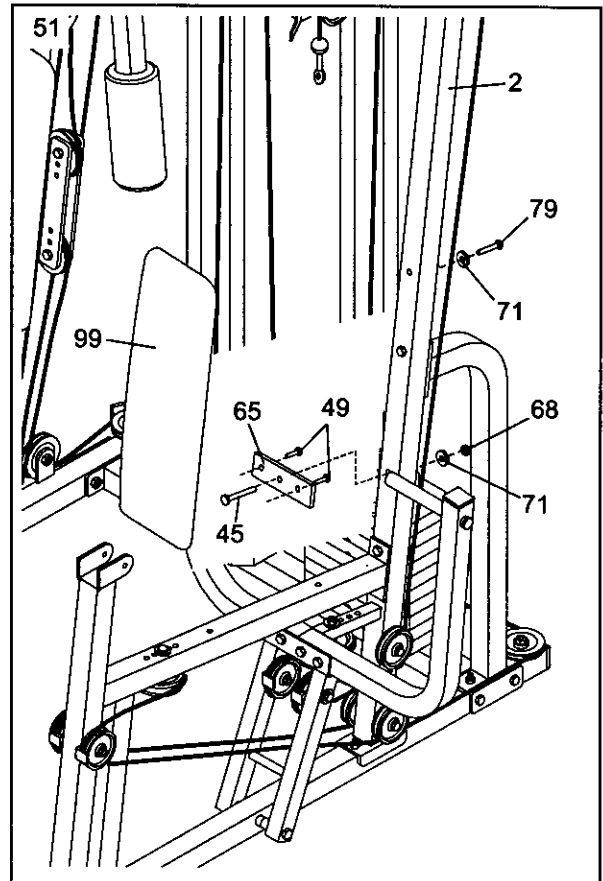

52. Insert a 1/4" x 2 1/2" Carriage Bolt (45) through the center hole in a Seat Plate (65). Attach the Seat Plate to a Seat (13) with two 1/4" x 3/4" Bolts (49).

Insert the 1/4" x 2 1/2" Carriage Bolt (45) into the indicated hole in the Butterfly Seat Frame (14) and secure it with a 1/4" Flat Washer (71) and a 1/4" Nylon Locknut (68). Secure the other end of the Seat (13) with a 1/4" x 2 1/2" Bolt (79) and a 1/4" Flat Washer (71).

Attach the other Seat (13) to the Press Seat Frame (7, not shown) in the same manner.

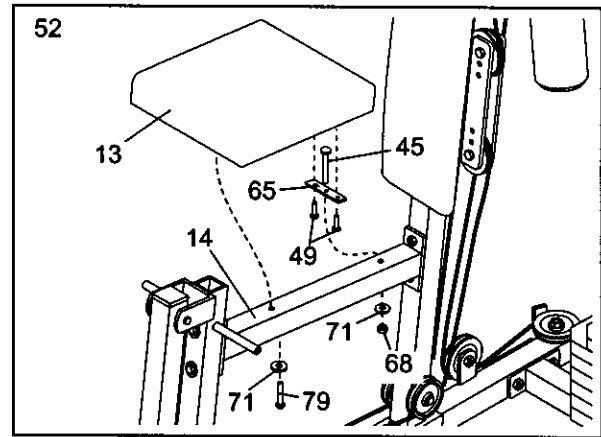

Miscellaneous Assembly

53. Press 3/4" Round Inner Caps (43) into the ends of the Pad Tube (42) and the indicated tube on the Front Leg (20).

Insert the Pad Tube (42) into the indicated hole in the Small Leg Lever (41). Slide Foam Pads (30) onto the ends of the Pad Tube and the tube on the Leg Lever.

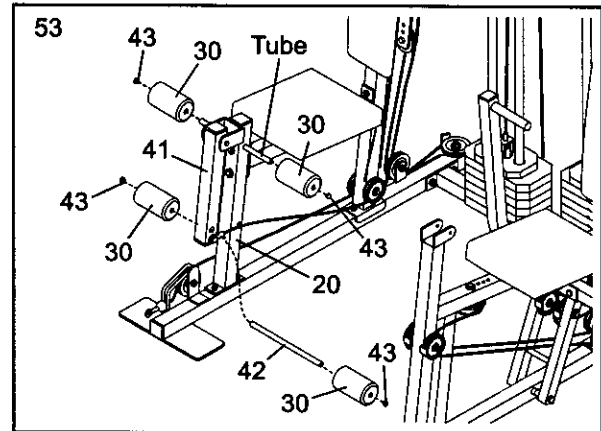

54. Press a 1 3/4" Square Inner Cap (35) into the indicated end of the Adjustment Tube (90).

Attach the Adjustment Tube (90) to the bracket (not visible in the drawing) on the back of the Leg Press Plate (55) with a 5/16" x 2 1/2" Bolt (87), two 5/16" Washers (36), and a 5/16" Nylon Locknut (64).

Attach the Leg Press Plate (55) to the Leg Press Lever (83) by placing the Adjustment Tube (90) into the bracket on top of the Leg Press Lever and securing it with the Lock Pin (91). **Note: The lip on the Leg Press Plate must be on the upper edge.**

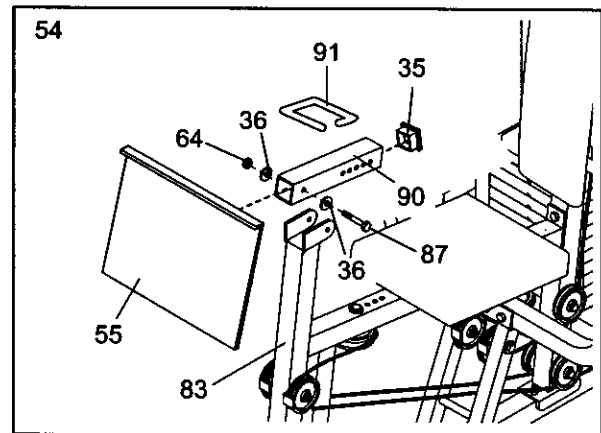

55. Attach the Curl Pad (105) to the Curl Post (104) with two 1/4" x 3/4" Bolts (49).

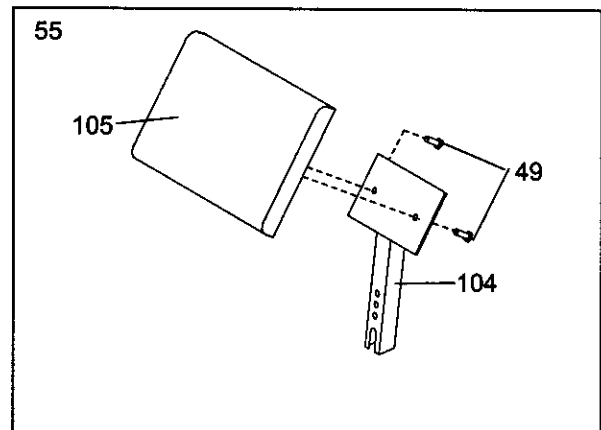

56. Apply the WEIDER PRO 9940 decal in the location shown. **Important:** The warning decals shown below have been attached to the home gym in the locations shown. If a decal is missing or illegible, please call our customer hotline at the number on the front cover of this manual to order a replacement decal. Apply the new decal in the appropriate location.

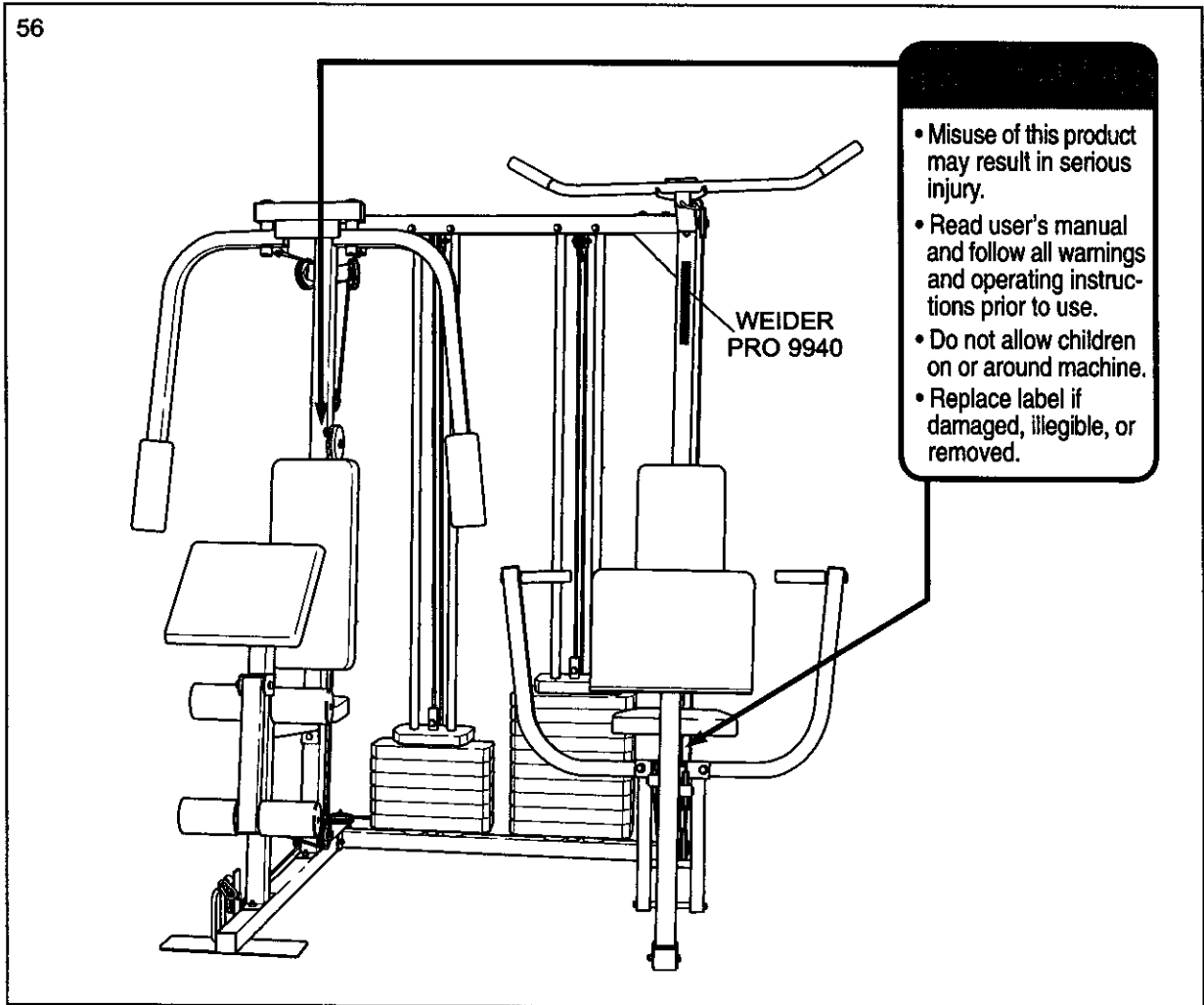

57. Make sure that all parts have been properly tightened. The use of the remaining parts will be explained in **ADJUSTMENT**, beginning on page 25 of this manual.

Before using the home gym, pull each cable a few times to make sure that the cables move smoothly over the pulleys. If one of the cables does not move smoothly, find and correct the problem. **IMPORTANT: If the cables are not properly installed, they may be damaged when heavy weight is used. If there is any slack in the cables, you will need to remove the slack by tightening the cables. See TROUBLE-SHOOTING AND MAINTENANCE on page 26.**

Cable Diagrams

The Cable Diagrams below and on the next page show the proper routing of the Butterfly Cable (73), the Ab Cable (74), the Low Pulley Cable (75) and the Press Cable (72). The numbers show the correct route for each Cable. Make sure that the Cables are routed correctly, that the Pulleys move smoothly, and that the Cable Traps do not touch or bind the Cables. Incorrect cable routing can damage the home gym.

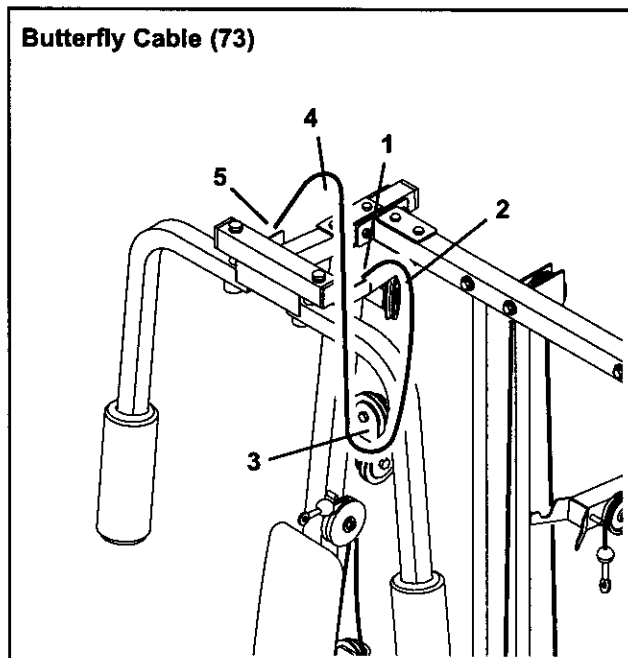
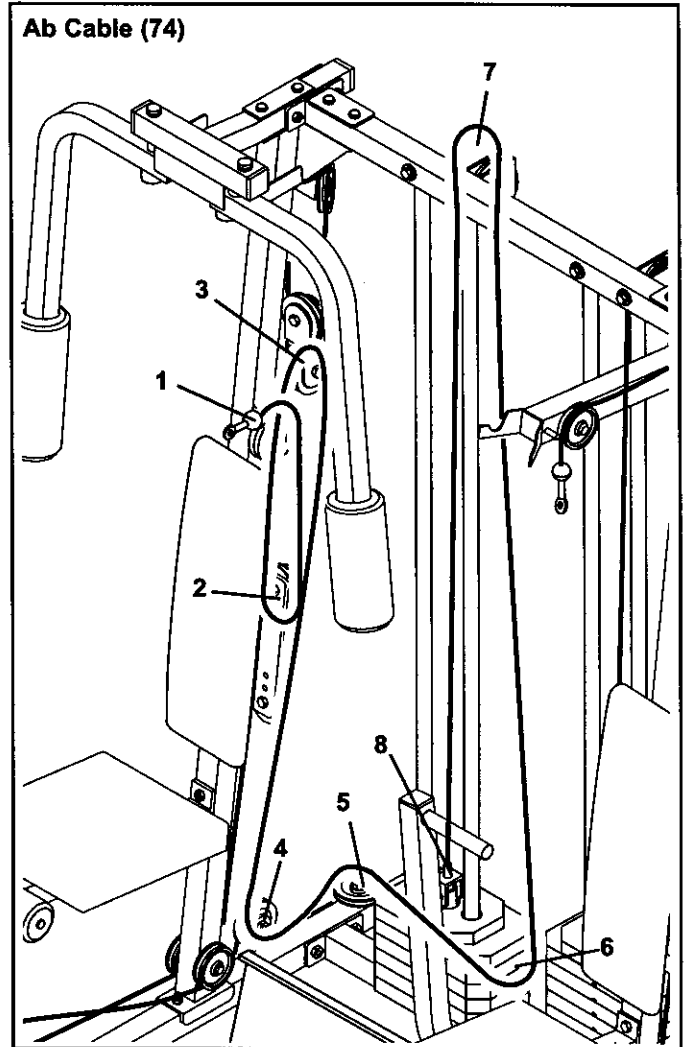
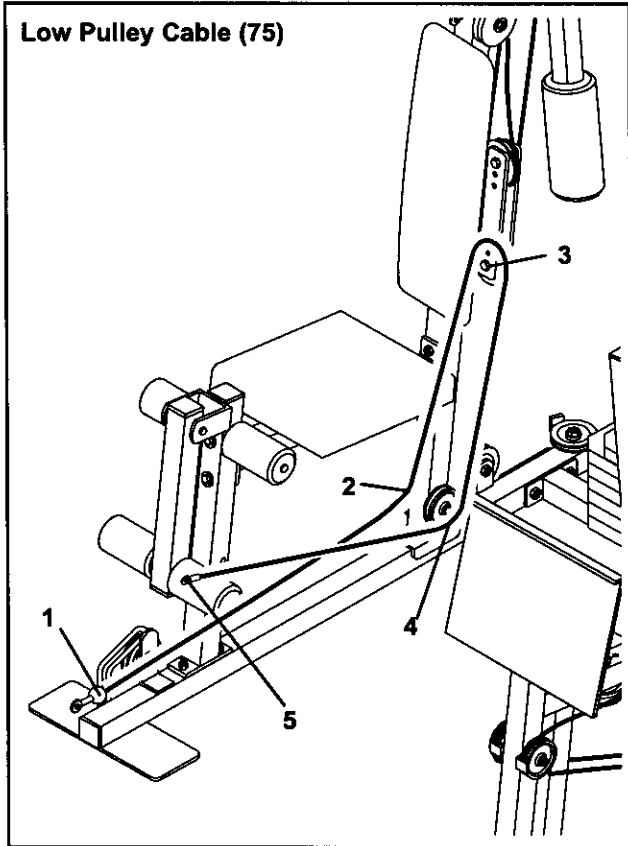

Cable ID Chart

73, 52"	
75, 143.5"	
74, 224"	
72, 389.5"	

Press Cable (72)

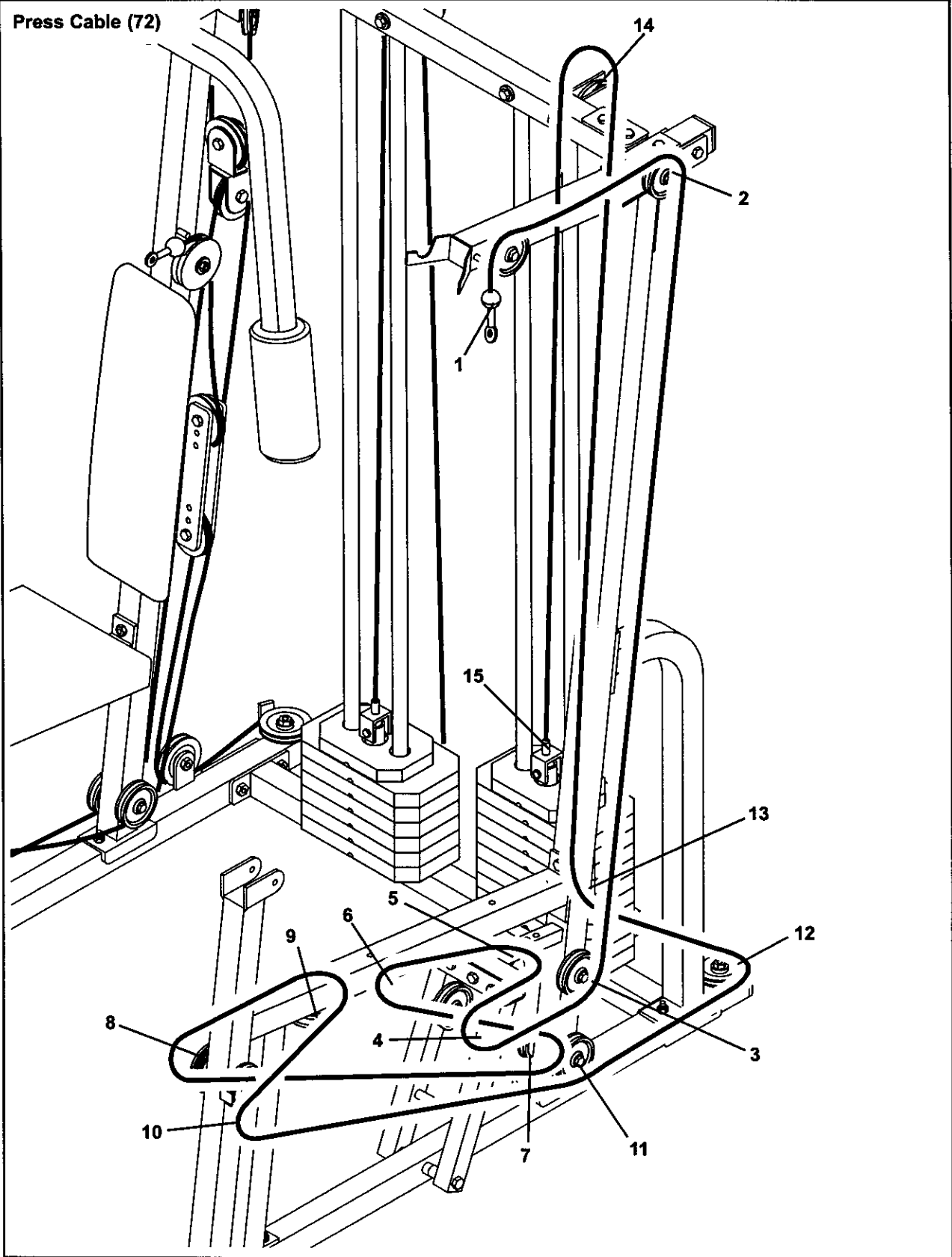

Adjustment

The instructions below describe how each part of the home gym can be adjusted. Refer to the exercise poster accompanying this manual to see how the home gym should be set up for each exercise. **IMPORTANT: When using an attachment, make sure it is in the correct starting position for the exercise to be performed. If there is any slack in the cables or chain as an exercise is performed, the effectiveness of the exercise will be reduced.**

Changing the Weight Setting

To change the setting of the weight stack, insert a Weight Pin (19) under the desired Weight (21). Make sure you insert the Weight Pin as far as it will go. **Note: Due to the cables and pulleys, the amount of resistance at each exercise station may vary from the weight setting. Use the WEIGHT RESISTANCE CHART on page 27 to find the approximate amount of resistance at each weight station.**

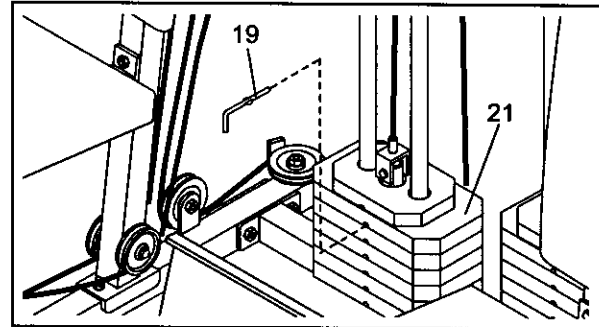

Attaching the Lat Bar, Nylon Strap or Ab Strap to the Low Pulley Station

Attach the Lat Bar (61) to the Low Pulley Cable (75) with a Cable Clip (69). For some exercises, the Chain (67) should be attached between the Lat Bar and the Low Pulley Cable with two Cable Clips. **Adjust the length of the Chain between the Lat Bar and the Low Pulley Cable so the Lat Bar is in the correct starting position for the exercise to be performed.**

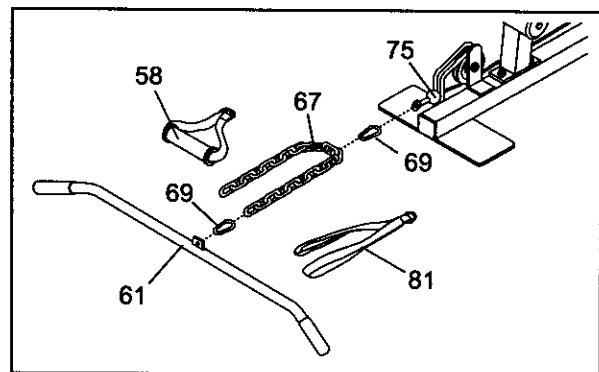

The Nylon Strap (58) or Ab Strap (81) can be attached in the same manner.

Attaching the Lat Bar, Nylon Strap or Ab Strap to the High Pulley Station

Attach the Lat Bar (61) to the Press Cable (72) with a Cable Clip (69). For some exercises, the Chain (67) should be attached between the Lat Bar and the High Cable with two Cable Clips. **Adjust the length of the Chain between the Lat Bar and the High Cable so the Lat Bar is in the correct starting position for the exercise to be performed.**

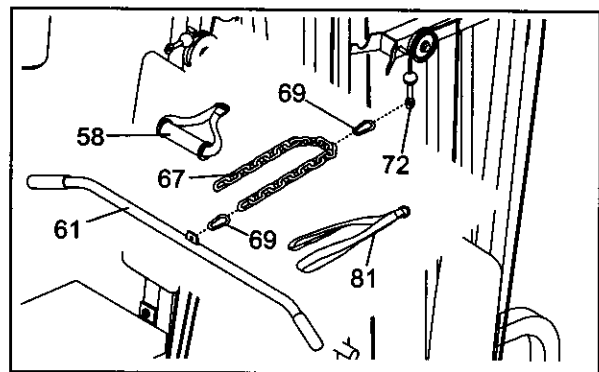

The Nylon Strap (58) or Ab Strap (81) can be attached in the same manner.

Adjusting the Leg Press Plate

To adjust the position of the Leg Press Plate (55), pull out the Lock Pin (91) and slide the Adjustment Tube (90) backwards or forwards in the bracket on the Leg Press Lever (83). Line up one of the adjustment holes in the Adjustment Tube with the hole in the bracket and re-insert the Lock Pin.

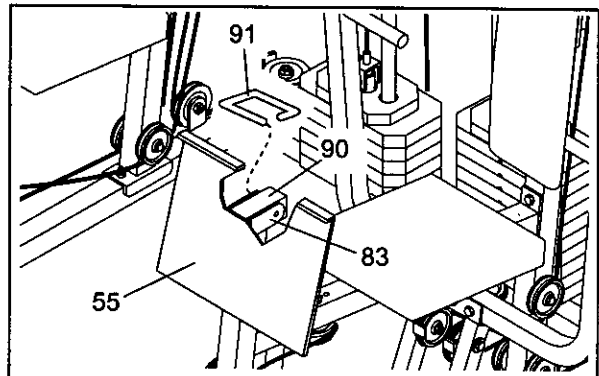

To use the Curl Pad (105), remove the 2" Square Inner Cap (28) from the Front Leg (20) and insert the Curl Post (104) into the Front Leg. Secure the Curl Pad by inserting the Adjustment Knob (103) at the desired height.

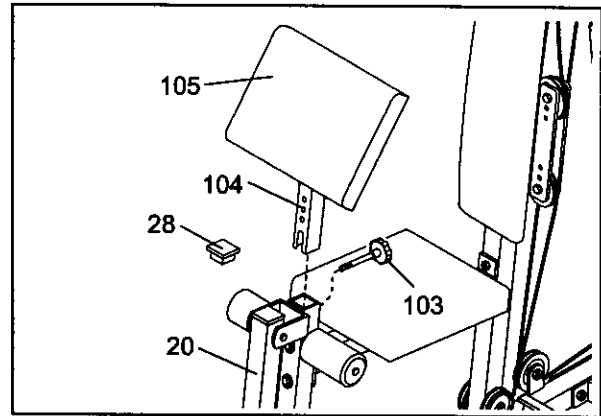

Trouble-shooting and Maintenance

Inspect and tighten all parts each time you use the home gym. Replace any worn parts immediately. The home gym can be cleaned using a damp cloth and mild non-abrasive detergent. Do not use solvents.

Tightening the Cables

If a cable slips off the pulleys often, the cable may have become twisted. Remove the cable and re-install it. If the cables need to be replaced, see ORDERING REPLACEMENT PARTS on the back cover of this manual.

The type of cable used on the home gym can stretch slightly when it is first used. If there is slack in the cables before resistance is felt, the cables should be tightened. Slack can be removed from the cables in several different ways:

The Adjustable Pulley Plates (23) have several sets of adjustment holes. By moving one or both pulleys (24) to a different set of holes, you will tighten the cables.

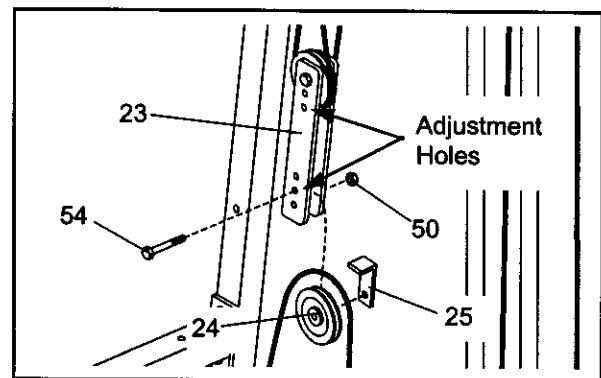

To move a Pulley (24), remove the 3/8" Nylon Locknut (50) and the 3/8" x 2" Bolt (54). Remove the Cable Trap (25) and Pulley from the Adjustable Pulley Plates (23). Re-attach the Pulley and Cable Trap to the appropriate adjustment hole in the Pulley Plates. **Note: Begin by moving one Pulley to the second adjustment hole. If the cables are still too loose, move the same Pulley to the third hole. If additional adjustment is needed, move the other Pulley until the cables are tight.**

Slack can be removed from the Press Cable (72) by moving one or both of the "V"-Pulleys (27) on the Press Cable.

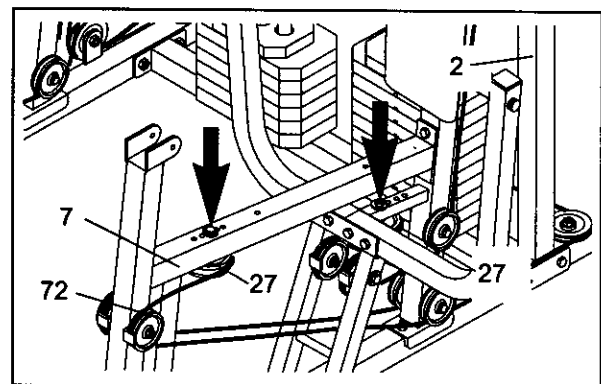

One "V"-Pulley (27) is attached to the small tube on the Press Upright (2). There are three free holes in the small tube, and you can move the "V"-Pulley to any one of them to tighten the cables. Start by moving the "V"-Pulley one hole, and then one more, as needed.

The second "V"-Pulley (27) is attached to the Press Seat Frame (7). There are five adjustment holes in the Seat Frame. By moving the "V"-Pulley closer to the Press Upright (2), you will tighten the cables. By moving it further away from the Upright, you will loosen the cables.

The threaded ends on the Press Cable (72) and the Ab Cable (74) that are attached to the weight stacks can also be used to tighten the cables.

To tighten the Ab Cable (74), remove the "U"-Bracket (97) from the Short Weight Tube (17) by removing the 5/16" x 1 3/4" Bolt (96) and the 5/16" Nylon Locknut (64).

Tighten the 1/4" Nylon Locknut (68) at the end of the Ab Cable (74) as far as it will go. Then re-attach the "U"-Bracket (97).

The Press Cable (72) can be tightened the same way.

When you are tightening the cables, take note that they are linked into two distinct groups. The Butterfly Cable (73), the Ab Cable (74), and the Low Pulley Cable (75) are all connected to the small weight stack. All three cables will be tightened by tightening the Ab Cable (74) as described above or by using the Adjustable Pulley Plates (23) as described on the previous page.

The Press Cable (72) is the only cable attached to the large weight stack. It must be tightened by using the method described above or by moving the "V"-Pulleys as described on the previous page.

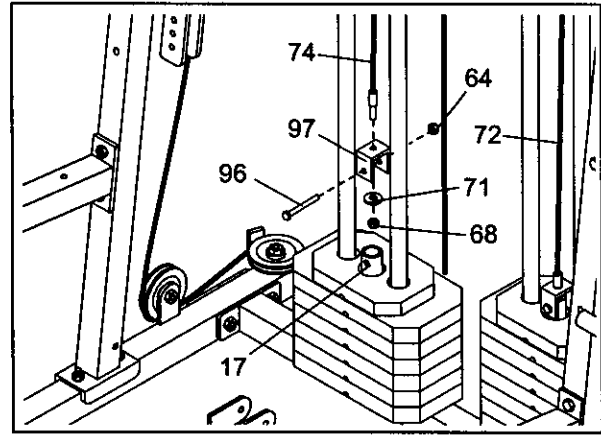

Weight Resistance Chart

The chart below shows the approximate weight resistance at each exercise station. "Top" refers to the 6 lb. top weight; the other numbers refer to the 12.5 lb. weight plates. **Note: The actual resistance at each station may vary due to differences in individual weight plates as well as friction between the cables, pulleys, and weight guides.**

Weight Plates	High Pulley (lbs.)	Arm Press (lbs.)	Leg Press (lbs.)	Butterfly (lbs.)	Curl/ Low Pulley (lbs.)	Ab Pulley/ Leg Raise (lbs.)
Top	14	16	21	8	10	8
1	28	37	48	23	24	21
2	42	58	75	38	37	35
3	56	79	101	52	50	48
4	69	100	128	67	64	62
5	83	121	155	82	77	76
6	97	142	181	97	90	89
7	111	163	208			
8	124	184	235			
9	138	205	262			
10	152	226	288			

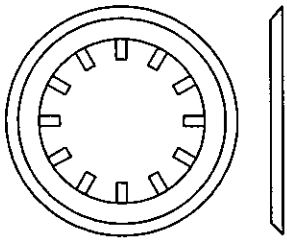

1" Retainer Ring (31)

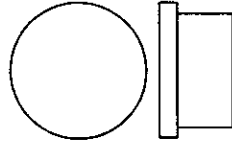

3/4" Round Inner Cap (43)

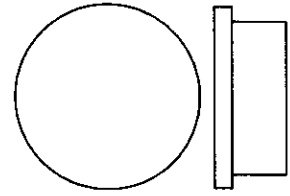

1" Round Inner Cap (86)

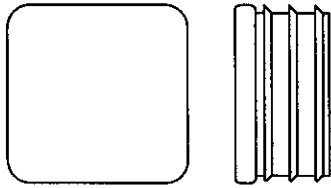

1" Square Inner Cap (98)

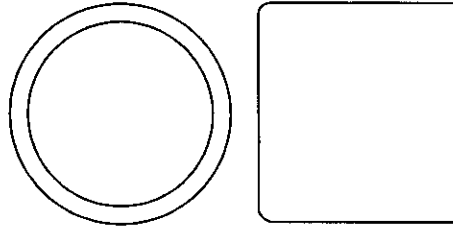

1" Round Outer Cap (38)

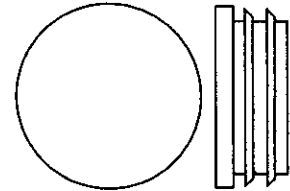

1" Round Inner Cap (76)

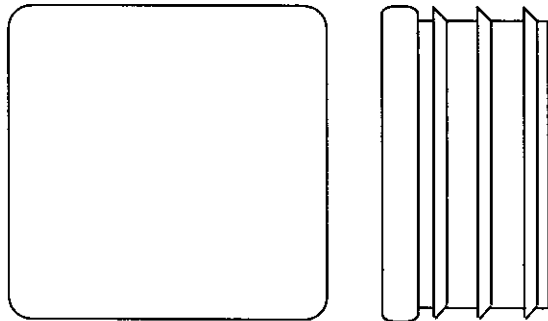

1 3/4" Square Inner Cap (35)

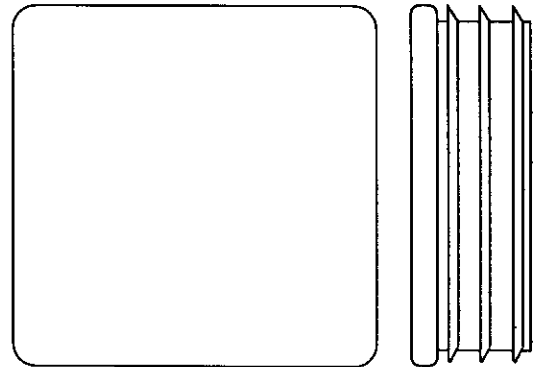

2" Square Inner Cap (28)

Part Identification Chart—Model No. 831.159730

R0800A

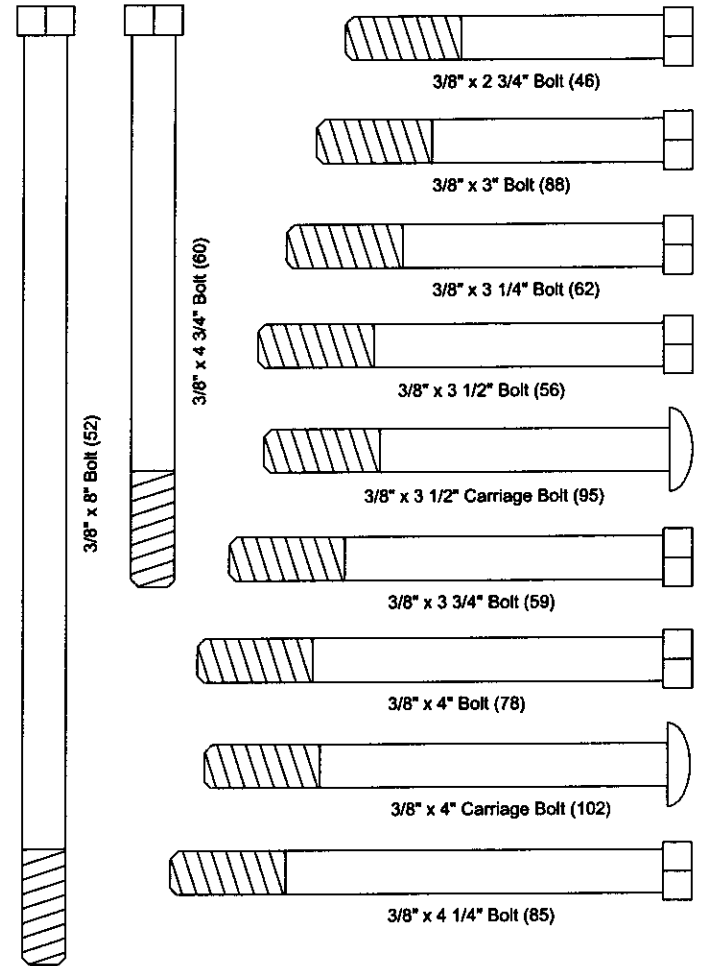
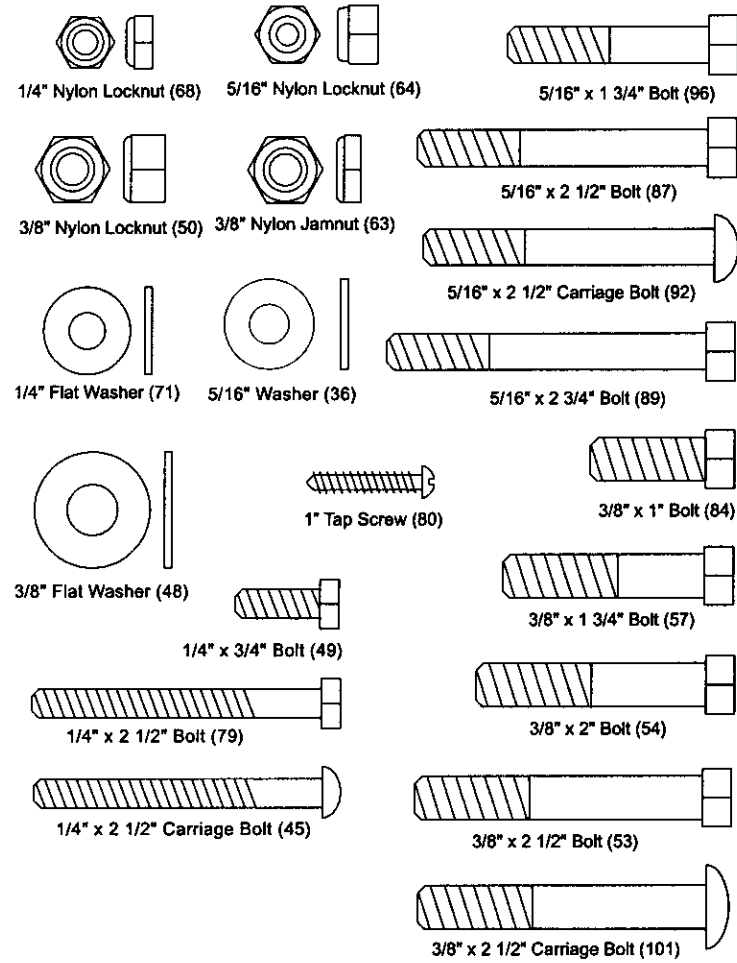

Part List—Model No. 831.159730

R0800A

Key No.	Qty.	Description	Key No.	Qty.	Description
1	1	Butterfly Upright	55	1	Leg Press Plate
2	1	Press Upright	56	1	3/8" x 3 1/2" Bolt
3	1	Support Frame	57	6	3/8" x 1 3/4" Bolt
4	1	Butterfly Base	58	1	Nylon Strap
5	1	Weight Base	59	6	3/8" x 3 3/4" Bolt
6	1	Press Base	60	3	3/8" x 4 3/4" Bolt
7	1	Press Seat Frame	61	1	Lat Bar
8	1	Press Frame	62	4	3/8" x 3 1/4" Bolt
9	1	Press Top Frame	63	15	3/8" Nylon Jamnut
10	1	Left Butterfly Arm	64	31	5/16" Nylon Locknut
11	1	Right Butterfly Arm	65	3	Seat Plate
12	1	Backrest	66	1	Weight Top Frame
13	2	Seat	67	1	Chain
14	1	Butterfly Seat Frame	68	5	1/4" Nylon Locknut
15	4	Weight Guide	69	3	Cable Clip
16	2	Top Weight	70	1	Long Weight Tube
17	1	Short Weight Tube	71	10	1/4" Flat Washer
18	2	Weight Tube Bumper	72	1	Press Cable
19	2	Weight Pin	73	1	Butterfly Cable
20	1	Front Leg	74	1	Ab Cable
21	16	Weight	75	1	Low Pulley Cable
22	1	Small Pulley Bracket	76	2	1" Round Inner Cap
23	2	Adjustable Pulley Plate	77	2	Press Arm
24	20	3 1/2" Pulley	78	1	3/8" x 4" Bolt
25	16	Cable Trap	79	5	1/4" x 2 1/2" Bolt
26	2	Pro Pulley	80	1	1" Tap Screw
27	4	"V"-Pulley	81	1	Ab Strap
28	13	2" Square Inner Cap	82	2	4 1/2" Pulley
29	2	Butterfly Foam Pad	83	1	Leg Press Lever
30	4	Foam Pad	84	2	3/8" x 1" Bolt
31	4	Retainer Ring	85	1	3/8" x 4 1/4" Bolt
32	4	Large Cable Trap	86	2	1" Round Inner Cap
33	1	Butterfly Top Frame	87	5	5/16" x 2 1/2" Bolt
34	2	Support Plate, 2 1/2" Center Holes	88	1	3/8" x 3" Bolt
35	7	1 3/4" Square Inner Cap	89	14	5/16" x 2 3/4" Bolt
36	8	5/16" Washer	90	1	Adjustment Tube
37	2	Butterfly Arm Bushing	91	1	Lock Pin
38	2	1" Round Outer Cap	92	10	5/16" x 2 1/2" Carriage Bolt
39	4	5" Plastic Grip	93	4	Support Plate, 3 1/2" Center Holes
40	1	Bumper	94	2	Support Plate, 4" Center Holes
41	1	Small Leg Lever	95	1	3/8" x 3 1/2" Carriage Bolt
42	1	Pad Tube	96	2	5/16" x 1 3/4" Bolt
43	4	3/4" Round Inner Cap	97	2	"U"-bracket
44	2	Large Bushing	98	1	1" Square Inner Cap
45	3	1/4" x 2 1/2" Carriage Bolt	99	1	Press Backrest
46	10	3/8" x 2 3/4" Bolt	100	2	Plastic Bushing
47	2	Pulley Cover	101	1	3/8" x 2 1/2" Carriage Bolt
48	18	3/8" Flat Washer	102	1	3/8" x 4" Carriage Bolt
49	8	1/4" x 3/4" Bolt	103	1	Adjustment Knob
50	32	3/8" Nylon Locknut	104	1	Curly Post
51	4	Weight Bumper	105	1	Curly Pad
52	1	3/8" x 8" Bolt	#	1	User's Manual
53	2	3/8" x 2 1/2" Bolt	#	1	Exercise Poster
54	4	3/8" x 2" Bolt			

Note: "#" indicates a non-illustrated part. Specifications are subject to change without notice.

Exploded Drawing—Model No. 831.159730

R0800A

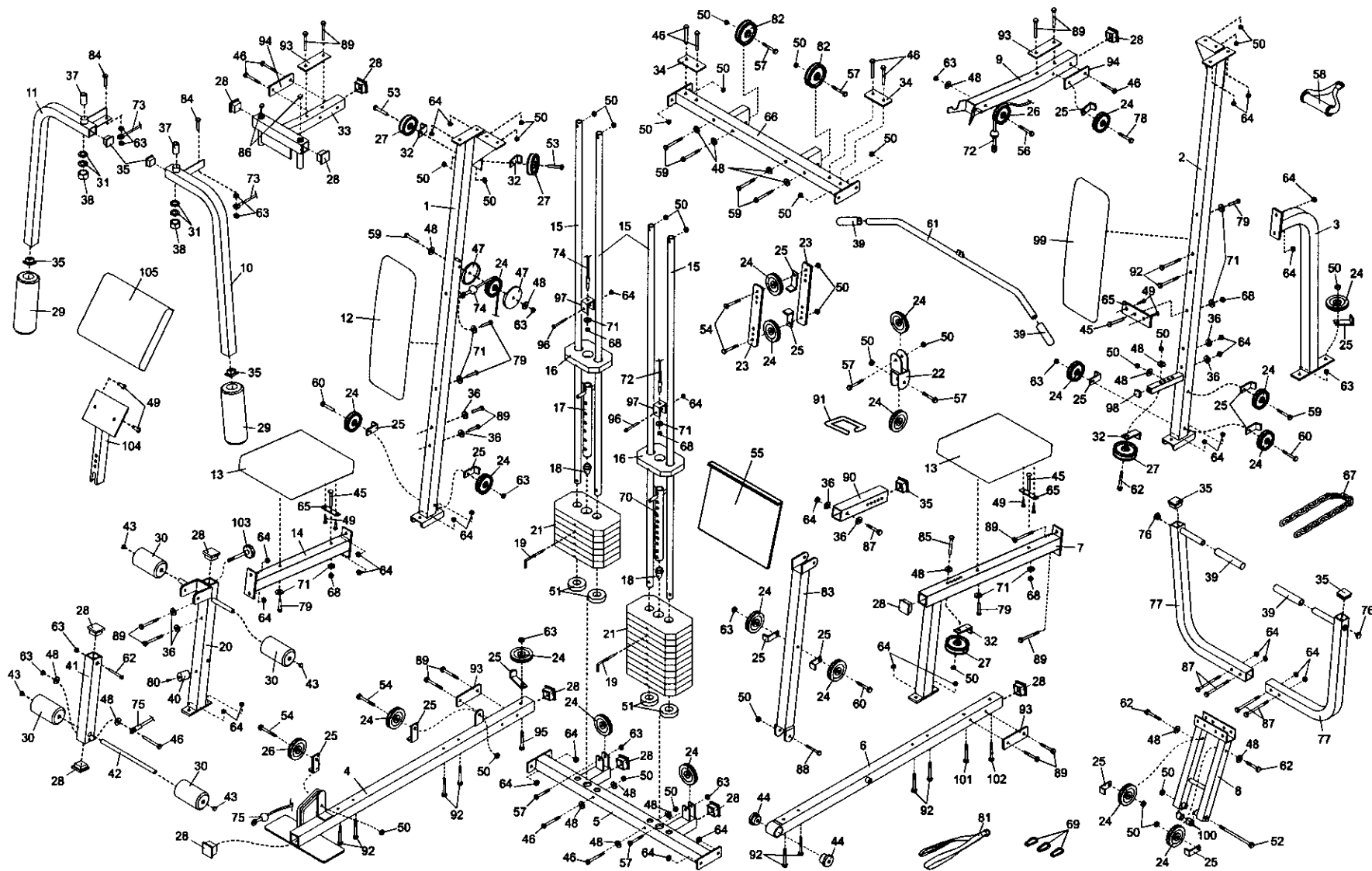



Model No. 831.159730

QUESTIONS?

If you find that:

- you need help assembling or operating the WEIDER® PRO 9940 Home Gym
- a part is missing
- or you need to schedule repair service

call our toll-free HELPLINE

1-800-736-6879

Monday–Saturday, 7 am–7 pm
Central Time (excluding holidays)

REPLACEMENT PARTS

If parts become worn and need to be replaced, call the following toll-free number

1-800-FON-PART
(1-800-366-7278)

The model number and serial number of your WEIDER® PRO 9940 Home Gym are listed on a decal attached to the frame. See the front cover of this manual to find the location of the decal.

All replacement parts are available for immediate purchase or special order when you visit your nearest SEARS Service Center. To request service or to order parts by telephone, call the toll-free numbers listed at the left.

When requesting help or service, or ordering parts, please be prepared to provide the following information:

- The MODEL NUMBER of the product (831.159730)
- The NAME of the product (WEIDER® PRO 9940 Home Gym)
- The KEY NUMBER and DESCRIPTION of the PART (see the PART LIST/EXPLODED DRAWING in the center of this manual).

SEARS, ROEBUCK AND CO., HOFFMAN ESTATES, IL 60179

FULL 90 DAY WARRANTY

For 90 days from the date of purchase, if failure occurs due to defect in material or workmanship in this SEARS WEIGHT SYSTEM EXERCISER, contact the nearest SEARS Service Center throughout the United States and SEARS will repair or replace the WEIGHT SYSTEM EXERCISER, free of charge.

This warranty does not apply when the WEIGHT SYSTEM EXERCISER is used commercially or for rental purposes.

This warranty gives you specific legal rights, and you may also have other rights which vary from state to state.

SEARS, ROEBUCK AND CO., DEPT. 817WA, HOFFMAN ESTATES, IL 60179