

GE Monogram[®]

Use and Care Guide

30" Wall Oven

Introduction

Your new Monogram wall oven makes an eloquent statement of style, convenience and kitchen planning flexibility. Whether you chose it for its purity of design, assiduous attention to detail—or for both of these reasons—you’ll find that your Monogram wall oven’s superior blend of form and function will delight you for years to come.

Your Monogram wall oven was designed to provide the flexibility to blend in with your kitchen cabinetry. Its sleek design can be beautifully integrated into the kitchen.

The information on the following pages will help you operate and maintain your wall oven properly.

If you have any other questions—please call the GE Answer Center® 800.626.2000.

Contents

Care and Cleaning

Broiler Pan, Grid, and
Convection Roasting Rack 22
Oven Door 24
Oven Lights 23
Shelves 22

Consumer Services

Important Phone Numbers 29
Model and Serial Number 3, 32
Problem Solver 25
Product Registration 3, 31, 32
Safety Instructions 4-6
Warranty 30

Oven

Adjust the Oven Thermostat 17
Aluminum Foil 5, 11, 21
Baking/Roasting 9, 20, 21
Broiling/Broiling Guide 11, 12
Controls 7-9, 10, 11, 14-19
Convection Cooking 13, 14
Features 7
Proofing 10
Self-Cleaning Instructions 18, 19
Timed Cooking 15, 16

*Before
using your
wall oven*

Read this guide carefully. It is intended to help you operate and maintain your new wall oven properly.
Keep it handy for answers to your questions.

If you don't understand something or need more help, call:

GE Answer Center®
800.626.2000
24 hours a day, 7 days a week

*Write
down the
model &
serial
numbers*

You'll find them on a label on the front trim behind the oven door.

These numbers are also on the Consumer Product Ownership Registration Card included in this guide.

Before sending in this card, please write these numbers here:

Model Number

Serial Number

Use these numbers in any correspondence or service calls concerning your wall oven.

*If you
received a
damaged
wall oven*

Immediately contact the dealer (or builder) that sold you the wall oven.

*Save time
& money*

Before you request service, check the Problem Solver in the back of this guide.

It lists causes of minor operating problems that you can correct yourself.

*If you
need
service*

To obtain service, see the Consumer Services page in the back of this guide.

We're proud of our service and want you to be pleased. If for some reason you are not happy with the service you receive, here are two steps to follow for further help.

FIRST, contact the people who serviced your appliance. Explain why you are not pleased. In most cases, this will solve the problem.

NEXT, if you are still not pleased, write all the details—including your phone number—to:

Manager, Consumer Relations
GE Appliances
Appliance Park
Louisville, KY 40225

IMPORTANT SAFETY INSTRUCTIONS

IMPORTANT SAFETY NOTICE

- **The California Safe Drinking Water and Toxic Enforcement Act** requires the Governor of California to publish a list of substances known to the state to cause cancer, birth defects or other reproductive harm, and requires businesses to warn customers of potential exposure to such substances.
- **The fiberglass insulation in self-clean ovens gives off a very small amount of carbon monoxide during the cleaning cycle.** Exposure can be minimized by venting with an open window or using a ventilation fan or hood.

SAFETY PRECAUTIONS

When using your appliance, follow basic safety precautions, including the following:

- **Be sure all packing materials are removed from the oven** before operating it to prevent fire or smoke damage should the packing material ignite.
- **Use this appliance only for its intended use** as described in this guide.
- **Be sure your appliance is properly installed and grounded** by a qualified technician in accordance with the provided installation instructions.
- **Be sure the oven is securely installed in a cabinet that is firmly attached to the house structure.** Never allow anyone to climb, sit, stand or hang on the oven door.
- **Have the installer show you the location of the circuit breaker or fuse.** Mark it for easy reference.
- **Do not attempt to repair or replace any part of your wall oven unless it is specifically recommended in this guide.** All other servicing should be referred to a qualified technician.
- **Teach children not to play with the controls** or any other part of the oven.
- **Never leave the oven door open** when you are not watching the oven.
- **Always keep dish towels, dish cloths, pot holders and other linens a safe distance from your oven.**
- **For your safety, never use your appliance for warming or heating the room.**
- **Do not store flammable materials in the oven.**
- **Always keep wooden and plastic utensils and canned food a safe distance away from your oven.**
- **Always keep combustible wall coverings, curtains or drapes a safe distance from your oven.**
- **DO NOT STORE OR USE COMBUSTIBLE MATERIALS, GASOLINE OR OTHER FLAMMABLE VAPORS AND LIQUIDS IN THE VICINITY OF THIS OR ANY OTHER APPLIANCE.**
- **Do not let cooking grease or other flammable materials accumulate in or near the wall oven.**
- **Do not use water on grease fires.** Smother fire or flame or use a multi-purpose dry chemical or foam-type fire extinguisher.

Flame in the oven can be smothered completely by closing the oven door and turning the oven off or by using a multi-purpose dry chemical or foam-type fire extinguisher.

SAFETY PRECAUTIONS

- **Do not use aluminum foil to line oven bottoms, except as suggested in this guide.** Improper installation of aluminum foil may result in a risk of electric shock or fire.
 - **Cook meat and poultry thoroughly**—meat to at least an INTERNAL 160°F and poultry to at least an INTERNAL 180°F. Cooking to these temperatures usually protects against foodborne illness.
 - **Before performing any service, DISCONNECT THE OVEN POWER SUPPLY AT THE HOUSEHOLD DISTRIBUTION PANEL BY REMOVING THE FUSE OR SWITCHING OFF THE CIRCUIT BREAKER.**
 - **Do not leave children alone**—children should not be left alone or unattended in an area where an appliance is in use. They should never be allowed to sit or stand on any part of the appliance.
 - **Do not touch the heating elements or the interior surface of the oven.** These surfaces may be hot enough to burn even though they are dark in color. During and after use, do not touch, or let clothing or other flammable materials contact, any interior area of the oven; allow sufficient time for cooling first.
- **CAUTION: ITEMS OF INTEREST TO CHILDREN SHOULD NOT BE STORED IN CABINETS ABOVE A WALL OVEN—CHILDREN CLIMBING ON THE OVEN TO REACH ITEMS COULD BE SERIOUSLY INJURED.**
 - **Never wear loose-fitting or hanging garments while using the appliance.** Be careful when reaching for items stored over the oven. Flammable material could be ignited if brought in contact with oven heating elements and may cause severe burns.
 - **Use only dry pot holders**—moist or damp pot holders on hot surfaces may result in burns from steam. Do not let pot holders touch oven heating elements. Do not use a towel or other bulky cloth.
 - **Keep the oven vent unobstructed.**
 - **Keep the oven free from grease buildup.**
 - **Stand away from the oven when opening the oven door.** Hot air or steam which escapes can cause burns to hands, face and/or eyes.
 - **Never “open door broil” with children nearby.** They could quickly come into contact with a hot oven interior surface, causing severe burns.

Potentially hot surfaces include the oven vent openings and surfaces near the openings, crevices around the oven door, the edges of the door window and metal trim parts above the door.

Remember: The inside surface of the oven may be hot when the door is opened.

IMPORTANT SAFETY INSTRUCTIONS

SAFETY PRECAUTIONS

- **Children in walkers, or children crawling, can be attracted to the round oven door handle and may grab and open the oven door.** This can result in injury from the door being pulled open on a child, or severe burns if the oven is in use and hot.
 - **Do not heat unopened food containers.** Pressure could build up and the container could burst, causing an injury.
 - **Place the oven shelf in the desired position while the oven is cool.** If shelves must be handled when hot, do not let pot holder contact the heating elements.
 - **Pulling out the shelf to the shelf stop is a convenience in lifting heavy foods.** It is also a precaution against burns from touching hot surfaces of the door or oven walls.
 - **When using cooking or roasting bags in the oven,** follow the manufacturer's directions.
 - **Do not use your oven to dry newspapers.** If overheated, they can catch on fire.
 - **Do not use oven for a storage area.** Items stored in an oven can ignite.
 - **Do not leave paper products, cooking utensils or food in the oven when not in use.**
 - **Do not allow anyone to climb, stand or hang on the door.** They could damage the oven or cause severe personal injury.
-

SELF-CLEANING OVEN

- **Do not clean the door gasket.** The door gasket is essential for a good seal. Care should be taken not to rub, damage or move the gasket.
- **Do not use oven cleaners.** No commercial oven cleaner or oven liner protective coating of any kind should be used in or around any part of the oven. Residue from oven cleaners will damage the inside of the oven when the self-clean cycle is used.
- **Clean only parts listed in this Use and Care Guide.**
- **Before self-cleaning the oven,** remove the oven shelves, broiler pan, grid and other cookware.
- **Be sure to wipe up excess spillage before starting the self-cleaning operation.**
- **If the self-cleaning mode malfunctions,** turn the oven off and disconnect the power supply. Have it serviced by a qualified technician.

SAVE THESE INSTRUCTIONS

Features of Your Wall Oven

Wall Oven

Design information

(Not all features are on all models. Appearance may vary.)

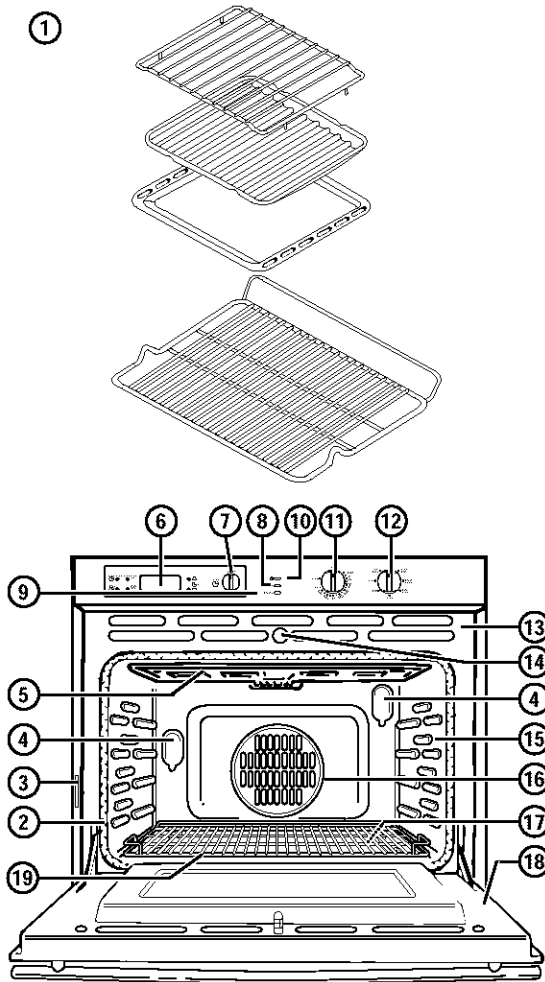

ZET837

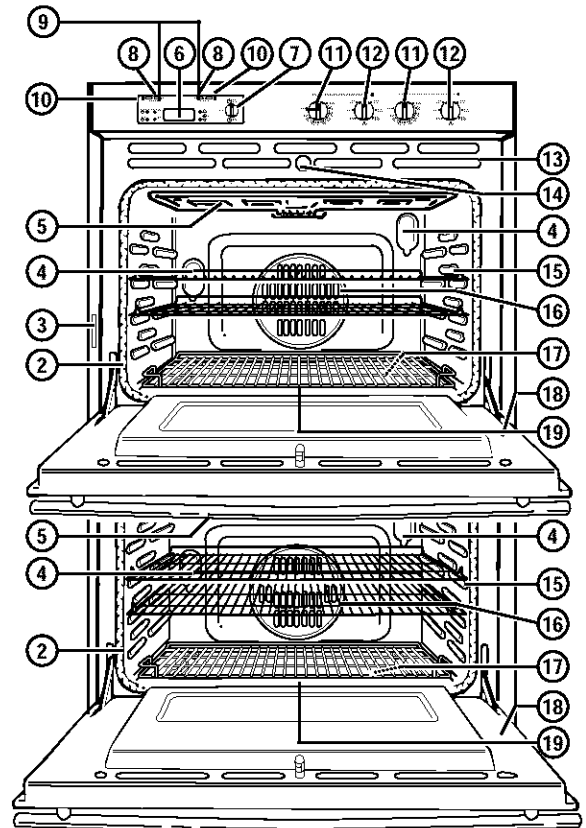

ZET857

Feature Index	Page
1 Oven Shelf, Broiler Pan, Grid, and Convection Roasting Rack	6, 9, 11, 12, 18, 22
2 Oven Door Gasket	6, 18, 24
3 Model and Serial Numbers	3, 29
4 Oven Lights	23
5 Broil Element	11, 22
6 Clock and Timer	8, 10
7 Mode Selector Knob	9-11, 14-19, 22
8 Oven ON Light	9-11, 14-19
9 PREHEAT Light	21
10 Locked Door Indicator Light	18, 19
11 Temperature Control Knob	9-11, 14-19, 22
12 Oven Control Knob	9-11, 14-19, 22
13 Oven Vent	5
14 Automatic Oven Door Latch	18, 19
15 Oven Shelf Supports	9
16 Convection Fan	13
17 Bake Element (under the oven floor)	22
18 Oven Door	11
19 Convection Floor Rack	20

Clock and Timer

Wall Oven

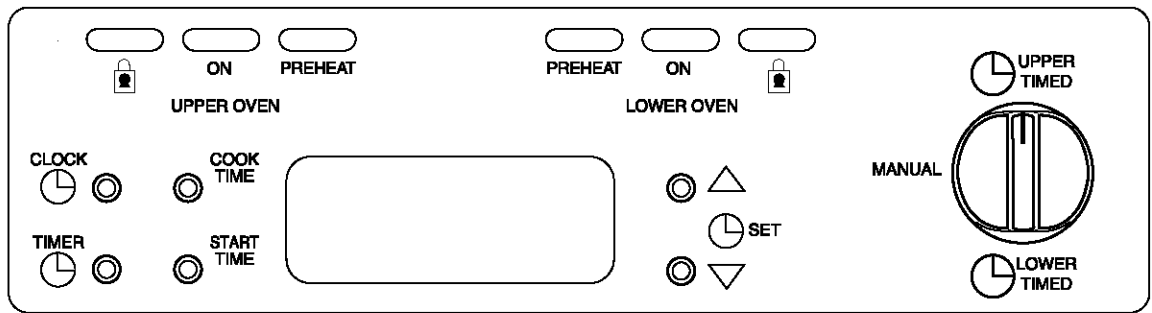

Double oven clock and timer

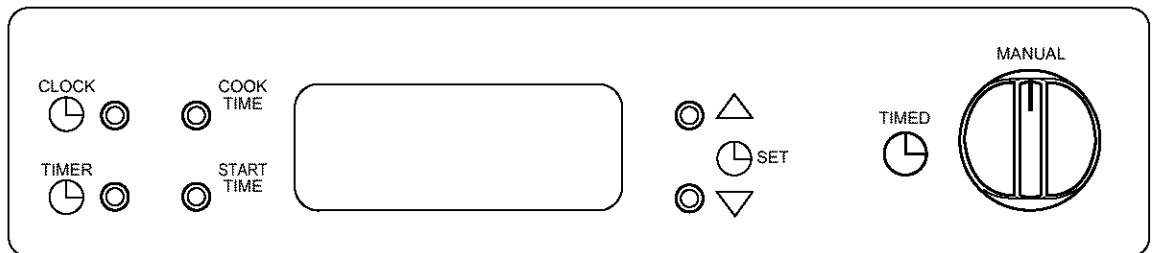

Single oven clock and timer

Using the clock and timer

When you first turn on the power to your oven, or after a power failure, the display will show all 8's, then dashes and the set clock symbol.

To set or change the time of day, press the CLOCK button. The control will beep. The set clock symbol will appear in the display.

Press the increase “▲” or decrease “▼” button.

If the increase “▲” or decrease “▼” button is pressed and released, it will change the time in one minute increments. If the increase “▲” or decrease “▼” button is pressed and held, the time will change in 10 minute increments.

Once the clock is set, press the CLOCK button again. The control will beep and the set clock symbol will disappear.

To check the time of day when the timer is in use press the CLOCK button. The time of day will be displayed briefly and then will return to the timer function.

The timer button does not control oven functions. The timer may be used as a convenient kitchen timer.

To set, press the TIMER button. The control will beep. The display will show “:00” and the words SET TIMER.

Press the increase “▲” or decrease “▼” button to set the amount of time desired.

If the increase “▲” or decrease “▼” button is pressed and released, it will change the time in one minute increments. If the increase “▲” or decrease “▼” button is pressed and held, the time will change in 10 minute increments.

The timer will start after approximately 4 seconds. The colon blinks when the timer starts counting down. The word TIMER will remain in the display during the countdown. The timer will count down in minutes until the last minute, then it will count down in seconds.

When timing is complete the word TIMER will blink and the control will beep three times. The display will return to the time of day or any active programmed function and the control will beep twice every 10 seconds until any button is touched.

To cancel the timer, press the TIMER button once. If no time is set, the timer cancels itself after approximately 5 seconds. The time of day is then displayed.

Baking or Roasting

Wall Oven

How to set the oven for baking or roasting

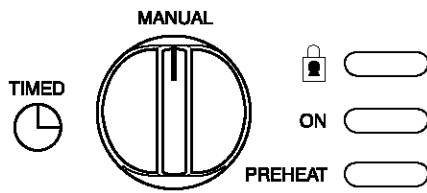

Mode selector knob

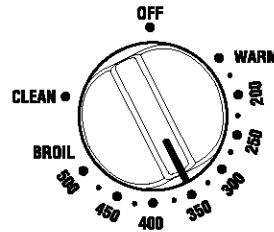

Temperature control knob

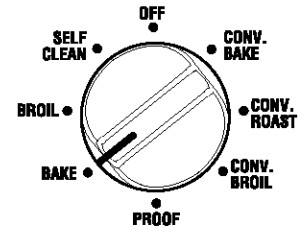

Oven control knob

Single oven controls shown.

- 1 Turn the mode selector knob to MANUAL.
- 2 Using the temperature control knob, set the desired temperature.
- 3 Turn the oven control knob to BAKE.

A cooling fan will automatically turn on to cool internal parts. This is normal, and the fan may continue to run even after the oven is turned off.

The oven ON light and the oven interior lights turn on and remain on until the oven control knob has been turned to OFF.

The PREHEAT light will come on and stay on until the oven temperature reaches the pre-set temperature. When the light goes off, foods with recipes requiring a preheated oven should be placed in the oven. This light will CYCLE on and off during the remainder of the cooking process.

NOTE: *These lights will not immediately come on if the mode selector knob is turned to TIMED.*

- 4 Check the food for doneness at the minimum time on the recipe. Cook longer if necessary.

- 5 Turn the oven control knob to OFF when baking is finished.

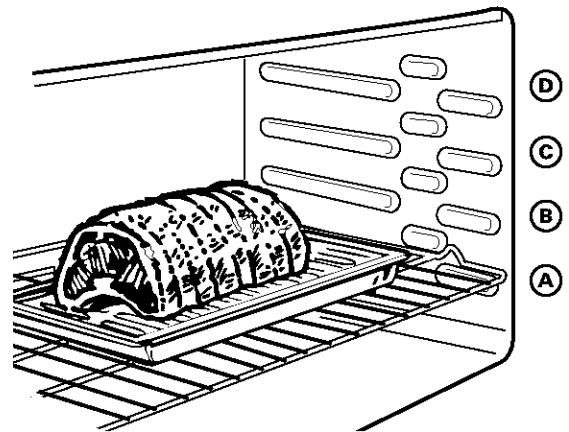

When roasting use the A or B shelf position.

NOTE: When roasting, check the weight of the meat. Place the meat fat side up, or for poultry, breast side up, on the roasting grid in a shallow pan. The melting fat will baste the meat. Select a pan as close to the size of the meat as possible. (The broiler pan with grid is a good pan for this.)

Type of Food	Shelf Position
Angel food cake	A
Biscuits or muffins	B or C
Cookies or cupcakes	B or C
Brownies	B or C
Layer cakes	B or C
Bundt or pound cakes	A
Pies or pie shells	A or C
Single Pie	B
Frozen pies	B (on cookie sheet)
Casseroles	B or C
Roasting	A or B

How to set the oven for proofing

The proofing feature maintains a warm environment useful for rising yeast-leavened products.

- 1 Place the covered dough in a dish in the oven on shelf A.
- 2 Turn the mode selector knob to MANUAL.

NOTE: For best results, cover the dough with a cloth or with greased plastic wrap (the plastic may need to be anchored underneath the front of the container so the oven fan will not blow it off).

- 3 Turn the oven control knob to PROOF.

The temperature control knob does not affect the proof temperature.

The oven ON light and the oven interior lights turn on and remain on until the oven control knob has been turned to OFF.

NOTE: The PREHEAT light does not come on during a PROOF operation.

- 4 Set the minute timer for the minimum proof time.
- 5 When proofing is finished, turn the oven control knob to OFF.

- To avoid lowering the oven temperature and lengthening proofing time, do not open the oven door unnecessarily.
- Check bread products early to avoid over-proofing.

NOTE: Do not use the proofing mode for warming food or keeping food hot. The proofing oven temperature is not hot enough to hold foods at safe temperatures.

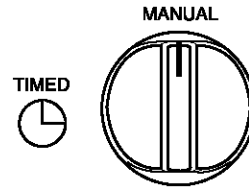

Mode selector knob

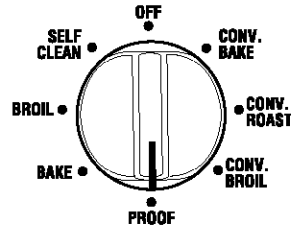

Oven control knob

Single oven controls shown.

How to set the oven for broiling

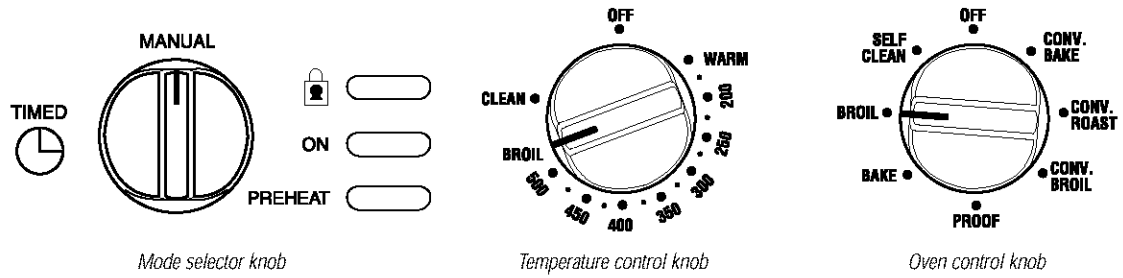

Single oven controls shown.

- 1 If the meat has fat or gristle around the edge, cut vertical slashes through both about 2 inches apart. If desired, the fat may be trimmed, leaving a layer about 1/8 inch thick.
- 2 Place the meat or fish on the broiler grid in the broiler pan. Always use the grid so that any fat will drip into the broiler pan; otherwise the juices may become hot enough to catch on fire.
- 3 Position a shelf on the recommended shelf position as suggested in the Broiling Guide.
- 4 Leave the door open to the broil stop position. The door will stay open by itself, yet the proper temperature is maintained in the oven.
- 5 Turn the mode selector knob to MANUAL.

NOTE: A cooling fan will turn on to cool internal parts. This is normal, and the fan may continue to run even after the oven is turned off.

- 6 Turn the temperature control knob and the oven control knob to BROIL.

The oven ON light and the oven interior lights turn on and remain on until the oven control knob has been turned to OFF.

The PREHEAT light turns on.

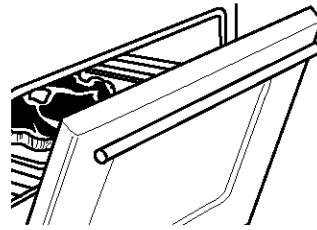

The oven door has a broil stop position.

The broiler does not need to be preheated for most broiling. However, foods that cook quickly, such as thin strips of meat or fish may require a short preheating period of 2 to 3 minutes to allow the food surface to brown in the same time the food takes to be cooked throughout.

Turn the food only once during broiling. Time the foods for the first side according to the Broiling Guide.

Use caution when reaching into the oven during broiling as areas above the door may be hot.

- 7 When broiling is finished, turn the oven control knob to OFF.

Aluminum foil

You can use aluminum foil to line the broiler pan and broiler grid. However, you must mold the foil tightly to the grid and cut slits in it just like the grid.

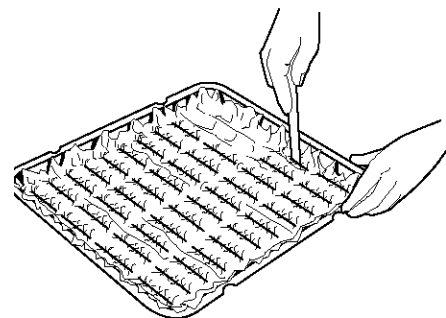

Broiling

Wall Oven

Broiling guide

Food	Quantity/ Thickness	Shelf Position	1st Side Minutes	2nd Side Minutes	Comments
Bacon	1/2 lb. (about 8 thin slices)	C	4½	4½	Arrange in single layer.
Ground Beef Well Done	1 lb. (4 patties) 1/2 to 3/4" thick	C	10	7	Space evenly. Up to 8 patties take about the same time.
Beef Steaks Rare Medium Well Done	1" thick (1 to 1½ lbs.)	C C C	6 8 12	5 6 11	Steaks less than 1" thick cook through before browning. Pan frying is recommended.
Rare Medium Well Done	1½" thick (2 to 2½ lbs.)	C C C	10 15 25	7-8 14-16 20-25	Slash fat.
Chicken	1 whole (2 to 2½ lbs.), split lengthwise	A	35	10-15	Reduce time about 5 to 10 minutes per side for cut-up chicken. Brush each side with melted butter. Broil skin-side- down first.
Bakery Products Bread (Toast) Toaster Pastries English Muffins	2 to 4 slices 1 pkg. (2) 2 (split)	C C C	1½-2 1½-2 3-4	1/2 1/2	Space evenly. Place English muffins cut- side-up and brush with butter, if desired.
Lobster Tails	2-4 (6 to 8 oz. each)	B	13-16	<i>Do not turn over.</i>	Cut through back of shell. Spread open. Brush with melted butter before broiling and after half of broiling time.
Fish	1-lb. fillets 1/4 to 1/2" thick	C	5	5	Handle and turn very carefully. Brush with lemon butter before and during cooking, if desired. Preheat broiler to increase browning.
Ham Slices (precooked)	1" thick	B	8	8	Increase time 5 to 10 minutes per side for 1½" thick or home cured.
Pork Chops Well Done	2 (1/2" thick) 2 (1" thick), about 1 lb.	C B	10 13	10 13	Slash fat.
Lamb Chops Medium Well Done Medium Well Done	2 (1" thick), 10 to 12 oz. 2 (1½" thick), about 1 lb.	C C C B	10 12 14 17	9 10 12 12-14	Slash fat.
Wieners, Sausages, Bratwurst	1-lb. pkg. (10)	C	6	1-2	If desired, split in half lengthwise; cut into 5 to 6" pieces.

What is convection cooking?

In a convection oven, a fan circulates the heated air evenly, over and around the food. This circulating hot air is evenly distributed throughout the oven cavity. As a result, foods are evenly cooked and browned—often in less time with convection heat. Preheating is not necessary with foods having a bake time of over 15 minutes.

- Food is heated faster in a convection oven. When using the convection feature, many types of food can be cooked at lower temperatures than those suggested for regular ovens.
- Recipe books often give times and temperatures for cooking in regular ovens. Convection ovens make it possible to reduce the temperature by 50°F. when using Convection Bake.
- Check foods for doneness at the minimum suggested cooking time.
- Some package instructions for frozen casseroles or main dishes have been developed using commercial convection ovens. For best results in this oven, preheat the oven for 15 minutes and use the temperature on the package.
- Good for multi-shelf baking when baking cookies, brownies, and biscuits.
- Many foods may be cooked using the special Convection Floor Rack in combination with the other oven shelves. Foods such as chocolate chip and sugar cookies, pizza, and pies have shown good results when convection baking using as many as 5 shelves/racks.
- For best results when baking layer cakes, use conventional bake.

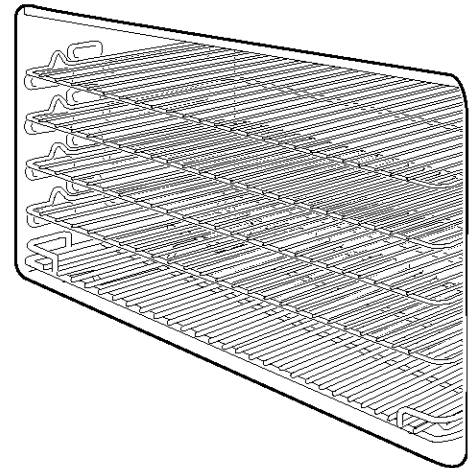
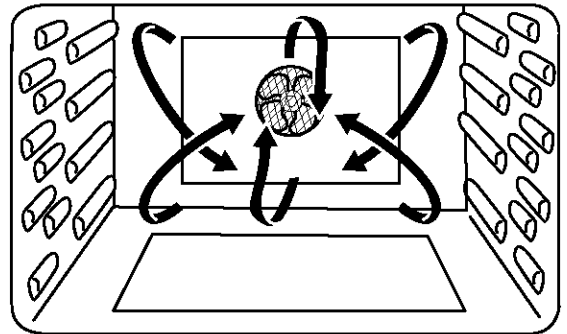

Multi Shelf Convection Cooking

How to set the oven for convection cooking

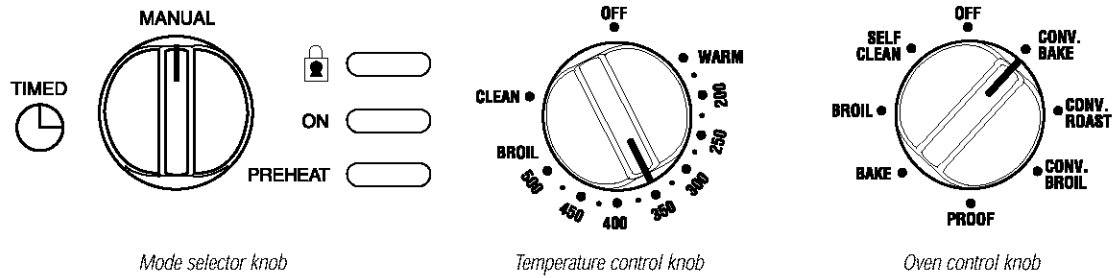

Single oven controls shown set for convection baking.

- 1 Turn the mode selector knob to MANUAL.
- 2 Using the temperature control knob, set the desired temperature.
- 3 Turn the oven control knob to the desired convection setting (CONV. BAKE, CONV. ROAST or CONV. BROIL).

The oven ON light and the oven interior lights turn on and remain on until the oven control knob has been turned to OFF.

- 4 Check the food for doneness at the minimum time on the recipe. Cook longer if necessary.
- 5 Turn the oven control knob to OFF when convection cooking is finished.

Convection Roast

Use for roasting. When set on Convection Roast the outer top element and the bottom element operate whenever heating. Fan operates.

Convection Broil

Use for fish and broiling thick cuts of meat. The door must be closed when Convection Broiling. When set on Convection Broiling both top elements operate whenever heating. Fan operates.

NOTE:

- You will hear a convection fan while cooking with this feature.
- A cooling fan will turn on to cool internal parts. This is normal, and the fan may continue to run even after the oven is turned off.

Convection cookware

Before using your convection oven, check to see if your cookware leaves room for air circulation in the oven. If you are baking with several pans, leave space between them. Also, be sure the pans do not touch each other or the walls of the oven. Use the pan size recommended in the recipe.

When baking cookies, you will get the best results if you use a flat cookie sheet instead of a pan with low sides.

For recipes like oven-baked chicken, you should use a pan with low sides. Hot air cannot circulate well around food in a pan with high sides.

Paper and Plastic

Heat-resistant paper and plastic containers that are recommended for use in regular ovens can be used in convection ovens. Plastic cookware that is heat-resistant to temperatures of 400°F. can also be used.

Metal and Glass

Any type of cookware will work in your convection oven. However, metal pans heat the fastest and are recommended for convection baking.

- Darkened or matte-finished pans will bake faster than shiny pans.
- Glass or ceramic pans cook more slowly.

Convection Roasting Rack

(supplied with product)

Use this rack with the broiler pan and grid to provide good air circulation when convection roasting.

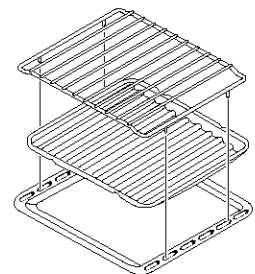

How to set the oven for an immediate start and automatic stop

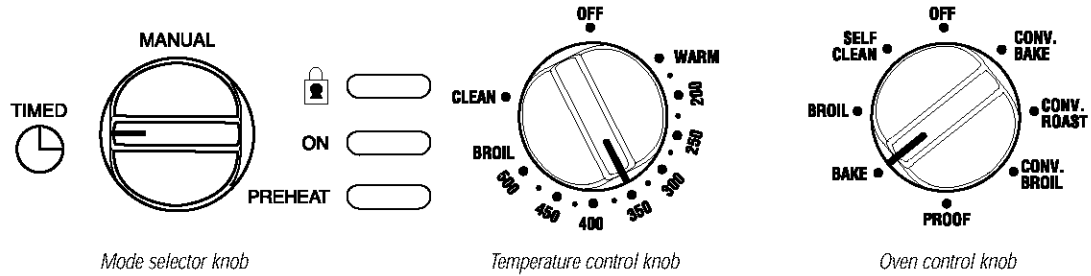

Single oven controls shown set for timed baking.

NOTE: On double oven models, you will not be able to set a timed cooking or cleaning function in both ovens at the same time.

You can set the oven to turn on immediately, cook for a selected length of time and turn off automatically.

NOTE: Before beginning make sure the clock shows the correct time of day.

To avoid possible burns, place the shelves in the correct position before you turn the oven on.

- 1 Turn the mode selector knob to TIMED.
- 2 Turn the oven control knob to the desired function (BAKE, CONV. BAKE or CONV. ROAST).
- 3 Using the temperature control knob, set the desired temperature.

NOTE: The oven ON & PREHEAT lights and the oven interior lights will not turn on until the oven starts heating.

- 4 Press the COOK TIME button.

NOTE: If your recipe requires preheating, you may need to add additional time to the length of cooking time (approximately 15 minutes).

- 5 Press the increase “▲” or decrease “▼” button to set the cooking time. (The maximum cooking time is 11 hours and 50 minutes. The minimum cooking time is 1 minute.)

If the increase “▲” or decrease “▼” button is not pressed within 5 seconds of pressing the COOK TIME button you will need to press COOK TIME again.

The display will show COOK and the cooking time countdown.

The oven will continue to cook for the programmed amount of time then turn off automatically.

- 6 At the end of timed cooking the word COOK will blink in the display and the end of cycle tone will sound. To clear the end of cycle tone press any button. Turn the oven control knobs to OFF and the mode selector knob to MANUAL.

NOTE:

- You will hear a convection fan while cooking with convection features.
- A cooling fan will turn on to cool internal parts. This is normal, and the fan may continue to run even after the oven is turned off.
- The low temperature zone of this oven (between 150°F. and 200°F.) is available to keep hot cooked foods warm. Food kept in the oven longer than two hours at these low temperatures may not be safe to eat.
- Foods that spoil easily, such as milk, eggs, fish, stuffings, poultry and pork, should not be allowed to sit for more than one hour before or after cooking. Room temperature promotes the growth of harmful bacteria. Be sure the oven light is off because heat from the bulb will speed harmful bacteria growth.

How to set the oven for a delayed start and automatic stop

NOTE: On double oven models, you will not be able to set a timed cooking or cleaning function in both ovens at the same time.

You can set the oven to delay the start of cooking, cook for a selected length of time and turn off automatically.

NOTE: Before beginning make sure the clock shows the correct time of day.

To avoid possible burns, place the shelves in the correct position before you turn the oven on.

- 1 Turn the mode selector knob to TIMED.
- 2 Turn the oven control knob to the desired function (BAKE, CONV. BAKE or CONV. ROAST).
- 3 Using the temperature control knob, set the desired temperature.
- 4 Press the START TIME button.
- 5 Press the increase “▲” or decrease “▼” button to set the time of day you want the oven to turn on and start cooking.

If the increase “▲” or decrease “▼” button is not pressed within 5 seconds of pressing the START TIME button you will need to press START TIME again.

- 6 Press the COOK TIME button.
- 7 Press the increase “▲” or decrease “▼” button to set the cooking time. (The maximum cooking time is 11 hours and 50 minutes. The minimum cooking time is 1 minute.)

If the increase “▲” or decrease “▼” button is not pressed within 5 seconds of pressing the COOK TIME button you will need to press COOK TIME again.

NOTE: The oven ON & PREHEAT lights and the oven interior lights will not turn on until the oven starts heating.

The display will return to the time of day and show the word DELAY. When the start time is reached, the display will show the word COOK and the cooking time countdown.

At this time the oven ON light and the oven interior lights turn on and remain on until the end of timed cooking.

The oven will continue to cook for the programmed amount of time then turn off automatically.

- 8 At the end of timed cooking the word COOK will blink in the display and an end of cycle tone will sound. To clear the end of cycle tone press any button. Turn the oven control knob to OFF and the mode selector knob to MANUAL.

NOTE:

- You will hear a convection fan while cooking with convection features.
- A cooling fan will turn on to cool internal parts. This is normal, and the fan may continue to run even after the oven is turned off.
- The low temperature zone of this oven (between 150°F. and 200°F.) is available to keep hot cooked foods warm. Food kept in the oven longer than two hours at these low temperatures may not be safe to eat.
- Foods that spoil easily, such as milk, eggs, fish, stuffings, poultry and pork, should not be allowed to sit for more than one hour before or after cooking. Room temperature promotes the growth of harmful bacteria. Be sure the oven light is off because heat from the bulb will speed harmful bacteria growth.

Adjust the Oven Thermostat

Wall Oven

Do it yourself!

You may feel that your new oven cooks differently than the one it replaced. We recommend that you use your new oven for a few weeks to become more familiar with it, following the times given in your recipes as a guide.

If you think your new oven is too hot or too cool, you can adjust the thermostat yourself. If you think it is too hot, adjust the thermostat to make it cooler. If you think it is too cool, adjust the thermostat to make it hotter.

We do not recommend the use of thermometers, such as those found in grocery stores, to check the temperature setting of your new oven. These thermometers may vary 20–40 degrees.

To adjust the oven thermostat

1. Pull the temperature control knob off the shaft, look at the back of the knob and note the current setting *before* making any adjustments.

2. Loosen both screws on the back of the knob.

3. To **increase** the oven temperature, move the index mark one notch toward the words “**MAKE HOTTER.**”

To **decrease** the oven temperature, move the index mark one notch toward the words “**MAKE COLDER.**”

Each notch changes the temperature by 10 degrees Fahrenheit.

4. Tighten the screws.

5. Replace the knob, matching the flat area of the knob to the shaft.

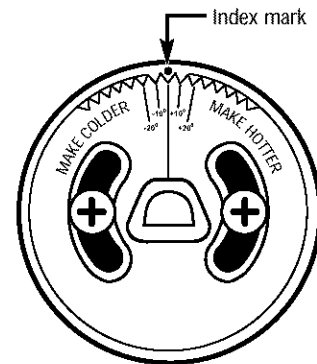

Back of the temperature control knob

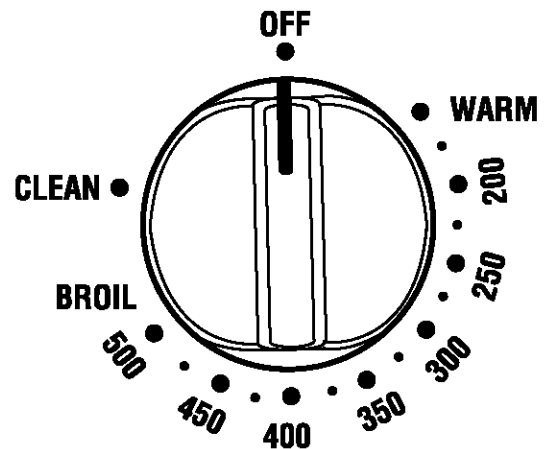

Front of the temperature control knob
(knob appearance may vary)

Self-Cleaning Oven

Wall Oven

Before a clean cycle

The oven must be completely cool in order to set the self-clean cycle.

We recommend venting with an open window or using a ventilation fan or hood during the first self-clean cycle.

Clean soil from the frame around the oven door and outside the door gasket. These areas must be cleaned by hand.

Do not clean the door gasket by hand as this could damage it.

Wipe up excess grease and other food spills with a damp cloth. This will minimize the amount of smoke created during self-cleaning.

Remove all cookware, oven shelves, broiler pan, grid, racks and any aluminum foil from the oven.

Make sure the oven light lens and lens frame are in place.

Do not use commercial oven cleaners or oven protectors in or near the self-cleaning oven.

How to set the oven for cleaning

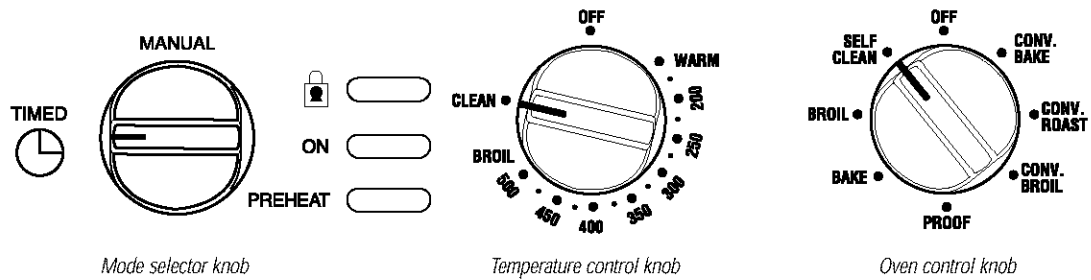

Single oven controls shown set for cleaning.

NOTE: On double oven models, you will not be able to set a timed cooking or cleaning function in both ovens at the same time.

You can set the oven to turn on immediately, clean for a selected length of time and turn off automatically.

NOTE: Before beginning make sure the clock shows the correct time of day.

- 1 Turn the mode selector knob to TIMED.
- 2 Turn the oven control knob to SELF CLEAN.
- 3 Turn the temperature control knob to CLEAN.

Clean time is normally 3 hours. You can change the clean time to any time between 2 and 4 hours depending on the amount of soil in your oven.

If your oven is connected to a 208V electrical supply, we recommend that you set your clean time for 4 hours.

- 4 Press the COOK TIME button if a time other than 3 hours is needed.

- 5 Press the increase "▲" or decrease "▼" button to set the cleaning time.

If the increase "▲" or decrease "▼" button is not pressed within 5 seconds of pressing the COOK TIME button you will need to press COOK TIME again.

The display will show CLEAN and the clean time remaining.

As the oven heats to the clean temperature the door will lock automatically. The locked door, PREHEAT and the oven ON indicator lights turn on.

- 6 After the clean cycle is complete, the oven has cooled and the locked door indicator light is off, turn the oven control knobs to OFF and the mode selector knob to MANUAL.

*How to
delay the
start of
cleaning*

NOTE: On double oven models, you will not be able to set a timed cooking or cleaning function in both ovens at the same time.

You can set the oven to delay the start of cleaning, clean for a selected length of time and turn off automatically.

NOTE: Before beginning make sure the clock shows the correct time of day.

- 1 Turn the mode selector knob to **TIMED**.
- 2 Turn the oven control knob to **SELF CLEAN**.
- 3 Turn the temperature control knob to **CLEAN**.
- 4 Press the **START TIME** button.
- 5 Press the increase “▲” or decrease “▼” button to set the time of day you want the oven to turn on and start cleaning.

If the increase “▲” or decrease “▼” button is not pressed within 5 seconds of pressing the **START TIME** button you will need to press **START TIME** again.

Clean time is normally 3 hours. You can change the clean time to any time between 2 and 4 hours depending on the amount of soil in your oven.

If your oven is connected to a 208V electrical supply, we recommend that you set your clean time for 4 hours.

6 Press the **COOK TIME** button if a time other than 3 hours is needed.

7 Press the increase “▲” or decrease “▼” button to set the cleaning time.

If the increase “▲” or decrease “▼” button is not pressed within 5 seconds of pressing the **COOK TIME** button you will need to press **COOK TIME** again.

The display will return to the time of day and show the word **DELAY**. When the start time is reached, the display will show the word **CLEAN** and the clean time remaining.

As the oven heats to the clean temperature the door will lock automatically. The locked door, **PREHEAT**, and oven **ON** indicator lights turn on.

8 After the clean cycle is complete, the oven has cooled and the locked door indicator light is off, turn the oven control knobs to **OFF** and the mode selector knob to **MANUAL**.

*After a
clean cycle*

If white spots remain, remove them with warm sudsy water and rinse thoroughly with a vinegar and water mixture. These deposits are usually a salt residue that cannot be removed by the clean cycle.

If the oven is not clean after one clean cycle, repeat the cycle.

You may notice some white ash in the oven. Wipe it up with a damp cloth after the oven cools.

Baking Tips

Wall Oven

Oven air flow

IMPORTANT: Internal cooling fan operates during all oven modes. Do not allow this air flow to be obstructed such as by draping kitchen towels over the front of the oven in undercounter applications.

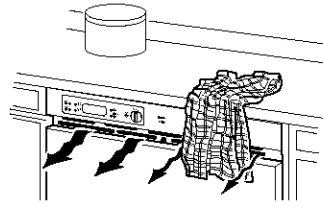

Oven shelves

To avoid possible burns, place the shelves in the correct position before you turn the oven on.

The correct shelf position depends on the kind of food and the browning desired.

The shelves have stop-locks, so that when placed correctly on the supports, they will stop before coming completely out, and will not tilt. When placing and removing cookware, pull the shelf out to the bump on the shelf support.

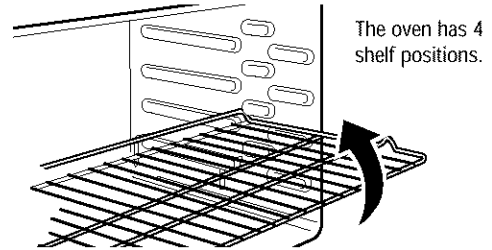

To remove a shelf, pull it toward you, tilt the front end up and pull it out.

To replace, place the end of the shelf (stop-locks) on the support, tilt up the front and push the shelf in.

Convection Floor Rack

To avoid possible burns, always use oven mitts and the Rack Grasp Handles on each side when moving this special rack and **NEVER** pull this rack past the STOP position during cooking. This rack is designed to slide on the oven bottom and extend to stop against the open oven door.

To remove this rack, pull it toward you, tilt the front end up and pull out.

NOTE: This special rack is to be used only in the oven bottom position.

To replace, always be sure the Rack Grasp Handles are toward the front of the oven. Otherwise, foods could slide off the back during extension.

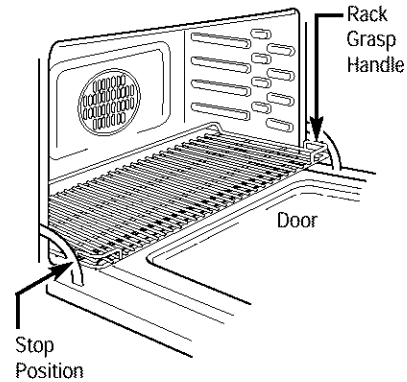

Baking pans/sheets

Use the proper baking pan. The type of finish on the pan determines the amount of browning that will occur.

- Dark, rough or dull pans absorb heat resulting in a browner, crisper crust. Use this type for pies.

- Shiny, bright and smooth pans reflect heat, resulting in a lighter, more delicate browning. Cakes and cookies require this type of pan or sheet.

- Glass baking dishes also absorb heat. When baking in glass baking dishes, the temperature may need to be reduced by 25°F.

Baking Tips

Wall Oven

Pan placement

For even cooking and proper browning, there must be enough room for air circulation in the oven. Baking results will be better if baking pans are centered as much as possible rather than being placed to the front or to the back of the oven.

Pans should not touch each other or the walls of the oven. Allow 1- to 1½-inch space between pans as well as from the back of the oven, the door and the sides.

If you need to use two shelves, use shelf positions A and C and stagger the pans so that one is not directly above the other.

Preheating

Preheat the oven if the recipe calls for it. To preheat, set the oven at the correct temperature— selecting a higher temperature does not shorten preheat time. Preheat the oven for at least 15 minutes, or until the PREHEAT light goes off.

Preheating is necessary for good results when baking cakes, cookies, pastry and breads. Preheat for 15 minutes.

The PREHEAT light will come on and stay on until the oven temperature reaches the pre-set temperature. When the light goes off, foods with recipes requiring a preheated oven should be placed in the oven. This light will CYCLE on and off during the remainder of the cooking process.

Aluminum foil

Never entirely cover a shelf with aluminum foil. This will disturb the heat circulation and result in poor baking. A smaller sheet of foil may be used to catch a spillover by placing it on a lower shelf several inches below the food.

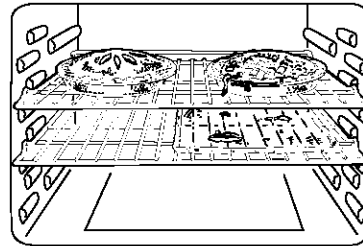

Control panel and knobs

Clean up spatters with a damp cloth. Remove heavier soil with warm, soapy water.

Do not use abrasives of any kind on the control panel.

The control knobs may be removed for easier cleaning. To remove a knob, pull it straight off the stem. Wash the knobs in soap and water but do not soak.

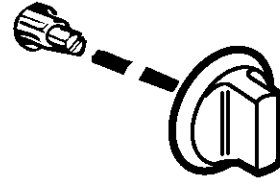

Oven heating elements

Do not clean the broil element. Any soil will burn off when the element is heated.

The bake element is not exposed and is under the oven floor. If spillovers, residue or ash accumulate on the oven floor, wipe up before self-cleaning.

Oven shelves

Clean the shelves with an abrasive cleanser or steel wool. After cleaning, rinse the shelves with clean water and dry with a clean cloth.

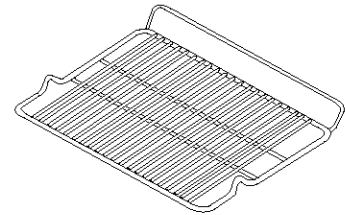

Broiler pan, grid, and Convection Roasting Rack

After broiling, remove the broiler pan and grid from the oven. Remove the grid from the pan. Carefully pour out the grease from the pan into a proper container. Wash and rinse the broiler pan and grid in hot water with a soap-filled or plastic scouring pad.

If food has burned on, sprinkle the grid with detergent while hot and cover with wet paper towels or a dishcloth. Soaking the pan will remove burned-on foods.

The broiler pan and grid may be cleaned with a commercial oven cleaner.

The broiler pan, grid, and Convection Roasting Rack can also be cleaned in the dishwasher.

Do not store a soiled broiler pan, grid, or Convection Roasting Rack anywhere in the oven.

CAUTION: Do not clean the broiler pan, grid, or Convection Roasting Rack in a self-cleaning oven.

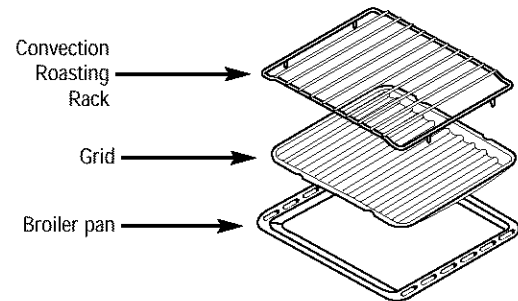

Oven lights

Each oven is equipped with two lights located on the back wall of the oven. The lights come on when the door is opened or when the oven is in a cooking cycle. The oven lights do not come on during self-cleaning.

Each light assembly consists of a removable lens frame, a removable lens, a light bulb and a bulb socket that is fixed in place.

Make sure the oven and lights are cool and power to the oven has been turned off at the main power supply before replacing a light bulb. Failure to do so could result in electrical shock or burns.

To replace a light bulb:

- 1 Remove the lens frame by unscrewing the screw.
- 2 Remove the lens.
- 3 Remove the bulb from its socket.
- 4 Replace the bulb with a new bulb. Be sure to screw the bulb completely into the socket.
- 5 Replace the lens, making sure that it is firmly pressed in place.
- 6 Replace the lens frame and fasten in place with the screw. The lens and lens frame must be in place when using the oven.
- 7 Reconnect electrical power to the oven.

Replacement bulbs may be purchased by calling 800-626-2002.

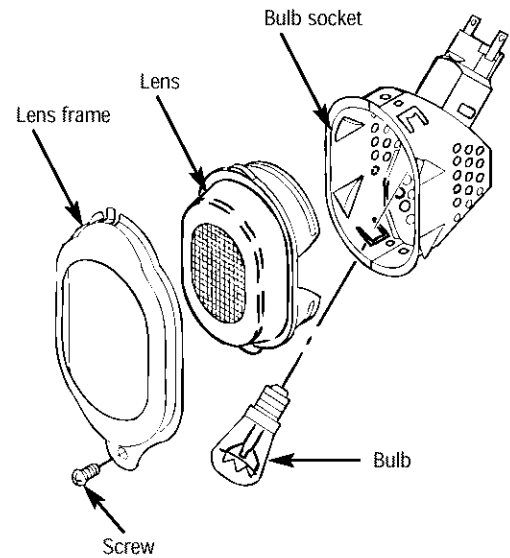

*To clean
the door*

Inside of the door:

- Because the area inside the gasket is cleaned during the self-clean cycle, you do not need to clean this by hand. Any soap left on the liner causes additional stains when the oven is heated so be sure to rinse thoroughly.
- The area outside the gasket can be cleaned with a soap-filled scouring pad.
- **Do not rub or clean the door gasket**—the fiberglass material of the gasket has an extremely low resistance to abrasion. An intact and well-fitting oven door gasket is essential for energy-efficient oven operation and good baking results. If you notice the gasket becoming worn, frayed or damaged in any way or if it has become displaced on the oven, you should have it replaced.

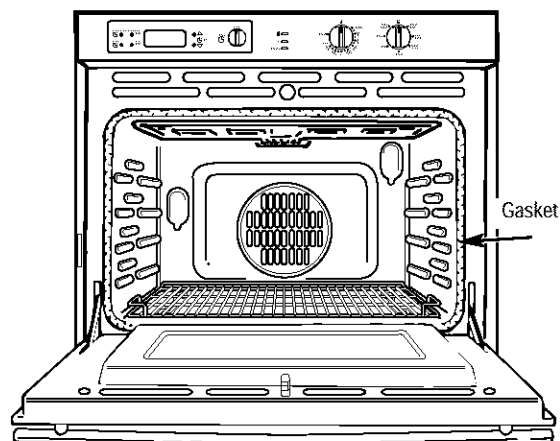

Outside of the door:

Do not use a steel wool pad; it will scratch the surface.

Clean with hot soapy water. Rinse and dry.

If food soil remains, try a general kitchen cleaner, such as Fantastik[®], Simple Green[®] or Formula 409[®].

For hard to clean soil use a standard stainless steel cleaner such as Bon-Ami[®], Cameo[®] or Bar Keepers Friend[®]. Apply cleaner with a damp sponge, rinse thoroughly and dry. Always scrub lightly in the direction of the grain.

After cleaning, use a stainless steel polish such as Stainless Steel Magic[®] (for stainless steel models on stainless steel surfaces only).

To clean the outside of the window, use a glass cleaner. Rinse and polish with a dry cloth.

Do not allow the water or cleanser to run down inside the openings in the glass.

The Problem Solver

Wall Oven

*Questions?
Use this
problem
solver!*

PROBLEM	POSSIBLE CAUSE
OVEN WILL NOT WORK	<ul style="list-style-type: none"> • A fuse in your home may be blown or the circuit breaker tripped. • The oven controls are not properly set. • The oven controls are set for cleaning. If necessary, allow the oven to cool then open the door.
OVEN LIGHT(S) DO NOT WORK	<ul style="list-style-type: none"> • The light bulb is loose or defective. Tighten or replace the bulb. • The oven is self-cleaning or in a "TIMED" delay mode. The oven lights do not come on during self-cleaning or during a "TIMED" delay mode until the oven begins heating.
FOOD DOES NOT BAKE OR ROAST PROPERLY	<ul style="list-style-type: none"> • The oven controls are improperly set. See the "How to set your oven for baking or roasting" section. • Oven not preheated for a long enough time (use at least 15 minutes). • Incorrect cookware or cookware of improper size being used. See the "How to set your oven for baking or roasting" section. • Shelves in the wrong position. See the "How to set the oven for baking or roasting" section. • Use a foil tent to slow down browning during roasting.
FOOD DOES NOT BROIL PROPERLY	<ul style="list-style-type: none"> • The oven controls are not set at BROIL. Turn both the oven control and oven temperature knob to BROIL. • Improper shelf position being used. See the Broiling Guide. • Food is being cooked in a hot pan. • Cookware is not suited for broiling. Use the broiling pan and grid that came with your range. • Aluminum foil used on the broiling pan and grid has not been fitted properly and slit as recommended. • In some areas the power (voltage) may be low. Preheat the broil element for 10 minutes. Broil for the longest period of time recommended in the Broiling Guide.
OVEN WILL NOT SELF CLEAN	<ul style="list-style-type: none"> • The oven temperature is too high to set a self-clean operation. Allow the oven to cool to room temperature and reset the controls. • The controls are not properly set. Be sure the mode selector knob is set in the TIMED position.
"CRACKING" OR "POPPING" SOUND DURING CLEANING	<ul style="list-style-type: none"> • This is normal. This is the sound of the metal heating and cooling during both the cooking and cleaning functions.
EXCESSIVE SMOKING OCCURS DURING CLEANING	<ul style="list-style-type: none"> • Excessive soil. Turn the oven control knobs to OFF. Open the windows to rid the room of smoke. Wait until the locked door indicator light goes off. Wipe up excess soil and reset the clean cycle.
OVEN NOT CLEAN AFTER A CLEAN CYCLE	<ul style="list-style-type: none"> • The oven was heavily soiled. Clean up heavy spillovers before starting the clean cycle. Heavily soiled ovens may need to self-clean again. • Oven is connected to a 208V electrical supply. Set your cleaning time for 4 hours. • The oven controls are not properly set. Be sure the mode selector knob is set in the TIMED position. See the "Self-Cleaning" section.

If you need more help...call, toll free:
GE Answer Center®
800.626.2000
consumer information service

With the purchase of your new Monogram appliance, receive the assurance that if you ever need information or assistance from GE, we'll be there. All you have to do is call—toll-free!

GE Answer Center®

800.626.2000

Whatever your question about any Monogram major appliance, GE Answer Center® information service is available to help. Your call—and your question—will be answered promptly and courteously. And you can call any time. GE Answer Center® service is open 24 hours a day, 7 days a week.

In-Home Repair Service

800-444-1845

A GE consumer service professional will provide expert repair service, scheduled at a time that's convenient for you. Many GE Consumer Service company-operated locations offer you service today or tomorrow, or at your convenience (7:00 a.m. to 7:00 p.m. weekdays, 9:00 a.m. to 2:00 p.m. Saturdays). Our factory-trained technicians know your appliance inside and out—so most repairs can be handled in just one visit.

For Customers With Special Needs...

800.626.2000

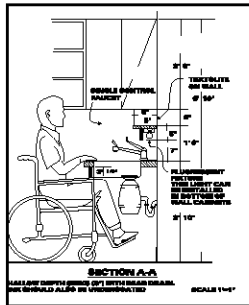

GE offers, free of charge, a brochure to assist in planning a barrier-free kitchen for persons with limited mobility.

Consumers with impaired hearing or speech who have access to a TDD or a conventional teletypewriter may call 800-TDD-GEAC (800-833-4322) to request information or service.

Service Contracts

800-626-2224

You can have the secure feeling that GE Consumer Service will still be there after your warranty expires. Purchase a GE contract while your warranty is still in effect and you'll receive a substantial discount. With a multiple-year contract, you're assured of future service at today's prices.

Parts and Accessories

800-626-2002

Individuals qualified to service their own appliances can have parts or accessories sent directly to their home. The GE parts system provides access to over 47,000 parts...and all GE Genuine Renewal Parts are fully warranted. VISA, MasterCard and Discover cards are accepted.

User maintenance instructions contained in this guide cover procedures intended to be performed by any user. Other servicing generally should be referred to qualified service personnel. Caution must be exercised, since improper servicing may cause unsafe operation.

YOUR MONOGRAM WALL OVEN WARRANTY
Staple sales slip or cancelled check here. Proof of original purchase date is needed to obtain service under warranty.

WHAT IS COVERED

FULL ONE-YEAR WARRANTY

For one year from date of original purchase, we will provide, free of charge, parts and service labor in your home to repair or replace **any part of the oven** that fails because of a manufacturing defect.

.....

This warranty is extended to the original purchaser and any succeeding owner for products purchased for ordinary home use in the 48 mainland states, Hawaii and Washington, D.C. In Alaska the warranty is the same except that it is LIMITED because you must pay to ship the product to the service shop or for the service technician's travel costs to your home.

All warranty service will be provided by our Factory Service Centers or by our authorized Customer Care® servicers during normal working hours.

Should your appliance need service, during warranty period or beyond, call 800-444-1845.

WHAT IS NOT COVERED

· Service trips to your home to teach you how to use the product.

Read your Use and Care material.

If you then have any questions about operating the product, please contact your dealer or our Consumer Affairs office at the address below, or call, toll free:

GE Answer Center®
800.626.2000
consumer information service

· Replacement of house fuses or resetting of circuit breakers.

· Damage to the product caused by accident, fire, floods or acts of God.

· Failure of the product if it is used for other than its intended purpose or used commercially.

· Improper installation.

If you have an installation problem, contact your dealer or installer. You are responsible for providing adequate electrical, gas, exhausting and other connecting facilities as described in the Installation Instructions provided with the product.

WARRANTOR IS NOT RESPONSIBLE FOR CONSEQUENTIAL DAMAGES.

Some states do not allow the exclusion or limitation of incidental or consequential damages, so the above limitation or exclusion may not apply to you. This warranty gives you specific legal rights, and you may also have other rights which vary from state to state.

To know what your legal rights are in your state, consult your local or state consumer affairs office or your state's Attorney General.

Warrantor: General Electric Company. If further help is needed concerning this warranty, write: Manager—Consumer Affairs, GE Appliances, Louisville, KY 40225

**Consumer Product
Ownership Registration**
Important Mail Today

GE Appliances



Place
1st Class
Letter
Stamp
Here

General Electric Company
Warranty Registration Department
P.O. Box 34070
Louisville, KY 40232-4070

Consumer Product Ownership Registration

Dear Customer:

Thank you for purchasing our product and thank you for placing your confidence in us. We are proud to have you as a customer!

Follow these three steps to protect your new appliance investment:

1 Complete and mail your separate Consumer Product Ownership Registration today. Have the peace of mind of knowing we can contact you in the unlikely event of a safety modification.

2 After completing the registration, write your model and serial numbers in this guide. You will need this information should you require service. Our service number is 800-444-1845.

3 Read your "Use and Care Guide" carefully. It will help you operate your new appliance properly. If you have questions, or need more information call the GE Answer Center® 800.626.2000.

Important: To ensure that your product is registered, mail the separate product registration card. If the separate product registration card is missing, fold and mail the form below. No envelope is needed.

FOLD HERE

Consumer Product Ownership Registration



Product
Wall Oven

Model

Serial

Mr. Ms. Mrs. Miss

First Name _____ Last Name _____

Street Address _____

Apt. # _____

City _____ State _____ Zip Code _____

Date Placed In Use _____ Day _____ Year _____ Phone Number _____ - _____ - _____



TAPE CLOSED



Monogram™

General Electric Company
Louisville, KY 40225

Part No. 164D3333P201
Pub No. 49-8974

5-99 JR

Printed in Italy