

Monogram®

Use and Care Guide

for Bottom Mount  
Built-In  
Refrigerators

*Introduction*

Your new Monogram refrigerator makes an eloquent statement of style, convenience and kitchen planning flexibility. Whether you chose it for its purity of design, practical storage arrangements or assiduous attention to detail—or for all of these reasons—you’ll find that your Monogram refrigerator’s superior blend of form and function will delight you for years to come.

The Monogram refrigerator was designed to provide the flexibility to blend in with your kitchen cabinetry. Decorative door insert panels allow it to match your kitchen cabinets or blend with your kitchen decor. Custom handles are also available to further personalize your refrigerator. Through a series of product and trim kit choices, the Monogram refrigerator can be beautifully integrated into the kitchen.

Since this is designed to be a built-in product, custom panels are required on the front of the Monogram refrigerator. Consult your kitchen designer or cabinetmaker for your customized look.

The information on the following pages will help you operate and maintain your refrigerator properly.

If you have any other questions—in the USA, please call the GE Answer Center® 800.626.2000. In Canada, please call 1.888.880.3030.

*Contents*

**Consumer Services**

Important Phone Numbers .....	20
Model and Serial Numbers .....	3
Problem Solver .....	16, 17
Product Registration .....	3, 22
Safety Instructions .....	4-7
Warranty for Customers in Canada .....	23
Warranty for Customers in the USA ..	Back Cover

**Care and Cleaning**

Cleaning—Outside and Inside .....	13
Condenser .....	13
Light Bulb Replacement .....	14
Vacation .....	14

**Operating Instructions**

Automatic Icemaker .....	9
Shelves .....	11, 12
Storage Drawers .....	10
Temperature Controls .....	8
Water Filter Accessory .....	9

**Preparation**

Clearances .....	15
Leveling .....	15
Location .....	15

*Before using your refrigerator*

Read this guide carefully. It is intended to help you operate and maintain your new refrigerator properly.

Keep it handy for answers to your questions.

If you don't understand something or need more help, call in the USA:

**GE Answer Center®**

**800.626.2000**

**24 hours a day, 7 days a week**

**In Canada, call 1.888.880.3030.**

---

*Write  
down the  
model &  
serial  
numbers*

You'll see them on a label inside the fresh food compartment under the storage drawers.

These numbers are also on the Consumer Product Ownership Registration Card included with this guide.

**Before sending in this card, please write these numbers here:**

---

Model Number

---

Serial Number

Use these numbers in any correspondence or service calls concerning your refrigerator.

---

*If you received  
a damaged  
refrigerator*

Immediately contact the dealer (or builder) that sold you the refrigerator.

---

*Save time  
& money*

Before you request service, check the Problem Solver in the back of this guide.

It lists causes of minor operating problems that you can correct yourself.

---

*If you  
need  
service*

To obtain service, see the Consumer Services page in the back of this guide.

We're proud of our service and want you to be pleased. If for some reason you are not happy with the service you receive, here are steps to follow for further help.

***For customers in the USA:***

FIRST, contact the people who serviced your appliance. Explain why you are not pleased. In most cases, this will solve the problem.

NEXT, if you are still not pleased, write all the details—including your phone number—to:

Manager, Customer Relations  
GE Appliances  
Appliance Park  
Louisville, KY 40225

***For customers in Canada:***

FIRST, contact the people who serviced your appliance. Explain why you are not pleased. In most cases, this will solve the problem.

NEXT, if you are still not pleased, write all the details—including your phone number to:

Manager, Consumer Relations  
Camco Inc.  
1 Factory Lane, Suite 310  
Moncton, N.B. E1C 9M3

# IMPORTANT SAFETY INSTRUCTIONS

---

## *READ AND SAVE THESE INSTRUCTIONS*

**WARNING**—When using this appliance, always exercise basic safety precautions, including the following:

- **Use this appliance only for its intended purpose** as described in this Use and Care Guide.
- **This refrigerator must be properly installed in accordance with the Installation Instructions before it is used.**
- **Do not allow children to climb, stand or hang on the shelves in the refrigerator.** They could damage the refrigerator and seriously injure themselves.
- **Do not touch the cold surfaces in the freezer compartment when hands are damp or wet.** Skin may adhere to these extremely cold surfaces.
- **Do not store or use gasoline or other flammable vapors and liquids in the vicinity of this or any other appliance.**
- **If your refrigerator has an automatic icemaker,** avoid contact with the moving parts of the ejector mechanism, or with the heating element that releases the cubes. Do not place fingers or hands on the automatic icemaking mechanism while the refrigerator is plugged in.
- **Unplug your refrigerator before cleaning and making repairs.** **NOTE:** We strongly recommend that any servicing be performed by a qualified individual.
- **Before replacing a burned-out light bulb,** the refrigerator should be unplugged in order to avoid contact with a live wire filament. (A burned-out light bulb may break when being replaced.) **NOTE:** Turning control to OFF does not remove power to the light circuit.
- **Do not refreeze frozen foods which have thawed completely.**

---

## **▲ DANGER: RISK OF CHILD ENTRAPMENT**

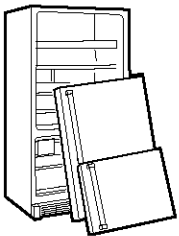

Child entrapment and suffocation are not problems of the past. Junked or abandoned refrigerators are still dangerous...even if they will sit for "just a few days." If you are getting rid of your old refrigerator, please follow the instructions below to help prevent accidents.

### **Before You Throw Away Your Old Refrigerator or Freezer:**

- Take off the doors.
- Leave the shelves in place so that children may not easily climb inside.

---

## *CFC DISPOSAL*

Your old refrigerator has a cooling system that used CFCs (chlorofluorocarbons). CFCs are believed to harm stratospheric ozone.

If you are throwing away your old refrigerator, make sure the CFC refrigerant is removed for proper disposal by a qualified servicer. If you intentionally release this CFC refrigerant you can be subject to fines and imprisonment under provisions of environmental legislation.

---

## LIRE ET CONSERVER CES INSTRUCTIONS

**AVERTISSEMENT :** Lorsque vous utilisez le réfrigérateur, observez toujours certaines précautions de base, notamment :

- **N'utilisez le réfrigérateur que pour son usage prévu**, comme décrit dans le présent guide.
- **Installez le réfrigérateur conformément aux directives d'installation avant de l'utiliser.**
- **Ne laissez pas les enfants grimper, s'asseoir, se tenir debout ni se pendre aux clayettes du réfrigérateur.** Ils pourraient endommager le réfrigérateur et se blesser gravement.
- **Une fois le réfrigérateur en marche, ne touchez pas les surfaces froides du congélateur, surtout si vous avez les mains humides ou mouillées :** la peau risque d'adhérer à ces surfaces très froides.
- **N'entreposez et n'utilisez pas d'essence ou autres vapeurs et liquides inflammables à proximité de cet appareil ou de tout autre appareil électroménager.**

- **Si votre réfrigérateur est doté d'une machine à glaçons automatique**, évitez le contact avec les pièces mobiles du mécanisme éjecteur, ou avec l'élément chauffant qui libère les glaçons. Ne posez pas les doigts ou les mains sur le mécanisme de la machine à glaçons pendant que le réfrigérateur est branché.
- **Débranchez votre réfrigérateur avant de le nettoyer et de le réparer.**  
**REMARQUE :** Nous vous recommandons vivement de confier toute réparation à un technicien qualifié.
- **Avant de remplacer une ampoule grillée**, le réfrigérateur doit être débranché afin d'éviter tout contact avec un fil sous tension. (Une ampoule grillée peut se briser pendant l'opération). **REMARQUE :** Lorsque vous placez la commande sur «0» (éteint), l'alimentation électrique de l'ampoule n'est pas coupée.
- **Ne faites PAS recongeler des aliments surgelés qui ont complètement dégelé.**

---

## ⚠ DANGER : RISQUES POUR LES ENFANTS

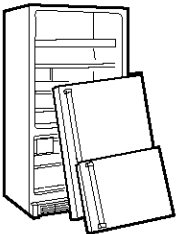

Les enfants pris au piège ou morts d'asphyxie sont toujours d'actualité. Les appareils de réfrigération abandonnés sont toujours aussi dangereux, même si on n'attend que "quelques jours" pour s'en débarrasser. Si vous ne gardez pas votre ancien appareil, veuillez suivre les directives ci-dessous afin de prévenir les accidents.

**Avant de vous débarrasser de votre vieux appareil de réfrigération :**

- Démontez les portes.
- Laissez les clayettes en place afin d'empêcher les enfants de grimper à l'intérieur.

---

## SE DÉBARRASSER DU CFC

Les vieux appareils de réfrigération ont un système de refroidissement qui a utilisé les CFC (chlorofluorocarbones). Les CFCs sont jugés nocifs pour l'ozone stratosphérique.

Si vous débarrassez de votre vieil appareil de réfrigération, assurez-vous que le frigorigène avec CFC soit enlevé correctement par un technicien qualifié. Si vous libérez intentionnellement ce frigorigène avec CFC vous pouvez être soumis aux contraventions et à l'emprisonnement après les stipulations des lois sur l'environnement.

# IMPORTANT SAFETY INSTRUCTIONS

---

## *HOW TO CONNECT ELECTRICITY*

**Do not, under any circumstances, cut or remove the third (ground) prong from the power cord. For personal safety, this appliance must be properly grounded.**

The power cord of this appliance is equipped with a 3-prong (grounding) plug which mates with a standard 3-prong (grounding) wall outlet to minimize the possibility of electric shock hazard from this appliance.

Have the wall outlet and circuit checked by a qualified electrician to make sure the outlet is properly grounded.

Where a standard 2-prong wall outlet is encountered, it is your personal responsibility and obligation to have it replaced with a properly grounded 3-prong wall outlet.

The refrigerator should always be plugged into its own individual electrical outlet which has a voltage rating that matches the rating plate.

**DO NOT USE AN ADAPTER PLUG TO CONNECT THE REFRIGERATOR TO A 2-PRONG OUTLET.**

**DO NOT USE AN EXTENSION CORD WITH THIS APPLIANCE.**

This provides the best performance and also prevents overloading house wiring circuits which could cause a fire hazard from overheated wires.

Never unplug your refrigerator by pulling on the power cord. Always grip plug firmly and pull straight out from the outlet.

Repair or replace immediately all power cords that have become frayed or otherwise damaged. Do not use a cord that shows cracks or abrasion damage along its length or at either end.

When moving the refrigerator away from the wall, be careful not to roll over or damage the power cord.

## SAVE THESE INSTRUCTIONS

---

## RACCORDEMENT ÉLECTRIQUE

**Ne coupez ni retirez en aucun cas la troisième broche (mise à la terre) de la fiche du cordon d'alimentation. Pour votre sécurité, cet appareil doit être correctement mis à la terre.**

Le cordon d'alimentation de cet appareil est muni d'une fiche à 3 broches (mise à la terre) qui se branche dans une prise mural ordinaire à 3 alvéoles (mise à la terre) pour réduire au minimum les risques du chocs électriques.

Faites examiner la prise de courant et le circuit par un électricien qualifié pour vous assurer que la prise est correctement mise à la terre.

Si la prise murale est du type standard à 2 alvéoles, il vous incombe de la faire remplacer par une prise à 3 alvéoles correctement mise à la terre.

La machine à glaçons doit toujours être branché dans sa propre prise de courant, dont la tension nominale est identique à celle indiquée sur la plaque signalétique.

**N'UTILISEZ PAS UNE FICHE D'ADAPTATION POUR RACCORDER LE RÉFRIGÉRATEUR DANS UNE PRISE MURALE À 2 ALVÉOLES.**

**N'UTILISEZ PAS DE CORDONS PROLONGATEURS AVEC CET APPAREIL.**

Cette précaution est recommandée pour garantir un rendement optimum et éviter une surcharge des circuits électriques de la résidence, ce qui pourrait créer un risque d'incendie par surschauffe des fils.

Ne débranchez jamais l'appareil en tirant le cordon d'alimentation. Saisissez fermement la fiche du cordon et tirez droit pour la retirer de la prise.

Réparez ou remplacez immédiatement tout cordon effiloché ou endommagé. N'utilisez pas un cordon fendillé ou présentant des signes d'usure.

Lorsque vous déplacez l'appareil du mur, faites attention de ne pas la faire rouler sur le cordon d'alimentation afin de ne pas l'endommager.

## CONSERVEZ CES DIRECTIVES

### *Set the temperature controls*

Your refrigerator has two controls that let you regulate the temperature in the fresh food and freezer compartments.

They have settings from 1 through 9, and are located at the top of the fresh food compartment.

The freezer control also has an OFF setting.

9 is the coldest setting, 1 is the warmest.

**WHEN YOU FIRST TURN THE REFRIGERATOR ON, SET BOTH CONTROLS AT 5.**

For colder or warmer temperatures, adjust the desired compartment control one number at a time.

**IMPORTANT: When first setting controls, or adjusting them, allow 24 hours for the refrigerator to get cold.**

**NOTE: Turning the freezer control to the OFF position stops cooling in BOTH compartments— fresh food AND freezer— but does not shut off power to the refrigerator.**



### *How to test temperatures*

**Use the milk test for the fresh food compartment.** Place a container of milk on the top shelf in the fresh food compartment. Check it a day later. If the milk is too warm or too cold, adjust the temperature controls.

**Use the ice cream test for the freezer compartment.** Place a container of ice cream in the center of the freezer compartment. Check it after a day. If it's too hard or too soft, adjust the temperature controls.

**Always allow 24 hours for the refrigerator to reach the temperature you set.**

### *Energy saver switch*

The energy saver switch is located on the temperature control panel.

**To reduce the amount of electricity required to operate your refrigerator, push switch to ENERGY SAVER setting.**

This turns off the heater in your refrigerator that prevents moisture from forming on the outside of the refrigerator.

With the heater turned off, there is a chance that moisture may form on the outside of your refrigerator, especially when the weather is humid.

The humidity is most likely to be high in the summer, in the early morning hours, and in homes which are not air conditioned.

Over an extended period of time, moisture that forms on the refrigerator surface may cause deterioration of the paint finish. It will be important to protect the finish by using appliance polish wax as described in the Care and Cleaning section.

**Move the energy saver switch from the ENERGY SAVER setting** and electricity flows through the low wattage heater which warms the outside of the refrigerator. Under most conditions, this prevents the forming of moisture or water droplets.



*Automatic icemaker*

A newly-installed refrigerator may take 8 to 12 hours to begin making ice.

The icemaker will produce eight cubes per cycle—approximately 100 cubes in a 24-hour period, depending on freezer compartment temperature, room temperature, number of door openings and other use conditions.

**If your refrigerator is operated before the water connection is made to the icemaker, keep the feeler arm in the STOP (up) position.**

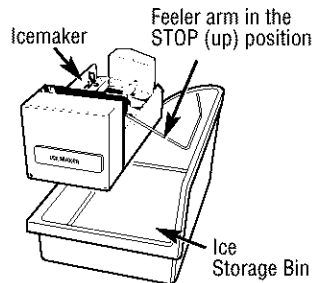

**When the refrigerator has been connected to the water supply, move the feeler arm to the ON (down) position.**

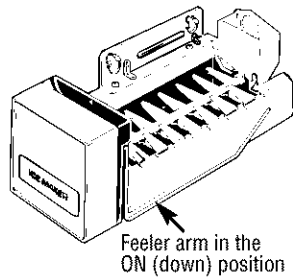

The icemaker will fill with water when it cools to freezing. A newly-installed refrigerator may take 8 to 12 hours to begin making ice cubes.

Throw away the first few batches of ice. This flushes away impurities in the water line.

Icemaking will continue until the feeler arm senses enough ice cubes in the storage bin. For maximum ice production, level the stored cubes with your hand occasionally. Be sure nothing interferes with the swing of the feeler arm.

The icemaker ejects cubes in groups of eight and it is normal for several cubes to be joined together.

**Move the icemaker feeler arm to the STOP (up) position when:**

- home water supply is to be off for several hours.
- ice storage bin is to be removed for a period of time.
- going away on vacation, at which time you should also turn off the valve in the water supply line to your refrigerator.
- turning the freezer control to the OFF position.

**If ice is not used frequently, old ice cubes will become cloudy and taste stale.** Empty the ice storage bin periodically and wash it in lukewarm water. Be sure to allow the storage bin to dry before replacing it—otherwise ice cubes may stick to other parts of the icemaker.

**If this is your first icemaker, you'll hear occasional sounds that may be unfamiliar.** They are normal icemaking sounds and are not a cause for concern.

*Water filter accessory*

The water filter is an option at extra cost and is available from your dealer. Specify WR97X0214. It has complete installation instructions and installs on 1/4" O.D. copper water line.



## Storage Drawers

*Bottom Mount Refrigerator*

### *Storage drawers*

These drawers have individual, adjustable humidity controls that let you control the amount of cold air entering the drawers.

**Slide the control all the way to the High setting** and the drawer provides **higher humidity levels** recommended for most leafy vegetables.

**Slide the control all the way to the Low setting** and the drawer provides **lower humidity levels** recommended for most fruits.

Excess water that may accumulate in the bottom of the drawers should be emptied and the drawers wiped dry.

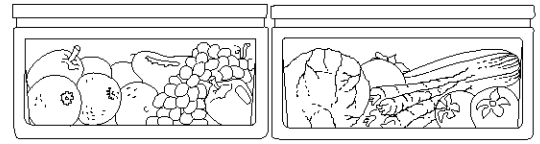

### *Sealed snack pans*

The sealed snack pans retain high humidity for the convenient storage of lunch meats and cheese, hors d'oeuvres, spreads and snacks.

**To remove a snack pan**, pull the pan out and lift the front of the pan up until it snaps out of the wire holder.

**To replace a snack pan**, place the back of the pan in the wire holder. Lower the front of the pan, then push down until the front of the pan snaps into the wire holder.

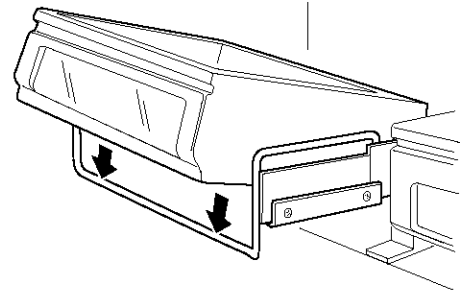
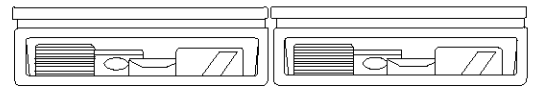

### *Drawer removal*

Drawers in the fresh food compartment will stop before coming all the way out of the refrigerator, to help prevent contents from spilling onto floor.

**To remove a drawer**, pull the drawer out and lift the front of the drawer up and out of the wire holder. Lift the back of the drawer up and out.

**To remove the drawers when the refrigerator door cannot be opened fully**, the shelf above the drawers must be removed. Push the shelf back then lift up. Tilt the cover and take it out.

**To replace a drawer**, place the back of the drawer in the wire holder, making sure the extensions of the side of the drawer fit into the back of the wire holder. Lower the front of the drawer into the wire holder. Press firmly on the top of the drawer.

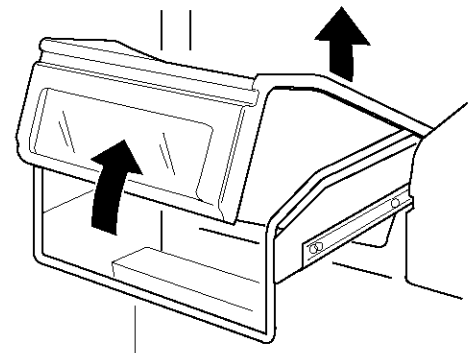

### *Adjustable shelves in the fresh food compartment*

Tempered glass shelves in the fresh food compartment enable you to make efficient shelf arrangements to fit your family's food storage needs.

**To remove shelves:** Tilt shelf up at front, then lift it up and out of tracks on rear wall of refrigerator.

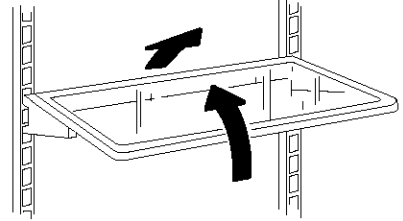

**To replace shelves:** Select desired shelf height. With shelf front raised slightly, engage top lugs in tracks at rear of cabinet. Then lower front of shelf until it locks into position.

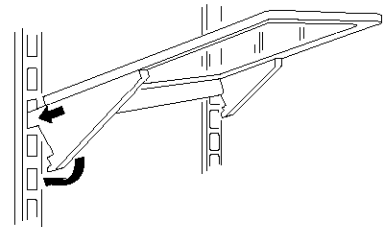

### *Removable wine rack (on some models)*

The wine rack is designed to hold a bottle on its side and will fit on any shelf.

**To relocate the wine rack:** Pull the wine rack straight out, position its lip over the right edge of the shelf you want to suspend it from and push it all the way in.

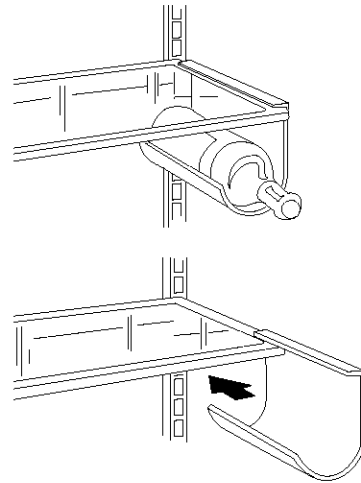

### *Door shelves*

Some door shelves are adjustable and can be moved up and down to meet your storage needs. The deeper door shelves must be placed at the bottom of the door.

**To remove:** Lift the shelf up and slide it towards you.

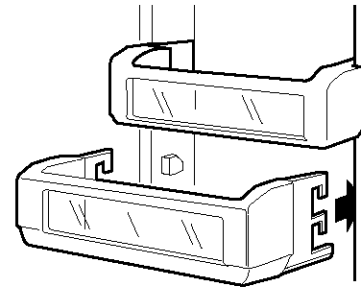

### *Freezer drawer with basket*

Inside the freezer drawer is a wire slide-out freezer basket.

This basket can be pushed back so items on the bottom of the freezer drawer can be reached.

**To remove the basket:** Pull the drawer forward. Lift the front of the basket up and then take it out.

When replacing basket make sure the wheels are on the track.

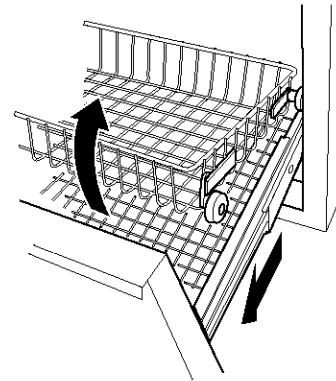

### Cleaning outside

**The door handles and trim** can be cleaned with a cloth dampened with a solution of mild liquid dishwashing detergent and water. Dry with a soft cloth. Don't use wax on the door handles or trim.

**The stainless steel panels and door handles** (on some models) can be cleaned with a commercially available stainless steel cleaner such as *Stainless Steel Magic*.

*Stainless Steel Magic* is available at Ace, True Value, Servistar, HWI and other leading stores. It is also available through GE Parts by calling 1-800-626-2000. Order part number WX10X15.

Do not use appliance wax or polish on the stainless steel.

### Cleaning inside

**To help prevent odors**, leave an open box of baking soda in the fresh food and freezer compartments.



**Unplug the refrigerator before cleaning.** If this is not practical, wring excess moisture out of sponge or cloth when cleaning around switches, lights or controls.

Use warm water and baking soda solution—about a tablespoon (15 ml) of baking soda to a quart (1 l) of water. This both cleans and neutralizes odors. Rinse and wipe dry.

**Other parts of the refrigerator**—including door gaskets, meat and vegetable drawers, ice storage bin and all plastic parts—can be cleaned the same way. After cleaning the door gaskets, apply a thin layer of petroleum jelly to the door gaskets at the hinge side. This helps keep the gaskets from sticking and bending out of shape.

**Avoid cleaning cold glass shelves with hot water because the extreme temperature difference may cause them to break. Handle glass shelves carefully. Bumping tempered glass can cause it to shatter.**

**Do not wash any plastic refrigerator parts in the dishwasher.**

### Condenser

#### To clean the condenser fins:

First turn off the power at the circuit breaker or fuse box. Wait about 30 minutes for the condenser area to cool. Then remove the decorative panel by lifting up and toward you.

Use a soft bristle brush to loosen dust and lint on the condenser fins. Use a vacuum hose to remove soil.

**After cleaning:** Reconnect power at the fuse box or circuit breaker.

**Replace the decorative panel.**

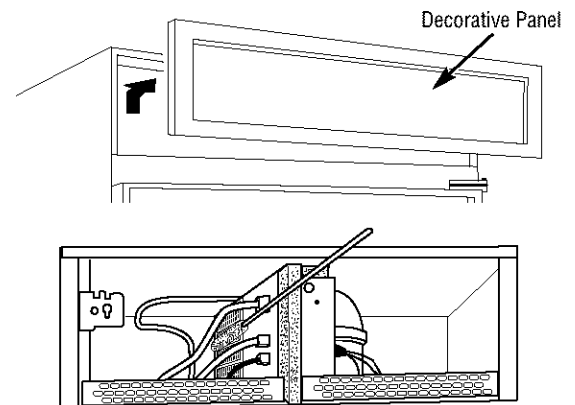

### *Preparing for vacation*

For long vacations or absences, remove food and unplug the refrigerator. Move the control to OFF, and clean the interior with a baking soda solution of one tablespoon (15 ml) of baking soda to one quart (1 l) of water. Leave the doors open.

**For shorter vacations**, remove perishable foods and leave controls at regular settings. However, if the room temperature is expected to drop below 60°F (16°C), follow the same instructions as for extended vacations.

Move the icemaker feeler arm to the STOP (up) position and shut off the water supply to the refrigerator.

### *Light bulb replacement in the fresh food compartment*

**Turning the control to OFF does not remove power to the light circuit.**

There are two light bulbs in the top of the fresh food compartment.

**To replace a bulb:**

- 1 Turn off power at the circuit breaker or fuse box.
- 2 Remove the light shield by lifting up the front end of the light shield and tilting the back down. Then slide the light shield out the opening in the back.
- 3 Replace with the same size bulb and reinstall the shield.

**NOTE:** When reinstalling the shield it is important that the notched edge of the shield is towards the front.

- 4 Turn the power on.

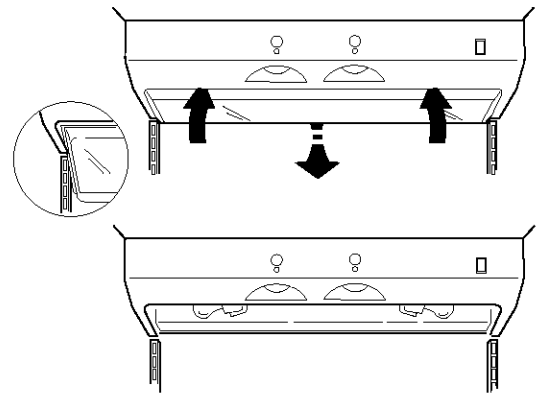

### *Light bulb replacement in the freezer compartment*

**To replace a bulb:**

- 1 Turn off power at the circuit breaker or fuse box.
- 2 Remove the freezer light shield by removing the two screws with a Phillips screwdriver.
- 3 Replace with the same size bulb, reinstall the shield, and turn the power on.

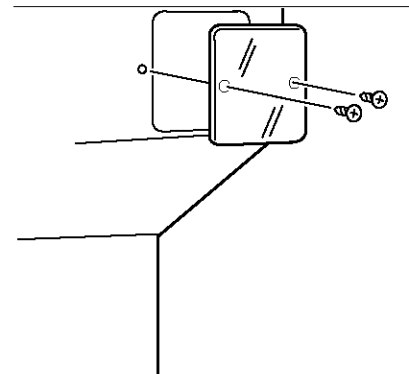

## Preparation

### *Bottom Mount Refrigerator*

#### *Refrigerator location*

**Do not install refrigerator where temperature will be below 60°F (16°C) because it will not run often enough to maintain proper temperatures.**

**Do install it on a floor strong enough to support a fully loaded refrigerator.**

#### *Clearances*

If the refrigerator is to be installed in a corner, allow 2" (51 mm) between the hinges of the refrigerator and the wall to assure a 90° door opening capability.

No other clearances at top, sides or back are required.

#### *Leveling*

This model has 4-point leveling. All 4 corners are supported by leveling legs. The front wheels are non-adjustable; they are only used for positioning the unit.

- To level the back of the unit, turn hex nut located above the front wheels.
- To level the front of the unit, use a 1 1/4" open end wrench and adjust the leveling legs.
- Turn hex nut or front leveling leg clockwise to raise the unit, counter-clockwise to lower the unit.

See the Installation Instructions (Pub. No. 49-6983) for complete directions.

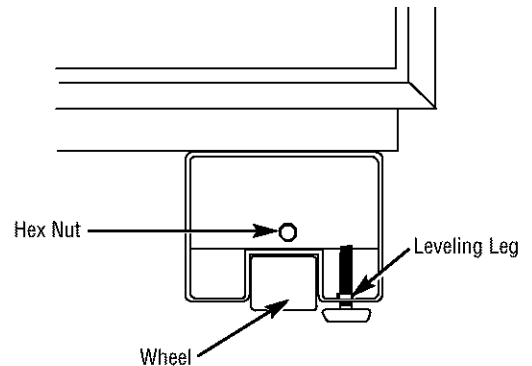

*Questions?  
Use this  
problem  
solver!*

<b>PROBLEM</b>	<b>POSSIBLE CAUSE</b>
<b>REFRIGERATOR DOES NOT OPERATE</b>	<ul style="list-style-type: none"> <li>· May be in defrost cycle when motor does not operate for about 30 minutes.</li> <li>· Temperature control in the OFF position.</li> <li>· If interior light is not on, refrigerator may not be plugged in at wall outlet.</li> <li>· The fuse is blown/circuit breaker is tripped. Replace fuse or reset the breaker.</li> </ul>
<b>MOTOR OPERATES FOR LONG PERIODS OR CYCLES ON AND OFF FREQUENTLY (Modern refrigerators with more storage space and a larger freezer require more operating time. They start and stop often to maintain even temperatures.)</b>	<ul style="list-style-type: none"> <li>· Normal when refrigerator is first plugged in. Wait 24 hours for the refrigerator to completely cool down.</li> <li>· Often occurs when large amounts of food are placed in refrigerator. This is normal.</li> <li>· Door left open or package holding door open.</li> <li>· Hot weather or frequent door openings. This is normal.</li> <li>· Temperature controls set at the coldest setting. See Temperature Controls.</li> <li>· Condenser needs cleaning. See Care and Cleaning.</li> </ul>
<b>VIBRATION OR RATTLING (Slight vibration is normal.)</b>	<ul style="list-style-type: none"> <li>· See Leveling.</li> </ul>
<b>OPERATING SOUNDS</b>	<ul style="list-style-type: none"> <li>· The high speed compressor motor required to maintain near zero temperatures in the large freezer compartment may produce higher sound levels than your old refrigerator.</li> <li>· Normal fan air flow—one fan blows cold air through the refrigerator and freezer compartments—another fan cools the compressor motor.</li> <li>· These NORMAL sounds will also be heard from time to time:               <ul style="list-style-type: none"> <li>· Defrost timer switch clicks at defrost.</li> <li>· Defrost water dripping.</li> <li>· Temperature control clicks ON or OFF.</li> <li>· Refrigerant boiling or gurgling.</li> <li>· Cracking or popping of cooling coils caused by expansion and contraction during defrost and refrigeration following defrost.</li> <li>· Ice cubes dropping into the bin and water running in pipes as icemaker refills.</li> </ul> </li> </ul>
<b>DOOR NOT CLOSING PROPERLY</b>	<ul style="list-style-type: none"> <li>· Refrigerator not level. See Leveling.</li> </ul>
<b>FRESH FOOD OR FREEZER COMPARTMENT TOO WARM</b>	<ul style="list-style-type: none"> <li>· Temperature controls not set cold enough. See Temperature Controls.</li> <li>· Warm weather or frequent door openings.</li> <li>· Door left open for long time.</li> <li>· Package may be holding door open.</li> </ul>



*Questions?*  
*Use this*  
*problem*  
*solver!*

<b>PROBLEM</b>	<b>POSSIBLE CAUSE</b>
<b>FROST OR ICE CRYSTALS ON FROZEN FOOD</b> (Frost within package is normal.)	<ul style="list-style-type: none"> <li>· Door left open or package holding door open.</li> <li>· Too frequent or too long door openings.</li> </ul>
<b>SLOW ICE CUBE FREEZING</b>	<ul style="list-style-type: none"> <li>· Door may have been left open.</li> <li>· Turn temperature of freezer compartment colder.</li> </ul>
<b>ICE CUBES HAVE ODOR/TASTE</b>	<ul style="list-style-type: none"> <li>· Old cubes need to be discarded.</li> <li>· Ice storage bin needs to be emptied and washed.</li> <li>· Unsealed packages in refrigerator and/or freezer compartments may be transmitting odor/taste to ice cubes.</li> <li>· Interior of refrigerator needs cleaning. See Care and Cleaning.</li> <li>· Poor-tasting incoming water. Install a water filter.</li> </ul>
<b>AUTOMATIC ICEMAKER DOES NOT WORK</b>	<ul style="list-style-type: none"> <li>· Icemaker feeler arm in STOP (up) position.</li> <li>· Water supply turned off or not connected.</li> <li>· Freezer compartment too warm.</li> <li>· Piled up cubes in storage bin may cause icemaker to shut off too soon. With icemaker feeler arm in STOP (up) position, level cubes in bin.</li> </ul>
<b>MOISTURE FORMS ON OUTSIDE OF REFRIGERATOR</b>	<ul style="list-style-type: none"> <li>· Not unusual during periods of high humidity. Wipe surface dry.</li> </ul>
<b>MOISTURE COLLECTS INSIDE</b>	<ul style="list-style-type: none"> <li>· Too frequent or too long door openings.</li> <li>· In humid weather, air carries moisture into refrigerator when doors are opened.</li> </ul>
<b>REFRIGERATOR HAS ODOR</b>	<ul style="list-style-type: none"> <li>· Foods with strong odors should be tightly covered.</li> <li>· Check for spoiled food.</li> <li>· Interior needs cleaning. See Care and Cleaning.</li> <li>· Defrost water system needs cleaning.</li> <li>· Keep open box of baking soda in refrigerator; replace every 3 months.</li> </ul>
<b>INTERIOR LIGHT DOES NOT WORK</b>	<ul style="list-style-type: none"> <li>· No power at outlet.</li> <li>· Light bulb needs replacing. See Care and Cleaning.</li> </ul>







**Consumer Product  
Ownership Registration  
Important Mail Today**

***GE Appliances***



Place  
1st Class  
Letter  
Stamp  
Here

***General Electric Company***  
**Warranty Registration Department**  
**P.O. Box 32150**  
**Louisville, KY 40232-2150**

# Consumer Product Ownership Registration

Dear Customer:

Thank you for purchasing our product and thank you for placing your confidence in us. We are proud to have you as a customer!

Follow these three steps to protect your new appliance investment:



**1** Complete and mail your Consumer Product Ownership Registration today. Have the peace of mind of knowing we can contact you in the unlikely event of a safety modification.

**2** After completing this registration, write your model and serial numbers in this guide. You will need this information should you require service. The service number in the USA: 800.444.1845. In Canada: 1.888.880.3030.

**3** Read your "Use and Care Guide" carefully. It will help you operate your new appliance properly. If you have questions, or need more information in the USA, call the **GE Answer Center®** 800.626.2000. In Canada call 1.888.880.3030

**Important:** To ensure that your product is registered, mail the separate product registration card. If the separate product registration card is missing, fold and mail the form below. No envelope is needed.

FOLD HERE

## Consumer Product Ownership Registration

Important  
Mail  
Today!

Product  
Refrigerator

Model

Serial

Mr.  Ms.  Mrs.  Miss

First Name \_\_\_\_\_ Last Name \_\_\_\_\_

Street Address \_\_\_\_\_

Apt. # \_\_\_\_\_

City \_\_\_\_\_ State \_\_\_\_\_ Zip Code \_\_\_\_\_

Date Placed  
In Use Month \_\_\_\_\_ Day \_\_\_\_\_ Year \_\_\_\_\_ Phone Number \_\_\_\_\_ - \_\_\_\_\_ - \_\_\_\_\_



TAPE CLOSED

**YOUR MONOGRAM REFRIGERATOR WARRANTY**

**Staple sales slip or cancelled check here. Proof of original purchase date is needed to obtain service under warranty.**

**WHAT IS COVERED**

*From the Date of the Original Purchase*

**FULL TWO-YEAR WARRANTY**

For two years from date of original purchase, we will provide, free of charge, parts and service labor in your home to repair or replace *any part of the refrigerator* that fails because of a manufacturing defect.

**FULL FIVE-YEAR WARRANTY**

For five years from date of original purchase, we will provide, free of charge, parts and service labor in your home to repair or replace *any part of the sealed refrigerating system* (the compressor, condenser, evaporator and all connecting tubing) that fails because of a manufacturing defect.

**LIMITED ADDITIONAL SEVEN-YEAR WARRANTY ON THE SEALED SYSTEM**

For the sixth through twelfth year from the date of the original purchase, we will provide, free of charge, replacement parts for *any part of the sealed refrigerating system* (the compressor, condenser, evaporator and all connecting tubing) that fails because of a manufacturing defect. You pay for the service trip to your home and for service labor charges.



This warranty is extended to the original purchaser and any succeeding owner for products purchased for ordinary home use in Canada.

All warranty service will be provided by our Factory Service Centers or by our authorized Customer Care® servicers during normal working hours.

Should your appliance need service, during warranty period or beyond, call 1.888.880.3030.

**WHAT IS NOT COVERED**

· Service trips to your home to teach you how to use the product.

**Read your Use and Care material.**

If you then have any questions about operating the product, please contact your dealer or our Consumer Relations office at the address below, or call, toll free:

**1.888.880.3030**

· Replacement of house fuses or resetting of circuit breakers.

· Damage to the product caused by accident, fire, floods or acts of God.

· Failure of the product if it is used for other than its intended purpose or used commercially.

· Improper installation.

If you have an installation problem, contact your dealer or installer. You are responsible for providing adequate electrical, plumbing and other connecting facilities.

**WARRANTOR IS NOT RESPONSIBLE FOR CONSEQUENTIAL DAMAGES.**

Some provinces do not allow the exclusion or limitation of incidental or consequential damages, so the above limitation or exclusion may not apply to you. This warranty gives you specific legal rights, and you may also have other rights which vary from province to province. To know what your legal rights are in your province, consult your local or provincial consumer affairs office.

**Warrantor: Camco Inc. If further help is needed concerning this warranty, write: Manager, Consumer Relations, Camco Inc., 1 Factory Lane, Suite 310, Moncton, N.B. E1C 9M3.**

**YOUR MONOGRAM REFRIGERATOR WARRANTY**

**Staple sales slip or cancelled check here. Proof of original purchase date is needed to obtain service under warranty.**

**WHAT IS COVERED**

*From the Date of the Original Purchase*

**FULL TWO-YEAR WARRANTY**

For two years from date of original purchase, we will provide, free of charge, parts and service labor in your home to repair or replace *any part of the refrigerator* that fails because of a manufacturing defect.

**FULL FIVE-YEAR WARRANTY**

For five years from date of original purchase, we will provide, free of charge, parts and service labor in your home to repair or replace *any part of the sealed refrigerating system* (the compressor, condenser, evaporator and all connecting tubing) that fails because of a manufacturing defect.

**LIMITED ADDITIONAL SEVEN-YEAR WARRANTY ON THE SEALED SYSTEM**

For the sixth through twelfth year from the date of the original purchase, we will provide, free of charge, replacement parts for *any part of the sealed refrigerating system* (the compressor, condenser, evaporator and all connecting tubing) that fails because of a manufacturing defect. You pay for the service trip to your home and for service labor charges.

.....

This warranty is extended to the original purchaser and any succeeding owner for products purchased for ordinary home use in the 48 mainland states, Hawaii and Washington, D.C. In Alaska the warranty is the same except that it is LIMITED because you must pay to ship the product to the service shop or for the service technician's travel costs to your home.

All warranty service will be provided by our Factory Service Centers or by our authorized Customer Care® servicers during normal working hours.

Should your appliance need service, during warranty period or beyond, in the U.S.A call 800.444.1845. In Canada: 888.880.3030.

**WHAT IS NOT COVERED**

• Service trips to your home to teach you how to use the product.

**Read your Use and Care material.**

If you then have any questions about operating the product, please contact your dealer or our Customer Relations office at the address below, or call, toll free:

**GE Answer Center®**  
**800.626.2000**  
**consumer information service**

• Replacement of house fuses or resetting of circuit breakers.

• Damage to the product caused by accident, fire, floods or acts of God.

• Failure of the product if it is used for other than its intended purpose or used commercially.

• Improper installation.

If you have an installation problem, contact your dealer or installer. You are responsible for providing adequate electrical, plumbing and other connecting facilities.

• Loss of food due to spoilage.

**WARRANTOR IS NOT RESPONSIBLE FOR CONSEQUENTIAL DAMAGES.**

Some states do not allow the exclusion or limitation of incidental or consequential damages, so the above limitation or exclusion may not apply to you. This warranty gives you specific legal rights, and you may also have other rights which vary from state to state. To know what your legal rights are in your state, consult your local or state consumer affairs office or your state's Attorney General.

**Warrantor: General Electric Company. If further help is needed concerning this warranty, write: Manager—Customer Relations, GE Appliances, Louisville, KY 40225**

95021-01

Part No. 162D9632P002

Pub No. 49-60057-1

1-00 JR

Printed in the United States

