

# PRO-FORM 320x

Model No. 831.293032

Serial No. \_\_\_\_\_

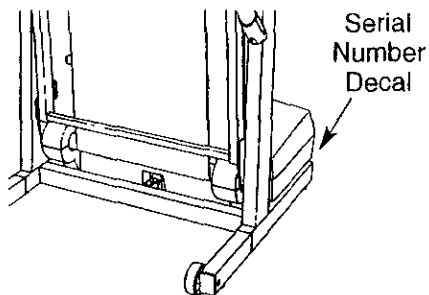

## USER'S MANUAL

EXERCISE  
EQUIPMENT

QUESTIONS

HELPLINE!

1-800-736-6879

Sears, Roebuck and Co.  
Hoffman Estates, IL 60179

### CAUTION

Read all precautions and instructions in this manual before using this equipment. Save this manual for future reference.

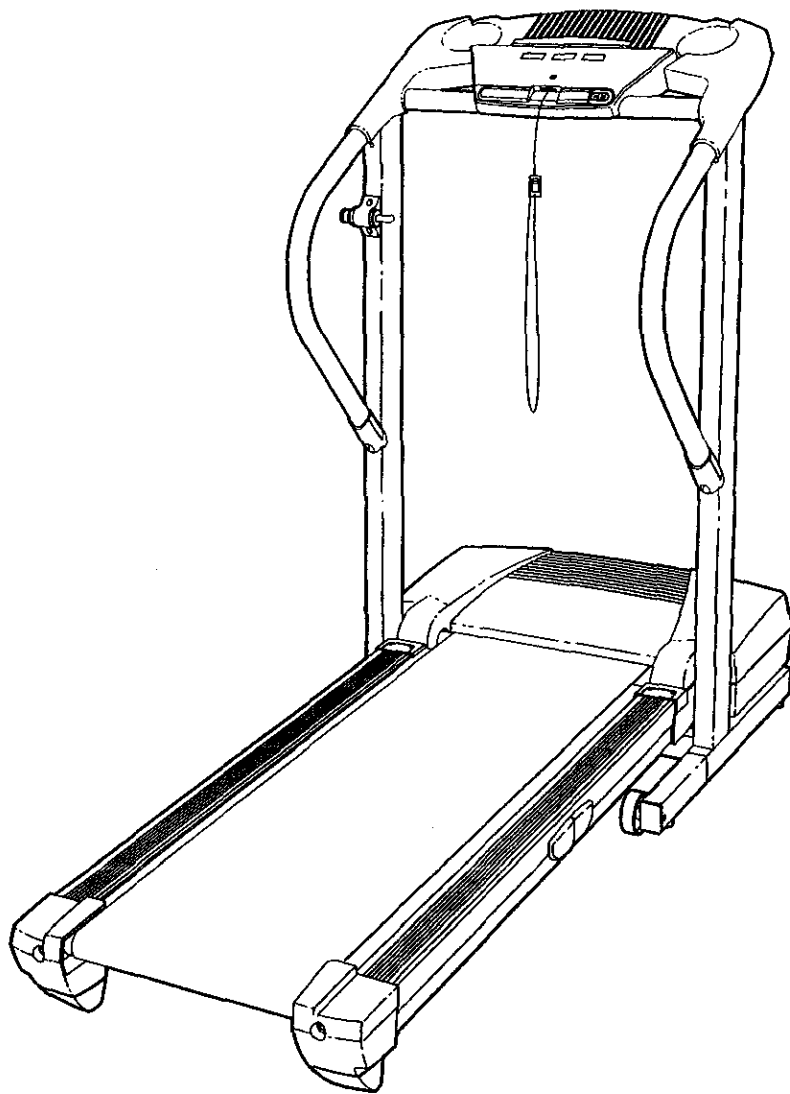

Visit our website at

[www.proform.com](http://www.proform.com)

*new products, prizes,  
fitness tips, and much more!*

# TABLE OF CONTENTS

IMPORTANT PRECAUTIONS	.....
BEFORE YOU BEGIN	.....
ASSEMBLY	.....
OPERATION AND ADJUSTMENT	.....
HOW TO FOLD AND MOVE THE TREADMILL	.....
TROUBLESHOOTING	.....
CONDITIONING GUIDELINES	.....
ORDERING REPLACEMENT PARTS	..... Back Cov
FULL 90 DAY WARRANTY	..... Back Cov

Note An EXPLODED DRAWING and a PART LIST are attached in the center of this manual.

## IMPORTANT PRECAUTIONS

**▲ WARNING:** To reduce the risk of burns, fire, electric shock, or injury to persons, read the following important precautions and information before operating the treadmill.

1. It is the responsibility of the owner to ensure that all users of this treadmill are adequately informed of all warnings and precautions.
2. Use the treadmill only as described.
3. Place the treadmill on a level surface, with at least eight feet of clearance behind it and two feet on each side. Do not place the treadmill on any surface that blocks air openings. To protect the floor or carpet from damage, place a mat under the treadmill.
4. Keep the treadmill indoors, away from moisture and dust. Do not put the treadmill in a garage or covered patio, or near water.
5. Do not operate the treadmill where aerosol products are used or where oxygen is being administered.
6. Keep children under the age of 12 and pets away from the treadmill at all times.  
The treadmill should be used only by persons weighing 250 pounds or less.
8. Never allow more than one person on the treadmill at a time.
9. Wear appropriate exercise clothes when using the treadmill. Do not wear loose clothes that could become caught in the treadmill. Athletic support clothes are recommended for both men and women. Always wear athletic shoes. Never use the treadmill with bare feet, wearing only stockings, or in sandals.
10. When connecting the power cord (see page 6), plug the power cord into a surge suppressor (not included) and plug the surge suppressor into a grounded circuit capable of carrying 15 or more amps. No other appliance should be on the same circuit. Do not use an extension cord.
11. Use only a single-outlet surge suppressor that meets all of the specifications described on page 8. To purchase a surge suppressor, see your local SEARS or call 1-800-366-7278 and order part number 146148.
12. Failure to use a properly functioning surge suppressor could result in damage to the control system of the treadmill. If the control system is damaged, the walking belt may change speed or stop unexpectedly, which may result in a fall and serious injury.
13. Keep the power cord and the surge suppressor away from heated surfaces.
14. Never move the walking belt while the power is turned off. Do not operate the treadmill if the power cord or plug is damaged, or if the treadmill is not working properly. (See BEFORE YOU BEGIN on page 4 if the treadmill is not working properly.)
15. Never start the treadmill while you are standing on the walking belt. Always hold the handrails or upper body arms while using the treadmill.

16. The treadmill is capable of high speeds. Adjust the speed in small increments to avoid sudden jumps in speed.
17. Never leave the treadmill unattended while it is running. Always remove the key and unplug the power cord when the treadmill is not in use.
18. Do not attempt to raise, lower, or move the treadmill until it is properly assembled. (See ASSEMBLY on page 5, and HOW TO FOLD AND MOVE THE TREADMILL on page 11.) You must be able to safely lift 45 pounds (20 kg) to raise, lower, or move the treadmill.
19. When folding or moving the treadmill, make sure that the storage latch is fully closed.

20. Inspect and properly tighten all parts of the treadmill regularly.
21. Never insert any object into any opening.
22. **DANGER:** Always unplug the power cord immediately after use, before cleaning the treadmill, and before performing the maintenance and adjustment procedures described in this manual. Never remove the motor hood unless instructed to do so by an authorized service representative. Servicing other than the procedures in this manual should be performed by an authorized service representative only.
23. This treadmill is intended for in-home use only. Do not use this treadmill in a commercial, rental, or institutional setting.

**⚠ WARNING:** Before beginning this or any exercise program, consult your physician. This is especially important for persons over the age of 35 or persons with pre-existing health problems. Read all instructions before using. SEARS assumes no responsibility for personal injury or property damage sustained by or through the use of this product.

## SAVE THESE INSTRUCTIONS

The decals shown have been placed on your treadmill. If a decal is missing, or if it is not legible, please call our toll-free HELPLINE to order a free replacement decal (see the front cover of this manual). Apply the decal in the location shown. Note: The decals are not shown at actual size.

**⚠ WARNING:**  
The key does not disconnect the power. To prevent possible injury, turn off power switch and unplug treadmill when not in use.

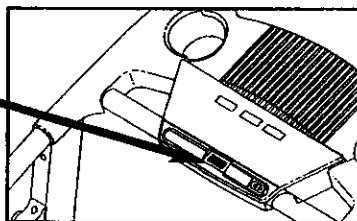

**⚠ WARNING:**  
• Hazardous Voltage  
• Risk of Electric Shock  
• Unplug Treadmill before Assembly/Disassembly.

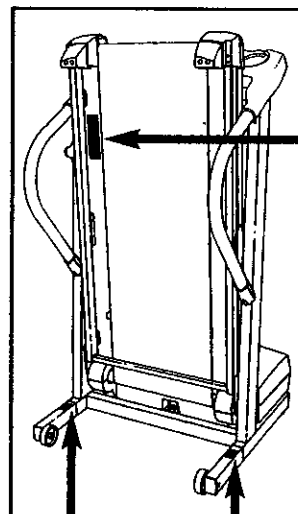
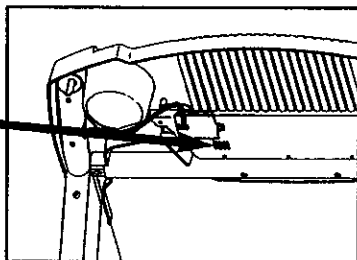

**⚠ CAUTION**  
KEEP HANDS AND FEET AWAY FROM THIS AREA WHILE THE TREADMILL IS IN OPERATION.

**⚠ WARNING:**  
Protect yourself and others from risk of serious injury. Read the user's manual and:

- Stand only on the side rails when starting or stopping treadmill.
- Change speed in small increments.
- Hold handrails to prevent falling, and always wear the safety clip while operating treadmill.
- Stop if you feel faint, dizzy, or short of breath.
- Fully engage storage latch before treadmill is moved or stored.
- Reduce incline to its lowest level before folding treadmill into storage position.

• Never allow children on or around treadmill.

• Remove key when not in use.

• Keep clothing, fingers, and hair away from moving belt.

• Never try to adjust or fix the belt while it is moving.

• Always wear athletic shoes while operating treadmill.

# BEFORE YOU BEGIN

Thank you for selecting the revolutionary PROFORM® 320x treadmill. The 320x treadmill combines advanced technology with innovative design to help you get the most from your exercise program in the convenience and privacy of your home. And when you're not exercising, the unique 320x treadmill can be folded up, requiring less than half the floor space of other treadmills.

**For your benefit, read this manual carefully before using the treadmill.** If you have additional questions, please call our toll-free HELPLINE at 1-800-736-6879,

Monday through Saturday, 7 a.m. until 7 p.m. Central Time (excluding holidays). To help us assist you, please note the product model number and serial number before calling. The model number of the treadmill is 831.293032. The serial number can be found on a decal attached to the treadmill (see the front cover of this manual for the location).

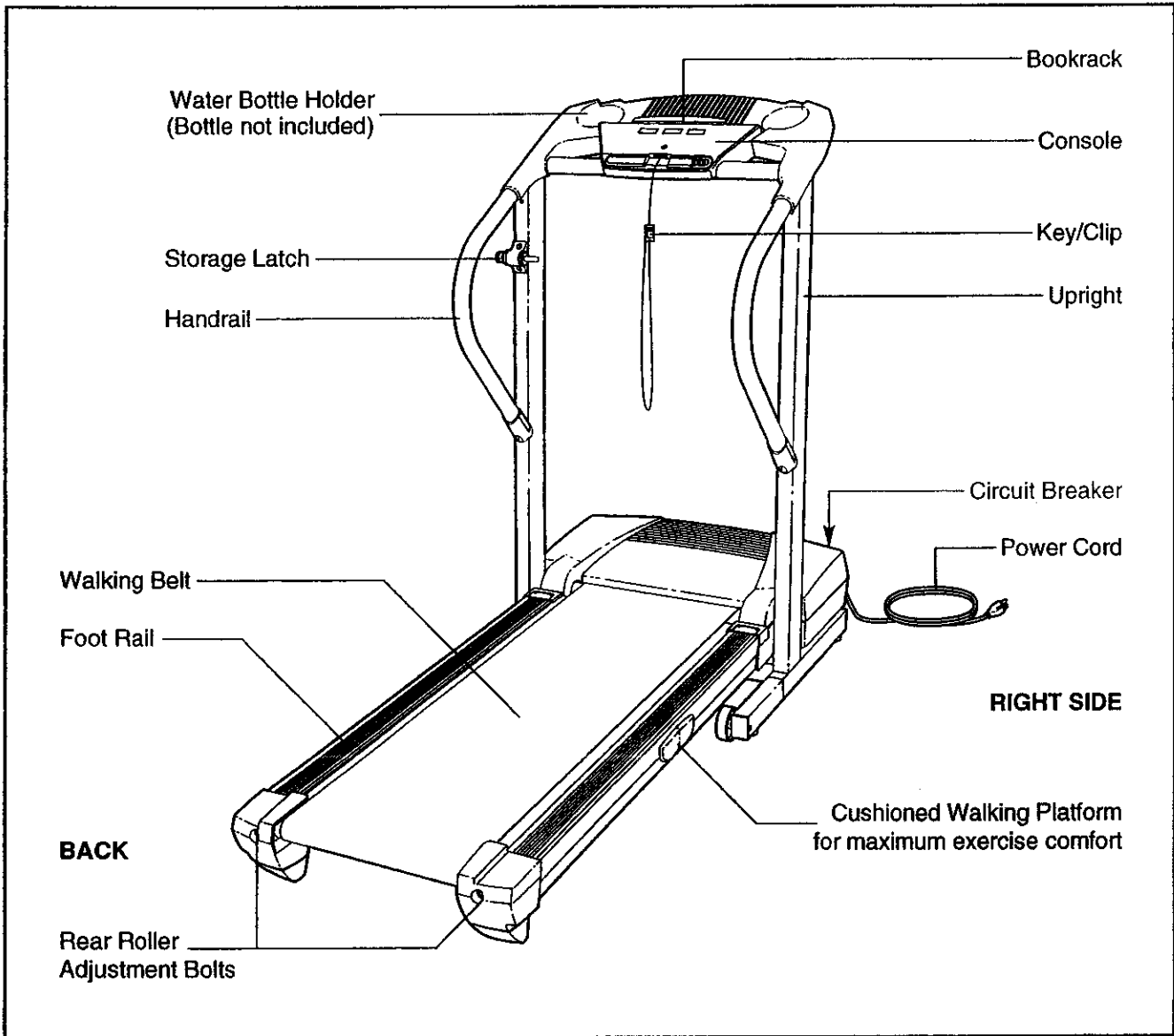

Before reading further, please review the drawing below and familiarize yourself with the labeled parts.



# ASSEMBLY

**Assembly requires two persons.** Set the treadmill in a cleared area and remove all packing materials. Do not dispose of the packing materials until assembly is completed.

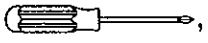
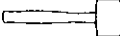
Note: The underside of the treadmill walking belt is coated with high-performance lubricant. During shipping, a small amount of lubricant may be transferred to the top of the walking belt or the shipping carton. This is a normal condition and does not affect treadmill performance. If there is lubricant on top of the walking belt, simply wipe off the lubricant with a soft cloth and a mild, non-abrasive cleaner.

Assembly requires the included allen wrenches  and your own phillips screwdriver , rubber mallet , wire cutters , and needlenose pliers .

To identify small parts, use the PART IDENTIFICATION CHART attached in the center of this manual.

## 1. Make sure that the power cord is unplugged.

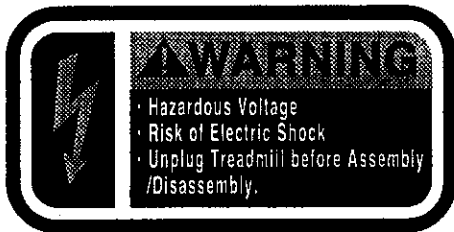

With the help of a second person, carefully raise the Uprights (69) until the treadmill is in the position shown. Insert one of the Extension Legs (63) into the treadmill as shown. (Note: It may be helpful to tip the Uprights as you insert the Extension Leg.) Make sure that the Warning Decal (62) is on the indicated side of the Extension Leg.

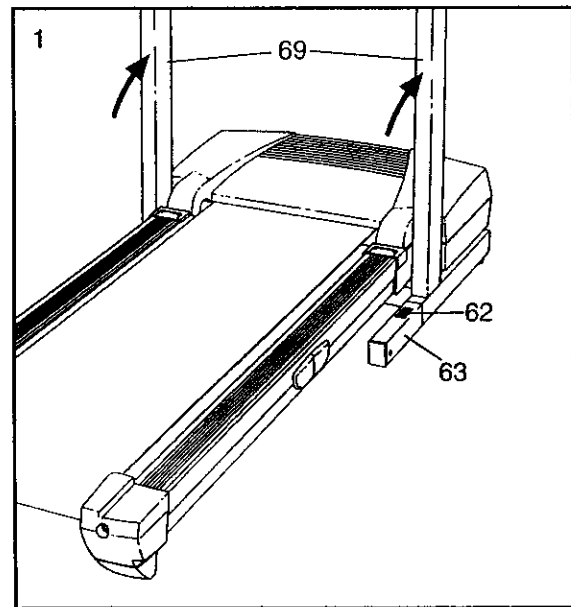

Insert the other Extension Leg (63) in the same way.

## 2. With the help of a second person, carefully lower the treadmill frame and then tip the Uprights (69) down as shown. (Note: It may be helpful to place your foot on an Extension Leg [63] as you tip the Uprights.) **Make sure that the Extension Legs remain in the Uprights.**

Attach each Extension Leg (63) with two 3/4" Tek Screws (58).

Attach four Base Pads (57) with 3/4" Tek Screws (58) as shown.

Note: One replacement Base Pad (57) may be included. If a Base Pad becomes worn and needs to be replaced, use the replacement Base Pad.

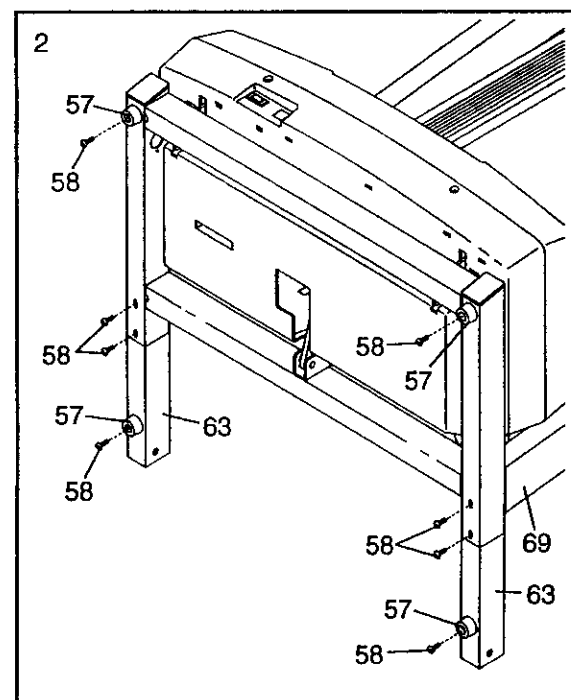

- With the help of a second person, raise the Uprights (69) to the vertical Position. Attach the Storage Latch (36) to the left Upright with two 3/4" Screws (2). Remove the Lock Knob (30) from the Lock Pin (35). Make sure that the Lock Pin Collar (33) and the Spring (32) are on the Lock Pin as shown. Insert the Lock Pin into the Storage Latch and tighten the Lock Knob back onto the Lock Pin.

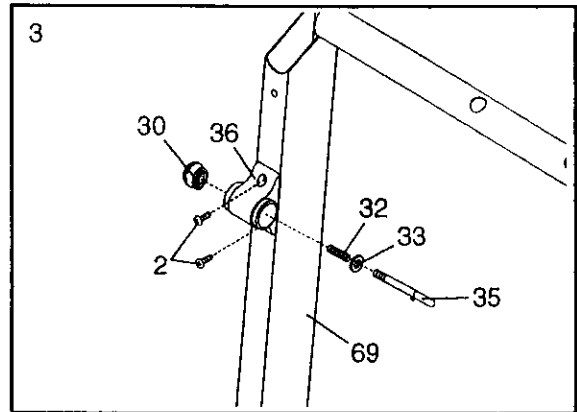

- Identify the Right Handrail (72), which has a large hole in the left side. Feed the Wire Harness (42) up into the bracket on the Right Handrail and out of the large hole in the left side. (Note: It may be helpful to use needlenose pliers to pull the Wire Harness out of the large hole.) Press a Handrail Cap (76) onto the lower end of the Right Handrail as shown.

Insert the bracket on the Right Handrail (72) into the top of the right Upright (69) so the Handrail Cap (76) is resting against the Upright. Attach the Right Handrail and the Handrail Cap with **three 1" Bolts (37) and two Washers (38) as shown. Firmly tighten the indicated Bolt, but do not tighten the other Bolt yet.**

Attach the Left Handrail (not shown) as described above. Note: There is not a wire harness on the left side.

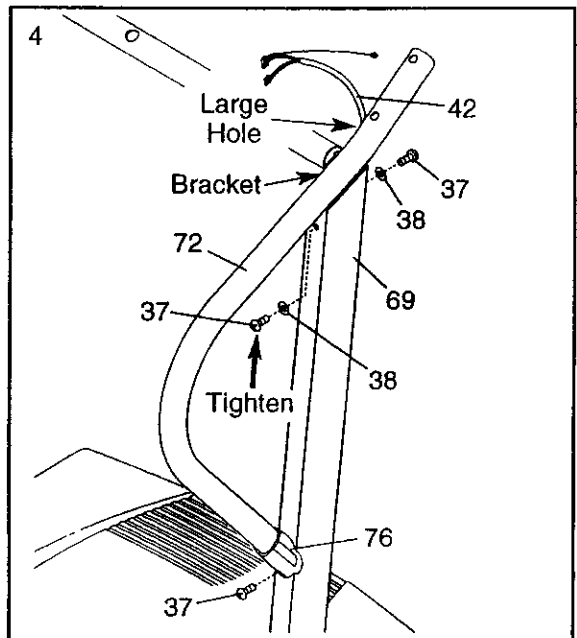

- Attach the end of the ground wire to the small hole in the side of the Right Handrail (72) with a Silver Ground Screw (75).

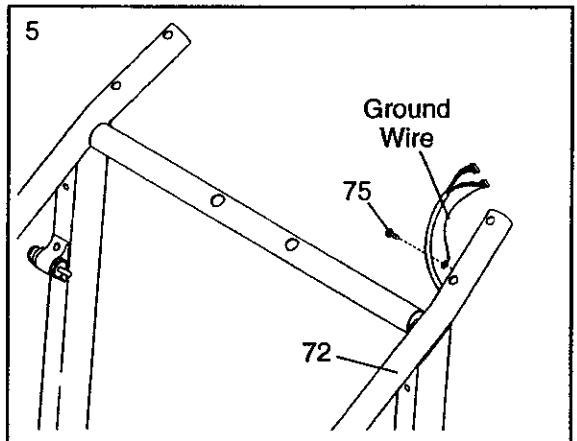

- Place the Console Base (47) on the Right Handrail (72) and the Left Handrail (not shown). Attach the Console Base with four 3/4" Screws (2) (only two Screws are shown). **Do not overtighten the Screws.**

Insert the Wire Harness (42) through the two indicated plastic ties on the Console Base (47). Next, **touch the Right Handrail (72) to discharge any static.** Plug the widest connector on the Wire Harness into the widest connector on the back of the Console (43). **If the connector does not fit easily, rotate it and then connect it.** Plug the other connector on the Wire Harness into the other connector on the Console.

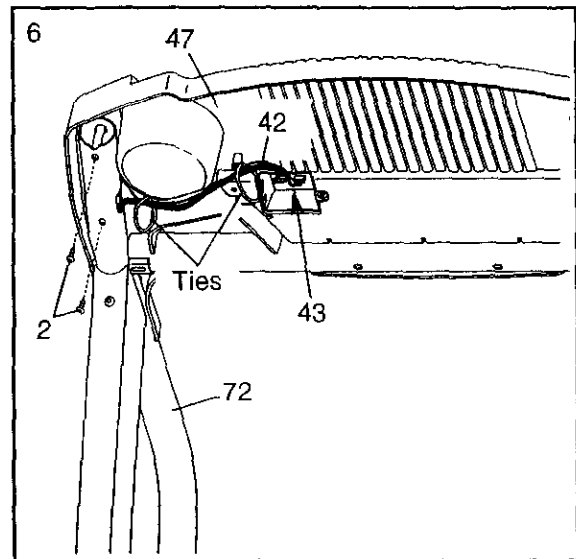

- Insert the excess Wire Harness (42) into the large hole in the side of the Right Handrail (72). **Securely tighten the plastic ties on the bottom of the Console Base (47) to prevent the Wire Harness from slipping.** Then, cut off the ends of the plastic ties.

Route the Wire Harness (42) through the indicated opening in the Console Base (47). Attach the Wire Cover (44) to the Console Base (47) with a 1/2" Silver Screw (48).

Tighten two 3/4" Screws (2) into the Console Base (47).

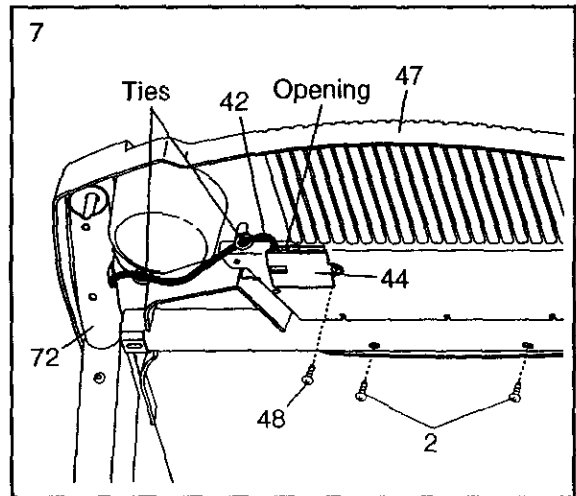

- Attach a Wheel (66) to the inner side of each Extension Leg (63) with a Wheel Bolt (64) and a Wheel Nut (13) as shown. **Do not overtighten the Bolt.** The Wheel should be able to spin freely.

Lift the treadmill frame (see HOW TO FOLD THE TREADMILL FOR STORAGE on page 11), but do not latch it. Make sure that the frame is centered between the Handrails (not shown). **Firmly tighten the bolts used in assembly step 4.** Then, lower the frame to the floor.

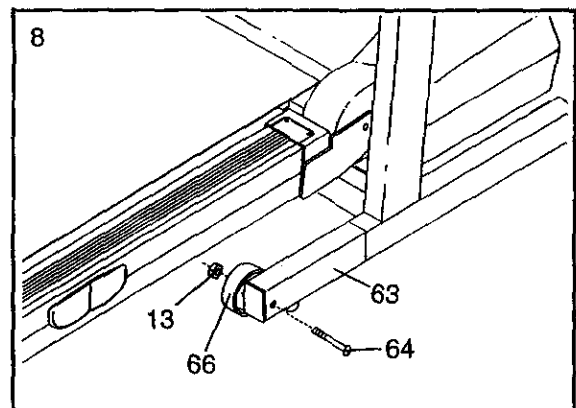

- Make sure that all parts are properly tightened before you use the treadmill.** Note: Extra hardware may be included. Keep the included allen wrenches in a secure place. The large allen wrench is used to adjust the walking belt (see page 14). To protect the floor or carpet, place a mat under the treadmill.

# OPERATION AND ADJUSTMENT

## THE PERFORMANT LUBE™ WALKING BELT

Your treadmill features a walking belt coated with PERFORMANT LUBE™, a high-performance lubricant. **IMPORTANT:** Never apply silicone spray or other substances to the walking belt or the walking platform. Such substances will deteriorate the walking belt and cause excessive wear.

## HOW TO PLUG IN THE POWER CORD

**⚠ DANGER:** Improper connection of the equipment-grounding conductor can result in an increased risk of electric shock. Check with a qualified electrician or serviceman if you are in doubt as to whether the product is properly grounded. Do not modify the plug provided with the product—if it will not fit the outlet, have a proper outlet installed by a qualified electrician.

Your treadmill, like any other type of sophisticated electronic equipment, can be seriously damaged by sudden voltage changes in your home's power. Voltage surges, spikes, and noise interference can result from weather conditions or from other appliances being turned on or off. **To decrease the possibility of your treadmill being damaged, always use a surge suppressor with your treadmill (see drawing 1 at the right).** To purchase a surge suppressor, see your local SEARS or call 1-800-366-7278 and order part number 146148.

Use only a single-outlet surge suppressor that is UL 1449 listed as a transient voltage surge suppressor (TVSS). The surge suppressor must have a UL suppressed voltage rating of 400 volts or less and a minimum surge dissipation of 450 joules. The surge suppressor must be electrically rated for 120 volts AC and 15 amps. There must be a monitoring light on the surge suppressor to indicate whether it is functioning properly. Failure to use a properly functioning surge suppressor could result in damage to the control system of the treadmill. If the control system is damaged, the walking belt may change speed or stop unexpectedly, which may result in a fall and serious injury.

**This product must be grounded.** If it should malfunction or break down, grounding provides a path of least resistance for electric current to reduce the risk of electric shock. This product is equipped with a cord having

an equipment-grounding conductor and a grounding plug. **Plug the power cord into a surge suppressor, and plug the surge suppressor into an appropriate outlet that is properly installed and grounded in accordance with all local codes and ordinances. Important: The treadmill is not compatible with GFCI-equipped outlets.**

This product is for use on a nominal 120-volt circuit, and has a grounding plug that looks like the plug illustrated in drawing 1 below. A temporary adapter that looks like the adapter illustrated in drawing 2 may be used to connect the surge suppressor to a 2-pole receptacle as shown in drawing 2 if a properly grounded outlet is not available.

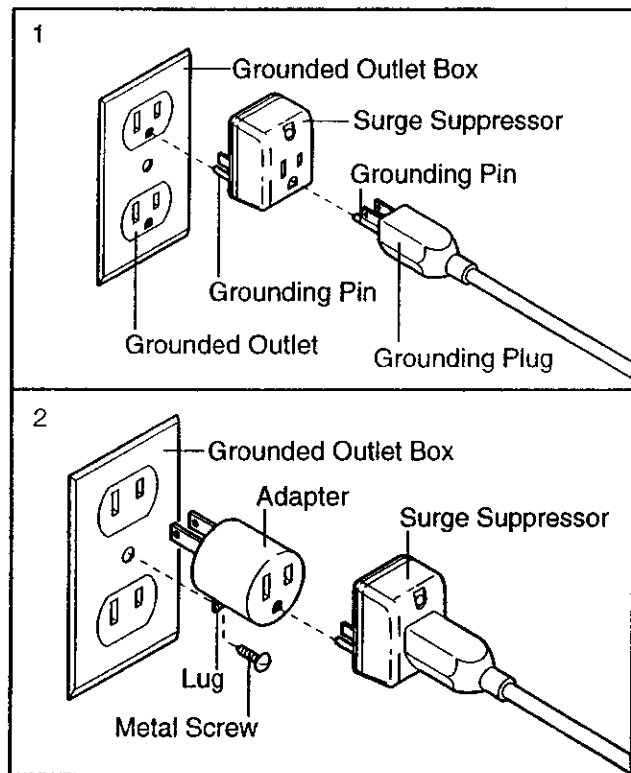

The temporary adapter should be used only until a properly grounded outlet (drawing 1) can be installed by a qualified electrician.

The green-colored rigid ear, lug, or the like extending from the adapter must be connected to a permanent ground such as a properly grounded outlet box cover. Whenever the adapter is used it must be held in place by a metal screw. **Some 2-pole receptacle outlet box covers are not grounded. Contact a qualified electrician to determine if the outlet box cover is grounded before using an adapter.**



## CONSOLE DIAGRAM

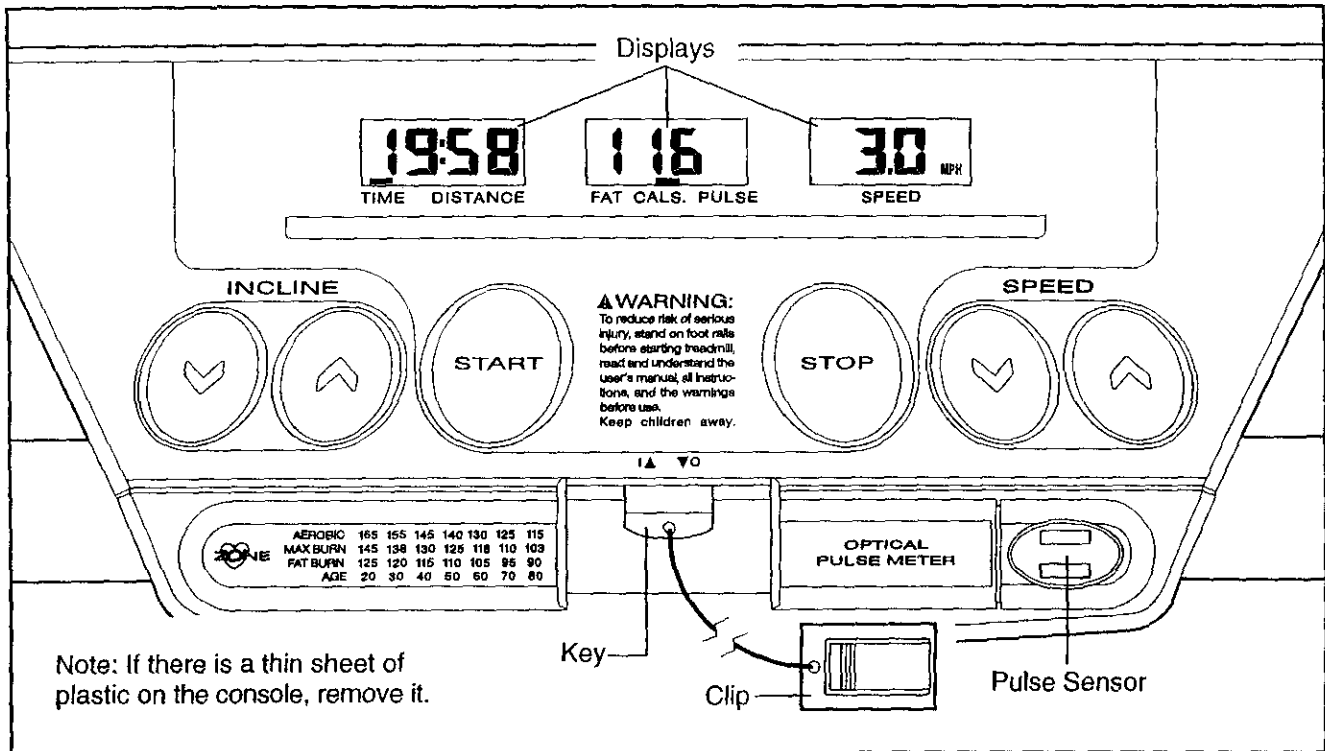

### ⚠ CAUTION: Before operating the console, read the following precautions.

- Do not stand on the walking belt when turning on the power.
- Always wear the clip (see the drawing above) while operating the treadmill.
- Adjust the speed in small increments to avoid sudden jumps in speed.
- To reduce the possibility of electric shock, keep the console dry. Avoid spilling liquids on the console and place only a sealed water bottle in the water bottle holder.

### STEP-BY-STEP CONSOLE OPERATION

Before operating the console, make sure that the power cord is properly plugged in (see page 8).

Next, stand on the foot rails of the treadmill. Find the clip attached to the key (see the drawing above), and slide the clip onto the waistband of your clothes.

Insert the key fully into the console. After a moment, the displays will light. **Test the clip by carefully taking a few steps backward until the key is pulled from the console.** If the key is not pulled from the console, adjust the position of the clip.

Follow the steps below to operate the console.

#### **1** Insert the key fully into the console.

A few seconds after the key is inserted, the displays will light.

#### **2** Press the Start button or the Speed ▲ button to start the walking belt.

A moment after the button is pressed, the walking belt will begin to move. Hold the handrails and begin walking.

As you exercise, change the speed of the walking belt as desired by pressing the Speed buttons. Each time a button is pressed, the speed setting will change by 0.1 mph; if a button is held down, the speed setting will change in increments of 0.5 mph. **Note: The console can display speed and distance in either miles or kilometers (see SPEED DISPLAY on page 10).** For simplicity, all instructions in this section refer to miles.

To stop the walking belt, press the Stop button. The elapsed time will begin to flash in the Time/Distance display.

Note: During the first few minutes that the treadmill is used, inspect the alignment of the walking belt, and align it if necessary (see page 14).

### 3 Change the incline of the treadmill as desired.

To change the incline of the treadmill, press either of the Incline buttons until the desired incline level is reached.

### 4 Follow your progress with the three displays.

**Time/Distance display**—This display shows the elapsed time and the distance that you have walked or run. The display will change from one number to the other every few seconds, as shown by the mode indicators. When the Stop button is pressed, the elapsed time will flash.

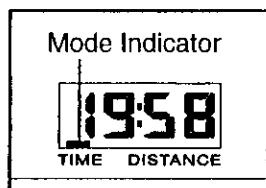

**Fat Calories/Calories/Pulse display**—This display shows the approximate numbers of *fat calories* and *calories* you have burned (see **FAT BURNING** on page 15). The display will change from one number to the other every few seconds, as shown by the mode indicators. The display will also show your heart rate when you use the pulse sensor (see step 5).



**Speed display**—This display shows the speed of the walking belt

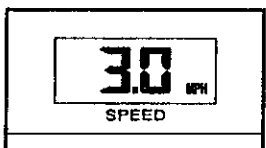

Note: The console can display speed and distance in either miles or kilometers. To change the unit of measurement, hold down the Stop button, insert the key into the console, and

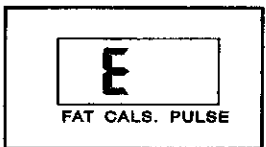

continue to hold the Stop button for a moment. An "E" for English miles or an "M" for metric kilometers will appear in the Fat Calories/Calories/Pulse display. Press the Speed  $\Delta$  button to change the unit of measurement. When the desired unit of measurement is selected, remove the key and then reinsert it.

To reset the displays, press the Stop button, remove the key, and then reinsert the key.

### 5 Measure your heart rate if desired.

To measure your heart rate, stand on the foot rails and place your thumb on the pulse sensor. **Do not press too hard, or the circulation in your**

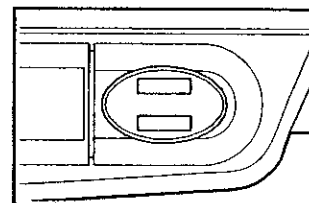

**thumb will be restricted and your pulse will not be detected.** After a few seconds, the heart-shaped indicator in the Fat Calories/Calories/Pulse display will begin to flash, one or two dashes (--) will appear, and then your heart rate will be shown. Hold your thumb on the pulse sensor for about 15 seconds for the most accurate reading.

If the displayed heart rate appears to be too high or too low, or if your heart rate is not displayed, lift your thumb off the pulse sensor for a few seconds. Then, place your thumb on the pulse sensor as described above. Remember to stand still while measuring your heart rate.

### 6 When you are finished exercising, remove the key.

Step onto the foot rails, press the Stop button, and remove the key from the console. Keep the key in a secure place.

**WARNING:** Removing the key does not cut off power to the incline system. To prevent movement of the treadmill and possible injury, unplug the power cord when the treadmill is not in use.

# HOW TO FOLD AND MOVE THE TREADMILL

## HOW TO FOLD THE TREADMILL FOR STORAGE

Before folding the treadmill, unplug the power cord. **CAUTION: You must be able to safely lift 45 pounds (20 kg) in order to raise, lower, or move the treadmill.**

1. Hold the treadmill with your hands in the locations shown at the right. **To decrease the possibility of injury, bend your legs and keep your back straight. As you raise the treadmill, make sure to lift with your legs rather than your back.** Raise the treadmill about halfway to the vertical position.

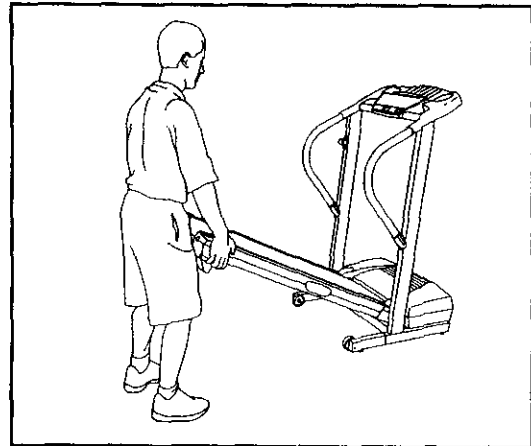

2. Move your right hand to the position shown and hold the treadmill firmly. Using your left hand, pull the latch knob to the left and hold it. Raise the treadmill until the latch pin is aligned with the square hole between the frame and the foot rail. Slowly release the latch knob and insert the latch pin into the hole. **Make sure that the frame is securely held by the latch pin.**

**To protect the floor or carpet from damage, place a mat under the treadmill. Keep the treadmill out of direct sunlight. Do not leave the treadmill in the storage position in temperatures above 85° Fahrenheit.**

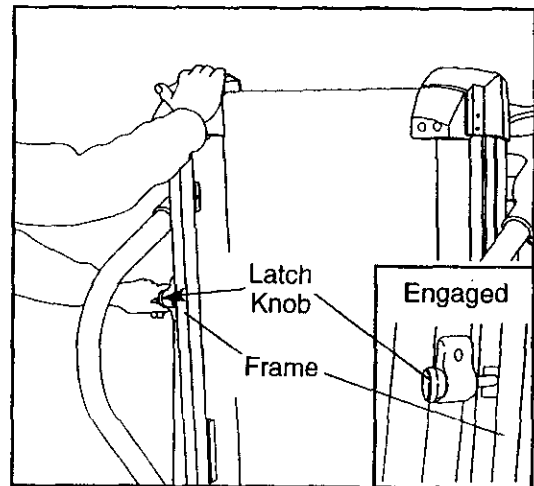

## HOW TO MOVE THE TREADMILL

Before moving the treadmill, convert the treadmill to the storage position as described above. **Make sure that the frame is securely held by the latch pin.**

1. Hold the upper ends of the handrails. Place one foot on the base as shown.
2. Tilt the treadmill back until it rolls freely on the front wheels. Carefully move the treadmill to the desired location. **To reduce the risk of injury, use extreme caution while moving the treadmill. Do not move the treadmill over an uneven surface.**
3. Place one foot on the base, and carefully lower the treadmill until it is resting in the storage position.

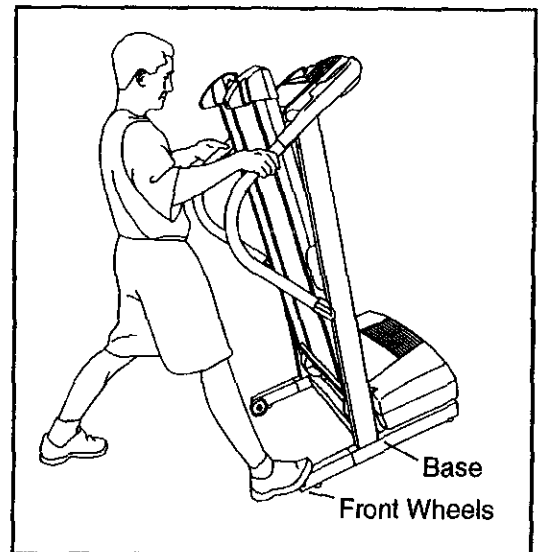

## HOW TO LOWER THE TREADMILL FOR USE

1. Hold the upper end of the treadmill with your right hand as shown. Using your left hand, pull the latch knob to the left and hold it. Pivot the treadmill down until the frame is past the latch pin. Slowly release the latch knob.

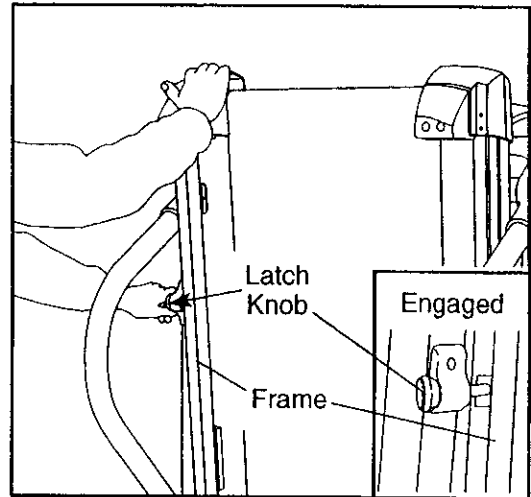

2. Hold the treadmill firmly with both hands, and lower the treadmill to the floor. **Do not drop the treadmill frame to the floor. To decrease the possibility of injury, bend your legs and keep your back straight.**

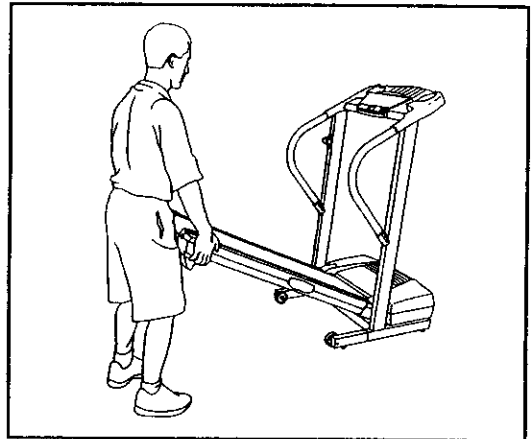

# TROUBLESHOOTING

Most treadmill problems can be solved by following the simple steps below. Find the symptom that applies, and follow the steps listed. If further assistance is needed, call our toll-free HELPLINE at 1-800-736-6879, Monday through Saturday, 7 a.m. until 7 p.m. Central Time (excluding holidays).

**PROBLEM: The power does not turn on**

**SOLUTION:** a. Make sure that the power cord is plugged into a surge suppressor, and that the surge suppressor is plugged into a properly grounded outlet (see page 8). Use only a single-outlet surge suppressor that meets all of the specifications described on page 8. Important: The treadmill is not compatible with GFCI-equipped outlets.

b. After the power cord has been plugged in, make sure that the key is fully inserted into the console.

c. Check the circuit breaker located on the treadmill frame near the power cord. If the switch protrudes as shown, the circuit breaker has tripped. To reset the circuit breaker, wait for five minutes and then press the switch back in.

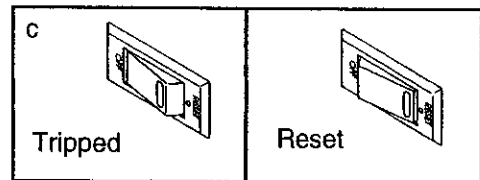

**PROBLEM: The power turns off during use**

**SOLUTION:** a. Check the circuit breaker located on the treadmill frame near the power cord (see the drawing above). If the circuit breaker has tripped, wait for five minutes and then press the switch back in.

b. Make sure that the power cord is plugged in. If the power cord is plugged in, unplug it, wait for five minutes, and then plug it back in.

c. Remove the key from the console. Reinsert the key fully into the console.

d. If the treadmill still will not run, please call our toll-free HELPLINE.

**PROBLEM: The displays of the console do not function properly**

**SOLUTION:** a. Remove the key from the console and **UNPLUG THE POWER CORD**. Remove the two 3/4" Screws (2) from the hood, and carefully pivot the Hood (1) off.

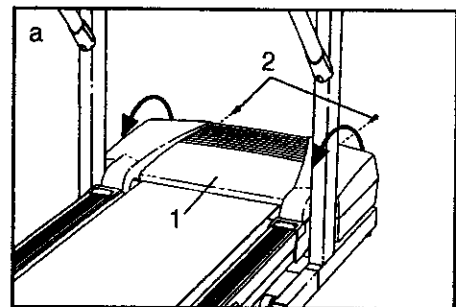

Locate the Reed Switch (10) and the Magnet (18) on the left side of the Pulley (17). Turn the Pulley until the Magnet is aligned with the Reed Switch. **Make sure that the gap between the Magnet and the Reed Switch is about 1/8"**. If necessary, loosen the Screw (56) and move the Reed Switch slightly. Retighten the Screw. Re-attach the Hood, and run the treadmill for a few minutes to check for a correct speed reading.

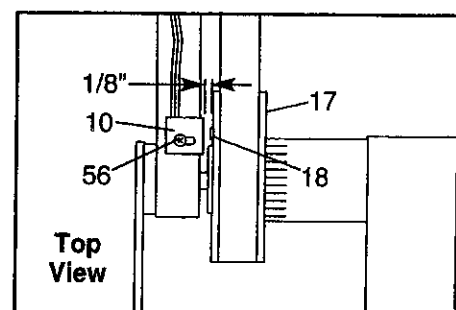

**PROBLEM: The walking belt slows when walked on**

**SOLUTION:** a. Use only a single-outlet surge suppressor that meets all of the specifications described on page 8.

b. If the walking belt is overtightened, treadmill performance may decrease and the walking belt may become damaged. Remove the key and **UNPLUG THE POWER CORD**. Using the allen wrench, turn both rear roller adjustment bolts counterclockwise, 1/4 of a turn. When the walking belt is properly tightened, you should be able to lift each side of the walking belt 2 to 3 inches off the walking platform. Be careful to keep the walking belt centered. Plug in the power cord, insert the key, and run the treadmill for a few minutes. Repeat until the walking belt is properly tightened.

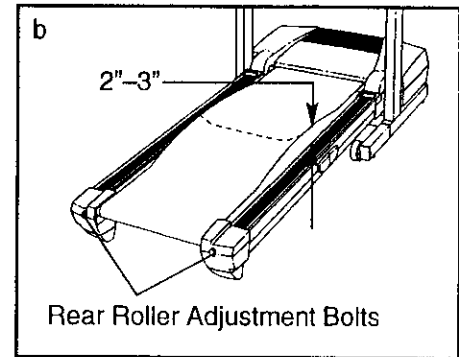

c. If the walking belt still slows when walked on, please call our toll-free HELPLINE.

**PROBLEM: The walking belt is off-center or slips when walked on**

**SOLUTION:** a. If the walking belt is off-center, first remove the key and **UNPLUG THE POWER CORD**. If the walking belt has shifted to the left, use the allen wrench to turn the left rear roller bolt clockwise 1/2 of a turn; if the walking belt has shifted to the right, turn the bolt counterclockwise 1/2 of a turn. Be careful not to overtighten the walking belt. Plug in the power cord, insert the key, and run the treadmill for a few minutes. Repeat until the walking belt is centered.

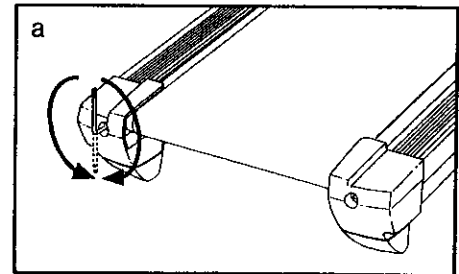

b. If the walking belt slips when walked on, first remove the key and **UNPLUG THE POWER CORD**. Using the allen wrench, turn both rear roller bolts clockwise, 1/4 of a turn. When the walking belt is correctly tightened, you should be able to lift each side of the walking belt 2 to 3 inches off the walking platform. Be careful to keep the walking belt centered. Plug in the power cord, insert the key, and carefully walk on the treadmill for a few minutes. Repeat until the walking belt is properly tightened.

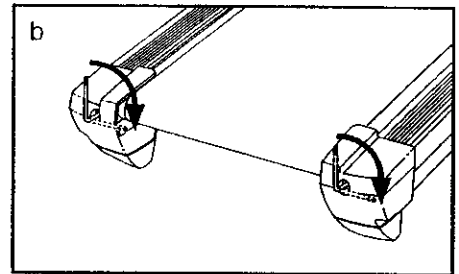

# CONDITIONING GUIDELINES

**⚠ WARNING:** Before beginning this or any exercise program, consult your physician. This is especially important for individuals over the age of 35 or individuals with pre-existing health problems.

The pulse sensor is not a medical device. Various factors, including your movement, may affect the accuracy of heart rate readings. The sensor is intended only as an exercise aid in determining heart rate trends in general.

The following guidelines will help you to plan your exercise program. For more detailed exercise information, obtain a reputable book or consult your physician.

## EXERCISE INTENSITY

Whether your goal is to burn fat or to strengthen your cardiovascular system, the key to achieving the desired results is to exercise with the proper intensity. The proper intensity level can be found by using your heart rate as a guide. The chart below shows recommended heart rates for fat burning and aerobic exercise.

	165	155	145	140	130	125	115
AEROBIC							
MAX FAT BURN	145	138	130	125	118	110	103
FAT BURN	125	120	115	110	105	95	90
Age	20	30	40	50	60	70	80

To find the proper heart rate for you, first find your age near the bottom of the chart (ages are rounded off to the nearest ten years). Next, find the three numbers above your age. The three numbers define your "training zone." The lower two numbers are recommended heart rates for fat burning; the higher number is the recommended heart rate for aerobic exercise.

To measure your heart rate during exercise, use the pulse sensor. If your heart rate is too high or too low, adjust the speed and incline of the treadmill.

## Fat Burning

To burn fat effectively, you must exercise at a relatively low intensity level for a sustained period of time. During the first few minutes of exercise, your body uses easily accessible *carbohydrate calories* for en-

ergy. Only after the first few minutes does your body begin to use stored *fat calories* for energy. If your goal is to burn fat, adjust the speed and incline of the treadmill until your heart rate is near the lowest number in your training zone.

For maximum fat burning, adjust the speed and incline of the treadmill until your heart rate is near the middle number in your training zone.

## Aerobic Exercise

If your goal is to strengthen your cardiovascular system, your exercise must be "aerobic." Aerobic exercise is activity that requires large amounts of oxygen for prolonged periods of time. This increases the demand on the heart to pump blood to the muscles, and on the lungs to oxygenate the blood. For aerobic exercise, adjust the speed and incline of the treadmill until your heart rate is near the highest number in your training zone.

## WORKOUT GUIDELINES

Each workout should include the following three parts:

**A Warm-up**—Start each workout with 5 to 10 minutes of stretching and light exercise. A proper warm-up increases your body temperature, heart rate and circulation in preparation for exercise.

**Training Zone Exercise**—After warming up, increase the intensity of your exercise until your pulse is in your training zone for 20 to 60 minutes. (During the first few weeks of your exercise program, do not keep your pulse in your training zone for longer than 20 minutes.) Breathe regularly and deeply as you exercise—never hold your breath.

**A Cool-down**—Finish each workout with 5 to 10 minutes of stretching to cool down. This will increase the flexibility of your muscles and will help prevent post-exercise problems.

## EXERCISE FREQUENCY

To maintain or improve your condition, complete three workouts each week, with at least one day of rest between workouts. After a few months, you may complete up to five workouts each week if desired. The key to success is to make exercise a regular and enjoyable part of your everyday life.

# PART IDENTIFICATION CHART

Remove this chart and use it to identify small parts during assembly. Save this chart and the EXPLODED DRAWING/PART LIST for future reference.

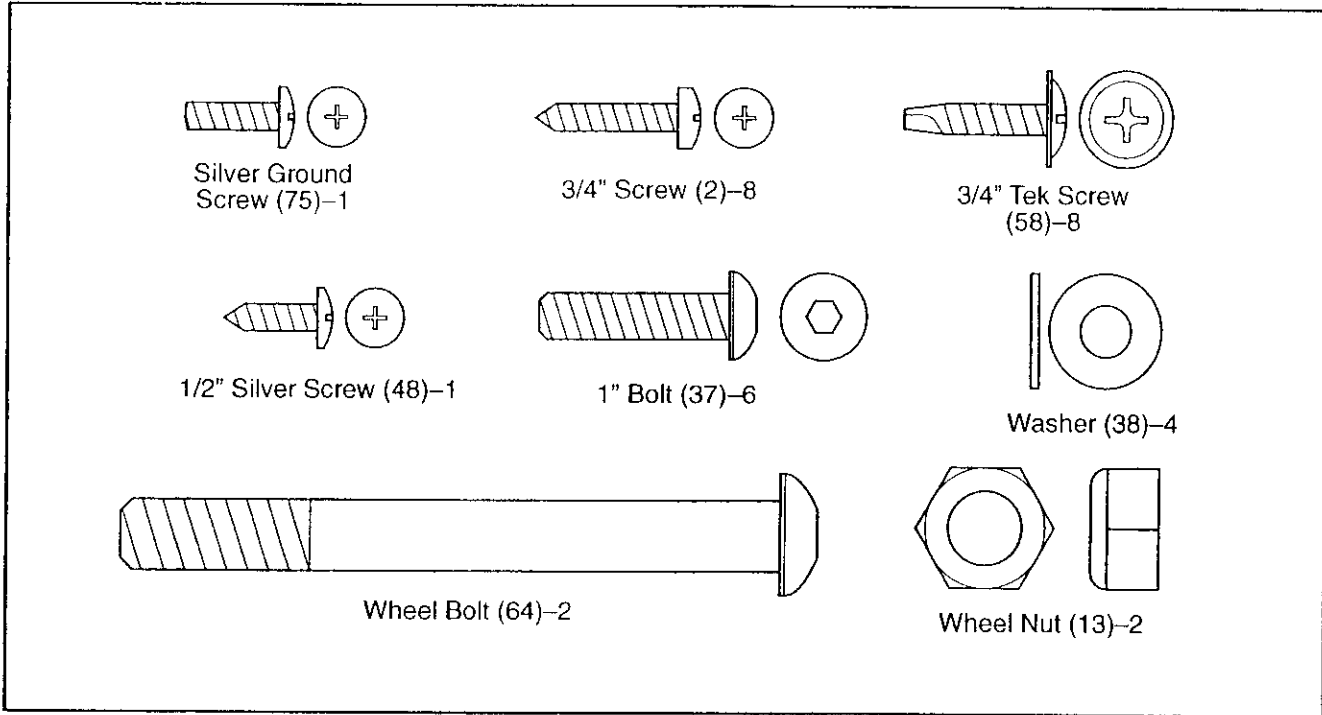



# PART LIST—Model No. 831.293032

R1102A

Key No.	Qty.	Description	Key No.	Qty.	Description
1	1	Hood	58	11	3/4" Tek Screw
2	15	3/4" Screw	59	1	Controller
3	1	Motor Belt	60	1	Lift Frame
4	1	Motor Tension Bolt	61*	2	Extension Leg Assembly
5	5	Flat Washer	62	2	Warning Decal
6	1	Motor Star Washer	63	2	Extension Leg
7	1	Flywheel	64	2	3 1/2" Bolt
8	1	Motor	65	4	Base Endcap
9*	1	Motor Assembly	66	2	Wheel
10	1	Reed Switch	67	1	Warning Decal
11	1	Latch Warning Decal	68	4	8" Cable Tie
12	2	Frame Spacer	69	1	Base
13	5	Frame Pivot Nut/Motor Nut	70	1	Grommet
14	2	Frame Pivot Bolt	71	1	Left Handrail
15	4	Walking Platform Screw	72	1	Right Handrail
16	1	Left Foot Rail	73	4	Cage Nut
17	1	Front Roller/Pulley	74	1	Left Foot Rail Endcap
18	1	Magnet	75	1	1/2" Silver Ground Screw
19	1	Motor Pivot Bolt	76	2	Handrail Cap
20	2	Motor Bracket Bolt	77	4	Belly Pan Screw
21	1	Right Foot Rail Endcap	78	1	Circuit Breaker
22	2	Belly Pan Clip	79	1	Power Cord
23	1	Front Roller Adjustment Bolt	80	1	Power Cord Grommet
24	4	Plastic Stand-off	81	1	Belly Pan
25	1	Electronics Bracket	82	2	Belt Guide
26	6	Electronics Screw	83	4	Belt Guide Screw
27	1	Power Board	84	4	Plastic Fastener
28	1	Motor Tension Nut	85	2	Isolator Cushion
29	1	Choke	86	1	Frame
30	1	Lock Knob	87	4	Releasable Tie
31*	1	Lock Knob Assembly	88	1	Incline Motor Wire
32	1	Spring	89	2	Cable Tie Clamp
33	1	Lock Pin Collar	90	1	Ground Wire
34	1	Lock Pin Clip	91	1	Right Rear Endcap Pad
35	1	Lock Pin	92	2	Rear Roller Adjustable Bolt
36	1	Storage Latch	93	1	Right Rear Endcap
37	6	1" Bolt	94	1	Allen Wrench
38	6	Washer	95	1	Left Rear Endcap
39	2	Crossbar Screw	96	1	Walking Belt
40	1	Crossbar	97	1	Walking Platform
41	1	5/32" Allen Wrench	98	1	Right Foot Rail
42	1	Wire Harness	99	1	Left Rear Endcap Pad
43	1	Console	100	1	Rear Roller
44	1	Wire Cover	101	2	Plastic Tie
45	1	Warning Decal	102	12	Rear Endcap Screw
46	1	Bookrack	103	1	Motor Mount Bracket
47	1	Console Base	#	1	8" Red Wire, M/F
48	1	1/2" Silver Screw	#	1	8" Blue Wire, 2F
49	2	1/2" Console Screw	#	1	4" Blue Wire, 2F
50	1	Key/Clip	#	1	4" White Wire, M/F
51	1	Incline Motor	#	1	8" White Wire, 2F
52	1	Incline Bracket	#	1	8" Green Wire, 2 Ring
53	2	Incline Motor Bolt	#	1	User's Manual
54	2	Clevis Pin			
55	2	Cotter Pin			
56	1	Motor Controller Wire			
57	4	Base Pad			

\* Includes all parts shown in the box

# These parts are not illustrated

# EXPLODED DRAWING—Model No. 831.293032

R1102A

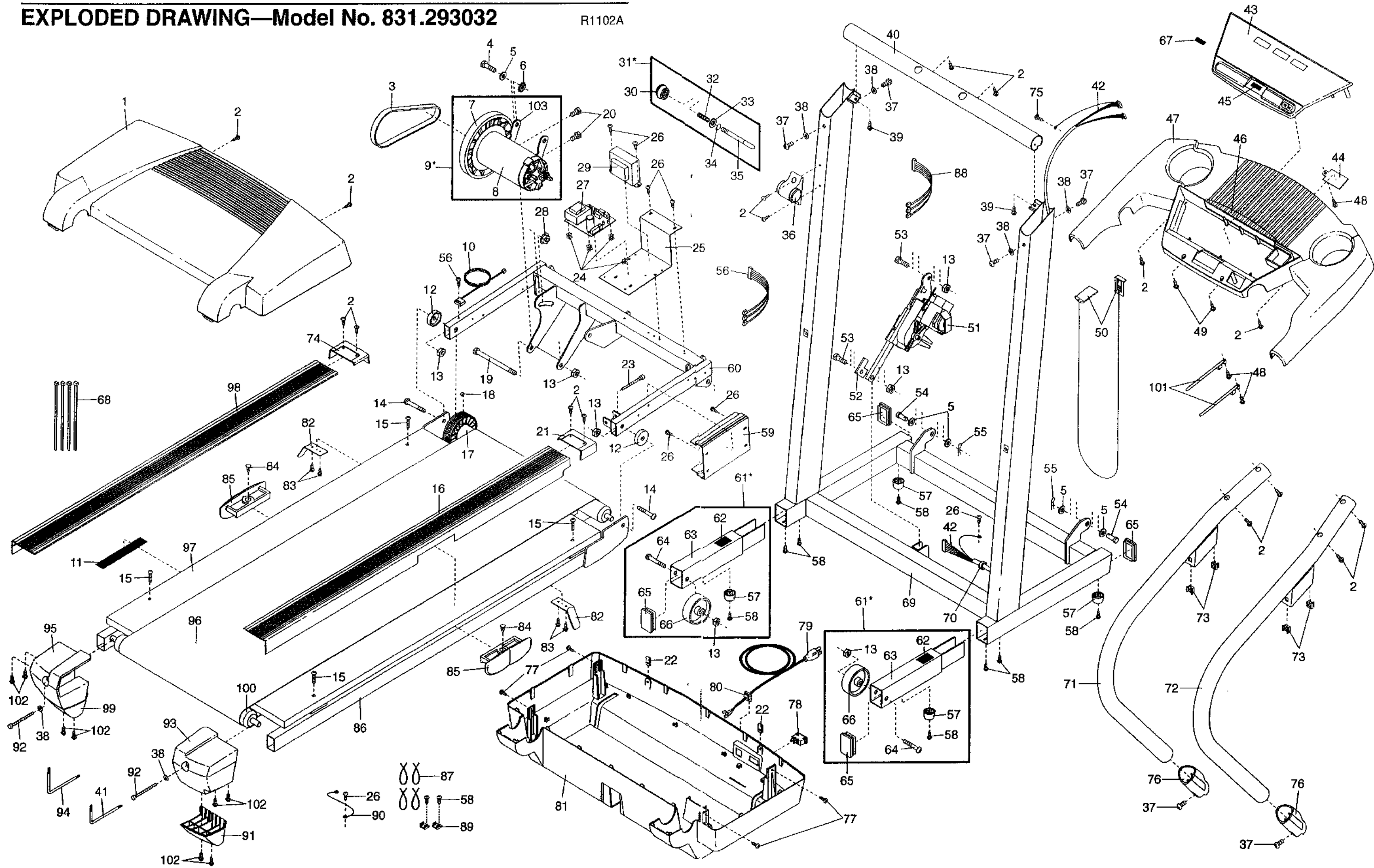



Model No. 831.293032

## QUESTIONS?

If you find that:

- you need help assembling or operating the PROFORM 320x treadmill
- a part is missing
- or you need to schedule repair service

call our toll-free HELPLINE

**1-800-736-6879**

Monday–Saturday, 7 am–7 pm  
Central Time (excluding holidays)

## REPLACEMENT PARTS

If parts become worn and need to be replaced, call the following toll-free number

**1-800-FON-PART**  
**(1-800-366-7278)**

The model number and serial number of your PROFORM® 320x treadmill are listed on a decal attached to the frame. See the front cover of this manual to find the location of the decal.

All replacement parts are available for immediate purchase or special order when you visit your nearest SEARS Service Center. To request service or to order parts by telephone, call the toll-free numbers listed at the left.

When requesting help or service, or ordering parts, please be prepared to provide the following information:

- The NAME OF THE PRODUCT (PROFORM® 320x treadmill)
- The MODEL NUMBER OF THE PRODUCT (831.293032)
- The KEY NUMBER AND DESCRIPTION OF THE PART (see the EXPLODED DRAWING and PART LIST in the center of this manual)

## FULL 90 DAY WARRANTY

For 90 days from the date of purchase, if failure occurs due to defect in material or workmanship in this SEARS TREADMILL EXERCISER, contact the nearest SEARS Service Center throughout the United States and SEARS will repair or replace the TREADMILL EXERCISER, free of charge.

This warranty does not apply when the TREADMILL EXERCISER is used commercially or for rental purposes.

This warranty gives you specific legal rights, and you may also have other rights which vary from state to state.

Sears, Roebuck and Co., Dept. 817WA, Hoffman Estates, IL 60179