

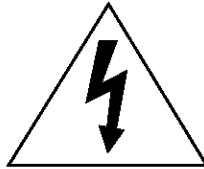

PROJECTION TELEVISION OWNER'S GUIDE



VS-45605
VS-50605
VS-50705
VS-55705
VS-60705
VS-70705



CAUTION

RISK OF ELECTRIC SHOCK
DO NOT OPEN



CAUTION: TO REDUCE THE RISK OF ELECTRIC SHOCK, DO NOT REMOVE COVER (OR BACK).
NO USER-SERVICEABLE PARTS INSIDE.
REFER SERVICING TO QUALIFIED SERVICE PERSONNEL.



The lightning flash with arrowhead symbol within an equilateral triangle is intended to alert the user to the presence of uninsulated “dangerous voltage” within the product’s enclosure that may be of sufficient magnitude to constitute a risk of electric shock.



The exclamation point within an equilateral triangle is intended to alert the user to the presence of important operating and maintenance (servicing) instructions in the literature accompanying the appliance.

Warning: To avoid permanently imprinting a fixed image onto your TV screen, please do not display the same stationary images on the screen for more than 15% of your total TV viewing in one week. Examples of stationary images are letterbox top/bottom bars from DVD disc or other video sources, side bars when showing standard TV pictures on widescreen TV’s, stock market reports, video game patterns, station logs, web sites or stationary computer images. Such patterns can unevenly age the picture tubes causing permanent damage to the TV. Please see page 58 for a detailed explanation.

Note: This equipment has been tested and found to comply with the limits for a Class B digital device, pursuant to part 15 of the FCC Rules. These limits are designed to provide reasonable protection against harmful interference in a residential installation. This equipment generates, uses and can radiate radio frequency energy and, if not installed and used in accordance with the instructions, may cause harmful interference to radio communications. However, there is no guarantee that interference will not occur in a particular installation. If this equipment does cause harmful interference to radio or television reception, which can be determined by turning the equipment off and on, the user is encouraged to try to correct the interference by one or more of the following measures:

- Reorient or relocate the receiving antenna
- Increase the separation between the equipment and receiver
- Connect the equipment into an outlet on a circuit different from that to which the receiver is connected
- Consult the dealer or an experienced radio/TV technician for help

Changes or modifications not expressly approved by Mitsubishi could void the user’s authority to operate this equipment.

WARNING:

TO REDUCE THE RISK OF FIRE OR ELECTRIC SHOCK, DO NOT EXPOSE THIS APPLIANCE TO RAIN OR MOISTURE.

CAUTION:

TO PREVENT ELECTRIC SHOCK, MATCH WIDE BLADE OF PLUG TO WIDE SLOT, FULLY INSERT.

NOTE TO CATV SYSTEM INSTALLER:

THIS REMINDER IS PROVIDED TO CALL THE CATV SYSTEM INSTALLER’S ATTENTION TO ARTICLE 820-40 OF THE NEC THAT PROVIDES GUIDELINES FOR PROPER GROUNDING AND, IN PARTICULAR, SPECIFIES THAT THE CABLE GROUND SHALL BE CONNECTED TO THE GROUNDING SYSTEM OF THE BUILDING, AS CLOSE TO THE POINT OF CABLE ENTRY AS PRACTICAL.

Contents

Important Safeguards	5
Instructions on safety and proper handling of your Mitsubishi television	
Special Features	7
Distinctive features, items included with your Mitsubishi television and hookup guidelines	
Shortcuts	8
A quick reference list	
Connections	9
Basic hookups to an antenna, cable and components	
Remote Control Functions	15
Features of the remote control, programming to work with other audio and video products, explanation of buttons	
The  Menu System	21
Explanation of the on-screen menu system and the basic set-up menu screens including Memorizing Channels, Set Clock and Day, AV Connection and On-Screen Language	
Remote Control Input and Channel Selection	31
Changing inputs and channels and setting the sleep timer with the remote control	
The Main Menu Screens	33
Explains the Parent Lock, Channel Edit, Advanced Features and Audio/Video Settings Menus	
Special Remote Control Functions	49
How the remote works with other products including the Mitsubishi A/V Network, viewing the PIP (Picture-in-Picture) and POP (Picture-outside-Picture)	
Control Panel Functions	54
Explanation of the front panel buttons and the back panel terminals	
Troubleshooting	57
Common problems, notes on caring and cleaning your Mitsubishi television and how to obtain service	
Appendices	61
Diamond Shield™ installation, remote control programming codes, bypassing the parent lock	

This page is blank

Important Safeguards

Please read all these instructions regarding your television set and retain for future reference. Follow all warnings and instructions marked on the television.

1. Read, Retain and Follow Instructions

Read all safety and operating instructions before operating the appliance. Retain the safety and operating instructions for future reference. Follow all operating and use instructions.

2. Heed Warnings

Adhere to all warnings on the appliance and in the operating instructions.

3. Cleaning

Unplug this TV receiver from the wall outlet before cleaning. Do not use liquid or aerosol cleaners. Cleaners can permanently damage the cabinet or screen. Use a damp cloth for cleaning.

4. Attachments and Equipment

Never add any attachments and/or equipment without approval of the manufacturer as such additions may result in the risk of fire, electric shock or other personal injury.

5. Water and Moisture

Do not use this TV receiver where contact with or immersion in water is possible. Do not use near bath tubs, wash bowls, kitchen sinks, laundry tubs, swimming pools, etc.

6. Accessories

Do not place this TV receiver on an unstable cart, stand, tripod, bracket, or table. The TV receiver may fall, causing serious injury to a child or adult, and serious damage to the appliance. Use only with a cart, stand, tripod, bracket, or table recommended by the manufacturer, or sold with the TV receiver. Any mounting of the appliance should follow the manufacturer's instructions, and should use a mounting accessory recommended by the manufacturer.



An appliance and cart combination should be moved with care. Quick stops, excessive force, and uneven surfaces may cause the appliance and cart combination to overturn.

7. Ventilation

Slots and openings in the cabinet are provided for ventilation and to ensure reliable operation of the TV receiver and to protect it from overheating. Do not block these openings or allow them to be blocked by placing the TV receiver on a bed, sofa, rug, or other similar surface. Nor should it be placed over a radiator or heat register. If the TV receiver is to be placed in a rack or bookcase, ensure that there is adequate ventilation and that the manufacturer's instructions have been adhered to.

8. Power Source

This TV receiver should be operated only from the type of power source indicated on the marking label. If you are not sure of the type of power supplied to your home, consult your appliance dealer or local power company.

9. Grounding or Polarization

This TV receiver is equipped with a polarized alternating current line plug having one blade wider than the other. This plug will fit into the power outlet only one way. If you are unable to insert the plug fully into the outlet, try reversing the plug. If the plug should still fail to fit, contact your electrician to replace your obsolete outlet. Do not defeat the safety purpose of the polarized plug.

10. Power-Cord Protection

Power-supply cords should be routed so that they are not likely to be walked on or pinched by items placed upon or against them, paying particular attention to cords at plugs, convenience receptacles, and the point where they exit from the appliance.

11. Lightning

For added protection for this TV receiver during a lightning storm, or when it is left unattended and unused for long periods of time, unplug it from the wall outlet and disconnect the antenna or cable system. This will prevent damage to the TV receiver due to lightning and power-line surges.

12. Power Lines

An outside antenna system should not be located in the vicinity of overhead power lines or other electric light or power circuits, or where it can fall into such power lines or circuits. When installing an outside antenna system, extreme care should be taken to keep from touching such power lines or circuits as contact with them might be fatal.

13. Overloading

Do not overload wall outlets and extension cords as this can result in a risk of fire or electric shock.

14. Object and Liquid Entry

Never push objects of any kind into this TV receiver through openings as they may touch dangerous voltage points or short-out parts that could result in a fire or electric shock. Never spill liquid of any kind on the TV receiver.

15. Outdoor Antenna Grounding

If an outside antenna or cable system is connected to the TV receiver, be sure the antenna or cable system is grounded so as to provide some protection against voltage surges and built-up static charges.

Section 810 of the National Electrical Code, ANSI/NFPA No. 70-1984, provides information with respect to proper grounding of the mast and supporting structure, grounding of the lead in wire to an antenna discharge unit, size of grounding conductors, location of antenna discharge unit, connection to grounding electrodes, and requirements for the grounding electrode.

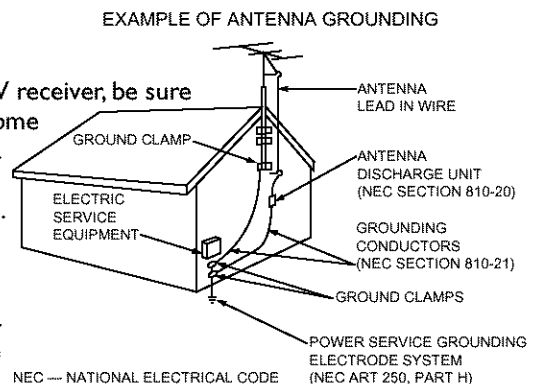

16. Servicing

Do not attempt to service this TV receiver yourself as opening or removing covers may expose you to dangerous voltage or other hazards. Refer all servicing to qualified service personnel.

17. Damage Requiring Service

Unplug this TV receiver from the wall outlet and refer servicing to qualified service personnel under the following conditions:

- When the power-supply cord or plug is damaged.
- If liquid has been spilled, or objects have fallen into the TV receiver.
- If the TV receiver has been exposed to rain or water.
- If the TV receiver does not operate normally by following the operating instructions, adjust only those controls that are covered by the operating instructions as an improper adjustment of other controls may result in damage and will often require extensive work by a qualified technician to restore the TV receiver to its normal operation.
- If the TV receiver has been dropped or the cabinet has been damaged.
- When the TV receiver exhibits a distinct change in performance — this indicates a need for service.

18. Replacement Parts

When replacement parts are required, be sure the service technician has used replacement parts specified by the manufacturer or have the same characteristics as the original part. Unauthorized substitutions may result in fire, electric shock or other hazards.

19. Safety Check

Upon completion of any service or repairs to this TV receiver, ask the service technician to perform safety checks to determine that the TV receiver is in safe operating condition.

Special Features

- ◇ **Component Video Input** - for the best picture from DVD players
- ◇ **DiamondShield™** - protective screen shield for models VS-50705, VS-55705, VS-60705 and VS-70705
- ◇ **IRIS™** - sensor that automatically adjusts brightness and contrast, for models VS-50705, VS-55705, VS-60705 and VS-70705
- ◇ **Multibrand Remote Control** - use one remote control for many audio video components

Unpacking Your TV

The following items are included with your new TV:

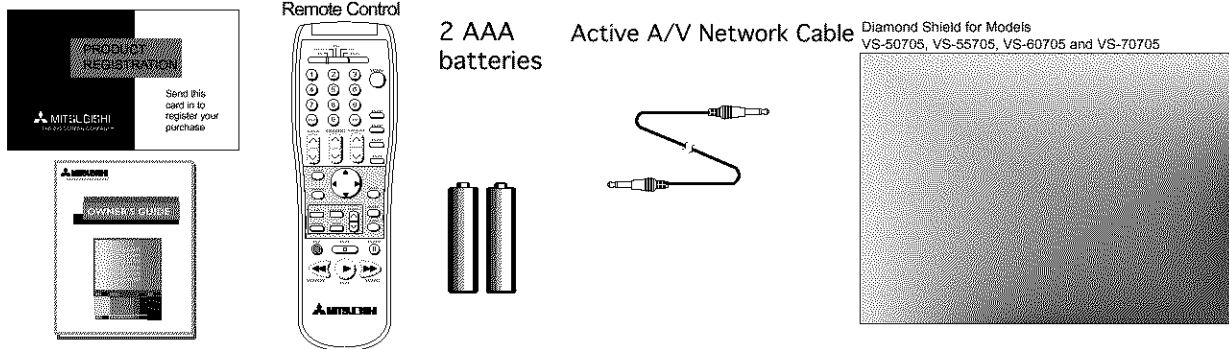

Choosing a Hookup

The connections shown in this book are general. Cable systems as well as individual audio and/or video components can vary from those shown here. The first diagram show basic connections to antenna or cable systems. After you have completed these, you can then connect any additional components (stereo, DVD, AV receiver, etc.).

IMPORTANT

To maximize your system for its best performance, your dealer can help you customize hookups and sell you any additional connection accessories that may be needed for your individual equipment.

Shortcuts

- ◇ **Hooking up your TV to an antenna or wall outlet cable - page 9**
- ◇ **Remote control functions - pages 19-20**
- ◇ **Menu screen summaries - page 22-24**
- ◇ **Selecting the input - page 31**
- ◇ **Setting the V-chip parent lock - page 33**
- ◇ **Picture-in-picture mode - page 50**
- ◇ **Picture-outside-picture mode
(for VS-50705, VS-55705, VS-60705 and VS-70705) - page 52**
- ◇ **Troubleshooting - page 57**

Connections

TV to Antenna or Wall Outlet Cable

Separate UHF and VHF antennas

1. Connect the UHF and VHF antenna leads to the UHF/VHF combiner.
2. Press the combiner onto ANT-A on the TV back panel.

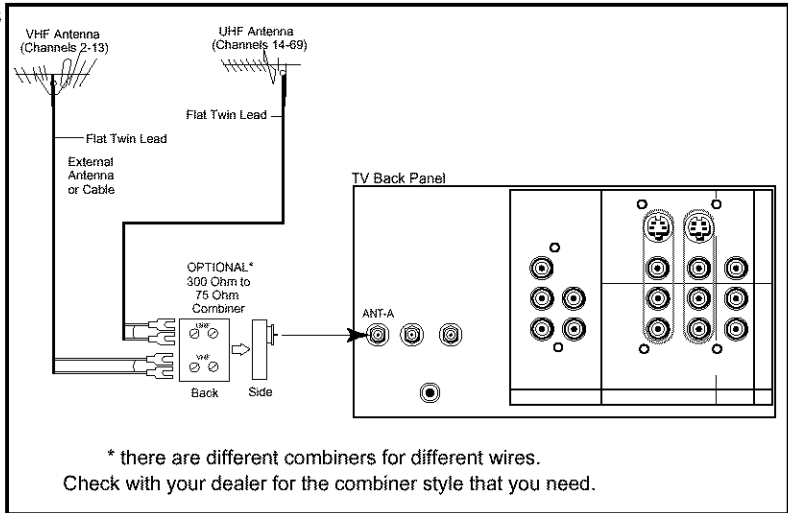

Twin lead antenna or wall outlet cable

For antenna with twin flat leads

1. Connect the 300 ohm twin leads to the transformer.
2. Push the 75 ohm side of the transformer onto ANT-A on the TV back panel.

For cable or antenna with coaxial lead

Connect the incoming cable to ANT-A on the TV back panel.

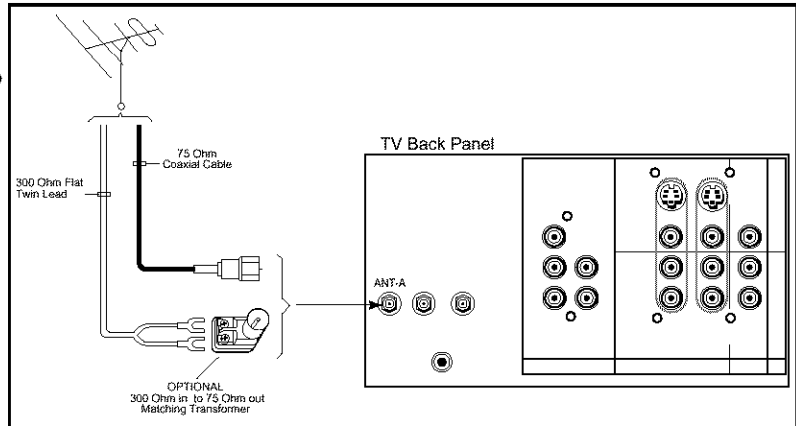

Connection of TV to Cable Box

1. Connect the incoming cable to ANT-A on the TV back panel.
2. Connect two coaxial cables as follows:
 - One from CABLE LOOP-OUT on the TV back panel to IN on the back of the cable box.
 - One from OUT on the back of the cable box to ANT-B on the TV back panel.

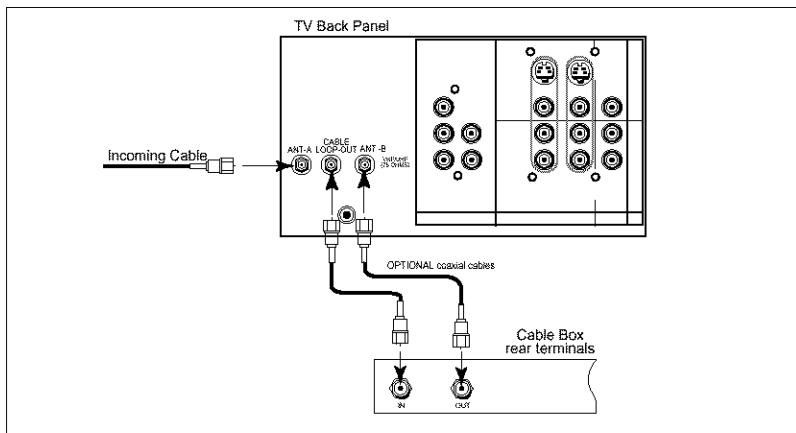

Connection of TV to VCR and Cable Box

1. Connect the incoming cable to ANT-A on the TV back panel.
2. Connect three coaxial cables as follows:
 - One from CABLE LOOP-OUT on the TV back panel to IN on the back of the cable box.
 - One from OUT on the back of the cable box to ANTENNA IN on the VCR back panel.
 - One from ANTENNA OUT on the VCR back panel to ANT-B on the TV back panel.

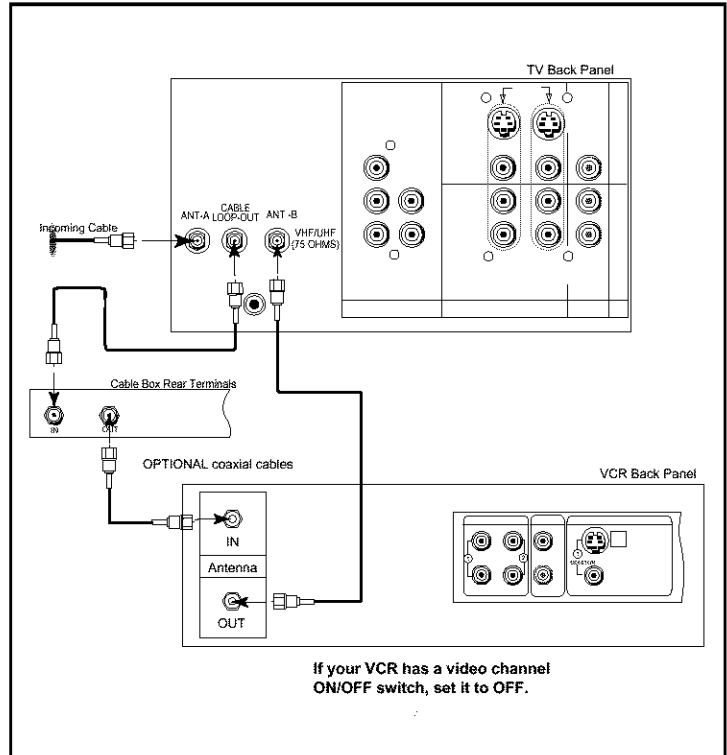

Audio Video Connections

1. Connect a video cable from VIDEO OUT on the VCR back panel to VIDEO INPUT 1 or INPUT 2 on the TV back panel.
- If you have a S-VHS VCR, follow the same steps, using the S-Video terminals on the VCR and TV.
2. Connect a set of audio cables from AUDIO OUT on the VCR back panel to AUDIO INPUT on the TV back panel. The red cable connects to the R (right) channel and the white cable connects to the L (left). If your VCR is non-stereo, connect only the L (left) cable.

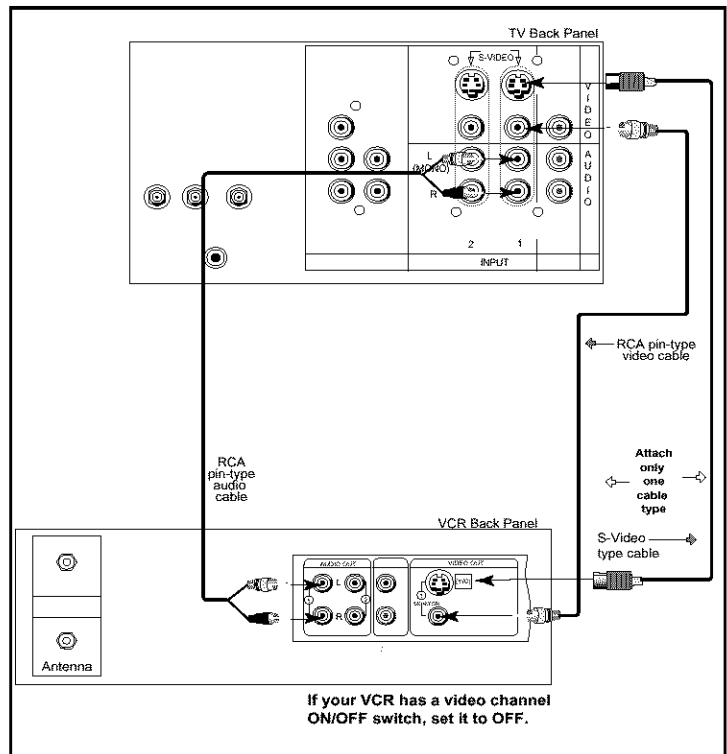

Connection of TV to VCR and Antenna or Wall Outlet Cable

Antenna/Cable Connections

1. Connect the incoming cable to ANT-A on the TV back panel.
2. Connect two coaxial cables as follows:
 - One from CABLE LOOP-OUT on the TV back panel to ANTENNA IN on the VCR back panel.
 - One from VCR back panel ANTENNA OUT to ANT-B on the TV back panel.

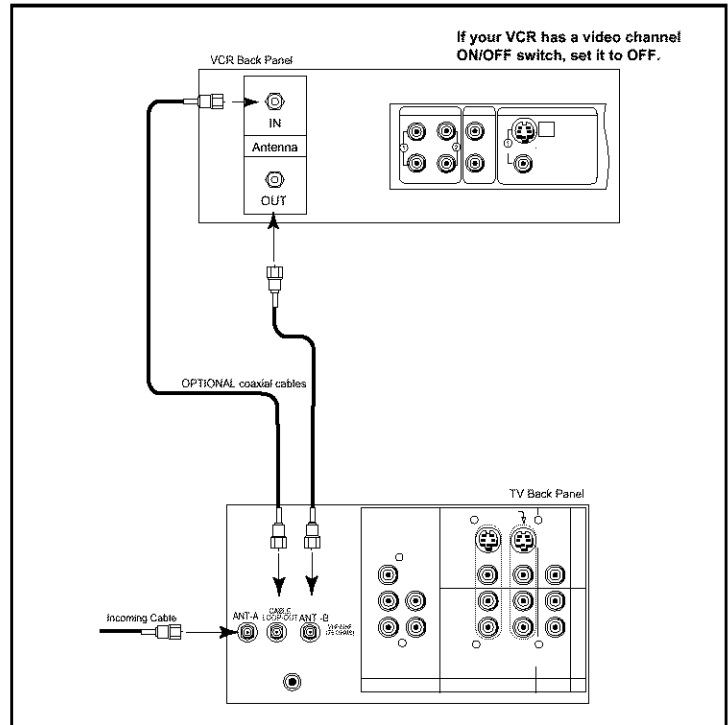

Audio/Video Connections

1. Connect a video cable from VIDEO OUT on the VCR back panel to VIDEO INPUT 1 or INPUT 2 on the TV back panel.
 - If you have a S-VHS VCR, follow the same steps, using the S-Video terminals on the VCR and TV.
2. Connect a set of audio cables from AUDIO OUT on the VCR back panel to AUDIO INPUT on the TV back panel. The red cable connects to the R (right) channel and the white cable connects to the L (left). If your VCR is non-stereo, only connect the L (left) cable.

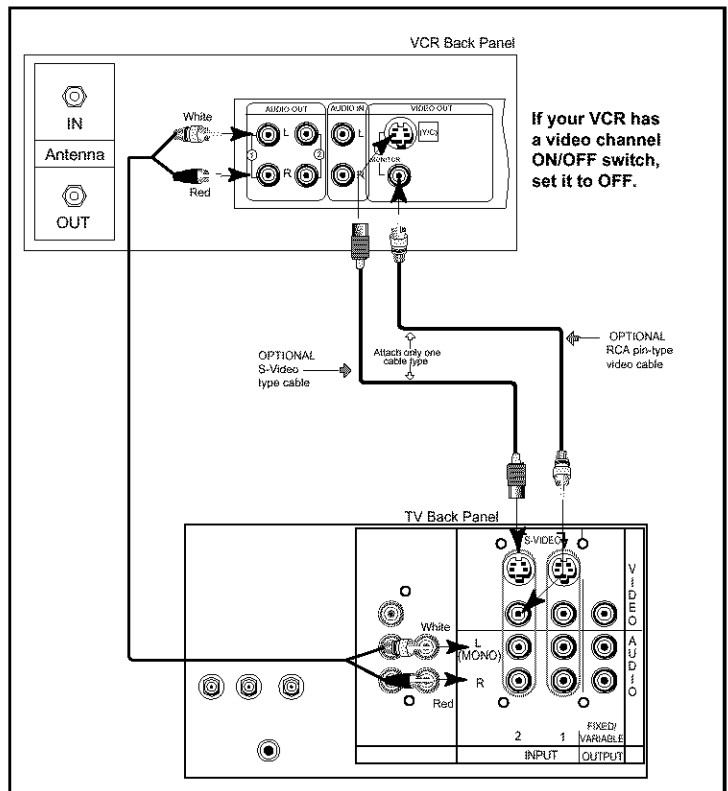

Connection of TV to Stereo Audio System

1. Connect the audio cables from AUDIO MONITOR OUTPUT on the TV back panel to TV IN or AUX IN terminals on the back of the audio system. The red cable connects to the R (right) channel and the white cable connects to the L (left) channel.
2. Turn off the TV's speakers through the AV Connection Menu (page 27).
3. Set the audio system's input to the TV or AUX position to hear the TV's audio through your stereo system.

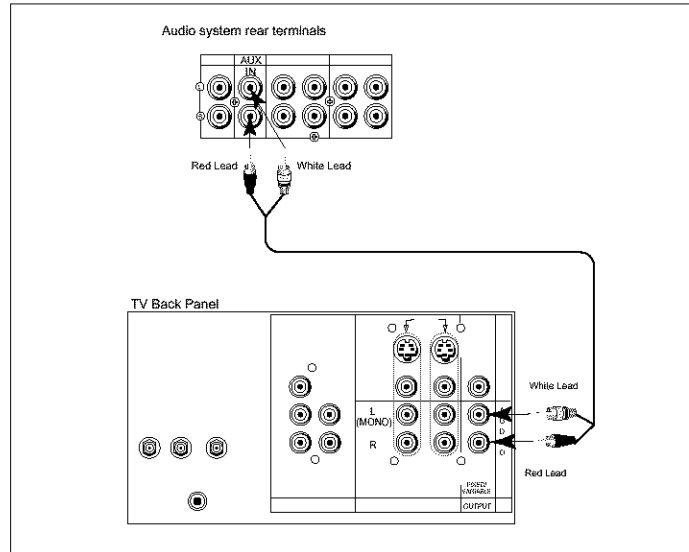

Connection of TV to the Active A/V Network

To control your Mitsubishi audio and/or video products with one remote control

Connect the A/V network cable from ACTIVE A/V NETWORK on the TV back panel to IN on the back of a Mitsubishi component that has A/V network terminal.

IMPORTANT

Check the Owner's Guide of your added Mitsubishi components to ensure the best possible connections.

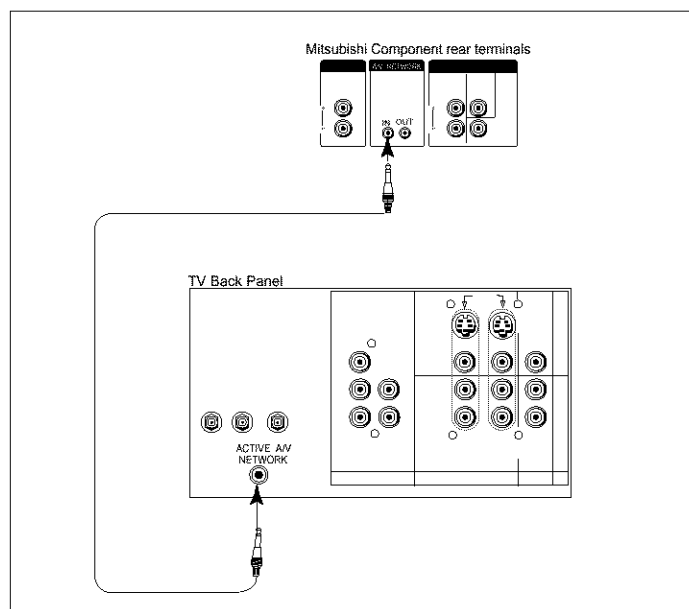

Connection of TV to AV Receiver

1. Connect a video cable from VIDEO MONITOR OUT on the back of the AV Receiver to VIDEO INPUT 1 on the TV back panel using a VIDEO cable.
2. Connect a video cable from VIDEO MONITOR OUTPUT on the TV back panel to VIDEO TV IN on the back of the AV Receiver.
3. Connect a set of audio cables from AUDIO OUTPUT on the TV back panel to AUDIO TV IN on the back of the AV Receiver. The red cable connects to the R (right) channel and the white cable connects to the L (left) channel.

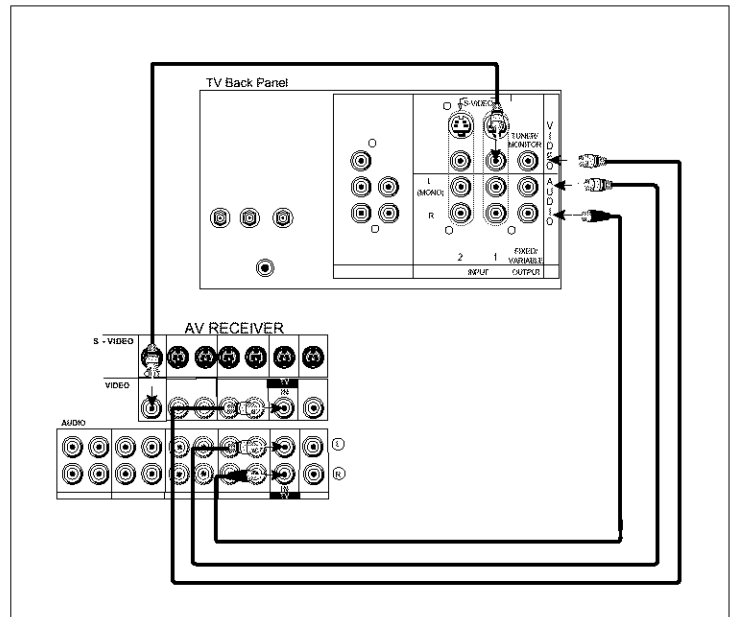

Connection of TV to DVD with Component Video Outputs

IMPORTANT

For Digital Audio connections, see the Owner's Guides of your DVD Player and AV Receiver.

For Component Video Connections

1. Connect the Component Video cables from VIDEO OUT on the back of the DVD player to DVD VIDEO INPUT on the TV back panel, matching the correct components:

- Y to Y,
- Cr to Cr,
- Cb to Cb.

2. Connect a set of audio cables from AUDIO OUT on the back of the DVD player to DVD AUDIO INPUT on the TV back panel. The red cable connects to the R (right) channel and the white cable connects to the L (left) channel.

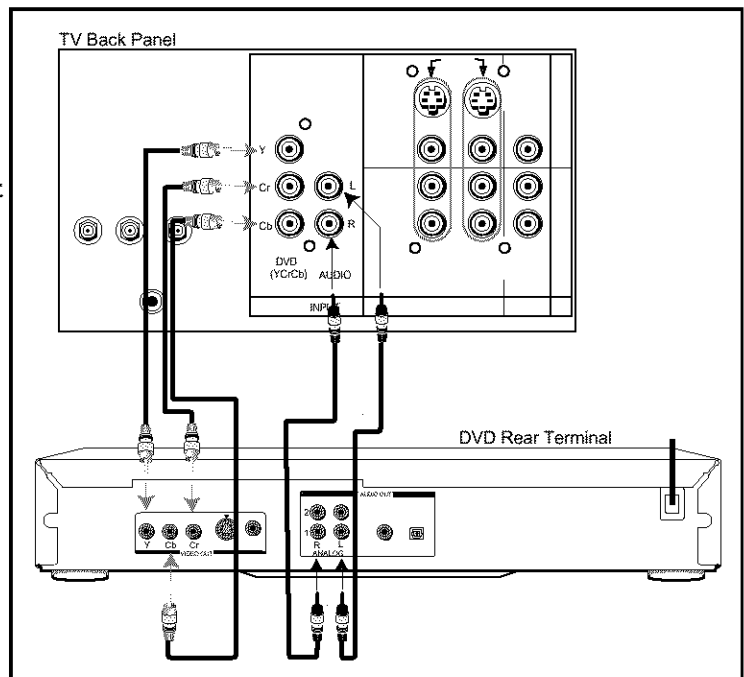

Warning: Don't display the same stationary images on the screen for more than 15% of your total TV viewing in one week. Examples of stationary images are letterbox top/bottom bars from DVD disc or other video sources, side bars when showing standard TV pictures on widescreen TV's, stock market reports, video game patterns, station logs, web sites or stationary computer images. Such patterns can unevenly age the picture tubes causing permanent damage to the TV. Please see page 58 for a detailed explanation.

Remote Control Functions

**For Models VS-45605
and VS-50605**

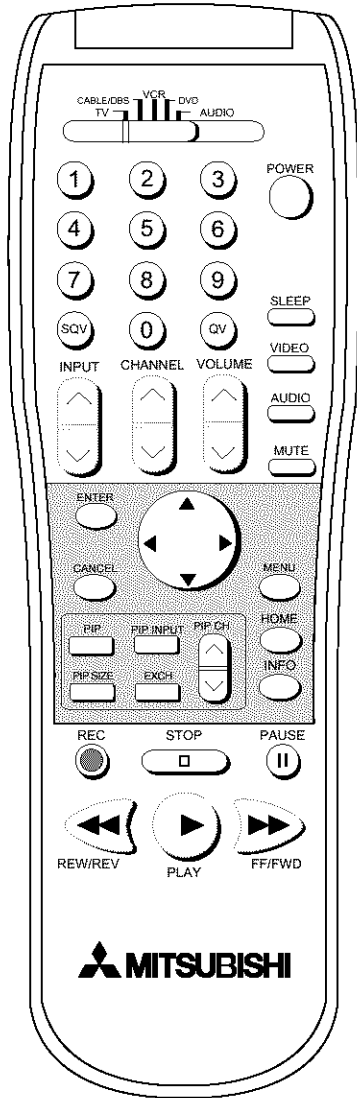

**Additional features of Models
VS-50705, VS-55705, VS-60705
and VS-70705**

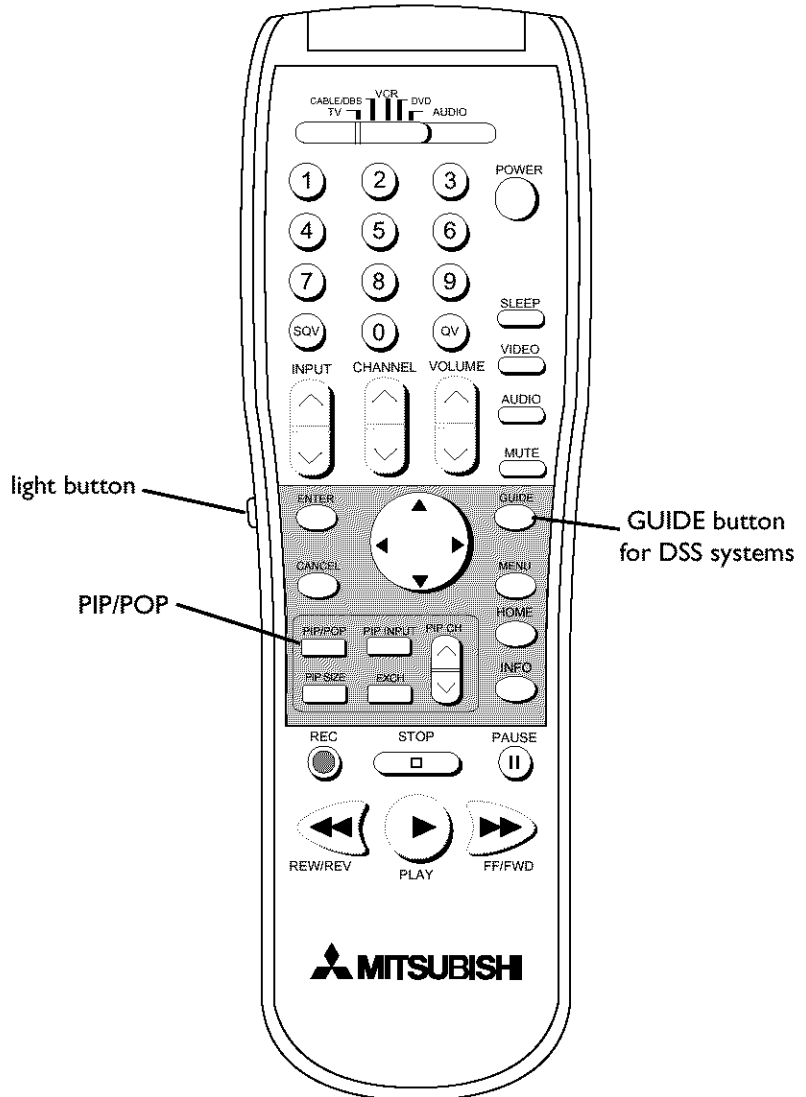

Operating Your Remote Control

Installing the batteries

1. Remove the back cover of the remote control by pushing the direction of the arrow and sliding off the cover.
2. Load the batteries, making sure the polarities(+) and (-) are correct.

IMPORTANT
When you replace the batteries in your remote control, the remote may return to its initial setting. You may need to set up your remote again.

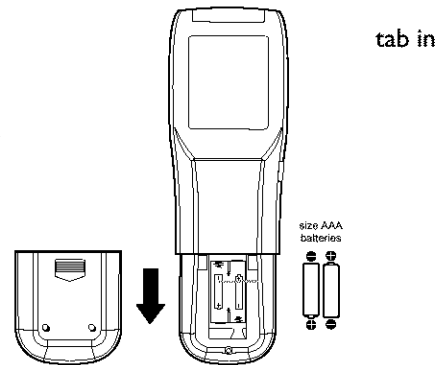

For best results

- Be within 20 feet of the equipment when using the remote control.
- Don't press two or more buttons at the same time, unless you are specifically instructed to do so in this owner's guide.
- Don't allow the remote control to get wet or become heated.
- Avoid dropping the remote control on a hard surface.
- When cleaning the remote control, don't use any harsh chemicals. Use only a soft, slightly moistened cloth.
- Don't mix new batteries with old ones.
- Don't heat, take apart, or throw batteries into a fire.
- Use alkaline batteries.

Using the remote control with your TV

You can use your remote to control the TV, CABLE/DBS, VCR, DVD or AUDIO. The remote has been preset to operate the TV and other Mitsubishi products. It can be set to control other audio/video equipment.

To operate the TV, the select switch at the top of the remote should be set to TV.

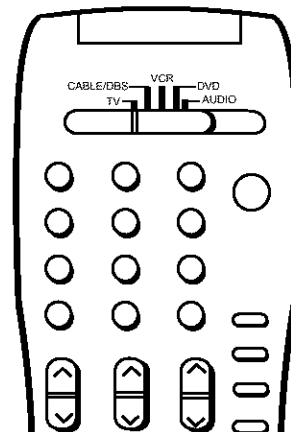

Remote Control of Other Audio and Video Products

Programming the Remote to Control Other Audio and Video Products:

- Move the slide switch at the top of the remote to select the audio or video product you want to control.
- Press and hold the POWER button, so that it stays down when you enter the code.
- Enter the code for the equipment from the appropriate list, exactly as stated. If there is more than one code number, start with the first number. After setting the code, release the POWER button.
- Point the remote at the equipment and press the POWER button. If it is on and turns off or is off and turns on, the remote will control the equipment. If not, try the next number.

Cable Box codes:

Cable box brand	code to enter:	If your cable box code is not listed here, please see page 63 for a complete listing.
General Instruments/ Jerrold	111, 119, 120, 121, 122, 123, 124, 125, 126, 127	
Oak	102, 137, 139	
Pioneer	101, 116	
Scientific Atlanta	111, 112, 113	
Zenith	100, 117	
To reset to default code, enter 000		

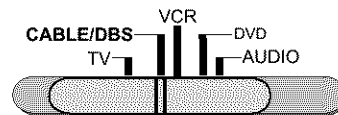

IMPORTANT

If you cannot turn the cable box ON by pressing POWER, try pressing the CHANNEL or the number buttons.

Satellite Receiver codes:

Satellite brand	code to enter:	If your satellite code is not listed here, please see page 63 for a complete listing.
Dishnetwork	175	
Hughes-DSS	173	
RCA-DSS	176	
Sony-DSS	177	
Toshiba-DSS	170	
Panasonic-DSS	174	
Primestar	178	
To reset to default code, enter 000		

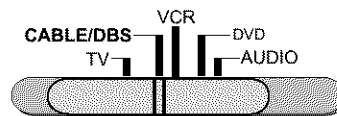

IMPORTANT

When set to TV, the PLAY, STOP, REW/REV and the FF/FWD keys will operate the VCR after the VCR codes have been chosen.

VCR codes:

VCR brand	code to enter:	If your VCR code is not listed here, please see page 64 for a complete listing.
Mitsubishi	001, 002	
Hitachi	020, 043, 065	
JVC	030, 054, 059	
Philips/Magnavox	043, 044, 051	
Panasonic	041, 042, 043	
RCA	020, 053, 065	
Sony	048, 049, 050	
Toshiba	021, 066	
To reset to default code, enter 000		

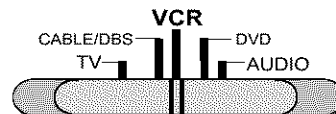

Remote Control of Other Audio and Video Product, continued

DVD Player codes:

DVD/LDP brand	code to enter:	If your DVD code is not listed here, please see page 63 for a complete listing.
Mitsubishi (DVD)	003	
Mitsubishi (LDP)	016, 017	
Panasonic	250	
Pioneer DVD (LDP)	252 (016, 017)	
Sony	254	
Toshiba	253	
To reset to default code, enter 000		

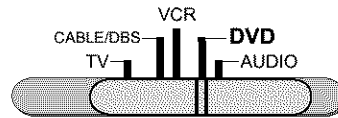

AV Receiver codes:

Audio brand	code to enter:	If your Audio code is not listed here, please see page 63 for a complete listing.
Mitsubishi AV receiver	010, 011, 012	
Mitsubishi CD player	013, 014, 015	
Kenwood	200, 208	
Onkyo	209, 214	
Pioneer	205, 207	
Sony	222	
Yamaha	201, 202	
To reset to default code, enter 000		

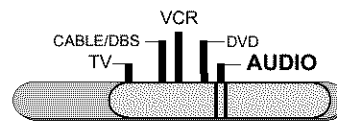

IMPORTANT

If the slide switch is set to TV when you enter an AV receiver code, VOLUME and MUTE will be controlled by the AV receiver.

Additional slide switch feature: -for multiple A/V component systems

Your Mitsubishi remote control was designed for flexibility in both large and small A/V systems. For example, you can use the slide switch in the following way:

If you have two VCR's, but no DVD player, move the slide switch to the DVD position and enter the second VCR code. Then when the slide switch is moved to DVD you can control the second VCR.

The following chart shows which device can be entered for each position. Only one device is allowed for each slide switch position.

TV position: <ul style="list-style-type: none"> • TV • any A/V receiver (volume, mute only) 	Cable/DBS position: <ul style="list-style-type: none"> • cable box • satellite receiver 	DVD position: <ul style="list-style-type: none"> • any DVD • any VCR • cable box
VCR position: <ul style="list-style-type: none"> • any VCR • Mitsubishi DVD player 	Audio position: <ul style="list-style-type: none"> • any AV receiver • Mitsubishi CD player • cable box 	

IMPORTANT

Some manufacturers may change their products, or they may use more than one remote control system. If this is the case, your remote may not be able to operate your VCR, Cable Box, Satellite Receiver or AV Receiver.

Remote Control Functions

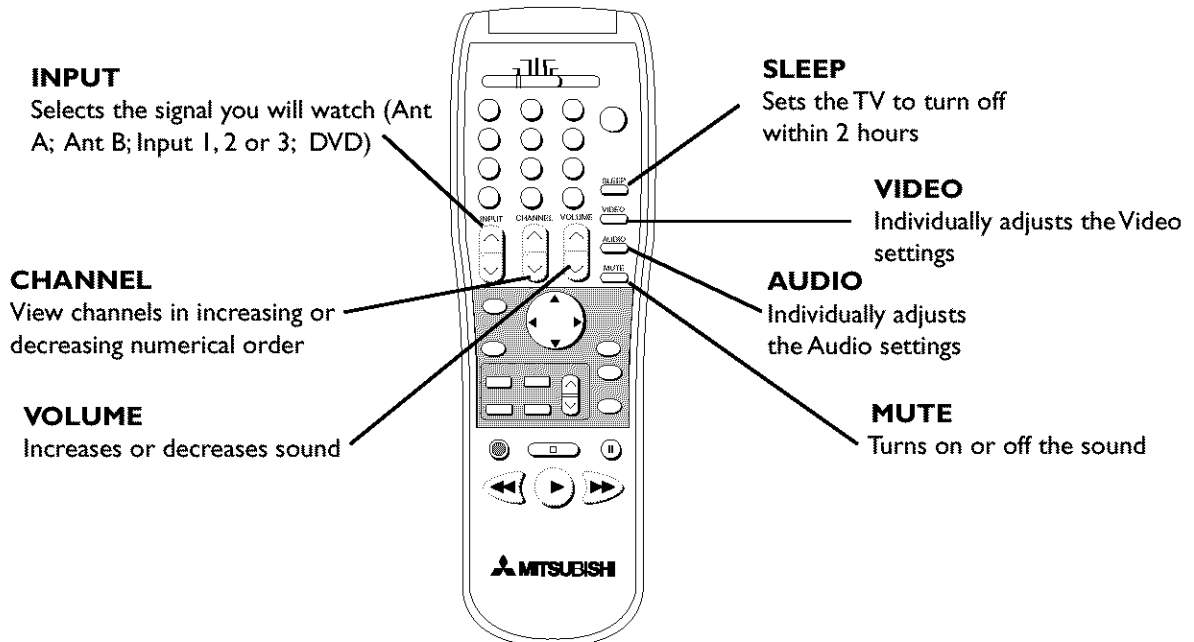
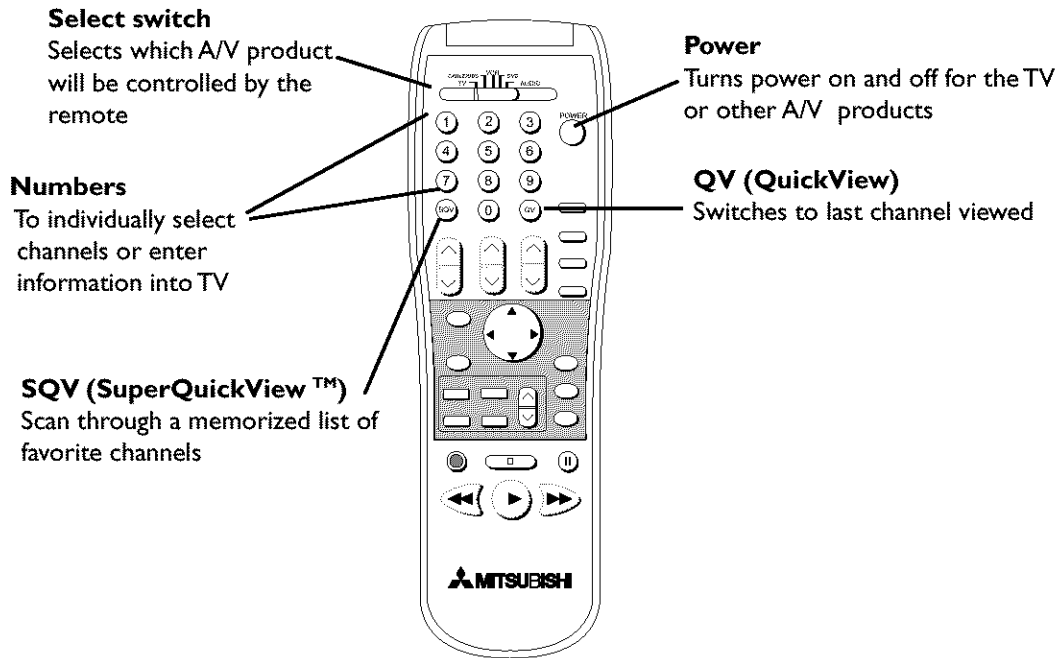

Remote Control Functions, continued

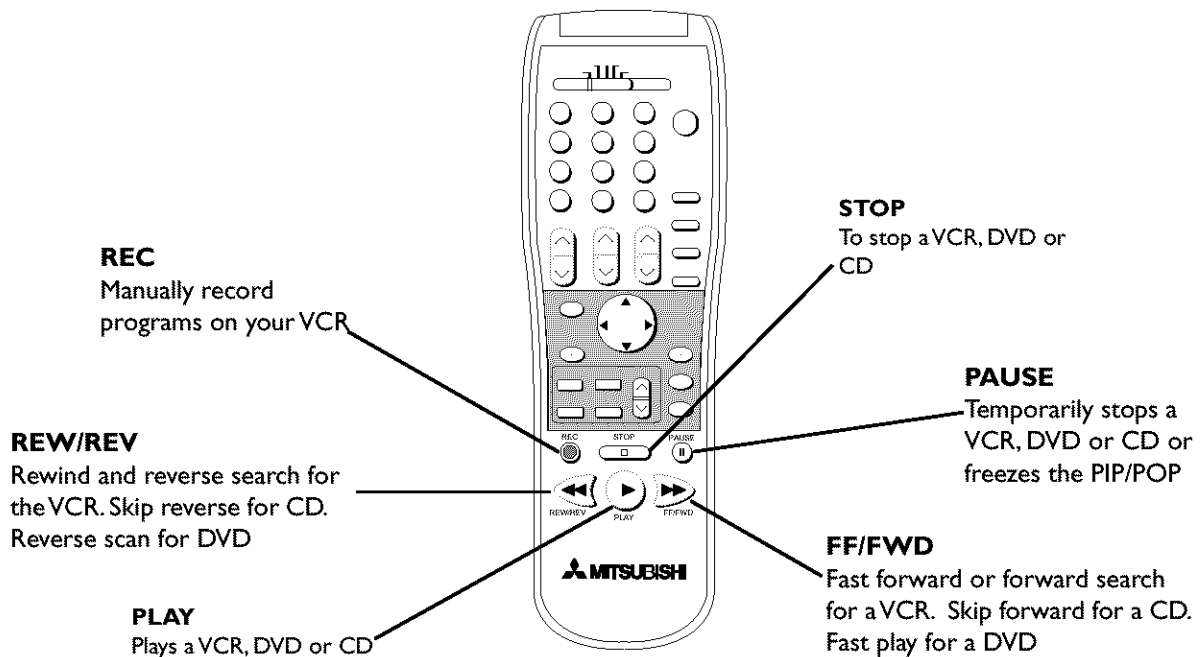
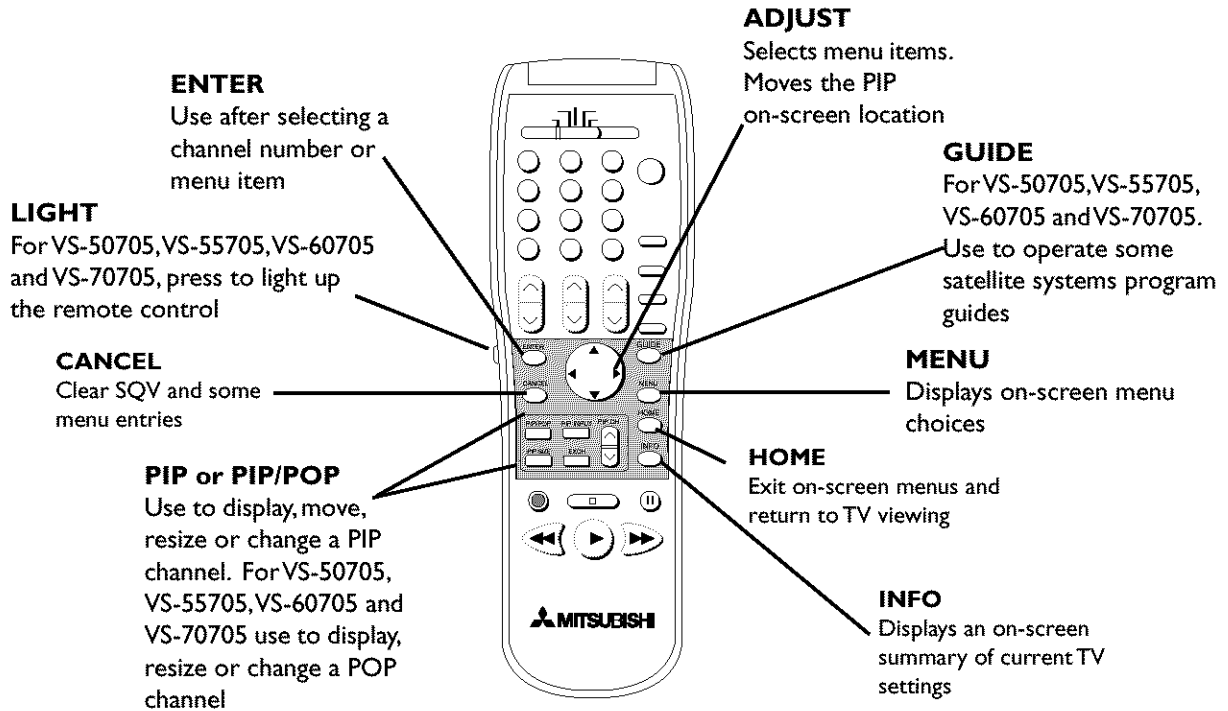

The ViewPoint® Menu System

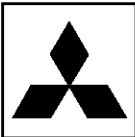

Your television has Mitsubishi's exclusive **ViewPoint®** on screen operating system, which provides on-screen information for menu choices and changes.

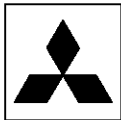

A highlighted **icon** is shown when there is another menu level for your choices. Pressing the **ENTER** button will display the menu options.

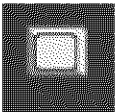

Make choices or changes to a menu item when you see a **button**.

1. MAIN MENU

SETUP
V-CHIP PARENT LOCK
CHANNEL EDIT
ADVANCED FEATURES
AUDIO/VIDEO SETTINGS

ADJUST to select or change option ENTER for menu MENU to return

The ViewPoint system includes the following special features:

- The selected icon or button is highlighted with a yellow outline and the text color will be yellow.
- On-screen instructions provide complete menu choice information.
- Some on-screen menu options must be set before other options are available. For example, "Set the Timer" will only be possible if "Clock Time" and "Set Day" have been set.

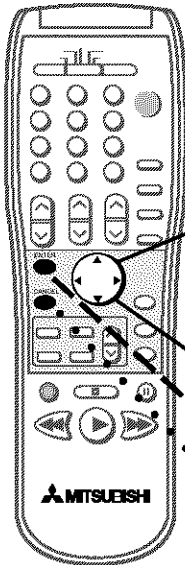

Making Selections:

- ADJUST ▲ or ▼ to select the menu item you want to change
- ADJUST ► to move to the selection field
- ADJUST ▲ or ▼ to change the settings
- ADJUST ◀ to move back to the menu item
- ENTER to select an option, or start an automatic function
- CANCEL to clear a setting, or stop an automatic function

To exit the on-screen menus:

Press the MENU key to move back one menu screen at a time until you exit all the menus to return to television viewing

OR

Press HOME to exit all menus with one keystroke and return to television viewing

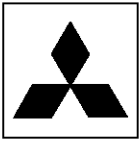

Menu Screens



Main Menu

The Main Menu Screen will always be the first screen that appears when you press the  button.

1. MAIN MENU

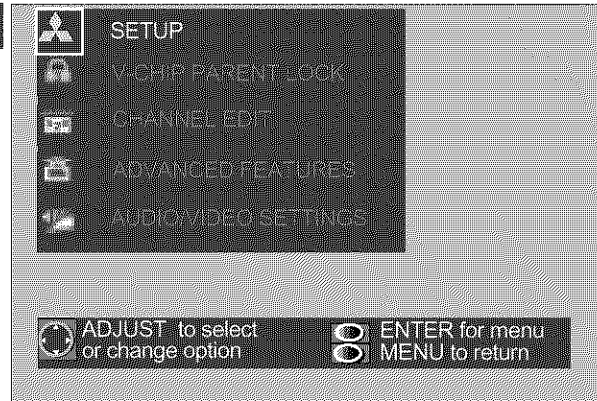

SET UP Menu

Basic set up instructions are available through the **SETUP** menu screens. You can put channels in memory, set the time and day for the TV, set your TV to be part of a Home Theater setting and view the menus in English or Spanish.

1. MAIN MENU 2. SETUP MENU



Menu Screens, continued

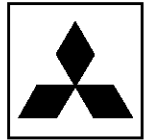

V-Chip Parent Lock Menu

- 1. MAIN MENU
- 2. V-CHIP PASSCODE
- 3. V-CHIP PARENT LOCK

The optional, built-in V-chip allows you to lock out programs, based on ratings. The TV can be locked during a specific time period. Locked programs can be viewed after entering a 4 digit passcode of your choice.

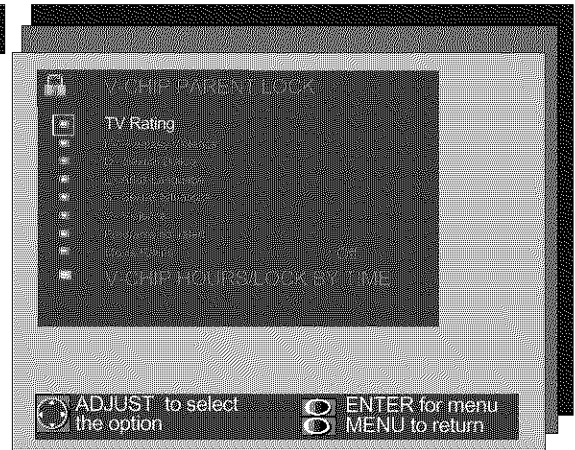

Channel Edit Menu

- 1. MAIN MENU
- 2. CHANNEL EDIT MENU

Use to select the input you want to watch, add or delete channels from memory, name channels or inputs and add your favorite channels to the SuperQuickView™ list.

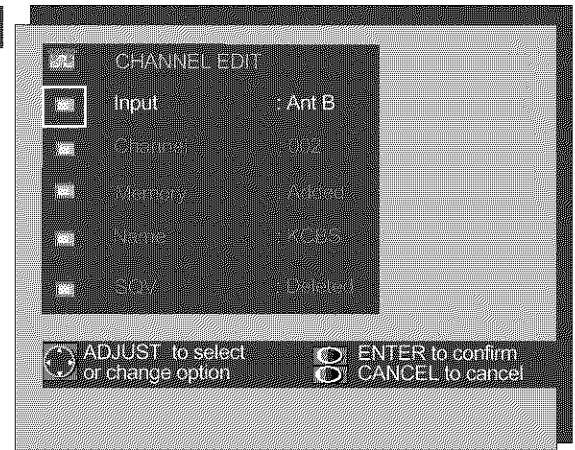

The Advanced Features Menu

- 1. MAIN MENU
- 2. ADVANCED FEATURES MENU

These screens let you set your TV to display captions or text, turn on automatically, display a blue screen when showing an input with no signal or align (converge) the three main colors.

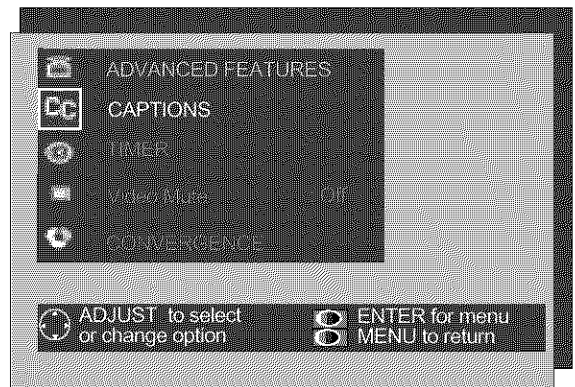

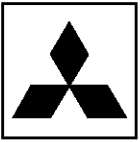

Menu Screens, continued



The Audio/Video Settings Menu

1. MAIN MENU

2. AUDIO/VIDEO SETTINGS MENU

You can individually adjust some or all of the audio and video settings. The five A/V Memory settings: Standard, Daylight, Evening, Home Theater and DVD, have been preset for the best picture and sound for specific room environments. AV Reset allows you to return the audio and video settings to the factory presets.

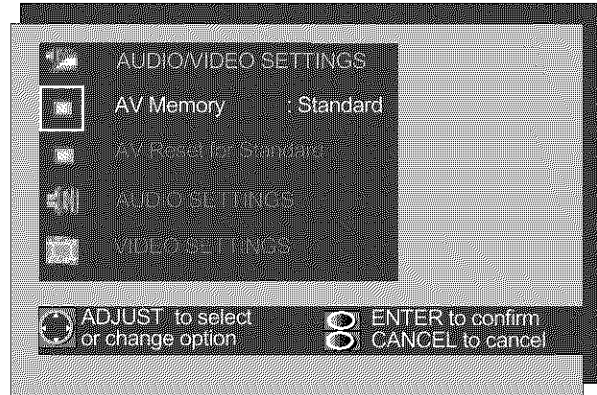

SETUP Menu

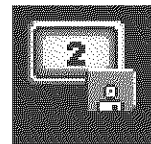

Memorizing Channels

1. MAIN MENU
2. SETUP MENU

This selection memorizes the channels your TV can receive and skips the unused channels. When memorization is complete, channels can be scanned using the remote control.



1. Press **MENU** to display the Main Menu. Use **▲** or **▼** to select the SETUP menu. Press **ENTER**.
2. Press **▲** or **▼** to select **Memorize Channels**. Press **▶** to move to the setting field. Press **▲** or **▼** to select the input you want to memorize. The available inputs are:

INPUT	CHANNELS THAT CAN BE MEMORIZED
ANTENNA A AIR	2 through 69
ANTENNA B AIR	2 through 69
ANTENNA A CABLE	1 through 125
ANTENNA B CABLE	1 through 125

3. Press **ENTER** to start the memorization. Added channels will be labeled "In Memory". Channels with poor or no reception will be labeled "Not in memory".
4. After memorization is complete, the screen will automatically return to the Setup menu. To exit, press **MENU** to return to **Main Menu**. Or, press **HOME** to return to television viewing.

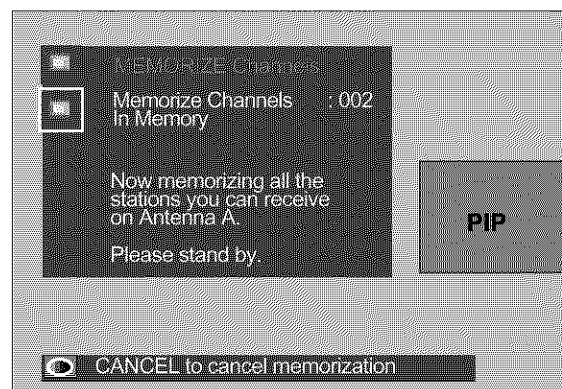

- You can stop the memorization at any time by pressing **CANCEL**. Channels memorized before stopping will stay in memory.

After channels are memorized, your remote control will:

- Select channels in ascending or descending order using **CHANNEL**.
- Select individual channels using the number buttons.

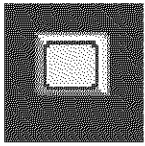

SETUP Menu, continued



Set Clock:

To set the current time.

1. MAIN MENU
2. SETUP MENU

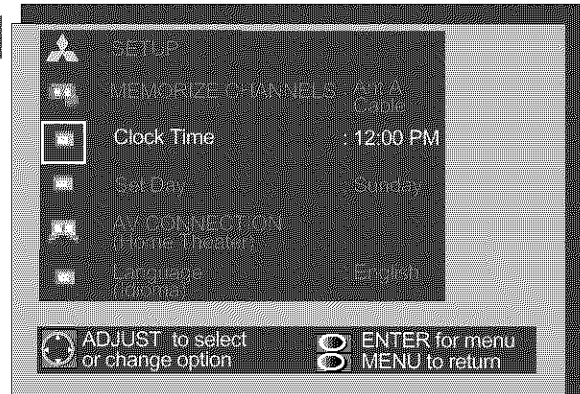













Set Day:

To set the current day.

1. MAIN MENU
2. SETUP MENU



1. Press  to display the Main Menu. Press  or  to select the SETUP menu. Press .
2. Press  or  to select **Clock Time** or **Set Day**. Press  to move to the setting field. Press  or  to select the correct time or day.
3. Press  after making your choice.
4. To exit, press  to return to the previous menu or  to return to television viewing.

SETUP Menu, continued

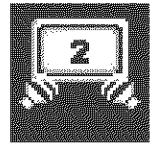

















The AV Connection Menu

The AV Connection Menu allows you to customize the way your TV works with other audio and video components, for a complete Home Theater experience.

Making Menu Selections for the AV Connection Menu:

1. MAIN MENU
2. SETUP MENU

1. Press  to display the **Main Menu**. Press  or  to select the **SETUP** menu. Press .
2. Press  or  to select **AV Connection Menu**. Press .
3. Press  or  to select the menu option to change. Your choices are:
 - AV Network** (Active or Off),
 - TV Speakers** (On or Off),
 - AV Receiver at Input 1** (Yes or No) and
 - Audio Output** (Variable or Fixed).(explanations for each of these features are found on pages 28 and 29)
Press  to move to the setting field.
4. Press  or  to change the setting for the selected option. Press  after making your choice. To select another menu option, press  or .
5. To exit, press  to return to the previous menu or  to return to television viewing.

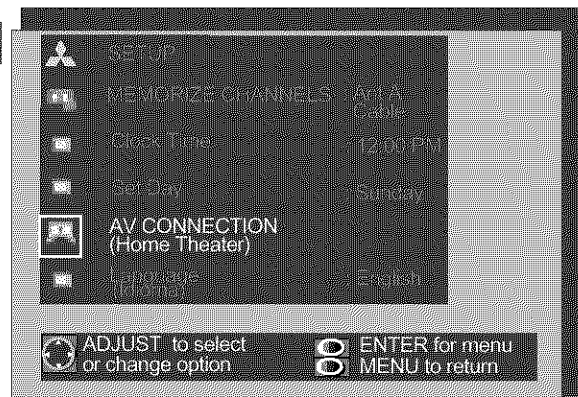

IMPORTANT

Set the **AV Network** to **Off**, if you are not using the **AV Network System**, for channel selection to work correctly.



The AV Connection Menu, continued

1. MAIN MENU
2. SETUP MENU
3. AV CONNECTION MENU

The AV Network

For use with compatible Mitsubishi AV Network or ACTIVE AV Network A/V products. With an Active AV Network compatible VCR, some TV and VCR functions can be simplified to just a few presses of the remote control buttons. With an AV Network compatible VCR, you can set the AV Network to Off and still pass the remote control signal from the TV to the VCR. For a detailed explanation of Active AV Network, see page 53. See the chart on page 30 to determine the correct settings.

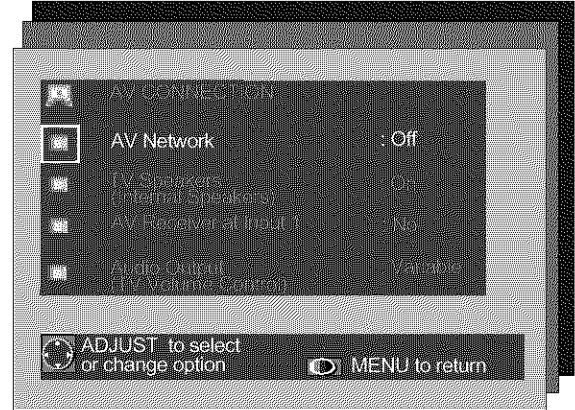

TV Speakers

1. MAIN MENU
2. SETUP MENU
3. AV CONNECTION MENU

This selection will turn on or off the TV's built-in speakers. You may select Off when sending the sound through a separate stereo system or surround sound AV receiver. See the chart on page 30 to determine the correct settings.

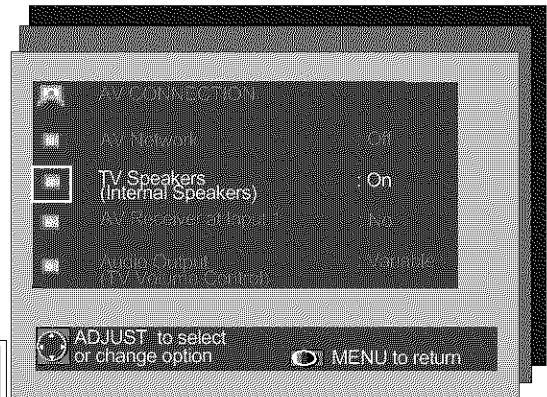

IMPORTANT

Changing the TV Speakers from OFF to ON will cause the TV speakers to turn on. To prevent damaging the TV speakers from a sudden increase in volume, make sure the TV volume is turned down before choosing ON.



AV Receiver at Input 1

1. MAIN MENU
2. SETUP MENU
3. AV CONNECTION MENU

Set to Yes when you connect an AV Receiver's video output to the TV's INPUT 1 to prevent a possible "feed-back" loop when changing the input selection of the AV Receiver. See the chart on page 30 to determine the correct settings.

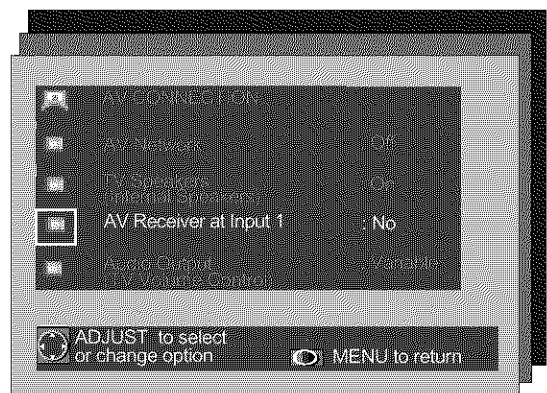

The AV Connection Menu, continued

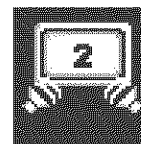

Audio Output

1. MAIN MENU
2. SETUP MENU
3. AV CONNECTION MENU

Select **Fixed** if your Audio Receiver or Stereo System has a remote control. This allows you to adjust the volume with that remote. Select **Variable** if your Audio Receiver or Stereo System does not have a remote. This allows you to use the TV remote to adjust the volume. See the chart on page 30 to determine the correct settings.

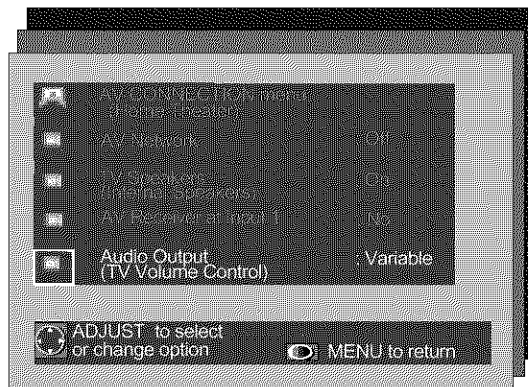

Selecting the Menu Language

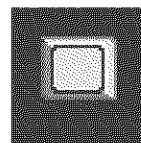

Changing the On-Screen Language

1. MAIN MENU
2. SETUP MENU

Use to display the on-screen menus in either English or Spanish (Español). The first time your television was powered on, you were requested to select an on-screen menu language. If the current selection is correct, you do not need to change it.

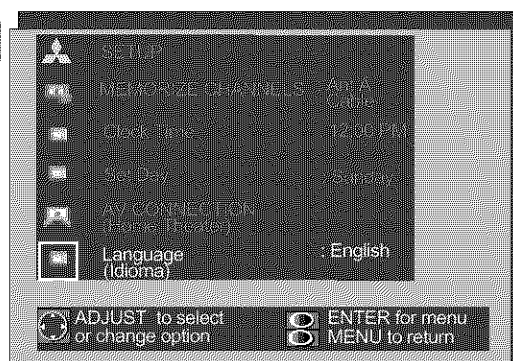



The AV Connection Chart

Setting choices vary depending on which components are connected to the TV. Below is a chart of common combinations and their recommended settings.

Equipment Connected	TV connection used	TV Feature Setting			
		Active AV Network	TV Speakers	AV Receiver at Input 1	Audio Output
VCR without • Active AV Network	VCR Output to: TV Input 1.	Off	On	No	Fixed or Variable
VCR with • Active AV Network, • non-remote controlled receiver or stereo system	VCR Output to: TV Input 1. TV Audio Outputs to: stereo system inputs.	Active <i>(also set VCR AV Network to On)</i>	Off	No	Variable
VCR with • Active AV Network, • remote controlled receiver or stereo system	VCR Output to: TV Input 1. TV Audio Outputs to: stereo system inputs.	Active <i>(also set VCR AV Network to On)</i>	Off	No	Fixed <i>(use the remote for the AV receiver or stereo to control the volume)</i>
Home Theater AV receiver with • remote, • any VCR • and any other AV equipment	TV Audio outputs to the AV receiver inputs. AV receiver monitor video output to TV Input 1. All other AV equipment outputs to AV receiver inputs.	Off	Off	Yes	Fixed <i>(use the remote for the AV receiver to control the volume)</i>
Home Theater AV receiver with • remote, • any VCR • and any other AV equipment using a combination of video and S-Video cables.	TV Audio & Video outputs to the AV receiver inputs. AV receiver monitor video and S-Video output to TV Inputs 1 and 2. All other AV equipment outputs to AV receiver inputs.	Off	Off	Yes	Fixed <i>(use the remote for the AV receiver to control the volume)</i>

IMPORTANT

See page 53 for more detailed information regarding the AV Network

Remote Control Input and Channel Selection

Input Source Selection

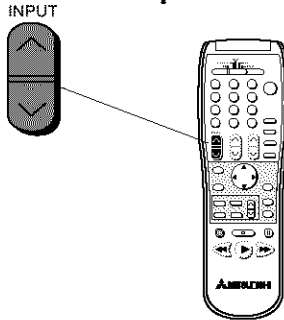

If you want to view a picture from your DVD, VCR, camcorder or laser disc player, you need to select the input the product is connected to. Use the input button on the front panel or the remote control INPUT button.

After selection, the input name will display briefly in the upper left corner of the screen.

Your input source can be:

- ANT A or ANT B - for antenna or cable systems signals.
- INPUT 1 or INPUT 2 - for audio video product connected to the TV back panel terminals.
- INPUT 3 - for audio video product connected to the TV front panel terminals.
- DVD - for component (Y, Cr, Cb) DVD players.

Changing Channels

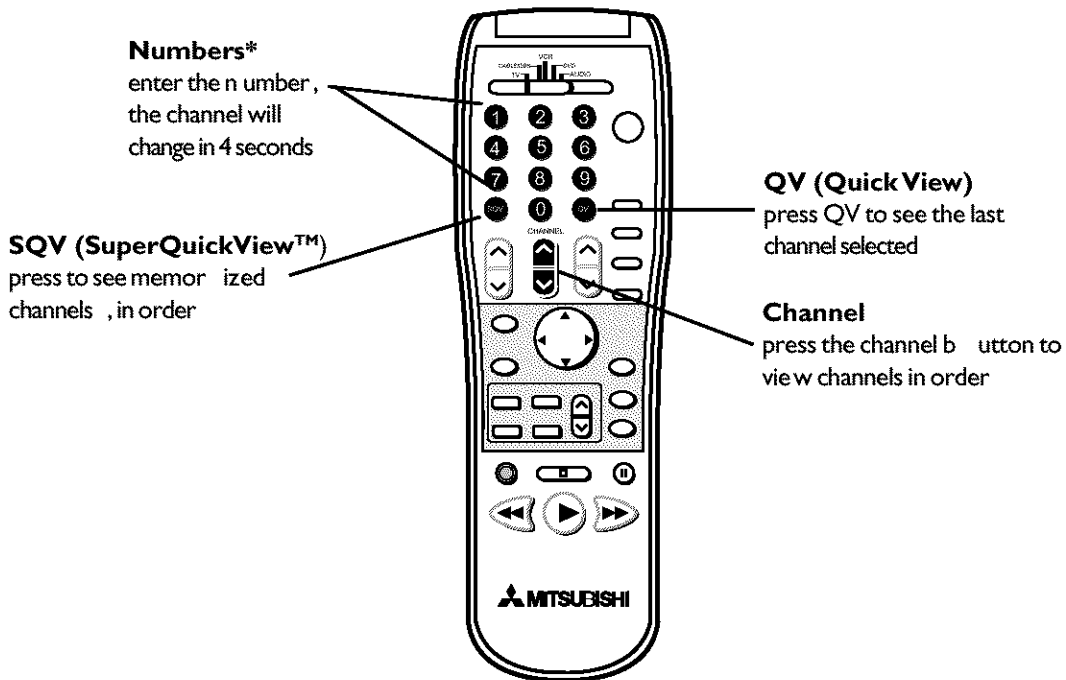

Numbers*
enter the number, the channel will change in 4 seconds

SQV (SuperQuickView™)
press to see memorized channels, in order

QV (Quick View)
press QV to see the last channel selected

Channel
press the channel button to view channels in order

- *When changing channels directly, you can change them faster by:
1. entering three numbers; for channel 2, press **002**
- OR**
2. press number and ENTER; for channel 2, press 2 then 

Remote Control for the Sleep Timer

Setting the Sleep Timer

Press  on the remote control. The TV will display the message:

Sleep: 030 Min.

With each press of  the time increases in 30 minute intervals until the maximum of 120 minutes is displayed.

Release  when the desired time is set.

To see how much time is left until the timer goes off, press  once. The remaining time will display on-screen.

Canceling the Sleep Timer

Press  to see the on-screen display.

Press  until you see the message:

Sleep: OFF

The timer will be canceled.

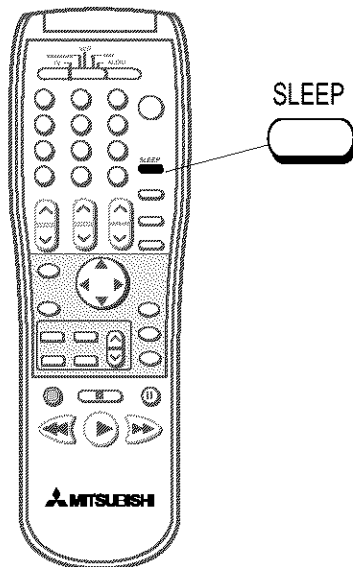

The Main Menu Screens



The V-Chip Parent Lock



Setting the V-Chip Parent Lock

1. MAIN MENU

You can use the V-Chip Parent Lock to Block or Allow programs based on the ratings sent by the broadcast stations. The default setting is to allow all programs. You can block programs by the type of program and by the categories you want blocked. Or you can block all programs during a specific time period. To use the V-Chip Parent lock, you will:

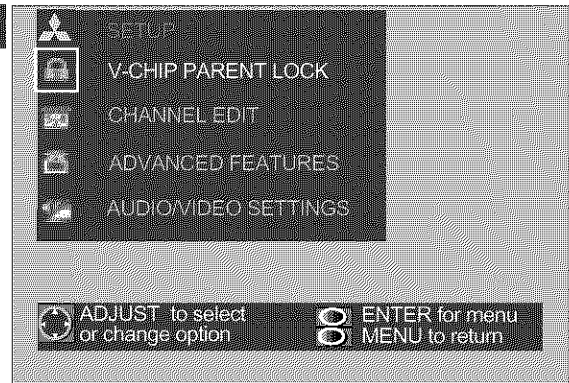

- Enter a passcode
- Select the V-chip ratings and categories to block
- Select the V-chip hours to lock and unlock for television programs
- Select lock by time

Enter a Passcode

1. MAIN MENU

2. V-CHIP PASSCODE

1. Press to display the Main Menu.
2. Press or to select **V-Chip Parent Lock**. Press .
3. Using the number keys, enter four numbers. To delete a character and move back one space, press . Press to set the passcode and go to the V-chip ratings menu.
4. To exit **without** entering a passcode, press to go to the previous menu or to return to television viewing.

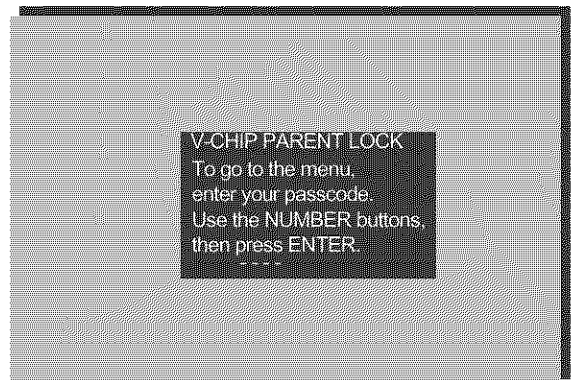

IMPORTANT

If you forget your four-digit passcode, please see Appendix 3 : Procedure for Bypassing the Parent Lock.



The V-Chip Parent Lock, continued



V-Chip ratings and categories

Rating guidelines are provided by broadcast stations. Most television programs and television movies can be blocked by TV Rating and/or Individual Categories. Movies that have been shown at theaters or direct-to-video movies use the Movie Rating system only.

Ant-A 011 KTTV
Stereo SAP
TV-PG DSLV

For Television Programs including made-for-television movies:

TV Ratings:

- OFF
 - TV-Y (youth)(individual categories do not apply)
 - TV-Y7 (youth, 7 years and up)
 - TV-G (general audience)(individual categories do not apply)
 - TV-PG (parental guidance suggested)
 - TV-14 (14 years and up)
 - TV-MA (mature audience)
- If you set the TV rating for **TV-PG**; TV-Y,TV-Y7,TV-G and TV-PG will be available. TV-14 and TV-MA will be blocked.

Individual Categories (cannot use with TV-Y and TV-G):

- FV - Fantasy Violence (only applies to TV-Y7)
- D - Sexual Dialogue (applies to TV-PG and TV-14)
- L - Adult Language (applies to TV-PG,TV-14 and TV-MA)
- S - Sexual Situations (applies to TV-PG,TV-14 and TV-MA)
- V - Violence (applies to TV-PG,TV-14 and TV-MA)
- Programs not rated: Programs that have not received a rating, such as sports, news or other programs where a rating could not be given.

For Movies previously shown in theaters or Direct-to-Video*:

Movie Rating:

- Off
- G (general audience)
- PG (parental guidance suggested)
- PG-13 (13 years and up)
- R (restricted)
- NC-17 (18 years and up)
- X (adult)

If you set the lock for **PG-13**; G, PG and PG-13 will be available. R, N-17 and X will be blocked.

*Video tapes, laser discs or DVD's may not contain the special V-Chip rating signals. If this occurs, the V-Chip lock cannot be used to block these movies.



The V-Chip Parent Lock, continued



Select Lock by Time

1. MAIN MENU
2. V-CHIP PASSCODE
3. V-CHIP PARENT LOCK
4. V-CHIP HOURS/LOCK TIME

You may lock **all** TV viewing for a set time period. To view programs during the locked time, enter your four-digit passcode.

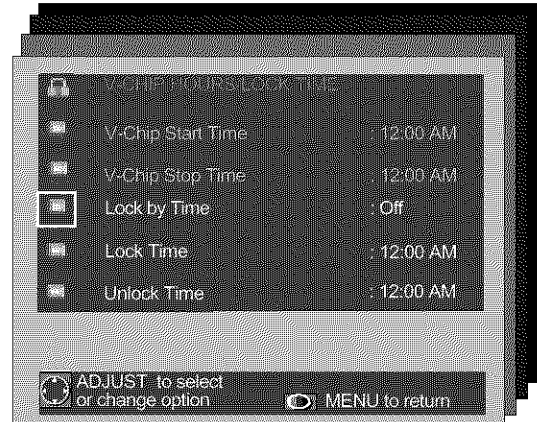

To lock the TV:

1. After entering your passcode, press **▲** or **▼** to select V-Chip Hours/Lock Time and press **ENTER**.
2. Press **▲** or **▼** to select Lock by Time. Press **▶** to move to the setting field and use **▲** or **▼** to choose On. Press **◀** after making your choice.
3. Press **▲** or **▼** to select Lock Time. Press **◀** after making your choice. Select Unlock by Time the same way.
4. To exit, press **MENU** to go to the previous menu or **HOME** to return to television viewing.
5. To view the TV during the locked time, enter your passcode, when it is requested.
6. To reset the TV lock, turn off the TV.

IMPORTANT

1. If Lock Time and Unlock Time are set to the same time, the Parent Lock will be on 24 hours a day.
2. If Lock Time is On and Lock Time and Unlock Time are not set, the Parent Lock will be on 24 hours a day.

The Channel Edit Menu

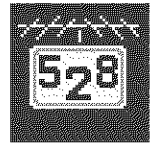

Using the Channel Edit Menu

1. MAIN MENU
2. ADVANCED FEATURES MENU
3. CAPTIONS MENU

- Add or Delete Channels
- Select Names for Channels
- Select Preset Names for Inputs
- Select SuperQuickView™ Channels

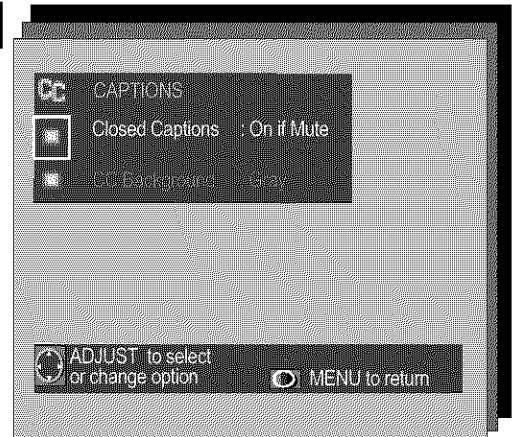

To use edit channel features:

1. Press to display the Main Menu. Press or to select the CHANNEL EDIT menu. Press .
2. Press or to select the menu option you want to change. Press to move to the setting field. Press or to change the selection.
3. Press after making your choice.
4. To exit, press to return to the previous menu or to return to television viewing.



Adding and Deleting Channels

1. MAIN MENU
2. CHANNEL EDIT MENU

After all available channels have been memorized with the “Memorize Channels” feature, weaker channels viewed with Ant A or Ant B can be added back in or unwanted channels can be deleted, on an individual basis.

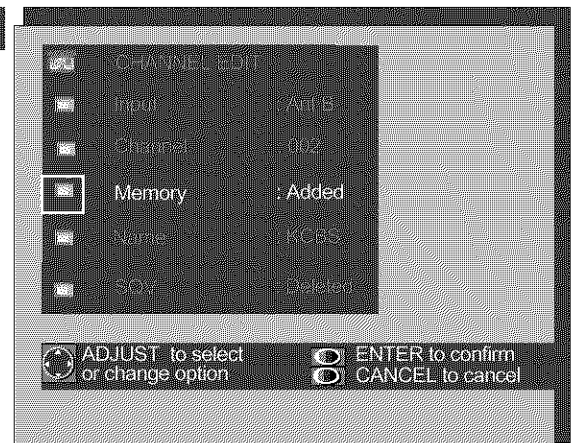



The Channel Edit Menu, continued



Selecting Names for Channels

- 1. MAIN MENU
- 2. CHANNEL EDIT MENU

You can personally name the channels your TV receives on the INPUT Antenna A or B, up to a maximum of four characters. After you enter a name, it will appear on screen, next to the channel number. Select Ant A or B for INPUT. Select the memorized CHANNEL you want to name.

At the NAME field, you can use letters (A-Z), numbers (0-9) and/or symbols (! . & ' / : * - , and blank). If you want to change your selection while in the option field, use CANCEL to delete the current character. This will move the cursor one position back. If you press CANCEL while at the first character, the entire name will be deleted.

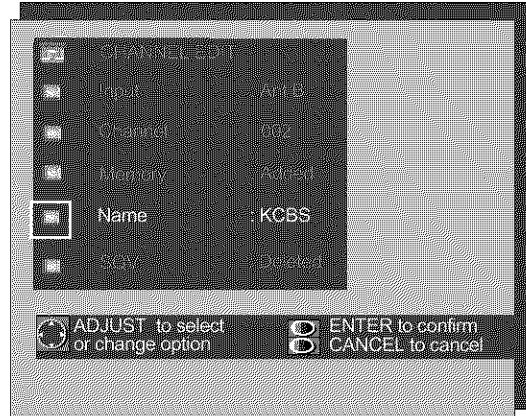

Selecting Preset Names for the Inputs

- 1. MAIN MENU
- 2. CHANNEL EDIT MENU

This feature allows you to keep track of components that are connected to your TV by selecting preset names for Inputs 1, 2, or 3. The new name will appear on the screen display when the inputs are selected. There are 15 names that you can choose from, they are: **VCR1**; **VCR2**; **DVD**; **LASER**; **SAT** (satellite); **CABLE**; **CAM** (camcorder); **GAME**; **VHS**; **S-VHS**; **DTV**; **WEB** (Internet set-top-box); **MAIN**; **AUX**; and **SURV** (surveillance or security).

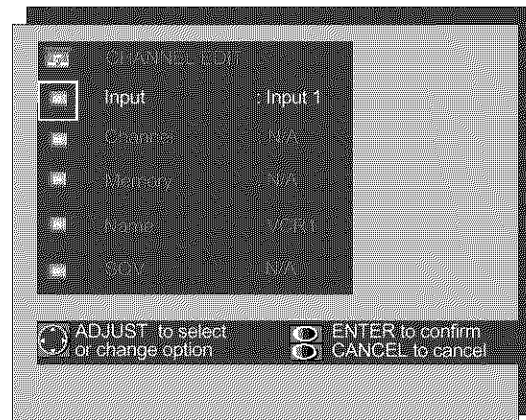

The Channel Edit Menu, continued

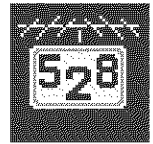

Selecting SuperQuickView™ Channels

- 1. MAIN MENU
- 2. CHANNEL EDIT MENU

SuperQuickView™ allows you to put together a list of your favorite channels. You can quickly look through the list using the SQV button.

Once you've added a channel to the SQV memory, the letters "SQV" appear under the channel number any time the channel number is displayed, even if you tune to the channel using another method.

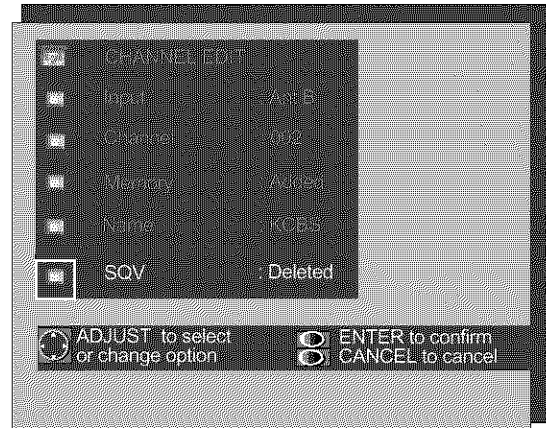

IMPORTANT

SQV memorizes channels from ANT A or ANT B only.

adding the SQV channels directly with the remote control

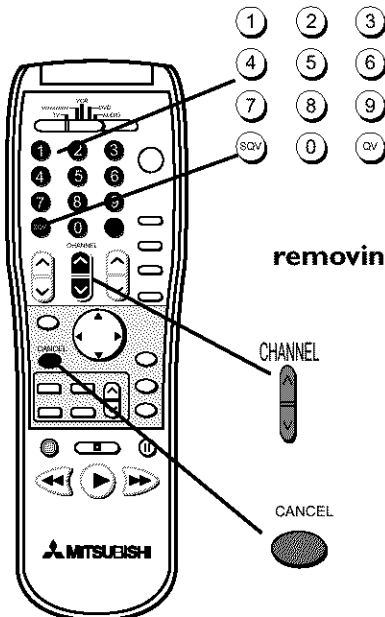

1. Use the CHANNEL button or number buttons to select the channel you want to add to the list.
2. Press and hold the SQV button for about 3 seconds. The letters "SQV" will appear under the channel number, indicating that the channel has been added to SuperQuickView™ memory.

removing SQV channels with the remote control

1. Press the SQV button repeatedly to select the channel to be removed from the list.
2. While the channel number and SQV indicators are still displayed on the screen, press the CANCEL button.
3. When the SQV indicator disappears, the channel has been canceled from the SuperQuickView list. If you wait until the channel and SQV indicators disappear automatically, then the CANCEL button will not remove the channel from the list.

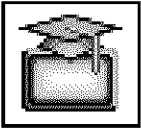

The Advanced Features Menu









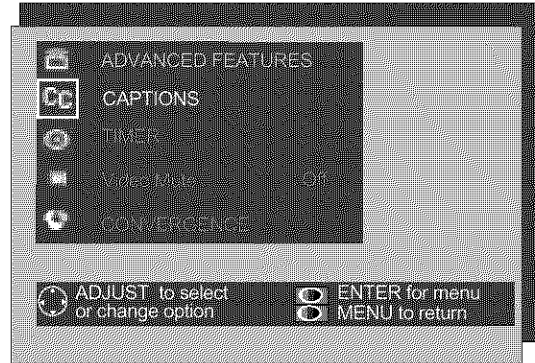





The Advanced Features Menu





1. MAIN MENU
2. ADVANCED FEATURES MENU



- Select Closed Captioning, page 41
- Select the Timer Option, page 42
- Select Video Mute, page 42
- Adjust the Convergence, pages 43-44



Using the Advanced Features Menu:

1. Press  to display the Main Menu. Press  or  to select the **ADVANCED FEATURES** menu. Press .
2. Press  or  to select the **ADVANCED FEATURES** menu options you want to change.
3. For CAPTIONS, TIMER or CONVERGENCE, press  to go to the selected menu. Then press  or  to select the option you want to set or change. Press  to move to the setting field and press  or  to change the setting. Press  after making your choice.

For Video Mute, press  to move to the setting field and press  or  to change the setting. Press  after making your choice.

4. To exit, press  to return to the previous menu or  to return to television viewing.

The Advanced Features Menu, continued



Select Closed Captioning

1. MAIN MENU

2. ADVANCED FEATURES MENU

3. CAPTIONS MENU

You can turn on or off the closed caption decoder screen. You can also choose black or gray as the background color for the closed caption area.

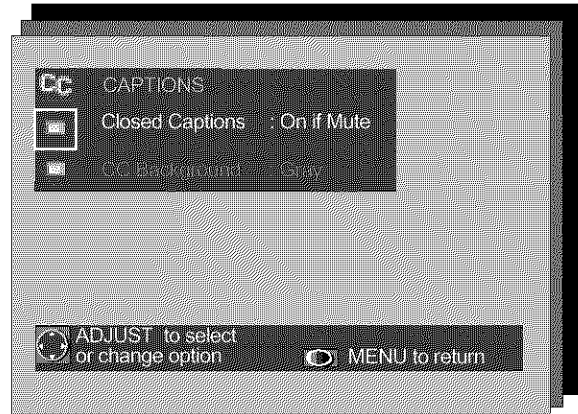

IMPORTANT

The content of captions are determined by the broadcaster. If your captions show strange characters, misspellings, or odd grammar, it is not a malfunction of the TV.

There are two types of captioning that broadcasters can send: standard and text.

Standard captioning follows the dialogue of the characters on-screen and displays in a small section of the screen when the broadcaster is sending the closed captioning.

Text captioning often contains information such as weather or news. Text captioning blocks a portion of the program that is on-screen.

Your TV can decode four different standard captioning signals and four different text captioning signals from each TV station. However, each station may broadcast only one or two captioning signals, or none at all.

When setting the decoder, you can choose to display:

- one of four standard captioning signals (CC1, CC2, CC3, CC4)
- one of four text captioning signals (Text 1, Text 2, Text 3, Text 4)
- captions when mute (On if mute)
- no captions when mute (Off)

If you select "On if mute," the standard captioning signal (CC1) will appear whenever you use the MUTE button. If you set the decoder to a "standard" caption setting or "On if mute" and tune to a broadcaster that is not sending a caption signal, no captions will appear.

IMPORTANT

A large black or gray box will appear on your TV screen, if you have selected text captioning, and no text signal is being broadcast.

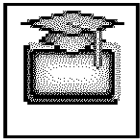

The Advanced Features Menu, continued



Select the Timer Option

1. MAIN MENU
2. ADVANCED FEATURES MENU
3. TIMER MENU

This special feature will automatically:
tune to a memorized channel on
ANT A, ANT B, INPUT 1, 2 or 3, or the
DVD at a specific time and;
turn the TV on, if it is off.

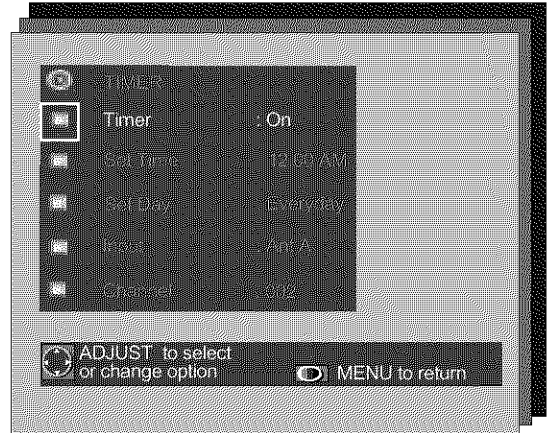

IMPORTANT

The TV's clock must be set before you can set the timer. If you haven't set the clock and/or day, you will see the **SETUP** Menu with **Set Time** selected instead of the **Timer** menu.

IMPORTANT

When the timer turns the TV on, the message "Press a key for TV to stay on" is shown. If you don't press a button on the remote control or front panel within 5 minutes, the TV will automatically turn off.



Select Video Mute

1. MAIN MENU
2. ADVANCED FEATURES MENU

Video Mute lets you display a blue screen when no signal is being received from Input 1, Input 2, Input 3 or DVD.



The Advanced Features Menu, continued

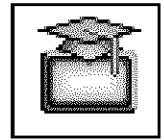

Convergence

1. MAIN MENU

2. ADVANCED FEATURES MENU

Your Mitsubishi Projection TV has three picture tubes with large diameter lenses which are aligned to project light beams on the screen. Each picture tube projects only one color: red, green or blue. During production, your television was carefully adjusted to properly align these colors.

As a special feature, you have the ability to adjust the color convergence, should you think that the red and/or blue light beams are out of alignment. The green beam acts as a fixed reference for aligning the red and blue beams.

Static Convergence aligns the whole screen at one time. Advanced convergence aligns 64 individual adjustment positions

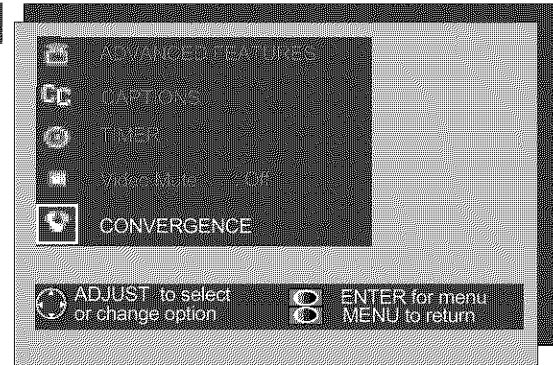

















Adjusting the Static Convergence:

1. MAIN MENU

2. ADVANCED FEATURES MENU

3. CONVERGENCE MENU

1. Press  to display the Main Menu.
2. Press  or  to select **Advanced Features**. Press .
3. Press  or  to select **Convergence**. Press .
4. Press  or  to select either Red or Blue Convergence. Press .
5. Press , , or  to align the color you selected with the fixed green lines. The vertical and horizontal lines will merge into a single white cross when aligned correctly.
6. Press  to switch between red and blue.
7. Press  to exit, or  to proceed to Advanced Convergence.

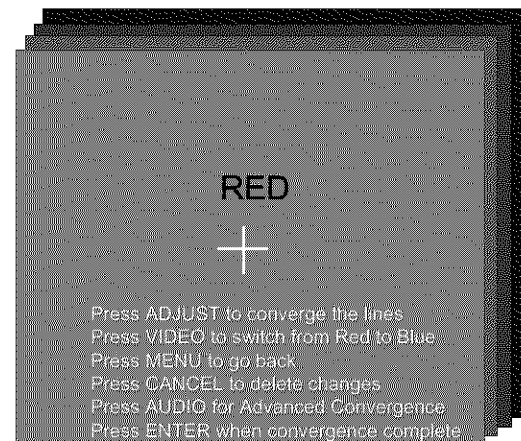
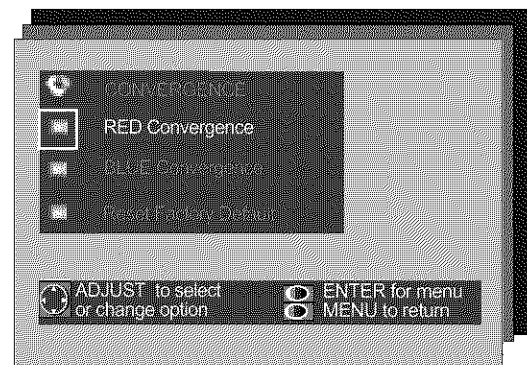



The Advanced Features Menu, continued



Advanced Convergence

1. MAIN MENU
2. ADVANCED FEATURES MENU
3. CONVERGENCE MENU
4. STATIC CONVERGENCE
5. ADVANCED CONVERGENCE

Before you can adjust the Advanced Convergence, you must adjust the Static Convergence for both Red and Blue.

1. Press **▲▶▼** or **◀** to move the flashing bracket to a position that needs adjustment. Press **ENTER** to stop the flashing.
2. Press **▲▶▼** or **◀** to move the red or blue line. A position is converged when all three lines combine to make a white line.
3. Press **ENTER** when aligned and the bracket will flash again. Repeat this process to align other positions.
4. Press **VIDEO** to alternate between red and blue.
5. To exit, press **MENU** to return to the previous menu or **HOME** to return to television viewing.

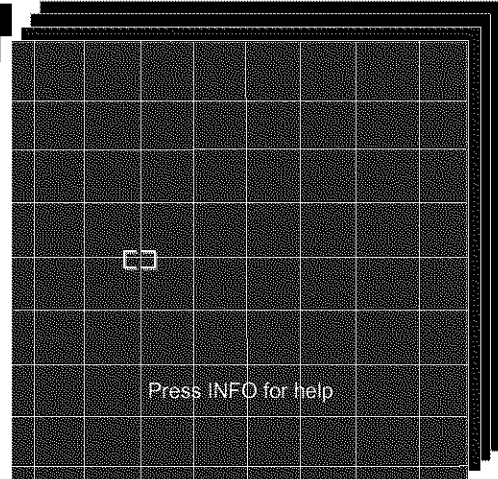

IMPORTANT

There are more than 64 line intersections. However, the bracket will only stop on the 64 adjustment positions.

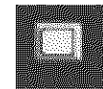

Resetting the Factory Defaults

1. MAIN MENU
2. ADVANCED FEATURES MENU
3. CONVERGENCE MENU

1. Press **MENU** to display the Main Menu.
2. Press **▲** or **▼** to select **Advanced Features**. Press **ENTER**.
3. Press **▲** or **▼** to select **Convergence**. Press **ENTER**.
4. Press **▲** or **▼** to select **Reset Factory Default**. Press **ENTER**. The message "Convergence reset completed" will display when the defaults are reset.
5. To exit, press **MENU** to return to the previous menu or **HOME** to return to television viewing.

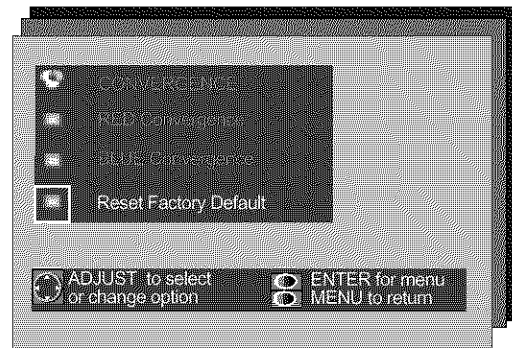

Audio/Video Settings Menu

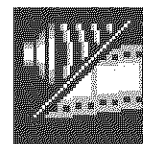

Adjusting the Audio and Video Settings

1. MAIN MENU
2. AUDIO/VIDEO SETTINGS MENU

The TV has five AV audio video memories. The memories are: **Standard, Daylight, Evening, Home Theater and DVD**. You can adjust the settings of each memory using the menus or you may adjust the settings of the currently used memory using the remote control.

AV Reset will return the setting of the currently selected memory to the original factory presets.

The memory for each input (Antenna A or B, Input 1, 2, 3 or DVD) is preset to Standard. You can select and adjust a different memory for each of the TV inputs, which will be recalled each time that input is selected.

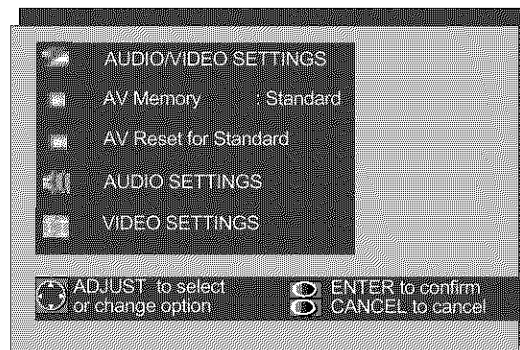

Using the AUDIO or VIDEO button on the remote control

1. Press **AUDIO** or **VIDEO** repeatedly until the desired setting displays at the bottom of the screen.
2. Press **◀** or **▶** to change the setting. In 5 seconds the display will disappear.

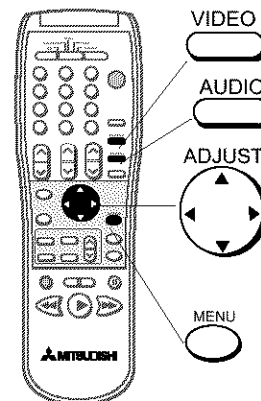

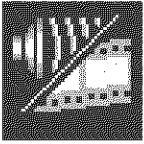

Audio/Video Settings Menu, continued



AV Memory Menu Settings

1. MAIN MENU
2. AUDIO/VIDEO SETTINGS MENU

1. Press **INPUT** on the remote to select the desired input to change.
2. Press **MENU** to display the Main Menu.
3. Press **▲** or **▼** to select **AUDIO/VIDEO SETTINGS**. Press **ENTER**.
4. Press **▲** or **▼** to select **AV Memory**.
5. Press **▶** to move to the setting field. Press **▲** or **▼** to select the AV Memory to change. Press **◀** after making your choice.
6. Press **▲** or **▼** to select **AUDIO SETTINGS** or **VIDEO SETTINGS**. Press **ENTER** to display the individual settings. Press **◀** or **▶** to change the setting.

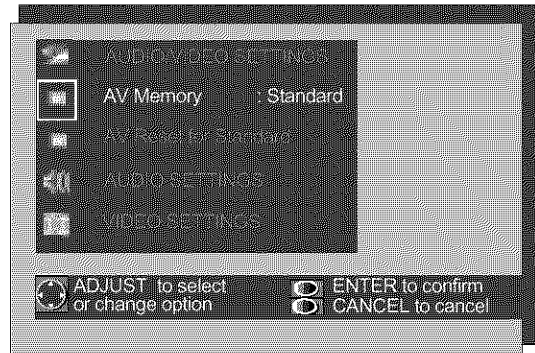

AV Reset

1. MAIN MENU
2. AUDIO/VIDEO SETTINGS MENU

1. Select the **AV Memory** to reset.
2. Press **▲** or **▼** to select **AV Reset**.
3. Press **ENTER** to return to the currently selected memory's factory default settings.
4. Press **MENU** to return to the previous menu or **HOME** to return to television viewing.

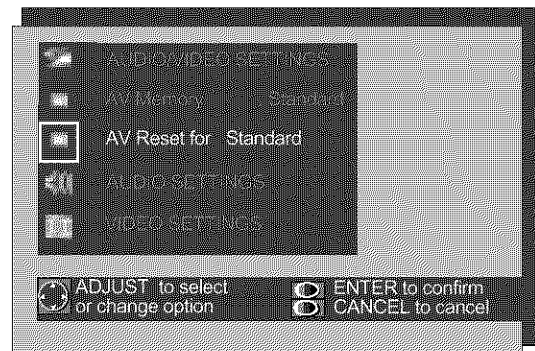

Audio/Video Settings Menu, continued

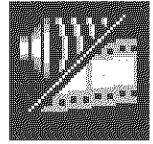

Adjusting the picture

Descriptions of video settings

IRIS™ is the Intelligent Room Illumination (light) Sensor. When IRIS is on, your TV will automatically adjust the picture contrast and brightness for the best picture based on your room lighting. Included on models VS-50705, VS-55705, VS-60705 and VS-70705.

Contrast provides a scale that controls the level of white-to-black in the picture. Low contrast will show a variety of shades in the darker images on the screen. High contrast will show the screen's dark images more uniformly black and make the colors on the screen seem more vibrant.

Brightness provides a scale that controls the overall brightness of the picture.

Sharpness provides a scale that adjusts the detail and clarity of the picture.

Tint provides a scale that adjusts the proportion of red to green in the picture.

Color provides a scale that determines the intensity of the color.

Color Temp (Color temperature) allows you to set how the TV will display white images. Your choices are "**Low 6500K**," "**High**," or "**Medium**."

- With the **Low 6500K** setting, white images on-screen will have a warm cast to them. This setting represents the 6500°K industry standard. This adjustment is an average and can vary due to ambient room lighting, video scene brightness and the TV's age.
- With the **High** setting, white images on-screen will have a cool cast to them. This setting may provide the most realistic picture under bright lighting.
- With the **Medium** setting, white images on-screen will be balanced between the Low (warm) and High (cool) settings.

Adjusting the sound

Descriptions of audio settings

Bass enhances or reduces low frequency sound.

Treble enhances or reduces high frequency sound

Balance adjusts the level of sound between the left and right speakers.

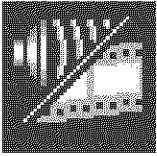

Audio/Video Settings Menu, continued

Adjusting the sound, continued

Surround creates simulated stereo and surround effects. You can set this setting to “**Off**,” “**Simulate**” or “**Surround**.” Select:

- **Off** when you do not want to use any surround effects. Set the surround setting to “OFF” when using an A/V receiver with Dolby® Pro Logic Surround, or Dolby Digital Surround.
- **Simulate** when you are watching a non-stereo program. Your TV will create a simulated stereo effect by using the TV’s speakers.
- **Surround** when you are watching a stereo program. Your TV’s internal speakers will create a simulated surround effect, making the sound seem to extend around and behind you.

Listen to determines how your TV will receive a broadcast audio signal and play back the sound that you hear. You can set this function to “**Stereo**,” “**S.A.P.**” or “**Mono**.”

- **Stereo** is the default setting. With this setting, the TV will play stereo broadcasts in stereo and mono broadcasts in mono. Stereo broadcasts will display the word “Stereo” when you tune to that channel.
- **S.A.P.** is an additional monaural soundtrack that you can’t hear during normal TV viewing. The S.A.P. signal might be related to the program you are watching, such as a soundtrack in a foreign language, or it might be unrelated such as a weather report. If the S.A.P. signal is broadcast, the letters “SAP” will appear on-screen when you tune to that channel. Choose “Listen to: SAP” to hear the S.A.P. signal.
- **Mono** will reduce background noise and should be used if you are receiving a weak stereo audio signal. The sound will be only in mono even if the program you are watching is in stereo.

Level Sound automatically equalizes the volume level of programs that contain significant sound level differences from one segment to another, for example; regular programming to commercials. To receive the best audio fidelity for music programs, you may want to turn this setting to Off.

“Dolby,” “AC-3,” “Pro Logic” and the double-D symbol are trademarks of Dolby Laboratories Licensing Corporation. Copyright 1992 Dolby Laboratories, Inc. All rights reserved.

Special Remote Control Functions

When your remote control has been programmed to operate other manufacturer's products the functions it performs on each layer will vary by manufacturer and model. The most common functions are:

VCR:

- POWER
- CHANNEL up/down
- REC
- STOP
- PAUSE
- REW/REV
- PLAY
- FF/FWD

Mitsubishi VCRs will be compatible with additional keys

Cable Boxes and Satellite Receivers:

- POWER
- CHANNEL up/down
- ENTER (on some models)
- ARROW up/down/left/right (on some models)
- 0-9 number keys (on some models)
- CANCEL (on some models)
- GUIDE (on some models)

AV Receivers:

- POWER
- VOLUME
- MUTE
- DIRECT INPUT SELECTION (on some Mitsubishi models)

MITSUBISHI CD Players

(when using audio code 010 or 011):

- PLAY
- FF
- REW
- PAUSE
- STOP

DVD and Laser Disc players

(not all functions for all models):

- POWER
- 0-9 numbers
- MENU
- CANCEL
- STOP
- PAUSE
- REW
- PLAY
- ARROW up/down/left/right

Special Remote Control Functions, continued

Picture in Picture Mode

For models VS-45605 and VS-50605, you can display a PIP (Picture-in-Picture) in one of two different sizes. For models VS-50705, VS-55705, VS-60705 or VS-70705 you can display a PIP in one of five sizes or you can display up to three POP's (Picture-outside-Picture). The PIP or POP can be shown in all inputs, except DVD.

The INPUT source

To see the PIP you need to select an input source. If the only input you have connected is ANT A, then both the main picture and PIP will both be from ANT A.

If you have connected other video products, you may be able to view the main picture and PIP images from different input sources. Please review the chart to see the possible combinations:

Main Picture:	PIP:					
	ANT A	ANT B	INPUT 1	INPUT 2	INPUT 3	DVD
ANT A	X		X	X	X	n/a
ANT B	X		X	X	X	n/a
INPUT 1	X	X		X	X	n/a
INPUT 2	X	X	X		X	n/a
INPUT 3	X	X	X	X		n/a

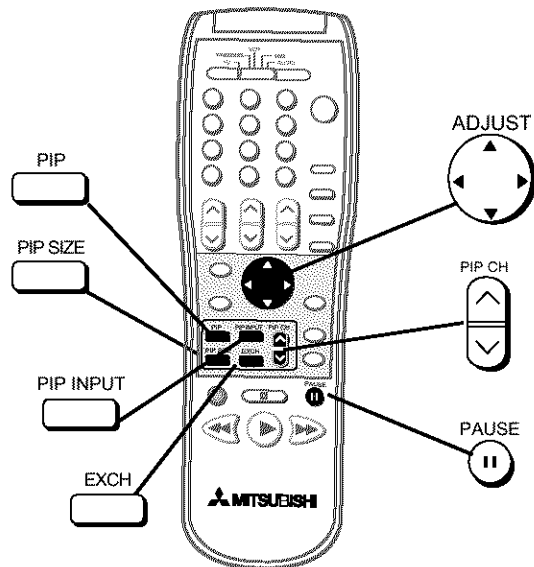

VS-45605 and VS-50605

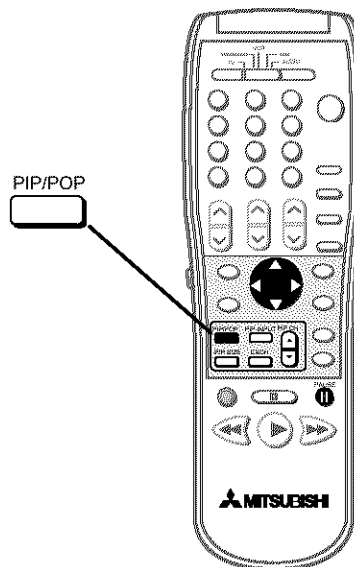



Additional Feature for:
VS-50705, VS-55705, VS-60705 and VS-70705

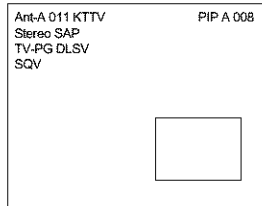

Special Remote Control Functions, continued

Selecting the INPUT source



1. To view a PIP image, press .
2. To see the available PIP inputs, press  repeatedly. The input name will be displayed on screen for about five seconds. Turn on the equipment connected to INPUT 1, 2 or 3 if you select one of these inputs as the PIP input source.

Changing the PIP channel when PIP input source is ANT A

1. Press .
2. Press  to show a different channel on the PIP.
3. Cancel the PIP by pressing  again.

Changing the PIP size

For models VS-45605 or VS-50605 you have a choice of two different PIP sizes.
For models VS-50705, VS-55705, VS-60705 or VS-70705 you have a choice of five PIP sizes.

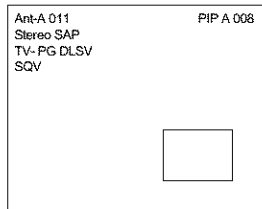

To change the PIP size, press . Each press will change the size.

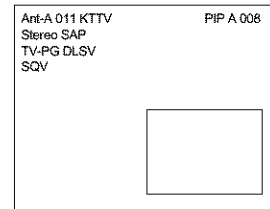

Moving the PIP image

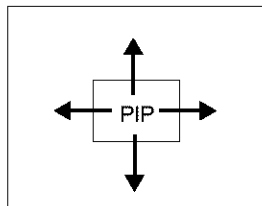

Press  to move the PIP image anywhere on the screen.

Freezing the PIP image

Verify that select switch is in the TV position.

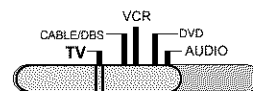

While viewing a PIP channel, press  to freeze the image.

Press  again to return to a live picture.

Remote Control of the PIP (Picture-in-Picture), continued

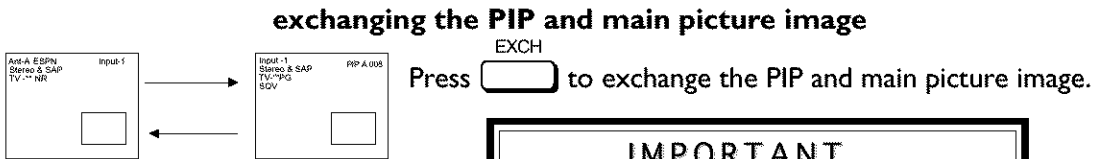

IMPORTANT

If the main picture is from ANT B and the PIP is from ANT A, a blank PIP will display when exchanged.

Displaying one or three POP (Picture-Outside-Picture) images for models VS-50705, VS-55705, VS-60705 and VS-70705

1. Press . You will see a PIP image. Press again to see one POP image. The POP channel will be different than the main TV picture channel.

If the POP image is from ANT-A, you can use PIP CH to change the POP image.

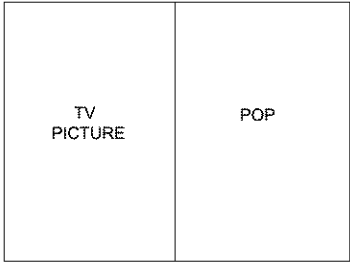

2. Press again to display three POP's. When the POP image is from ANT A, each image will be a different channel. Only one POP image will be live action. The others will be frozen.

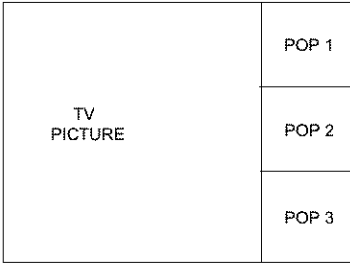

4. To return to a PIP image, press again.

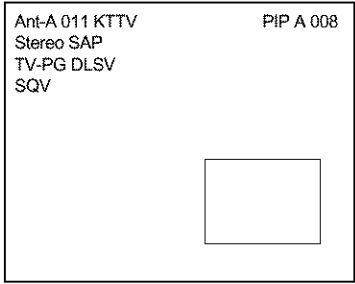

Remote Control of the Active AV Network

The AV Network is a special feature that makes it easier to use your television and other Mitsubishi A/V components together. When you connect the AV Network, you can point the remote control at the television, and it will pass the remote control command to other components. You will gain even more benefits if you have a Mitsubishi VCR equipped for the Active AV Network and a Mitsubishi DVD player.

Before you begin, be sure you have:

- Made the correct AV Network connections. Refer to “*Connection of TV to the Active AV Network*” in the Connections section.
- Connected your VCR to INPUT-1 of your TV and/or connected your DVD to DVD INPUT.
- Set your VCR’s remote control settings to VCR.
- Turned your VCR video mute setting on.
- Turned the Active AV Network feature in the VCR and the TV’s menu to ACTIVE.

Using the **PLAY** key on the remote, after selecting **VCR** with the slide switch:

- Active AV Network will turn your VCR on and begin playing a tape (if tape is inside).
- Active AV Network will turn your TV on and switch it to INPUT-1.
- When you turn your TV off, your VCR will turn off, **unless** it is playing or recording.

Displaying the VCR menu

When you set the remote to VCR and then press MENU:

- Active AV Network will turn on your VCR if it is off and display the VCR’s menu (this function may not work with some older Mitsubishi VCR’s).
- Active AV Network will turn on your TV if it is off and switch it to INPUT-1.

Using the **PLAY** key on the remote, after selecting **DVD** with the slide switch:

- Your remote must be programmed to operate Mitsubishi DVD players.
- Active AV Network will turn on your TV and switch it to DVD INPUT.
- If your DVD player is in range of the remote and has a disc inside, the DVD will turn on and the disc will begin playing.

IMPORTANT

When using the Active AV Network, always point your remote control at your television.

Control Panel Functions

Front Control Panels

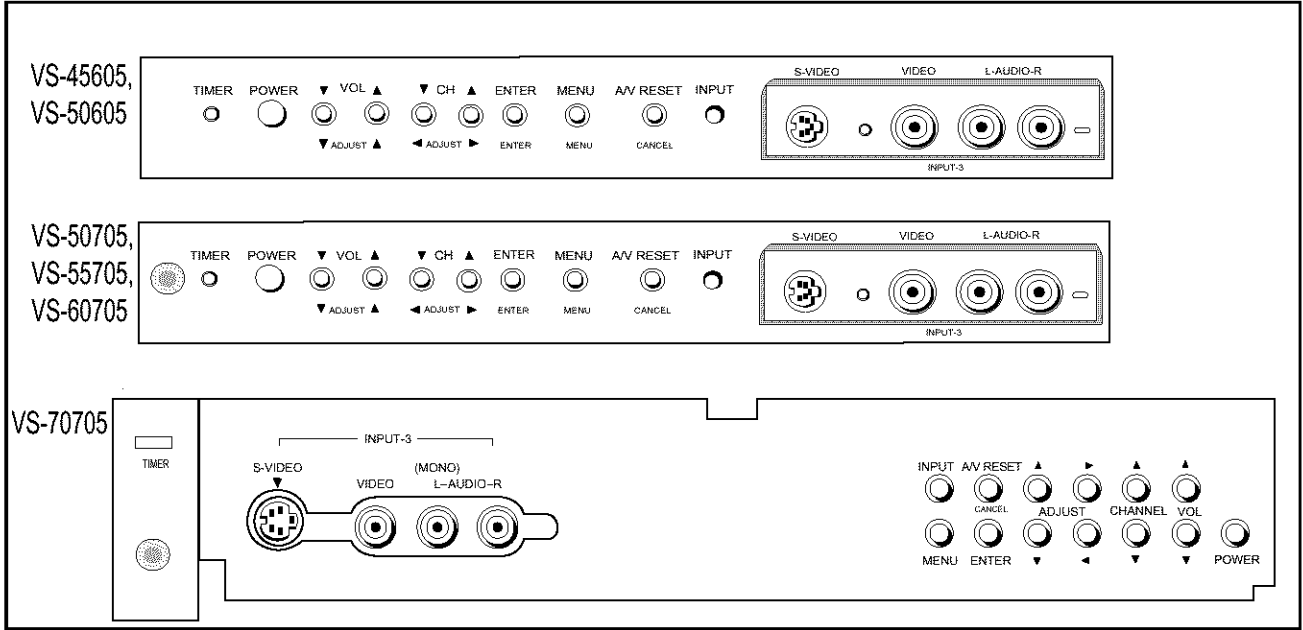

Back Panel Terminals

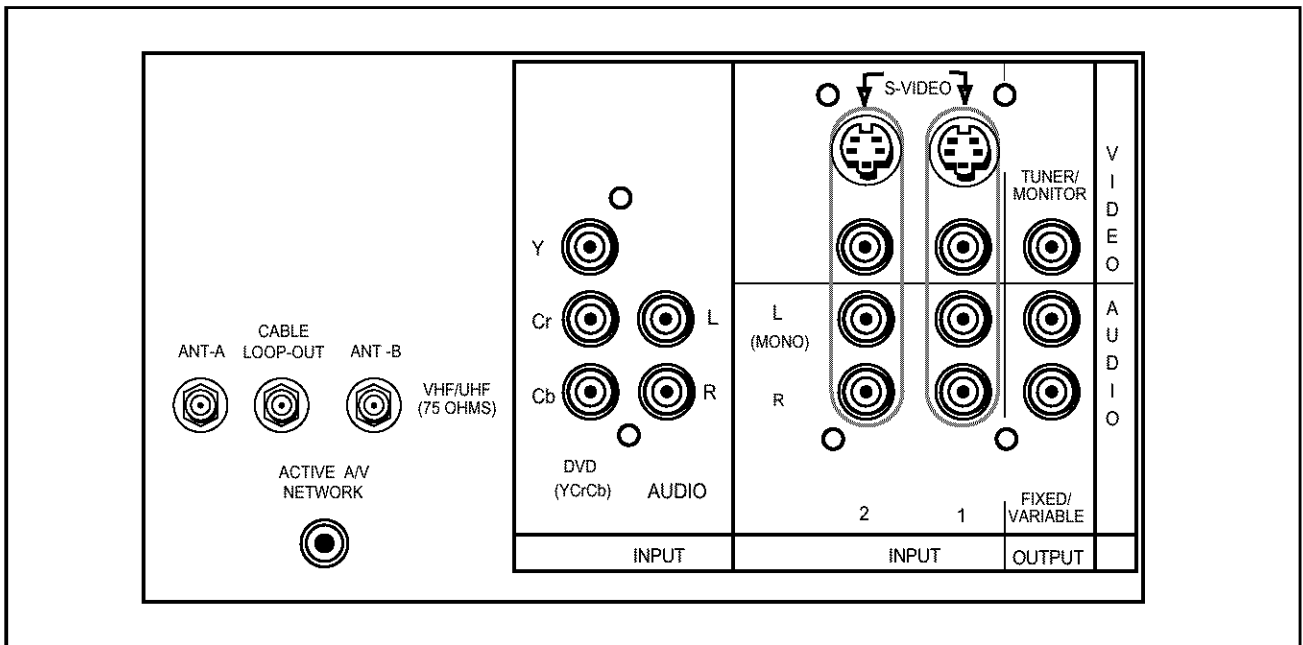

Front Panel Control Functions

Many remote control buttons are duplicated on the front control panel. Power, volume, channel and input operate the same way, using either remote control or front panel buttons.

IRIS™ (models VS-50705, VS-55705, VS-60705, VS-70705)



Intelligent Room Illumination (light) Sensor. Turn this feature on or off using the video button on your remote. When IRIS is on, your TV will automatically adjust picture contrast and brightness for the best picture based on your room lighting.

TIMER LIGHT

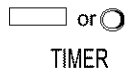

If you set the TV to turn on at a specific time (see Timer Menu in the Menu section) the light will blink green when the television is off. When the power is on, the light will shine steadily.

ADJUST, ▲▶▼ or ◀



These are the same as the buttons on your remote control. In the menu screens, you can use these buttons to move through the menu options and setting fields, make or delete selections.

A/V RESET



Press this button to reset all of the A/V memory categories to the factory default settings.

VIDEO



Connect the video output of a camcorder or other video component to the TV.

S-VIDEO



Connect the S-video output of a camcorder or other standard component to the TV. If you connect a S-video cable to this terminal, you cannot use the adjacent VIDEO input.

L-AUDIO-R



Connect the audio output from a camcorder or other component to your TV.

Back Panel Terminals

Antenna (ANT-A, CABLE LOOP-OUT, ANT-B)

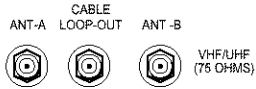

ANT A and ANT-B receive signals from VHF/UHF antennas or a cable system. CABLE LOOP OUT sends the ANT-A signal out to another component (such as a VCR).

Active A/V Network



Connects Mitsubishi product that have an A/V network terminal.

INPUT 1 and 2 S-Video

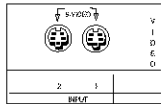

Either of these video terminals connect to a S-video signal from a Super VHS (S-VHS) VCR, laser disc player or other audio video device to the TV. If you connect to S-Video, you cannot connect to standard video.

INPUT 1 and 2 video input

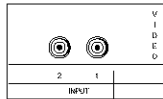

Connect the video output from a standard VCR or other equipment to the TV.

INPUT 1 and 2 audio input

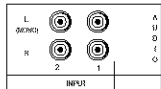

Connect the audio output from a VCR or other equipment to the TV.

Component video and audio input

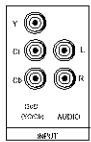

Connect the component video and audio signals from a DVD player or other equipment with component video outputs to the TV. If you connect the three component video terminals (DVD) and you wish to use the TV's built in speakers, use the adjacent audio inputs for your audio connection.

Video monitor/tuner output



Sends the TV video signal to an A/V receiver or other equipment.

Audio output

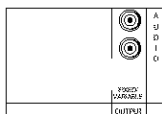

Sends the TV's audio signal to an A/V receiver or other equipment.

Troubleshooting

Problem	Possible Solution
<ul style="list-style-type: none"> The TV remote control doesn't work 	<ul style="list-style-type: none"> Check that the batteries are installed correctly. Check that the select switch is set to "TV". Be no more than 20 feet from the TV when using the remote control.
<ul style="list-style-type: none"> The TV takes several seconds to respond to channel commands 	<ul style="list-style-type: none"> Press ENTER after a command to avoid delays. Use the three digit number, i.e. 002 for channel 2.
<ul style="list-style-type: none"> You can't access a channel 	<ul style="list-style-type: none"> Be sure the channel you want to view is in memory. Check that the TV is tuned to the correct input source for that channel. Make sure the V-chip lock is off.
<ul style="list-style-type: none"> On-screen displays appear each time you change a function 	<ul style="list-style-type: none"> This is part of normal TV operation.
<ul style="list-style-type: none"> You can't program the TV to turn on automatically 	<ul style="list-style-type: none"> The TV may be locked. Clock is not set..
<ul style="list-style-type: none"> There's no sound even when the volume is turned up 	<ul style="list-style-type: none"> Check to see if the MUTE button is on. The TV's "Listen to:" setting may be set to S.A.P. Check that "TV Speakers" setting is ON.
<ul style="list-style-type: none"> You forget your parent lock passcode 	<ul style="list-style-type: none"> See "Bypassing the Parent Lock, Appendix 3".
<ul style="list-style-type: none"> Antenna-B doesn't appear as a PIP source 	<ul style="list-style-type: none"> Antenna B cannot be a PIP source when Antenna A is the main picture.
<ul style="list-style-type: none"> The sound doesn't match the screen picture 	<ul style="list-style-type: none"> The TV's "Listen to:" setting may be set to S.A.P. Change in Audio Video Memory Settings.
<ul style="list-style-type: none"> There is a large black or gray rectangle on the screen 	<ul style="list-style-type: none"> The TV has been set to "text" mode, but there is no text information being broadcast. Turn Off in the CAPTION menu (page 41).
<ul style="list-style-type: none"> You cannot see a picture when you play a VCR tape 	<ul style="list-style-type: none"> If you connected your VCR with A/V cables, use the INPUT button to select the Input source (Input 1,2, or 3) that the VCR is connected to.

Important Notes

Warning:

Don't leave stationary or letterboxed images on-screen for extended periods of time. Mix the types of pictures shown.

The normal use of a TV should include a mixture of television picture types. The most used pictures types should fill the screen with constantly moving images rather than stationary images or patterns. Displaying the same stationary patterns over extended periods of time, or displaying the same stationary pattern frequently can leave a subtle but permanent ghost image in your picture. Note that moving images with stationary black bars can also leave a subtle but permanent ghost image. To avoid this, mix your viewing pattern; do not show the same stationary image for more than 15% of your total TV viewing in any one week. Display constantly moving and changing images that fill the screen whenever possible.

This projection television uses picture tubes to project the image to the screen. All picture tubes age with use. As they age, their light output is gradually reduced. Normal television pictures fill the screen with constantly changing images. In these conditions, the picture tubes age at an even rate across the entire screen. This maintains a TV picture that is evenly bright over the whole screen. Stationary images or images that only partially fill the screen (leaving blank or colored bars to fill the screen), when used over extended periods of time or when viewed repeatedly, can cause uneven aging of the phosphors and leave subtle ghosts of the stationary images in the picture.

Uneven picture tube aging is not covered by the warranty.

Still or stationary images may be received from broadcasters, cable channels or satellite channels, DVD discs, video tapes, laser discs, on-line services or web/internet searching devices, video games and digital television tuner/converter boxes. Examples of these types of image can be, but are not limited to the following:

- **Letterbox top/bottom black bars**
(These are the black bars shown at the top and bottom of the screen when you watch a widescreen movie on a standard TV)
- **Side bar images**
(These are the solid bars shown on each side of the image when you watch a normal TV program on a widescreen TV)
- **Stock-market report bars**
(These are the row of stock prices normally shown at the bottom of the screen during a financial report)
- **Shopping channel logos and pricing displays**
(Especially bright displays that are shown constantly or repeatedly in the same place on the screen)
- **Video game patterns or scoreboards**
- **Bright station logos**
(Subtle, low-contrast logos are less likely to cause uneven aging, especially if they are translucent and are not always projected in the same spot)
- **On-line (internet) web sites**
or other computer style images that are not changed or are left on display for long periods of time

Important Notes, continued

Warning:

If you place speakers next to the TV, make sure they are magnetically shielded. Ordinary speakers will cause distortion in the picture due to their strong magnets. This distortion, however, will not harm the picture tubes.

For maximum enjoyment and safe operation of your Mitsubishi TV, please read *IMPORTANT SAFEGUARDS*, pages 3 and 4 of your Owners Guide, very carefully and apply them properly

Cleaning:

Normally, light dusting with a non-scratching duster will keep your TV clean.

If you want to wipe down your TV, turn it off and unplug it. Then, wipe it gently with a soft cloth slightly moistened with water. You can add a few drops of mild liquid detergent to the water for oily dirt.

DO NOT allow liquid to enter the TV through the ventilation slots.

DO NOT use strong or abrasive cleaners.

DO NOT use spray liquids or cleaners directly on the TV's surface.

DO NOT scrub or rub the TV harshly. Wipe gently.

If Service is Required

If you are unable to correct a problem with your TV, consult your Mitsubishi dealer or Mitsubishi Authorized Warranty Service Center.

DO NOT adjust any controls not described in this owner's guide.

DO NOT remove the protective back cover of this unit.

If you see the following display on your screen, you should not change any settings. This is a special display used by the factory.

If any settings are changed, your warranty may be void.

NOTE: "Series Settings" are included for reference only and will vary from those shown below.

If this display appears, make sure that all of the on/off settings are the same as the illustration below and then turn the TV off. If any of the settings are different from the illustration below, turn the TV off and consult your Mitsubishi dealer or Mitsubishi Authorized Warranty Service Center.

Initial	
E2RESET	
Power Res	: Off
When Mute	: On
Direct key mode	: Off
VS-70705	:
V-CHIP	: On
Series Setting:
Series Setting:	VZ7.....

For further assistance, please call 800-332-2119

Appendix I - Diamond Shield™

The custom-fitted Diamond Shield is an extra protection for your television screen. It has a subtle tint that enhances picture contrast. It can be removed or installed, according to your preference.

For VS-45605 and VS-50605, the Diamond Shield is an option that can be purchased separately from your Mitsubishi dealer.

For models that have the Diamond Shield already installed, you can remove the shield if you prefer.

For models where the Diamond Shield is included in a separate package, you can easily install the shield. Carefully remove the masking paper on the Diamond Shield. This is the coated, scratch-resistant side which should face outward from the TV. Then remove the plastic sheet from the other side of the Diamond Shield. This is the uncoated side which should face into the TV.

Wear cotton gloves to prevent fingerprints on the Diamond Shield.

Installation or removal of the Diamond Shield:

• For all models except VS-70705:

- remove the top molding clip with a small flat head screwdriver, pressed into the opening at the upper corner (Illustration 1)
- remove the bottom molding clip, with a small flat head screwdriver, pressed into opening at the bottom corner
- after loosening corners, pull gently to remove
- to **install**, insert shield by sliding it into the right side channel (Illustration 3)
- gently press on the shield sides to bow the screen towards you
- insert the left side channel
- reinstall the molding clips. Do not force.
- to **remove**, remove the top and bottom molding clips and gently press on the shield sides to bow the screen towards you. It will pop out of the top panel (Illustration 3)
- reinstall the molding clips. Do not force.

VS-45605, VS-50605, VS-50705, VS-55705, VS-60705

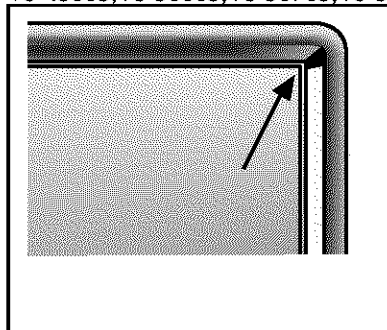

Illustration 1

IMPORTANT
Store your Diamond Shield™
carefully so that the shield does not
become scratched.

VS-70705

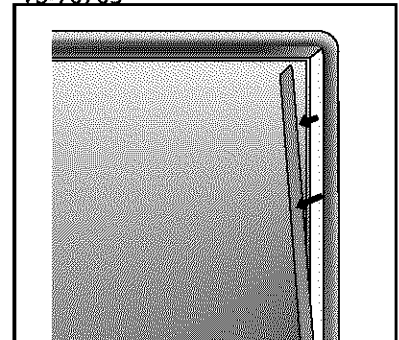

Illustration 2

Appendix I- Diamond Shield™, continued

- For **VS-70705**:

- remove the right side molding clip with a small flat head screwdriver, pressed into the opening between molding and TV side panel (Illustration 2)
- remove the left side molding clip, with a small flat head screwdriver, pressed into opening between molding and TV side panel
- after loosening corners, pull gently to remove
- to **install**, insert shield by sliding it into the bottom channel (Illustration 4)
- gently press on the shield top to bow the screen towards you
- insert into top channel
- reinstall the molding clips. Do not force.
- to **remove**, gently press on the shield top to bow the screen towards you. It will pop out of the side panel. (Illustration 4)

VS-45605, VS-50605, VS-50705, VS-55705, VS-60705

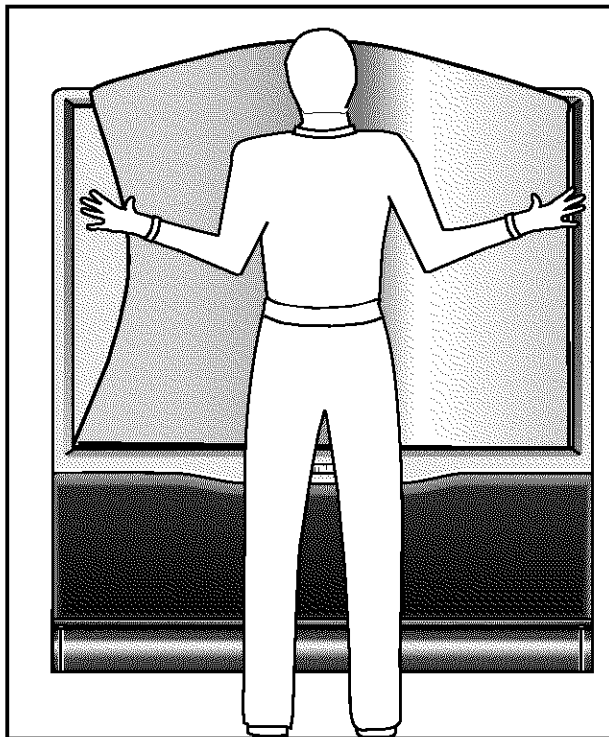

Illustration 3

VS-70705

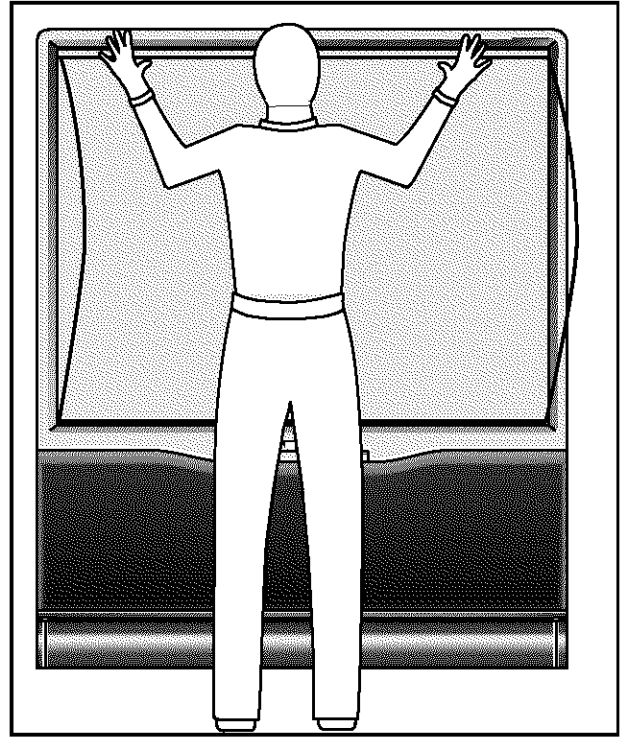

Illustration 4

Appendix 2 - Remote Control Programming Codes

AV Receiver

Mitsubishi	011, 012, 013, 014, 010
Admiral	220
Aiwa	225, 226
Denon	234, 235, 236
Fisher	204
Gerrard	213
Harman Kardon	215
Jensen	223
JVC	232, 233
Kenwood	200, 208
Magnavox	227, 228
Marantz	224
Mclintosh	216
Nakamichi	206, 217
Onkyo	209, 214
Optimus	203, 227, 231, 230
Panasonic	219, 218, 221
Philips	223
Pioneer	205, 207
Quasar	219, 218, 221
RCA	203, 205, 227, 231, 230
Sansui	203, 211, 239
Sharp	234, 237
Sony	222
Sound-sigh	238
TEAK	212, 213, 210, 211
Technics	221, 218, 219
Victor	232, 233
Yamaha	201, 202

DVD

Mitsubishi	003
Denon	250
Ferguson	251
GE	251
JVC	257
Normande	251
Panasonic	250
Philips/Magnavox	258
Pioneer	252
RCA/Proscan	251, 256
Saba	251
Sony	254
Thomson	251
Toshiba	253
Yamaha	250
Zenith	259

Satellite Receiver

Echostar	175
G.E.	176
Hitachi	173, 181
Hughes	173
Panasonic	174
Philips	171, 172
Primestar	178
RCA	176, 179, 180
Sony	177
Toshiba	170
Uniden	171, 172

Cable

ABC	124
Archer	132, 125
Cableview	105, 132
Citizen	122, 105
Color Voice	128, 129, 130, 106, 107
Comtronics	128, 129, 130, 106, 107
Curtis	112, 113
Diamond	124, 132, 125
Eagle	129
Eastern	134
GC Brand	132, 105
GE	111, 112, 113
Gemini	122, 143
General Instrument/Jerrold	111, 119, 124, 125, 126, 127, 120, 121, 122, 123
Hamlin	140, 141, 142, 145, 118, 112
Hitachi	103, 124
Macom	103, 104, 105, 108
Magnavox	128, 129, 130, 106, 107, 133, 138
Memorex	130
Movietime	132
Oak	139, 137, 102
Panasonic	109, 110, 114
Paragon	117
Philips	128, 129, 130, 106, 107, 133, 138
Pioneer	101, 116
Pulsar	105, 132
Puser	132
RCA	115
Realistic	132
Regal	112, 118, 140, 141, 142, 145
Regency	134
Rembrandt	137, 132, 105, 138
Samsung	105
Satellite	100
Scientific Atlanta	111, 112, 113
Signature	119, 124, 125, 126, 127, 120, 121, 122, 111
SL Mark	105, 101
Sprucer	105, 110
Starcom	119, 124, 125, 126, 127, 120, 121, 122, 111
Stargate	132, 105
Televue	101, 105
Texscan	144
Tocom	135, 136
Toshiba	104
Unika	132, 125
United Artists	139, 137, 102
United Cable	119, 124, 125, 126, 127, 120, 121, 122, 111
Universal	122, 132
Videoway	106
Viewstar	129, 130
Zenith	117, 100

Appendix 2 - Remote Control Programming Codes continued

VCR

Mitsubishi	001, 060, 067, 068, 061, 062, 002
Admiral	055
Aiwa	047, 052
Akai	049, 034, 035, 036
Audio Dynamic	059, 031
Bell & Howell	025, 033
Broksonic	040, 046
Canon	043, 045
Citizen	026
Craig	025, 049, 026
Curtis Mathes	065, 044, 047
Daewoo	063, 021, 044, 079
DBX	059, 030, 031
Dimensia	065
Emerson	023, 038, 039, 040, 045, 046, 062, 063,
Fisher	025, 028, 029, 027
Funai	047, 046, 040
GE	057, 065, 044
Go Video	057, 069, 070, 071
Goldstar	026
Hitachi	043, 065, 020
Instant Replay	044, 043
Jensen	059
JVC	059, 030, 031, 054, 076, 077
Kenwood	059, 030, 026, 031
LXI	047, 026, 020, 027, 028, 025, 029
Magnavox	051, 043, 044
Marantz	059, 030, 031
Marta	026
Memorex	044, 029
MGA	058, 060, 067, 068, 061, 062
Minolta	020, 065
Multitech	067, 047, 024
NEC	059, 030, 031, 054
Olympic	044, 043
Optimus	048, 041, 055, 026
Orion	046, 040
Panasonic	043, 044, 041, 042
Penney	044, 020, 065, 025, 059, 030, 031
Pentax	020, 031, 065
Philco	051, 044, 047, 043, 046, 040
Philips	051, 043, 044
Pioneer	043
Proscan	065, 020, 043, 044, 051, 066, 021, 022
Quasar	041, 042, 043, 044
Radio Shack	053, 044, 025, 056, 029, 060, 047
RCA	053, 065, 020, 043, 044, 049, 051, 066, 021, 022
Realistic	044, 025, 056, 029, 060, 047
Samsung	057, 022, 024, 053
Sansui	059, 046, 040, 072
Sanyo	025, 029
Scott	021, 022, 024, 029, 058, 060, 067, 068, 046, 040
Sears	025, 026, 027, 028, 020
Shaintom	037
Sharp	055, 056
Signature 2000	047, 055
Singer	037
Sony	048, 049, 050, 073, 074, 075
SV2000	047
Sylvania	051, 043, 044, 047
Symphonic	047
Tashiro	026
Tatung	059, 030, 031
TEAC	059, 030, 047, 031
Technics	032, 041, 042, 043, 044
Teknika	044, 047
Toshiba	021, 066
Totevision	026
Vector Research	031
Wards	055, 056, 029, 064, 026
Yamaha	025, 059, 030, 031
Zenith	064

Appendix 3 - Bypassing the Parent Lock











Cut along dotted line and file after reading.

After you set the lock, you will need the secret code in order to:

- view a locked program,
- view the locked TV, or
- cancel the lock.

If you forget the code, you can view the locked TV without entering the code. To do this, simply press the buttons on your remote labeled “QV” and “9” at the same time whenever your secret code is requested. Unlocking the TV this way is temporary.

To change or permanently cancel the lock:

1. Turn on your TV. If the TV requests your secret code, press  and  at the same time.
2. Press  to view the main menu.
3. Use the  or  to select “V-Chip Parent Lock” and press .
4. The on-screen display will ask for your current passcode. Press  and  at the same time.
5. The on-screen display will now ask you to enter a new code:
 - To cancel the passcode permanently, press  or .
 - To change to a new passcode, use the number buttons to enter a new code, then press .

IMPORTANT

You must use the remote control included with this TV. You cannot use a remote control from another Mitsubishi component and you cannot use “Universal” remotes from other manufacturers.

This page is blank

Index

A

- Active AV Network 28, 53
- Adding and deleting channels 37
- Adjustments
 - picture 47
 - sound 47-48
- Advanced features menu 23, 40-44
- Audio output 29
- Audio/video memory settings 45, 46
- Audio/video settings menu 24, 45-46
- AV connection menu 27-29
- AV receiver
 - at Input 1 28
 - codes 18, 63

B

- Back panel terminals, 56
- Buttons, remote control 19-20

C

- Cable Box codes 17, 63
- Channel edit menu 23, 37-39
- Cleaning 59
- Clock, setting 26
- Closed captioning 41
- Connections to
 - Active A/V Network 12
 - antenna 9
 - AV receiver 13
 - cable box 9
 - component DVD 14
 - Stereo Audio System 12
 - VCR and cable box 10
 - VCR and Antenna or Cable 11
 - wall outlet cable 9
- Convergence
 - Advanced 44
 - Resetting factory defaults 44
 - Static 43

D

- Day, setting 26
- Diamond Shield™ Installation 61-62
- DVD player codes 18, 63

F

- Front panel buttons 55

H

- Home theater connections chart 30
- Hookup, Choosing a 7

I

- Important Safeguards 5-6

L

- Language, menu 29

M

- Main menu 22
- Memorizing channels menu 25
- Menu
 - Advanced Features 23, 40-44
 - Audio output 29
 - Audio/Video Settings 24
 - AV network 28
 - AV connection 27-30
 - AV receiver at Input 1 28
 - Channel edit 23, 37-39
 - Closed captioning 41
 - Language 29
 - Main 22
 - Memorizing Channels 25
 - Parent Lock 23, 33-36
 - Set Clock 25
 - Set Day 26
 - Setup 22, 25-27
 - TV speakers 28
 - Viewpoint Menu System 21

N

Name
channels 38
inputs 38

P

Parent Lock
bypassing 65
menu 23, 33-36
passcode setting 33
setting 33
time lock 36
V-chip ratings and categories 34-35

Picture, adjusting 45

PIP (Picture-in-Picture) 50
changing channel 51
changing the size 51
exchanging with main picture 52
freezing 51
Input source 50, 51
moving 51

POP (Picture-outside-Picture) 52

R

Remote Control 16
AV receiver codes 18, 63
buttons 19-20
cable box codes 17, 63
Complete list of codes 63-64
controlling other Audio
Video Product 17-18
DVD player codes 18, 63
installing batteries 16
menu operation 21
satellite receiver code 17, 63
special functions 49
VCR codes 17, 64
Remote Control Functions, special 49
Remote control operation 16

S

Satellite receiver codes 17, 63
Service, required 60
Setup menu 22, 25-27
Shortcuts 8
Sleep Timer 32
Special Features 7

Sound, adjusting 47-48
SQV (SuperQuickView™) 19, 39

T

Timer
automatic television turn on 42
sleep 32
Troubleshooting 57
TV speakers 28

U

Unpacking Your TV 7

V

Viewpoint Menu System 21
VCR codes 17, 64
Video mute 42

**MITSUBISHI
PROJECTION TELEVISION
LIMITED WARRANTY**

MITSUBISHI DIGITAL ELECTRONICS AMERICA, INC. ("MDEA") warrants to the original purchaser of this television that if purchased from an authorized MITSUBISHI Audio/Video Dealer, should it prove defective by reason of improper workmanship and/or material:

a. **Parts.** The lenticular (i.e. front picture) screen and/or the DiamondShield™ is warranted against defects in materials and workmanship for a period of 30 days. All other parts are warranted for a period of one year from the date of the original purchase at retail. We will repair or replace, at our option, any defective part without charge for the part. Parts used for replacement are warranted for the remainder of the original warranty period.

b. **Labor.** For 30 days after the original purchase at retail, we will repair or replace, at our option, the lenticular screen if it proves defective. For all other parts, we will provide the labor for a warranty repair by an authorized MITSUBISHI service center without charge for one year from the date of original purchase at retail.

c. **Notice.** To obtain warranty service, you must notify an authorized MITSUBISHI service center of any defect within the applicable warranty time period.

I. TO OBTAIN WARRANTY SERVICE:

a. Contact your nearest authorized MITSUBISHI service center whose name and address can be obtained from your MITSUBISHI dealer or by writing or calling MDEA at the address and telephone number provided below.

b. Warranty service will be provided in your home or, if required, at an authorized service shop, provided that your television is located within the geographic territory customarily covered by an authorized MITSUBISHI service center. If not, you must either deliver your television to an authorized service location at your own expense, or pay for any travel and/or transportation costs the service center may charge to and from your home. Actual service labor will be provided without charge.

c. Proof of purchase date from an authorized MITSUBISHI dealer is required when requesting warranty service. Present your sales receipt or other document which establishes proof and date of purchase. **THE RETURN OF THE OWNER REGISTRATION CARD IS NOT A CONDITION OF WARRANTY COVERAGE.** However, please return the Owner Registration Card so that we can contact you should a question of safety arise which could affect you.

2. **THIS WARRANTY DOES NOT COVER** damage caused by: modification, alteration, repair or service of the product by anyone other than an authorized MITSUBISHI service center; physical abuse to, or misuse of, the product; operation in a manner contrary to the instructions which accompany the product, including uneven picture tube aging and imprinted images on the viewing screen; freight damage; or any damage caused by acts of God such as lightning or fluctuation in electrical power. This warranty also excludes all costs arising from installation, adjustment of user controls, external antenna systems, service of products purchased or serviced outside the U.S.A., initial technical adjustments (set-up) and user-required maintenance. Consult the operating instructions furnished with the product for information regarding user controls.

3. **ANY EXPRESS WARRANTY NOT PROVIDED HEREIN, AND ANY REMEDY WHICH, BUT FOR THIS PROVISION, MIGHT ARISE BY IMPLICATION OR OPERATION OF LAW, IS HEREBY EXCLUDED AND DISCLAIMED. THE IMPLIED WARRANTIES OF MERCHANTABILITY AND OF FITNESS FOR ANY PARTICULAR PURPOSE ARE EXPRESSLY LIMITED TO A TERM OF ONE YEAR.**

4. **UNDER NO CIRCUMSTANCES SHALL MDEA BE LIABLE TO PURCHASER OR ANY OTHER PERSON FOR ANY INCIDENTAL, SPECIAL OR CONSEQUENTIAL DAMAGES, WHETHER ARISING OUT OF BREACH OF WARRANTY, BREACH OF CONTRACT, OR OTHERWISE.**

5. Some states do not allow limitations on how long an implied warranty lasts, or the exclusion or limitation of incidental, special, or consequential damages, so the above limitations or exclusions may not apply to you.

6. This warranty gives you specific legal rights, and you may also have other rights which vary from state to state.

7. **BEFORE REQUESTING SERVICE,** please review the instruction booklet to insure proper installation and correct customer control adjustment. If the problem persists, contact your nearest MITSUBISHI Dealer for name(s) of authorized MITSUBISHI Service Center(s). If you are unable to obtain this information, please call 800-332-2119, or write us at the address below.

MITSUBISHI DIGITAL ELECTRONICS AMERICA, INC.
9351 Jeronimo Road
Irvine, CA 92618-1904



RETAIN THIS PORTION FOR YOUR RECORDS

SERIAL NO. _____

MODEL NO. _____

DEALER NAME _____

STREET ADDRESS _____

CITY _____ STATE _____ ZIP _____

PHONE () _____ PURCHASE DATE _____ / _____ / _____

MO DAY YR



MITSUBISHI DIGITAL ELECTRONICS AMERICA, INC.

935 I Jeronimo Road
Irvine, CA 92618-1904