

Digital Palmcorder®
Camcorder

Panasonic®

Digital Video Camcorder
Operating Instructions

Model No. **PV-DV52**

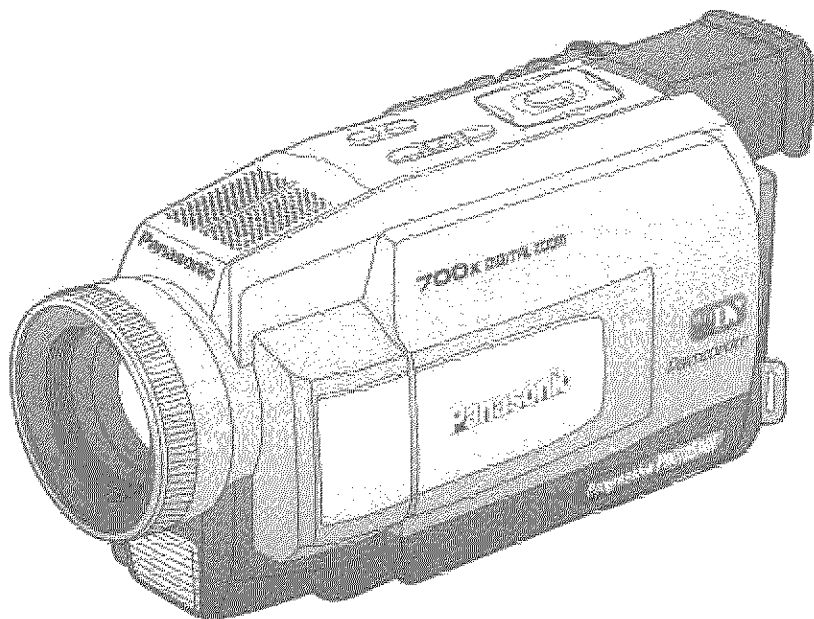

Mini **DV**

Before attempting to connect, operate or adjust this product, please read these instructions thoroughly.

Spanish Quick Use Guide is included.

Guía para rápida consulta en español está incluida.

For assistance, please call: 1-800-211-PANA(7262) or e-mail to: consumerproducts@panasonic.com

LSGT0002A

Thank you for choosing Panasonic!

You have purchased one of the most sophisticated and reliable products on the market today. Used properly, we're sure it will bring you and your family years of enjoyment. Please take time to fill in the information below. The serial number is on the tag located on the underside of your Palmcorder. Be sure to **retain this manual** as your convenient Palmcorder information source.

Date of Purchase _____

Dealer Purchased From _____

Dealer Address _____

Dealer Phone No. _____

Model No. _____





Serial No. _____

Safety Precautions

WARNING: TO PREVENT FIRE OR SHOCK HAZARD, DO NOT EXPOSE THIS EQUIPMENT TO RAIN OR MOISTURE.

Your ^{Mini} DV Palmcorder is designed to record and play back in Standard Play (SP) mode and Long (LP) mode.

It is recommended that only cassette tapes that have been tested and inspected for use in VCR machines with the ^{Mini} DV mark be used.

	CAUTION RISK OF ELECTRIC SHOCK DO NOT OPEN	
CAUTION: TO REDUCE THE RISK OF ELECTRIC SHOCK, DO NOT REMOVE COVER (OR BACK) NO USER-SERVICEABLE PARTS INSIDE REFER SERVICING TO QUALIFIED SERVICE PERSONNEL		
	This symbol warns the user that uninsulated voltage within the unit may have sufficient magnitude to cause electric shock. Therefore, it is dangerous to make any kind of contact with any inside part of this unit.	
	This symbol alerts the user that important literature concerning the operation and maintenance of this unit has been included. Therefore, it should be read carefully in order to avoid any problems.	

The above markings are located on the appliance bottom cover.

Declaration of Conformity

Model Number : **PV-DV52**
Trade Name : **Panasonic**
Responsibility Party : **Matsushita Electric Corporation of America**
Address : **One Panasonic Way Secaucus New Jersey 07094**
Telephone Number : **1-800-211-PANA(7262)**

This device complies with Part 15 of the FCC Rules. Operation is subject to the following two conditions: (1) This device may not cause harmful interference, and (2) this device must accept any interference received, including interference that may cause undesired operation.

Note: This equipment has been tested and found to comply with Part 15 of the FCC Rules. These limits are designed to provide reasonable protection against harmful interference when operated in a residential environment.

If this equipment does cause interference to radio or television reception, which can be determined by turning the equipment off and on, use the equipment in another location and/or utilize an electrical outlet different from that used by the receiver.

If necessary, consult the dealer or an experienced radio/TV technician for help. You may find the booklet, 'Something About Interference' available from FCC local regional offices helpful.

FCC Warning: To assure continued FCC compliance, use only the specified shielded interface cable when connecting digital video camcorder to computer in accordance with instruction herein. Also, any unauthorized changes or modifications to this equipment would void the user's authority to operate.

1. **Read Instructions** — All the safety and operating instructions should be read before the unit is operated.
2. **Retain Instructions** — The safety and operating instructions should be retained for future reference.
3. **Heed Warnings** — All warnings on the unit and in the operating instructions should be adhered to.
4. **Follow Instructions** — All operating and maintenance instructions should be followed.
5. **Cleaning** — Unplug this video unit from the wall outlet before cleaning. Do not use liquid or aerosol cleaners. Use a dry cloth for cleaning.
6. **Attachments** — Do not use attachments not recommended by the video product manufacturer as they may be hazardous.
7. **Water and Moisture** — Do not use this video unit near water — for example near a bath tub, wash bowl, kitchen sink, or laundry tub, in a wet basement, or near a swimming pool, and the like.
8. **Accessories** — Do not place this video unit on an unstable cart, stand, tripod, bracket, or table. The video unit may fall, causing serious injury to a child or adult, and serious damage to the unit. Use only with a cart, stand, tripod, bracket, or table recommended by the manufacturer, or sold with the video unit. Any mounting of the unit should follow the manufacturer's instructions and should use a mounting accessory recommended by the manufacturer. An appliance and cart combination should be moved with care. Quick stops, excessive force, and uneven surfaces may cause the appliance and cart combination to overturn.



9. **Ventilation** — Slots and openings in the cabinet are provided for ventilation and to ensure reliable operation of the video unit and to protect it from overheating. These openings must not be blocked or covered. Never place the video unit on a bed, sofa, rug, or other similar surface, or near or over a radiator or heat register. This video unit should not be placed in a built-in installation such as a bookcase or rack unless proper ventilation is provided or the manufacturer's instructions have been adhered to.
10. **Power Sources** — This video unit should be operated only from the type of power source indicated on the marking label. If you are not sure of the type of power supply to your home, consult your appliance dealer or local power company. For video units intended to be operated from battery power, or other sources, refer to the operating instructions.

11. **Grounding or Polarization** — This video unit may be equipped with either a polarized 2-wire AC (Alternating Current) line plug (a plug having one blade wider than the other) or 3-wire grounding type plug, a plug having a third (grounding) pin.

The 2-wire polarized plug will fit into the power outlet only one way. This is a safety feature. If you are unable to insert the plug fully into the outlet, try reversing the plug. If the plug still fails to fit, contact your electrician to replace your obsolete outlet. Do not defeat the safety purpose of the polarized plug.

The 3-wire grounding type plug will fit into a grounding type power outlet. This is a safety feature. If you are unable to insert the plug into the outlet, contact your electrician to replace your obsolete outlet. Do not defeat the safety purpose of the grounding type plug.

12. **Power-Cord Protection** — Power-supply cords should be routed so that they are not likely to be walked on or pinched by items placed upon or against them, paying particular attention to cords of plugs, convenience receptacles, and the point where they exit from the unit.
13. **Outdoor Antenna Grounding** — If an outside antenna or cable system is connected to the video unit, be sure the antenna or cable system is grounded so as to provide some protection against voltage surges and built-up static charges. Part 1 of the Canadian Electrical Code, in USA Section 810 of the National Electrical Code, provides information with respect to proper grounding of the mast and supporting structure, grounding of the lead-in wire to an antenna discharge unit, size of grounding conductors, location of antenna discharge unit, connection to grounding electrodes, and requirements for the grounding electrode.

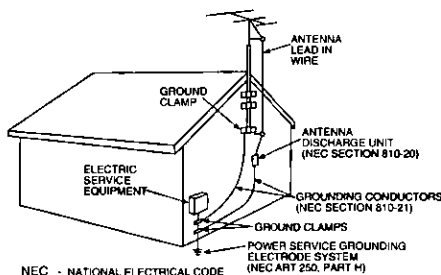

14. **Lightning** — For added protection of this video unit receiver during a lightning storm, or when it is left unattended and unused for long periods of time, unplug it from the wall outlet and disconnect the antenna or cable system. This will prevent damage to the video unit due to lightning and power-line surges.

Important Safeguards

15. **Power Lines** — An outside antenna system should not be located in the vicinity of overhead power lines or other electric light or power circuits, or where it can fall into such power lines or circuits. When installing an outside antenna system, extreme care should be taken to keep from touching such power lines or circuits as contact with them might be fatal.
16. **Overloading** — Do not overload wall outlets and extension cords as this can result in a risk of fire or electric shock.
17. **Objects and Liquids** — Never push objects of any kind into this video unit through openings as they may touch dangerous voltage points or short out parts that could result in a fire or electric shock. Never spill liquid of any kind onto the video unit.
18. **Servicing** — Do not attempt to service this video unit yourself as opening or removing covers may expose you to dangerous voltage or other hazards. Refer all servicing to qualified service personnel.
19. **Damage Requiring Service** — Unplug this video unit from the wall outlet and refer servicing to qualified service personnel under the following conditions:
 - a. When the power-supply cord or plug is damaged.
 - b. If any liquid has been spilled into, or objects have fallen onto, the video unit.
 - c. If the video unit has been exposed to rain or water.
 - d. If the video unit does not operate normally by following the operating instructions. Adjust only those controls that are covered by the operating instructions, as an improper adjustment of other controls may result in damage and will often require extensive work by a qualified technician to restore the video unit to its normal operation.
 - e. If the video unit has been dropped or the cabinet has been damaged.
 - f. When the video unit exhibits a distinct change in performance — this indicates a need for service.
20. **Replacement Parts** — When replacement parts are required, be sure the service technician has used replacement parts specified by the manufacturer or have the same characteristics as the original part. Unauthorized substitutions may result in fire, electric shock or other hazards.
21. **Safety Check** — Upon completion of any service or repairs to this video unit, ask the service technician to perform safety checks to determine that the video unit is in safe operating order.

Precautions

USE & LOCATION

- **TO AVOID SHOCK HAZARD ...** Your Palmcorder and power supply should not be exposed to rain or moisture. Do not connect the power supply or operate your Palmcorder if it gets wet. Your Palmcorder has been designed for outdoor use, however it is not designed to sustain direct exposure to water, rain, sleet, snow, sand, dust, or direct splashing from a pool or even a cup of coffee. This action could permanently damage the internal parts of your Palmcorder. Do not attempt to disassemble this unit. There are no user serviceable parts inside. Unplug your Palmcorder from the power supply before cleaning.
- **DO NOT AIM YOUR PALMCORDER AT THE SUN OR OTHER BRIGHT OBJECTS**
- **DO NOT LEAVE THE PALMCORDER WITH THE EVF AIMED DIRECTLY AT THE SUN AS THIS MAY CAUSE DAMAGE TO THE INTERNAL PARTS OF THE EVF**
- **DO NOT EXPOSE YOUR PALMCORDER TO EXTENDED HIGH TEMPERATURE ...** Such as, direct sunlight, inside a closed car, next to a heater, etc... This action could permanently damage the internal parts of your Palmcorder.
- **AVOID SUDDEN CHANGES IN TEMPERATURE ...** If the unit is suddenly moved from a cold place to a warm place, moisture may form on the tape and inside the unit.
- **DO NOT LEAVE YOUR PALMCORDER OR THE POWER SUPPLY TURNED ON WHEN NOT IN USE.**
- **STORAGE OF YOUR PALMCORDER ...** Store and handle your Palmcorder in a manner that will not subject it to unnecessary movement (avoid shaking and striking). Your Palmcorder contains a sensitive pick-up device which could be damaged by improper handling or storage.

CARE

- **TO CLEAN YOUR PALMCORDER ...** Do not use strong or abrasive detergents when cleaning your Palmcorder body.
- **TO PROTECT THE LENS ...** Do not touch the surface of the lens with your hand. Use a commercial Palmcorder lens solution and lens paper when cleaning the lens. Improper cleaning can scratch the lens coating.
- **TO PROTECT THE FINISH OF YOUR PALMCORDER ...** Before handling your Palmcorder, make sure your hands and face are free from any chemical products, such as suntan lotion, as it may damage the finish.

Things You Should Know	2
Important Safeguards	3
Precautions	4
Before Using	6
• Easy Cassette Eject	7
Quick Guide	9
Supplying Power	11
Setting the Clock	13
Using the Palmcorder Menu	14

Before Use

Camera Recording	15
• Simple Recording	15
• Digital PhotoShot™ Mode	17
• Zoom	18
Special Effect Features	20
Advanced Settings	24

Camera

Playback Your Recordings	28
Special Effect Features	30

VCR

Digital Features	34
Editing Features	38
PC Connection	42
PHOTOVU LINK (Optional)	44

Special Features

Palmcorder Accessory System	46
Palmcorder Accessory Order Form	47
Notes On Operations	48
Specifications	50
Before Requesting Service	51
Request for Service Notice	52
On-Screen Display (OSD)	53
Limited Warranty	54
Servicenter List	55
Spanish Quick Use Guide/Guía Para Uso Rápido	56
MENU OSD	59
Electronic Viewfinder/LCD Monitor Indications	63
Index of Controls	65
Index	Back Cover

For Your Information

Unpack your Palmcorder

1 pc. AC Adaptor (PV-DAC11) with AC Cable and DC Cable



1 pc. Battery Pack (CGR-D08/CGR-D08R)



1 pc. A/V Cable (LSJA0280)



1 pc. Lens Cap (LSYF0518) with Lens Cap Strap (LSGQ0066)



1 pc. Shoulder Strap (LSFC0012)



Microsoft® and Windows® are registered trademarks of Microsoft in the United States and other countries.

Intel® Pentium® is a registered trademark.

i.LINK is a trademark.

PHOTOVU LINK is a registered trademark.

IBM is a registered trademark of IBM Company.

Record Speed/Playback Time

Use only those tapes having the ^{mm} DV logo indicating the 6.35 mm digital standard.

Cassette type	Record Speed/ Playback time	
	SP	LP
AY-DVM30EA	30 minutes	45 minutes
AY-DVM60EA	60 minutes	90 minutes
AY-DVM80EA	80 minutes	120 minutes

Erase Protection

Cassettes have a sliding record tab to ensure recordings are not accidentally erased.

- To prevent accidental erasure:**
Slide the tab to the left (open).



- To record again:**
Slide the tab to the right (close).



Easy Cassette Eject/Insertion

- If the Palmcorder is connected to a power source, the cassette can be inserted and ejected without turning the Palmcorder on.

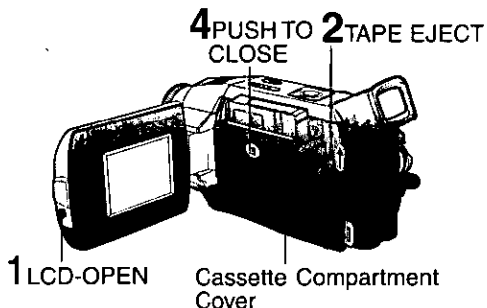

Before you begin

- Connect the Palmcorder to a power source. (pp. 11, 12)

- 1 Press **LCD-OPEN** to unlock the LCD monitor, and **swing it fully open**.
- 2 Slide **TAPE EJECT** to open the Casette Compartment Cover.
- 3 Insert a cassette record tab up, window side facing out.
- 4 Press **PUSH TO CLOSE** to close the Casette Compartment Cover.

- **To remove the cassette...**
Slide **TAPE EJECT** to open the Casette Compartment Cover and pull the cassette tape straight out.

Note

- When inserting the cassette, make sure it is facing the right direction and then push it in completely.

Attaching the Shoulder Strap

- 1 Undo the two strap ends from their buckles.



- 2 Thread the strap ends through the Strap Attachment Rings.

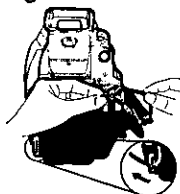

- 3 Reinsert the strap ends through their buckles.
 - Make sure the straps are not twisted.

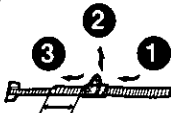

Adjust the Length

- 1 Loosen the strap from the Buckle and create a loop.
- 2 Pull the strap firmly through the Buckle to shorten or lengthen the strap.

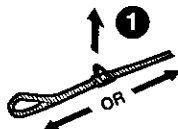

Hand Strap

Adjust the length of the Hand Strap to the size of your hand as illustrated.

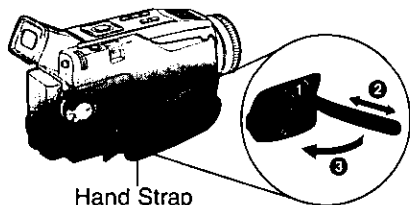

Hand Strap

Lens Cap

Attaching the Lens Cap Strap:

Thread the Lens Cap Strap through the Strap Attachment Ring as shown.



Attaching the Lens Cap Cord to the Hand Strap:

Remove the Hand Strap from the front clasp and thread the Strap through the loop in the Lens Cap Cord.

Reattach the Hand Strap.

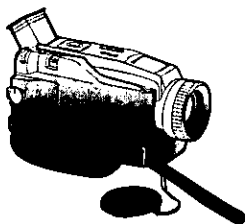

Using the Built-in Light

To brighten the natural colors in a scene.

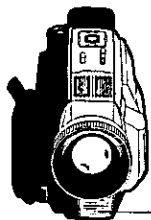

Built-in Light

Before you begin

- Connect the Palmcorder to a power source. (pp. 11, 12)
- Set POWER to CAMERA.

- 1 Hold down LIGHT for more than 0.7 seconds to turn ON or OFF.
 - "ID" will appear on the screen.

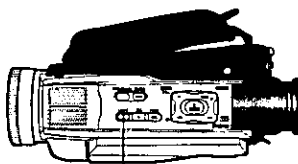

1 LIGHT

Caution

This light becomes hot during operation. Make sure nothing covers the light during operation.

Note

- Using Light reduces battery time.
- Provide adequate ventilation if using Light in a hot environment for a long time.
- Set LIGHT to OFF when not in use.
- When replacing the bulb, see page 48.

Insert the Battery Pack

Before you begin

- Charge the Battery. (p. 11)

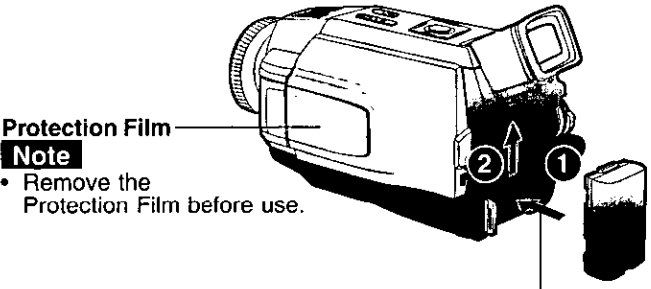

Protection Film

Note

- Remove the Protection Film before use.

1 Insert the Battery Pack and slide it up until it locks with a click.

Insert Cassette

These Palmcorders are equipped with the Easy Cassette Eject System so it is easy to insert or remove tapes, even when on a tripod. (p. 7)

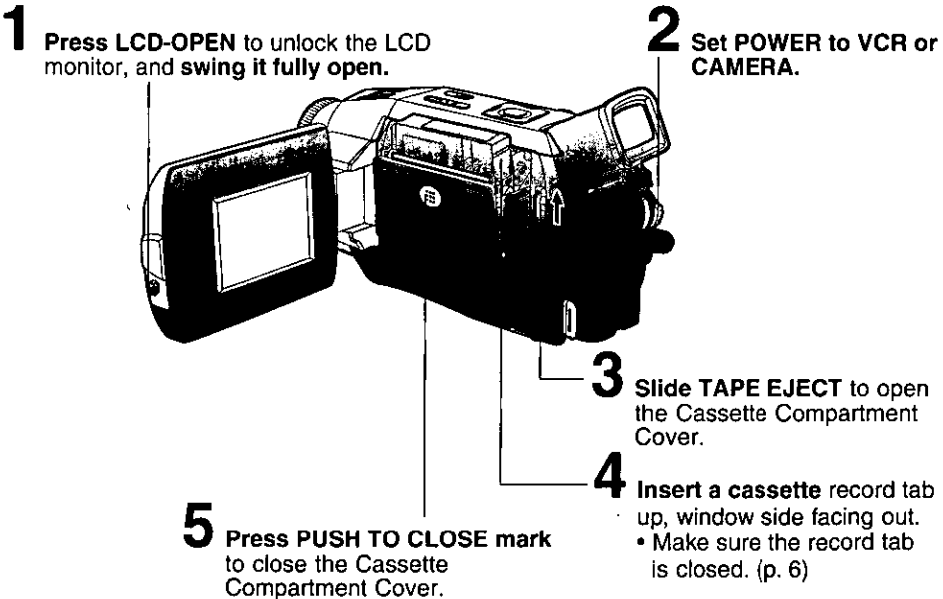

1 Press **LCD-OPEN** to unlock the LCD monitor, and swing it fully open.

2 Set **POWER** to **VCR** or **CAMERA**.

3 Slide **TAPE EJECT** to open the Cassette Compartment Cover.

4 Insert a cassette record tab up, window side facing out.

- Make sure the record tab is closed. (p. 6)

5 Press **PUSH TO CLOSE** mark to close the Cassette Compartment Cover.

Camera Recording

When the LCD monitor is fully open, the Viewfinder automatically turns OFF.

- 1** Set POWER to CAMERA.
- 2** Adjust the Vision Adjustment Control to your eyesight.
- 3** Press LCD-OPEN to unlock the LCD monitor. Swing it fully open and adjust the angle.
- 4** Press REC/PAUSE to start recording. Press REC/PAUSE again to pause recording.

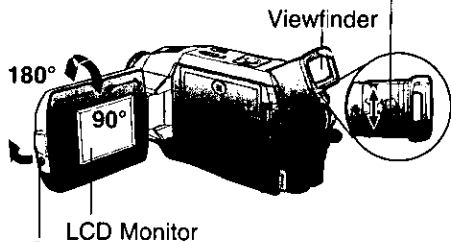
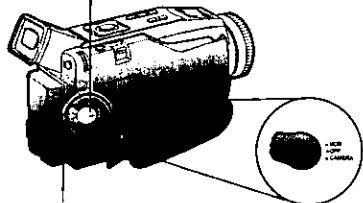

To Watch Playback in the LCD (Liquid Crystal Display)

When the LCD monitor is fully open, the Viewfinder automatically turns OFF.

Before you begin

- Charge the Battery. (p. 11)

- 1** Set POWER to VCR.
- 2** Press LCD-OPEN to unlock the LCD monitor. Swing it fully open and adjust the angle.
- 3** Press ◀ (REW) to rewind the tape.
- 4** Press ▶ (PLAY) to start playback.
- 5** Press ■ (STOP) to stop playback.

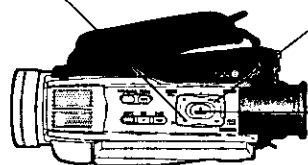
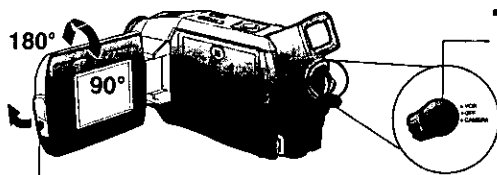

Charge the Battery Pack on the AC Adaptor

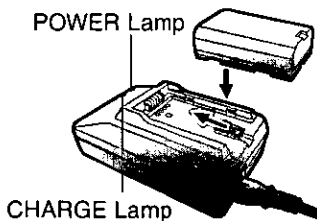
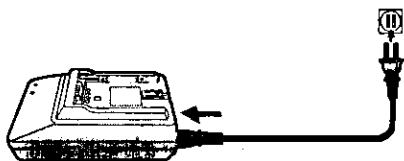

- 1** Connect and plug in the Power Cord as shown.
 - POWER Lamp will light.
 - Remove the DC Cable, if attached, from the adaptor.
- 2** Attach the Battery as shown to charge.
 - CHARGE Lamp lights up. It goes out when charging is complete (approx. 1 hour). Expect approx. 1 hour 30 minutes of operation (EVF usage) when fully charged.
- 3** Remove the Battery. Slide the Battery out and then lift up.

Note

About the Flashing of the CHARGE Lamp

- Charge the Battery within an ambient temperature range of 10 °C (50 °F) and 30 °C (86 °F).
- If charging is done in extreme low or high temperatures, Battery charge time increases.
- CHARGE Lamp flashes when...**
 - The Battery is being charged, but charging is taking longer than normal.
 - Charging is not possible. Remove the Battery once, wait a short time, then re-attach it for charging.

Insert the Battery Pack

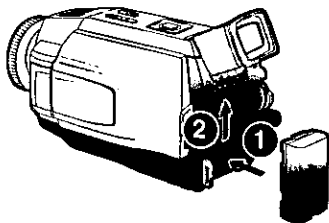

- 1** Insert the Battery Pack and slide it up until it locks with a click.

Remove the Battery Pack

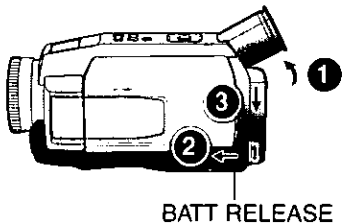

- 1** Tilt Viewfinder upward.
- 2** Remove the Battery Pack and slide the Battery downward while sliding the BATT RELEASE.

Battery Care

Caution:

- Charge only with specified charger.
- Charge the Battery within an ambient temperature range of 10 °C (50 °F) and 30 °C (86 °F).
- The Battery may be warm after charging or just after use. This is normal.
- Do not use an insufficiently charged or worn out Battery.
- If charging is done in extreme low or high temperatures, Battery charge time increases.

Safety precautions:

- Do not place the Battery near, or dispose of in fire.
- Do not directly connect (short circuit) the positive (+) and negative (-) terminals.
- Never attempt to disassemble or reassemble the Battery.

To avoid damage to the Battery:

- Do not drop or jar the Battery.
- Use the Battery with specified models only.
- If the Battery is used in extremely high temperatures, a safety device will automatically prevent operation.

To insure longer battery life:

- **While not in use, remove Battery from the Palmcorder and AC Adaptor and store in a cool, dark, dry place.** If you leave the Battery in the Palmcorder or on the AC Adaptor, the Battery will no longer be rechargeable.
- Keep the Battery terminals clean.

U.S.A. CONSUMERS: ATTENTION:



A lithium ion/polymer battery that is recyclable powers the product you have purchased. Please call 1-800-8-BATTERY for information on how to recycle this battery.

Use AC Adaptor

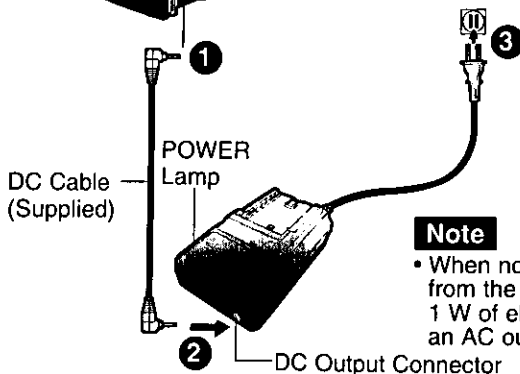
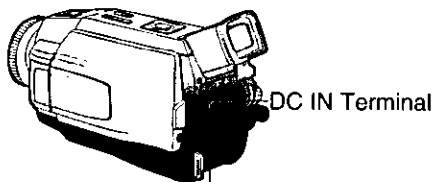

- 1 Slide the Battery downward while sliding the BATT RELEASE to remove the Battery Pack. (p. 11)
- 2 Insert the DC Cable into the DC IN Terminal.
- 3 Connect the other end of the DC Cable to the AC Adaptor as shown.
- 4 Plug in the AC Adaptor.
 - The POWER Lamp on the AC Adaptor lights up.

Note

- When not in use, unplug the AC Adaptor from the AC outlet. (AC Adaptor consumes 1 W of electric power when plugged into an AC outlet even when not in use.)

Set the Date and Time

The date and time is calculated, including leap year, up to DEC 31 2089.

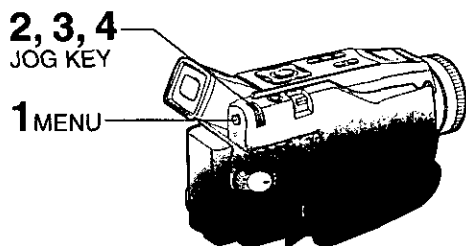

EXAMPLE:

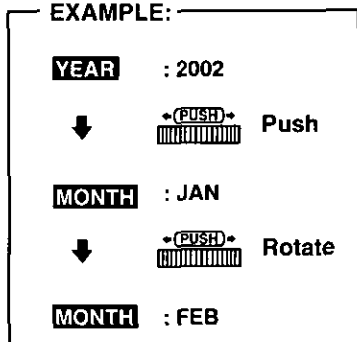

Note

- To make corrections, Press JOG KEY repeatedly to move back to an item and correct.
- A built-in Battery maintains clock operation. If the Palmcorder is not connected to a power source for a few months, the built-in battery may discharge and "CLOCK BATTERY" indication appears. (p. 53)

Before you begin

- Connect the Palmcorder to a power source. (pp. 11, 12)
- Set POWER to CAMERA or VCR.

- 1 Press **MENU** to display the Camera or VCR mode menu screen. (p. 14)

[CAMERA MENU]

CAMERA MENU	
1:FUNCTION	
2:ADJUST	
3:REC MODE	
4:SET-UP	
5:DISPLAY SETTING	
6:LCD/EVF SETTING	
↓	
-SELECT:ROTATE JOG KEY	
-SET :PUSH JOG KEY	
-EXIT :PUSH MENU KEY	

[VCR MENU]

VCR MENU	
1:PLAY FUNCTION	
2:REC MODE	
3:PLAY MODE	
4:MULTI SETTING	
5:DISPLAY SETTING	
6:LCD/EVF SETTING	
↓	
-SELECT:ROTATE JOG KEY	
-SET :PUSH JOG KEY	
-EXIT :PUSH MENU KEY	

- 2 Rotate **JOG KEY** to select **DISPLAY SETTING**, and then press **JOG KEY** to display the DISPLAY SETTING menu screen.

- 3 Rotate **JOG KEY** to select **CLOCK-SET**, and then press **JOG KEY** to set to ON. (Menu OSD: pp. 60, 62)
 - The DATE/TIME SETTING menu is displayed.

- 4 Rotate **JOG KEY** to select YEAR, then press **JOG KEY** to fix and move to the next item. Likewise, set the month, day, hour, and minutes.

DATE/TIME SETTING	
YEAR	: 2002
MONTH	: OCT
DAY	: 18
HOUR	: 5PM
MINUTE	: 10
↓	
-SELECT:ROTATE JOG KEY	
-SET :ROTATE JOG KEY	
-EXIT :PUSH MENU KEY	

When DATE/TIME setting is completed, press **MENU** three times to start the clock and exit.

Using the Palmcorder

The Palmcorder features two menu displays: one for CAMERA mode (recording) and the other for VCR mode (Playback). (pp. 59-62)

- While the Menu screen is displayed, you cannot record on or play a tape.
- While recording, the Menu screen cannot be displayed.
- During playback, the Menu screen can be displayed.

Before you begin

- Connect the Palmcorder to a power source. (pp. 11, 12)
- Set POWER to CAMERA or VCR.

2, A, B, C
JOG KEY

1, D
MENU

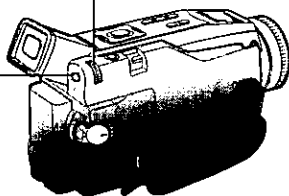

Displaying the MENU

1 Press **MENU** to display the CAMERA or VCR menu (according to the POWER setting).

2 Rotate **JOG KEY** to select a menu item.

Setting the MENU Items (EX. VCR Mode menu)

A Press **JOG KEY** to set your selection.

B Rotate **JOG KEY** to select a menu item.



C Press **JOG KEY** to set your selection.
• The "●" mark indicates selection.

D Press **MENU** twice to exit the menu.

CAMERA Main menu

- 1: D. FUNCTION**
CAMERA FUNCTION menu is displayed. To select D.FUNCTION, D.ZOOM, or PROGRESSIVE.
- 2: ADJUST**
CAMERA ADJUST menu is displayed.
To select PROG. AE or CINEMA.
- 3: REC MODE**
CAMERA REC-MODE menu is displayed. To select REC-SPEED, AUDIO-REC, INDEX, SHUTTER, or SELF-REC.
- 4: SET-UP**
CAMERA SET-UP menu is displayed.
To select BEEP.
- 5: DISPLAY SETTING**
DISPLAY SETTING menu is displayed.
To select DISPLAY, C.RESET, DATE/TIME, or CLOCK-SET.
- 6: LCD/EVF SETTING**
LCD/EVF SETTING menu is displayed.
To select LCD BRIGHTNESS, LCD COLOR or EVF BRIGHTNESS.

VCR Main menu

- 1: PLAY FUNCTION**
VCR PLAY FUNCTION menu is displayed. To select D. FUNCTION, D.EFFECT, or D.ZOOM.
- 2: REC MODE**
VCR REC MODE menu is displayed.
To select REC-SPEED or AUDIO-DUB.
- 3: PLAY MODE**
VCR PLAY MODE menu is displayed.
To select AUDIO or B.SEARCH.
- 4: MULTI SETTING**
MULTI SETTING menu is displayed.
To select SPEED.
- 5: DISPLAY SETTING**
DISPLAY SETTING menu is displayed.
To select DISPLAY, C.RESET, DATE/TIME, or CLOCK-SET.
- 6: LCD/EVF SETTING**
LCD/EVF SETTING menu is displayed.
To select LCD BRIGHTNESS, LCD COLOR or EVF BRIGHTNESS.

Simple Recording

Remove the lens cap and clip it to the hand strap.

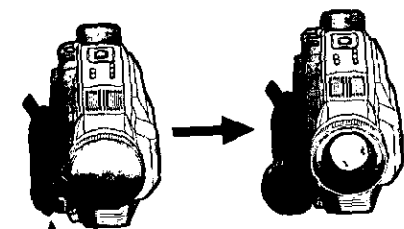

Clip here

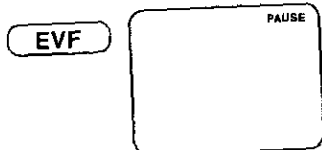

REC/PAUSE mode

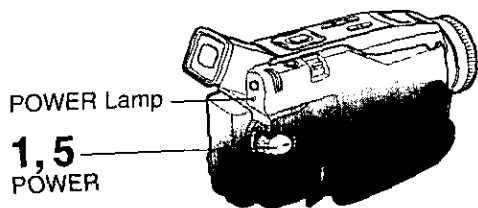

1, 5
POWER

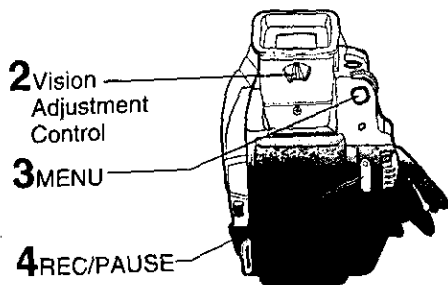

2 Vision
Adjustment
Control

3 MENU

4 REC/PAUSE

WARNING:

- Do not leave the Palmcorder with the EVF aimed directly at the sun as this may cause damage to the internal parts of the EVF.
- Do not lift, or carry, the Palmcorder by the EVF or the LCD Monitor.

Before you begin

- Connect the Palmcorder to a power source. (pp. 11, 12)
- Insert a cassette with the record tab closed. (p. 6)

- 1 Set POWER to CAMERA.**
 - The POWER Lamp lights red.
 - Be sure POWER is fully turned to the CAMERA position.
- 2 With the Viewfinder Eye Cup held up against your eye, adjust the Vision Adjustment Control to your eyesight.**
 - Adjust the EVF Brightness of the Viewfinder if necessary.
 - Please refer to "To adjust the LCD/ EVF BRIGHTNESS or COLOR" on page 16.
- 3 Set to REC-SPEED "SP" or "LP" in the CAMERA Mode Menu.**
(Menu OSD: p. 59)
- 4 Press REC/PAUSE to start recording.**
 - "REC" is displayed on the screen.
 - Press REC/PAUSE again to pause recording.
- 5 Set POWER to OFF when finished.**
 - To remove the cassette, slide TAPE EJECT.

- When the Palmcorder is aimed at excessively bright objects, or bright lights, a vertical bar may appear in the picture. This is a normal characteristic of the CCD pick-up device. Try to avoid this whenever possible.

To conserve power

After 5 minutes, the Record/Pause mode will automatically change to Standby mode.

To resume recording, set POWER to OFF and then ON again.

Using the LCD Monitor

The LCD (Liquid Crystal Display) monitor can be used while recording.

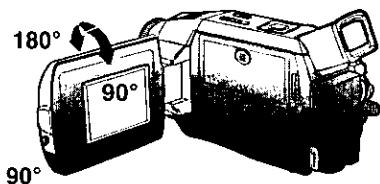
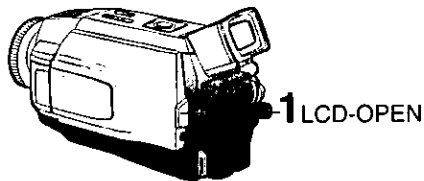

To adjust the LCD/EVF BRIGHTNESS or COLOR

1, 5
MENU

2, 3, 4
JOG KEY

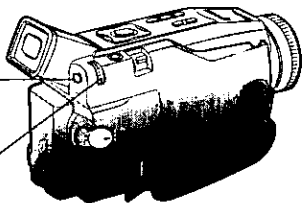

EVF/LCD

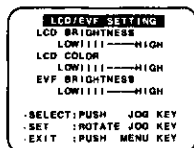

1 Press **LCD-OPEN** to unlock the LCD monitor.

2 Swing the LCD monitor fully open and adjust the viewing angle.

- The LCD monitor will automatically turn on.
- When the LCD monitor is completely closed, it will shut off automatically to save power.
- Adjust the LCD Brightness and/or color of the LCD monitor if necessary. Please refer to "To adjust the LCD/ EVF BRIGHTNESS or COLOR" below.

3 Start recording.

Note

- Using the LCD monitor will reduce battery operating time.
- Close the LCD monitor completely when not in use.

1 Press **MENU** to display the main menu screen.

2 Rotate **JOG KEY** to select **LCD/EVF SETTING** from the main menu screen. (Menu OSD: pp. 60, 62)

3 Press **JOG KEY** to display the LCD/ EVF SETTING screen.

4 Press **JOG KEY** to select LCD BRIGHTNESS, LCD COLOR, or EVF BRIGHTNESS, then rotate **JOG KEY** to adjust.

5 Press **MENU** twice to exit this mode.

Digital PhotoShot™ Mode

Use this feature to record a seven second (approx.) still image from the current camera picture. Audio is also recorded for on-the-spot narration. Or, you can add narration later with the Audio Dubbing feature to make an interesting slide show, etc. (p. 38)

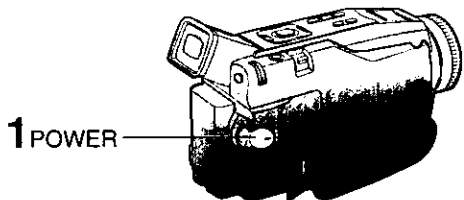

2 PHOTOSHOT

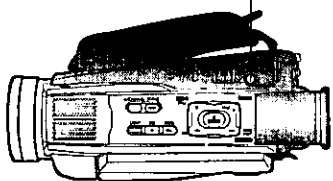

Progressive PhotoShot™ Mode

With the progressive PhotoShot Function, you can record still pictures with higher resolution than with the normal PhotoShot Function.

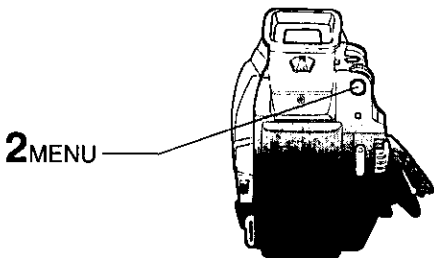
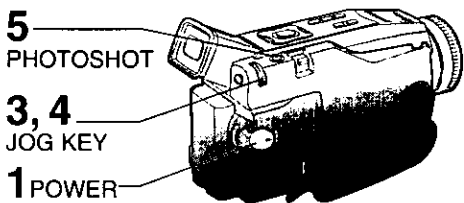

1 Set **POWER** to **CAMERA**.

2 Press **PHOTOSHOT** in Record/Pause mode. "PHOTO" will appear in the EVF or the LCD monitor.

EVF/LCD



Note

- If **SHUTTER** on the menu screen is set to **ON**, a sound effect similar to the shutter of a film camera will be heard when **PHOTOSHOT** is pressed.
- When **PHOTOSHOT** is pressed, the playback image takes approx. 7 seconds to process. After that, the Camera mode screen will be displayed.

1 Set **POWER** to **CAMERA**.

2 Press **MENU** to display the **CAMERA** mode menu screen.

3 Rotate **JOG KEY** to select **D.FUNCTION**, and press **JOG KEY** to display the **CAMERA FUNCTION** menu screen.

4 Rotate **JOG KEY** to select **PROGRESSIVE**, and press **JOG KEY** to select **ON** or **OFF**.

- Press **MENU** twice to exit.
- "P" will appear in the EVF or the LCD monitor.

5 Press **PHOTOSHOT** in Record/Pause mode.

EVF/LCD



Note

- This Function may not work with some function settings.

Zoom

You can gradually zoom in for close ups or zoom out for wide angle shots.

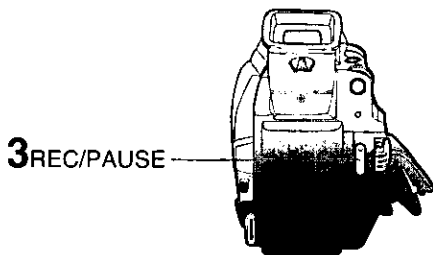
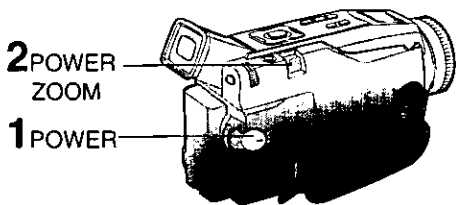

1 Set **POWER** to **CAMERA**.

2 **Zoom slowly:**
by lightly pressing the "T" (Telephoto) or the "W" (Wide Angle) side of the **POWER ZOOM**.

Zoom quickly:
by applying more pressure.

3 Start recording.

Note

- The zooming speed ranges from a slow 17 seconds to a fast 1.5 seconds according to the amount of pressure applied to the **POWER ZOOM**.

Recording Check

To playback the final few seconds of the last recorded scene in the **REC/PAUSE** mode.

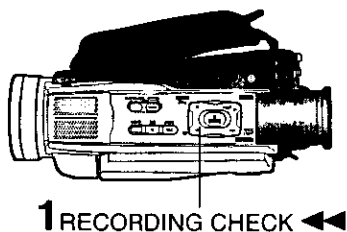

1 Press **RECORDING CHECK** ◀◀ briefly in the **REC/PAUSE** mode.

The **[CHK]** indication appears. After checking, the Palmcorder returns to the **REC/PAUSE** mode.

- For Recording Check, the Palmcorder must be in the same mode (**SP** or **LP**) as was used for recording, otherwise the playback picture is distorted.

Recording Still Pictures

You can record still pictures of any desired duration together with sound.



- 1 While in RECORD mode, **press STILL and hold for 2 seconds** to capture a still picture. The captured still picture will be recorded together with sound.
- 2 Press **STILL once again** to release the still picture. The camera will resume recording real-time pictures.

Self Recording

Rotate the LCD monitor 180 degrees so it faces the same direction as the lens to record yourself.

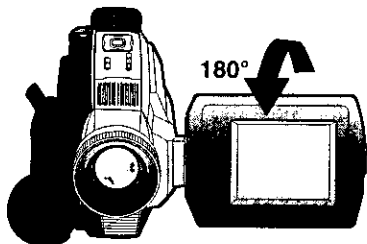
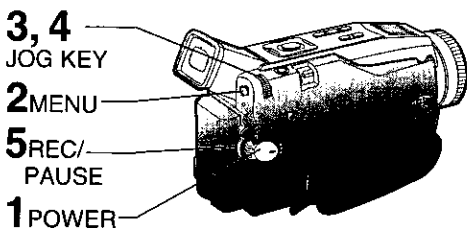

- 1 Set **POWER** to **CAMERA**.
- 2 Press **MENU** to display the **CAMERA** mode menu screen.
- 3 Rotate **JOG KEY** to select **REC MODE**, then press **JOG KEY** to display the **CAMERA REC-MODE** menu screen.
- 4 Rotate **JOG KEY** to select **SELF-REC**, and then press **JOG KEY** to select **MIRROR**.
 - The picture in the LCD monitor will appear reversed.
- 5 Start recording.

CINEMA Mode

You can record a picture compatible with a wide-screen TV equipped with an S2 picture terminal.

3, 4
JOG KEY

1 POWER

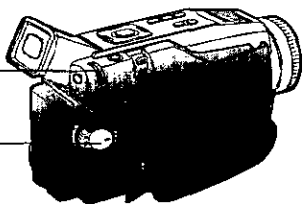

2 MENU

5 REC/PAUSE

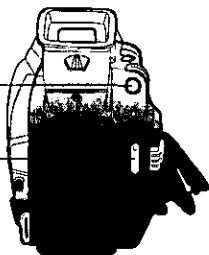

Backlight

Use when recording a subject that is darker than the surrounding scene, is in a shadowed area, or when the light source is in back of your subject.

1 POWER

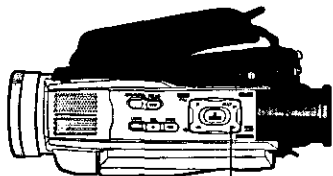
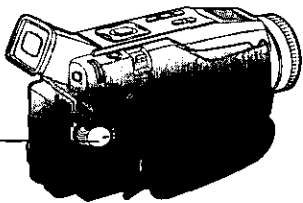

2, 3 BACK LIGHT

1 Set POWER to CAMERA.

2 Press MENU to display the CAMERA mode menu screen.

3 Rotate JOG KEY to select **ADJUST**, then press JOG KEY to display the CAMERA ADJUST menu screen.

4 Rotate JOG KEY to select **CINEMA**, and then press JOG KEY to select ON.

- A black strip will appear at the top and bottom of the picture.
- Press MENU twice to exit.
- "CINEMA" will appear on the screen.

5 Start recording.

EVF/LCD



1 Set POWER to CAMERA.

2 Press BACK LIGHT to activate the Backlight feature.

- The Indicator "●" will appear in the EVF or LCD monitor.

3 Press BACK LIGHT again to cancel the Backlight feature.

EVF/LCD

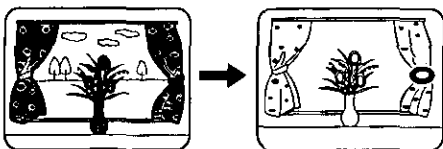

Note

- The Indicator "●" will not appear in the EVF or LCD monitor when OFF is selected in the DISPLAY menu.

Program AE

The Auto Exposure feature can be used to make quality recordings in a variety of scene situations.

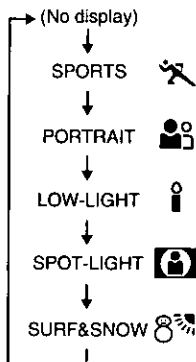
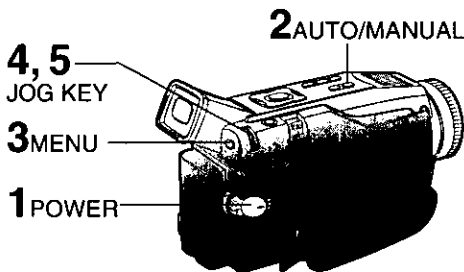

- 1** Set **POWER** to **CAMERA**.
- 2** Hold down **AUTO/MANUAL** for more than **0.7 seconds** so that the "MNL" indication appears in the EVF or the LCD monitor.
- 3** Press **MENU** to display the menu screen.
- 4** Rotate **JOG KEY** to select **ADJUST**, and then press **JOG KEY** to display the **CAMERA ADJUST** menu screen.
- 5** Rotate **JOG KEY** to select **PROG.AE**, then press **JOG KEY** repeatedly to select one of the five modes shown below.
- 6** Repeat steps 2-5 to select **OFF** to cancel this feature.

Camera

Mode	Indication
	For recording fast action scenes.
	For recording only subjects in the foreground, while ignoring subjects in the background.
	For recording in extreme low light conditions.
	Recording in situations where subjects are under a spotlight(s).
	For recording in locations with a high degree of "Dazzle," such as snow slopes and the seashore.

Note

SPORTS mode

- The recorded images will not be so blurred when they are viewed later using slow or still picture playback.
- When playing back a sports mode recording, the movement may appear slightly jerky.
- Do not use this mode when recording under fluorescent, mercury, or sodium lighting. These types of lights will affect the color and brightness of the images.
- A vertical band of light might appear when recording objects that are brightly illuminated or highly reflective.
- If the amount of light is insufficient, the SPORTS "X" indicator will flash in the EVF or the LCD monitor.
- The image may flicker if this mode is used indoors.

PORTRAIT mode

- The image may flicker if this mode is used indoors.

LOW-LIGHT mode

- Scenes recorded in extremely low light levels may not come out properly.

SPOT-LIGHT mode

- If the recorded subject is extremely bright, the picture may appear whitish.

SURF&SNOW mode

- If the recorded subject is extremely bright, the picture may appear whitish.
- It is not possible to select the SPORTS mode or PORTRAIT mode together with the MagicPix mode in the Digital function camera menu.

Audio/Video Fade In/Out

You can make smoother scene transitions for a more professional look.

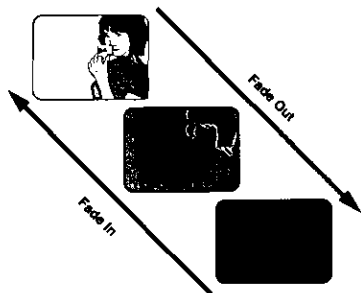
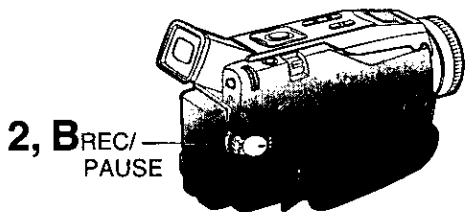

Fade In

Starting the first scene with "fade in" is very effective.

- 1** In REC/PAUSE mode, hold down **FADE** until the picture fades out.
- 2** Press **REC/PAUSE** to start recording.
- 3** Release **FADE** and the picture will gradually fade in.

Fade Out

Use to create a soft ending or (together with fade in) for a soft transition from one scene to the next.

- A** During recording, hold down **FADE** until the picture fades out.
- B** Press **REC/PAUSE** to pause the recording.

Picture in Picture (PiP)

You can display a PiP (still image) screen on the Main Picture.

Note

- PiP position is fixed at the bottom right of the screen.

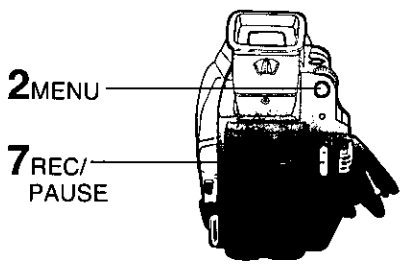
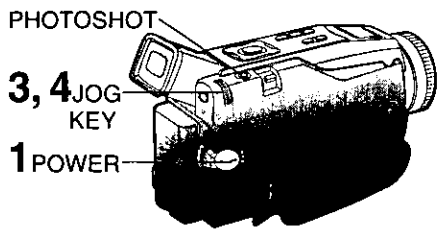
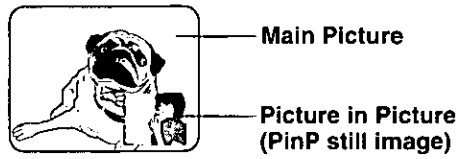

5, 6, 7
CAMERA STILL

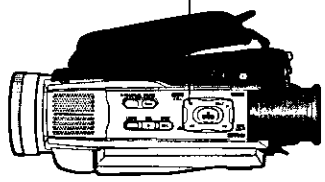

- 1 Set **POWER** to **CAMERA**.
- 2 Press **MENU** to display the menu screen.
- 3 Rotate **JOG KEY** repeatedly to select **D.FUNCTION**, then press **JOG KEY** to display the **CAMERA FUNCTION** menu screen.
- 4 Press **JOG KEY** to select **PiP**.
 - Press **MENU** twice to exit this menu.
 - "PiP" will appear in the EVF or the LCD monitor.

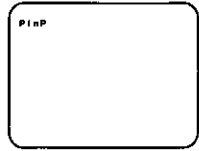

- 5 Aim at the scene you wish to place as PiP, then press **II (CAMERA STILL)** to freeze the image.
- 6 Press **II (CAMERA STILL)** again to place the frozen image as PiP.



- 7 Press **REC/PAUSE** to record a scene with PiP image.
 - Press **PHOTOSHOT** to record a scene with PiP image in PhotoShot mode.
 - Press **II (CAMERA STILL)** again to remove PiP image.

Camera

White Balance

Auto White Balance ("AWB") automatically maintains optimum color balance in most lighting conditions. However, when using Digital Functions, etc., you may get better results by using the manual adjustment.

3, 4, A, B
JOG KEY

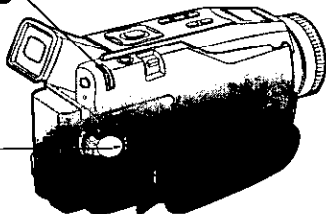

1 POWER

2 AUTO/MANUAL

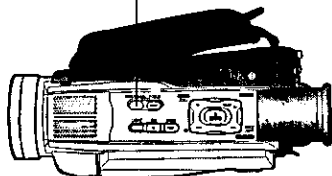

Mode	Description
AWB	Automatically maintains optimum color balance in most lighting conditions.
☉	When the source illumination is a halogen lamp.
☀	When shooting outdoors on a sunny day.
* [AWB icon]	The White Balance setting that was previously set manually.

Note

- When ZOOM is set to 10X or higher, White Balance cannot be adjusted.

- 1** Set **POWER** to **CAMERA**.
- 2** Hold down **AUTO/MANUAL** for more than **0.7 seconds** so that the "MNL" indication appears in the EVF or the LCD monitor.
- 3** Press **JOG KEY** repeatedly until "AWB" appears in the EVF or LCD monitor.
- 4** Rotate **JOG KEY** to select other modes. (See mode chart at left.)
 - Hold down **AUTO/MANUAL** for more than **0.7 seconds** to cancel the setting.

* For manual White Balance adjustment:

A. Rotate **JOG KEY** to select "[AWB icon]".

B. Point the Palmcorder at a white object (full-screen) and hold **JOG KEY** down until "[AWB icon]" indication stops flashing.

- If "[AWB icon]" indication flashes when the Palmcorder is turned on, the previous manual White Balance setting is in effect.

In the following cases, the "[AWB icon]" indication flashes:

- The flashing indicates that the previously adjusted White Balance setting is still kept. This setting will be kept until White Balance is adjusted again.
- Correct White Balance may not be attainable manually in poor lighting.

Auto Focus

The Palmcorder automatically adjusts the focus over the entire zoom range.

Manual Focus

Use Manual Focus (MF) when recording ...

- a subject through glass.
 - a scene where the subject is far from the Palmcorder and there are objects in the foreground.
 - a subject with distinct horizontal stripes.
 - a subject not centered in the Viewfinder.
 - subjects with shiny surfaces.
 - an obliquely angled subject.
 - a bright, flat subject such as a white wall.
 - in low light situations.
 - a scene with fast motions, like a golf swing.
- Re-focusing may be required**
- when your Palmcorder is aimed at a new scene.

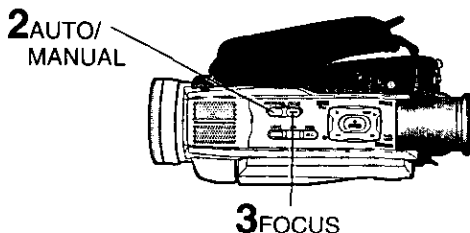
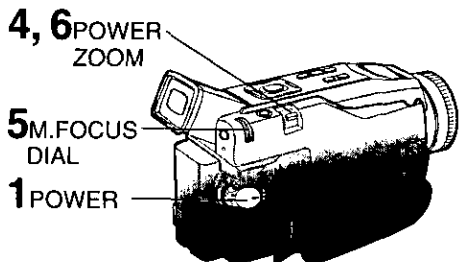

- 1 Set **POWER** to **CAMERA**.
- 2 Hold down **AUTO/MANUAL** for more than **0.7 seconds** so that the "MNL" indication appears in the EVF or the LCD monitor.
- 3 Press **FOCUS** so that the "MF" (Manual Focus) indication appears in the EVF or the LCD monitor.
- 4 Press and hold **POWER ZOOM**, "**T**" side (**Telephoto**), until the lens is at maximum zoom in.
- 5 Turn **M.FOCUS DIAL** until the picture is in focus.
 - It may be necessary to back away from the subject to focus the image properly.
- 6 Press **POWER ZOOM** to "**W**" or "**T**" as desired.
 - The subject will remain in focus over the entire zooming range.
 - It may be necessary to back away from the subject to focus the image properly.

Note

- **DISPLAY** must be set to on for MF, AE, W.BALANCE, or BACK LIGHT to be displayed on the LCD or EVF.

Macro Focus (for close-ups)

Press the "**W**" side of **POWER ZOOM** to the maximum wide angle position.

Auto Focus will function with the subject as close as 25 mm (1 inch) in front of the lens.

High Speed Shutter

To record high speed motion (e.g. tennis stroke) with improved STILL or SLOW MOTION playback when watching the tape on this Palmcorder.

Auto Shutter

In the AUTO mode (no indication in the EVF and LCD monitor), the Palmcorder will automatically adjust the shutter speed (up to 1/350).

- AUTO mode is automatically selected whenever the POWER Switch is set to CAMERA.

Manual Selection

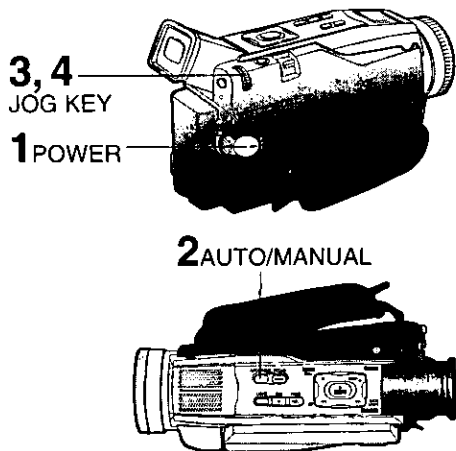

- 1** Set POWER to CAMERA.
- 2** Hold down AUTO/MANUAL for more than 0.7 seconds so that the "MNL" indication appears in the EVF or the LCD monitor.
- 3** Press JOG KEY repeatedly to display the shutter speed.
- 4** Rotate JOG KEY to choose one of the following shutter speeds.
 - Hold down AUTO/MANUAL for more than 0.7 seconds to cancel the setting.

EVF/LCD

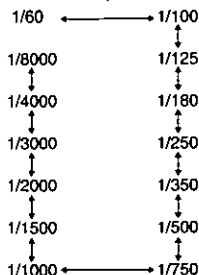
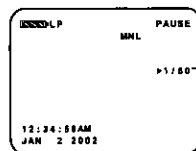

Note

- For proper color reproduction, it is recommended that you use this feature outdoors. For indoor High Speed Shutter recording, additional halogen or tungsten light should be provided. Fluorescent light will degrade the picture quality.
- This feature requires ample light. More light is required for the fastest shutter speeds.
- The Auto Focus system may not operate properly in insufficient light when using the High Speed Shutter.
- When PROG.AE is ON, you cannot manually select the shutter speed.
- When MagicPix is ON, H.S.S. cannot manually select the shutter speed.

Adjusting the Iris Manually

Normally, the Palmcorder adjusts the exposure automatically. However, when the background is extremely bright, or when the subject is backlit, you can compensate by adjusting the Iris manually.

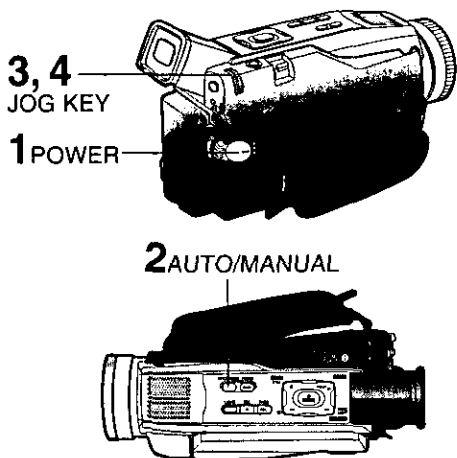

EVF/LCD

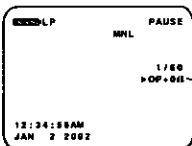

Iris
Setting

- 1** Set **POWER** to **CAMERA**.
- 2** Hold down **AUTO/MANUAL** for more than **0.7 seconds** so that the "MNL" indication appears in the EVF or the LCD monitor.
- 3** Press **JOG KEY** repeatedly so that Iris setting indication appears in the EVF or the LCD monitor.
- 4** Rotate **JOG KEY** to adjust the iris;
 - When a value closer to "CLOSE" is selected, the image becomes darker.
 - When a value closer to "OP+18dB" is selected, the image becomes brighter.
 - Hold down **AUTO/MANUAL** for more than 0.7 seconds to cancel the setting.

Note

- The value to which +dB is attached indicates a gain value. If this value is too large, the quality of the image deteriorates.
- Depending on ZOOM magnification, the iris value may not be displayed correctly.
- If you are using Program AE mode, you cannot adjust the iris. If the iris is adjusted manually, the above modes will be canceled.

Playback using the LCD Monitor

You can also use the LCD monitor to playback your recording.

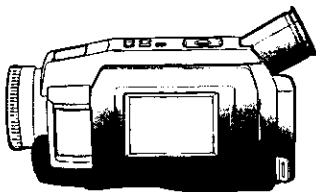
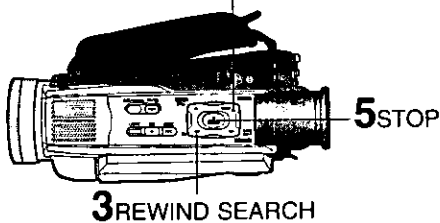
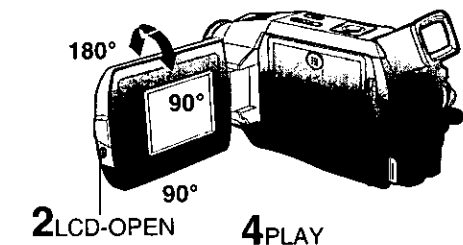
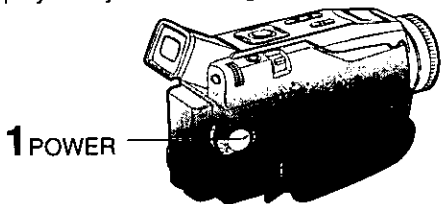

Before you begin

- Connect the Palmcorder to a power source. (pp. 11, 12)
- Insert a recorded cassette.

- 1** Set the **POWER** to **VCR**.
 - The **POWER** lamp lights red.
 - Be sure **POWER** is fully turned to the **VCR** position.
- 2** Press **LCD-OPEN** to unlock the LCD monitor and swing open.
- 3** Press **◀ (REWIND/SEARCH)** to rewind the tape.
- 4** Press **▶ (PLAY)** to start playback.
- 5** Press **■ (STOP)** to stop playback.
 - When the tape reaches its beginning during rewind or rewind search, it will stop automatically.

Note

- When a tape recorded in LP mode on another digital video camera is played back on this unit, the picture may appear mosaic.
- Using the LCD monitor reduces battery operating time.
- You can place the Palmcorder on a table, etc. for viewing. Rotate the LCD Monitor 180° and swing it up against the Palmcorder body as shown.

Connecting Earphone (not supplied)

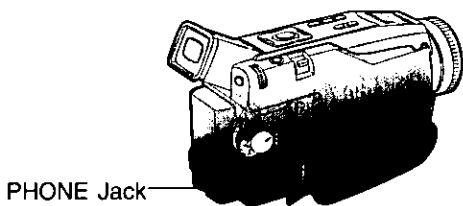

You can connect earphones (not supplied) to the **PHONE** Jack.

Repeat Playback

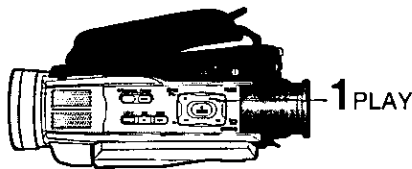

EVF/LCD

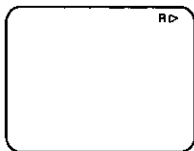

1 Press **PLAY** for more than 5 seconds in **STOP** mode.

- The Palmcorder will go into Repeat Playback mode when the tape reaches its end.
- The letter "R ▷" will appear in the EVF and LCD monitor.

2 Turn the Palmcorder **OFF** to exit the Repeat Playback mode.

Adjusting the Volume

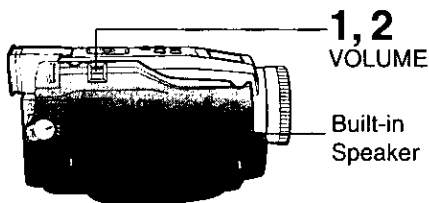

EVF/LCD

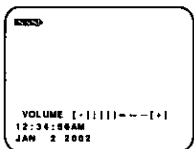

1 Rotate **VOLUME** to adjust the volume of the built-in speaker in **PLAY** mode.

- The volume setting screen appears.

2 Press "**T**" to increase the volume or press "**W**" to decrease the volume.

Blank Search

You can go directly to a blank portion of tape and start recording exactly where you left off.

3, 4, 5
JOG KEY

2 MENU

1 POWER

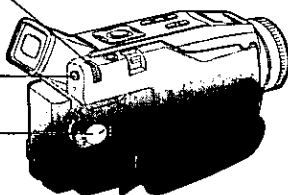

EVF/LCD

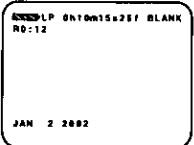

1 Set **POWER** to **VCR**.

2 Press **MENU** to display the VCR mode menu screen.

3 Rotate **JOG KEY** to select **PLAY MODE**, then press **JOG KEY** to display the VCR **PLAY MODE** menu screen.

4 Rotate **JOG KEY** to select **B.SEARCH** in the VCR **PLAY MODE** menu. (Menu OSD: p. 61)

5 Press **JOG KEY** to select **ON**.
• "BLANK" will appear on the screen.

Note

- Sound is muted during all special effects.

Rapid Visual Search

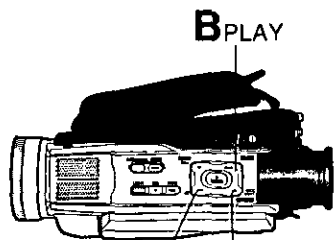

A, B REWIND/SEARCH A, B FAST FORWARD/SEARCH

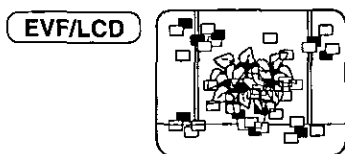

A During playback, hold down ►► (FAST FORWARD/SEARCH) or ◀◀ (REWIND/SEARCH).
The search will continue for as long as the button is held down.

OR

B Press ►► (FAST FORWARD/SEARCH) or ◀◀ (REWIND/SEARCH) once for a continuous rapid visual search.
Press ► (PLAY) to release.

Note

- When executing a rapid visual search, the picture may become bluish for an instant or mosaic. This is normal during this mode.

STILL Picture

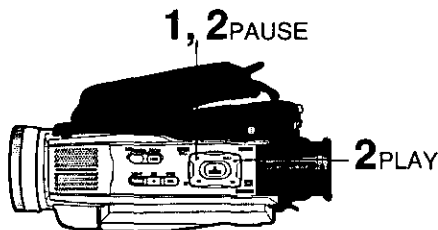

- 1** Press II (PAUSE) during playback.
- 2** Press ► (PLAY) or II (PAUSE) to release.

Note

- To protect the tape and video heads, your Palmcorder's operating modes will revert as follows:
STILL → STOP (after 3 minutes.)

Fast Forward/Rewind Check

Monitor normal picture playback during fast forward or rewind.

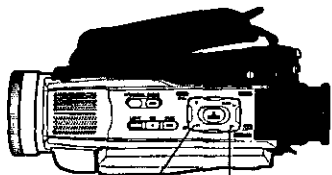

B REWIND/SEARCH A FAST FORWARD/SEARCH

A Hold down ►► (FAST FORWARD/SEARCH) during fast forward.

B Hold down ◀◀ (REWIND/SEARCH) during rewind.

- The picture will appear for as long as the button is held down.

Note

- Sound is muted during all special effects.

Variable Speed Search

2, 3
JOG KEY

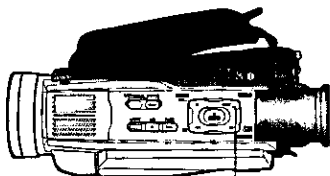
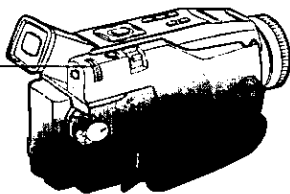

1 PLAY

- 1 Press ► (PLAY) to start playback.
- 2 Press JOG KEY for about 1 second.
- 3 Rotate JOG KEY to adjust the playback speed.
 - Rotate JOG KEY clockwise for forward playback.
 - Rotate JOG KEY counterclockwise for reverse playback.

To return to normal playback:

Press ► (PLAY). Playback will continue at normal speed.

Note

- The Variable Speed Search function offers a choice of six playback speeds (1/5X (LP mode: 1/3X), 1X, 2X, 5X, 10X, 20X) both in forward and reverse directions.
- The review playback at the 1X speed is playback in reverse direction.
- During the Variable Speed Search (at a speed other than 1X), mosaic-like patterns will appear in the picture.
- During the Variable Speed Search, sound is muted.

Jog Frame by Frame Search

JOG KEY

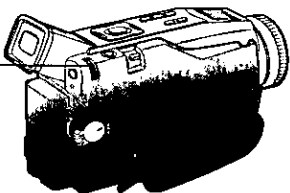

During Still mode, rotate JOG KEY to advance or reverse the picture one frame at a time.

Strobe Multi Mode

In Strobe Multi Mode, you can select the rate at which a succession of still screens are captured from the playback picture.

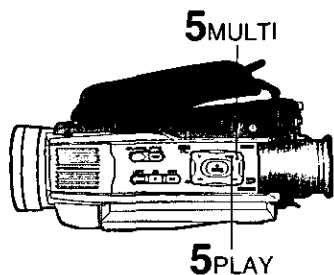
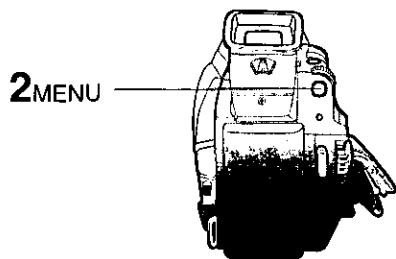
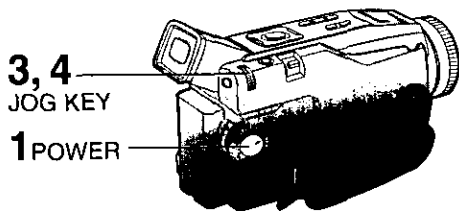

Note

- A Multi Image Playback screen cannot be output from the DV terminal or Digital Still Image terminal.
- A Multi screen will have slightly lower image quality.

- 1 Set **POWER** to **VCR**.
- 2 Press **MENU** to display the menu screen.
- 3 Rotate and press **JOG KEY** to select and set **MULTI SETTING**.
- 4 Press **JOG KEY** repeatedly to set desired speed.

Strobe Speeds

Strobe Speeds 9 screen capture time

FAST	Every 0.3 seconds
NORM	Every 0.6 seconds
SLOW	Every 1.0 seconds

- Press **MENU** twice to exit.

- 5 Press **▶ (PLAY)** to start playback. Press **▶ (MULTI)** at the point you want to start capturing.
 - A succession of 9 screens will be captured, and playback will stop.

EVF/LCD

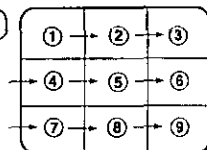

- Press **▶ (PLAY)** to start playback. Press **■ (STOP)** to stop playback.

View Recording/Playback on your TV

[TV with AUDIO/VIDEO IN Jacks]

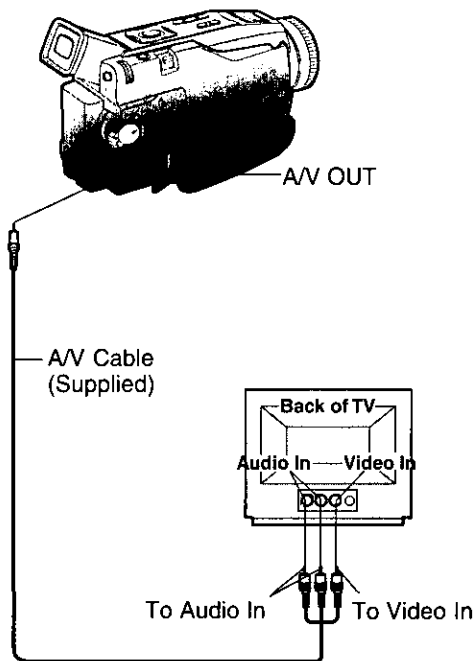

1 Set **POWER** to **CAMERA** or **VCR**.
To view what the Palmcorder is recording or to playback a tape on your TV.

2 Turn your TV **ON** and set it to **LINE INPUT**.
Check your TV operating instructions for further information.

3 Start playback or begin a recording.

- Make sure the Palmcorder and TV are turned off while connecting.
- Please connect the A/V Cable securely.

VCR

Digital Features

Digital Zoom

This feature is useful when you want to record close-up shots of subjects located beyond a normal zoom range of 1X to 10X magnification. With the digital zooming feature, you can select a magnification of 25X or even to 700X.

Note

- Other Digital Functions are turned off automatically when the EIS and Digital Zoom are selected.

EVF/LCD

Zoom In ("T")



Zoom Out ("W")

5 POWER ZOOM

3, 4 JOG KEY

1 POWER

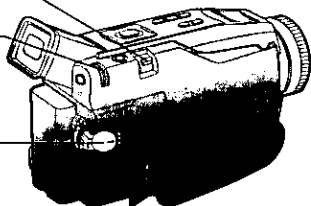

2 MENU

5 REC/PAUSE

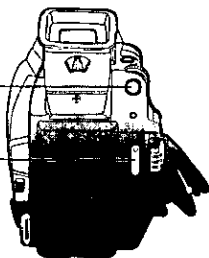

CAMERA mode

- 1 Set **POWER** to **CAMERA**.
- 2 Press **MENU** to display the **CAMERA MENU** screen.
- 3 Rotate **JOG KEY** to select **D.FUNCTION**, then press **JOG KEY** to display the **CAMERA FUNCTION** menu screen.
- 4 Rotate **JOG KEY** to select **D.ZOOM**, then press **JOG KEY** to select **D.ZOOM1** or **D.ZOOM2**.
 - D.ZOOM1 : from 10X to 25X
 - D.ZOOM2 : from 10X to 700X
 - OFF : Turn off D.ZOOM• Press **MENU** twice to exit.
- 5 Press **REC/PAUSE** to start recording and press **POWER ZOOM** to zoom in or zoom out.
 - The magnification level is always displayed in the EVF or the LCD monitor when **DISPLAY** is set to **ON**. (Menu OSD: pp. 60, 62)
- 6 Repeat steps 2~4 to select **OFF** to cancel this feature.

Note

- The normal optical zoom functions from 1X to 10X.
- As magnification increases, resolution significantly decreases.
- Because the image is enlarged digitally, the picture may become distorted when higher magnification levels are used.
- When the level falls below 10X, the normal zooming function will resume.
- Focus distance becomes 1.2 m (4 feet) if the lens is in full telephoto.

Digital Zoom (Continued)

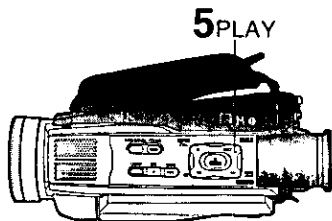
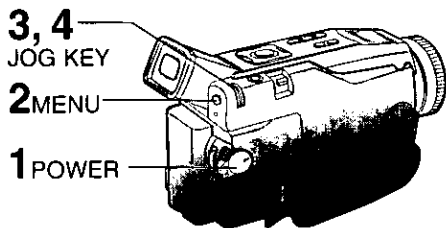

VCR mode

- 1 Set POWER to VCR.
- 2 Press MENU to display the VCR MENU screen.
- 3 Rotate JOG KEY to select **PLAY FUNCTION**, then press JOG KEY to display the VCR PLAY FUNCTION menu screen.
- 4 Rotate JOG KEY to select **D.ZOOM**, then press JOG KEY to select ON.
 - Press MENU twice to exit.
- 5 Press ► (PLAY) to start playback.
 - The center portion of the image doubles in size.
- 6 Repeat steps 2~4 to select OFF to cancel this feature.

MagicPix™ Images

Color recording of video or still images onto the Mini DV tape in low lighting. (pp. 37, 59)

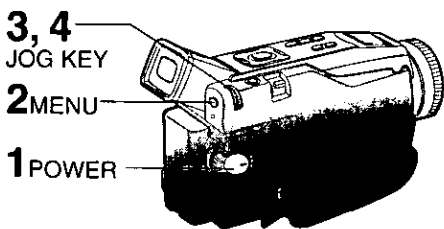

EVF/LCD

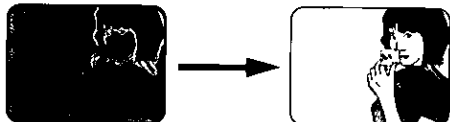

- 1 Set POWER to CAMERA.
- 2 Press MENU to display the menu screen.
- 3 Rotate JOG KEY to select **D.FUNCTION**, and then press JOG KEY to display the CAMERA FUNCTION menu screen.
- 4 Rotate JOG KEY to select **D.FUNCTION**, and then press JOG KEY repeatedly to select MAGICPIX.
 - Press MENU twice to exit.
- 5 To cancel the Digital Function, press JOG KEY repeatedly to select OFF.

Dual Digital Electronic Image Stabilization System (D.E.I.S.)

This feature helps compensate for any unintentional hand or body movement. It can be used in both the Recording and Playback (VCR) modes.

Note

- Other Digital Functions are turned off automatically when the EIS and Digital Zoom are selected.

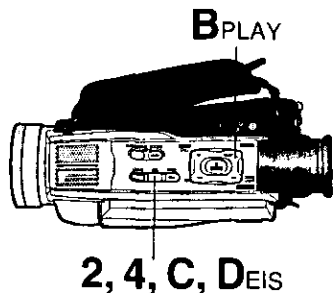
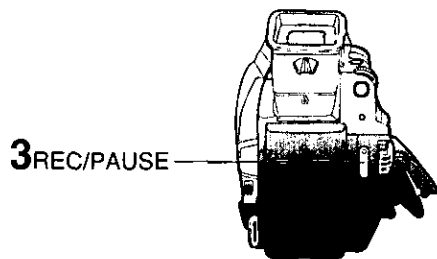
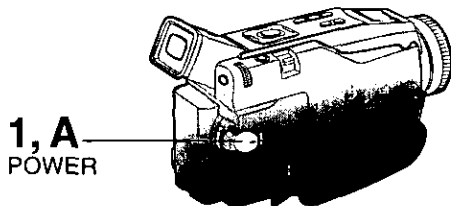
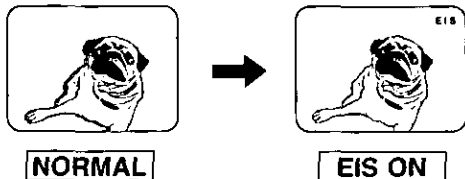

CAMERA mode

- 1** Set **POWER** to **CAMERA**.
- 2** Press **EIS** to stabilize the picture.
 - Picture flicker may be observed when taping under fluorescent lighting conditions.
 - The EIS indicator flashes when the light level is inadequate.
 - Turn D.E.I.S. OFF during recording when using a tripod.
- 3** Press **REC/PAUSE** to start recording.
- 4** Press **EIS** again to cancel.
 - Be sure that D.E.I.S. is turned off when not needed.

D.E.I.S. may not function when...

- Palmcorder movement is too extreme.
- Recording a subject with distinct horizontal or vertical stripes.
- Recording in low light situations.
- Recording a subject under a great amount of fluorescent light.
- Recording a scene with very fast motions.

VCR mode

- A** Set **POWER** to **VCR**.
- B** Press **▶ (PLAY)** to start playback.
- C** Press **EIS** to stabilize the picture.
- D** Press **EIS** again to cancel.
 - Be sure that D.E.I.S. is turned off when not needed.

Note

- When using D.E.I.S. in VCR mode, the image size is slightly larger.

Other Digital Functions

Use the following features to add interest and professionalism to your recordings or playback. Select from twelve special effects.

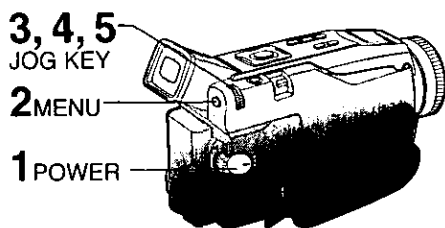

Types of Digital Functions

MIRROR

Symmetrical image from the current camera picture.

STROBE

The recording appears as a sequence of still frames.

MOSAIC

The picture appears in a mosaic pattern.

SLIM

The picture is expanded vertically.

TRAIL

The subject being recorded creates a trail when in motion.

STRETCH

The picture is expanded horizontally.

MAGICPIX (Not available during playback)

Color recording of video or still images onto the Mini DV in low lighting. (p. 35)

• Only Manual Focus is available.

WIPE

Successive scenes are separated in a way which simulates the drawing of a curtain.

MIX

The current scene is mixed in with the following scene during scene changes.

PinP

PinP (Still image) is displayed on the Main Picture.

SEPIA (Only available during playback)

The picture is played back in sepia, a brownish color, giving it an antique look.

MONO (Monotone) (Only available during playback)

The picture is played back in black-and-white.

1 Set **POWER** to **CAMERA** or **VCR**.

2 Press **MENU** to display the menu screen.

3 Rotate **JOG KEY** to select **D.FUNCTION** in the **CAMERA** mode menu screen or **PLAY FUNCTION** in the **VCR** mode menu screen, then press **JOG KEY** to display the **CAMERA FUNCTION** or **VCR PLAY FUNCTION** menu screen.

4 Rotate **JOG KEY** to select **D.FUNCTION**, and then press **JOG KEY** repeatedly to select one of the Digital Functions listed on the left.

5 To cancel the Digital Function, press **JOG KEY** repeatedly to select **OFF**.

Note

• The **EIS** and **Digital Zoom** features are turned off automatically when one of the Digital Functions listed at left is selected.

To use the WIPE function

- In Camera mode, set the "D.FUNCTION" item in the main menu screen to "WIPE". (Menu OSD: p. 59)
- Press **REC/PAUSE** to start recording.
- Press **REC/PAUSE** to pause the recording. The last scene will be memorized.
- Press **RECORD/PAUSE** to start recording again. The new scene will take the place of the memorized scene.

To use the MIX function

- In Camera mode, set the "D.FUNCTION" item in the main menu screen to "MIX" (Menu OSD: p. 59). Then, perform steps **b-d** above.

The memorized scene and the new scene will appear mixed as the scene changes from one to the other.

Audio Dubbing using the Built-in Microphone

The original sound can be replaced with new sound using the built-in Palmcorder microphone.

Built-in Microphone

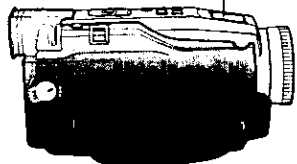

4, 5
JOG KEY

3
MENU

1
POWER

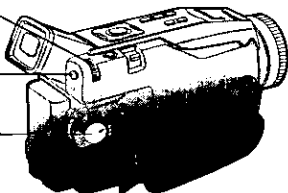

2
PLAY

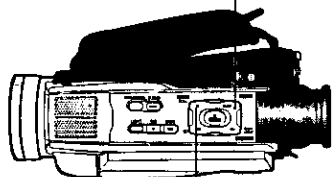

2
PAUSE



Before you begin

- Turn on the Palmcorder.
- Insert a pre-recorded tape to be dubbed.

The AUDIO-REC setting in CAMERA MENU mode should be as follows:

12 bit	The original sound is recorded on ST (Stereo) 1, and the new sound will be recorded on ST (Stereo) 2.
16 bit	The original sound is replaced with the new sound.

- Select 12 bit if you do not want the original sound to be completely replaced during an audio dub.
- If you dub over a tape which has both 12 bit and 16 bit audio recordings on it, keep in mind that the original 16 bit audio portion will be completely replaced.

1 Set **POWER** to **VCR**.

2 Press **▶ (PLAY)**. Then press **⏸ (PAUSE)** where you want dubbing to begin.

3 Press **MENU** to display the VCR mode menu screen.

4 Rotate **JOG KEY** to select **REC MODE**, then press **JOG KEY** to display the VCR REC MODE menu screen.

5 Rotate **JOG KEY** to select **AUDIO-DUB**, and then press **JOG KEY** to select ON.

- The Palmcorder will go to Stand By mode, and "A.DUB" flashes in the EVF or the LCD monitor.

6, 7 PAUSE

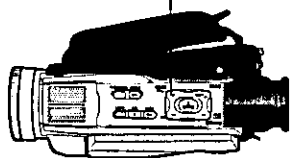

To listen to the desired audio sound, set the AUDIO setting of the VCR mode MENU (Menu OSD: p. 61) as follows:

AUDIO:The following selections are available for 12 bit AUDIO dubbed recordings only (sound recorded in SP mode only).

ST 1	Set this position to listen to the original sound.
ST 2	Set this position to listen to the audio dubbed sound.
MIX	Set this position to listen to both the original sound and the audio dubbed sound.

Note

- 16 bit dubbed sound completely erases the original 16 bit recorded sound.
- If you dubbed using 12 bit AUDIO recording and then selected AUDIO-MIX in the menu for playback, the sound will be stereo regardless of the AUDIO-OUT setting.
- If you recorded in LP mode, you cannot use the A.DUB feature.

6 Press **II (PAUSE)** to start Audio Dubbing.

- Connect the Palmcorder to the TV in order to monitor the sound.
(p. 33)

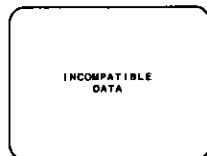

Only NTSC (National Television Standards Committee) recorded tapes can be audio dubbed. The following screen appears if the tape was not recorded in NTSC format.

7 Press **II (PAUSE)** to stop Audio Dubbing.

- If the microphone used for dubbing gets too near the speaker of your TV, a howling noise (feedback) may occur.
- If the tape position is in or was started in a blank section, you cannot use the A.DUB feature.

Copying your Tapes to VHS Cassette

Source (Playing)
Palmcorder

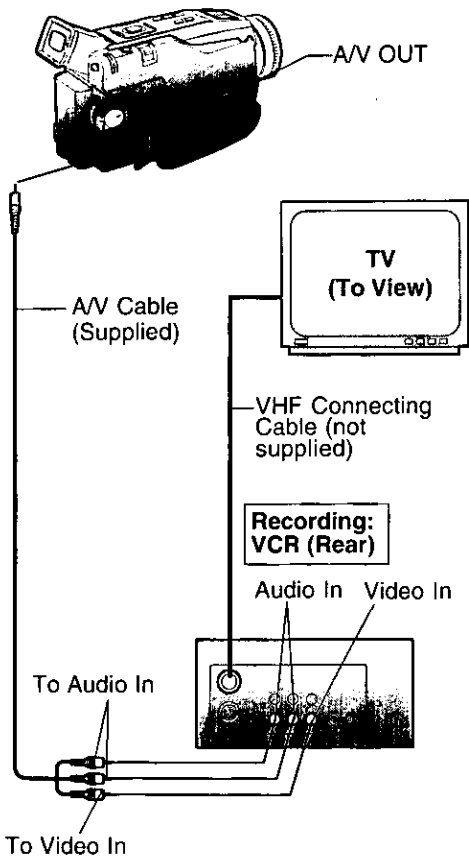

Before you begin

- Connect both Palmcorder and VCR to their power sources.
- Connect the Palmcorder to a VCR as illustrated left.
- Turn ON both units.
- **Set the recording VCR's Input Signal Selector to LINE.**
- Set the Palmcorder POWER to VCR.

- 1** Insert a pre-recorded tape into the source (playing) Palmcorder and a blank tape, with record tab in place, into the target VCR (Recorder).
- 2** Press ► (PLAY) on the Palmcorder. When the tape reaches the point you want to start dubbing, press PAUSE.
- 3** Place the VCR into REC/PAUSE mode. (See VCR manual.)
- 4** Simultaneously, press PAUSE on both units to begin copying.
- 5** Press STOP on both units when copying is completed.

Note

- For technical reasons, dubbing a tape may reduce its quality.
- If the Time Code is displayed in the EVF or LCD monitor, it cannot be reset.
- Only the DATE/TIME, when displayed, will be recorded on the tape.

Monitor with your TV

- Turn the TV ON and select its VCR channel (either CH3 or CH4).
- Set the VCR/TV Selector on the recording VCR to VCR.

CAUTION:
Unauthorized exchanging and/or copying of copyrighted recordings may be copyright infringement.

Copying from Digital Equipment (dubbing)

High quality digital-to-digital copying can be accomplished if both Palmcoders incorporate the DV Input/Output (i.LINK) Connector (DV interface cable (i.LINK) is not supplied).

Source (Playing) Palmcorder

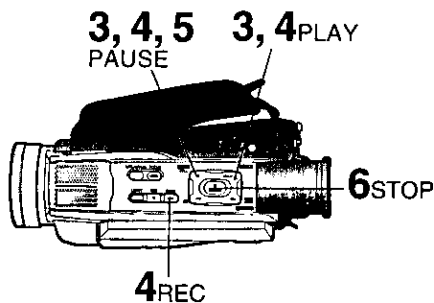
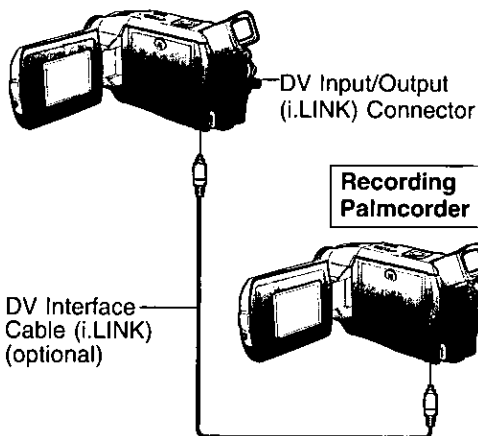

Before you begin

- Connect both Palmcoders to their power sources.
- Connect the two Palmcoders using the DV interface cable (i.LINK) (4-pin to 4-pin).
- Turn both Palmcoders ON.

- 1** Insert a pre-recorded tape into the source (playing) Palmcorder, and set **POWER** to **VCR**.
- 2** Insert a blank tape with the record tab closed into the target (recording) Palmcorder and set **POWER** to **VCR**.
- 3** Press **▶ (PLAY)** on the source Palmcorder. When the tape reaches the point you want to start dubbing, press **II (PAUSE)**.
- 4** Hold down **REC** and press **▶ (PLAY)** on the target (recording) Palmcorder. Press **II (PAUSE)** to pause the tape at the starting point of the dub.
- 5** Simultaneously, press **II (PAUSE)** on both units to begin dubbing.
- 6** Press **■ (STOP)** on the recording unit, and then press **■ (STOP)** on the playing unit to end dubbing.

Note

- When two Palmcoders are connected using the DV interface cable (i.LINK) (not supplied), a Video Editing Controller cannot be used.
- Do not connect both an A/V Cable and a DV Interface Cable (i.LINK).

CAUTION:

Unauthorized exchanging and/or copying of copyrighted recordings may be copyright infringement.

PC Connection with DV Interface Cable (i.LINK)

A video clip can be transferred directly to your PC (Personal Computer) via a DV Interface Cable (i.LINK) (not supplied) using products and software from a number of editing software companies including Canopus and Pinnacle.

Using products from these companies allows you to capture and edit video clips using the DV interface (i.LINK).

For more detailed information regarding editing software products from these companies, please visit their websites at:

www.justedit.com

www.pinnaclesys.com

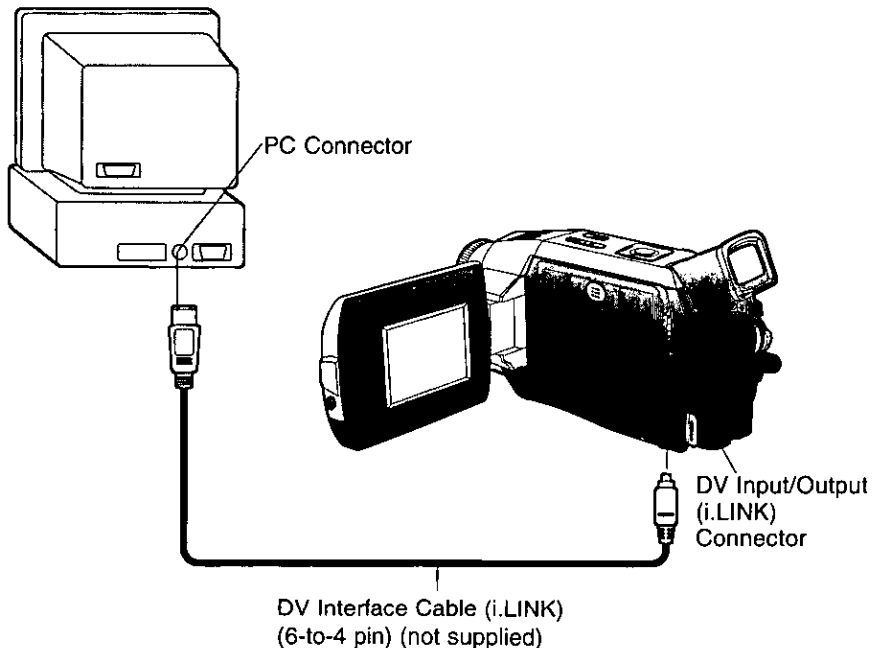

Note

- During Palmcorder playback, do not disconnect the DV Interface Cable (i.LINK) or turn the Palmcorder off as this may cause a PC hang-up error.

PHOTOVU LINK Driver (Optional)

An image recorded on the DV Tape can be transferred to your PC (Personal Computer).

System Requirements for PHOTOVU LINK Driver (Optional)

- IBM PC/AT or compatible
- Intel® Pentium® Processor
- Microsoft Windows 95/98/Me/2000/XP
- RAM: 16 MB or more
- 2 MB minimum available hard disk space
- 256 color monitor (full color recommended)
- 3.5 inch 1.44 MB floppy disk drive (for installation)
- RS-232C serial port (D-Sub 9-pin)
An adaptor (D-Sub 9-pin male to a D-Sub female) is required for a D-Sub 25-pin
- Mouse or other pointing device

*Satisfy the conditions recommended by Microsoft for Windows.

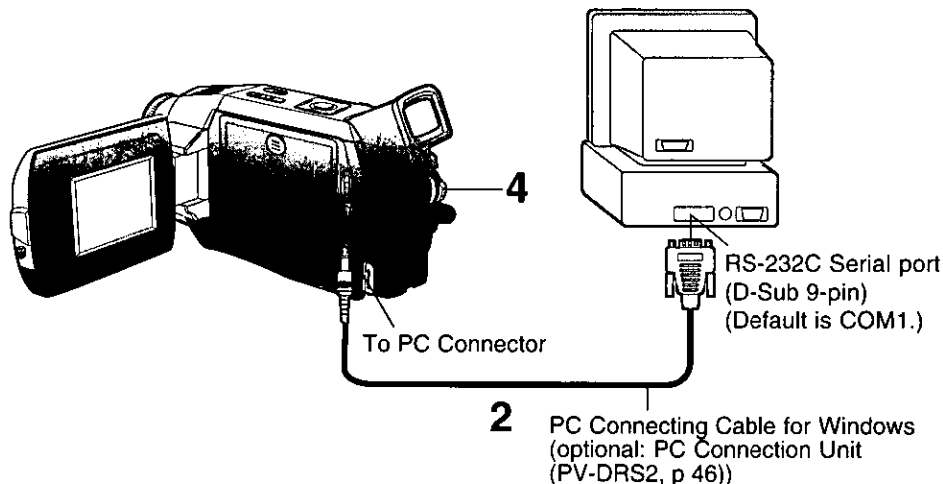
**Connection**

- 1** Turn off your PC.
- 2** Connect the Palmcorder to your PC (Windows) using the PC connecting cable (optional: PC Connection Unit (PV-DRS2, p 46)).
 - Before connecting the Palmcorder to the PC, make sure the PC power is off to insure that images are transferred properly.
- 3** Turn on your PC.
- 4** Set the Palmcorder POWER to VCR.

Note

- For extended periods of use, it is recommended to use the AC Adaptor as a power source.
- Refer to PC or Windows manual to identify which COM port is to be used for connection.

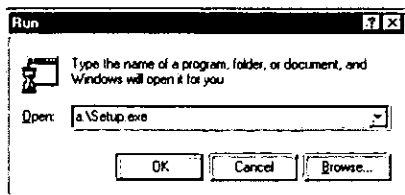

- 1 Turn your PC (Personal Computer) on and start up Windows.
- 2 Insert PHOTOVU LINK DRIVER Disk (Optional) into a floppy disk drive.
- 3 Click on Start, then "Run..."
- 4 Type in "a:\setup.exe" and click OK.
 - If your 3.5 inch floppy disk drive is not "A", use the appropriate letter.
- 5 Follow the instructions as they appear on the PC screen until the installation is complete.
 - Setup window will disappear when the installation is complete.

Running the Software

PHOTOVU LINK:

You can transfer images from your Palmcorder tape to your PC.

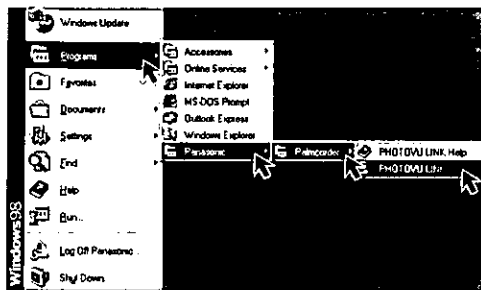

Before you begin

- Insert the Tape. (p. 9)
- Make Palmcorder-PC connections. (p. 43)
- Turn your PC on.
- Set Palmcorder POWER to VCR.

- 1 Click on Start, "Programs," "Panasonic," "Palmcorder," then "PHOTOVU LINK."
- 2 "PHOTOVU LINK" is opened.

Note

- COM Port and Baudrate are automatically selected.

Refer to Help for information about application operations and other Error messages.

Using Tape Image Data

Pictures captured with the Palmcorder can be transferred to your PC.

Before you begin

- Insert a recorded tape. (p. 9)
- Make Palmcorder-PC connections. (p. 43)
- Turn your PC on.
- Set Palmcorder POWER to VCR.

- 1 Repeat steps 1 and 2 on page 44 to run the Software.
- 2 "Preview Window" screen appears.
- 3 Search and Select a still scene you want to transfer to your PC using VCR Operation Buttons on the "Preview window" screen. Then click on "Transfer" to transfer selected image from camcorder to "Preview Window" in PLAY or STILL mode.

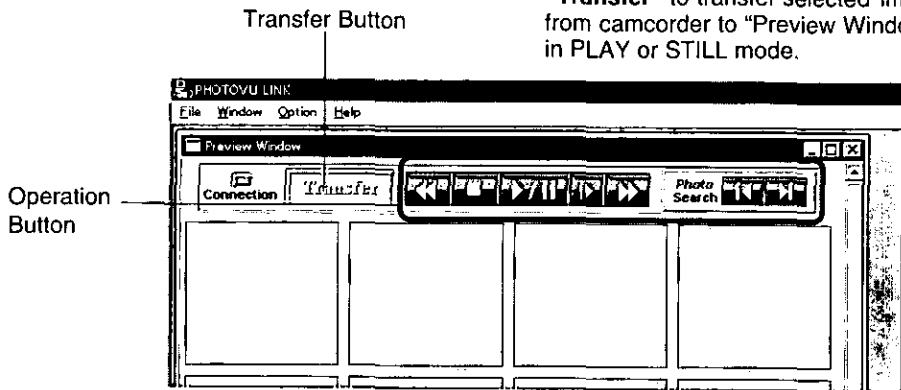



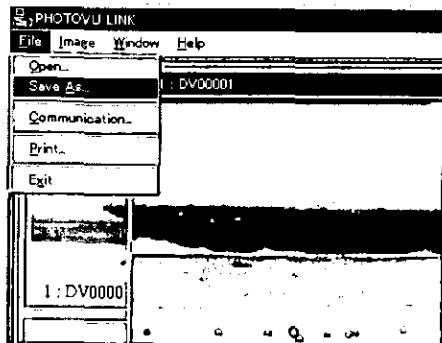

- 4 Click on "File" then "Save As". Save transferred image to PC.

Note

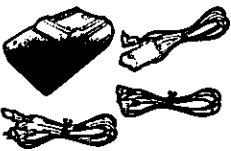
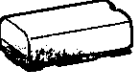
- If, while transferring the image to your PC, the displayed picture appears abnormal, close PHOTOVU LINK and turn Camcorder POWER off. Run PHOTOVU LINK again and turn Palmcorder Power back on. Now transfer again.
- Photo Search may fail to detect a recorded PhotoShot image if the image is 3 seconds or less.

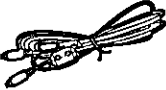
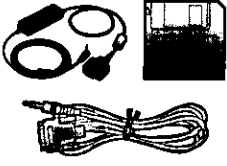

Accessory #	Figure	Description	Price
PV-DAC11A		AC Adaptor with AC Cable and DC Cable	Call for Pricing
CGR-D08A/1B		800mAh / 1 h 30 min, Battery Pack	\$69.95
CGR-D16A/1B		1600mAh / 3 h, Battery Pack	\$99.95
CGP-D28A/1B		2800mAh / 5 h, Battery Pack	\$129.95
CGR-D53A/1K		5300mAh / 9 h, Battery Pack	\$229.95
PV-DDC9		DV Interface Cable (i.LINK) (4-pin to 4-pin)	\$55.00
PV-DRS2		PC Connection Unit (RS-232C Serial Kit)	Call for Pricing

Palmcorder Accessory Order Form

Please photocopy this form when placing an order.

1. Palmcorder Model # _____

2. Items Ordered

Accessory #	Description	Price Each	Quantity	Total Price
Subtotal				
Your State & Local Sales Tax				
Shipping & Handling				6.95
Total Enclosed				

3. Method of payment (check one)

- Check of Money Order enclosed (NO C.O.D.SHIPMENTS)
- VISA Credit Card # _____
- MasterCard Expiration Date _____
- Discover Customer Signature _____

Make Check or Money Order to: PANASONIC ACCESSORIES

(Please do not send cash)

4. Shipping information (UPS delivery requires complete street address)

Ship To:

Mr.

Mrs.

Ms.

First

Last

Phone #:

Day () _____

Street Address

Night () _____

City

State

Zip

TO OBTAIN ANY OF OUR PALMCORDER ACCESSORIES YOU CAN DO ANY OF THE FOLLOWING:

VISIT YOUR LOCAL PANASONIC DEALER

OR

CALL PANASONIC'S ACCESSORY ORDER LINE AT 1-800-332-5368

[6 AM-5 PM M-F, 6 AM-10:30 AM SAT, PACIFIC TIME]

OR

MAIL THIS ORDER TO: PANASONIC SERVICES COMPANY ACCESSORY ORDER OFFICE

20421 84th Avenue South Kent, WA. 98032

Replacing the Bulb

- 1** Insert a rigid wire, such as an extended paper clip into point (A) and lift cover up.

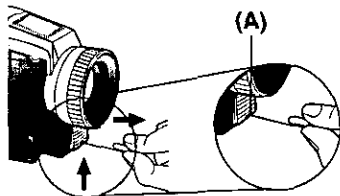

- 2** Using Tweezers or needle-nose pliers, carefully remove bulb.
- Take unit to servicenter if you need assistance.

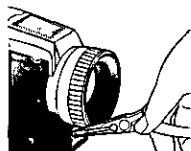

Before you begin

- Set POWER to OFF.

- 3** Replace bulb using a clean cloth or tissue. (Do not touch with fingers.)

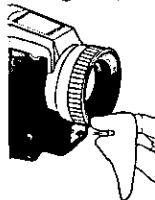

- 4** Replace lens cover.

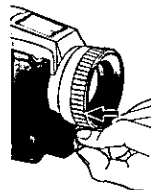

Note

- Handle bulb gently. Excessive force may cause bulb to crack.

DANGER:

Use only replacement bulb (PART NO. LSL0028) supplied by Panasonic to reduce risk of fire. Handle new bulb with cloth or tissue as skin oils decrease bulb life. Remove lens cover and allow bulb to cool before replacing to avoid possible burn hazard.

Notice

This product has a fluorescent lamp that contains a small amount of mercury. It also contains lead in some components. Disposal of these materials may be regulated in your community due to environmental considerations. For disposal or recycling information please contact your local authorities, or the Electronics Industries Alliance: <<http://www.eiae.org>.>

Approximate Brightness Values

Your Palmcorder has been designed for normal scene illumination of 150 footcandles (1500 lx). However, the Palmcorder may be used at F1:1.8, if illumination is more than 0.5 footcandles (5 lx).

The table below shows the color temperature for reference.

PALMCORDER SETTINGS	NATURAL LIGHT CONDITIONS	KELVIN COLOR TEMPERATURE	ARTIFICIAL LIGHT SOURCE	COLOR TINT MIXTURE	
	<ul style="list-style-type: none"> Fair weather, blue sky 	10,000	<ul style="list-style-type: none"> Color television 	Bluish	
	<ul style="list-style-type: none"> Slightly cloudy sky 	8,000			
	<ul style="list-style-type: none"> Cloudy or rainy sky 	7,000	<ul style="list-style-type: none"> Fluorescent lamp (Daylight) Camera flash bulb 		
	<ul style="list-style-type: none"> Sunlight in clear weather at midday 	6,000			
	<ul style="list-style-type: none"> Average sunlight in clear weather 	5,500			
	<ul style="list-style-type: none"> Sunlight 2 hours after sunrise and before sunset 	5,000	<ul style="list-style-type: none"> Blue lamp for photography 		
		4,500		<ul style="list-style-type: none"> Fluorescent lamp (White) 	Whitish
		4,000		<ul style="list-style-type: none"> Normal flash bulb 	
		3,500		<ul style="list-style-type: none"> Fluorescent lamp (Off-white) 	
		3,200		<ul style="list-style-type: none"> Tungsten lamp for photography 	
		2,800		<ul style="list-style-type: none"> Halogen lamp Iodine lamp 	
		2,000		<ul style="list-style-type: none"> Tungsten lamp Acetylene lamp Kerosene lamp Candlelight 	Yellowish Reddish

Power Source:	Palmcorder: 7.2 V DC (Battery) 7.8 V DC (AC Adaptor) AC Adaptor: 110/120/220/240 V AC, 50/60 Hz Battery: Lithium-Ion Type DC 7.2 V
Power Consumption:	Palmcorder : 7.2 V/7.8 V DC 6.5 W (Max. 9.5 W) AC Adaptor : 18 W 1 W (when not in use.)
Digital Interface	i.LINK (IEEE1394)
Video Signal:	EIA Standard (525 lines, 60 fields) NTSC color signal
Video Recording System:	2 rotary heads. helical scanning system
Audio:	12 bit (32 kHz) 4 tracks 16 bit (48 kHz) 2 tracks
Pick-Up System and Device:	One integral color filter Charge Coupled Device (CCD)
Lens:	10:1 zoom lens, F1:1.8 with auto iris control Focal length: 3.6 mm - 36 mm Power zoom function Lens filter diameter: 43 mm
Viewfinder:	5.3 mm (0.21 inch) Liquid Crystal Electronic Viewfinder
LCD Monitor:	63.5 mm (2.5 inch) Liquid Crystal Display
Minimum Illumination Required:	5 lx (F1:1.8) 0.5 footcandles
Operating Temperature:	32 °F~104 °F (0 °C~40 °C)
Operating Humidity:	10 %~75 %
Weight:	Palmcorder: 0.58 kg 1.28 lbs. AC Adaptor: 0.16 kg 0.35 lbs.
Dimensions:	Palmcorder: 88.5 (W) x 74 (H) x 182 (D) mm 3-1/2 (W) x 2-7/8 (H) x 7-1/8 (D) inch AC Adaptor: 70 (W) x 45 (H) x 115 (D) mm 2-3/4 (W) x 1-3/4 (H) x 4-1/2 (D) inch

Weight and dimensions shown are approximate.
Designs and specifications are subject to change without notice.

Cleaning Care for Video Heads

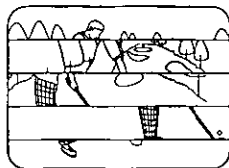

Clogged Video Head

(a) Video Head Cleaning: Normally, your Palmcorder will not require head cleaning. However, it is possible that the heads may become clogged due to dust in the air, playing damaged tapes, long term use, etc. If "NEED HEAD CLEANING" appears for 5 seconds in the EVF or LCD monitor, the heads may require cleaning.

(b) Cleaning the Heads: It is recommended that head cleaning be performed by a qualified service technician. Please contact your nearest Panasonic Servicenter. An alternate solution is to obtain a head cleaning cassette. Please use Panasonic cleaning cassette (AY-DVMCLA). Be sure to follow the cleaning instructions carefully. Excessive use of the head cleaning cassette could shorten video head life.

Use this cassette only when a head clogging symptoms occur.

Refer servicing to qualified service personnel.

Tape Operations Caution

- When you go from function to function (PLAY, FF, REW etc.), please note that the unit will not accept a new function operation until the previous operation is complete.
- The POWER Button and all function buttons, (PLAY, FF, REW, etc.) are only operational after the tape has been completely loaded.

Lens Hood Area Operation Caution

When the following accessories are attached and the zoom is set to maximum wide angle, the four corners of the screen may appear darker:

- Wide or Telephoto conversion lens (optional).
- A filter (optional), etc. and then the lens hood.
- Two filters (optional).

Before Requesting Service

If you have a problem with your Palmcorder, it may be something you can correct yourself. Check the list below for symptoms and corrections.

Symptom	Correction
No picture in the EVF or LCD Monitor...	<ul style="list-style-type: none">• Make sure the Power Source is connected. (pp. 11, 12)• Make sure the POWER switch is set to VCR or CAMERA. (pp. 15, 28)• Check the Dew Indicator. (p. 53)• Make sure the Battery is fully charged. (p. 11)• Make sure all necessary cables are connected correctly and firmly. (p. 12)• Make sure the Lens Cap is removed. (p. 15)
Video cassette cannot be inserted...	<ul style="list-style-type: none">• Make sure the Power Source is connected. (pp. 11, 12)• Insert the cassette record tab up, window side facing out. (p. 9)
Video cassette cannot be removed...	<ul style="list-style-type: none">• Make sure the Power source is connected. (pp. 11, 12)
No operation starts when operation buttons are pressed...	<ul style="list-style-type: none">• Check the Dew Indicator. (p. 53)
Recording cannot be done...	<ul style="list-style-type: none">• Make sure the record tab is closed. (p. 6)• Check the Battery Indication. (p. 63)
Auto Focus does not operate...	<ul style="list-style-type: none">• Make sure FOCUS is set to AUTO. (p. 25)• Make sure the unit is ON and set to CAMERA mode. (p. 15)
Sound from microphone cannot be monitored...	<ul style="list-style-type: none">• Make sure the unit is set to REC or REC/PAUSE mode.
Sound cannot be heard...	<ul style="list-style-type: none">• Make sure the Audio on the VCR MENU is set to ST1. (pp. 38, 61)

Request for Service Notice

Please photocopy this form when making a request for service notice.

Request for Service Notice:







In the unlikely event this product needs service.

- Please include your **proof of purchase**. (Failure to do so will delay your repair.)
- To further speed your repair, please provide an explanation of what is wrong with the unit and any symptom it is exhibiting.

Mail this completed form and your Proof of Purchase along with your unit to:

Panasonic Services Company
1705 N. Randall Road
Elgin, IL. 60123-7847
Attn: Camcorder Repair

The following warning displays appear in the EVF and the LCD monitor.

Indications	Condition
 TAPE NOT INSERTED	If the Palmcorder is in CAMERA mode without a cassette inserted, "RE" will flash and "TAPE NOT INSERTED" will appear for 5 seconds. Recording will not start.
 CHECK REC TAB	If the Palmcorder is in CAMERA mode or Audio dub mode with the cassette sliding record tab opened, "RE" will flash and "CHECK REC TAB" will appear for 5 seconds. Recording will not start.
 CANNOT REC	When Audio dub is performed and recording is other than NTSC format, "RE" will flash and "CANNOT REC" will appear for 5 seconds.
 TAPE END	When the tape is about to end in REC mode, "RE END" will flash and "TAPE END" will appear for 5 seconds.
INCOMPATIBLE TAPE	When an incompatible tape is detected, "INCOMPATIBLE TAPE" will appear for 5 seconds.
NEED HEAD CLEANING	If the video heads require cleaning, "NEED HEAD CLEANING" will appear for 5 seconds.
CANNOT REC LP-MODE	When an AUDIO DUB is attempted on a pre-recorded LP tape, "CANNOT REC LP-MODE" will appear for 5 seconds.
 DEW DETECTED	If excessive moisture condenses in the unit, "WARNING" will flash, "DEW DETECTED" will appear, and the Palmcorder will automatically turn OFF in 15 seconds. In this case, wait until the indicator no longer flashes when your Palmcorder is turned ON again.
  LOW BATTERY	When a battery recharge is necessary, "WARNING" will flash, "LOW BATTERY" will appear, and the Palmcorder will automatically turn OFF in 15 seconds. (p. 63)
CLOCK BATTERY	When the built-in lithium clock battery is discharged, "CLOCK BATTERY" will appear. To re-charge the lithium clock battery, connect the AC Adaptor to the Palmcorder. Recharging takes approx. 4 hours. Reset the clock after charging.
INCOMPATIBLE DATA	If you play a tape recorded in a format other than NTSC or you try to copy copy-protected data, "INCOMPATIBLE DATA" will appear.

For Your Information

Panasonic Consumer Electronics Company,
Division of Matsushita Electric Corporation
of America, One Panasonic Way
Secaucus, New Jersey 07094

Panasonic Sales Company,
Division of Matsushita Electric of Puerto Rico, Inc.
AVE. 65 de Infantería, Km. 9.5 San Gabriel
Industrial Park, Carolina, Puerto Rico 00985

PANASONIC/QUASAR Video Products Limited Warranty

Panasonic Consumer Electronics Company or Panasonic Sales Company (collectively referred to as "the Warrantor") will repair or replace this product with new or refurbished parts or equivalent product, free of charge, in the USA or Puerto Rico, in the event of a defect in materials or workmanship as follows (all time periods commence from the date of the original purchase):

PRODUCT	PARTS	LABOR	SERVICE	CONTACT NUMBER
CAMCORDER	ONE (1) YEAR, EXCEPT CCD IMAGE SENSOR CCD IMAGE SENSOR - SIX (6) MONTHS	NINETY (90) DAYS	Carry-In or Mail-In	1-800-211-PANA(7262)
		NINETY (90) DAYS		
DVD/VCR DECK	ONE (1) YEAR	NINETY (90) DAYS	Carry-In or Mail-In	1-800-211-PANA(7262)
DIGITAL STILL CAMERA	ONE (1) YEAR, EXCEPT CCD IMAGE SENSOR CCD IMAGE SENSOR - SIX (6) MONTHS	NINETY (90) DAYS	Carry-In or Mail-In	1-800-272-7033
		NINETY (90) DAYS		
A/V MIXER	ONE (1) YEAR	NINETY (90) DAYS	Carry-In or Mail-In	1-800-211-PANA(7262)
TV/VCR, TV/DVD TV/DVD/VCR COMBINATION	ONE (1) YEAR, EXCEPT CRT CRT - TWO (2) YEARS	NINETY (90) DAYS CRT - NINETY (90) DAYS	Carry-In: 21" CRT and Smaller	1-800-211-PANA(7262)
			In-Home or Carry-In: 22" CRT and Larger	
TV/HDR COMBINATION	ONE (1) YEAR, EXCEPT CRT CRT - TWO (2) YEARS	NINETY (90) DAYS CRT - NINETY (90) DAYS	In-Home or Carry-In	1-888-843-9788

Batteries (if included) - New rechargeable batteries in exchange for defective rechargeable batteries for ten (10) days. Non-rechargeable batteries are not warranted.

Tape (if included) - New video cassette tape in exchange for a defective video cassette tape for five (5) days.

Memory cards (if included) - Exchange defective item for new one for ninety (90) days.

In-home, carry-in or mail-in service, as applicable, in the USA can be obtained during the warranty period by contacting a Panasonic Services Company (PASC) Factory Servicenter listed in the Servicenter Directory. Or call toll free contact number listed above, to locate an authorized PASC Servicenter. Carry-in or mail-in service in Puerto Rico can be obtained during the warranty period by calling the Panasonic Sales Company telephone number listed in the Servicenter Directory.

This warranty is extended only to the original purchaser. A purchase receipt or other proof of the date of the original purchase is required before warranty service is rendered.

This warranty only covers failures due to defects in materials and workmanship, which occur during normal use and does not cover normal maintenance, including, but not limited to, video and audio head cleaning. The warranty does not cover damage which occurs in shipment, or failures which are caused by products not supplied by the warrantor, or failures which result from accident, misuse, abuse, neglect, mishandling, misapplication, alteration, modification, faulty installation, set-up adjustments, improper antenna, inadequate signal pickup, maladjustment of consumer controls, improper operation, power line surge, improper voltage supply, lightning damage, commercial use such as hotel, office, restaurant, or other business or rental use of the product, or service by anyone other than a PASC Factory Servicenter or a PASC authorized Servicenter, or damage that is attributable to acts of God.

LIMITS AND EXCLUSIONS

There are no express warranties except as listed above.

THE WARRANTOR SHALL NOT BE LIABLE FOR INCIDENTAL OR CONSEQUENTIAL DAMAGES (INCLUDING, WITHOUT LIMITATION, DAMAGE TO RECORDING MEDIA) RESULTING FROM THE USE OF THIS PRODUCTS, OR ARISING OUT OF ANY BREACH OF THE WARRANTY. ALL EXPRESS AND IMPLIED WARRANTIES, INCLUDING THE WARRANTIES OF MERCHANTABILITY AND FITNESS FOR PARTICULAR PURPOSE, ARE LIMITED TO THE APPLICABLE WARRANTY PERIOD SET FORTH ABOVE.

Some states do not allow the exclusion or limitation of incidental or consequential damages, or limitations on how long an implied warranty lasts, so the above exclusions or limitations may not apply to you.

This warranty gives you specific legal rights and you may also have other rights, which vary, from state to state. If a problem with this product develops during or after the warranty period, you may contact your dealer or Servicenter. If the problem is not handled to your satisfaction, then write to the Consumer Affairs Department at the Panasonic Consumer Electronics Company address above.

SERVICE CALLS WHICH DO NOT INVOLVE DEFECTIVE MATERIALS OR WORKMANSHIP AS DETERMINED BY THE WARRANTOR, IN ITS SOLE DISCRETION, ARE NOT COVERED.

COSTS OF SUCH SERVICE CALLS ARE THE RESPONSIBILITY OF THE PURCHASER.

warvid 02/ 12/ 2001

For Product Information, Operating Assistance, Literature Request, Dealer Locations, and all Customer Service inquiries please contact:
1-800-211-PANA (7262), Monday-Friday 9 am-9 pm; Saturday-Sunday 9 am-7 pm, EST.
or send e-mail to : consumerproducts@panasonic.com

Web Site: <http://www.panasonic.com>

You can purchase parts, accessories or locate your nearest servicer by visiting our Web Site.

Accessory Purchases:

1-800-332-5368 (Customer Orders Only)

Panasonic Services Company 20421 84th Avenue South, Kent, WA 98032

(6 am to 5 pm Monday - Friday; 6 am to 10:30 am Saturday; PST)

(Visa, MasterCard, Discover Card, American Express, Check)

Factory Servicenters Locations

CALIFORNIA

6550 Katella Avenue
Cypress, CA 90630

800 Dubuque Avenue
S. San Francisco,
CA 94080

3878 Ruffin Road
Suite A
San Diego, CA 92123

FLORIDA

3700 North 29th Avenue
Suite 102
Hollywood, FL 33020

GEORGIA

8655 Roswell Road
Suite 100
Atlanta, GA 30350

ILLINOIS

1709 North Randall Road
Elgin, IL 60123

MASSACHUSETTS

60 Glacier Drive
Suite G
Westwood, MA 02090

MINNESOTA

7850-12th Avenue South
Airport Business Center
Bloomington, MN 55425

OHIO

2236 Waycross Road
Civic Center Plaza
Forest Park, OH 45240

PENNSYLVANIA

2221 Cabot Blvd. West
Suite B
Langhorne, PA 19047

TEXAS

13615 Welch Road
Suite 101
Farmers Branch,
TX 75244

WASHINGTON

20425-84th Avenue
South
Kent, WA 98032

HAWAII

99-859 Iwaiwa Street
Aiea, Hawaii 96701
Phone (808) 488-1996
Fax (808) 486-4369

Service in Puerto Rico

Matsushita Electric of Puerto Rico, Inc. Panasonic Sales Company/ Factory Servicenter:
Ave. 65 de Infantería. Km. 9.5, San Gabriel Industrial Park, Carolina, Puerto Rico 00985
Phone (787) 750-4300 Fax (787) 768-2910

As of Sep. 2001

Precauciones para su seguridad

ADVERTENCIA: PARA EVITAR INCENDIOS Y DESCARGAS ELÉCTRICAS, NO EXPONGA ESTE EQUIPO A LA LLUVIA NI A LA HUMEDAD.

Su Mini **IX** Palmcorder está diseñada para grabar y reproducir en el modo de Reproducción Estándar (SP) y modo Largo (LP).

Se recomienda el uso sólo de cintas de cassette que hayan sido probadas e inspeccionadas para su uso en aparatos VCR con la marca Mini **IX**.

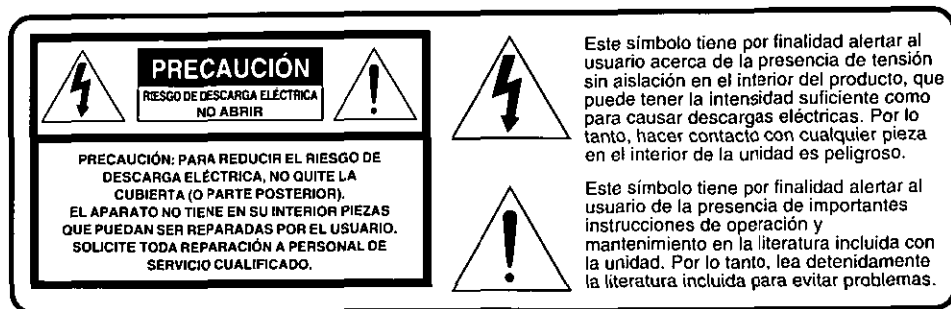

La etiqueta de régimen está pegada en la base de la cubierta del cargador.

Este dispositivo cumple con la parte 15 de las Reglas del FCC. El funcionamiento está sujeto a las dos siguientes condiciones: (1) Este dispositivo puede no causar interferencias perjudiciales, y (2) este dispositivo debe aceptar cualquier interferencia recibida, incluyendo interferencias que pueden causar un funcionamiento no deseado.

Nota: Este equipo ha sido puesto a prueba y se encontró que cumple con la Parte 15 de las reglas del FCC. Estos límites están diseñados para proveer una protección razonable contra interferencias cuando se opera en un ambiente residencial.

Si este equipo causa interferencias en la recepción de radio o televisión, lo cual se puede comprobar al apagar y encender el equipo, utilice el equipo en otra ubicación y/o utilice un tomacorriente diferente al que está utilizando el receptor. Si es necesario, consulte con el distribuidor o un técnico experto de radio/TV para solicitar ayuda. Puede encontrar útil el folleto 'Información sobre las interferencias' disponible en las oficinas regionales del FCC local.

Advertencia del FCC:

Para asegurar la conformidad continua del FCC, utilice solamente el cable de interfaz blindado cuando conecte una cámara de video digital a una computadora de acuerdo con las instrucciones incluidas aquí. También, cualquier cambio sin autorización o modificaciones a este equipo anularían la autoridad del usuario para operarlo.

Inserte de la batería

Antes de comenzar

- Cargue la batería. (Página 11.)

Film de protección

Nota

- Retire la película protectora antes de utilizarlo

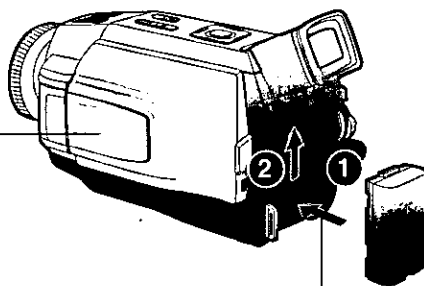

- 1 Coloque la batería y deslícela hacia arriba hasta que se quede bloqueada con un clic.

Inserte el Cassette

Esta videocámara contiene un sistema de ejecución fácil del cassette. Por eso, es fácil de introducir o sacar el cassette aunque esté montado sobre un trípode. (Página 7.)

- 1 Presione LCD-OPEN y abra completamente el monitor LCD.

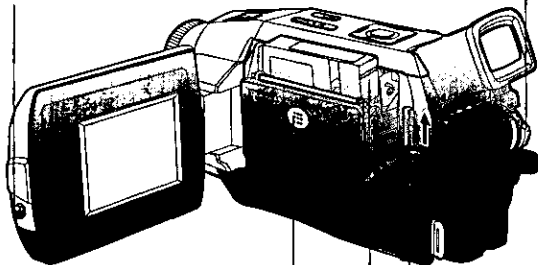

- 2 Ajuste el interruptor de alimentación (POWER) a la posición VCR o CAMERA.

- 3 Deslice el interruptor de expulsión de cinta (TAPE EJECT) para abrir la tapa del compartimento del cassette.

- 5 Presione la marca PUSH TO CLOSE (EMPUJAR PARA CERRAR) para cerrar la tapa del compartimento del cassette.

- 4 Introduzca un cassette con la parte de la ventana hacia arriba.
 - Asegúrese de que la lengüeta de grabación esté cerrada. (Página 6.)

Grabación con la cámara

Cuando el monitor LCD se encuentra totalmente abierto, el visor se DESACTIVA automáticamente.

- 1** Ajuste el interruptor de alimentación (POWER) a la posición CAMERA.

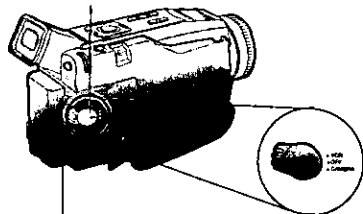

- 2** Ajuste el control de ajuste de visión según lo desee.

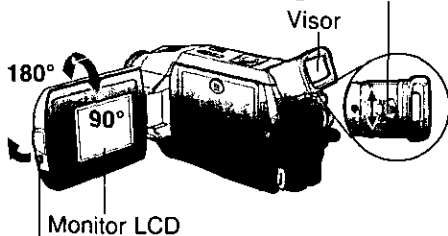

- 4** Presione el botón de grabación/pausa (REC/PAUSE) para iniciar la grabación. Vuelva a pulsar el botón de grabación/pausa (REC/PAUSE) para hacer una pausa en la grabación.

- 3** Presione el botón de apertura del LCD (LCD-OPEN) para desbloquear el monitor LCD. Balancee abriéndolo completamente y ajuste el ángulo.

Para ver la reproducción en el LCD (pantalla de visualización de cristal líquido)

Cuando el monitor LCD se encuentra totalmente abierto, el visor se DESACTIVA automáticamente.

Antes de comenzar

- Cargue la batería. (Página 11.)

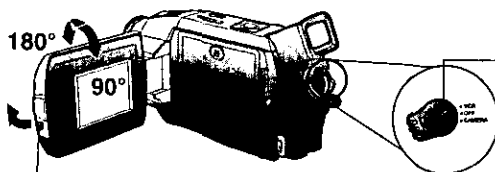

- 2** Presione el botón de apertura del LCD (LCD-OPEN) para desbloquear el monitor LCD. Balancee abriéndolo completamente y ajuste el ángulo.

- 3** Presione el botón de rebobinado (REW) para rebobinar la cinta.

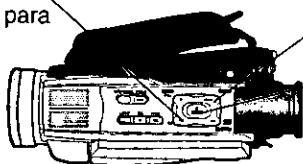

- 1** Ajuste el interruptor de alimentación (POWER) a la posición VCR.
- 4** Presione el botón de reproducción (PLAY) para reproducir la cinta.
- 5** Presione el botón de parada (STOP) para detener la reproducción.

Camera Mode Menu Screen

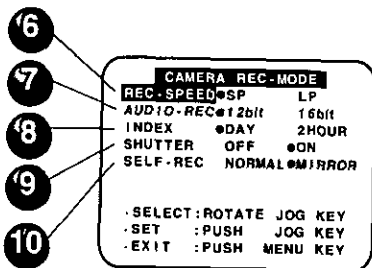
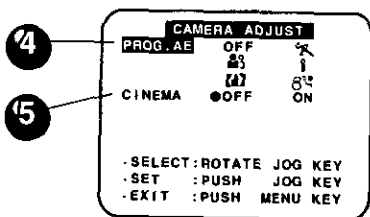
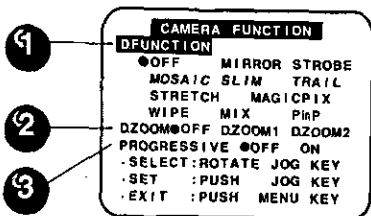

3 PROGRESSIVE (p. 17)
When set to ON, still pictures taken with PhotoShot are recorded with a higher resolution than with normal PhotoShot.

4 PROG. AE (p. 21)
To select one of the 5 Program AE modes. Setting to OFF cancels the previously selected Program AE mode.

5 CINEMA (p. 20)
When set to ON, you can record a picture compatible with a wide-screen TV equipped with an S2 picture terminal.

6 REC-SPEED (pp. 6, 15)
SP: Normal recording speed mode.
LP: Recording time is 1.5 times as long as in the SP mode. For example, 120 minutes of recording is possible on a 80 minute tape.

7 AUDIO-REC (p. 38)
12 bit: The sound is recorded in the 12 bit/32 kHz mode.
16 bit: The sound is recorded in the 16 bit/48 kHz high-quality mode.

8 INDEX DAY: An index signal is recorded when recording is restarted after the date has changed since the last recording.

2 HOUR: An index signal is recorded when recording is restarted after a lapse of more than 2 hours.

9 SHUTTER (p. 17)
When set to ON, still pictures taken in the PhotoShot mode are recorded with a visual shutter effect and click sound.

10 SELF-REC (p. 19)
NORMAL: During self-recording, the picture on the LCD Monitor is the same as it will be recorded.
MIRROR: During self-recording, the picture on the LCD Monitor is horizontally reversed.

1 D.FUNCTION (pp. 35, 37)
To select one of the 10 digital functions. Setting to OFF cancels the previously selected digital function.

2 D.ZOOM (p. 34)
To select D.ZOOM1 (from 10X to 25X) or D.ZOOM2 (from 10X to 700X). Setting to OFF cancels the previously selected digital zoom.

For Your Information

11

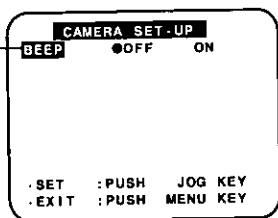

12

13

14

15

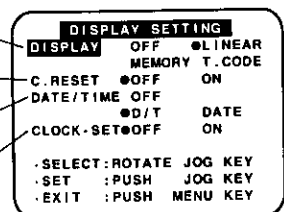

16

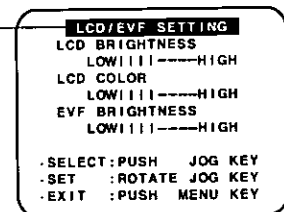

11

BEEP

Set to ON to hear beep when starting and stopping camera recording or when unusual conditions occur. To cancel the beep, set to OFF.

Palmcorder will beep:

Once when you start recording
Twice when you stop recording
Repeatedly when warning of unusual conditions.
(p. 53)

12

DISPLAY (p. 63)

To select the desired type of display and counter indication displayed on the LCD Monitor or in the viewfinder.

13

C.RESET (p. 63)

Setting to ON resets the counter to zero.

14

DATE/TIME (p. 64)

The date and time can be set and displayed on the screen.

15

CLOCK-SET (p. 13)

When set to ON, the date and time can be set on the screen.

16

LCD/EVF SETTING (p. 16)

Setting to ON displays the menu for adjusting the LCD brightness, color level, and the EVF brightness.

VCR Mode Menu Screen

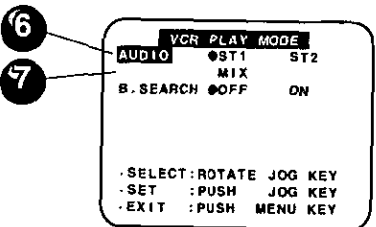
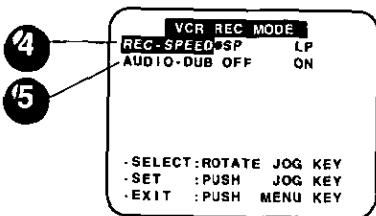
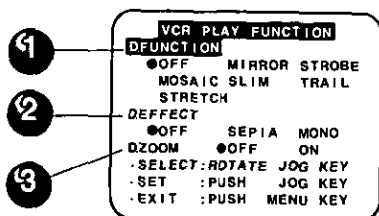

- ① **D.FUNCTION** (p. 37)
To select one of the 6 digital functions. Setting to OFF cancels the previously selected digital function.
- ② **D.EFFECT** (p. 37)
To select one of the 2 digital picture effects for playback. Setting to OFF cancels the previously selected digital effect.
- ③ **D.ZOOM** (p. 35)
Set to ON to double the size of a playback image. Setting to OFF cancels the previously selected digital zoom.
- ④ **REC-SPEED** (p. 6)
SP: Normal recording speed mode.
LP: Recording time is 1.5 times as long as in the SP mode. For example, 120 minutes of recording is possible on an 80 minute tape.
- ⑤ **AUDIO-DUB** (p. 38)
Set to AUDIO-DUB "ON" in the Menu OSD to use the Audio Dub feature.
- ⑥ **AUDIO** (p. 39)
To select the desired audio playback mode after performing audio dubbing in the 12 bit mode (SP mode only).
ST1 : The original sound alone is played back.
ST2 : The dubbed sound alone is played back.
MIX : The original sound and the dubbed sound are played back together.
- ⑦ **B.SEARCH (Blank Search)** (p. 29)
Select ON to go directly to a blank portion of the tape.

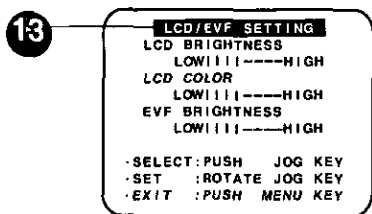
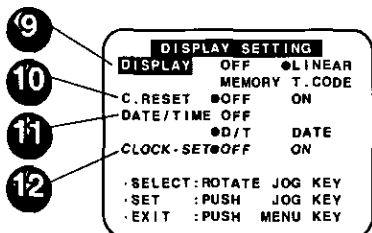
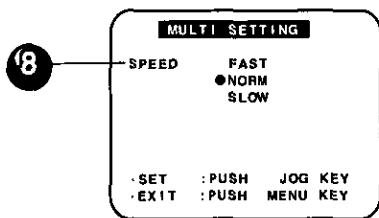

8 **SPEED** (p. 32)

In Strobe Multi mode, used to select the interval at which a succession of still screens are captured from the playback picture.

FAST : Every 0.3 seconds

NORM : Every 0.6 seconds

SLOW : Every 1.0 seconds

9 **DISPLAY** (p. 63)

To select the desired type of display and counter indication displayed on the LCD Monitor or in the viewfinder.

10 **C.RESET** (p. 63)

Setting to ON resets the counter to zero.

11 **DATE/TIME** (p. 64)

The date and time can be set and displayed on the screen.

12 **CLOCK-SET** (p. 13)

When set to ON, the date and time can be set on the screen.

13 **LCD/EVF SETTING** (p. 16)

Setting to ON displays the menu for adjusting the LCD brightness, color level, and the EVF brightness.

Here are some of the basic indications which will appear on the Palmcorder EVF and LCD Monitor. Only Date and Time indications will be recorded onto the tape.

CAMERA/VCR Mode

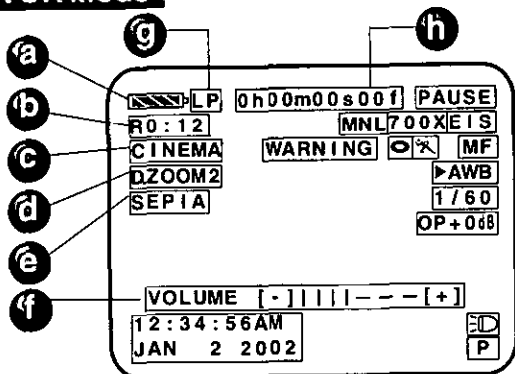

a Battery Remaining

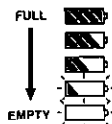

b Tape Remaining

(AY-DVM30EA) (AY-DVM60EA)



- It will take several seconds for the tape remaining indicator to operate after the tape starts moving.

c CINEMA Indication

(Menu OSD: p. 59)

d Digital Zoom and other Digital Functions

(Menu OSD: p. 59)
This display appears when the digital zoom function has been activated.

e Playback Effect

(Menu OSD: p. 61)
This display appears when SEPIA or MONO is selected in VCR menu.

f Volume Display

(p. 29)
The volume bar appears when the volume of the built-in speaker is being adjusted.

g Tape Speed Indication

(Menu OSD: p. 59)
Indicates the tape speed (SP or LP).

h Display ON/OFF and Counter/Time Code

The indication switches as shown below when the desired "DISPLAY" mode is selected from the menu. (Menu OSD: pp. 60, 62)

- When OFF is selected, all displays are turned off.

Linear Time Counter

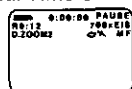

Memory Counter

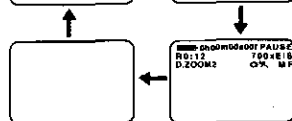
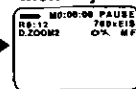

Time Code

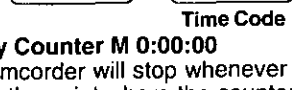

Memory Counter M 0:00:00

The Palmcorder will stop whenever it reaches the point where the counter was previously set to M 0:00:00 during audio dub, fast forward, or rewind.

Time Code 0h00m00s00f

The Palmcorder calculates and displays exactly where you are on any tape in terms of hours, minutes, seconds, and frames (30 frames = 1 second).

- This display cannot be reset.

IMPORTANT NOTE:

- Display must be set to ON for MF, AE, W.BALANCE or BACK LIGHT indications to be displayed on the EVF or LCD Panel when selected.
- C.RESET does not work when DISPLAY is set to OFF and T.CODE.

CAMERA/VCR Mode

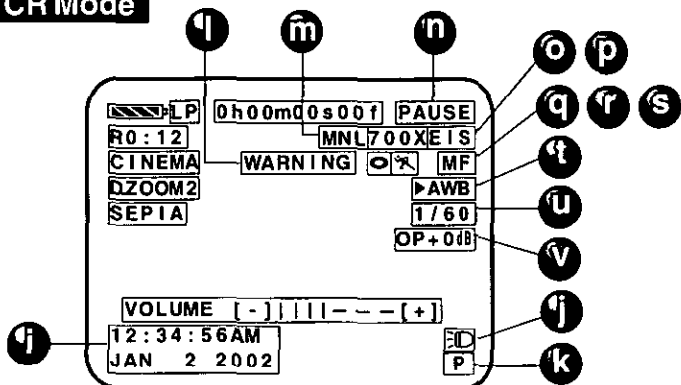

j Date and Time Indication (Menu OSD: pp. 60, 62)

As shown below, the date and time indication changes each time DATE/TIME is selected from the Palmcorder's MENU (Menu OSD: pp. 60, 62).

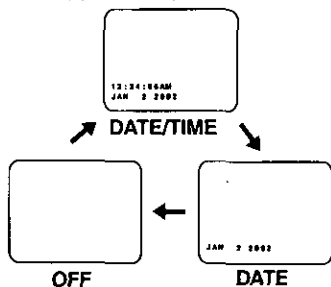

j Light Indication (p. 8) This display appears when LIGHT is set to ON.

k Progressive Indication (Menu OSD: p. 59) This display appears when PROGRESSIVE is set to ON.

l WARNING Indication (p. 53) The warning displays appear in the EVF and the LCD monitor.

m MNL Indication (pp. 24~27) This display appears when AUTO/MANUAL is pressed to MANUAL.

n Tape Mode Indications

- REC** Recording.
- PHOTO** PhotoShot recording.
- PAUSE** Paused during recording.
- >** Playback.
- ||** Still.
- >>** Slow (forward).
- <<** Slow (reverse).
- ||>** Frame Advance (forward).
- <||** Frame Advance (reverse).
- R>** Repeat Playback.
- CHK** Recording Check.
- FF** Fast forward.
- REW** Rewind.
- >>>** FF Search.
- <<<** REW Search.
- BLANK** Blank Search.
- SEARCH** Index Search.

o Zoom Magnification Level (p. 34)

p Digital EIS Indications (p. 36)

q Backlight Indication (p. 20)

r PROGRAM-AE Indication (p. 21)

s Manual Focus Indication (p. 25)

t White Balance Indication (p. 24)

u Shutter Mode Indication (p. 26)

v Iris Indication (p. 27)

Front View

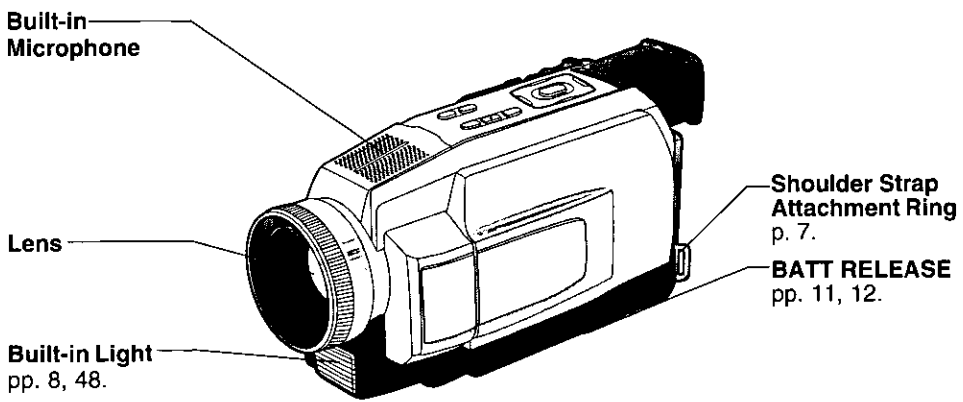

Side View

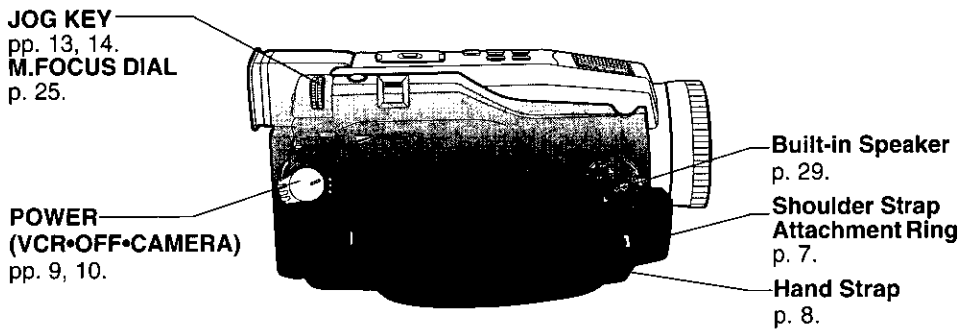

Rear View

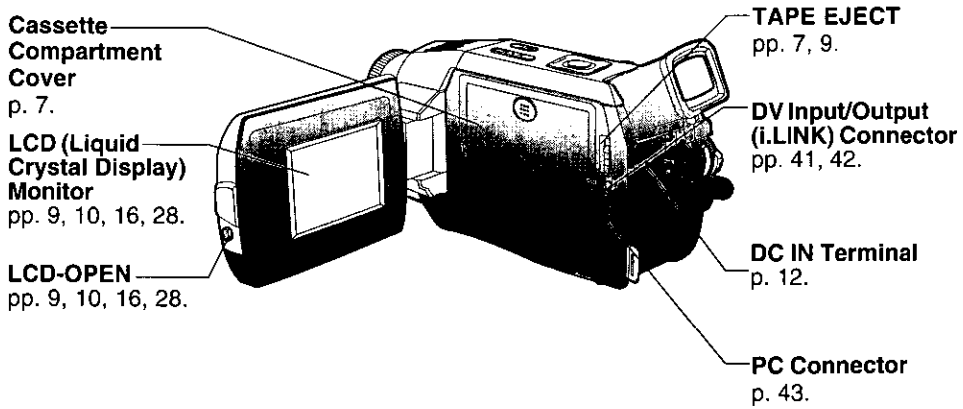

For Your Information

Rear View

Electronic Viewfinder (EVF)
p. 10.

MENU
pp. 13, 14.

A/V Output Connector
p. 33.

PHONE Jack
p. 28.

PHOTOSHOT
p. 17.

POWER ZOOM
pp. 18, 34.
VOLUME
p. 29.

Lens Cap
p. 8.

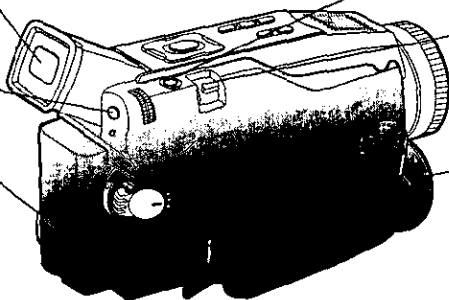

Top View

FOCUS
p. 25.

AUTO/MANUAL
pp. 24-27.

FADE
p. 22.
REC
p. 41.

LIGHT
p. 8.

EIS
p. 36.

REW
pp. 10, 28.
RECORDING CHECK
p. 18.

PAUSE
pp. 30, 39, 41.
CAMERA STILL
p. 23.

PLAY
pp. 10, 28.
MULTI
p. 32.

STOP
pp. 10, 28.

FF
p. 30.
BACK LIGHT
p. 20.

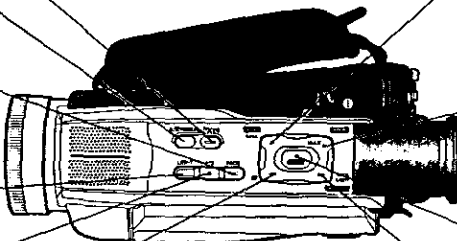

Back View

Vision Adjustment Control
pp. 10, 15.

POWER Lamp
p. 15.

REC/PAUSE
pp. 10, 15.

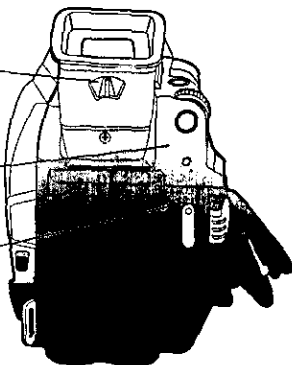

Underside View

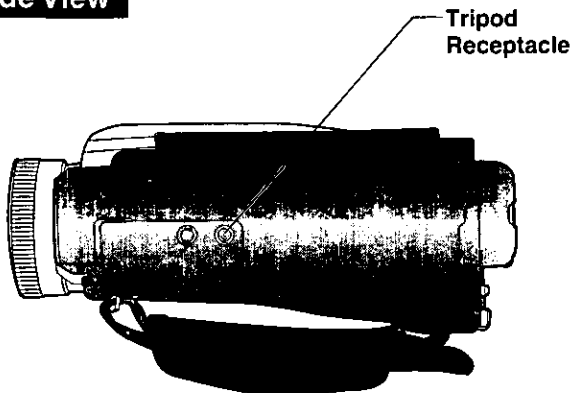

AC Adaptor

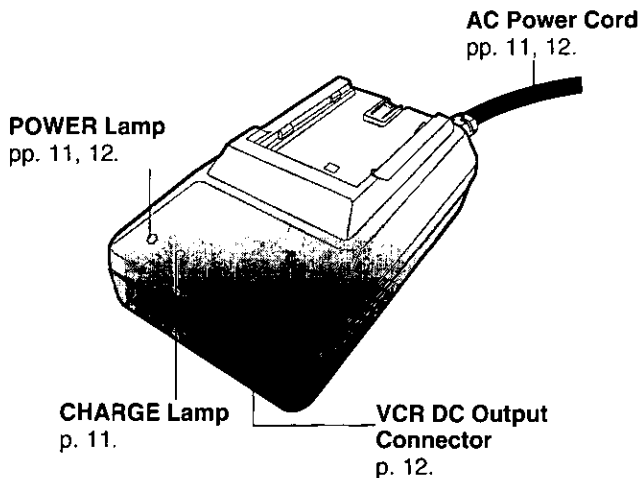

CAUTION:

This unit will operate on 110/120/220/240 V AC. An AC plug adaptor may be required for voltages other than 120V AC. Please contact either a local or foreign electrical parts distributor for assistance in selecting an alternate AC plug.

We recommend using the accessory power plug adaptor (VJSS0070) in an area which has special AC outlets.

- A**
 AC Adaptor ... 6, 11, 12, 46
 Accessories (Optional) . 46
 Accessories (Supplied) ... 6
 Adjusting the Volume 29
 A/V Cable 6, 33
 Audio Dubbing 38, 39
 Audio/Video Fade In/Out
 22
- B**
 Backlight 20
 Battery Pack ... 6, 9, 11, 46
 Battery Remaining
 Indication 63
 Battery Warning 53
 Before Requesting Service
 51, 52
 Blank Search 29
 Built-in Light 8
- C**
 CINEMA Mode 20
 Cleaning Care for
 Video Heads 51
 Clock Battery 53
 Clock Set 13
 Connecting Earphone ... 28
 Copying from Digital
 Equipment 41
 Copying your Tapes 40
- D**
 Date and Time Indication
 64
 DC Power Cable . 6, 12, 46
 DEW Indication 53
 Digital E.I.S. 36
 Digital Functions 37
 Digital PhotoShot™ Mode
 17
 Digital Video Cassette Tape
 6
 Digital Zoom 34, 35
 DV Interface Cable (i.LINK)
 41, 42, 46
- E**
 Easy Cassette Eject 7
 Erase Protection Tab 6
 EVF/LCD Monitor Indications
 63-64
- F**
 Fast Forward/Rewind Check .. 30
 Focus 25
- H**
 Hand Strap 8
 High Speed Shutter 26
- I**
 Important Safeguards 3
 Index of Controls 65-67
 Iris 27
- J**
 Jog Search 31
- L**
 LCD/EVF Setting 16
 Lens Cap 6, 8, 15
 Lens Cap Strap 6, 8
 Limited Warranty 54
- M**
 MagicPix™ Images 35
 Memory Counter 63
 MENU OSD 59-62
- O**
 On-Screen Display (OSD)
 53
- P**
 PC Connection 42, 43
 PHOTOVU LINK 44, 45
 Picture in Picture (PinP)
 23
 Playback using the LCD
 Monitor 28
 Precautions 4
 Program AE 21
 Progressive PhotoShot™
 Mode 17
- Q**
 Quick Guide 9, 10
- R**
 Rapid Visual Search 30
 Recording Check 18
 Recording Still Pictures ... 19
 Repeat Playback 29
 Replacing the Bulb 48
 Request for Service Notice
 52
- S**
 Safety Precautions 2
 Self Recording 19
 Servicenter List 55
 Set the Date and Time .. 13
 Shoulder Strap 6, 7
 Simple Recording ... 15, 16
 Spanish Quick Use Guide
 56-58
 Specifications 50
 STILL Picture 30
 Strobe Multi Mode 32
 Supplying Power 11, 12
- T**
 Table of Contents 5
 Tape Remaining Indications
 63
 Tape Speed 6
 Tape Warning 53
- U**
 Using the Palmcorder Menu
 14
- V**
 Variable Speed Search . 31
 VHF Connecting Cable
 40
 Volume Display 29, 63
- W**
 White Balance 24
- Z**
 Zoom In/Out 18

Panasonic Consumer Electronics Company,
Division of Matsushita Electric Corporation of America
 One Panasonic Way Secaucus, New Jersey 07094

Panasonic Sales Company ("PSC"),
Division of Matsushita Electric of Puerto Rico, Inc.
 Ave. 65 de Infantería, Km. 9.5 San Gabriel Industrial Park Carolina,
 Puerto Rico 00985



Printed in Japan
 LSQT0562A
 S0102A0