

ENGLISH

# Digital Video Camcorder

Mini DV Digital Video Cassette

SCD67/D70

**AF** Auto Focus

**CCD** Charge Coupled Device

**LCD** Liquid Crystal Display

## Owner's Instruction Book

Before operating the unit, please read this instruction book thoroughly, and retain it for future reference.

**US PATENT 4415844**

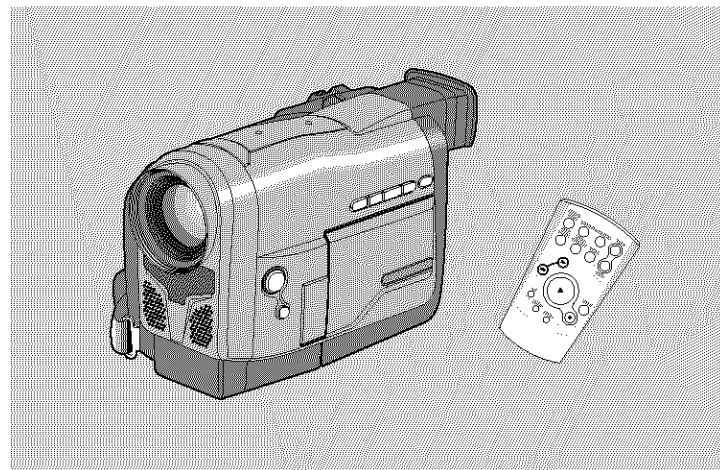



**SAMSUNG**  
ELECTRONICS

**ENGLISH**

# Notices and Safety Instructions

## Safety Instructions

	<b>CAUTION</b> RISK OF ELECTRIC SHOCK DO NOT OPEN	
CAUTION: TO REDUCE THE RISK OF ELECTRIC SHOCK, DO NOT REMOVE COVER (OR BACK). NO USER SERVICEABLE PARTS INSIDE. REFER SERVICING TO QUALIFIED SERVICE PERSONNEL.		

To prevent electric shock, match wide blade of plug to wide slot and fully insert.



This symbol is intended to alert the user to the presence of uninsulated dangerous voltage within the product's enclosure that may be of sufficient magnitude to constitute a risk of fire or electric shock.



This symbol is intended to alert the user to the presence of important operating and maintenance instructions in the literature accompanying this product.

### 1. READ INSTRUCTIONS:

All the safety and operating instructions should be read before the CAMCORDER is operated.

### 2. RETAIN INSTRUCTIONS:

The safety and operating instructions should be retained for future reference.

### 3. HEED WARNINGS:

All warnings on the CAMCORDER and in the operating instructions should be adhered to.

### 4. FOLLOW INSTRUCTIONS:

All operating and maintenance instructions should be followed.

### 5. CLEANING:

Unplug this CAMCORDER from the wall outlet before cleaning.  
Do not use liquid or aerosol cleaners.  
Use a dry cloth used for dusting cabinets.

### 6. ATTACHMENTS:

Do not use attachments not recommended by the CAMCORDER product manufacturer as they may be hazardous.

### 7. WATER AND MOISTURE:

Do not use this CAMCORDER near water; for example, near a bathtub, wash bowl, kitchen sink, laundry tub, in a wet basement, near a swimming pool or lake.

### 8. ACCESSORIES:

Do not place this CAMCORDER on an unstable cart, stand, tripod, bracket or table. The CAMCORDER may fall, causing serious injury to a child or adult, and serious damage to the unit. Use only with a cart, stand, tripod, bracket, or table recommended by the manufacturer or sold with the CAMCORDER. Any mounting of the unit should follow the manufacturer's instructions and should use a mounting accessory recommended by the manufacturer.

A. An appliance and cart combination should be moved with care.

Quick stops, excessive force and uneven surfaces may cause the appliance and cart combination to overturn.

PORTABLE CART WARNING  
(Symbol provided by RETAC)



# Notices and Safety Instructions

## 9. VENTILATION:

Slots and openings in the cabinet are provided for ventilation to ensure reliable operation of the CAMCORDER and to protect it from overheating. These openings must not be blocked or covered. Never place your CAMCORDER on a bed, sofa, rug, or other similar surface: on or near a radiator or heat register. This CAMCORDER should not be placed in a built-in installation such as a bookcase or rack unless proper ventilation is provided or the manufacturer's instructions have been adhered to.

## 10. POWER SOURCES:

The CAMCORDER should be operated only from the type of power source indicated on the label. If you are not sure of the type of power supply at your home, consult your appliance dealer or local power company. A CAMCORDER is intended to be operated from battery power, or other sources, refer to the operating instructions.

## 11. GROUNDING OR POLARIZATION:

This CAMCORDER may be equipped with either a polarized 2-wire AC line plug (a plug having one blade wider than the other) or a 3-wire grounding type plug, a plug having a third (grounding) pin. If you are unable to insert the plug fully into the outlet, try reversing the plug. If the plug still fails to fit, contact your electrician to replace your outlet. Do not defeat the safety purpose of the polarized plug.

## 12. POWER-CORD PROTECTION:

Power-supply cords should be routed so that they are not likely to be walked on or pinched by items placed upon or against them, paying particular attention to cords or plugs, convenient receptacles, and the point where they exit from the unit.

## 13. OUTDOOR ANTENNA GROUNDING:

If an outside antenna or cable system is connected to the CAMCORDER, be sure the antenna or cable system is grounded to provide some protection against voltage surges and built-up static charges, Section 810 of the National Electrical Code, ANSI/NFPA No. 70-1984, provides information with respect to proper grounding of the mast and supporting structure, grounding of the lead-in wire and supporting structure, grounding of the mast and supporting structure, grounding of the lead-in wire to an antenna discharge unit, size of grounding to conductors, location of antenna-discharge unit, connection to grounding electrodes and requirements for the grounding electrode. See figure below.

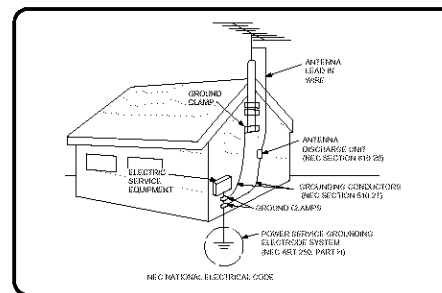

**ENGLISH**

## **Notices and Safety Instructions**

---

### **14. LIGHTNING:**

For added protection of this CAMCORDER during a lightning storm or when it is left unattended and unused for long periods of time, unplug it from the wall outlet and disconnect the antenna or cable system. This will prevent damage to the CAMCORDER due to lightning and power-line surges.

### **15. POWER LINES:**

An outside antenna system should not be located in the vicinity of overhead power lines or other electric light or power circuits where it can fall into such power lines or circuits. When installing an outside antenna system, extreme care should be taken to keep from touching such power lines or circuits as contact with them might be fatal.

### **16. OVERLOADING:**

Do not overload wall outlets and extension cords as this can result in a risk of fire or electric shock.

### **17. OBJECTS AND LIQUIDS:**

Never push objects of any kind into this CAMCORDER through openings as they may touch dangerous voltage points or short out a part that could result in a fire or electric shock.  
Never spill liquids of any kind onto the CAMCORDER. Should spillage occur, unplug unit and have it checked by a technician before use.

### **18. SERVICING:**

Do not attempt to service this CAMCORDER yourself. Opening or removing covers may expose you to dangerous voltage or other hazards.  
Refer all servicing to qualified service personnel.

### **19. DAMAGE REQUIRING SERVICE:**

Unplug this CAMCORDER from the wall outlet and refer servicing to qualified service personnel under the following conditions:

- When the power-supply cord or plug is damaged.
- If any liquid has been spilled onto, or objects have fallen into the CAMCORDER.
- If the CAMCORDER has been exposed to rain or water.
- If the CAMCORDER does not operate normally by following the operating instructions, adjust only those controls that are covered by the operating instructions. Improper adjustment of other controls may result in damage and will often require extensive work by a qualified technician to restore the CAMCORDER to its normal operation.
- If the CAMCORDER has been dropped or the cabinet has been damaged.
- When the CAMCORDER exhibits a distinct change in performance, this indicates a need for service.

### **20. REPLACEMENT PARTS:**

When replacement parts are required, be sure the service technician has used replacement parts specified by the manufacturer and having the same characteristics as the original part. Unauthorized substitutions may result in fire, electric shock or other hazards.

### **21. SAFETY CHECK:**

Upon completion of any service or repairs to this CAMCORDER, ask the service technician to perform safety checks to determine that the CAMCORDER is in safe operating order.

# Notices and Safety Instructions

---

**NOTE TO CATV SYSTEM INSTALLER:**

This reminder is provided to call the CATV system installer's attention to Article 820-40 of the NEC that provides guidelines for proper grounding and, in particular, specifies that the cable ground shall be connected to the grounding system of the building as close to the point of cable entry as practical.

**USER INSTALLER CAUTION:**

Your authority to operate this FCC certified equipment could be voided if you make changes or modifications not expressly approved by this party responsible for compliance to part 15 FCC rules.

# Contents

---

<b>Notices and Safety Instructions .....</b>	<b>4</b>
<b>Getting to Know Your Camcorder</b>	
Features	9
Accessories Supplied with your camcorder	10
Descriptions	
FRONT & LEFT VIEW	11
LEFT SIDE VIEW	12
RIGHT & TOP VIEW	13
REAR & BOTTOM VIEW	14
REMOTE CONTROL	15
OSD (On Screen Display)	16
How to use the Remote Control	18
<b>Preparing</b>	
Lithium Battery installation	19
Adjusting the Hand Strap and Shoulder Strap	20
Connecting a Power Source	21
Using the Lithium Ion Battery Pack	22
Inserting and Ejecting a Cassette	25
<b>Basic Recording</b>	
Making your First Recording	26
Hints for Stable Image Recording	28
Adjusting the LCD	29
Using the VIEWFINDER	29
Playing back a recording on the LCD	30
Controlling Sound from the Speaker	31
<b>Advanced Recording</b>	
Using the various Functions	
Setting the menu item	32
Availability of functions in each mode	33
LCD ADJUST	34
CUSTOM SET	34
DIS	35
PIP	36
Zooming In and Out with DIGITAL ZOOM	37
PROGRAM AE	39

# Contents

---

DSE (Digital Special Effects)	40
WHITE BALANCE	42
SHUTTER	43
IRIS	44
REC MODE	45
REC LAMP	46
WIND CUT	46
AUDIO MODE	47
DISPLAY	48
DATE TIME	49
DEMO	50
CLOCK SET	51
Easy mode	52
Custom mode	53
MF AF (Manual Focus Auto Focus)	54
BLC	55
Fade In and Out	56
Audio dubbing	57
PHOTO	58
Lighting Techniques	60
Various Recording Techniques	61
<b><i>Playing back a Tape</i></b>	
To watch with the LCD	62
To watch with a TV monitor	62
Playback	63
Various Functions in PLAYER mode	64
<b><i>IEEE 1394 Data Transfer</i></b> .....	<b>67</b>
<b><i>Maintenance</i></b>	
After finishing a recording	69
Cleaning and Maintaining the Camcorder	70
<b><i>Using Your Camcorder Abroad</i></b> .....	<b>71</b>
<b><i>Troubleshooting</i></b> .....	<b>72</b>
<b><i>Specifications</i></b> .....	<b>74</b>
<b><i>Index</i></b> .....	<b>76</b>
<b><i>Warranty</i></b> .....	<b>77</b>

# Notices and Safety Instructions

## *Notices regarding rotation of LCD screen*

Please rotate the LCD screen carefully as illustrated

Unintended rotation may cause damage to the inside of the hinge that connects the LCD screen to the Camcorder

1 LCD screen closed

2 Standard recording by using the LCD screen

3 Making a recording by looking at the LCD screen from the top

4 Making a recording by looking at the LCD screen from the front

5 Making a recording with the LCD screen closed

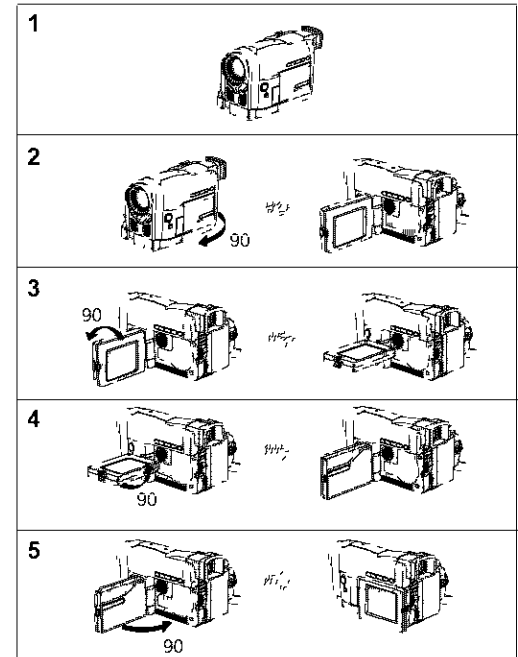



# Notices and Safety Instructions

---

## ***Notices regarding COPYRIGHT***

Television programs, video tapes, DVD titles, films, and other program materials may be copyrighted. Unauthorized copying of copyrighted material may be against the law.

## ***Notices regarding moisture condensation***

1. A sudden rise in atmospheric temperature may cause condensation to form inside the camcorder.

### **for example:**

- When you move the camcorder from cold outside to warm inside during the winter.
  - When you move the camcorder from cool inside to hot outside during the summer.
2. If the "DEW" protection feature is activated, leave the camcorder for at least two hours in a dry, warm room with the cassette compartment opened and the battery removed.

## ***Notices regarding CAMCORDER***

1. Do not leave the camcorder exposed to high temperature (above 60°C or 140°F). For example, in a parked car in the sun or under direct sunlight.
2. Do not let the camcorder get wet.  
Keep the camcorder away from rain, sea water, and any other form of moisture.  
If the camcorder gets wet, it may be damaged.  
Sometimes malfunction cannot be repaired.

ENGLISH

## Notices and Safety Instructions

### *Notices regarding the battery pack*

- Make sure that the battery pack is fully charged before recording outdoors.
- To preserve battery power, keep your camcorder turned off when you are not operating it.
- When your camcorder is in CAMERA mode, if it is left in STBY mode without operation for more than 5 minutes with a tape installed, it will automatically turn off to protect against unnecessary battery discharge.
- Make sure that the battery pack is fitted firmly into place.  
Dropping the battery pack may damage it.
- A brand new battery pack is not charged.  
Before using the battery pack, charge it completely.
- It is a good idea to use the viewfinder instead of the LCD when recording for a long time, because the LCD uses up more battery power.

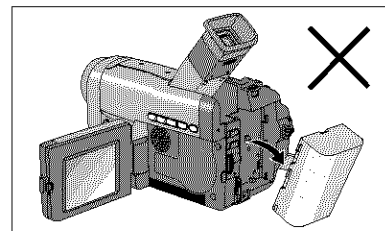

\*When the battery reaches the end of its life, please contact your local dealer.  
The batteries have to be dealt with as chemical waste.

### *Notices regarding video head cleaning*

- To ensure normal recording and a clear picture, clean the video heads regularly. If a square block-shaped noise distorts playback pictures, or if only a blue screen is displayed during playback, the video heads may be dirty. If this happens, clean the video heads with a dry type cleaning cassette.
- Do not use a wet type cleaning cassette. It may damage the video heads.

## Notices and Safety Instructions

### **Notice regarding the LENS**

- Do not film with the camera lens pointing directly at the sun.  
Direct sunlight can damage the CCD(Charge Coupled Device).

### **Notices regarding electronic viewfinder**

1. Do not position the camcorder such that the viewfinder is pointing towards the sun.  
Direct sunlight can damage the inside of the viewfinder.  
Be careful when placing the camcorder under sunlight or by a window.
2. Do not pick up the camcorder by the viewfinder.
3. Over-rotation of the viewfinder may damage it.

### **Notices regarding Record or Playback using LCD**

1. The LCD monitor is manufactured using high precision technology.  
However, there can be tiny dots(red, blue or green in color) that appear on the LCD monitor.  
These dots are normal and do not affect the recorded picture in any way.
2. When you use the LCD monitor in direct sunlight or outdoors, it may be difficult to see the picture.  
If this occurs, we recommend that the viewfinder is used.
3. Direct sunlight can damage the LCD monitor.

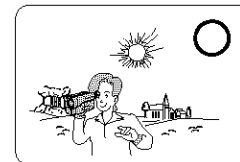
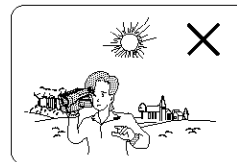

### **Notices regarding the hand strap**

- To ensure a steady picture during filming, check that the hand strap is properly adjusted.
- Do not force your hand into the hand strap as you could damage it.

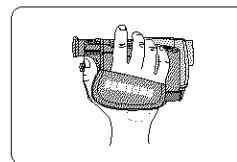

ENGLISH

## Notices and Safety Instructions

---

### *Precautions regarding the Lithium battery*

**Warning:** Keep the LITHIUM BATTERY out of the reach of children.

**Should any battery be swallowed, consult a doctor immediately.**

1. The lithium battery maintains the clock function and user settings; even if the battery pack or AC adapter is removed.
2. The lithium battery for the camcorder lasts about 6 months under normal operation from time of installation.
3. When the lithium battery becomes weak or dead, the date/time indicator will flash for about five seconds when you set the POWER switch to CAMERA. In this case, replace the lithium battery with a new one (type CR2025).

# Getting to Know Your Camcorder

---

## Features

- **Digital data transfer function with IEEE1394**  
By incorporating the IEEE 1394 (i.LINK™ : i.LINK is a serial data transfer protocol and interconnection system, used to transmit DV data) high speed data transport port, moving and still images can be transferred to your PC, making it possible to produce or edit various images.
- **PHOTO**  
The PHOTO function lets you capture an object as a still along with sound, while in Camera mode.
- **500x Digital zoom**  
Allows you to magnify an image to up to 500 times its original size.
- **Color TFT LCD**  
A high resolution color TFT LCD (with 112,320 pixels) gives you clean, sharp images as well as the ability to review your recordings immediately.
- **Digital Image Stabilizer**  
The DIS compensates for hand shake, reducing unstable images particularly at high magnification.
- **Various digital effects**  
The DSE (Digital Special Effects) allows you to give your recordings a special look by adding various special effects.
- **Back Light Compensation (BLC)**  
When you record a subject with the light source behind it or a subject with a light background, the BLC function compensates for the bright background.
- **Program AE**  
The Program AE enables you to alter the shutter speed and aperture to suit the type of scene/action to be recorded.

ENGLISH







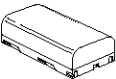

# Getting to Know Your Camcorder

## Accessories Supplied with your camcorder

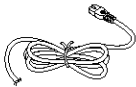
Make sure that the following basic accessories are supplied with your digital video camera.

### Basic Accessories

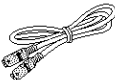
1. Lithium Ion Battery pack
2. AC Power Adapter
3. AC cord
4. AUDIO/VIDEO cable
5. Instruction Book
6. Shoulder Strap
7. Lithium batteries for Remote Control and Clock.  
(TYPE: CR2025, SCD67; 1 EA/SCD70; 2 EA)
8. S-VIDEO cable (SCD70 only)
9. Remote Control (SCD70 only)

1. Lithium Ion Battery pack  AD43-00070A	2. AC Power Adapter  AD44-00038A	3. AC cord  AD39-00028A
4. AUDIO/VIDEO cable  AD39-00001A	5. Instruction Book  Digital Video Camcorder	6. Shoulder Strap  AD63-00202B
7. Lithium batteries (2EA)-CR2025  AD43-10130H	8. S-VIDEO cable  AC39-42001Z	9. Remote Control  AD59-00066A

# Getting to Know Your Camcorder

## Front & Left View

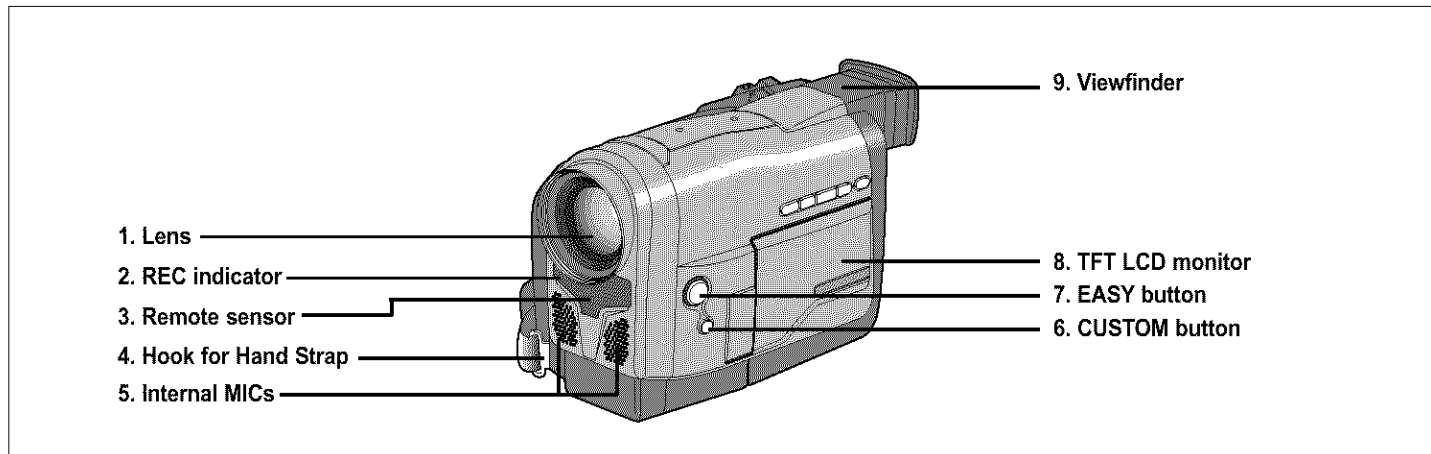

1. Lens
2. REC indicator
3. Remote sensor
4. Hook for Hand Strap (see page 20)
5. Internal MICs (Left and Right)
6. CUSTOM button (see page 53)
7. EASY button (see page 52)
8. TFT LCD monitor
9. Viewfinder (see page 29)

ENGLISH

# Getting to Know Your Camcorder

## Left Side View

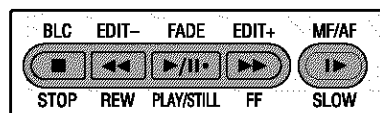

1. Function Buttons

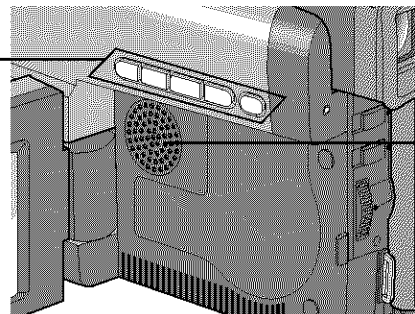

2. SPEAKER

### 1. Function Buttons

PLAYER : CAMERA

- (STOP) : BLC (see page 55)
- ◀◀ (REW) : EDIT -
- ▶▶/|| (PLAY/STILL) : FADE (see page 56)
- ▶▶ (FF) : EDIT +
- ▶ (SLOW) : MF/AF (see page 54)

### 2. SPEAKER



# Getting to Know Your Camcorder

## Right & Top View

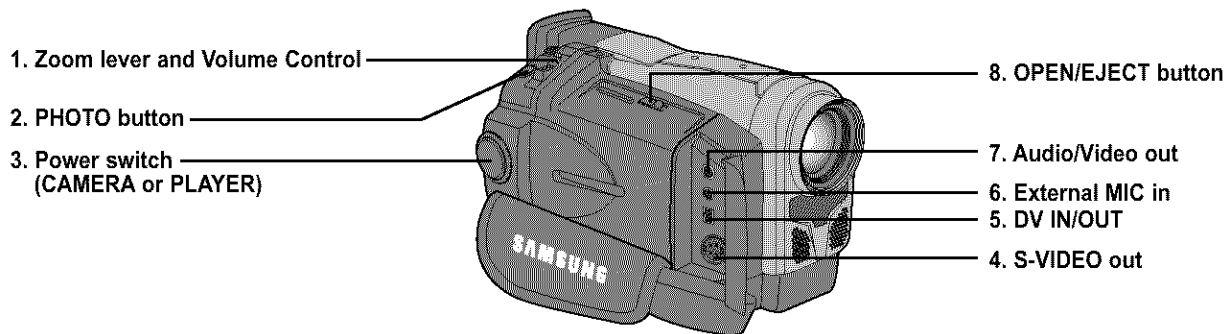

1. Zoom lever and Volume Control (see page 37)
2. PHOTO button (see page 58)
3. Power switch (CAMERA or PLAYER) (see page 21)
4. S-VIDEO out
5. DV IN/OUT
6. External MIC in (see page 57)
7. Audio/Video out
8. OPEN/EJECT button (see page 25)

# Getting to Know Your Camcorder

## Rear & Bottom View

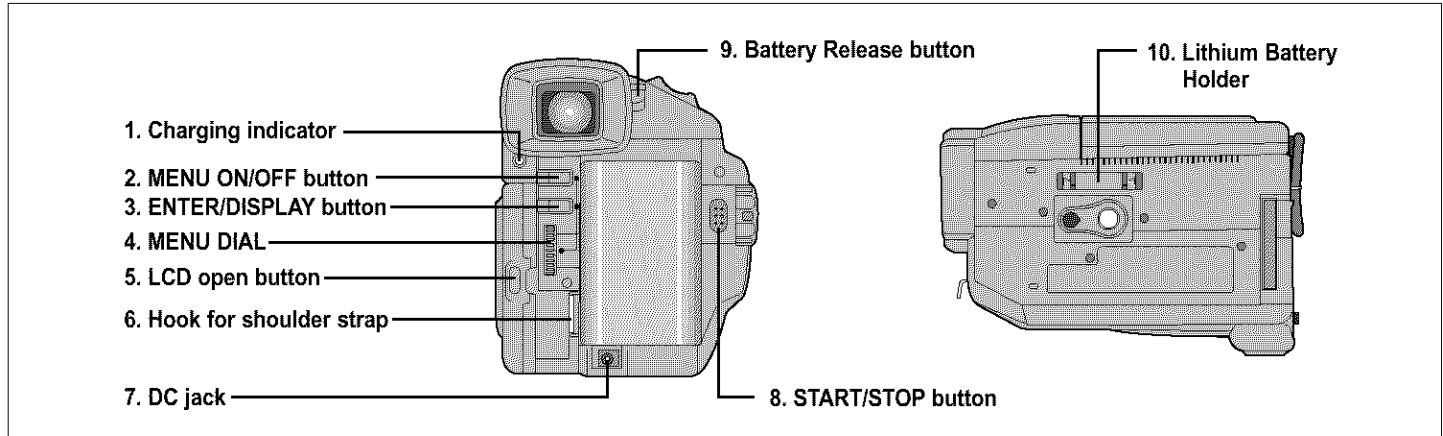

- 1. Charging indicator (see page 22)
- 2. MENU ON/OFF button (see page 32)
- 3. ENTER/DISPLAY button
- 4. MENU DIAL (see page 32)
- 5. LCD open button
- 6. Hook for shoulder strap
- 7. DC jack (see page 21)

- 8. START/STOP button (see page 26)
- 9. Battery Release button (see page 69)
- 10. Lithium Battery holder (see page 19)

# Getting to Know Your Camcorder

## Remote control (SCD70 only)

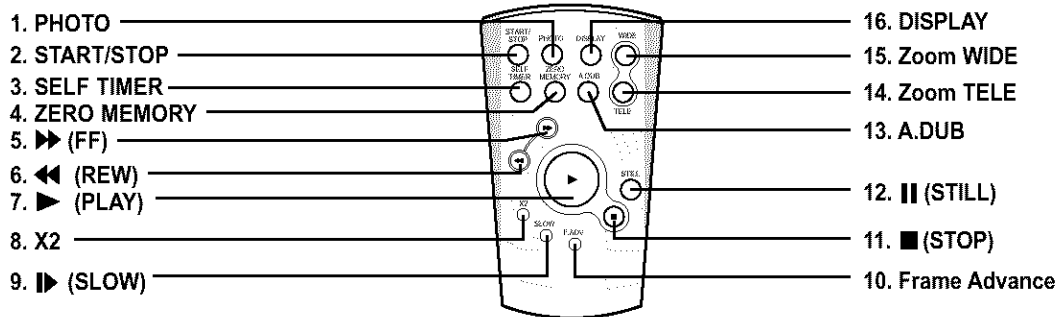

- 1. PHOTO
- 2. START/STOP
- 3. SELF TIMER (see page 18)
- 4. ZERO MEMORY (see page 66)
- 5. ►► (FF)
- 6. ◀◀ (REW)
- 7. ► (PLAY)
- 8. X2 (see page 65)
- 9. ◄► (SLOW)

- 10. Frame Advance (see page 65)
- 11. ■ (STOP)
- 12. || (STILL)
- 13. A.DUB (see page 57)
- 14. Zoom TELE
- 15. Zoom WIDE
- 16. DISPLAY (see page 17)

# Getting to Know Your Camcorder

## OSD (On Screen Display)

1. Battery level (see page 24)
2. Zoom position (see page 37)
3. Manual focus (see page 54)
4. DSE (Digital Special Effect) mode (see page 40)
5. White Balance mode (see page 42)
6. Shutter speed and IRIS (see page 43, 44)
7. Audio Record mode (see page 47)
8. Self record and waiting timer (see page 18) (SCD70 only)
9. WIND CUT (see page 46)
10. DATE/TIME (see page 49)
11. Self diagnosis (see page 72)
12. DEW condensation (see page 72)
13. PIP (Picture in Picture) (see page 36)
14. Photo shot (see page 58)
15. Digital zoom mode (see page 38)
16. Remaining Tape (measured in minutes)
17. Tape counter
18. Zero memory indicator (SCD70 only) (see page 66)
19. Operating mode
20. Record speed mode (see page 45)
21. Custom or Easy mode (see pages 52-53)
22. DIS (Digital Image Stabilizer) (see page 35)
23. Program AE (see page 39)
24. BLC (Back Light Compensation) (see page 55)

OSD in CAMERA mode

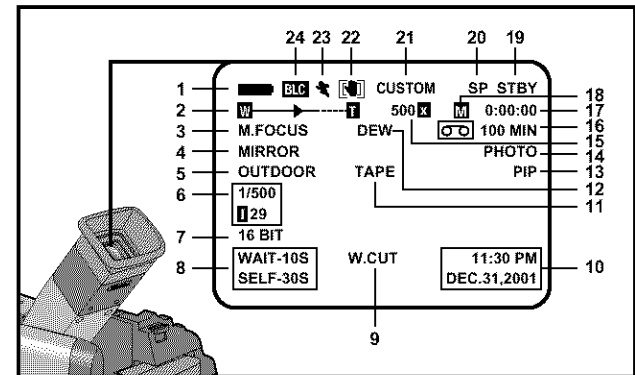

# Getting to Know Your Camcorder

## OSD (On Screen Display)

- 25. Volume control (see page 31)
- 26. Audio playback channel (see page 58)
- 27. Audio playback mode
- 28. DV IN (DV data receiving mode) (see page 67)
- 29. A.DUB (SCD70 only) (see page 57)

### OSD in PLAYER mode

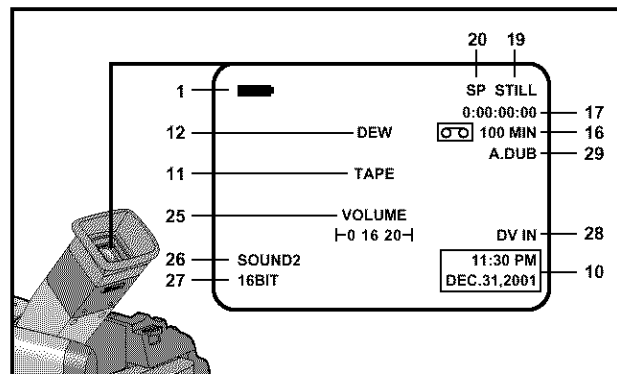

### Turning the OSD on/off (On Screen Display)

- ❖ When you set the power switch to CAMERA, the OSD is automatically turned on.
- ❖ When you set the power switch to PLAYER, the OSD is automatically turned off.
- ❖ Refer to page 48.
  - **Turning the OSD on/off**  
Press the ENTER button on the rear side panel.
    - Each press of the button toggles the OSD function on and off.
    - When you turn the OSD off,
      - In CAMERA mode: You can see those features being used.
      - In PLAYER mode: All OSD messages flash for 3 seconds then disappear.
  - **Turning on/off the DATE/TIME**
    - The DATE/TIME is not affected when the OSD function is switched ON or OFF.
    - To turn the DATE/TIME on or off, access the menu and change the DATE/TIME mode. (see page 49)

# Getting to Know Your Camcorder

## How to use the Remote Control (SCD70 only)

### Battery Installation for the Remote Control

- ❖ You must insert or replace the lithium battery when :
  - You purchase the camcorder.
  - The remote control doesn't work.
- ❖ Ensure that you insert the lithium cell correctly, following the + and - markings.
- ❖ Be careful not to reverse the polarity of the battery.

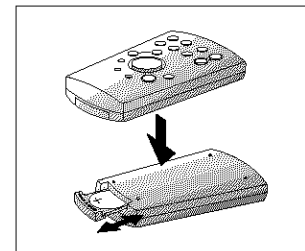
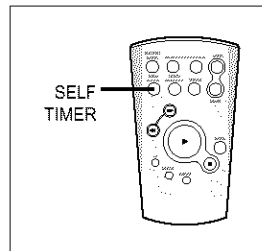

### Self Record using the Remote Control

The Self Timer function on the remote control enables you to start and stop recording automatically.

#### **Example: Scene with all members of your family**

Two options are available

- WAIT-10S/SELF-30S: 10 seconds wait, 30 seconds of recording.
- WAIT-10S/SELF-END: 10 seconds wait, records until you press the START/STOP button again.

1. Set the camcorder to CAMERA mode.
2. Press the SELF TIMER button until the appropriate indicator is displayed in the viewfinder :
  - WAIT-10S/SELF-30S
  - WAIT-10S/SELF-END
3. Press the START/STOP button to start the timer.
  - : After a 10 second wait, recording starts.
  - : If you have selected SELF-30S, recording stops automatically after 30 seconds.
  - : If you have selected SELF-END, press START/STOP again when you wish to stop recording.

# Preparing

## Lithium Battery Installation

- ❖ The lithium battery maintains the clock function and user settings; even if the battery pack or AC power adapter is removed.
- ❖ The lithium battery for the camcorder lasts about 6 months under normal operation from the time of installation.
- ❖ When the lithium battery becomes weak or dead, the date/time indicator flashes for about 5 seconds when you set the power switch to CAMERA. When this occurs, replace the lithium battery with type CR2025.

1. Remove the Lithium battery holder from the camera.
2. Position the Lithium cell in the holder, with the positive (⊕) terminal face down.
3. Reinsert the holder into the lithium battery compartment.

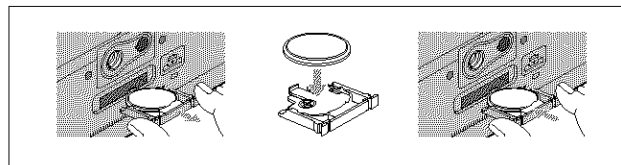
**Note**

The holder must be inserted in the correct direction or it will not fit properly.

**Warning:** Keep the LITHIUM BATTERY out of the reach of children.  
Should any battery be swallowed, consult a doctor immediately.

# Preparing

## Adjusting the Hand Strap and Shoulder Strap

It is very important to ensure that the Hand Strap is correctly adjusted before you begin your recording.

The hand strap enables you to :

- Hold the camcorder in a stable, comfortable position.
- Press the Zoom and START/STOP button without having to change the position of your hand.

### Hand strap

- a. Pull open the Hand-Strap cover and release the Hand Strap.
- b. Adjust its length and stick it back onto the hand strap cover.
- c. Close the Hand Strap cover back up again.

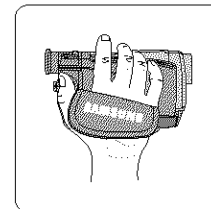
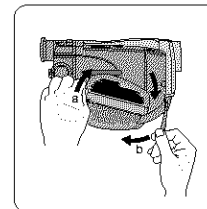

### Shoulder Strap

The Shoulder Strap enables you to carry your camcorder around in complete safety.

1. Insert the end of the strap into the Shoulder Strap hook on the camcorder.  
Insert the other end of the strap into the ring inside the hand strap.
2. Thread each end into the buckle, adjust the length of the strap and then pull it tight in the buckle.

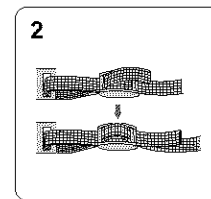
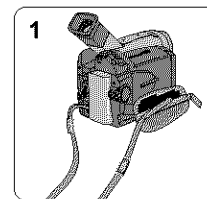



# Preparing

## Connecting a Power Source

There are two types of power source that can be connected to your camcorder.

- The AC Power Adapter and AC cord : used for indoor recording.
- The Battery Pack : used for outdoor recording.

### To use the AC Power Adapter and DC Cable

1. Connect the AC Power Adapter to the AC cord.

2. Connect the AC cord to a wall socket.

**Note**

The plug and wall socket type may be different depending on the country you're in.

3. Connect the DC cable to the DC jack socket on the camcorder.

4. Set the camcorder to the CAMERA or PLAYER mode by holding down the tab on the power switch and turning it to the CAMERA or PLAYER position.

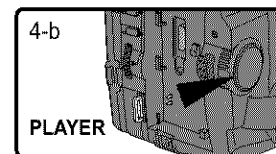
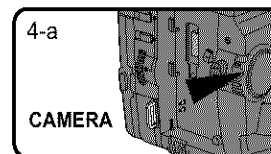
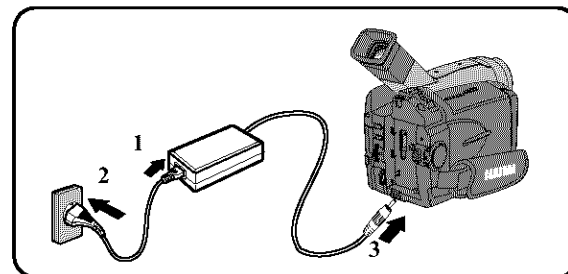

# Preparing

## Using the Lithium Ion Battery Pack

### To use the Lithium Ion Battery Pack

- ❖ The amount of continuous recording time available depends on :
  - The type and capacity of battery pack you are using.
  - How much you use the Zoom function.
 It is recommended that you have several available.

### Charging the Lithium Ion Battery Pack

1. Lift the viewfinder up and attach the battery pack to the camcorder.
2. Connect the AC Power Adapter to an AC cord and connect the AC cord to a wall socket.
3. Connect the DC cable to the DC jack socket on the camcorder.
4. Turn the camera POWER switch to off, the charging indicator will start to flash showing that the battery is charging.

Blinking time	Charging rate
Once in a second	Less than 50%
Twice in a second	50% ~ 75%
Three times in a second	75% ~ 99%
Stays on steady	Fully charged
On for a second and off for a second	Error - Reset the battery and DC cable.

5. When it has finished charging, disconnect the battery and AC Power Adapter from the camcorder.
  - Even with the power switched off, the battery will still discharge is left connected to the camcorder.

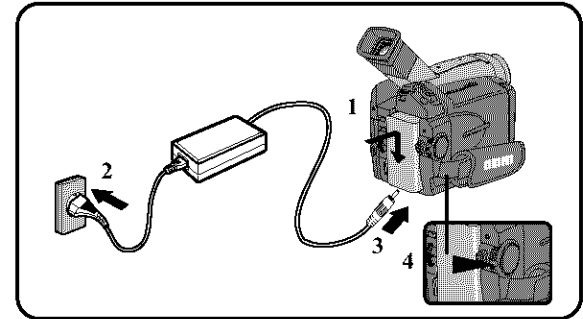

### Notes

- The battery pack may be charged a little at the time of purchase.
- To prevent reduction in the life and capacity of the battery pack, always remove it from the camcorder after it is fully charged.

# Preparing

## Using the Lithium Ion Battery Pack

Table of continuous recording time based on model and battery type.

Time Battery	Charging time	Continuous recording time	
		LCD ON	EVF ON
SB-L110	Approx. 2hr	Approx. 1hr 10min	Approx. 1hr 30min
SB-L220	Approx. 3hr 30min	Approx. 2hr 20min	Approx. 3hr

- ❖ If you close the LCD monitor, it switches off and the EVF is switches on automatically.
- ❖ The continuous recording times given in the table are approximate.  
Actual recording time depends on usage.

### Notes

- The battery pack should be recharged in an environment between 32°F (0°C) and 104°F (40°C).  
It should never be charged in a room temperature that is below 32°F (0°C).
- The life and capacity of the battery pack will be reduced if it is used in temperatures below 32°F (0°C) or left in temperatures above 104°F (40°C) for a long period, even when it is fully recharged.
- Do not put the battery pack near any heat source (fire or flames, for example).
- Do not disassemble, process, pressure, or heat the Battery Pack.
- Do not allow the + and – terminals of the battery pack to be short-circuited.  
It can cause leakage, heat generation, induction of fire and overheating.

# Preparing

## Battery level display

- The battery level display indicates the amount of power remaining in the battery pack.
  - a. Fully charged
  - b. 10% used
  - c. Half used
  - d. Mostly used
  - e. Completely used (flickers)  
(camcorder will turn off soon, change the battery as soon as possible)

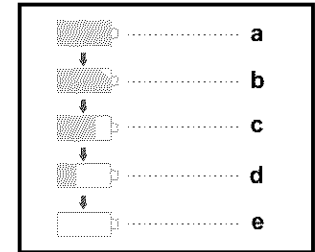

- ❖ Please refer to the table on page 23 for approximate continuous recording times.
- ❖ The recording time is affected by environmental temperature and conditions.

The recording time becomes very short in a cold environment. The continuous recording time in the operating instructions is measured using a fully charged battery pack at 77°F(25°C). As the environmental temperature and conditions may be different when you actually use the camcorder, the remaining battery time may not be the same as the approximate continuous recording times given in these instructions.

## Tips for Battery Identification

- ❖ A charge mark is provided on the battery pack to help you remember whether it has been charged or not. Two colors are provided (red and black)-you may choose which one indicates charged and which indicates discharged.
- ❖ The Charge mark does not affect the battery's charge status.

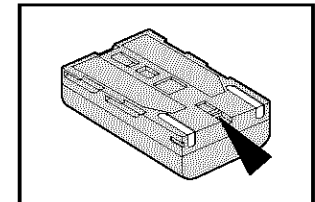

# Preparing

## Inserting and Ejecting a Cassette

- ❖ Use Mini DV Cassettes only.
- ❖ When inserting a tape or closing a cassette holder, do not apply excessive force. It can cause a malfunction.
- ❖ Do not use tapes other than Mini DV CASSETTE.

1. Connect a power source. Slide the OPEN/EJECT button forward and open the cassette door all the way.
  - The compartment opens automatically.
2. Insert a tape into the cassette holder with the tape window facing outward and the protection tab toward the top.
3. Press the area labelled PUSH on the cassette holding mechanism until it clicks into place.
  - The cassette is loaded automatically.
4. Close the cassette door.
  - The camcorder will not operate with the cassette door open.

### Note

When you have recorded something that you wish to keep, you can protect it so that it will not be accidentally erased.

#### a. Recording Impossible(Protection) :

Push the safety tab on the cassette so that the hole is not covered.

#### b. Recording possible :

If you no longer wish to keep the recording on the cassette, push the protection tab back so that it covers the hole.

#### • How to keep a tape

- a. Avoid places where there are magnets.
- b. Avoid humidity-and-dust prone places.
- c. Keep it in an vertical position and avoid storing in direct sunlight.
- d. Avoid dropping or knocking your tapes.

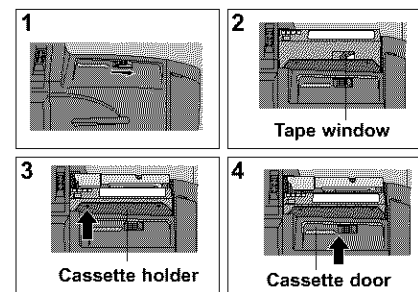

#### a. SAVE

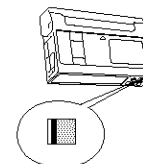

#### b. REC

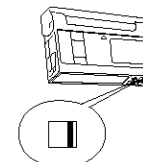

# Basic Recording

## Making your First Recording

1. Connect a Power source. (see page 21)  
(Battery pack or AC power adapter)
  - Insert a cassette. (see page 25)
2. Remove the LENS CAP and hook it onto the hand strap.
3. Set the power switch to the CAMERA position.
  - Open the LCD monitor and make sure that STBY is displayed.
  - If the protection tab of the cassette is open, STOP will be displayed.
  - Make sure the image you want to record appears in the LCD monitor or viewfinder.
  - Make sure the battery level indicates that there is enough remaining power for your expected recording time.
4. To start recording, press the START/STOP button.
  - REC is displayed in the LCD.

To stop recording, press the START/STOP button again.

  - STBY is displayed in the LCD.

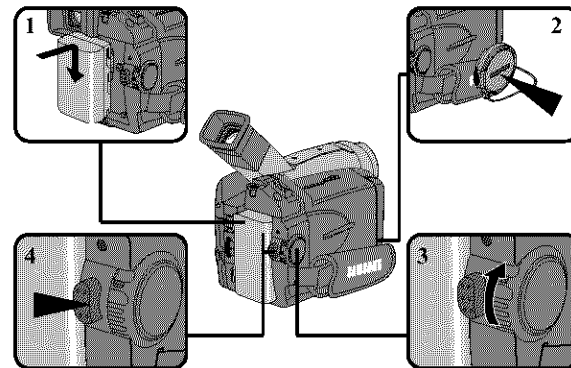

## Basic Recording

When a cassette is loaded and the camcorder is left in the STBY mode for more than 5 minutes without being used, it will switch off automatically. To use it again, push the START/STOP button or set the Power switch to OFF and then back to CAMERA.

This Auto Power off feature is designed to save battery power.

### Edit Search

- ❖ You can view a recording using with the EDIT +, - function in STBY mode.  
EDIT - enables you to play it backwards and EDIT + enables you to play it forwards, for as long as you keep pressing.

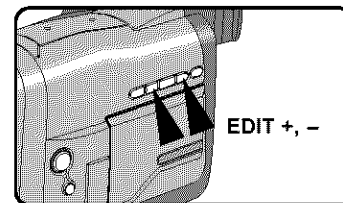

- ❖ If you press the the EDIT - button quickly in STBY mode, your camcorder will play in reverse for 3 seconds and return to the original position automatically.

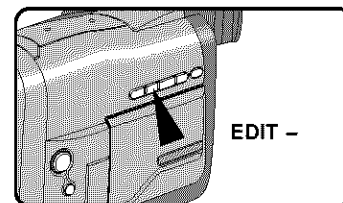
**Note**

- Mosaic shape noise may appear on the screen during edit search mode.

# Basic Recording

## *Hints for Stable Image Recording*

- While recording, it is very important to hold the camcorder correctly.
- Fix the LENS cap firmly by clipping it on the hand strap. (refer to figure)

### **Recording with the LCD monitor**

1. Hold the camcorder firmly using the hand strap.
2. Place your right elbow against your side.
3. Place your left hand under or beside the LCD to support and adjust it.  
Do not touch the built-in microphone.
4. Choose a comfortable, stable position for the shots that you are taking.  
You can lean against a wall or on a table for greater stability. Do not forget to breathe gently.
5. Use the LCD frame as a guide to determine the horizontal plane.
6. Whenever possible, use a tripod.

### **Recording with Viewfinder**

1. Hold the camcorder firmly using the hand strap.
2. Place your right elbow against your side.
3. Place your left hand under the camcorder to support it.  
Be sure not to touch the built-in microphone.
4. Choose a comfortable, stable position for the shots that you are taking.  
You can lean against a wall or on a table for greater stability. Do not forget to breathe gently.
5. Place your eye firmly against the viewfinder eyecup.
6. Use the viewfinder frame as a guide to determine the horizontal plane.
7. Whenever possible, use a tripod.

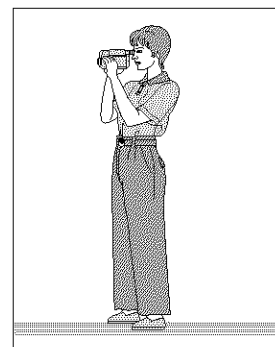
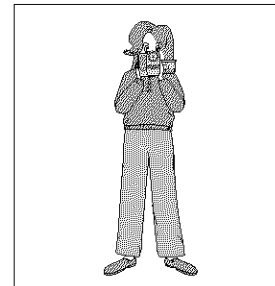
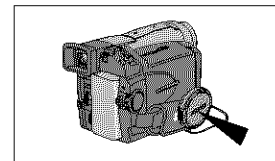



# Basic Recording

## Adjusting the LCD

- ❖ Your camcorder is equipped with a 2.5 inch color Liquid Crystal Display(LCD) screen, which enables you to view what you are recording or playing back directly.
  - ❖ Depending on the conditions in which you are using the camcorder (indoors or outdoors for example), you can adjust ;
    - Brightness
    - Color
1. Set the POWER switch to CAMERA or PLAYER position.
  2. Open the LCD monitor, the LCD switches on.
  3. Press the MENU ON/OFF button.
  4. Turn the MENU DIAL so that LCD ADJUST is highlighted.
  5. Press ENTER to enter the sub-menu.
  6. Turn MENU DIAL so that it highlights the menu item you want to adjust (BRIGHT, COLOR).
  7. Press ENTER again.
    - You can adjust the LCD using MENU DIAL.
  8. Press ENTER.
    - For further adjustment, repeat steps 6, 7, 8.
  9. Press the MENU ON/OFF button to finish the setting.

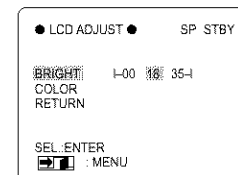
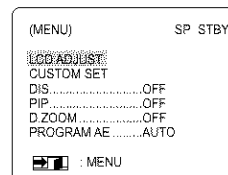
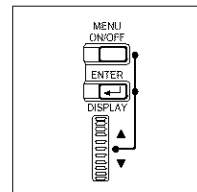

## Using the VIEWFINDER

### Adjusting the Focus

Use the focus adjustment knob of the VIEWFINDER to focus the picture. (refer to figure)

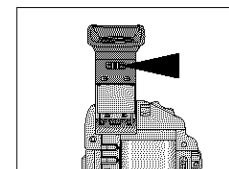

ENGLISH

## Basic Recording

### *Playing back a recording on the LCD*

- ❖ You can view the playback picture on the LCD monitor.
  - ❖ Make sure that the battery pack is in place.
1. Hold down the tab of the Power switch and turn it to the PLAYER position.
  2. Insert the tape you want to view.
  3. Open the LCD monitor and make sure that STOP is displayed.  
Adjust the angle of the LCD monitor and set the brightness or the color if necessary.
  4. Press the ◀◀ (REW) button to rewind the tape to the start point.
    - To stop REWIND, press the ■ (STOP) button.
    - Camcorder stops automatically after rewinding.
  5. Press the ▶▶ (PLAY/STILL) button to start playback.
    - You can see the picture you recorded on the LCD.
    - To stop the PLAY operation, press the ■ (STOP) button.

#### Notes

- You can also view the picture on a TV screen, after connecting the camcorder to a TV or VCR. (see page 62)
- Various functions are available in playback mode. (see page 64)

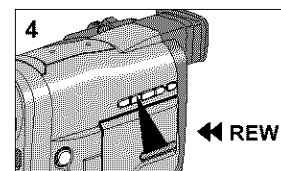
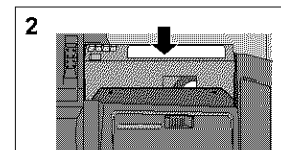
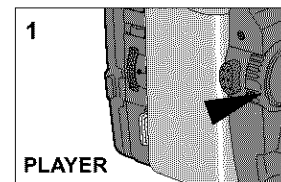

## Basic Recording

### Adjusting the LCD during PLAY

- ❖ You can adjust the LCD during playback.
- ❖ The adjustment method is the same procedure as used in CAMERA mode. (see page 29)

### Controlling Sound from the Speaker

The Speaker works in PLAYER mode only.

- When you use the LCD monitor for playback, you can hear the recorded sound from the built-in Speaker.
  - If you do not want to hear the sound set SPEAKER to OFF in the menu.

1. Set the power switch to PLAYER mode.
2. Press the MENU ON/OFF button.
3. Turn the MENU DIAL to highlight SPEAKER.
4. Press the ENTER button to change the setting.
5. Press the MENU ON/OFF button to finish the SPEAKER setting.
  - If you close the LCD monitor, both the LCD and speaker are switched off.
  - If the speaker does not work properly, check these points;
    - Is the LCD monitor closed?
    - Is the volume adjusted to a low?
    - Is the SPEAKER set to OFF in the menu?

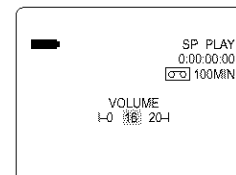
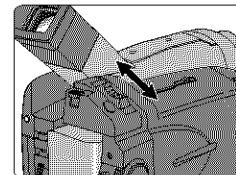
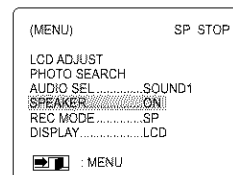

### Volume Control

- ❖ The volume of the Speaker is controlled by moving the ZOOM lever (Volume Control) during playback.

# Advanced Recording

## Using the Various Functions

### ● Setting the menu item

Power switch	CAMERA	PLAYER
Functions in menu	LCD ADJUST, CUSTOM SET, DIS, PIP, DIGITAL ZOOM, PROGRAM AE, DSE SELECT, WHITE BALANCE, SHUTTER SPEED, IRIS, REC MODE, REC LAMP, WIND CUT, AUDIO MODE, PHOTO MODE, DISPLAY, DATE/TIME, DEMO, CLOCK SETTING	LCD ADJUST, PHOTO SEARCH, AUDIO SELECT, SPEAKER, REC MODE, DISPLAY, DATE/TIME

### ● Set the camcorder to CAMERA or PLAYER mode.

1. Press the MENU ON/OFF button.  
The MENU OSD is displayed.
2. Using the MENU DIAL and ENTER buttons on the rear side panel, select and activate the item.
3. You can finish the menu mode by pressing the MENU ON/OFF button.

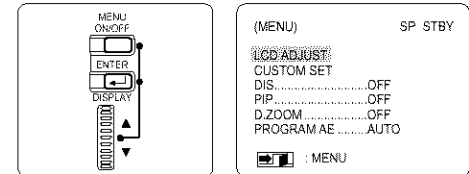

# Advanced Recording

## ● Availability of functions in each mode

Requested Mode Operating Mode	Digital functions				Digital Special Effects	
	DIS	D.ZOOM	PHOTO	PIP	GHOST	OTHER EFFECTS
DIS		○	○	○	×	○
D.ZOOM	○		○	○	○	○
PHOTO	×	×		×	×	×
PIP	○	○	㊦		㊦	㊦
DSE	GHOST	㊦	○	㊦	×	㊦
	OTHER EFFECTS	○	○	○	×	㊦

○ : The requested mode will work with the operating mode.

㊦ : The requested mode will override the operating mode.

×

### Notes

- If the menu item displays **DISABLE** for some functions, you are not able to change that menu setting.
- When you set the IRIS mode to manual (not AUTO) mode,
  - The PROGRAM AE mode will be changed to AUTO.
- When you set the SHUTTER SPEED mode to manual (not AUTO) mode,
  - The PROGRAM AE mode will be changed to AUTO.
- When you set the PROGRAM AE mode to manual (not AUTO) mode,
  - The SHUTTER SPEED and IRIS mode will be changed to AUTO.

# Advanced Recording

## ● LCD ADJUST

- ❖ The LCD ADJUST function works in CAMERA and PLAYER mode.  
Please see page 29.

## ● CUSTOM SET

- ❖ You can customize settings and save them for future use.
  - The CUSTOM SET function operates in CAMERA mode only.
- ❖ If you want to use the CUSTOM function (see page 53) properly, set the status of each item to what you want before using.
- ❖ You can set and store the following items :
  - DIS, PIP, D.ZOOM, PROGRAM AE, DSE, SHUTTER, IRIS.

1. Set the power switch to CAMERA mode.
2. Press the MENU ON/OFF button, to bring up the MENU list.
3. Turning the MENU DIAL, select CUSTOM SET and press the ENTER button.
4. Using the MENU DIAL and ENTER button, set the status of each item to what you want.
5. To store settings and to exit the menu, press the MENU ON/OFF button .

### Notes

- If you want to activate the CUSTOM function, press the CUSTOM button in CAMERA mode.
- If you set the SHUTTER to 1/8 ,1/15 ,1/30, the DIS will be changed to OFF.
- If you set the IRIS to manual, the PROGRAM AE will be changed to AUTO.

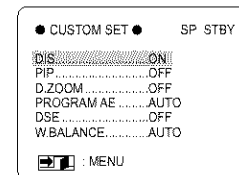
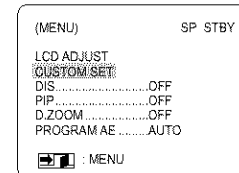

# Advanced Recording

## ● DIS (Digital Image Stabilizer)

- ❖ The DIS function works in CAMERA mode only.
- ❖ DIS(Digital Image Stabilizer) is a handshake compensation function that compensates for any shaking or moving of the hand holding the camcorder (within reasonable limits).
- ❖ It provides more stable pictures when:
  - Recording with the Zoom
  - Recording a small object close-up
  - Recording and walking at the same time
  - Recording through the window of a vehicle

1. Set the camcorder to CAMERA mode.
2. Press the MENU ON/OFF button.
  - The menu list will appear.
3. Turn the MENU DIAL to highlight DIS.
4. To activate the DIS function, press the ENTER button.
  - The DIS menu is changed to ON.
  - If you do not want to use the DIS function, set the DIS menu to OFF.
5. To exit, press the MENU ON/OFF button.

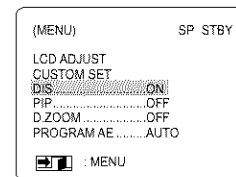
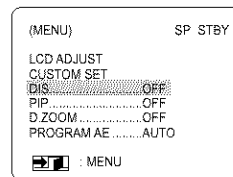

### Notes

- It is recommended that you deactivate the handshake compensation function when using a tripod.
- The DIS function will not operate in the low SHUTTER 1/8 ,1/15 ,1/30 mode.
- If you set the DIS function to ON in GHOST mode, the GHOST mode will be switched off.
- If you use the DIS function, the picture quality may deteriorate.

# Advanced Recording

## ● PIP (Picture-in-Picture)

- ❖ The PIP (Picture-in-Picture) function works in CAMERA mode only.
- ❖ The PIP feature works by using a small, superimposed screen to show an image that is wider than the one being recorded. (Ex. Digital Zoom). This should help you to get a more clear idea of what you are recording.

1. Set the camcorder to CAMERA mode.
2. Press the MENU ON/OFF button.
  - The menu list will appear.
3. Turn the MENU DIAL to highlight PIP.
4. To activate the PIP function, press the ENTER button.
  - The PIP menu is changed to ON.
  - If you do not want to use the PIP function, set the PIP menu to OFF.
5. To exit, press the MENU ON/OFF button.

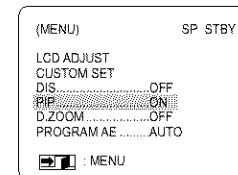
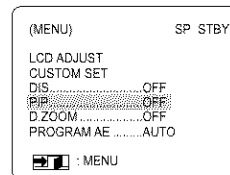

### Notes

- When you use the PIP function, the PIP screen will be recorded on the tape.
- The PIP function will not operate in the DSE function.
- If you set the SHUTTER to manual (1/8, 1/15, 1/30) in PIP mode, the PIP will disappear.

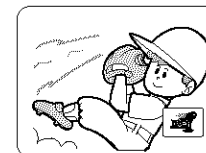



# Advanced Recording

## ● Zooming In and Out with DIGITAL ZOOM

- ❖ Zoom works in CAMERA mode only.

### Zooming In and Out

- ❖ Zooming is a recording technique that lets you change the size of the subject in the scene. For more professional looking recordings, do not use the zoom function too often.
- ❖ You can zoom using a variable zoom speed.
- ❖ Use these features for different shots; Please note that over use of the zoom feature can lead to unprofessional looking results and a reduction of battery usage time.

1. Move the zoom lever a little for a gradual zoom, move it further for a high-speed zoom. Your zooming is monitored on the OSD.
2. T(Telephoto) side:  
Subject appears closer.
3. W(Wide angle) side:  
Subject appears farther away.

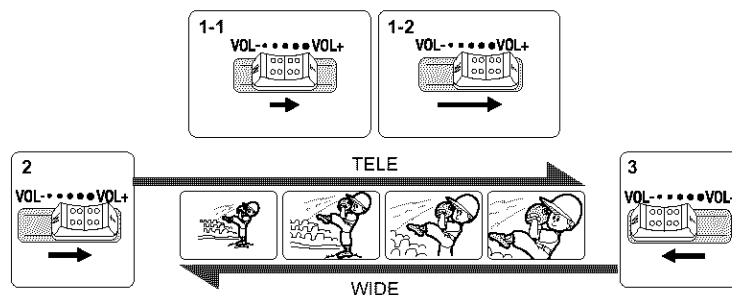

#### Note

You can record a subject that is a minimum of 1 m (about 2.65 feet) away from the lens surface in the TELE position, or about 10 mm (about 0.5 inch) away in the WIDE position.

# Advanced Recording

## Digital Zoom

- ❖ Zooms more than 22x are performed digitally.
- ❖ The picture quality deteriorates the more you zoom in on the subject.
- ❖ We recommend that you use the DIS feature with the DIGITAL ZOOM for picture stability.

1. Set the camcorder to CAMERA mode.

2. Press the MENU ON/OFF button.

- The menu list will appear.

3. Turn the MENU DIAL to D.ZOOM.

4. Press ENTER to enter the sub-menu.

5. Turn the MENU DIAL so that it highlights the zoom magnification.

- Press ENTER to activate the digital zoom and return to main menu.
- If you exit the sub-menu without pressing the ENTER button, the DIGITAL ZOOM mode is not changed.

6. To exit, press the MENU ON/OFF button.

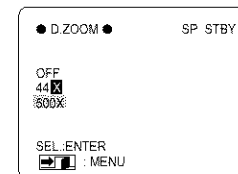
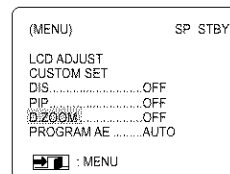

### Note

- If you use the digital zoom function, the picture quality may deteriorate.

# Advanced Recording

## ● PROGRAM AE

- ❖ The PROGRAM AE function works in CAMERA mode only.
- ❖ The PROGRAM AE modes allow you to adjust shutter speeds and apertures to suit different recording conditions.
- ❖ They give you creative control over the depth of field.

## ■ AUTO mode

- Auto balance between the subject and the background.
- To be used in normal conditions.
- The shutter speed automatically varies from 1/60 to 1/250 second, depending on the scene.

## ■ PORTRAIT mode ( )

- For focusing on the background of the subject, when the background is out of focus.
- The PORTRAIT mode is most effective when used outdoors.
- The shutter speed automatically varies from 1/60 to 1/1000 second.

## ■ SPORT mode ( )

- For recording people or objects moving quickly.

## ■ HSS mode ( )

- For recording fast-moving subjects such as golfers or tennis players.

## Setting the PROGRAM AE

1. Press the MENU ON/OFF button.
  - The menu list will appear.
2. Turn the MENU DIAL to highlight PROGRAM AE.
3. Press ENTER to enter the sub-menu.
4. Using the MENU DIAL, select the PROGRAM AE mode.
  - Press ENTER to confirm the PROGRAM AE mode.
5. To exit, press the MENU ON/OFF button.

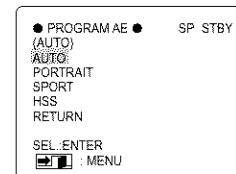
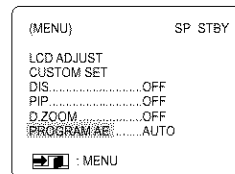

# Advanced Recording

## ● DSE(Digital Special Effects) SELECT

- ❖ The DSE function works in CAMERA mode only.
- ❖ The digital effects enable you to give a creative look to your recording by adding various special effects.
- ❖ Select the appropriate digital effect for the type of picture that you wish to record and the effect that you wish to give.
- ❖ There are 10 DSE modes.

- a. ART mode  
This mode gives the images a coarse effect.
- b. MOSAIC mode  
This mode gives the images a mosaic effect.
- c. SEPIA mode  
This mode gives the images a reddish-brown pigment.
- d. NEGA mode  
This mode reverses the colors of the image creating a negative image.
- e. MIRROR mode  
This mode cuts the picture in half, using a mirror effect.
- f. B/W mode  
This mode changes the images to black and white.
- g. EMBO mode  
This mode creates a 3D effect (embossing).
- h. CINEMA mode  
This mode covers the upper/lower portions of the screen to give a movie-like effect.
- i. MAKE UP mode  
This mode allows the images to be selected in red, yellow, green or blue colors.
- j. GHOST mode  
This mode gives the images a dragging effect.

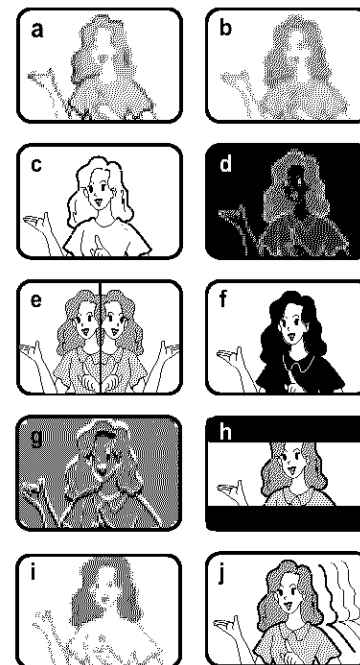

# Advanced Recording

## Selecting an effect

1. Set the camcorder to CAMERA mode.
2. Press the MENU ON/OFF button.
  - The menu list will appear.
3. Turn the MENU DIAL to highlight DSE SELECT.
4. Press ENTER to enter the sub-menu.
5. Using the MENU DIAL, select the DSE mode.
  - Press ENTER to confirm the DSE mode.
    - In MAKE-UP mode, a MENU list for selecting RED/GREEN/BLUE/YELLOW will appear.
6. To exit, press the MENU ON/OFF button.

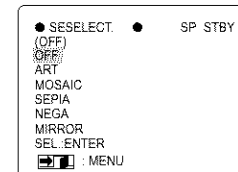
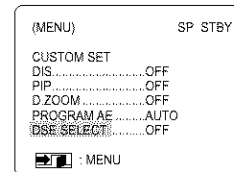
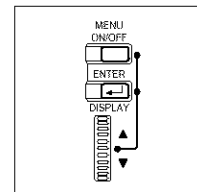

### Notes

- PIP will shut off when the DSE mode is operated.
- GHOST function will not operate in DIS and 1/8, 1/15, 1/30 SHUTTER modes.

## Advanced Recording

### ● W.BALANCE (WHITE BALANCE)

- ❖ The WHITE BALANCE function works in CAMERA mode only.
- ❖ The WHITE BALANCE is a recording function that preserves the unique color of the object in any recording condition.
- ❖ You may select the appropriate WHITE BALANCE mode to obtain a good quality color of the image.
  - AUTO : This mode is generally used to control the WHITE BALANCE automatically.
  - HOLD : Fixes the current WHITE BALANCE value.
  - INDOOR : Controls WHITE BALANCE according to the indoor ambience.
  - OUTDOOR : Controls WHITE BALANCE according to the outdoor ambience.

1. Set the camcorder to CAMERA mode.
2. Press the MENU ON/OFF button.
  - The menu list will appear.
3. Turn the MENU DIAL to highlight W.BALANCE.
4. Press ENTER to enter the sub-menu.
5. Using the MENU DIAL, select the WHITE BALANCE mode.
  - Press ENTER to confirm the WHITE BALANCE mode.
6. To exit, press the MENU ON/OFF button.

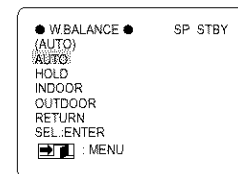
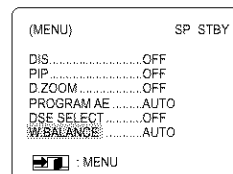

# Advanced Recording

## ● SHUTTER

- ❖ The SHUTTER SPEED function works in CAMERA mode only.
- ❖ The shutter speed can be controlled, allowing you to record both fast and slow moving objects.
  - You can select one of the following.
    - AUTO, 1/8, 1/15, 1/30, 1/60, 1/100, 1/250, 1/500, 1/1000, 1/2000, 1/4000, 1/10000 second.
    - AUTO is fixed at 1/60 second.

1. Set the camcorder to CAMERA mode.
2. Press the MENU ON/OFF button.
  - The menu list will appear.
3. Turn the MENU DIAL to highlight SHUTTER.
4. Press ENTER to enter the sub-menu.
5. Using the MENU DIAL, select the SHUTTER SPEED mode.
  - Press ENTER to confirm the SHUTTER SPEED mode.
6. To exit, press the MENU ON/OFF button.

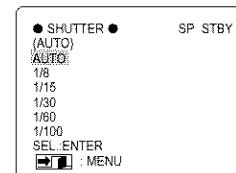
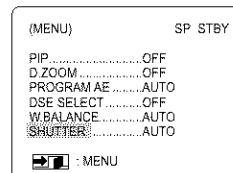

### Note

- The SHUTTER SPEED function will not operate with either the DIS ON or the GHOST modes ON.

## Advanced Recording

### ● IRIS

- ❖ The IRIS function works in CAMERA mode only.
- ❖ The IRIS controls the quantity of light entering through the lens.
- ❖ If you select a higher value, the iris opens, and the image will be brighter.  
If you select a lower value, the iris closes, and the image will be darker.
  - You can select one of the following.

AUTO : It selects the iris value for the proper exposure.

MANUAL: 0 ~ 29

1. Set the camcorder to CAMERA mode.
2. Press the MENU ON/OFF button.
  - The menu list will appear.
3. Turn the MENU DIAL to highlight IRIS.
4. Press ENTER to enter the sub-menu.
  - If you want to use manual mode, select MANUAL and press ENTER.
  - Using the MENU DIAL, select the IRIS value.
5. To exit, press the MENU ON/OFF button.

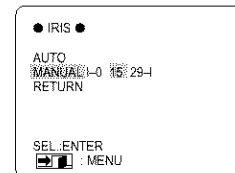
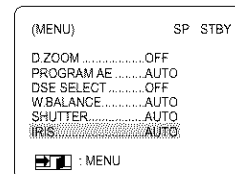



# Advanced Recording

## ● REC MODE

- ❖ The REC MODE function works in both CAMERA and PLAYER modes.
- ❖ This camcorder records and plays back in SP (standard play) mode and in LP (long play) mode.
  - SP (standard play): This mode permits 60 minutes of recording time with a DVM60 tape.
  - LP (long play): This mode permits 90 minutes of recording time with a DVM60 tape.

1. Set the camcorder to CAMERA or PLAYER mode.
2. Press the MENU ON/OFF button.
  - The menu list will appear.
3. Turn the MENU DIAL to highlight REC MODE.
4. To select the REC MODE, press the ENTER button.
  - The REC MODE is switches between SP and LP with each press.
5. To exit, press the MENU ON/OFF button.

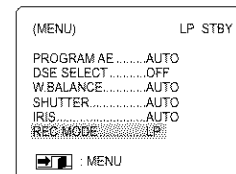
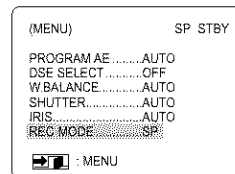

### Notes

- We recommend that you use this camcorder to play back any tape recorded on this camcorder. Playing back a tape recorded in other equipment may produce mosaic shaped noise.
- When you record in SP and LP modes on one tape or you record some scenes in LP mode, the playback picture may be distorted or the time code may not be written properly between scenes.
- Record using SP mode for best picture and sound quality.

## Advanced Recording

### ● REC LAMP

- ❖ The REC LAMP function works in CAMERA mode only.
- ❖ You can turn the REC indicator on or off during recording.

1. Set the camcorder to CAMERA mode.
2. Press the MENU ON/OFF button.
  - The menu list will appear.
3. Turn the MENU DIAL to highlight REC LAMP.
4. To turn the REC lamp indicator ON or OFF during recording, press the ENTER button.
  - The REC LAMP menu is changed to ON or OFF respectively.
  - If you want to turn off the indicator, set the REC LAMP to OFF.
5. To exit, press the MENU ON/OFF button.

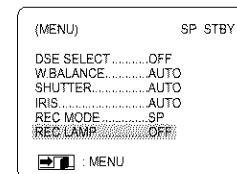
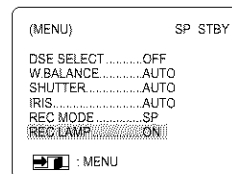

### ● WIND CUT

- ❖ The WIND CUT function works in CAMERA mode only.
- ❖ The WIND CUT function minimizes wind noise or other noise during recording.
  - When the wind cut is on, some low sounds are cut out along with the sound of the wind.
- ❖ The WIND CUT menu selecting method is the same as the REC LAMP.

# Advanced Recording

## ● AUDIO MODE

- ❖ The AUDIO MODE function works in CAMERA mode only.
- ❖ This camcorder records the sound in two ways. (12 BIT, 16 BIT)
  - 12 BIT: You can record two 12 bit stereo sound tracks.  
The original stereo sound can be recorded onto the MAIN (SOUND1) track.  
Additional stereo sound can be dubbed onto the SUB (SOUND2) track (SCD70 only).
  - 16 BIT: You can record one high quality stereo sound track using the 16 bit recording mode.  
Audio dubbing is not possible when using this mode.

1. Set the camcorder to CAMERA mode.
2. Press the MENU ON/OFF button.
  - The menu list will appear.
3. Turn the MENU DIAL to highlight AUDIO MODE.
4. To select the AUDIO MODE, press the ENTER button.
  - The AUDIO MODE is switches between 12 BIT - 16 BIT with each press.
5. To exit, press the MENU ON/OFF button.

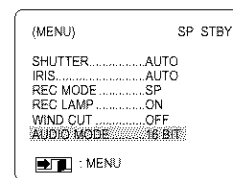
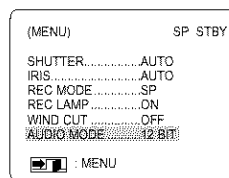

### Note

- SCD67 cannot record dubbed audio. However, it can play back 12 BIT dubbed audio recorded on other camcorders.

# Advanced Recording

## ● DISPLAY

- ❖ The DISPLAY function works in both CAMERA and PLAYER modes.
- ❖ You can select the output path for the OSD (On Screen Display).
- ❖ There are two ways;
  - LCD: The OSD appears in the LCD monitor and EVF only.
  - LCD/V-OUT: The OSD appears in the LCD monitor, EVF and TV.

1. Set the camcorder to CAMERA or PLAYER mode.
2. Press the MENU ON/OFF button.
  - The menu list will appear.
3. Turn the MENU DIAL to highlight DISPLAY.
4. To select the DISPLAY mode, press the ENTER button.
  - The DISPLAY mode switches between LCD-LCD/V-OUT with each press.
5. To exit, press the MENU ON/OFF button.
6. To turn the OSD ON or OFF, press the ENTER button.

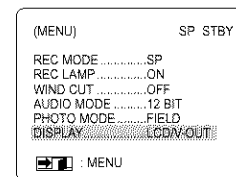
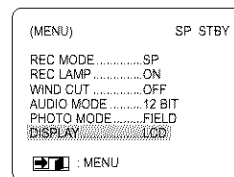

# Advanced Recording

## ● DATE/TIME

- ❖ The DATE/TIME function works in both CAMERA and PLAYER mode.
- ❖ The date and time is automatically recorded on a special data area of the tape.
- ❖ You can choose what you want to display - either the date, the time or both.
  - DATE only
  - TIME only
  - DATE/TIME

1. Press the MENU ON/OFF button.
  - The menu list will appear.
2. Turn the MENU DIAL to DATE/TIME.
3. Press ENTER to enter the sub-menu.
4. Using the MENU DIAL, select the DATE/TIME mode.
  - Press ENTER to confirm the DATE/TIME mode and return to the main menu.
  - If you exit the sub-menu without pressing ENTER, the DATE/TIME mode is not changed.
5. To exit, press the MENU ON/OFF button.

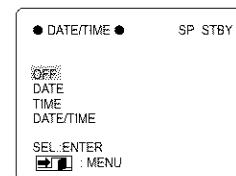
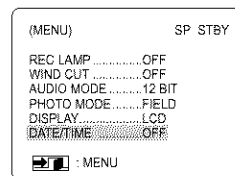

### Notes

- The DATE/TIME is not affected by the OSD ON/OFF (ENTER) button.
- The DATE/TIME will read “----” in the following conditions.
  - During playback of a blank section of tape.
  - If the tape was recorded before setting the DATE/TIME in the camera's memory.
  - When the Lithium Battery becomes weak or dead.

## Advanced Recording

### ● DEMO

- ❖ Demonstration automatically shows you the major functions that are included with your camcorder so that you may use them more easily.
- ❖ The DEMO function is only available in CAMERA mode when you are not recording.
- ❖ The demonstration operates repeatedly until the DEMO mode is set OFF.

1. Set the camcorder to CAMERA mode.
2. Press the MENU ON/OFF button.
  - The menu list will appear.
3. Turn the MENU DIAL to highlight DEMO.
4. To activate the DEMO function, press the ENTER button so DEMO...ON appears.
  - Press the menu button to quit the menu.
  - The demonstration will start.
5. To end the demonstration, set the DEMO to OFF.

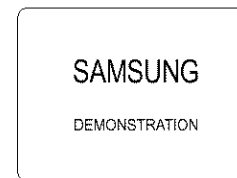
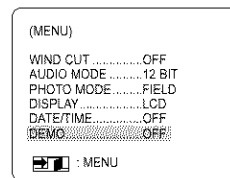

### Notes

- The DEMO function only works without a TAPE inserted.
- If you set the DEMO to ON during recording or STBY mode, the demonstration will activate 3 minutes later after the tape is ejected.
- If you press other buttons (ZOOM, FADE, BLC, PHOTO, EASY, CUSTOM) during the DEMO mode, the DEMO stops. The DEMO mode will resume in 3 minutes if no other buttons are pressed.

# Advanced Recording

## ● CLOCK SET

- ❖ The CLOCK can only be set in the CAMERA mode.
- ❖ The DATE/TIME is automatically recorded on a tape.  
Before recording, set the DATE/TIME.

1. Press the MENU ON/OFF button.
  - The menu list will appear.
2. Turn the MENU DIAL to highlight CLOCK SET.
3. Press the ENTER button to enter the SETTING mode.
  - BLINKING indicates the setting to be changed,  
The year will be the first to blink.
4. Using the MENU DIAL, change the year setting.
5. Press the ENTER button.
  - The month will blink.
6. Using the MENU DIAL, change the month setting.
7. Press the ENTER button.
  - The day will blink.
8. You can set the day, hour and minute following the same procedure used for setting the year and month.
9. Press ENTER after setting the minute.
  - The **COMPLETE!** OSD will blink, and then a few seconds later, the menu screen will return to the main menu.

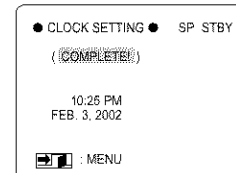
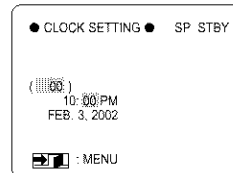
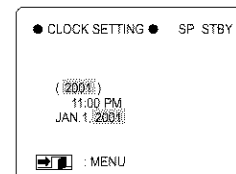
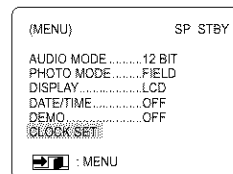

## ENGLISH

# Advanced Recording

### *EASY Mode (for Beginners)*

- ❖ Even a beginner can make a recording using the EASY mode.
  - The EASY mode only operates in CAMERA mode.
  
- 1. Set the power switch to CAMERA mode.
  
- 2. By pressing the EASY button, all the functions on the camera will be set to off and the recording settings will be set to the following basic mode.
  - Battery level, recording mode, counter, DATE/TIME, DIS (  ) will be displayed.
  - The word "EASY" will appear on the LCD at the same time.  
The DATE/TIME will only be seen if it has been set.  
(see page 49)
  
- 3. Press START/STOP to start recording.
  - Recording will begin using the basic automatic settings.
  
- 4. Pressing the EASY button again turns the EASY mode off.
  - The camera will return to the settings that were set prior to the EASY mode being switched on.

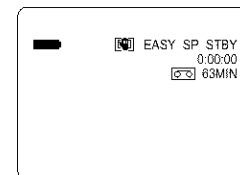
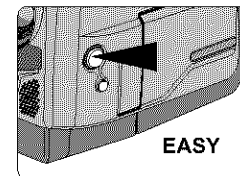

### Notes

- In the EASY mode, BLC, FADE, MF/AF and all MENU functions are not available.
  - If you want to use these functions, you must first switch the EASY mode off.
- The EASY mode settings are stored in the camera (provided a good lithium battery has been installed).



# Advanced Recording

## *CUSTOM Mode*

- ❖ You can customize settings and save them for future use.
    - The CUSTOM SET function operates in CAMERA mode only.
  - ❖ Please set custom settings before using this function. (see page 34)
1. Set the power switch to CAMERA mode.
  2. To activate the CUSTOM function, press the CUSTOM button.
    - "CUSTOM" will be displayed on the screen.
  3. Press START/STOP to start recording.
    - Recording will begin using the CUSTOM settings.
  4. To switch the CUSTOM mode off, press the CUSTOM button again.
    - The camcorder will revert to the settings that were set prior to the custom mode being selected.

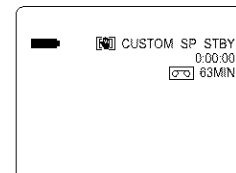
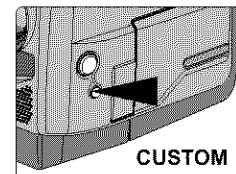

### Notes

- Once settings have been made in the Custom mode, you turn the Custom mode off to make changes to these settings.
- The CUSTOM settings will be stored in the camera (providing a good lithium battery has been installed).

# Advanced Recording

## MF/AF (Manual Focus/Auto Focus)

- ❖ The MF/AF function works in CAMERA mode only.
- ❖ In most situations, it is better to use the automatic focus feature, as it enables you to concentrate on the creative side of your recording.
- ❖ Manual focusing may be necessary under certain conditions that make automatic focusing inadequate.

### Auto Focusing

- ❖ If you are inexperienced with camcorders, we recommend that you make use of the Auto Focus mode.

### Manual Focusing

- ❖ In the following cases you could obtain better results by adjusting the focus manually.
    - a. A picture containing several objects, some close to the camcorder, others further away.
    - b. A person enveloped in fog or surrounded by snow.
    - c. Very shiny or glossy surfaces like a car.
    - d. People or objects moving constantly or quickly such as an athlete or crowd.
1. Set power switch to CAMERA mode.
  2. Press MF/AF (  ) button.
  3. Turn MF DIAL (MENU DIAL) up or down until the object is focused.
    - Zoom out a little if focusing is difficult.
  4. To return to AF(Auto Focus), press the MF/AF button again.

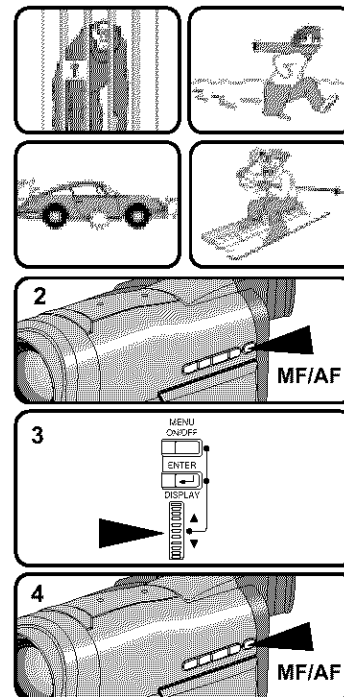

# Advanced Recording

## ***BLC (Back Light Compensation)***

- ❖ BLC works in CAMERA mode.
  - ❖ Back lighting exists when the subject is darker than the background:
    - The subject is placed in front of a window.
    - The person to be recorded is wearing white or shiny clothes and is placed against a bright background; the person's face is too dark to distinguish their features.
    - The subject is outdoors and the background is overcast.
    - The light sources are too bright.
    - The subject is against a snowy background.
1. Set the POWER switch to CAMERA mode.
  2. Press the BLC button.
    - Normal - BLC - Normal
    - BLC enhances only the subject.

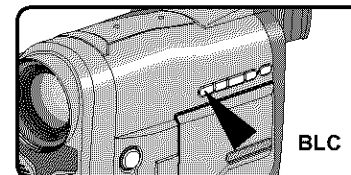
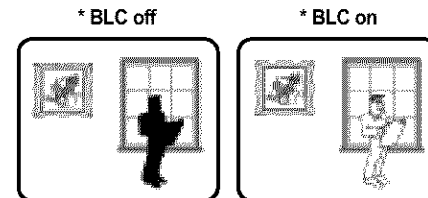

# Advanced Recording

## Fade In and Out

- ❖ The FADE function works in CAMERA mode only.
- ❖ You can give your films a professional look by using special effects such as fade in at the beginning of a sequence or fade out at the end of a sequence.

### To Start Recording

1. Before recording, hold down the FADE button.  
The picture and sound gradually disappear (fade out).
2. Press the START/STOP button and at the same time release the FADE button.  
Recording starts and the picture and sound gradually appear (fade in).

### To Stop Recording (use FADE IN / FADE OUT)

3. When you wish to stop recording, hold down the FADE button.  
The picture and sound gradually disappears (fade out).
4. When the picture has disappeared, press the START/STOP button to stop recording.

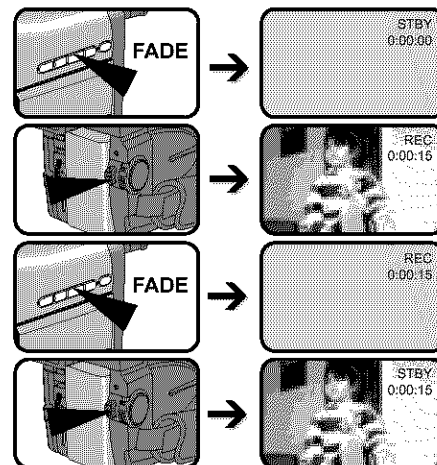

- a. **FADE OUT**  
(Approx. 4 seconds)

- b. **FADE IN**  
(Approx. 4 seconds)

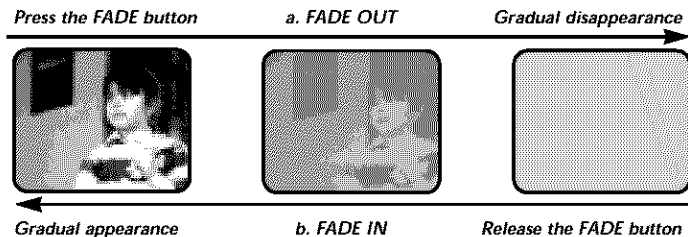

# Advanced Recording

## Audio dubbing (SCD70 only)

- ❖ The AUDIO DUBBING function only works in PLAYER Mode.
- ❖ You can add sound to the original sound on a pre-recorded tape, recorded in the SP mode with 12bit sound.
- ❖ Use the internal, or an external microphone.
- ❖ The original sound will not be erased.

### Dubbing sound with a microphone

1. Set the camcorder to PLAYER mode.
  - If you want to use the external microphone, connect the microphone to the external MIC input on the camcorder.
2. Press ►/II (PLAY/STILL) button and find the start position of the scene to be dubbed.
3. Press ►/II (PLAY/STILL) button to pause the scene.
4. Press the A.DUB button on the Remote Control.
  - A.DUB will be displayed in the LCD.
  - The camcorder is in a ready-to-dub state.
5. Press the ►/II (PLAY/STILL) button to start dubbing.
  - Press the ■(STOP) button to stop the dubbing.

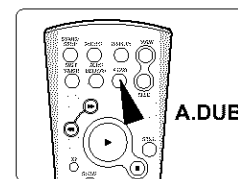
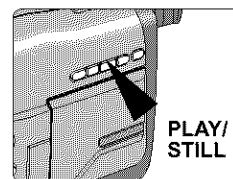
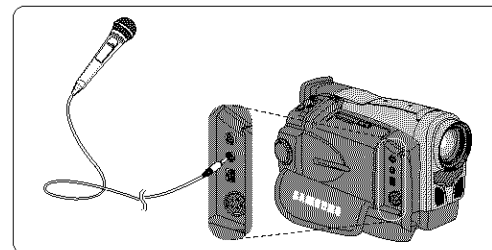

#### Note

- You can not dub sound on a pre-recorded tape recorded in LP mode or 16 bit mode.

## ENGLISH

# Advanced Recording

### Playing back dubbed Audio

1. Insert the dubbed tape and press the MENU ON/OFF button.
2. Turn the MENU DIAL to highlight AUDIO SEL.
3. Press ENTER to enter the sub-menu.
4. Using the MENU DIAL, select the AUDIO playback channel.
  - Press ENTER to confirm the audio playback channel and return to main menu.
    - SOUND1 : play back the original sound.
    - SOUND2 : play back the dubbed sound.
    - MIX : play back SOUND1 and 2 equally mixed.
5. To exit, press the MENU ON/OFF button.

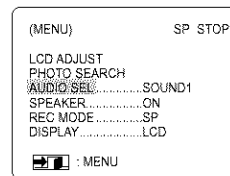

### Notes

- When you play back added sound (SOUND2 or MIX mode), there may be some loss in sound quality.
- SCD67 cannot record dubbed audio. However, it can play back 12 BIT dubbed audio recorded on other camcorders.

## PHOTO

- ❖ The PHOTO function works in CAMERA mode only.
- ❖ The PHOTO function lets you capture an object as a still along with sound, while in CAMERA mode.
- ❖ You can select one of these PHOTO modes;
  - FIELD : You can record a normal resolution still picture.
  - FRAME: You can record a high resolution still picture.
    - If you shoot a fast moving subject in this mode, you may get a duplicated still picture.
    - We recommend you use this mode to shoot a motionless picture.

## Advanced Recording

1. Set the camcorder to CAMERA.
2. Press the MENU ON/OFF button.
  - The menu list will appear.
3. Turn the MENU DIAL to highlight PHOTO MODE.
4. To select the PHOTO MODE, press the ENTER button.
  - The PHOTO MODE switches between FIELD and FRAME with each press.
5. To exit, press the MENU ON/OFF button.

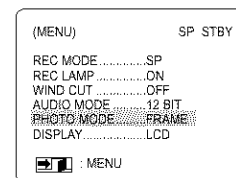
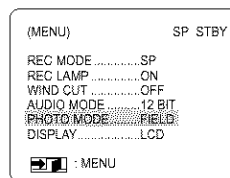

### Taking still pictures

1. Press the PHOTO button.
  - The still picture appears on the LCD monitor or viewfinder.
  - To quit the PHOTO mode without recording, press the PHOTO button again.
2. Press the START/STOP button.
  - The still picture (with audio) is recorded for about 8 seconds.
3. After the PHOTO recording, PHOTO mode is canceled.

#### Notes

- To record the still picture, you must press the START/STOP button.
- If you press the PHOTO button in the GHOST or PIP mode, the GHOST or PIP mode will be shut off.
- If you use the PHOTO function, the picture quality may deteriorate.

### Searching for PHOTO pictures

- ❖ PHOTO SEARCH works in the PLAYER mode only.

1. Press the MENU ON/OFF button.
  - The menu list will appear.
2. Turn the MENU DIAL to highlight PHOTO SEARCH.
3. Press ENTER to enter the sub-menu.
4. Using the MENU DIAL, select the search direction
  - Press the ENTER button.
  - After searching, the camcorder displays the still image and the screen will automatically return to main menu.
5. To exit, press the MENU ON/OFF button.

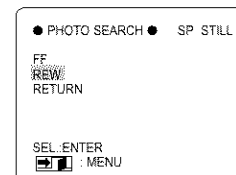
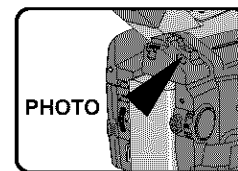

# Advanced Recording

## Lighting Techniques

- ❖ The single greatest influence on picture quality is the level of light, measured in lux.
- ❖ The following table lists a few common conditions of usage, along with the corresponding level of brightness and any associated lighting recommendations.

Situations	Brightness(Lux)	Recommendations
<ul style="list-style-type: none"> <li>• Snow-covered mountains or fields.</li> <li>• Sandy beach on a hot summer's day.</li> </ul>	100,000	ND filter recommended.
<ul style="list-style-type: none"> <li>• Sunny around midday.</li> <li>• Sunny day in the middle of the afternoon.</li> <li>• Overcast day around midday.</li> <li>• Overcast day one hour after sunrise.</li> <li>• Office with fluorescent lighting near to a window.</li> <li>• Sunny day one hour before sunset.</li> <li>• Department store counter.</li> <li>• Station ticket counter.</li> </ul>	100,000 35,000 32,000 2,000 1,000 1,000 500 to 700 650	Normal recording.
<ul style="list-style-type: none"> <li>• Office with fluorescent lighting.</li> <li>• Room lit by two 30W fluorescent lights.</li> </ul>	400 to 500 300	-
<ul style="list-style-type: none"> <li>• Arcade at night.</li> <li>• Theater (theatre) lobby.</li> <li>• Candle light.</li> </ul>	150 to 200 15 to 30 10 to 15	-

## After Recording

1. Eject the tape you have recorded. (see page 25)
2. If you want to protect a tape against accidental erasure, move the protective tab on the cassette.
3. Set the POWER switch to OFF.
4. Close the LENS cover.
5. Remove the BATTERY PACK from the camcorder.



# Advanced Recording

## Various Recording Techniques

- ❖ In some situations different recording techniques may be required for better results.

### Note

Please rotate the LCD screen carefully.  
Over rotation may cause damage to the inside of the hinge that connects the LCD screen to the Camcorder.

### 1. General recording.



### 2. Downward recording.

Making a recording by looking at the LCD screen from the top.

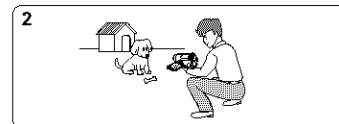

### 3. Upward recording.

Making a recording by looking at the LCD screen from the bottom.



### 4. Self record

Making a recording by looking at the LCD screen from the front.



### Note

When the LCD screen faces front, indicators are turned off.

### 5. Recording with Viewfinder.

- In circumstances where it is difficult to use the LCD monitor, the viewfinder can be used as a convenient alternative.



## ENGLISH

# Playing back a Tape

- ❖ To watch a tape you recorded.
- ❖ Playback function works in PLAYER mode only.
- ❖ There are two ways to watch a tape;
  - To watch with on the LCD : recommended for outdoor use.
  - To watch with on a TV monitor : recommended for indoor use.

## To watch with the LCD

- ❖ View a tape using the LCD when a TV is not available.

## To watch with a TV monitor

- ❖ View a tape using a TV monitor while indoors.
- ❖ To play a tape back, the TV must feature a compatible color system.
- ❖ We recommend that you use the AC Power Adapter as the power source of the camcorder.

### Connecting to a TV with Audio and Video input jacks

- ❖ Use the Audio/Video cable supplied with your camcorder.
  - The yellow plug : Video
  - The white plug : Audio(L)
  - The red plug : Audio(R)

### Notes

- You can use the S-VIDEO cable (SCD70, not supplied with SCD67) to obtain better quality pictures if you have a S-VIDEO connector on your TV.
- Even if you use S-video cable, you must still connect an audio cable.
- While playing back on a TV screen, close the LCD panel. Otherwise, picture distortion may occur.

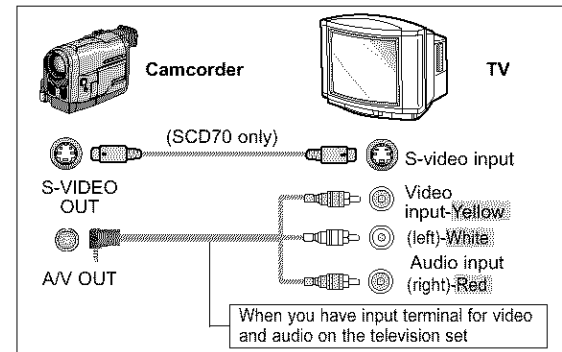

## Playing back a Tape

### Connecting to a TV which has no Audio and Video input jacks

- ❖ You can connect your camcorder to a TV through a VCR.
  - Set the input selector on the VCR to LINE.
  - The yellow plug : Video
  - The white plug : Audio(L)
  - The red plug : Audio(R) – STEREO only
- ❖ To view the cassette on the television screen, select the channel reserved for your VCR on the television.  
(Refer to your VCR or television instruction book)

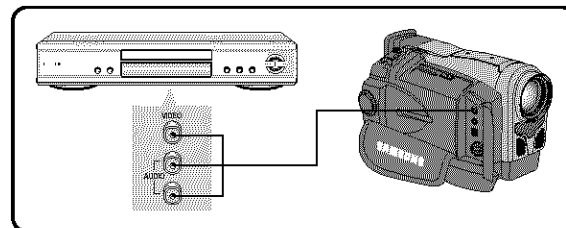

### Playback

- ❖ You can play the recorded tape in PLAYER mode.
  1. Use the TV/VIDEO button to select VIDEO on your TV.
  2. Connect a power source (battery or AC Power adapter) to the camcorder.
  3. Set the POWER switch to PLAYER.
  4. Insert the tape you want to see.
  5. Using ►► (FF) and ◀◀ (REW) buttons, find the part of the tape you want to see.
  6. Press the ►/|| (PLAY/STILL) button.
    - The picture you recorded appears on the TV after a few seconds.
    - If the tape reaches its end during playback, the tape will rewind automatically.

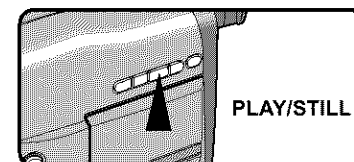
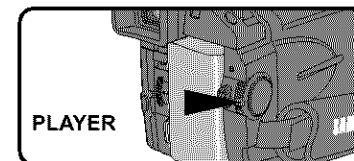

#### Notes

- It is best to decrease the volume of the built-in speaker when your camcorder is connected to the TV.
- The playback mode (SP/LP) is selected automatically.

## Playing back a Tape

### Various Functions in PLAYER mode

- ❖ The PLAY/STILL, STOP, FF, REW, SLOW buttons are located on the camcorder and the Remote Control (SCD70 only).
- ❖ The F.ADV(Frame advance), X2 buttons are located on the Remote Control only.
- ❖ To prevent tape and head-drum wear, your camcorder will automatically stop if it is left for more than 3 minutes in STILL or SLOW mode.

### Playback pause

- ❖ Press the ►/|| (PLAY/STILL) button during Playback or Slow playback
- ❖ To resume playback, press the ►/|| (PLAY/STILL) button.

### Picture search (Forward/Reverse)

- ❖ Press ►► (FF) or ◀◀ (REW) buttons once during Playback or Still mode.  
To resume normal playback, press the ►/|| (PLAY/STILL) button.
- ❖ Keep pressing ►► (FF) or ◀◀ (REW) buttons during Playback or Still mode.  
To resume normal playback, release the button.

### Slow playback (Forward/Reverse)

- ❖ Forward Slow Playback
  - Press the SLOW button during Playback.
  - To resume normal playback, press the ►/|| (PLAY/STILL) button.
- ❖ Reverse slow playback
  - Press the ◀◀(REW) button during Forward Slow Playback.
  - To resume forward slow playback, press the ►► (FF) button.
  - To resume normal playback, press the ►/|| (PLAY/STILL) button.

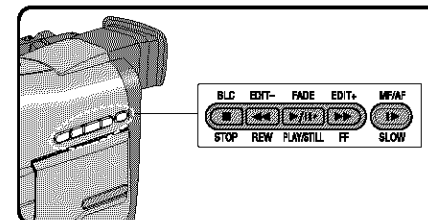

## Playing back a Tape

### Frame advance (To playback frame by frame) (SCD70 only)

- ❖ Press the F.ADV button on the Remote Control in Still mode.  
The F.ADV function works in still mode only.
- ❖ To resume normal playback, press the ►|| (PLAY/STILL) button.

### X2 Playback (Forward/Reverse) (SCD70 only)

- ❖ Forward X2 Playback
  - Press the X2 button on the Remote Control during Playback.
  - To resume normal playback, press the ►|| (PLAY/STILL) button.
- ❖ Reverse X2 Playback
  - Press the ◀◀ (REW) button during Forward X2 Playback.
  - To resume normal playback, press the ►|| (PLAY/STILL) button.

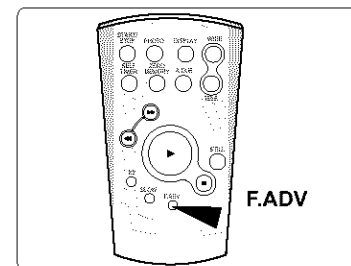

#### Notes

- Mosaic shaped noise appears on the screen during some playback modes.
  - Mosaic shaped noise can be experienced more when you playback tapes recorded in LP containing various playback functions.
- There is no sound when using some playback functions.

ENGLISH

## Playing back a Tape

### ZERO MEMORY (SCD70 only)

- ❖ The ZERO MEMORY function works in both CAMERA and PLAYER modes.
  - ❖ You can mark a point on a tape that you want to return to following playback.
1. Press the ZERO MEMORY button on the remote control during playback or recording at the point you want to return to later.
    - The time code is changed to a tape counter that is set to zero with the **M** (Zero memory indicator).
    - If you want to cancel the zero memory function, press the ZERO MEMORY button again.
  2. Find the zero position.
    - When you finish playback, fast forward or rewind the tape.
      - The tape stops automatically when it reaches the zero position.
    - When you finish recording, turn the power switch PLAYER and press the **◀** (REW) button.
      - The tape stops automatically when it reaches the zero position.
  3. The tape counter with the **M** (Zero memory indicator) disappears from the display and the tape counter is changed to time code.

#### Notes

- In the following situations, the ZERO MEMORY mode may be canceled automatically
  - After returning to the zero position.
  - When the tape is ejected.
  - When you remove the battery pack or power supply.
- The zero memory may not function correctly where there is a break between recordings on the tape.
- The ZERO MEMORY will not operate in DV IN mode.

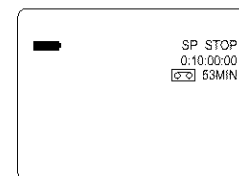
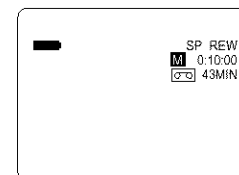
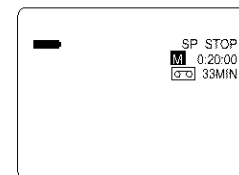

# IEEE 1394 Data Transfer

## Transferring IEEE1394 (i.LINK)-DV standard data connection

### Connecting with DV device

- ❖ Connecting with other DV standard products.
  - DV standard connecting is quite simple. If a product has a DV port, you can transfer data by connecting to the DV port with the correct cable.
  - !!! Be careful. There are two types of DV port. (4pin, 6pin)  
This camcorder has a 4pin terminal.
- ❖ With digital connection, video and audio signals are transmitted in digital, allowing high quality images to be transferred.

### Connecting to a PC

- ❖ If you want to transmit data to a PC, you must install an IEEE 1394 add-on card (not supplied) on the PC.
- ❖ The frame rate recorded for video capturing is dependent on the capability of the PC.

#### Note

- When you transmit data from this camcorder to another DV device, some functions may not work. In this occurs, reconnect the DV cable or turn the power OFF and ON again.

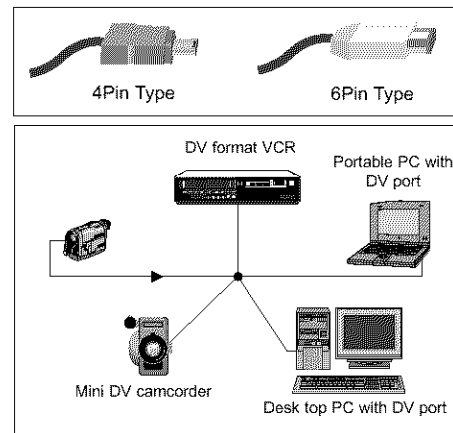

ENGLISH

## IEEE 1394 Data Transfer

### ● System requirements

- CPU : faster Intel® Pentium III™ 450Mhz compatible
- Operating system: Windows® 98SE, ME, XP, Mac OS
- Main memory: more than 64 MB RAM
- IEEE1394 add-on card or built in IEEE1394 card

### Recording with DV connecting cable

1. Set the power switch to PLAYER mode.
2. Connect the DV cable (not supplied) to the DV IN/OUT port of camcorder and to the DV IN/OUT port of the other DV device.
  - Make sure DV IN appears on the monitor.
3. Press the START/STOP button to enter the REC PAUSE mode.
  - PAUSE is displayed in the OSD.
4. Start playback on the other DV device while you monitor the picture.
5. Press the START/STOP button to start recording.
  - If you want to pause recording for a while, press the START/STOP button again.
6. To stop recording, press the ■(STOP) button.

Note

- When making recordings on the camcorder, the pictures on the LCD or a TV monitor may occasionally be uneven, however recorded pictures are not affected.

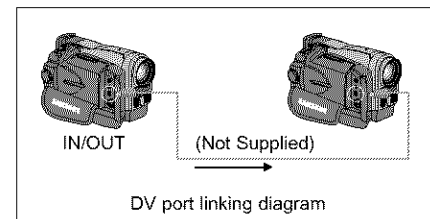
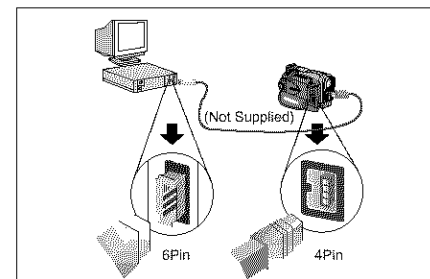



# Maintenance

## *After finishing a recording*

- ❖ At the end of a recording you must remove the power source.
- ❖ Leaving the battery pack on the camcorder after completing recording can reduce the life span of the battery.

## **After completing a recording session**

1. Slide the EJECT switch in the direction of the arrow
  - Opening the cassette door ejects the tape automatically.
  - Wait until the tape is completely ejected.
2. After removing the tape, close the door and store the camcorder in a dust free environment.
  - Dust and other foreign materials can cause image degradation.
3. Set the power switch to OFF mode.
4. Disconnect the power source or remove the Lithium Ion Battery Pack.
  - When connecting a power supply, separate it in reverse order by referring to page 21.
  - Hold down the BATT. RELEASE button and slide the battery pack in the direction of the arrow.

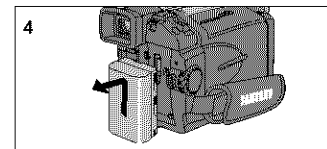
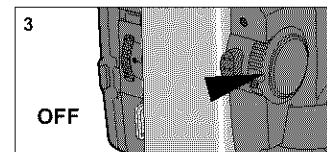
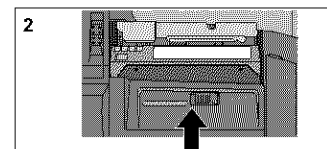
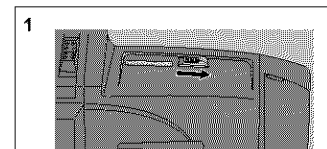

# Maintenance

## Cleaning and Maintaining the Camcorder

### Cleaning the viewfinder

- Releasing the Eyecup
  1. Pull the VIEWFINDER up and then turn the two screws counter-clockwise.
  2. Pull EYECUP out.
  3. Clean the EYECUP and the VIEWFINDER screen with a soft cloth and cotton swab or a blower.
- Reattaching the Eyecup
  4. Put the EYECUP on the VIEWFINDER.
  5. Refit the screws.

### Cleaning the Video Heads

To ensure normal recording and clear pictures, clean the video heads when the playback pictures display square block-shape picture noise or only the blue screen appears during playback, as the video heads may be dirty.

1. Set the power switch to PLAYER mode.
2. Insert the cleaning tape.
3. Press the ►/II (PLAY/STILL) button.
4. Press the ■ (STOP) button after 10 seconds.

### Notes

- Check the quality of the picture using a video cassette. If it is still bad, repeat the operation. If the problem continues, contact your local authorized service center.
- Clean the video heads with the dry type cassette cleaner.

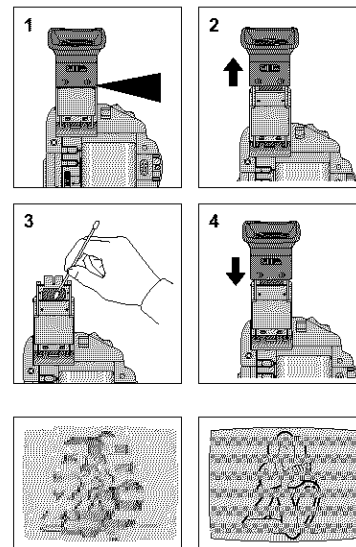

# Using Your Camcorder Abroad

---

- ❖ Each country or area has its own electric and TV color system.
- ❖ Before using your camcorder abroad, check the following points.

## Power sources

- You can use your camcorder in any country or area with the supplied AC Power Adapter within 100V to 240V, 50/60 Hz.
- Use a commercially available AC plug Adapter, if necessary, depending on the design of the local wall outlet.

## Color system

- You can view your recording in the viewfinder.  
However, to view it on a television or copy it to a video cassette recorder, the television or VCR must be NTSC-compatible and have the appropriate audio/video jacks.  
Otherwise, you may need to use a transcoder.

### • PAL-compatible area

Australia, Austria, Belgium, Bulgaria, China, CIS, Czech Republic, Denmark, Egypt, Finland, France, Germany, Greece, Great Britain, Holland, Hong Kong, Hungary, India, Iran, Iraq, Kuwait, Libya, Malaysia, Mauritius, Norway, Rumania, Saudi Arabia, Singapore, Slovak Republic, Spain, Sweden, Switzerland, Syria, Thailand, Tunisia, etc.

### • NTSC-compatible area

Bahamas, Canada, Central America, Japan, Mexico, Philippines, Korea, Taiwan, United States of America, etc.

#### Note



..... You can make recordings with your camcorder anywhere in the world and you can watch the playback picture on the LCD screen.

# Troubleshooting

## Troubleshooting

- ❖ Before contacting a service center, perform the following simple checks. They may save you the time and expense of an unnecessary call.

### Self Diagnosis Display

Display	Blinking	Informs that...	Action
	slow	the battery pack is almost discharged.	Change to a charged one.
	fast	the battery pack is fully discharged.	Change to a charged battery.
 2MIN	slow	When the remaining time of the tape is about 3 minutes.	Prepare a new one.
TAPE END	no	the tape reached its end.	Change to a new one.
TAPE	slow	there is no tape in camcorder.	Insert a tape.
TAPE	slow	the tape is protected to record.	If you want to record, release the protection.
C.EMG D.EMG L.EMG R.EMG	slow	the camcorder has some mechanical fault.	1. Eject the tape. 2. Set to OFF. 3. Detach the battery. 4. Reattach the battery. * If unresolved contact your local service representative.
DEW	slow	moisture condensation has formed in the camcorder.	see below.

### Moisture Condensation

- ❖ If the camcorder is brought directly from a cold place to a warm place, moisture may condense inside the camcorder, on the surface of the tape, or on the lens. In this condition, the tape may stick to the head drum and be damaged or the unit may not operate correctly. To prevent possible damage under these circumstances, the camcorder is fitted with a moisture sensor.
- ❖ If there is moisture inside the camcorder, "DEW" is displayed. If this happens, none of the functions except cassette ejection will work. Open the cassette compartment and remove the battery. Leave the camcorder for at least two hours in a dry warm room.

# Troubleshooting

❖ If these instructions do not allow you to solve the problem, contact your nearest authorized service center.

Symptom	Explanation/Solution
You cannot switch the camcorder on.	Check the battery pack or the AC Power Adapter.
START/STOP button does not operate while recording.	Check the POWER switch is set to CAMERA. You have reached the end of the cassette. Check the record protection tab on the cassette.
The camcorder goes off automatically.	You have left the camcorder set to STBY for more than 5 minutes without using it. The battery pack is fully exhausted.
The battery pack is quickly exhausted.	The atmospheric temperature is too low. The battery pack has not been fully charged. The battery pack is completely dead, and cannot be recharged, Use another battery pack.
When you see a blue screen during playback.	The video heads may be dirty. Clean the head with a cleaning tape.
A vertical strip appears on the screen when recording a dark background.	The contrast between the subject and the background is too great for the camcorder to operate normally. Make the background brighter to reduce the contrast or use the BLC function while you are recording.
The image in the viewfinder is blurred.	The Viewfinder lens has not been adjusted. Adjust the viewfinder control lever until the indicators displayed on the viewfinder come into sharp focus.
Auto focus does not work.	Check the M.FOCUS menu. Auto focus does not work in the Manual Focus mode.
Play, FF or REW button do not work.	Check the POWER switch. Set the power switch to PLAYER. You have reached the beginning or end of the cassette.
When you see a broken block image during EDIT SEARCH.	This is normal and it is not a failure or defect.

ENGLISH

# Specifications

**Model name: SCD67/SCD70**

System	
Video signal	NTSC standards
Video recording system	2 rotary heads, Helical scanning system
Audio recording system	Rotary heads, PCM system
Usable cassette	Digital video tape (6.35mm width): Mini DV cassette
Tape speed	SP: approx. 18.81mm/s LP: approx. 12.56mm/s
Tape recording time	SP: 60 minutes (when using DVM 60) LP: 90 minutes (when using DVM 60)
FF/REW time	Approx. 150 sec. (using DVM60 tape)
Image device	CCD (Charge Coupled Device)
Lens	F1.6 22x(Optical), 500x(Digital) Electronic zoom lens
Filter diameter	Ø37
LCD monitor/Viewfinder	
Size/dot number	2.5inch/112,320
LCD monitor Method	TFT LCD
Viewfinder	0.24" B/W LCD
Connectors	
Video output	1Vp-p (75Ω terminated)
S-video output	Y: 1Vp-p, 75Ω, C: 0.286Vp-p, 75Ω
Audio output	-7.5dBs (600Ω terminated)
DV input/output	4pin special in/out connector
External mic	Ø3.5 stereo

# Specifications

---

General	
Power source	DC 8.4 V, Lithium Ion Battery Pack 7.4 V
Power source type	Lithium Ion Battery Pack, Power supply (100 V~240 V) 50/60 Hz
Power consumption (Recording)	6.3 W (LCD), 5.0 W (EVF)
Storage temperature	Operating temperature 0°~40°C (32°F~104°F)
External dimension	-20°C ~ 60°C (-4°F ~ 140°F)
Weight	Length 158 mm (6.22 in.), Height 93 mm (3.66 in.), Width 87 mm (3.43 in.)
Built-in MIC	580 g (1.28 lb) (Except for Lithium Ion Battery Pack and tape)
Remote control	Omni-directional stereo condenser microphone
	Indoors: greater than 49 ft (straight line)
	Outdoors: greater than 16 ft (straight line)

- These technical specifications and design may be changed without notice.

**ENGLISH**

**INDEX**

- A -			
ART .....	40	NEGA .....	40
AF .....	54	ND FILTER .....	60
- B -		NTSC .....	71
BATTERY PACK .....	22	- P -	
B/W .....	40	PAL .....	71
- C -		PHOTO .....	58
Charge .....	22	PIP .....	36
Cleaning .....	70	PLAY .....	64
CUSTOM .....	53	POWER ADAPTER .....	21
- D -		PROGRAM AE .....	39
DATE/TIME .....	49	- R -	
Digital Zoom .....	38	REC LAMP .....	46
DIS .....	36	REC MODE .....	45
DSE .....	40	REMOTE CONTROL .....	18
DUBBING .....	57	- S -	
DV in/out .....	67	SAFETY TAB (red tab) .....	25
- E -		SELF TIMER .....	18
EASY .....	52	SHUTTER SPEED .....	43
EDIT SEARCH .....	27	STBY .....	26
- F -		SOUND 1 .....	58
FADE .....	56	SOUND 2 .....	58
F.ADV .....	65	S-VIDEO .....	62
F.F./REW .....	64	- T -	
- I -		TELE .....	37
IEEE 1394 .....	67	- V -	
IRIS .....	44	VIEWFINDER .....	29
- M -		- W -	
MF .....	54	WIDE .....	37
MIRROR .....	40	WHITE BALANCE .....	42
MIX .....	58	- Z -	
MOSAIC .....	40	ZERO MEMORY .....	66
		ZOOM .....	37



# Warranty

---

## SAMSUNG LIMITED WARRANTY

SAMSUNG Electronics America Inc. (SEA), warrants that this product is free from defective material and workmanship.

SEA further warrants that if product fails to operate properly within the specified warranty period and the failure is due to improper workmanship or defective material, SEA will repair or replace the product at its option.

All warranty repairs must be performed by a SEA authorized service center. The name and address of the location nearest you can be obtained by calling toll free: 1-800 SAMSUNG (1-800-726-7864).

Labor

90 days carry-in

Parts

1 year

On carry-in models, transportation to and from the service center is the customer's responsibility.

The original dated sales receipt must be retained by the customer and is the only acceptable proof of purchase. It must be presented to the authorized service center.

### EXCLUSIONS (WHAT IS NOT COVERED)

This warranty does not cover damage due to accident, fire, flood and/or other acts of God; misuse, incorrect line voltage, improper installation, improper or unauthorized repairs, commercial use, or damage that occurs in shipping.

Exterior and interior finish, lamps, and glass are not covered under this warranty.

Customer adjustments which are explained in the instruction manual are not covered under the terms of this warranty. This warranty will automatically be voided for any unit found with a missing or altered serial number. This warranty is valid only on products purchased in the United States and Puerto Rico.

Some States do not allow the exclusions or limitations of incidental or consequential damages, or allow limitations on how long an implied warranty lasts, so the above limitations or exclusions may not apply to you. This warranty gives you specific legal rights, and you may also have other rights which vary from State to State.

**ENGLISH**

**THIS CAMCORDER IS MANUFACTURED BY:**

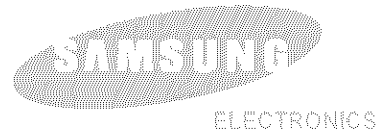

**SAMSUNG Electronics America Inc.**  
**105 Challenger Road, Ridgefield Park N.J 07660-0511**  
**Tel: 1-800-SAMSUNG**  
**(1-800-726-7864)**

**\*Samsung Electronics' Internet Home Page**  
**<http://www.samsungusa.com>**

**AD68-00395H**