

Installation and Start-Up Instructions

NOTE: Read the entire instruction manual before starting the installation.

This symbol → indicates a change since the last issue.

SAFETY CONSIDERATIONS

Improper installation, adjustment, alteration, service, maintenance, or use can cause explosion, fire, electrical shock, or other conditions which may cause death, personal injury, or property damage. Consult a qualified installer, service agency, or your distributor or branch for information or assistance. The qualified installer or agency must use factory-authorized kits or accessories when modifying this product. Refer to the individual instructions packaged with the kits or accessories when installing.

Follow all safety codes. Wear safety glasses, protective clothing, and work gloves. Use quenching cloth for brazing operations. Have fire extinguisher available. Read these instructions thoroughly and follow all warnings or cautions included in literature and attached to the unit. Consult local building codes and National Electrical Code (NEC) for special requirements.

Recognize safety information. This is the safety-alert symbol . When you see this symbol on the unit and in instructions or manuals, be alert to the potential for personal injury.

Understand the signal words DANGER, WARNING, and CAUTION. These words are used with the safety-alert symbol. DANGER identifies the most serious hazards which **will** result in severe personal injury or death. WARNING signifies hazards which **could** result in personal injury or death. CAUTION is used to identify unsafe practices which **would** result in minor personal injury or product and property damage. NOTE is used to highlight suggestions that **will** result in enhanced installation, reliability, or operation.

WARNING

Before installing, modifying, or servicing system, main electrical disconnect switch must be in the OFF position. There may be more than 1 disconnect switch. Lock out and tag switch with a suitable warning label. Electrical shock can cause personal injury or death.

INSTALLATION RECOMMENDATIONS

NOTE: In some cases noise in the living area has been traced to gas pulsations from improper installation of equipment.

1. Locate unit away from windows, patios, decks, etc. where unit operation sounds may disturb customer.
2. Ensure that vapor and liquid tube diameters are appropriate to capacity¹ of unit.
3. Run refrigerant tubes as directly as possible by avoiding unnecessary turns and bends.
4. Leave some slack between structure and unit to absorb vibration.
5. When passing refrigerant tubes through the wall, seal opening with RTV or other pliable silicon-based caulk. (See Fig. 2.)

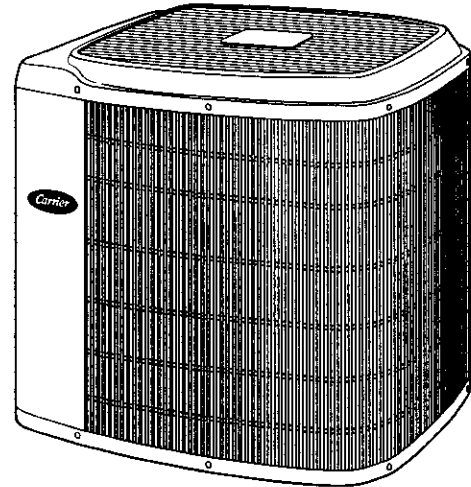

A98516

Fig. 1—Model 38YRA

6. Avoid direct tubing contact with water pipes, duct work, floor joists, wall studs, floors, and walls.
7. Do not suspend refrigerant tubing from joists and studs with a rigid wire or strap which comes in direct contact with tubing. (See Fig. 2.)
8. Ensure that tubing insulation is pliable and completely surrounds vapor tube.
9. When necessary, use hanger straps which are 1 in. wide and conform to shape of tubing insulation. (See Fig. 2.)
10. Isolate hanger straps from insulation by using metal sleeves bent to conform to shape of insulation.

When outdoor unit is connected to factory-approved indoor unit, outdoor unit contains system refrigerant charge for operation with indoor unit of the same size when connected by 15 ft of field-supplied or factory accessory tubing. For proper unit operation, check refrigerant charge using charging information located on control box cover.

IMPORTANT: Maximum liquid-line size is 3/8-in. O.D. for all residential applications including long line.

IMPORTANT: Always install a liquid-line filter drier. Refer to Product Data Digest for appropriate part number. Obtain filter drier from service parts or your distributor or branch.

INSTALLATION

Step 1—Check Equipment and Job Site

UNPACK UNIT

Move to final location. Remove carton taking care not to damage unit.

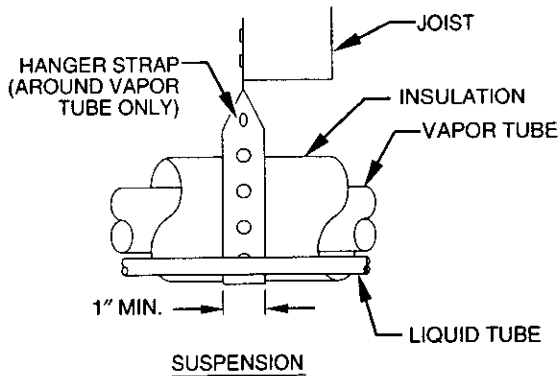
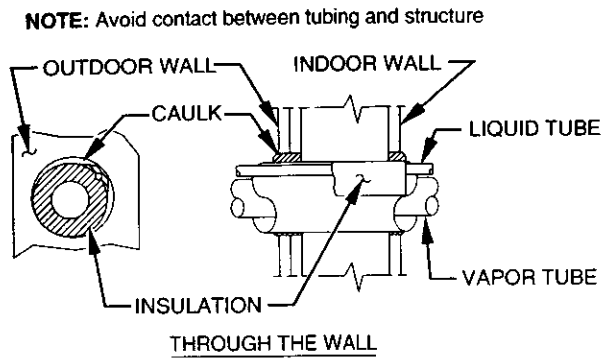

Fig. 2—Connecting Tubing Installation

A94028

INSPECT EQUIPMENT

File claim with shipping company prior to installation if shipment is damaged or incomplete. Locate unit rating plate on unit corner panel. It contains information needed to properly install unit. Check rating plate to be sure unit matches job specifications.

Step 2—Install on a Solid, Level Mounting Pad

If conditions or local codes require the unit be attached to pad, tie down bolts should be used and fastened through knockouts provided in unit base pan. Refer to unit mounting pattern in Fig. 3 to determine base pan size and knockout hole location.

On rooftop applications, mount on level platform or frame 6 in. above roof surface. Place unit above a load-bearing wall and isolate unit and tubing set from structure. Arrange supporting members to adequately support unit and minimize transmission of vibration to building. Consult local codes governing rooftop applications.

Roof mounted units exposed to winds above 5 mph may require wind baffles to achieve adequate defrost. Consult Low-Ambient Guideline for wind baffle construction.

NOTE: Unit must be level to within $\pm 2^\circ$ ($\pm 3/8$ in./ft) per compressor manufacturer specifications.

Step 3—Clearance Requirements

When installing, allow sufficient space for airflow clearance, wiring, refrigerant piping, and service. Allow 30-in. clearance to service end of unit and 48 in. above unit. For proper airflow, a 6-in. clearance on 1 side of unit and 12 in. on all remaining sides must be maintained. Maintain a distance of 24 in. between units. Position so water, snow, or ice from roof or eaves cannot fall directly on unit.

On rooftop applications, locate unit at least 6 in. above roof surface.

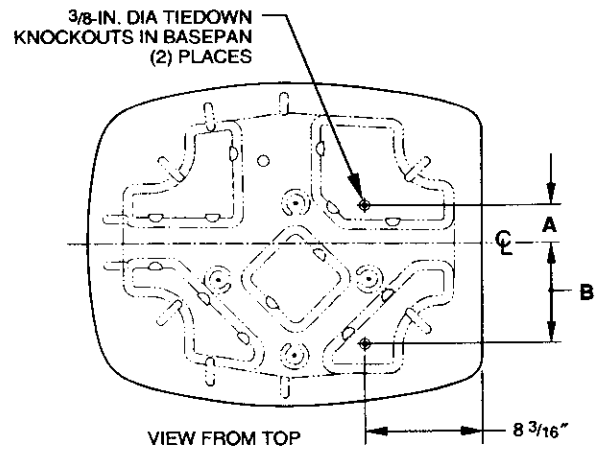

A97548

Dimensions (In.)

UNIT SIZE	MINIMUM MOUNTING PAD DIMENSIONS		TIEDOWN KNOCKOUT LOCATIONS	
	Support Feet	Snow Stand	A	B
018-048	26 X 32	31 X 35	5-1/16	9-11/16
060	32 X 42	36 X 46	7-1/8	12-1/8

Fig. 3—Mounting Unit to Pad

Step 4—Operating Ambients

The minimum outdoor operating ambient in cooling mode is 55°F, and the maximum outdoor operating ambient in cooling mode is 125°F. The maximum outdoor operating ambient in heating mode is 66°F.

Step 5—Elevate Unit

CAUTION

Accumulation of water and ice in base pan may cause equipment damage.

Elevate unit per local climate and code requirements to provide clearance above estimated snowfall level and ensure adequate drainage of unit. Fig. 4 shows unit with accessory support feet installed. Use accessory snow stand in areas where prolonged freezing temperatures are encountered. Refer to separate Installation Instructions packaged with accessories.

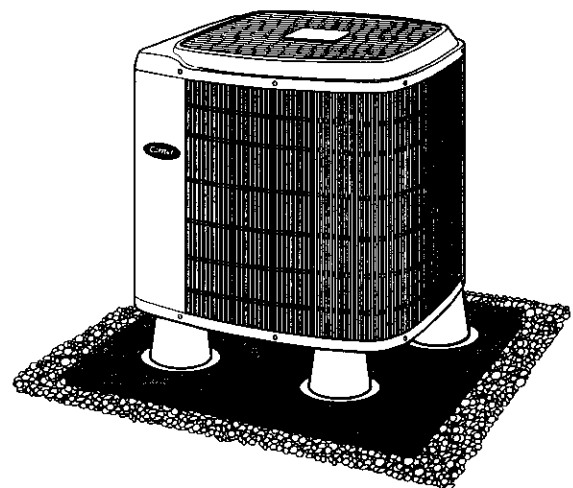

Fig. 4—Accessory Support Feet

A98533

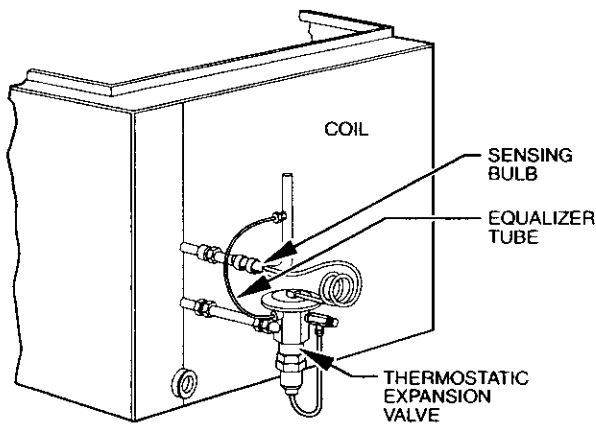

Fig. 5—Typical TXV Installation

A88382

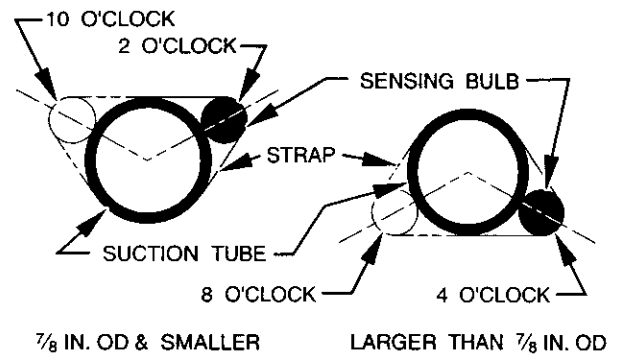

Fig. 6—Positioning of Sensing Bulb

A81032

Step 6—Remove Indoor AccuRater® Piston and Install TXV

⚠ CAUTION

For proper unit operation and reliability, units must be installed with field-supplied hard shutoff TXV. Do not install with evaporator coils having capillary tube metering devices or pistons.

For TXV kit part number and charging instructions, refer to TXV label in outdoor unit.

FURNACE COILS

If TXV installation is required, remove existing AccuRater from indoor coil. Refer to Fig. 5 and 6 and install TXV kit as follows:

1. Install suction tube adapter.
2. Install liquid flare-to-sweat adapter.
3. Connect external equalizer tube to fitting on suction tube adapter.
4. Position sensing bulb on horizontal portion of suction tube adapter. Secure using supplied hardware.
5. Insulate bulb after installation. (See Fig. 6.)
6. Leak check all connections.

FAN COILS

If indoor unit (fan coil) comes factory equipped with a bi-flow hard shutoff TXV, no TXV change is required.

Refer to TXV kit Installation Instructions for details on TXV installation.

Step 7—Check Outdoor AccuRater® Piston

Check outdoor unit piston. Remove retainer on liquid service valve and check piston size with matching number listed on outdoor unit rating plate.

Step 8—Check Defrost Thermostat

Check defrost thermostat to ensure it is properly located and securely attached. There is a liquid header with a brass distributor and feeder tube going into outdoor coil. At the end of 1 of the feeder tubes, there is a 3/8-in. O.D. stub tube approximately 3 in. long. (See Fig. 7.) The defrost thermostat should be located on stub tube. Note that there is only 1 stub tube used with liquid header, and on most units it is the bottom circuit.

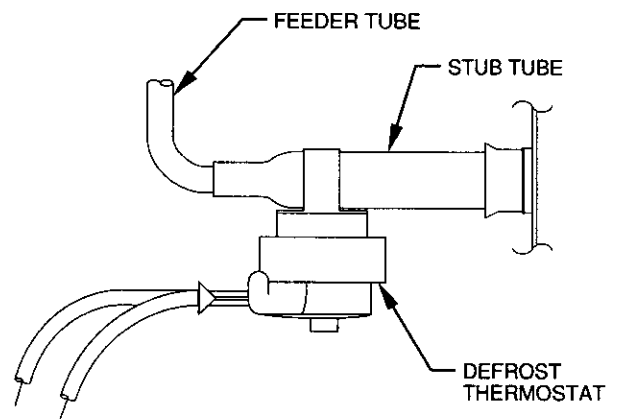

Fig. 7—Defrost Thermostat Location

A97517

Step 9—Install Liquid-Line Solenoid Valve (LSV)—Optional

Heating efficiency (HSPF) can be improved by the addition of a LSV. Refer to presale literature for rating enhancement. Install LSV per Installation Instructions included with accessory kit.

NOTE: To enhance heating HSPF, flow arrow must point toward outdoor coil.

Step 10—Make Piping Connections

⚠ WARNING

Relieve pressure and recover all refrigerant before system repair or final unit disposal to avoid personal injury or death. Use all service ports and open all flow-control devices, including solenoid valves.

⚠ CAUTION

If ANY refrigerant tubing is buried, provide a 6 in. vertical rise at service valve. Refrigerant tubing lengths up to 36 in. may be buried without further special consideration. For lengths above 36 in., consult your local distributor.

Table 1—Refrigerant Connections and Recommended Liquid and Vapor Tube Diameters (In.)

UNIT SIZE	LIQUID		VAPOR		VAPOR (LONG LINE)	
	Connection Diameter	Tube Diameter	Connection Diameter	Tube Diameter	Connection Diameter	Tube Diameter
018	3/8	3/8	5/8	5/8	5/8	3/4
024	3/8	3/8	3/4	3/4	3/4	3/4
030	3/8	3/8	3/4	3/4	3/4	7/8
036	3/8	3/8	7/8	7/8	7/8	7/8
042, 048	3/8	3/8	7/8	7/8	7/8	1-1/8
060	3/8	3/8	7/8	1-1/8	7/8	1-1/8

NOTES:

1. Tube diameters are for lengths up to 50 ft. For tubing lengths greater than 50 ft, consult Residential Split System Long-Line Application Guideline.
2. Do not apply capillary tube indoor coils to these units.

⚠ CAUTION

To prevent damage to unit or service valves observe the following:

- Use a brazing shield.
- Wrap service valves with wet cloth or use a heat sink material.

Outdoor units may be connected to indoor section using accessory tubing package or field-supplied refrigerant grade tubing of correct size and condition. For tubing requirements beyond 50 ft, substantial capacity and performance losses can occur. Following the recommendations in the Residential Split System Long-Line Application Guideline will reduce these losses. Refer to Table 1 for field tubing equivalent line length. Refer to Table 2 for accessory requirements.

For buried-line applications greater than 36 in., consult your local distributor.

If refrigerant tubes or indoor coil are exposed to atmosphere, they must be evacuated to 500 microns to eliminate contamination and moisture in the system.

OUTDOOR UNIT CONNECTED TO FACTORY-APPROVED INDOOR UNIT

Outdoor unit contains correct system refrigerant charge for operation with indoor unit of same size when connected by 15 ft of field-supplied or factory-accessory tubing. Check refrigerant charge for maximum efficiency.

REFRIGERANT TUBING

Connect tubing to fittings on outdoor unit vapor and liquid service valves. (See Table 1.) Use refrigerant grade tubing.

SWEAT CONNECTION

⚠ CAUTION

To avoid valve damage while brazing, service valves must be wrapped in a heat-sinking material such as a wet cloth.

Remove plastic retainer holding outdoor piston in liquid service valve and connect sweat/flare adapter provided to valve. (See Fig. 8.) Connect refrigerant tubing to fittings on outdoor unit vapor and liquid service valves. Service valves are closed from factory and ready for brazing. After wrapping service valve with a wet cloth, tubing set can be brazed to service valve using either silver bearing or non-silver bearing brazing material. Consult local code requirements. Refrigerant tubing and indoor coil are now ready for leak testing. This check should include all field and factory joints.

IMPORTANT: Check to be certain factory tubing on both indoor and outdoor unit has not shifted during shipment. Ensure tubes are not rubbing against each other or any sheet metal. Pay close attention to feeder tubes, making sure wire ties on feeder tubes are secure and tight.

Table 2—Accessory Usage

ACCESSORY	REQUIRED FOR LOW-AMBIENT APPLICATIONS (BELOW 55°F)	REQUIRED FOR LONG-LINE APPLICATIONS* (OVER 50 FT)
Crankcase Heater	Yes	Yes
Evaporator Freeze Thermostat	Yes	No
Accumulator	No	No
Compressor Start Assist Capacitor and Relay	Yes	Yes
MotorMaster® Control, or Low-Ambient Pressure Switch	Yes	No
Wind Baffle	See Low-Ambient Instructions	No
Support Feet	Recommended	No
Liquid-Line Solenoid Valve or Hard Shutoff TXV	No	See Long-Line Application Guideline
Ball Bearing Fan Motor	Yes‡	No

* For tubing line sets between 50 and 175 ft, refer to Residential Split System Long-Line Application Guideline.

‡ Required for Low-Ambient Controller (full modulation feature) and MotorMaster Control only.

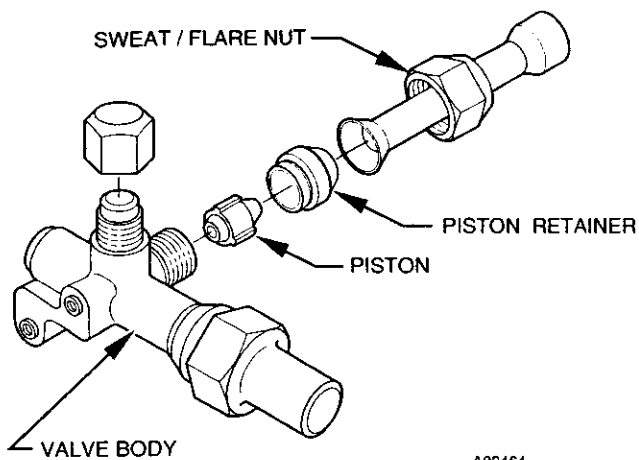

A92464

A92464

Fig. 8—Liquid Service Valve with Sweat Adapter Tube

Step 11—Make Electrical Connections

⚠ WARNING

To avoid personal injury or death, do not supply power to unit with compressor terminal box cover removed.

Be sure field wiring complies with local and national fire, safety, and electrical codes, and voltage to system is within limits shown on unit rating plate. Contact local power company for correction of improper voltage. See unit rating plate for recommended circuit protection device.

NOTE: Operation of unit on improper line voltage constitutes abuse and could affect unit reliability. See unit rating plate. Do not install unit in system where voltage may fluctuate above or below permissible limits.

NOTE: Use copper wire only between disconnect switch and unit.

NOTE: Install branch circuit disconnect of adequate size per NEC to handle unit starting current. Locate disconnect within sight from and readily accessible from unit, per Section 440-14 of NEC.

ROUTE GROUND AND POWER WIRES

Remove access panel and control box cover to gain access to unit wiring. Extend wires from disconnect through power wiring hole provided and into unit control box.

⚠ WARNING

The unit cabinet must have an uninterrupted or unbroken ground to minimize personal injury if an electrical fault should occur. The ground may consist of electrical wire or metal conduit when installed in accordance with existing electrical codes. Failure to follow this warning can result in an electric shock, fire, or death.

CONNECT GROUND AND POWER WIRES

Connect ground wire to ground connection in control box for safety. Connect power wiring to contactor as shown in Fig. 9.

CONNECT CONTROL WIRING

Route 24-v control wires through control wiring grommet and connect leads to control wiring. (See Fig. 10–14.)

Use No. 18 AWG color-coded, insulated (35°C minimum) wire. If thermostat is located more than 100 ft from unit, as measured along the control voltage wires, use No. 16 AWG color-coded wire to avoid excessive voltage drop.

DISCONNECT
PER N. E. C. AND/OR
LOCAL CODES

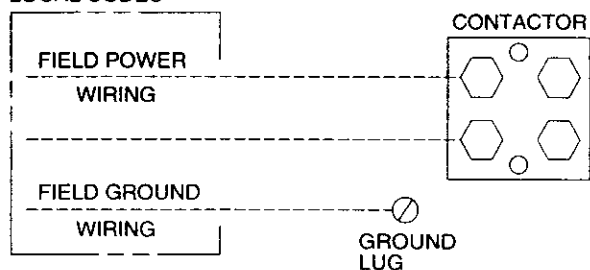

A91056

Fig. 9—Line Power Connections

All wiring must be NEC Class 1 and must be separated from incoming power leads.

Use furnace transformer, fan coil transformer, or accessory transformer for control power. 24-v/40-va minimum.

NOTE: Use of available 24-v accessories may exceed the minimum 40-va power requirement. Determine total transformer loading and increase the transformer capacity or split the load with an accessory transformer as required.

IMPORTANT: Check factory wiring and wire connections to ensure terminations are secured properly. Check wire routing to ensure wires are not in contact with tubing, sheet metal, etc.

Step 12—Compressor Crankcase Heater

When equipped with a crankcase heater, furnish power to heater a minimum of 24 hr before starting unit. To furnish power to heater only, set thermostat to OFF and close electrical disconnect to outdoor unit.

A crankcase heater is required if refrigerant tubing is longer than 50 ft.

Step 13—Install Electrical Accessories

Refer to the individual instructions packaged with kits or accessories when installing.

Step 14—Start-Up

⚠ CAUTION

To prevent compressor damage or personal injury, observe the following:

- Do not overcharge system with refrigerant.
 - Do not operate unit in a vacuum or at negative pressure.
 - Do not disable low-pressure switch.
- In scroll compressor applications:
- Dome temperatures may be hot.

⚠ CAUTION

To prevent personal injury wear safety glasses, protective clothing, and gloves when handling refrigerant and observe the following:

- Back seating service valves are not equipped with Schrader valves. Fully back seat (counter clockwise) valve stem before removing gage port cap.
- Front seating service valves are equipped with Schrader valves.

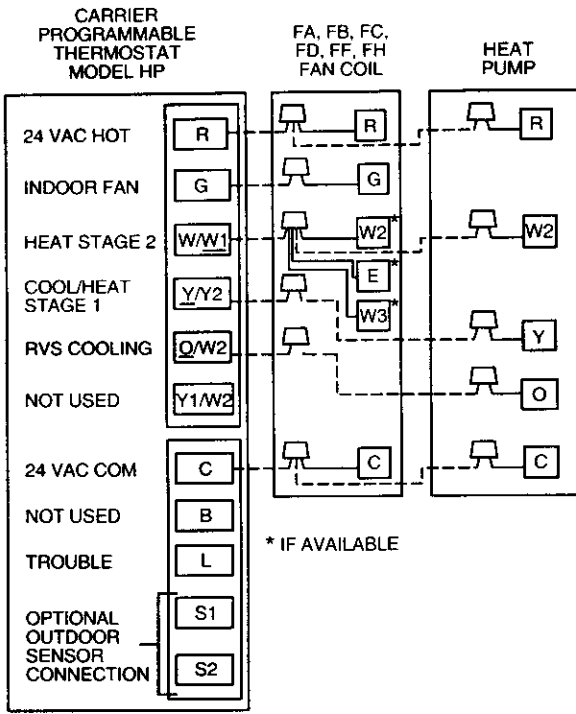

A97534

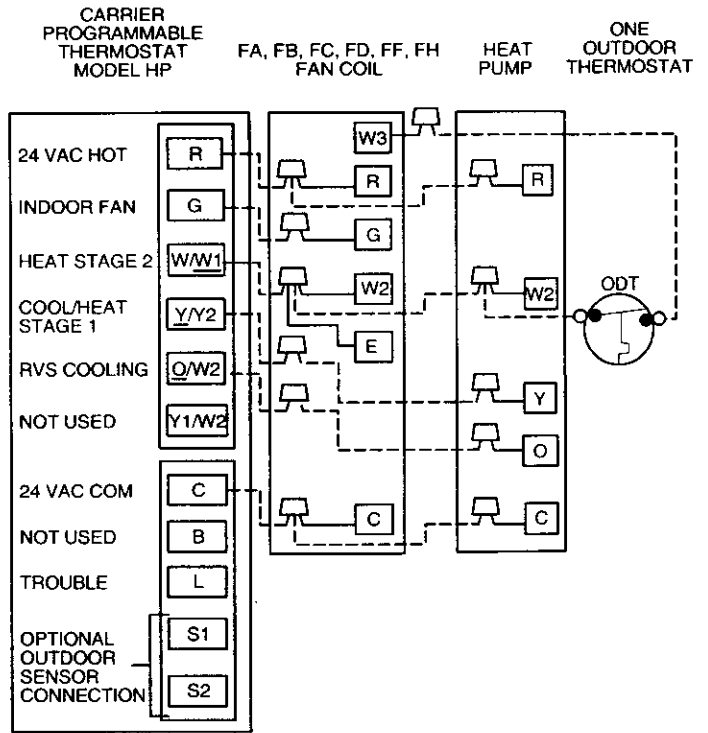

NOTE: Remove wires from crimp nut in indoor fan coil when installing outdoor thermostat.

IMPORTANT: When using outdoor thermostat, W₂ must be energized when requesting supplemental heat.

A97535

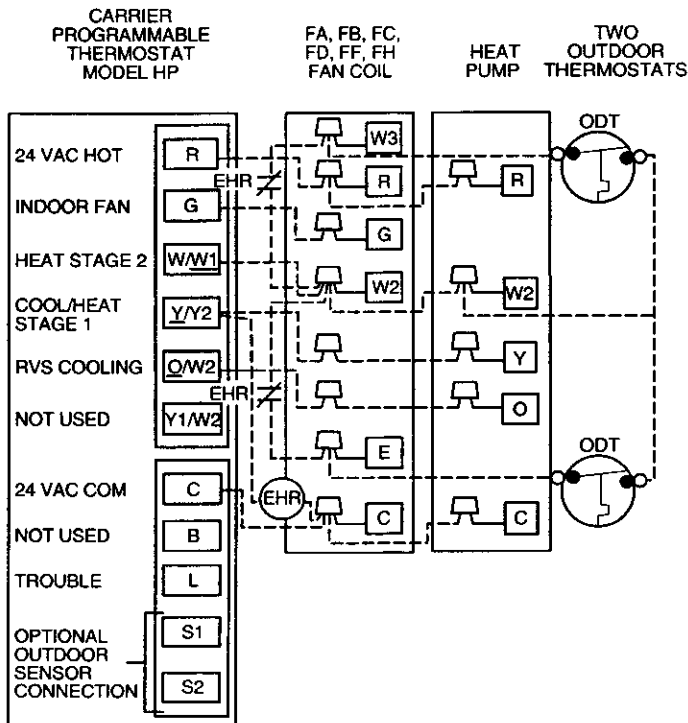

NOTE: Remove wires from crimp nut in indoor fan coil when installing outdoor thermostats.

IMPORTANT: When using outdoor thermostats, W₂ must be energized when requesting supplemental heat.

A97536

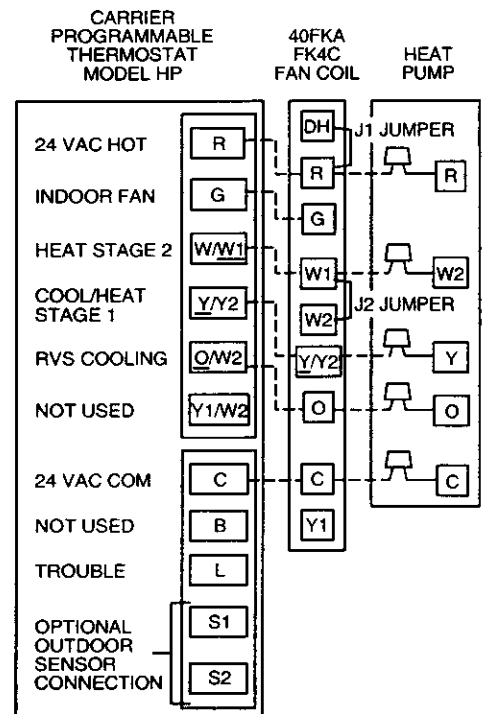

A98629

Fig. 10—Typical 24-v Circuit Connections using Carrier Model HP Thermostat with Fan Coils and No Outdoor Thermostat, 1 Outdoor Thermostat, or 2 Outdoor Thermostats

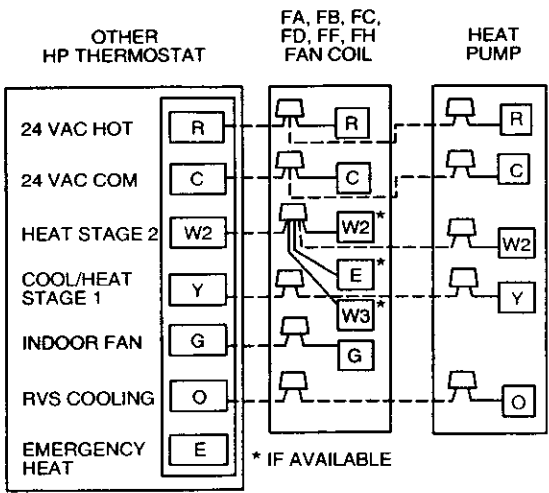

A97374

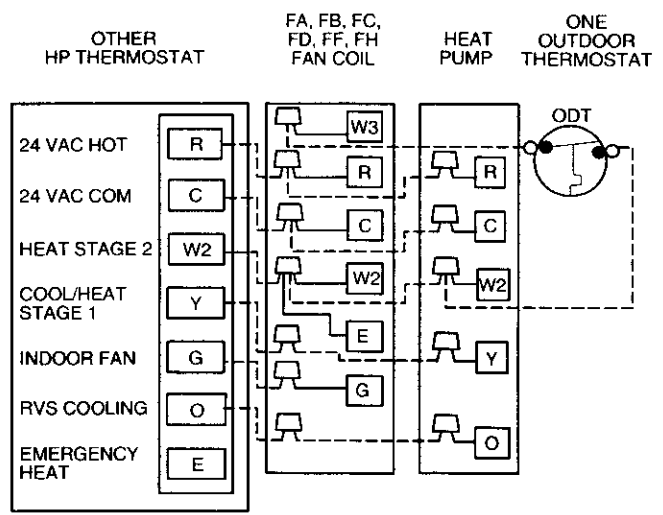

NOTE: Remove wires from crimp nut in indoor fan coil when installing outdoor thermostat.

IMPORTANT: When using outdoor thermostat, W₂ must be energized when requesting supplemental heat.

A97403

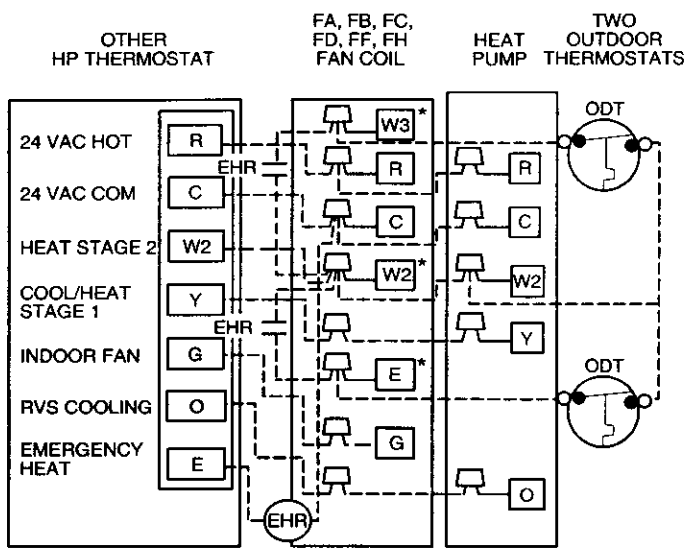

* IF AVAILABLE

NOTE: Remove wires from crimp nut in indoor fan coil when installing outdoor thermostats.

IMPORTANT: When using outdoor thermostats, W₂ must be energized when requesting supplemental heat.

A97404

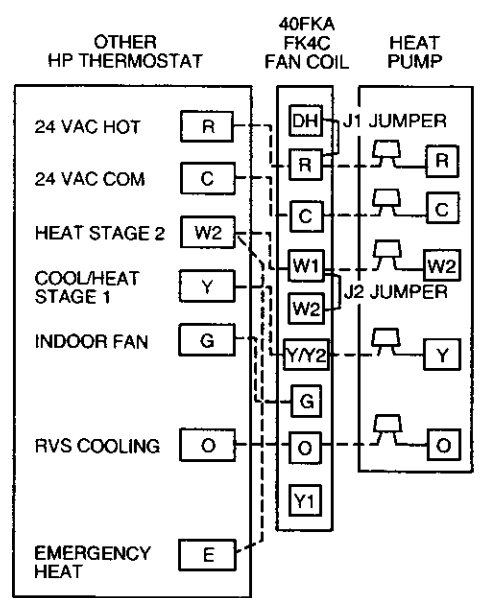

A98630

Fig. 11—Typical 24-v Circuit Connections using Other HP Thermostats with Fan Coils and No Outdoor Thermostat, 1 Outdoor Thermostat, or 2 Outdoor Thermostats

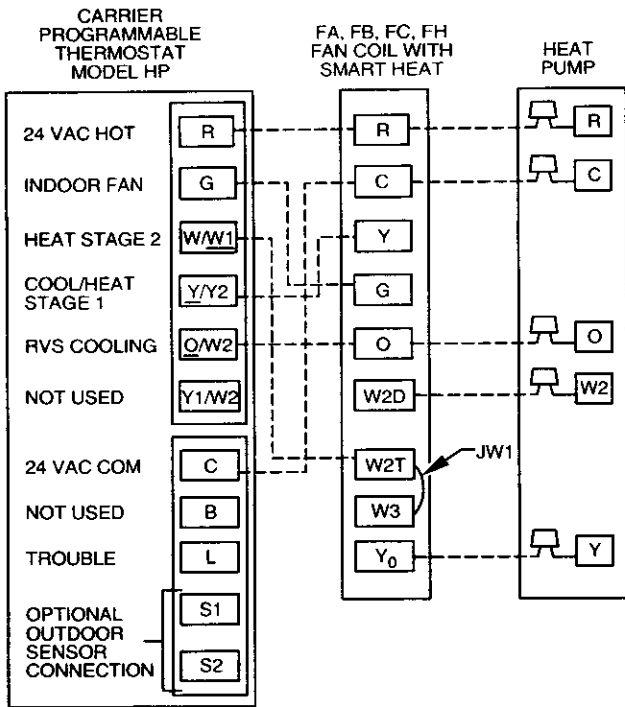

A97541

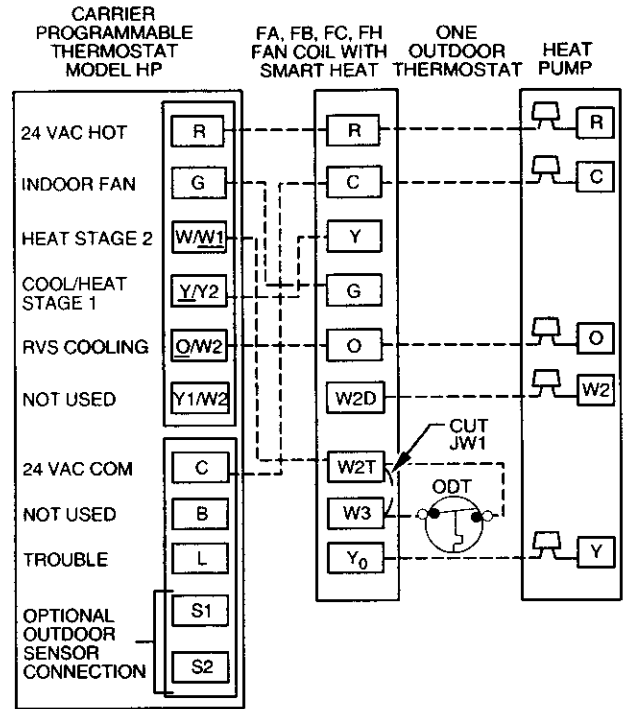

A97542

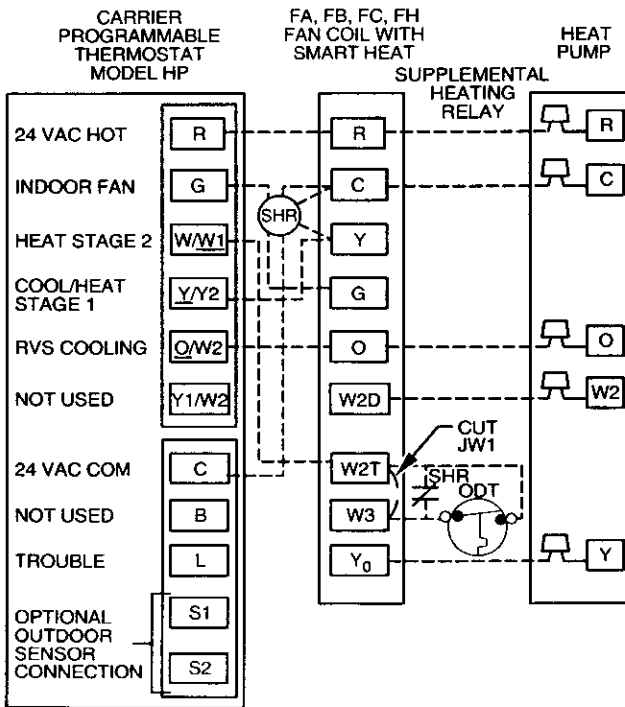

A97543

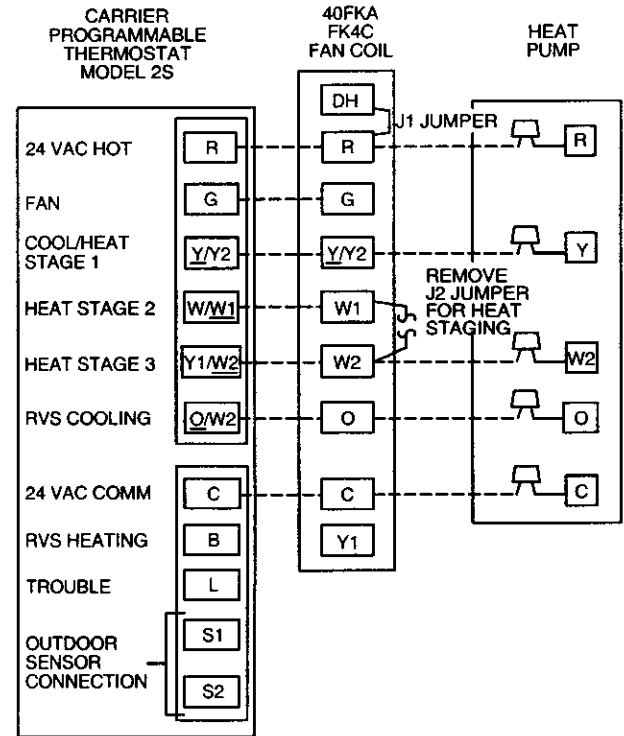

A98631

Fig. 12—Typical 24-v Circuit Connections using Carrier Model HP Thermostat with Smart Heat and No Outdoor Thermostat, 1 Outdoor Thermostat, or 2 Outdoor Thermostats and Carrier Model 2S Thermostat with FK4C/40FKA Fan Coil and Intelligent Staging

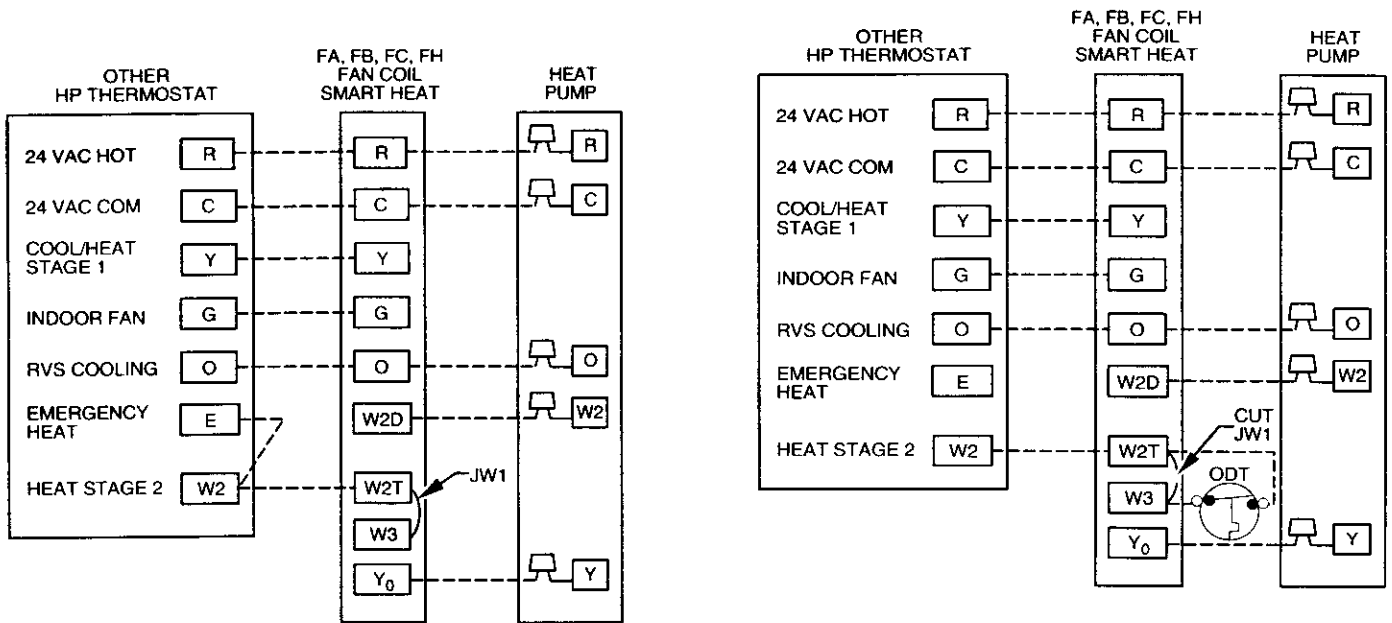

A97411

A97410

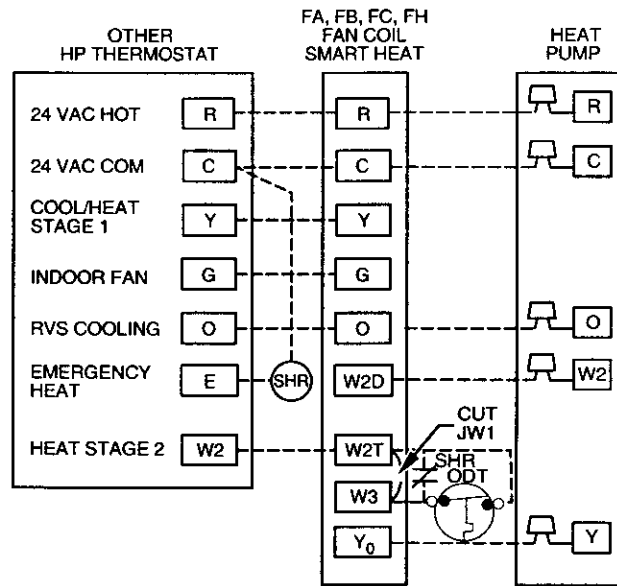

A97412

Fig. 13—Typical 24-v Circuit Connections using Other HP Thermostats with Smart Heat and No Outdoor Thermostat, 1 Outdoor Thermostat, or 2 Outdoor Thermostats

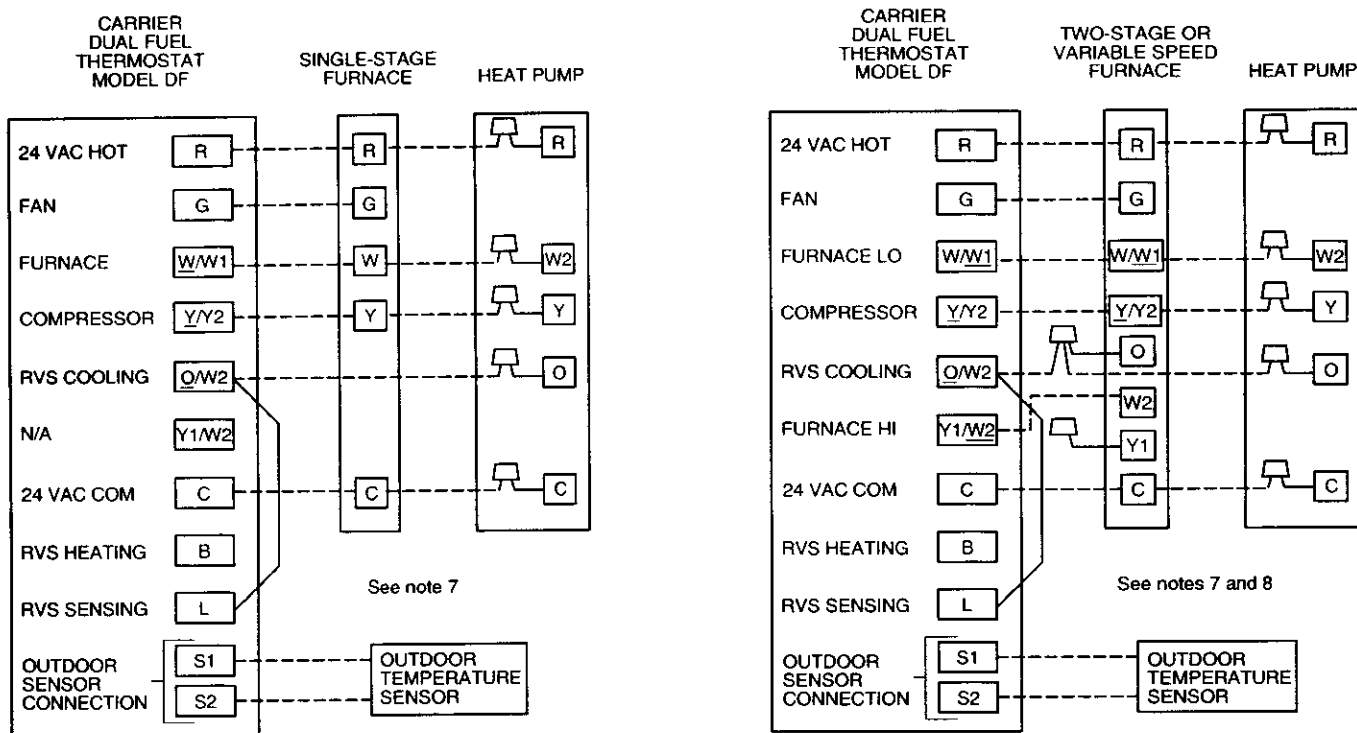

A97538

A97539

Fig. 14—Typical 24-v Circuit Connections using Carrier Model DF Thermostat with Single- or 2-Stage Furnace

WIRING DIAGRAM NOTES:

1. CARRIER THERMOSTAT WIRING DIAGRAMS ARE ONLY ACCURATE FOR MODEL NUMBERS BEGINNING WITH TSTAT
2. WIRING MUST CONFORM TO NEC OR LOCAL CODES.
3. SOME UNITS ARE EQUIPPED WITH PRESSURE SWITCH(ES), TEMPERATURE SWITCH, OR 5-MINUTE COMPRESSOR CYCLE PROTECTION. CONNECT 24-V FIELD WIRING TO FACTORY-PROVIDED STRIPPED LEADS.
4. A LIQUID-LINE SOLENOID VALVE IS REQUIRED ON SOME UNITS.
5. THERMOSTATS ARE FACTORY CONFIGURED WITH 5-MINUTE COMPRESSOR CYCLE PROTECTION AND 4 CYCLES PER HR LIMIT. SEE THERMOSTAT INSTALLATION INSTRUCTIONS FOR DETAILS.
6. TO STAGE ELECTRIC RESISTANCE HEAT. CONSULT OUTDOOR THERMOSTAT INSTALLATION INSTRUCTIONS.
7. FOR DUAL FUEL THERMOSTATS, UNDERLINED LETTER ON DUAL TERMINAL INDICATES ITS USAGE.
 FOR EXAMPLE: O/W2 MEANS O
 O/W2 MEANS W2
 OUTDOOR TEMPERATURE SENSOR MUST BE ATTACHED IN ALL DUAL FUEL INSTALLATIONS.
 JUMPER WIRE BETWEEN O/W2 AND L THERMOSTAT TERMINALS **MUST** BE PRESENT.
8. Y1 AND O CONNECTIONS TO 2-STAGE FURNACES **MAY NOT EXIST** OR MAY ONLY BE A WIRE RATHER THAN A SCREW TERMINAL.

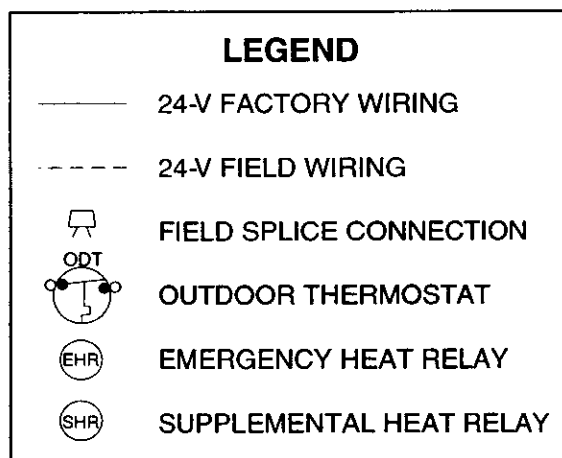

A97413

⚠ CAUTION

Do not vent refrigerant to atmosphere. Recover during system repair or final unit disposal.

Follow these steps to properly pumpdown a system and avoid negative suction pressure.

1. Fully back seat (open) liquid and vapor tube service valves.
2. Unit is shipped with valve stem(s) front seated (closed) and caps installed. Replace stem caps after system is opened to refrigerant flow. Replace caps finger-tight and tighten with wrench an additional 1/12 turn. Use a backup wrench on valve body flats to prevent distortion of sheet metal.
3. Close electrical disconnects to energize system.
4. Set room thermostat to desired temperature. Be sure set point is below indoor ambient temperature.
5. Set room thermostat to HEAT or COOL and fan control to ON or AUTO mode, as desired. Operate unit for 15 minutes. Check system refrigerant charge.

SEQUENCE OF OPERATION

NOTE: Defrost control board is equipped with 5-minute lockout timer which may be initiated upon any interruption of power.

With power supplied to indoor and outdoor units, transformer is energized.

Cooling

On a call for cooling, thermostat makes circuits R-O, R-Y, and R-G. Circuit R-O energizes reversing valve, switching it to cooling position. Circuit R-Y energizes contactor, starting outdoor fan motor and compressor circuit. R-G energizes indoor unit blower relay, starting indoor blower motor on high speed.

When thermostat is satisfied, its contacts open, de-energizing the contactor and blower relay. Compressor and motors should stop.

NOTE: If indoor unit is equipped with a time-delay relay circuit, the blower runs an additional 90 sec to increase system efficiency.

Heating

On a call for heating, thermostat makes circuits R-Y and R-G. Circuit R-Y energizes contactor, starting outdoor fan motor and compressor. Circuit R-G energizes indoor blower relay, starting blower motor on high speed.

Should temperature continue to fall, R-W2 is made through second-stage room thermostat bulb. Circuit R-W2 energizes a sequencer, bringing on first bank of supplemental electric heat and providing electrical potential to second heater sequencer (if used). If outdoor temperature falls below setting of outdoor thermostat (field-installed option), contacts close to complete circuit and bring on second bank of supplemental electric heat.

When thermostat is satisfied, its contacts open, de-energizing contactor and sequencer. All heaters and motors should stop.

→ Quiet Shift

Quiet Shift is a field-selectable defrost mode, which will eliminate occasional noise that could be heard at the start of the defrost cycle and restarting of heating cycle. It is selected by placing DIP switch 3 (on defrost board) in ON position.

When Quiet Shift switch is placed in ON position, and a defrost is initiated, the following sequence of operation will occur. Reversing valve will energize, compressor will turn off for 30 sec, then turn back on to complete defrost. At the start of heating cycle after conclusion of defrost mode, reversing valve will de-energize, the compressor will turn off for another 30 sec, and the fan will turn off for 40 sec, before starting in the heating mode.

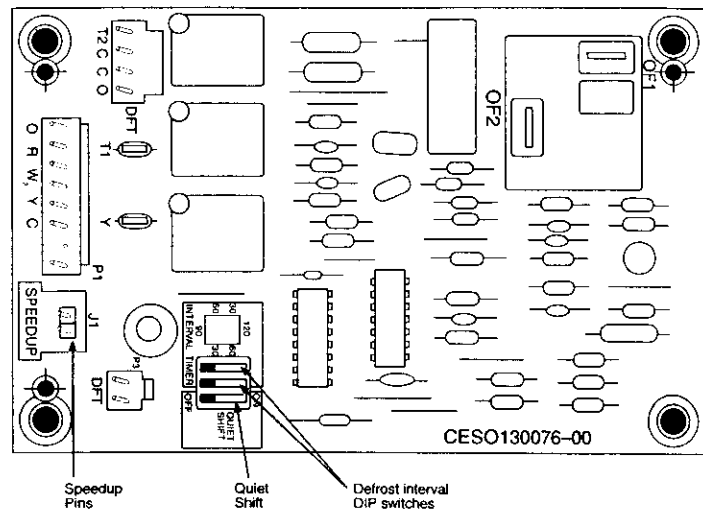

A99442

→ Fig. 15—Defrost Control

→ Defrost

The defrost control is a time/temperature control which includes a field-selectable time period (DIP switch 1 and 2 on the board) between defrost cycles of 30, 60, 90, or 120 minutes (factory set at 90 minutes).

To initiate a forced defrost, two options are available depending on the status of the defrost thermostat.

If defrost thermostat is closed, speedup pins (J1) must be shorted by placing a flat head screwdriver in between for 5 sec and releasing, to observe a complete defrost cycle. When the Quiet Shift switch is selected, compressor will be turned off for two 30 sec intervals during this complete defrost cycle as explained previously. When Quiet Shift switch is in factory default OFF position, a normal and complete defrost cycle will be observed.

If defrost thermostat is in open position, and speedup pins are shorted (with a flat head screwdriver) for 5 sec and released, a short defrost cycle will be observed (actual length is dependent upon the selected Quiet Shift position). When Quiet Shift switch is in ON position, the length of defrost is 1 minute (30 sec compressor off period followed by 30 sec of defrost with compressor operation). On return to heating operation, compressor will again turn off for an additional 30 sec and the fan for 40 sec. When the Quiet Shift is in OFF position, only a brief 30 sec cycle will be observed.

If it is desirable to observe a complete defrost in warmer weather, the thermostat must be closed as follows:

1. Turn off power to outdoor unit.
2. Disconnect outdoor fan motor lead from OF2 on control board (See Fig. 15.) Tape to prevent grounding.
3. Restart unit in heating mode, allowing frost to accumulate on outdoor coil.
4. After a few minutes in heating mode, liquid line temperature should drop below closing point of defrost thermostat (approximately 30°F).

NOTE: Unit will remain in defrost until defrost thermostat reopens at approximately 80°F coil temperature at liquid line or remainder of defrost cycle time.

5. Turn off power to outdoor and reconnect fan motor lead to OF2 on control board after above forced defrost cycle.

Step 15—Check Charge

Factory charge is shown on unit rating plate. To check charge in cooling mode, refer to Cooling Only Procedure. To check charge in heating mode, refer to Heating Check Chart Procedure.

COOLING ONLY PROCEDURE

NOTE: If subcooling charging conditions are not favorable, charge must be weighed in accordance with unit rating plate ± 0.6 oz/ft of 3/8-in. liquid line above or below 15 ft respectively.

EXAMPLE:

To calculate additional charge required for a 25-ft line set:

$$25 \text{ ft} - 15 \text{ ft} = 10 \text{ ft} \times 0.6 \text{ oz/ft} = 6 \text{ oz of additional charge}$$

Units installed with cooling mode TXV require charging with the subcooling method.

1. Operate unit a minimum of 10 minutes before checking charge.
2. Measure liquid service valve pressure by attaching an accurate gage to service port.
3. Measure liquid line temperature by attaching an accurate thermistor type or electronic thermometer to liquid line near outdoor coil.
4. Refer to unit rating plate for required subcooling temperature.
5. Refer to Table 3. Find the point where required subcooling temperature intersects measured liquid service valve pressure.
6. To obtain required subcooling temperature at a specific liquid line pressure, add refrigerant if liquid line temperature is higher than indicated or reclaim refrigerant if temperature is lower. Allow a tolerance of $\pm 3^\circ\text{F}$.

HEATING CHECK CHART PROCEDURE

To check system operation during heating cycle, refer to the Heating Check Chart on outdoor unit. This chart indicates whether a correct relationship exists between system operating pressure and air temperature entering indoor and outdoor units. If pressure and temperature do not match on chart, system refrigerant charge may not be correct. Do not use chart to adjust refrigerant charge.

NOTE: When charging is necessary during heating season, charge must be weighed in accordance with unit rating plate ± 0.6 oz/ft of 3/8-in. liquid line above or below 15 ft respectively.

EXAMPLE:

To calculate additional charge required for a 25-ft line set:

$$25 \text{ ft} - 15 \text{ ft} = 10 \text{ ft} \times 0.6 \text{ oz/ft} = 6 \text{ oz of additional charge}$$

Table 3—Required Liquid-Line Temperature ($^\circ\text{F}$)

LIQUID PRESSURE AT SERVICE VALVE (PSIG)	REQUIRED SUBCOOLING TEMPERATURE ($^\circ\text{F}$)			
	5	10	15	20
134	71	66	61	56
141	74	69	64	59
148	77	72	67	62
156	80	75	70	65
163	83	78	73	68
171	86	81	76	71
179	89	84	79	74
187	92	87	82	77
196	95	90	85	80
205	98	93	88	83
214	101	96	91	86
223	104	99	94	89
233	107	102	97	92
243	110	105	100	95
253	113	108	103	98
264	116	111	106	101
274	119	114	109	104
285	122	117	112	107
297	125	120	115	110
309	128	123	118	113
321	131	126	121	116
331	134	129	124	119
346	137	132	127	122
359	140	135	130	125

Step 16—Final Checks

IMPORTANT: Before leaving job, be sure to do the following:

1. Securely fasten all panels and covers.
2. Tighten service valve stem caps to 1/12-turn past finger tight.
3. Leave User's Manual with owner. Explain system operation and periodic maintenance requirements outlined in manual.
4. Fill out Dealer Installation Checklist and place in customer file.

CARE AND MAINTENANCE

For continuing high performance and to minimize possible equipment failure, periodic maintenance must be performed on this equipment.

Frequency of maintenance may vary depending upon geographic areas, such as coastal applications.