

Visit www.carrier.com

Installation, Start-Up, and Service Instructions

NOTE: Read the entire instruction manual before starting the installation.

This symbol → indicates a change since the last issue.

TABLE OF CONTENTS

SAFETY CONSIDERATIONS	1
Introduction	4
Receiving and Installation.....	4
Check Equipment.....	4
Provide Unit Support.....	4
Provide Clearances.....	6
Rig and Place Unit.....	6
Select and Install Ductwork	7
Provide for Condensate Disposal	8
Install Electrical Connections.....	8
PRE-START-UP	10
START-UP.....	16
Check for Refrigerant Leaks	16
Start-Up Adjustments.....	16
Defrost Control	19
MAINTENANCE.....	21
Air Filter.....	22
Indoor Blower and Motor.....	22
Outdoor Coil, Indoor Coil, and Condensate Drain Pan	22
Outdoor Fan	23
Electrical Controls and Wiring.....	23
Refrigerant Circuit	23
Indoor Airflow	23
Metering Devices—Accurater Piston.....	23
Pressure Switches.....	23
Loss of Charge Switch	23
High-Pressure Switch.....	23
Copeland Scroll Compressor (Puron Refrigerant).....	23
Refrigerant System.....	24
System Information.....	24
TROUBLESHOOTING	25
Start-Up Checklist.....	25
NOTE TO INSTALLER — READ THESE INSTRUCTIONS CAREFULLY AND COMPLETELY before installing this unit. Also, make sure the Owner's Manual and Service Instructions are left with the unit after installation.	

SAFETY CONSIDERATIONS

Installation and servicing of air-conditioning equipment can be hazardous due to system pressure and electrical components. Only trained and qualified personnel should install, repair, or service air-conditioning equipment.

Untrained personnel can perform basic maintenance functions of cleaning coils and filters. All other operations should be performed

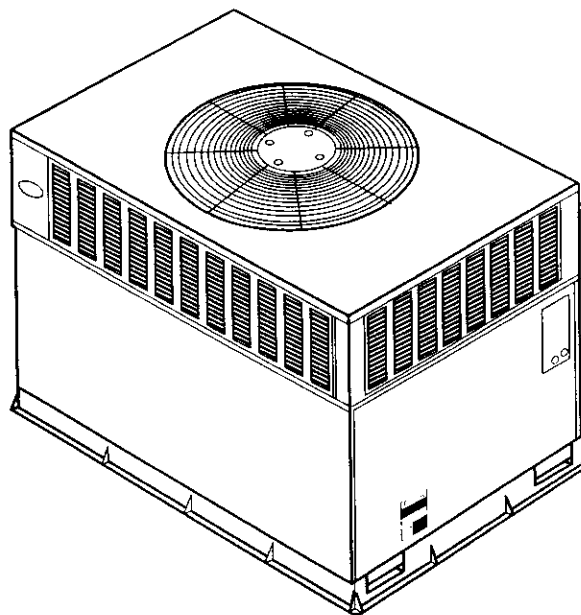

C99064

Fig. 1—Unit 50JZ

by trained service personnel. When working on air-conditioning equipment, observe precautions in the literature, tags, and labels attached to the unit, and other safety precautions that may apply.

Follow all safety codes. Wear safety glasses and work gloves. Use quenching cloth for unbrazing operations. Have fire extinguisher available for all brazing operations.

⚠ WARNING

Improper installation, adjustment, alteration, service, maintenance, or use can cause explosion, fire, electric shock, or other occurrences, which could cause serious injury or death or damage your property. Consult a qualified installer or service agency for information or assistance. The qualified installer or agency must use only factory-authorized kits or accessories when modifying this product.

Recognize safety information. This is the safety-alert symbol ⚠. When you see this symbol on the product or in instructions or manuals, be alert to the potential for personal injury.

Understand the signal words — DANGER, WARNING, CAUTION, and NOTE. Danger identifies the most serious hazards, which **will** result in severe personal injury or death. Warning indicates a condition that **could** cause serious personal injury or death. Caution is used to identify unsafe practices, which **would** result in minor personal injury or product and property damage. NOTE is used to highlight suggestions which **will** result in enhanced installation, reliability, or operation.

Manufacturer reserves the right to discontinue, or change at any time, specifications or designs without notice and without incurring obligations.

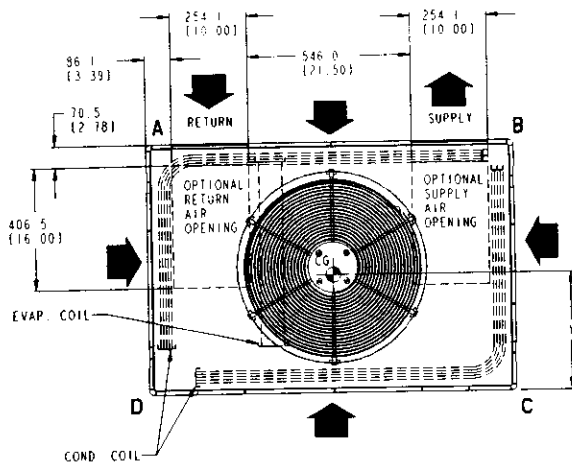

TOP VIEW

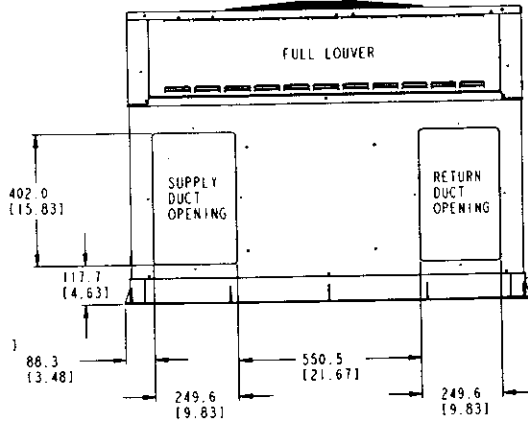

REAR VIEW

REQUIRED CLEARANCES TO COMBUSTIBLE MATL.

	MILLIMETERS (IN)
TOP OF UNIT	355.6 (14.00)
DUCT SIDE OF UNIT	50.8 (2.00)
SIDE OPPOSITE DUCTS	355.6 (14.00)
BOTTOM OF UNIT	12.7 (0.50)
ELECTRIC HEAT PANEL	914.4 (36.00)

NEC REQUIRED CLEARANCES

	MILLIMETERS (IN)
BETWEEN UNITS, POWER ENTRY SIDE	1066.8 (42.00)
UNIT AND UNGROUNDED SURFACES, POWER ENTRY SIDE	914.0 (36.00)
UNIT AND BLOCK OR CONCRETE WALLS AND OTHER GROUNDED SURFACES, POWER ENTRY SIDE	1066.8 (42.00)

MINIMUM CLEARANCES FOR OPERATION AND SERVICING

	MILLIMETERS (IN)
EVAP. COIL ACCESS SIDE	914.0 (36.00)
POWER ENTRY SIDE (EXCEPT FOR NEC REQUIREMENTS)	914.0 (36.00)
UNIT TOP	914.0 (36.00)
SIDE OPPOSITE DUCTS	914.0 (36.00)
DUCT PANEL	304.8 (12.00)

*MINIMUM DISTANCES, IF UNIT IS PLACED LESS THAN 304.8 (12.00) FROM WALL SYSTEM, THEN SYSTEM PERFORMANCE MAYBE COMPROMISED.

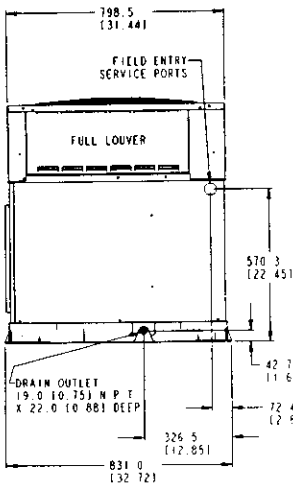

LEFT SIDE VIEW

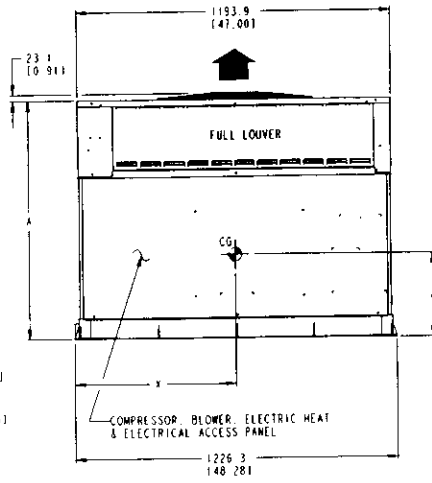

FRONT VIEW

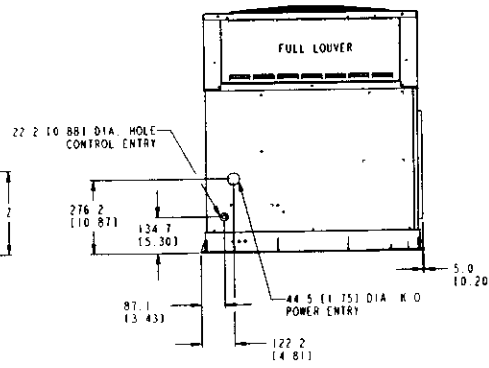

RIGHT SIDE VIEW

C00160

UNIT	ELECTRICAL CHARACTERISTICS	UNIT WEIGHT		UNIT HEIGHT IN. (MM) "A"	CENTER OF GRAVITY IN. (MM)		
		lb.	kg		X	Y	Z
50JZ024	208/230-1-60	299	135.6	35.02 (889.5)	19.0 (482.6)	18.3 (463.6)	16.0 (406.4)
50JZ030	208/230-1-60,208/230-3-60	320	145.2	37.02 (940.3)	20.0 (508.0)	19.3 (489.0)	17.6 (447.0)
50JZ036	208/230-1-60,208/230-3-60, 460-3-60	328	148.8	37.02 (940.3)	20.0 (508.0)	19.0 (482.6)	16.5 (419.1)

Fig. 2—50JZ024-036 Unit Dimensions

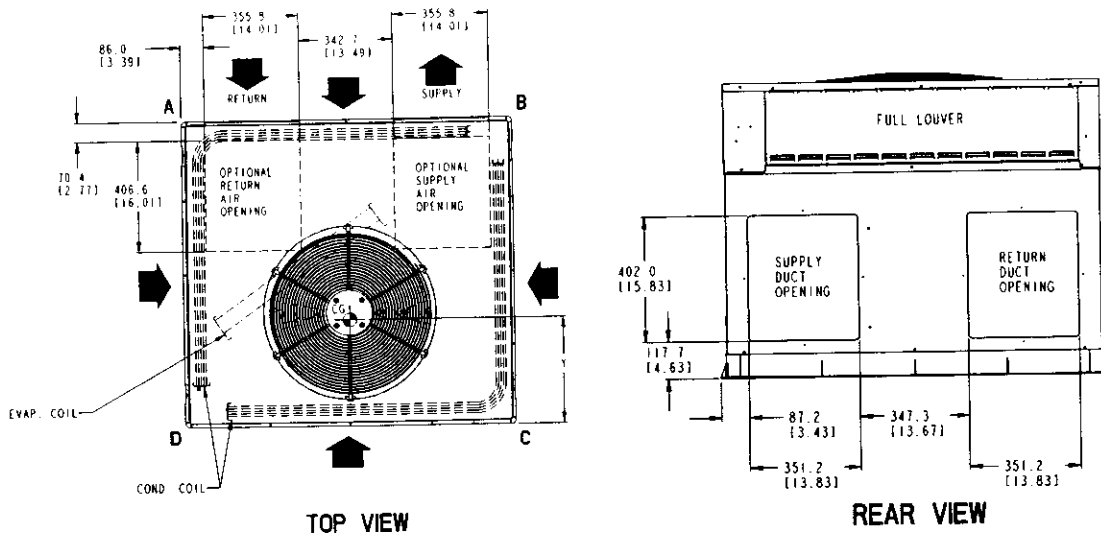

REQUIRED CLEARANCES TO COMBUSTIBLE MATL.

	MILLIMETERS (IN)
TOP OF UNIT.....	355.6 (14.00)
DUCT SIDE OF UNIT.....	50.8 (2.00)
SIDE OPPOSITE DUCTS.....	355.6 (14.00)
BOTTOM OF UNIT.....	12.7 (0.50)
ELECTRIC HEAT PANEL.....	914.4 (36.00)

NEC. REQUIRED CLEARANCES.

	MILLIMETERS (IN)
BETWEEN UNITS, POWER ENTRY SIDE.....	1066.8 (42.00)
UNIT AND UNGROUNDED SURFACES, POWER ENTRY SIDE.....	914.0 (36.00)
UNIT AND BLOCK OR CONCRETE WALLS AND OTHER GROUNDED SURFACES, POWER ENTRY SIDE.....	1066.8 (42.00)

REQUIRED CLEARANCE FOR OPERATION AND SERVICING

	MILLIMETERS (IN)
EVAP. COIL ACCESS SIDE.....	914.0 (36.00)
POWER ENTRY SIDE.....	914.0 (36.00)
(EXCEPT FOR NEC REQUIREMENTS).....	914.0 (36.00)
UNIT TOP.....	914.0 (36.00)
SIDE OPPOSITE DUCTS.....	914.0 (36.00)
DUCT PANEL.....	304.8 (12.00)*

*MINIMUM DISTANCES IF UNIT IS PLACED LESS THAN 304.8 (12.00) FROM WALL SYSTEM, THEN SYSTEM PERFORMANCE MAYBE COMPROMISED.

DIMENSIONS IN () ARE IN INCHES

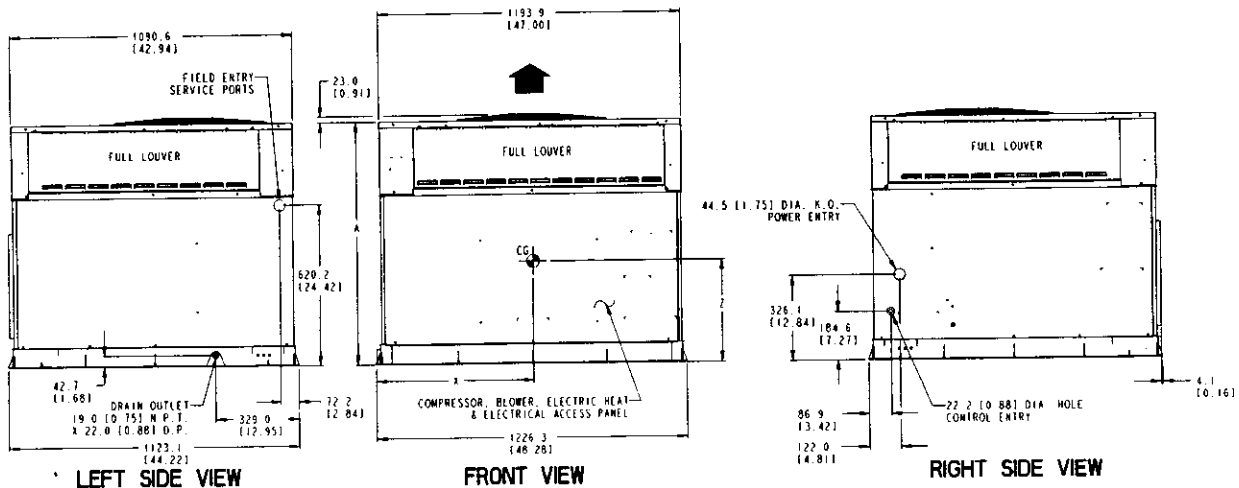

C00161

UNIT	ELECTRICAL CHARACTERISTICS	UNIT WEIGHT		UNIT HEIGHT IN. (MM) "A"	CENTER OF GRAVITY IN. (MM)		
		lb.	kg		X	Y	Z
50JZ042	208/230-1-60, 208/230-3-60, 460-3-60	350	158.8	40.98 (1040.9)	21.0 (533.4)	20.5 (520.7)	16.6 (421.6)
50JZ048	208/230-1-60, 208/230-3-60, 460-3-60	355	161.0	40.98 (1040.9)	20.0 (508.0)	21.3 (539.8)	18.0 (457.2)
50JZ060	208/230-1-60, 208/230-3-60, 460-3-60	428	194.1	42.98 (1091.7)	21.0 (533.4)	20.0 (508.0)	17.6 (447.0)

Fig. 3—50JZ 042-060 Unit Dimensions

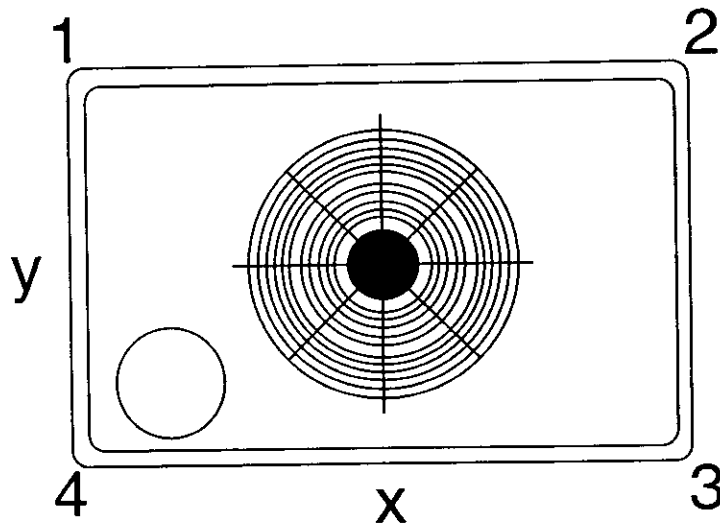

C00071

CORNER WEIGHTS (SMALL CABINET)					CORNER WEIGHTS (LARGE CABINET)				
Model 50JZ	Unit	24	30	36	Model 50JZ	Unit	42	48	60
	Total Weight	299	320	328		Total Weight	350	355	428
	Corner Weight 1	63	63	64		Corner Weight 1	75	76	92
	Corner Weight 2	62	74	76		Corner Weight 2	49	50	60
	Corner Weight 3	56	56	58		Corner Weight 3	95	96	116
	Corner Weight 4	118	127	130		Corner Weight 4	131	133	160

Fig. 4—Corner Weights

1. The power supply (volts, phase, and hertz) must correspond to that specified on unit rating plate.
2. The electrical supply provided by the utility must be sufficient to handle load imposed by this unit.
3. This installation must conform with local building codes and with NEC (National Electrical Code). Refer to provincial and local plumbing or waste water codes and other applicable local codes.

⚠ WARNING

Before performing service or maintenance operations on system, turn off main power to unit. Turn off accessory heater power switch if applicable. Electrical shock could cause severe injury or death.

⚠ CAUTION

Puron (R-410A) systems operate at higher pressures than standard R-22 systems. DO not use R-22 service equipment or components on Puron (R-410A) equipment. Ensure service equipment is rated for Puron (R-410A)

INTRODUCTION

The 50JZ heat pump is fully self-contained and designed for outdoor installation (See Fig. 1). Standard units are shipped in a horizontal-discharge configuration for installation on a ground-level slab. Standard units can be converted to downflow (vertical) discharge configurations for rooftop applications.

RECEIVING AND INSTALLATION

Step 1—Check Equipment

IDENTIFY UNIT

The unit model number and serial number are stamped on the unit identification plate. Check this information against shipping papers.

INSPECT SHIPMENT

Inspect for shipping damage while unit is still on shipping pallet. If unit appears to be damaged or is torn loose from its anchorage, have it examined by transportation inspectors before removal. Forward claim papers directly to transportation company. Manufacturer is not responsible for any damage incurred in transit. Check all items against shipping list. Immediately notify the nearest Carrier Air Conditioning office if any item is missing. To prevent loss or damage, leave all parts in original packages until installation.

Step 2—Provide Unit Support

ROOF CURB

Install accessory roof curb in accordance with instructions shipped with curb (See Fig. 5). Install insulation, cant strips, roofing, and flashing. Ductwork must be attached to curb.

IMPORTANT: The gasketing of the unit to the roof curb is critical for a watertight seal. Install gasketing material supplied with the roof curb. Improperly applied gasketing also can result in air leaks and poor unit performance.

Curb should be level to within 1/4 in. (See Fig. 6). This is necessary for unit drain to function properly. Refer to accessory roof curb installation instructions for additional information as required.

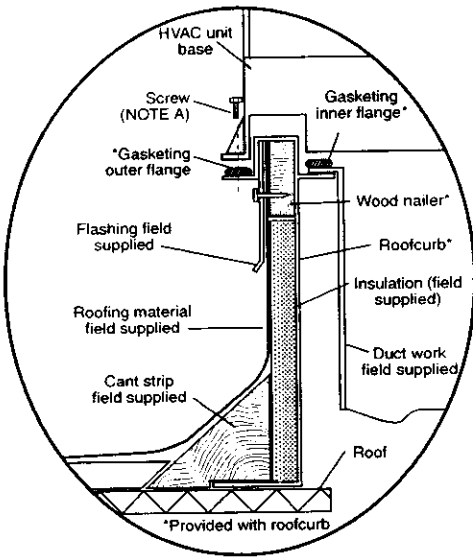

Roof Curb for Small Cabinet

Note A: When unit mounting screw is used, retainer bracket must also be used.

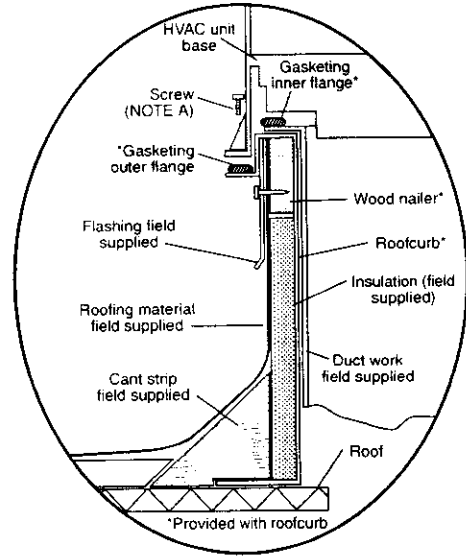

Roof Curb for Large Cabinet

Note A: When unit mounting screw is used, retainer bracket must also be used.

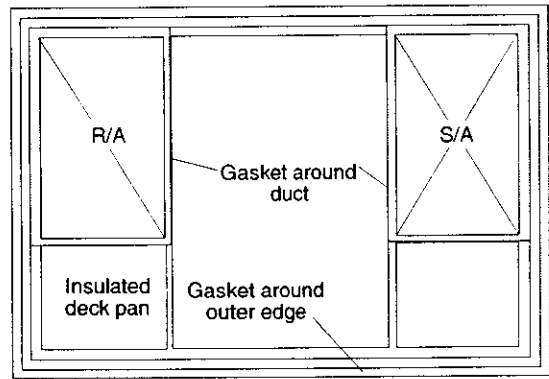
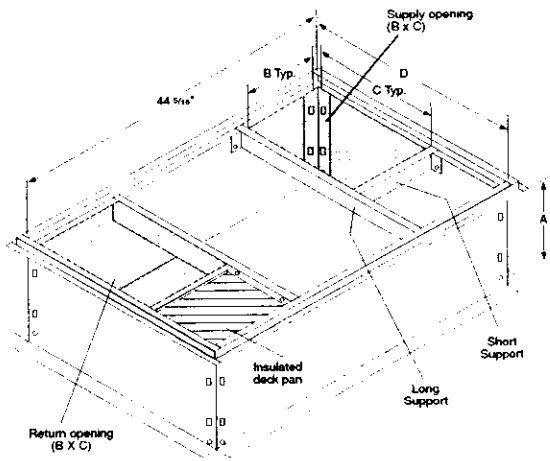

C00076

UNIT SIZE	ODS CATALOG NUMBER	A IN. (MM)	B IN. (MM)	C IN. (MM)	D IN. (MM)
50JZ024-036	CPRFCURB006A00	8 (203)	11(279)	16 1/2 (419)	28-3/4 (730)
	CPRFCURB007A00	14 (356)	11(279)	16 1/2 (419)	28-3/4 (730)
50JZ042-060	CPRFCURB008A00	8 (203)	16 3/16 (411)	17 3/8 (441)	40-1/4 (1022)
	CPRFCURB009A00	14 (356)	16 3/16 (411)	17 3/8 (441)	40-1/4 (1022)

NOTES:

1. Roof curb must be set up for unit being installed.
2. Seal strip must be applied, as required, to unit being installed.
3. Dimensions in () are in millimeters.
4. Roof curb is made of 16-gage steel.
5. Table lists only the dimensions, per part number, that have changed.
6. Attach ductwork to curb (flanges of duct rest on curb).
7. Insulated panels: 1-in. thick fiberglass 1 lb density.
8. Dimensions are in inches.
9. When unit mounting screw is used (see Note A), a retainer bracket must be used as well. This bracket must also be used when required by code for hurricane or seismic conditions. This bracket is available through Micromet.



Fig. 5—Roof Curb Dimensions

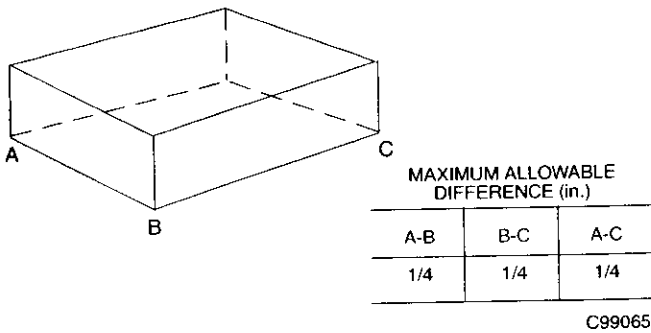

Fig. 6—Unit Leveling Tolerances

SLAB MOUNT

Place the unit on a solid, level concrete pad that is a minimum of 4 in. thick with 2 in. above grade (See Fig. 7). The slab should extend approximately 2 in. beyond the casing on all 4 sides of the unit. Do not secure the unit to the slab *except* when required by local codes.

GROUND MOUNT

The unit may be installed either on a slab or placed directly on the ground if local codes permit. Place the unit on level ground prepared with gravel for condensate discharge.

Step 3—Provide Clearances

The required minimum service clearances are shown in Figs. 2 and 3. Adequate ventilation and outdoor air must be provided. The outdoor fan draws air through the outdoor coil and discharges it through the top fan grill. Be sure that the fan discharge does not recirculate to the outdoor coil. Do not locate the unit in either a corner or under an overhead obstruction. The minimum clearance under a partial overhang (such as a normal house overhang) is 48 in. above the unit top. The maximum horizontal extension of a partial overhang must not exceed 48 in.

IMPORTANT: Do not restrict outdoor airflow. An air restriction at either the outdoor-air inlet or the fan discharge may be detrimental to compressor life.

Do not place the unit where water, ice, or snow from an overhang or roof will damage or flood the unit. Do not install the unit on carpeting or other combustible materials. Slab-mounted units should be at least 4 in. above the highest expected water and runoff levels. Do not use unit if it has been under water.

Step 4—Rig and Place Unit

Rigging and handling of this equipment can be hazardous for many reasons due to the installation location (roofs, elevated structures, etc.)

Only trained, qualified crane operators and ground support staff should handle and install this equipment.

When working with this equipment, observe precautions in the literature, on tags, stickers, and labels attached to the equipment, and any other safety precautions that might apply.

Follow all applicable safety codes. Wear safety shoes and work gloves.

INSPECTION

Prior to initial use, and at monthly intervals, all rigging brackets and straps should be visually inspected for any damage, evidence of wear, structural deformation, or cracks. Particular attention should be paid to excessive wear at hoist hooking points and load support areas. Brackets or straps showing any kind of wear in these areas must not be used and should be discarded.

INSTALLATION

1. Remove unit from shipping carton. Leave top shipping skid on the unit as a spreader bar to prevent the rigging straps from damaging the unit. If the wood skid is not available, use a spreader bar of sufficient length to protect unit from damage.
2. Position the lifting bracket assembly around the base of the unit. Be sure the strap does not twist.
3. Place each of the 4 metal lifting brackets into the handholds in the composite pan.
4. Thread lifting bracket strapping around bottom perimeter of unit as follows:
 - a. Open lever of tension buckle (ratchet type).
 - b. Feed strapping through tension buckle as shown in Fig. 8.
 - c. Pull strapping through tension buckle unit taut.
 - d. Snap lever down to lock strap in tension buckle. To release strapping, squeeze safety latch, lift lever, and pull webbing outward.
5. Tighten the tension buckle until it is taut. Lifting brackets must be secure in the handholds.
6. Attach field-supplied clevis or hook of sufficient strength to hole in the lifting bracket (See Fig. 9).

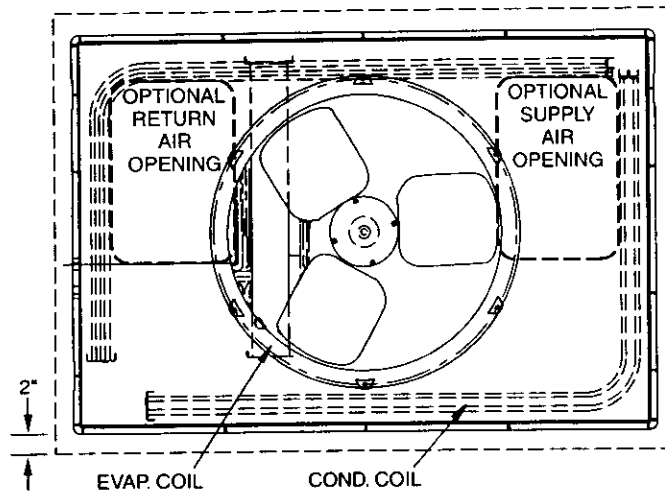
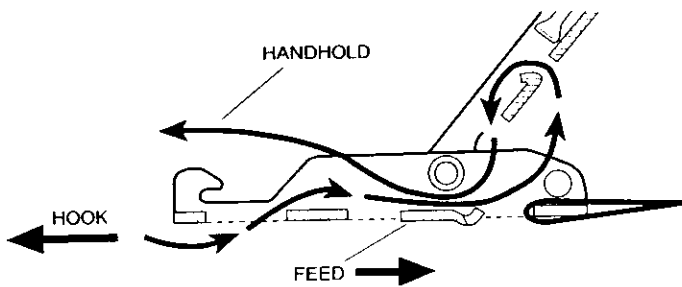
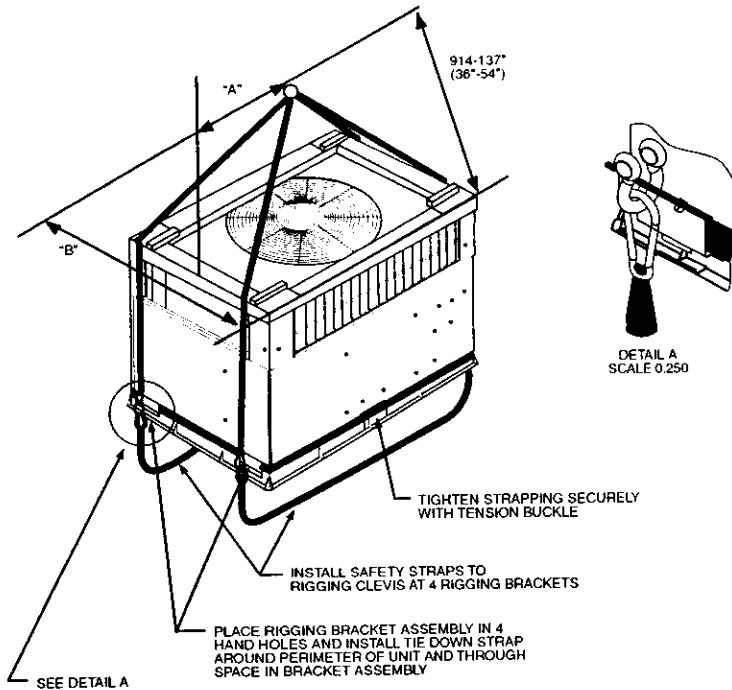

Fig. 7—Slab Mounting Detail



C99067

Fig. 8—Threading Belt



C99075

UNIT Size	MAXIMUM WEIGHT		A		B	
	lb.	kg	in.	mm.	in.	mm.
50JZ024	321	145.6	19.0	482.6	18.25	463.6
50JZ030	342	155.2	20.0	508	19.25	489
50JZ036	350	158.8	20.0	508	19.0	482.6
50JZ042	372	168.8	21.0	533.4	20.5	520.7
50JZ048	377	171.0	20.0	508	21.25	539.8
50JZ060	450	204.2	21.0	533.4	20.0	508.0

Fig. 9—Suggested Rigging

- Attach the 2 safety straps directly to the clevis or hook at the 4 rigging brackets. **DO NOT** attach the safety straps to the lifting brackets (See Fig. 9).
- Position lifting point directly over the unit's center of gravity.
- Lift unit. When unit is directly over the roof curb, remove the 2 safety straps. Lower the equipment onto the roof curb.
- After the unit is placed on the roof curb or mounting pad, remove the top crating. On 50JZ060 units only, 2 wire ties fastened to the outdoor coils and reversing valve/accumulator assembly must be cut. Remove the left and front louver panels and corner post to access wire ties. The wire tie to be cut on the left is located approximately 4" down the tube sheet. The wire tie to be cut on the right is located approximately 6" down the tube sheet.

Step 5—Select and Install Ductwork

The design and installation of the duct system must be in accordance with the standards of the NFPA for installation of

non-residence type air conditioning and ventilating systems, NFPA 90A or residence-type, NFPA 90B and/or local codes and ordinances.

Select and size ductwork, supply-air registers, and return air grilles according to ASHRAE (American Society of Heating, Refrigeration, and Air Conditioning Engineers) recommendations.

The unit has duct flanges on the supply- and return-air openings on the side of the unit.

When designing and installing ductwork, consider the following:

⚠ WARNING

For vertical supply and return units, tools or parts could drop into ductwork and cause serious injury or death. Install a 90 degree turn in the return ductwork between the unit and the conditioned space. If a 90 degree elbow cannot be installed, then a grille of sufficient strength and density should be installed to prevent objects from falling into the conditioned space. Units with electric heaters require 90 degree elbow in supply duct.

- All units should have field-supplied filters or accessory filter rack installed in the return-air side of the unit. Recommended sizes for filters are shown in Table 1.
- Avoid abrupt duct size increases and reductions. Abrupt change in duct size adversely affects air performance.

IMPORTANT: Use flexible connectors between ductwork and unit to prevent transmission of vibration. Use suitable gaskets to ensure weather tight and airtight seal. When electric heat is installed, use fireproof canvas (or similar heat resistant material) connector between ductwork and unit discharge connection. If flexible duct is used, insert a sheet metal sleeve inside duct. Heat resistant duct connector (or sheet metal sleeve) must extend 24-in. from electric heater element.

- Size ductwork for cooling air quantity (cfm). The minimum air quantity for proper electric heater operation is listed in Table 2. Heater limit switches may trip at air quantities below those recommended.
- Seal, insulate, and weatherproof all external ductwork. Seal, insulate and cover with a vapor barrier all ductwork passing through conditioned spaces. Follow latest Sheet Metal and Air Conditioning Contractors National Association (SMACNA) and Air Conditioning Contractors Association (ACCA) minimum installation standards for residential heating and air conditioning systems.
- Secure all ducts to building structure. Flash, weatherproof, and vibration-isolate duct openings in wall or roof according to good construction practices.

CONVERTING HORIZONTAL DISCHARGE UNITS TO DOWNFLOW (VERTICAL) DISCHARGE UNITS

⚠ WARNING

Before performing service or maintenance operations on system, turn off main power to unit. Turn off accessory heater power switch if applicable. Electrical shock could cause serious injury or death.

- Open all electrical disconnects before starting any service work.
- Remove horizontal duct covers to access bottom return and supply knock out panels.
- Use a screwdriver and hammer to remove the panels in the bottom of the base pan.

Table 1—Physical Data—Unit 50JZ

UNIT SIZE	50JZ024	50JZ030	50JZ036	50JZ042	50JZ048	50JZ060
NOMINAL CAPACITY (ton)	2	2-1/2	3	3-1/2	4	5
OPERATING WEIGHT (lb.)	299	320	328	350	355	428
COMPRESSOR QUANTITY	1					
TYPE	SCROLL COMPRESSOR					
REFRIGERANT	R-410A					
REFRIGERANT METERING DEVICE	Accurater					
Refrigerant (R-410A) Quantity (lb.)	7.0	8.9	9.3	9.5	10.6	12.4
ORIFICE ID (in.)	0.061	0.061	0.067	0.073	0.076	0.088
ORIFICE OD (in.)	0.032 (2)	0.040 (2)	0.040 (2)	0.038 (2)	0.046 (2)	0.052 (2)
OUTDOOR COIL Rows... Fins/in. face area (sq. ft.)	2...17 8.5	2...17 10.3	2...17 10.3	2...17 13.5	2...17 13.5	2...17 15.4
OUTDOOR FAN Nominal Airflow (CFM) Diameter Motor HP (RPM)	2350 22 1/8 (825)	2350 22 1/8 (825)	2800 22 1/4 (1100)	2500 22 1/8 (825)	3300 22 1/4 (1100)	3300 22 1/4 (1100)
INDOOR COIL Rows... Fins/in. face area (sq. ft.)	3...15 3.7	3...15 3.7	4...15 3.7	3...15 4.7	4...15 4.7	4...15 5.7
INDOOR BLOWER Nominal Airflow (CFM) Size (in.) Motor (HP)	800 10x10 1/4	1000 10x10 1/4	1200 10x10 1/2	1400 11x10 1/2	1600 11x10 1/2	1750 11x10 1
HIGH-PRESSURE SWITCH (psig) Cutout Reset (Auto)	610 ± 15 420 ± 25					
LOSS-OF-CHARGE/LOW-PRESSURE SWITCH (Liquid Line) (psig) Cutout Reset (Auto)	20 ± 5 45 ± 10					
RETURN-AIR FILTERS (in.)* throwaway	20x20x1	20x20x1	20x24x1	24x30x1	24x30x1	24x30x1

* Required filter sizes shown are based on the larger of the ARI (Air Conditioning and Refrigeration Institute) rated cooling airflow or the heating airflow velocity of 300 ft/minute for throwaway type or 450 ft/minute for high-capacity type. Air filter pressure drop for non-standard filters must not exceed 0.08 in. wg.

NOTE: These panels are held in place with tabs similar to an electrical knockout.

- Reinstall the horizontal duct covers (Fig. 11) to block off the horizontal air openings.

NOTE: Avoid abrupt duct size increases and reductions. Abrupt change in duct size adversely affects air performance.

Step 6—Provide for Condensate Disposal

NOTE: Ensure that condensate-water disposal methods comply with local codes, restrictions, and practices.

The 50JZ units dispose of condensate through a 3/4 in. NPT female fitting that exits on the compressor end of the unit. Condensate water can be drained directly onto the roof in rooftop installations (where permitted) or onto a gravel apron in ground level installations. Install a field-supplied condensate trap at end of condensate connection to ensure proper drainage. Make sure that the outlet of the trap is at least 1 in. lower than the drain-pan condensate connection to prevent the pan from overflowing. Prime the trap with water. When using a gravel apron, make sure it slopes away from the unit.

If the installation requires draining the condensate water away from the unit, install a field-supplied 2 -in. trap at the condensate connection to ensure proper drainage. Condensate trap is available as an accessory or is field-supplied. Make sure that the outlet of the trap is at least 1 in. lower than the unit drain-pan condensate connection to prevent the pan from overflowing. Connect a drain trough using a minimum of field-supplied 3/4 -in. PVC or field-supplied 3/4 -in. copper pipe at outlet end of the 2 -in. trap (See Fig. 12). Do not undersize the tube. Pitch the drain trough

downward at a slope of at least 1 in. every 10 ft. of horizontal run. Be sure to check the drain trough for leaks. Prime the trap at the beginning of the cooling season start-up.

Step 7—Install Electrical Connections

⚠ WARNING

The unit cabinet must have an uninterrupted, unbroken electrical ground to minimize the possibility of personal injury if an electrical fault should occur. This ground may consist of an electrical wire connected to the unit ground lug in the control compartment, or conduit approved for electrical ground when installed in accordance with NEC, ANSI/NFPA American National Standards Institute/National Fire Protection Association (latest edition) (in Canada, Canadian Electrical Code CSA C22.1) and local electrical codes. Failure to adhere to this warning could result in serious injury or death.

Table 2—Minimum Airflow for Reliable Electric Heater Operation (Cfm)

SIZE	50JZ024	50JZ030	50JZ036	50JZ042	50JZ048	50JZ060
AIRFLOW (CFM)	800	1000*	1200	1400	1600	2000

* The 030 size models must be run on medium or high speed when used in conjunction with 15 kW electric heat accessory

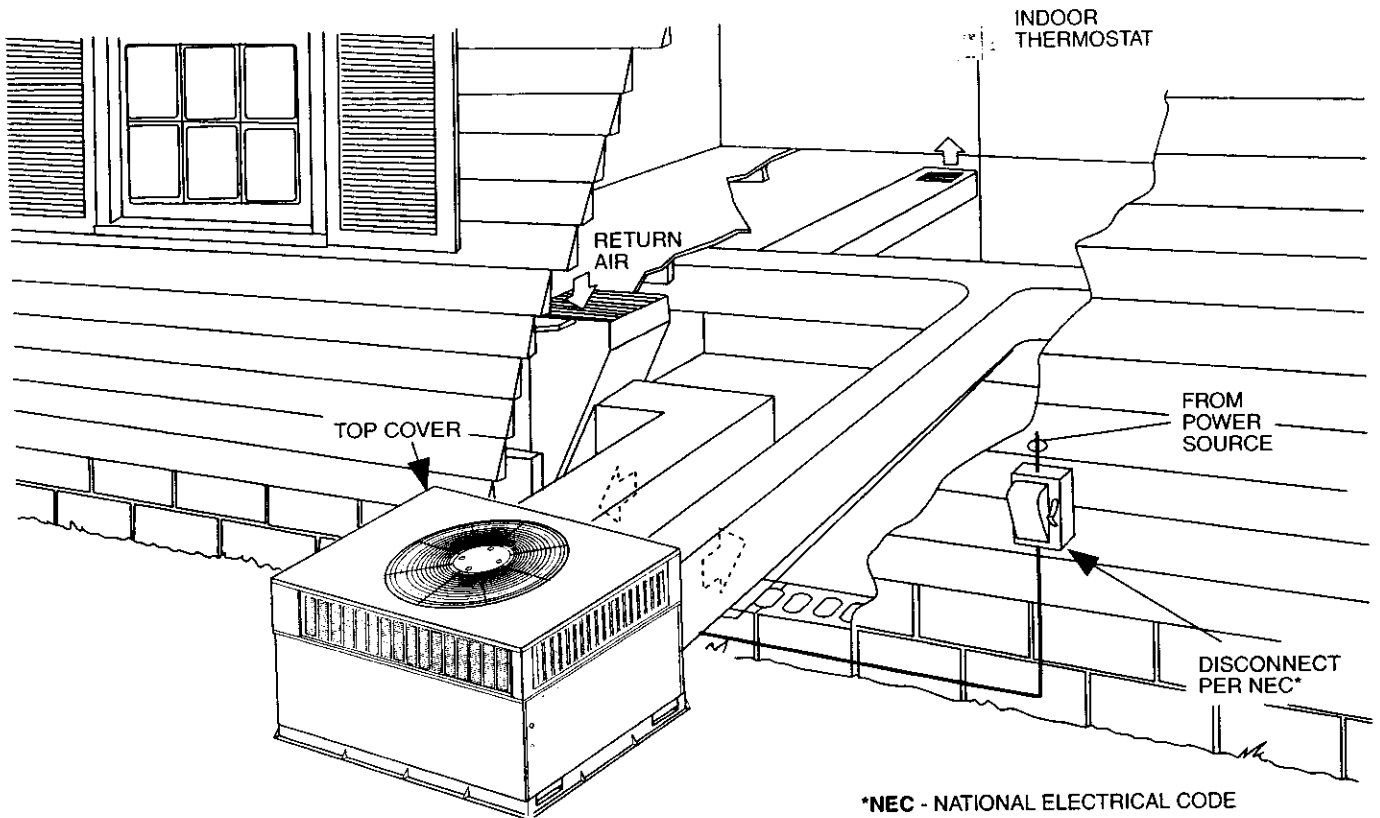

C00063

Fig. 10—Typical Installation

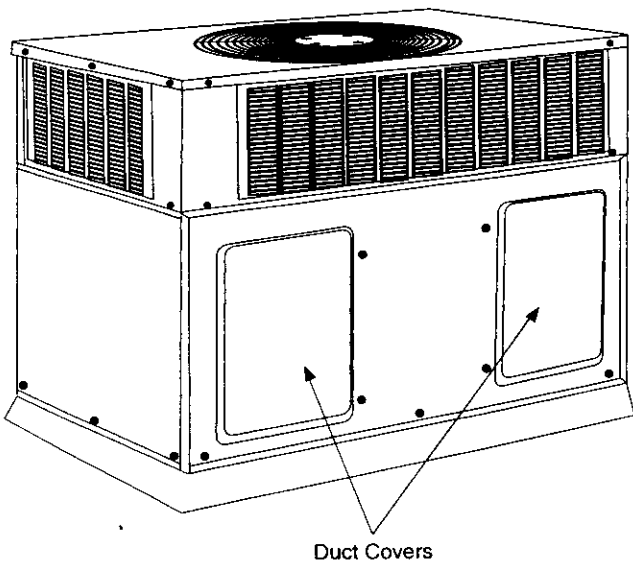

C00092

Fig. 11—50JZ with Duct Covers On

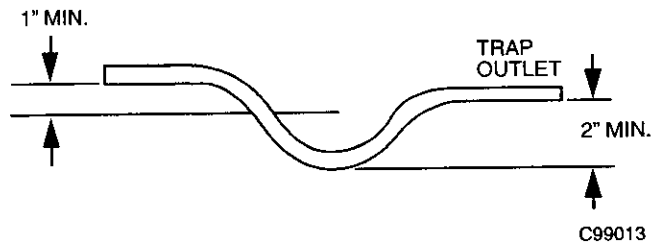

C99013

Fig. 12—Condensate Trap

⚠ CAUTION

Failure to follow these precautions could result in damage to the unit being installed:

1. Make all electrical connections in accordance with NEC ANSI/NFPA (latest edition) and local electrical codes governing such wiring. In Canada, all electrical connections must be in accordance with CSA standard C22.1 Canadian Electrical Code Part 1 and applicable local codes. Refer to unit wiring diagram.
2. Use only *copper* conductor for connections between field-supplied electrical disconnect switch and unit. **DO NOT USE ALUMINUM WIRE.**
3. Be sure that high-voltage power to unit is within operating voltage range indicated on unit rating plate. On 3-phase units, ensure phases are balanced within 2 percent. Consult local power company for correction of improper voltage and/or phase imbalance.
4. Insulate low-voltage wires for highest voltage contained within conduit when low-voltage control wires are in same conduit as high-voltage wires.
5. Do not damage internal components when drilling through any panel to mount electrical hardware, conduit, etc.

HIGH-VOLTAGE CONNECTIONS

The unit must have a separate electrical service with a field-supplied, waterproof disconnect switch mounted at, or within sight from the unit. Refer to the unit rating plate, NEC and local codes for maximum fuse/circuit breaker size and minimum circuit amps (ampacity) for wire sizing (See Table 3 for electrical data).

The field-supplied disconnect may be mounted on the unit over the high-voltage inlet hole (See Figs. 2 and 3).

If the unit has an electric heater, a second disconnect may be required. Consult the Installation, Start-Up, and Service Instructions provided with the accessory for electrical service connections.

Operation of unit on improper line voltage constitutes abuse and may cause unit damage that could affect warranty.

ROUTING POWER LEADS INTO UNIT

Use only copper wire between disconnect and unit. The high-voltage leads should be in a conduit until they enter the duct panel; conduit termination at the duct panel must be watertight. Run the high-voltage leads through the power entry knockout on the power entry side panel (See Fig. 2 and 3 for location and size). When the leads are inside the unit, run leads up the high-voltage raceway to the line wiring splice box (See Fig. 13 through 15). For single-phase units, connect leads to the black and yellow wires; for 3-phase units, connect the leads to the black, yellow, and blue wires (See Fig. 18).

CONNECTING GROUND LEAD TO GROUND LUG

Refer to Fig. 18. Connect the ground lead to the chassis using the ground lug in the wiring splice box.

ROUTING CONTROL POWER WIRES (24-V)

Form a drip-loop with the thermostat leads before routing them into the unit. Route the thermostat leads through grommeted, low-voltage hole provided in unit into unit control power splice box (See Fig. 2 and 3). Connect thermostat leads to unit control power leads as shown in Fig. 17.

The unit transformer supplies 24-v power for complete system including accessory electrical heater. An automatic-reset circuit breaker (See Fig. 19) is provided in the 24-v circuit; see the caution label on the transformer or Fig. 20. Transformer is factory wired

for 230-v operation. If supply voltage is 208-v, rewire transformer primary as described in Special Procedures for 208-v Operation section.

SPECIAL PROCEDURES FOR 208-V OPERATION

1. Be sure unit disconnect switch is open.
2. Disconnect the yellow primary lead (w 110) from the transformer. See unit wiring label (See Fig. 13 and 14).
3. Connect the yellow primary lead (w110) to the transformer terminal labeled 200-v.

Indoor blower-motor speeds may need to be changed for 208-v operation. Refer to indoor airflow and airflow adjustments section.

PRE-START-UP

⚠ WARNING

Failure to observe the following warnings could result in serious personal injury or death:

1. Follow recognized safety practices and wear protective goggles when checking or servicing refrigerant system.
2. Do not operate compressor or provide any electric power to unit unless compressor terminal cover is in place and secured.
3. Do not remove compressor terminal cover until all electrical sources are disconnected.
4. Relieve and recover all refrigerant from both high- and low-pressure sides of system before touching or disturbing anything inside terminal box if refrigerant leak is suspected around compressor terminals.
5. Never attempt to repair soldered connection while refrigerant system is under pressure.
6. Do not use torch to remove any component. System contains oil and refrigerant under pressure. To remove a component, wear protective goggles and proceed as follows:
 - a. Shut off electrical power to unit.
 - b. Relieve and reclaim all refrigerant from system using both high- and low-pressure ports.
 - c. Cut component connecting tubing with tubing cutter and remove component from unit.
 - d. Carefully unsweat remaining tubing stubs when necessary. Oil can ignite when exposed to torch flame.

Use the Start-Up Checklist supplied at the end of this book and proceed as follows to inspect and prepare the unit for initial start-up:

1. Remove all access panels.
2. Read and follow instructions on all DANGER, WARNING, CAUTION, and INFORMATION labels attached to, or shipped with, unit.
3. Make the following inspections:
 - a. Inspect for shipping and handling damages such as broken lines, loose parts, disconnected wires, etc.
 - b. Inspect for oil at all refrigerant tubing connections and on unit base. Detecting oil generally indicates a refrigerant leak. Leak-test all refrigerant tubing connections using electronic leak detector, or liquid-soap solution. If a refrigerant leak is detected, see following Check for Refrigerant Leaks section.
 - c. Inspect all field and factory-wiring connections. Be sure that connections are completed and tight.
 - d. Inspect coil fins. If damaged during shipping and handling, carefully straighten fins with a fin comb.
4. Verify the following conditions:

Table 3—Electrical Data—50JZ

UNIT 50JZ SIZE	V-PH-HZ	VOLTAGE RANGE		COMPRESSOR		ODFM FLA	IDFM FLA	ELECTRIC HEAT		SINGLE POINT POWER SUPPLY		
		Min	Max	RLA	LRA			Nominal kW*	FLA	UNIT MCA	MAX FUSE OR CKT BKR	MOCP
024	208/230-1-60	187	253	13.5	61.0	0.9	2.0	3.8/5.0 7.5/10.0	18.1/20.8 36.1/41.7	19.8/19.8 42.3/45.8 64.9/71.9	30/30 50/50 -	-
030	208/230-1-60	187	253	15.9	73.0	0.9	2.1	3.8/5.0 7.5/10.0 11.3/15.0	18.1/20.8 36.1/41.7 54.2/62.5	22.9/22.9 45.4/48.9 68.0/75.0 90.6/101.0	30/30 50/50 -	-
	208/230-3-60	187	253	10.9	63.0	0.9	2.1	3.8/5.0 7.5/10.0 11.3/15.0	10.4/12.0 20.8/24.1 31.3/36.1	16.6/16.6 29.7/31.7 42.7/46.7 55.7/61.7	20/20 35/35 45/50 60/-	-
036	208/230-1-60	187	253	16.9	83.0	1.6	4.1	3.8/5.0 7.5/10.0 11.3/15.0	18.1/20.8 36.1/41.7 54.2/62.5	26.8/26.8 49.4/52.9 72.0/78.9 94.5/105.0	40/40 60/60 -	-
	208/230-3-60	187	253	12.2	77.0	1.6	4.1	3.8/5.0 7.5/10.0 11.3/15.0	10.4/12.0 20.8/24.1 31.3/36.1	21.0/21.0 34.0/36.0 47.0/51.0 60.0/66.1	30/30 40/40 50/60 -	-
	460-3-60	414	506	5.8	35.0	0.9	2.0	5.0 10.0 15.0	6.0 12.0 18.0	10.2 17.7 25.2 32.7	15 20 30 35	-
042	208/230-1-60	187	253	22.4	105.0	0.9	4.1	3.8/5.0 7.5/10.0 11.3/15.0 15.0/20.0	18.1/20.8 36.1/41.7 54.2/62.5 72.2/83.3	33.0/33.0 55.6/59.0 78.1/85.1 100.7/111.1 123.3/137.2	40/40 60/60 -	-
	208/230-3-60	187	253	15.4	88.0	0.9	4.1	3.8/5.0 7.5/10.0 11.3/15.0 15.0/20.0	10.4/12.0 20.8/24.1 31.3/36.1 41.6/48.0	24.3/24.3 37.3/39.3 50.3/54.3 63.3/69.4 76.2/84.2	30/30 50/50 60/60 -	-
	460-3-60	414	506	7.3	39.0	0.9	2.0	5.0 10.0 15.0 20.0	6.0 12.0 18.0 24.1	12.0 19.5 27.1 34.6 42.1	15 25 30 35 45	-
048	208/230-1-60	187	253	21.3	109.0	1.6	4.1	3.8/5.0 7.5/10.0 11.3/15.0 15.0/20.0	18.1/20.8 36.1/41.7 54.2/62.5 72.2/83.3	32.3/32.3 54.9/58.4 77.5/84.4 100.0/110.5 122.6/136.5	40/40 -	-
	208/230-3-60	187	253	14.7	91.0	1.6	4.1	3.8/5.0 7.5/10.0 11.3/15.0 15.0/20.0	10.4/12.0 20.8/24.1 31.3/36.1 41.6/48.0	24.1/24.1 37.1/39.1 50.1/54.1 63.2/69.2 76.0/84.0	30/30 45/50 60/60 -	-
	460-3-60	414	506	7.2	46.0	0.9	2.0	5.0 10.0 15.0 20.0	6.0 12.0 18.0 24.1	11.9 19.4 26.9 34.5 42.0	15 25 30 35 45	-
060	208/230-1-60	187	253	27.6	158.0	1.5	6.2	3.8/5.0 7.5/10.0 11.3/15.0 15.0/20.0	18.1/20.8 36.1/41.7 54.2/62.5 72.2/83.3	42.2/42.2 64.8/68.2 87.3/94.3 109.9/120.3 132.5/146.4	50/50 -	-
	208/230-3-60	187	253	19.2	137.0	1.5	6.2	3.8/5.0 7.5/10.0 11.3/15.0 15.0/20.0	10.4/12.0 20.8/24.1 31.3/36.1 41.6/48.0	31.7/31.7 44.7/46.7 57.8/61.8 70.8/76.8 83.7/91.7	40/40 50/60 -	-
	460-3-60	414	506	9.0	62.0	0.9	3.2	5.0 10.0 15.0 20.0	6.0 12.0 18.0 24.1	15.4 22.9 30.4 37.9 45.4	20 30 35 40 50	-

- LEGEND**
- FLA — Full Load Amps
 - LRA — Locked Rotor Amps
 - MCA — Minimum Circuit Amps
 - MOCP — Maximum Overcurrent Protection
 - RLA — Rated Load Amps



*Heater capacity (KW) based on heater voltage of 208v, 240v, & 480v. If power distribution voltage to unit varies from rated heater voltage, heater KW will vary accordingly.

NOTES:

1. In compliance with NEC (National Electrical Code) requirements for multimotor and combination load equipment (refer to NEC Articles 430 and 440), the overcurrent protective device for the unit shall be Power Supply fuse. The CGA (Canadian Gas Association) units may be fuse or circuit breaker.
2. Minimum wire size is based on 60 C copper wire. If other than 60 C wire is used, or if length exceeds wire length in table, determine size from NEC.
3. Unbalanced 3-Phase Supply Voltage
Never operate a motor where a phase imbalance in supply voltage is greater than 2%. Use the following formula to determine the percentage of voltage imbalance.

% Voltage imbalance
 $= 100 \times \frac{\text{max voltage deviation from average voltage}}{\text{average voltage}}$

EXAMPLE: Supply voltage is 460-3-60.

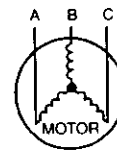

AB = 452 v
 BC = 464 v
 AC = 455 v

$$\begin{aligned} \text{Average Voltage} &= \frac{452 + 464 + 455}{3} \\ &= \frac{1371}{3} \\ &= 457 \end{aligned}$$

Determine maximum deviation from average voltage.

(AB) 457 - 452 = 5 v
 (BC) 464 - 457 = 7 v
 (AC) 457 - 455 = 2 v

Maximum deviation is 7 v.

Determine percent of voltage imbalance.

$$\begin{aligned} \% \text{ Voltage imbalance} &= 100 \times \frac{7}{457} \\ &= 1.53\% \end{aligned}$$

This amount of phase imbalance is satisfactory as it is below the maximum allowable 2%.

IMPORTANT: If the supply voltage phase imbalance is more than 2%, contact your local electric utility company immediately.

C99024

Fig. 16—Electrical Data Legend

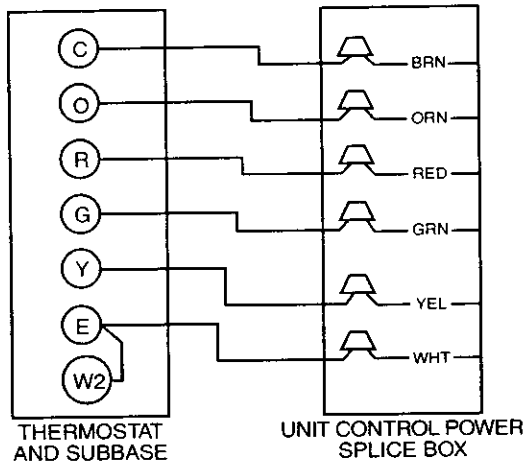

C99056

Fig. 17—Control Connections

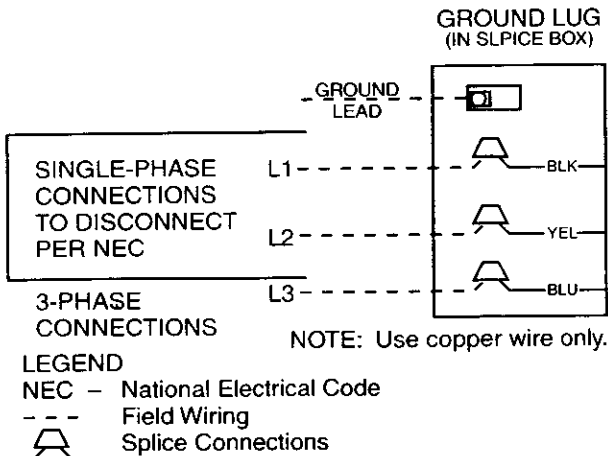

C99057

Fig. 18—Line Power Connections

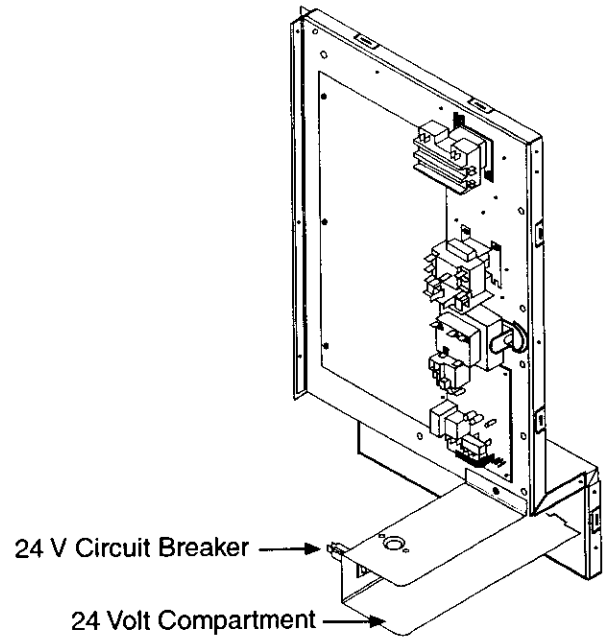

C99070

Fig. 19—Control Wiring Plate

TRANSFORMER CIRCUIT CONTAINS A MANUAL RESET OVERCURRENT PROTECTOR

IT WILL NOT AUTOMATICALLY RESET

DISCONNECT POWER PRIOR TO SERVICING

THIS COMPARTMENT MUST BE CLOSED EXCEPT WHEN SERVICING

C99058

Fig. 20—Transformer Label

- a. Make sure that outdoor-fan blade is correctly positioned in fan orifice.
 - b. Make sure that air filter(s) is in place.
 - c. Make sure that condensate drain pan and trap are filled with water to ensure proper drainage.
 - d. Make sure that – on the 060 size, only – the 2 wire ties fastened to the outdoor coils and reversing valve/accumulator have been removed.
 - e. Make sure that all tools and miscellaneous loose parts have been removed.
5. Compressors are internally spring mounted. Do not loosen or remove compressor hold-down bolts.
 6. Each unit system has 2 Schrader-type ports, one low-side Schrader fitting located on the suction line, and one high-side Schrader fitting located on the compressor discharge line. Be sure that caps on the ports are tight.

2. Place system switch or MODE control in HEAT position. Set control above room temperature. Observe that compressor, outdoor fan, and indoor blower motors start. Observe that heating cycle shuts down when control setting is satisfied.
3. When using an automatic changeover room thermostat, place both SYSTEM or MODE control and FAN mode switches in AUTO positions. Observe that unit operates in Cooling mode when temperature control is set to "call for Cooling" (below room temperature), and unit operates in Heating mode when temperature control is set to "call for Heating" (above room temperature).

IMPORTANT: Three-phase, scroll compressors are direction oriented. Unit must be checked to ensure proper compressor 3-phase power lead orientation. If not corrected within 5 minutes, the internal protector will shut off the compressor. The 3-phase power leads to the unit must be reversed to correct rotation. When turning backwards, the difference between compressor suction and discharge pressures may be dramatically lower than normal.

CHECKING AND ADJUSTING REFRIGERANT CHARGE

The refrigerant system is fully charged with R-410A refrigerant and is tested and factory sealed.

NOTE: Adjustment of the refrigerant charge is not required unless the unit is suspected of not having the proper R-410A charge. The charging label and the tables shown refer to system temperatures and pressures in Cooling mode, only. A refrigerant charging label is attached to the outside of the service access door. If charge level is suspect in Heating mode, reclaim all refrigerant and charge to nameplate amount. (This information may be obtained from the physical data table also.) The charging label and the tables shown refer to system temperatures and pressures in Cooling mode only. A refrigerant charging label is attached to the outside of the service access door. If charge level is suspect in Heating mode, reclaim all refrigerant and charge to nameplate amount. (This information may be obtained from the physical data table also.)

IMPORTANT: When evaluating the refrigerant charge, an indicated adjustment to the specified factory charge must always be very minimal. If a substantial adjustment is indicated, an abnormal condition exists somewhere in the cooling system, such as insufficient airflow across either coil or both coils.

REFRIGERANT CHARGE

The amount of refrigerant charge is listed on the unit nameplate and/or the physical data table. Refer to the Refrigeration Service Techniques Manual, Refrigerants Section.

NO CHARGE

Check for leak. Use standard evacuating techniques. After evacuating system, weigh in the specified amount of refrigerant (refer to system data plate).

LOW CHARGE COOLING

Use Cooling Charging Charts (Figs. 25-30). Vary refrigerant until the conditions of the chart are met. Note that charging charts are different from type normally used. Charts are based on charging the units to correct superheat for the various operating conditions. Accurate pressure gauge and temperature sensing devices are required. Connect the pressure gauge to the service port on the suction line. Mount the temperature sensing device on the suction line and insulate it so that the outdoor ambient does not affect the reading. Indoor air CFM must be within the normal operating range of the unit.

TO USE COOLING CHARGING CHARTS

Take the outdoor ambient temperature and read the suction pressure gauge. Refer to the chart to determine what the suction temperature should be.

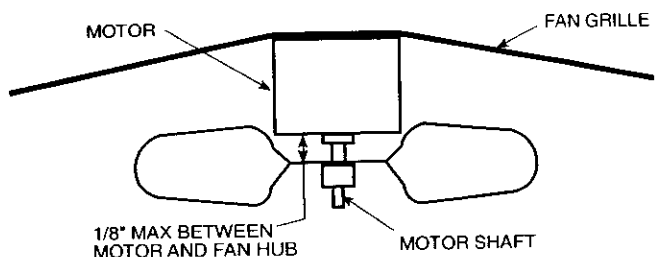

C99009

Fig. 21—Fan Blade Clearance

START-UP

Using the Start-Up Checklist supplied at the end of this book, proceed as follows:

Step 1—Check for Refrigerant Leaks

Locate and repair refrigerant leaks and charge the unit as follows:

1. Use both high- and low-pressure ports to relieve system pressure and reclaim remaining refrigerant.
2. Repair leak following accepted practices.

NOTE: Install a bi-flow filter drier whenever the system has been opened for repair.

3. Check system for leaks using an approved method.
4. Evacuate refrigerant system and reclaim refrigerant if no additional leaks are found.
5. Charge unit with R-410A refrigerant, using a volumetric-charging cylinder or accurate scale. Refer to unit rating plate for required charge.

Step 2—Start-Up Adjustments

Complete the required procedures given in the Pre-Start-Up section before starting the unit. Do not jumper any safety devices when operating the unit. Do not operate the unit in Cooling mode when the outdoor temperature is below 40°F (unless accessory low-ambient kit is installed). Do not rapid-cycle the compressor. Allow 5 min. between "on" cycles to prevent compressor damage.

CHECKING COOLING AND HEATING CONTROL OPERATION

Start and check the unit for proper control operation as follows:

1. Place room thermostat SYSTEM switch or MODE control in OFF position. Observe that blower motor starts when FAN mode is placed in FAN ON position and shuts down within 60 sec (030-060 size) or 30 sec (024 size) when FAN MODE switch is placed in AUTO position.

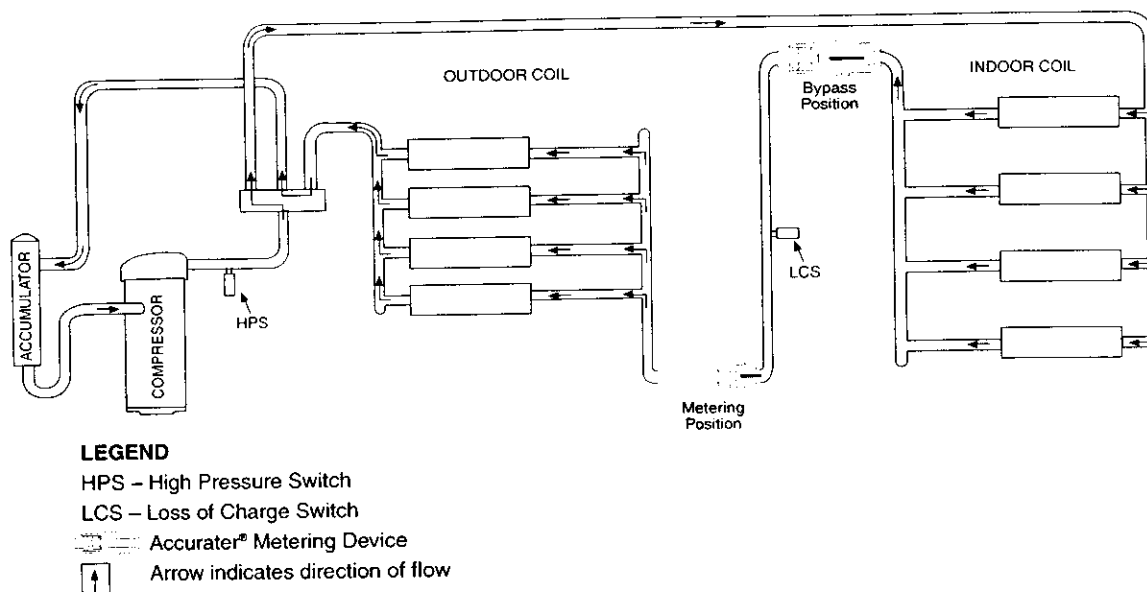

C00095

Fig. 22—Typical Heat Pump Operation, Heating Mode

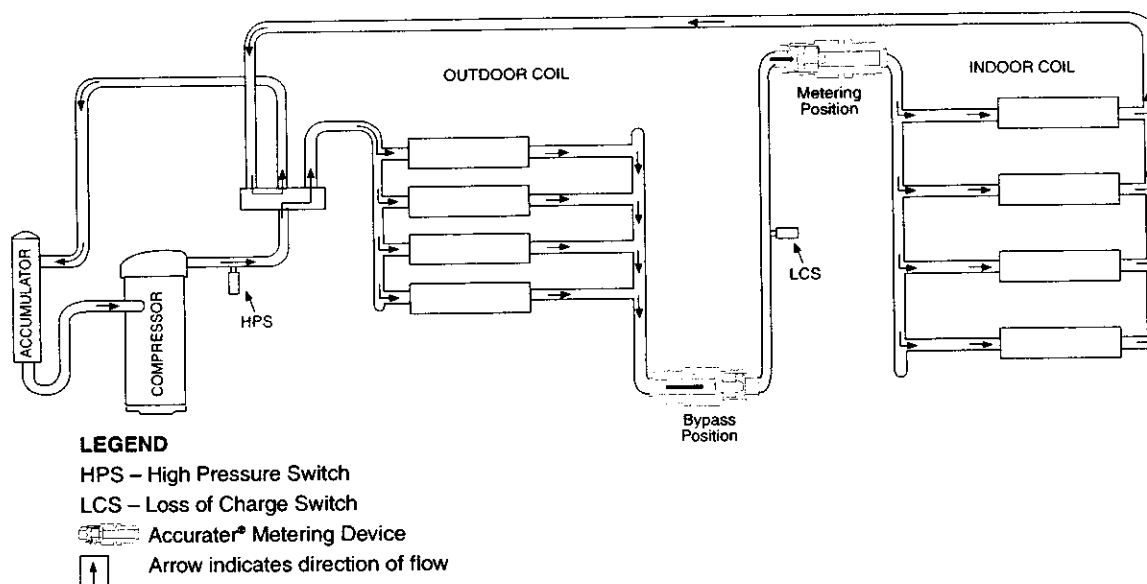

C00096

Fig. 23—Typical Heat Pump Operation, Cooling Mode

NOTE: If the problem causing the inaccurate readings is a refrigerant leak, refer to Check for Refrigerant Leaks section.

INDOOR AIRFLOW AND AIRFLOW ADJUSTMENTS

⚠ CAUTION

For heating and cooling operation, the recommended airflow is 350 to 450 cfm for each 12,000 Btuh of rated cooling capacity. For units with optional electric heat, the airflow must not be reduced below the levels stated in Table 2.

Table 4 shows both heating and cooling airflows at various external static pressures. Refer to these tables to determine the airflow for the system being installed.

NOTE: Be sure that all supply-and-return-air grilles are open, free from obstructions, and adjusted properly.

Airflow can be changed by changing the lead connection of the blower motor.

Unit 50JZ three-speed motors (except sizes 030 and 048) are factory wired for low speed operation. Units 50JZ 030 and 048 are factory wired for medium speed.

For 208/230-v Motors:— The motor leads are color-coded as follows:

- 3-SPEED
- Black = high speed
- Blue = medium speed
- Red = low speed

To change the speed of the blower motor (BM), remove the fan motor speed leg lead from the blower relay (BR). This wire is attached to IGC terminal BM for single-phase and 3-phase units. To change the speed, remove and replace with lead for desired blower motor speed. *Insulate the removed lead* to avoid contact with chassis parts.

For 460-v GE Motors—The motor leads are color coded as follows:

Table 4—Wet Coil Air Delivery
Unit 50JZ 024-060 (Deduct 10 percent for 208-v)*

UNIT	MOTOR SPEED		EXTERNAL STATIC PRESSURE (IN. WG)											
			0.0	0.1	0.2	0.3	0.4	0.5	0.6	0.7	0.8	0.9	1.0	
024	Low	Watts	275	273	271	270	-	-	-	-	-	-	-	-
		Cfm	923	844	754	669	-	-	-	-	-	-	-	-
	Med	Watts	-	-	-	359	353	350	347	341	-	-	-	-
		Cfm	-	-	-	941	876	814	737	622	-	-	-	-
	High	Watts	-	-	-	-	-	-	-	447	439	431	423	-
		Cfm	-	-	-	-	-	-	-	968	869	765	659	-
030	Low	Watts	276	276	272	-	-	-	-	-	-	-	-	-
		Cfm	963	929	781	-	-	-	-	-	-	-	-	-
	Med	Watts	375	377	371	362	354	350	-	-	-	-	-	-
		Cfm	1202	1170	1079	976	884	807	-	-	-	-	-	-
	High	Watts	-	-	-	-	469	449	435	428	-	-	-	-
		Cfm	-	-	-	-	1174	988	828	718	-	-	-	-
036	Low	Watts	462	451	431	411	394	381	-	-	-	-	-	
		Cfm	1374	1290	1205	1116	1020	916	-	-	-	-	-	
	Med	Watts	523	506	490	471	449	426	-	-	-	-	-	
		Cfm	1500	1408	1301	1190	1082	977	-	-	-	-	-	
	High	Watts	-	645	628	610	595	584	575	-	-	-	-	
		Cfm	-	1474	1369	1267	1169	1069	962	-	-	-	-	
042	Low	Watts	660	639	524	611	598	583	564	541	518	495	473	
		Cfm	1701	1659	1618	1576	1531	1481	1425	1363	1293	1223	1154	
	Med	Watts	-	-	-	-	-	704	675	645	614	582	550	
		Cfm	-	-	-	-	-	1701	1631	1550	1460	1361	1256	
	High	Watts	-	-	-	-	-	-	-	806	777	749	726	
		Cfm	-	-	-	-	-	-	-	1708	1614	1521	1435	
048	Low	Watts	620	600	586	574	562	548	530	510	487	-	-	
		Cfm	1662	1621	1581	1540	1496	1447	1392	1331	1263	-	-	
	Med	Watts	763	747	729	709	686	661	634	606	577	547	517	
		Cfm	1917	1868	1822	1774	1722	1662	1594	1515	1427	1330	1227	
	High	Watts	-	-	-	852	832	809	784	757	730	704	682	
		Cfm	-	-	-	1982	1914	1839	1757	1669	1577	1486	1402	
060	Low	Watts	597	592	578	526	460	452	445	-	-	-	-	
		Cfm	2265	2190	2101	2033	1974	1869	1614	-	-	-	-	
	Med	Watts	754	730	707	687	671	658	646	630	603	558	486	
		Cfm	2383	2282	2202	2134	2070	2005	1935	1858	1771	1667	1576	
	High	Watts	901	876	856	836	813	785	755	723	696	681	687	
		Cfm	2480	2383	2301	2233	2175	2122	2066	1998	1910	1788	1619	

* Air delivery values are based on operating voltage of 230-v or 460-v, wet coil, without filter or electric heater. Deduct filter and electric heater pressure drop (see Tables 5 and 6) to obtain static pressure available for ducting.

NOTES:

1. Do not operate the unit at a cooling airflow that is less than 350 cfm for each 12,000 Btuh of rated cooling capacity. Evaporator coil frosting may occur at airflows below this point.
2. Dashes indicate portions of table that are beyond the blower motor capacity or are not recommended.
3. Deduct 10 percent for 208-v.

Table 5—FILTER PRESSURE DROP TABLE (In. wg)

FILTER SIZE	CFM																		
	500	600	700	800	900	1000	1100	1200	1300	1400	1500	1600	1700	1800	1900	2000	2100	2200	2300
20 X 20 X 1	0.05	0.07	0.08	0.10	0.12	0.13	0.14	0.15	—	—	—	—	—	—	—	—	—	—	—
20 X 24 X 1	—	—	—	—	0.09	0.10	0.11	0.13	0.14	0.15	0.16	—	—	—	—	—	—	—	—
24 X 30 X 1	—	—	—	—	—	—	—	0.07	0.08	0.09	0.10	0.11	0.12	0.13	0.14	0.15	0.16	0.17	0.18

3-SPEED

- Black = high
- Violet = jumper
- Orange = medium
- Red = low

To change the speed of the blower motor (BM), remove fan motor speed lead from the blower relay (BR) and replace with the lead for the desired blower motor speed. The motor speed lead is

attached to terminal BM. For low and medium speeds, black must be connected to the jumper wire. Insulate removed lead end to avoid contact with chassis parts. To select high speed on 460-v GE motors, separate the black female quick connect (QC) from the jumper lead male quick connect (QC) and connect the black lead to the BR. Insulate the jumper to avoid contact with any chassis parts.

→ **Table 6—ELECTRIC HEAT PRESSURE DROP TABLE**
Small Cabinet: 024-036CFM

	500	600	700	800	900	1000	1100	1200	1300	1400	1500	1600
5 kW	0.00	0.00	0.00	0.00	0.00	0.00	0.00	0.00	0.02	0.04	0.06	0.07
10 kW	0.00	0.00	0.00	0.00	0.00	0.02	0.04	0.06	0.07	0.09	0.10	0.11
15 kW	0.00	0.00	0.00	0.02	0.04	0.06	0.08	0.10	0.12	0.14	0.16	0.18
20 kW	0.00	0.00	0.02	0.04	0.06	0.08	0.09	0.11	0.13	0.15	0.17	0.19

ELECTRIC HEAT PRESSURE DROP TABLE
Large Cabinet: 042-060
CFM

	1100	1200	1300	1400	1500	1600	1700	1800	1900	2000	2100	2200	2300	2400	2500
5 kW	0.00	0.00	0.00	0.01	0.02	0.03	0.04	0.05	0.06	0.07	0.08	0.09	0.10	0.11	0.12
10 kW	0.00	0.00	0.01	0.02	0.03	0.04	0.05	0.06	0.07	0.08	0.09	0.10	0.11	0.12	0.13
15 kW	0.00	0.02	0.03	0.04	0.05	0.06	0.07	0.08	0.09	0.10	0.11	0.12	0.13	0.14	0.15
20 kW	0.02	0.03	0.04	0.05	0.06	0.07	0.08	0.09	0.10	0.11	0.12	0.13	0.14	0.15	0.16

Balance Point Worksheet

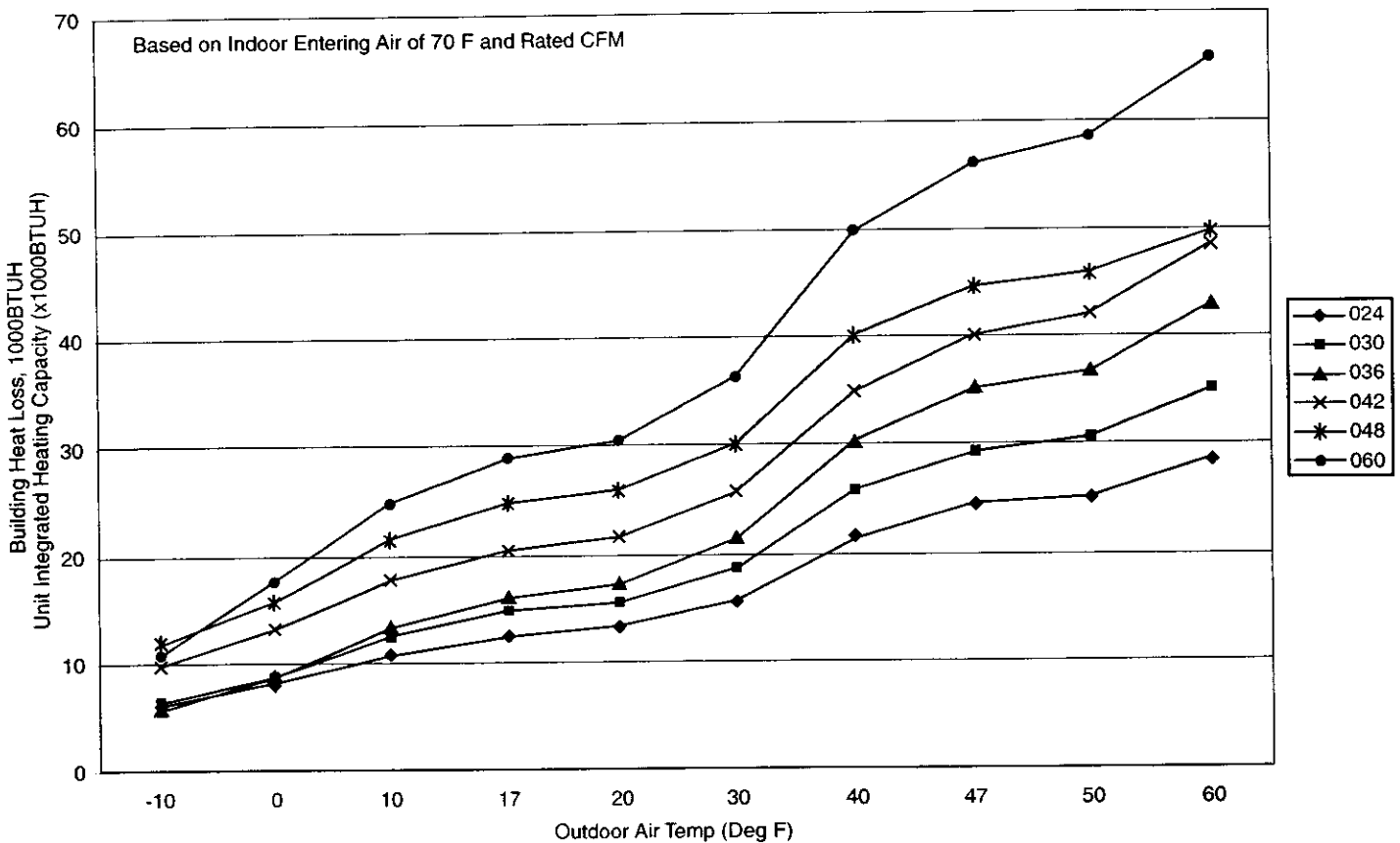

Fig. 24—50JZ Balance Point Worksheet

Step 3—Defrost Control

QUIET SHIFT

Quiet Shift is a field-selectable defrost mode, which will eliminate occasional noise that could be heard at the start of defrost cycle and restarting of heating cycle. It is selected by placing DIP switch 3 (on defrost board) in ON position.

When Quiet Shift switch is placed in ON position, and a defrost is initiated, the following sequence of operation will occur. Revers-

ing valve will energize, outdoor fan will turn off, compressor will turn off for 30 sec and then turn back on to complete defrost. At the start of heating after conclusion of defrost reversing valve will de-energize, compressor will turn off for another 30 sec, and the outdoor fan will stay off for 40 sec, before starting in the Heating mode.

C00138

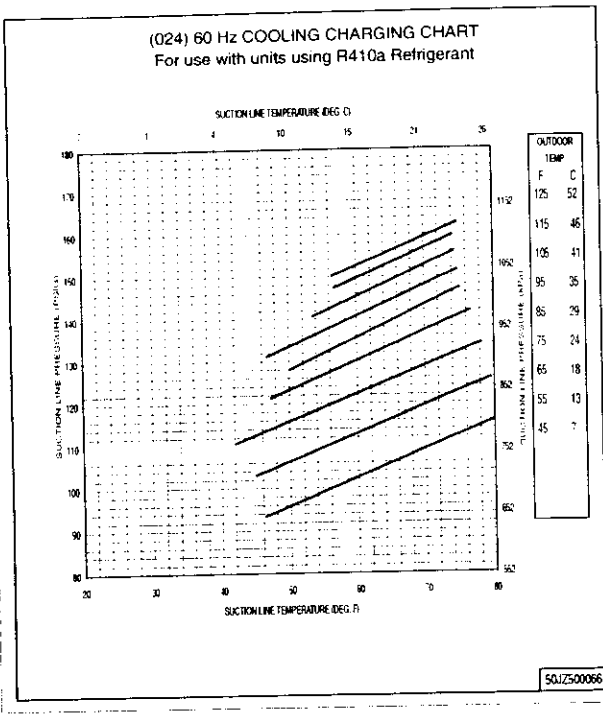

Fig. 25—Cooling Charging Chart, 50JZ 024 Units C00082

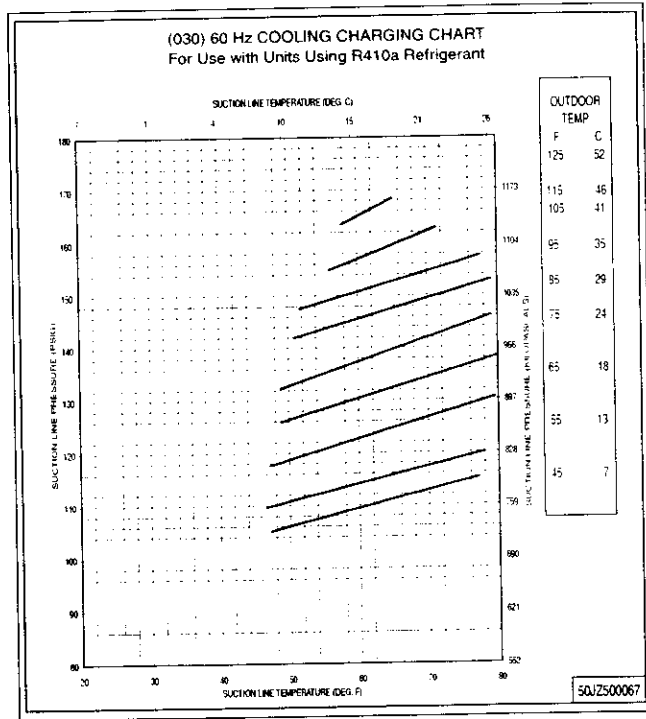

Fig. 26—Cooling Charging Chart, 50JZ 030 Units C00083

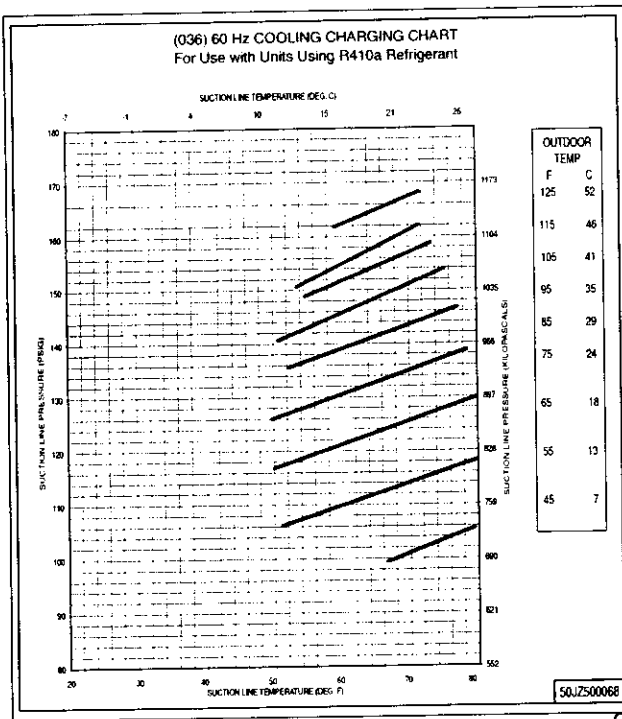

Fig. 27—Cooling Charging Chart, 50JZ 036 Units C00084

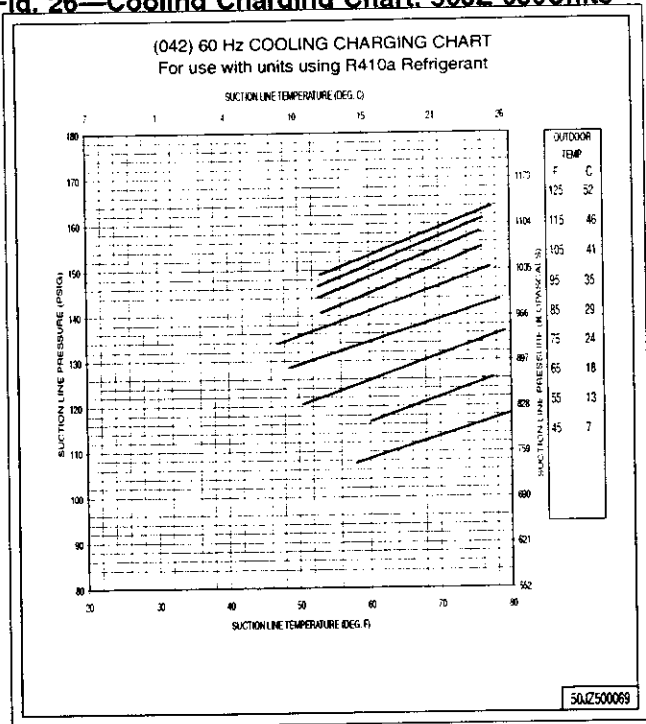

Fig. 28—Cooling Charging Chart, 50JZ 042 Units C00085

DEFROST

The defrost control is a time/temperature control which includes a field-selectable time period (DIP switch 1 and 2 on the board) between defrost cycles of 30, 60, 90, or 120 minutes (factory set at 30 minutes).

To initiate a forced defrost, two options are available depending on the status of the defrost thermostat.

If defrost thermostat is closed, speedup pins (J1) must be shorted by placing a flat head screw driver in between for 5 sec and releasing, to observe a complete defrost cycle. When the Quiet

Shift switch is selected, compressor will be turned off for two 30 sec intervals during this complete defrost cycle, as explained previously. When Quiet Shift switch is in factory default OFF position, a normal and complete defrost cycle will be observed.

If defrost thermostat is in open position, and speedup pins are shorted (with a flat head screw driver) for 5 sec and released, a short defrost cycle will be observed (actual length is dependent upon the selected Quiet Shift position). When Quiet Shift switch is in ON position, the length of defrost is 1 minute (30 sec compressor off period followed by 30 sec of defrost with compressor operation). On return to heating operation, compressor will

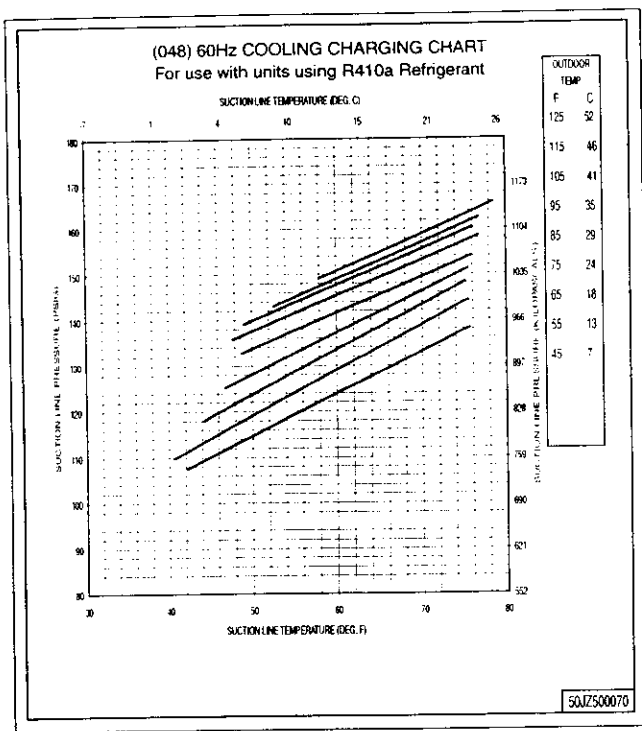

Fig. 29—Cooling Charging Chart, 50JZ 048 Units C00086

again turn off for an additional 30 sec and the outdoor fan for 40 sec. When the Quiet Shift is in OFF position, only a brief 30 sec cycle will be observed.

If it is desirable to observe a complete defrost in warmer weather, the defrost thermostat must be closed as follows.

1. Turn off power to outdoor unit.
2. Disconnect outdoor fan motor lead from OF2 on control board (See Fig. 19). Tape to prevent grounding.
3. Restart unit in Heating mode, allowing frost to accumulate on outdoor coil.
4. After a few minutes in Heating mode, liquid line temperature should drop below closing point of defrost thermostat (approximately 30°F).

NOTE: Unit will remain in defrost until defrost thermostat reopens at approximately 80°F coil temperature at liquid line or remainder of defrost cycle time.

5. Turn off power to outdoor and reconnect fan motor lead to OF2 on control board after above forced defrost cycle.

MAINTENANCE

To ensure continuing high performance, and to minimize the possibility of premature equipment failure, periodic maintenance must be performed on this equipment. This heat pump unit should be inspected at least once each year by a qualified service person. To troubleshoot unit, refer to Table 7.

NOTE TO EQUIPMENT OWNER: Consult your local dealer about the availability of a maintenance contract.

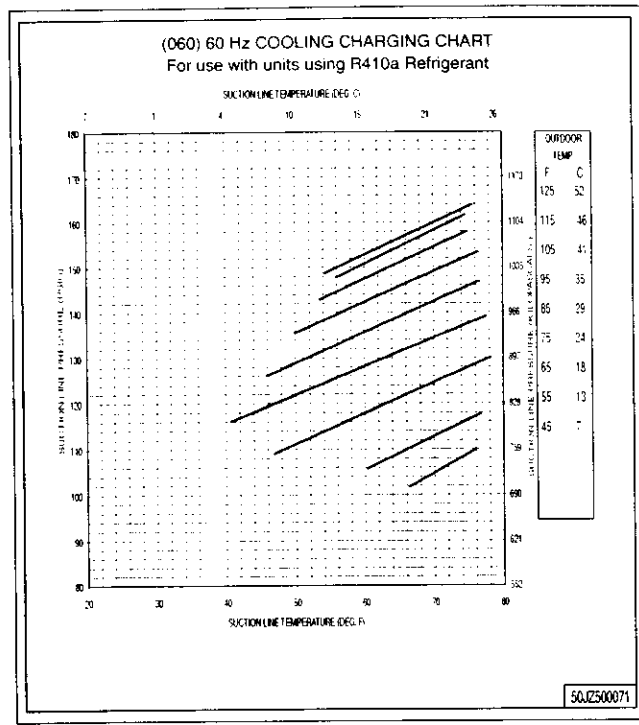

Fig. 30—Cooling Charging Chart, 50JZ 060 Units C00087

⚠ WARNING

The ability to properly perform maintenance on this equipment requires certain expertise, mechanical skills, tools and equipment. If you do not possess these, do not attempt to perform any maintenance on this equipment, other than those procedures recommended in the User's Manual. **FAILURE TO HEED THIS WARNING COULD RESULT IN SERIOUS INJURY OR DEATH AND POSSIBLE DAMAGE TO THIS EQUIPMENT.**

⚠ WARNING

Failure to follow these warnings could result in serious injury or death:

1. Turn off electrical power to the unit before performing any maintenance or service on this unit.
2. Use extreme caution when removing panels and parts. As with any mechanical equipment, personal injury can result from sharp edges.
3. Never place anything combustible either on, or in contact with, the unit.

⚠ CAUTION

Errors made when reconnecting wires may cause improper and dangerous operation. Label all wires prior to disconnecting when servicing.

The minimum maintenance requirements for this equipment are as follows:

1. Inspect air filter(s) each month. Clean or replace when necessary.
2. Inspect indoor coil, drain pan, and condensate drain each cooling season for cleanliness. Clean when necessary.
3. Inspect blower motor and wheel for cleanliness each cooling season. Clean when necessary.

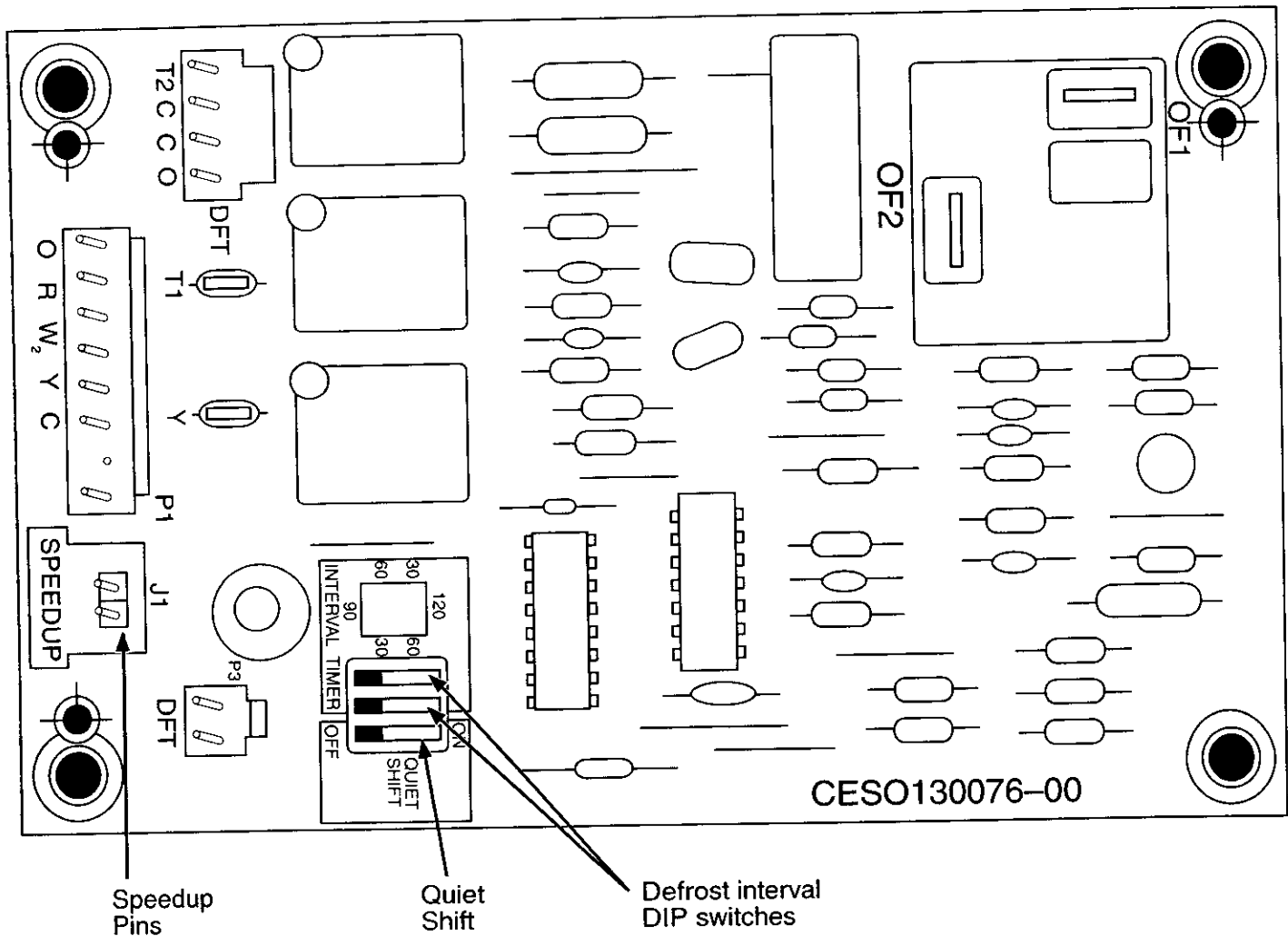

A99442

Fig. 31—Defrost Control

4. Check electrical connections for tightness and controls for proper operation each cooling season. Service when necessary.

Step 1—Air Filter

IMPORTANT: Never operate the unit without a suitable air filter in the return-air duct system. Always replace the filter with the same dimensional size and type as originally installed. See Table 1 for recommended filter sizes.

Inspect air filter(s) at least once each month and replace (throwaway-type) or clean (cleanable-type) at least twice during each cooling season and twice during the heating season, or whenever the filter becomes clogged with dust and lint.

Step 2—Indoor Blower and Motor

NOTE: All motors are prelubricated. Do not attempt to lubricate these motors.

For longer life, operating economy, and continuing efficiency, clean accumulated dirt and grease from the blower wheel and motor annually.

⚠ WARNING

Disconnect and tag electrical power to the unit before cleaning and lubricating the blower motor and wheel. Failure to adhere to this warning could cause personal injury or death.

Step 3—Outdoor Coil, Indoor Coil, and Condensate Drain Pan

Inspect the condenser coil, evaporator coil, and condensate drain pan at least once each year.

The coils are easily cleaned when dry; therefore, inspect and clean the coils either before or after each cooling season. Remove all obstructions, including weeds and shrubs, that interfere with the airflow through the condenser coil.

Straighten bent fins with a fin comb. If coated with dirt or lint, clean the coils with a vacuum cleaner, using the soft brush attachment. Be careful not to bend the fins. If coated with oil or grease, clean the coils with a mild detergent-and-water solution. Rinse coils with clear water, using a garden hose. Be careful not to splash water on motors, insulation, wiring, or air filter(s). For best results, spray condenser coil fins from inside to outside the unit. On units with an outer and inner condenser coil, be sure to clean between the coils. Be sure to flush all dirt and debris from the unit base.

Inspect the drain pan and condensate drain line when inspecting the coils. Clean the drain pan and condensate drain by removing all foreign matter from the pan. Flush the pan and drain trough with

clear water. Do not splash water on the insulation, motor, wiring, or air filter(s). If the drain trough is restricted, clear it with a "plumbers snake" or similar probe device.

Step 4—Outdoor Fan

⚠ CAUTION

Keep the condenser fan free from all obstructions to ensure proper cooling operation. Never place articles on top of the unit. Damage to unit may result.

1. Remove 6 screws holding outdoor grille and motor to top cover.
2. Turn motor/grille assembly upside down on top cover to expose fan blade.
3. Inspect the fan blades for cracks or bends.
4. If fan needs to be removed, loosen setscrew and slide fan off motor shaft.
5. When replacing fan blade, position blade so that the hub is 1/8 in. away from the motor end (1/8 in. of motor shaft will be visible) (See Fig. 21).
6. Ensure that setscrew engages the flat area on the motor shaft when tightening.
7. Replace grille.

Step 5—Electrical Controls and Wiring

Inspect and check the electrical controls and wiring annually. *Be sure to turn off the electrical power to the unit.*

Remove access panel to locate all the electrical controls and wiring. Check all electrical connections for tightness. Tighten all screw connections. If any smoky or burned connections are noticed, disassemble the connection, clean all the parts, restrip the wire end and reassemble the connection properly and securely.

After inspecting the electrical controls and wiring, replace all the panels. Start the unit, and observe at least one complete cooling cycle to ensure proper operation. If discrepancies are observed in operating cycle, or if a suspected malfunction has occurred, check each electrical component with the proper electrical instrumentation. Refer to the unit wiring label when making these checkouts.

Step 6—Refrigerant Circuit

Inspect all refrigerant tubing connections and the unit base for oil accumulation annually. Detecting oil generally indicates a refrigerant leak.

If oil is detected or if low performance is suspected, leak-test all refrigerant tubing using an electronic leak detector, or liquid-soap solution. If a refrigerant leak is detected, refer to Check for Refrigerant Leaks section.

If no refrigerant leaks are found and low performance is suspected, refer to Checking and Adjusting Refrigerant Charge section.

Step 7—Indoor Airflow

The heating and/or cooling airflow does not require checking unless improper performance is suspected. *If a problem exists, be sure that all supply- and return-air grilles are open and free from obstructions, and that the air filter is clean.* When necessary, refer to Indoor Airflow and Airflow Adjustments section to check the system airflow.

Step 8—Metering Devices—Accurater Piston

This metering device is a fixed orifice and is contained in the brass hex-body in the liquid line feeding the indoor and outdoor coils.

Step 9—Pressure Switches

Pressure switches are protective devices wired into control circuit (low voltage). They shut off compressor if abnormally high or low

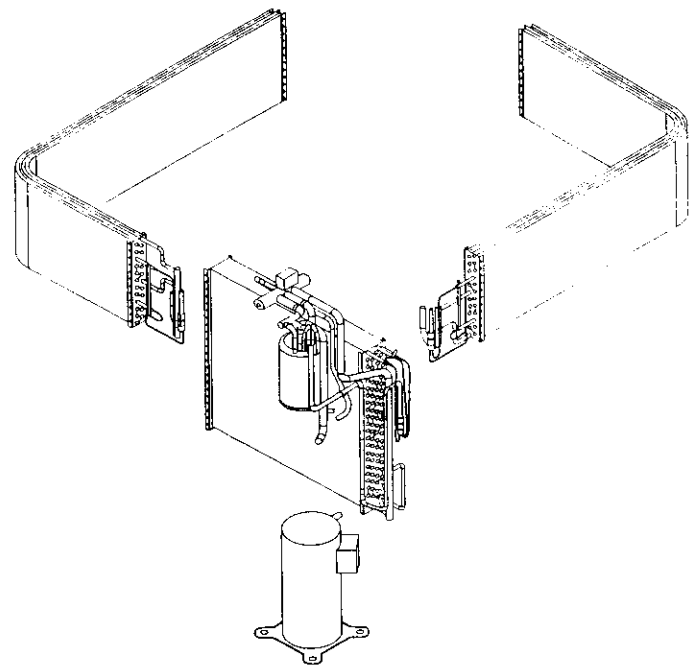

C99097

Fig. 32—Refrigerant Circuit

pressures are present in the refrigeration circuit. These pressure switches are specifically designed to operate with Puron (R-410A) systems. R-22 pressure switches **must not** be used as replacements for the Puron (R-410A) system.

Step 10—Loss of Charge Switch

This switch is located on the liquid line and protects against low suction pressures caused by such events as loss of charge, low airflow across indoor coil, dirty filters, etc. It opens on a pressure drop at about 20 psig. If system pressure is above this, switch should be closed. To check switch:

1. Turn off all power to unit.
2. Disconnect leads on switch.
3. Apply ohm meter leads across switch. You should have continuity on a good switch.

NOTE: Because these switches are attached to refrigeration system under pressure, it is not advisable to remove this device for troubleshooting unless you are reasonably certain that a problem exists. If switch must be removed, remove and recover all system charge so that pressure gauges read 0 psi. Never open system without breaking vacuum with dry nitrogen.

Step 11—High-Pressure Switch

The high-pressure switch is located in the discharge line and protects against excessive condenser coil pressure. It opens at 610 psig.

High pressure may be caused by a dirty outdoor coil, failed fan motor, or outdoor air recirculation.

To check switch:

1. Turn off all power to unit.
2. Disconnect leads on switch.
3. Apply ohm meter leads across switch. You should have continuity on a good switch.

Step 12—Copeland Scroll Compressor (Puron Refrigerant)

The compressor used in this product is specifically designed to operate with Puron (R-410A) refrigerant and cannot be interchanged.

The compressor is an electrical (as well as mechanical) device. Exercise extreme caution when working near compressors. Power should be shut off, if possible, for most troubleshooting techniques. Refrigerants present additional safety hazards.

▲ WARNING

Wear safety glasses and gloves when handling refrigerants. Keep torches and other ignition sources away from refrigerants and oils. Failure to follow this warning can cause a fire, serious injury, or death.

The scroll compressor pumps refrigerant throughout the system by the interaction of a stationary and an orbiting scroll. The scroll compressor has no dynamic suction or discharge valves, and it is more tolerant of stresses caused by debris, liquid slugging, and flooded starts. The compressor is equipped with an anti-rotational device and an internal pressure relief port. The anti-rotational device prevents the scroll from turning backwards and replaces the need for a cycle protector. The pressure relief port is a safety device, designed to protect against extreme high pressure. The relief port has an operating range between 550 and 625 psi differential pressure.

The Copeland scroll compressor uses Mobil 3MA POE oil. This is the only oil allowed for oil recharge.

Step 13—Refrigerant System

This step covers the refrigerant system of the 50JZ, including the compressor oil needed, servicing systems on roofs containing synthetic materials, the filter drier and refrigerant charging.

REFRIGERANT

▲ CAUTION

This system uses Puron (R-410A) refrigerant which has higher operating pressures than R-22 and other refrigerants. No other refrigerant may be used in this system. Gauge set, hoses, and recovery system must be designed to handle Puron. If you are unsure consult the equipment manufacturer. Failure to use Puron compatible servicing equipment or replacement components may result in property damage or injury.

COMPRESSOR OIL

The compressor in this system uses a polyolester (POE) oil, Mobil 3MA POE. This oil is extremely hygroscopic, meaning it absorbs water readily. POE oils can absorb 15 times as much water as other oils designed for HCFC and CFC refrigerants. Take all necessary precautions to avoid exposure of the oil to the atmosphere.

SERVICING SYSTEMS ON ROOFS WITH SYNTHETIC MATERIALS

POE (polyolester) compressor lubricants are known to cause long term damage to some synthetic roofing materials.

Exposure, even if immediately cleaned up, may cause embrittlement (leading to cracking) to occur in one year or more. When performing any service that may risk exposure of compressor oil to the roof, take appropriate precautions to protect roofing. Procedures which risk oil leakage include, but are not limited to, compressor replacement, repairing refrigerant leaks, replacing refrigerant components such as filter drier, pressure switch, metering device, coil, accumulator, or reversing valve.

Synthetic Roof Precautionary Procedure

1. Cover extended roof working area with an impermeable polyethylene (plastic) drip cloth or tarp. Cover an approximate 10 x 10 ft. area.

2. Cover area in front of the unit service panel with a terry cloth shop towel to absorb lubricant spills and prevent run-offs, and protect drop cloth from tears caused by tools or components.
3. Place terry cloth shop towel inside unit immediately under component(s) to be serviced and prevent lubricant run-offs through the louvered openings in the base pan.
4. Perform required service.
5. Remove and dispose of any oil contaminated material per local codes.

LIQUID LINE FILTER DRIER

The biflow filter drier is specifically designed to operate with Puron. Use only factory-authorized components. Filter drier must be replaced whenever the refrigerant system is opened. When removing a filter drier, use a tubing cutter to cut the drier from the system. **Do not unsweat a filter drier from the system.** Heat from unsweating will release moisture and contaminants from drier into system.

PURON (R-410A) REFRIGERANT CHARGING

Refer to unit information plate and charging chart. **Some R-410A refrigerant cylinders contain a dip tube to allow liquid refrigerant to flow from cylinder in upright position.** For cylinders equipped with a dip tube, charge Puron units with cylinder in upright position and a commercial metering device in manifold hose. Charge refrigerant into suction-line.

Step 14—System Information

TIME-DELAY RELAY

The Time-Delay Relay (TDR) is a solid-state control, recycle delay timer which keeps indoor blower operating for 60 sec on 030-060 sizes or 30 sec on 024 size after thermostat is satisfied. This delay enables blower to remove residual cooling in coil after compression shutdown, thereby improving efficiency of system. The sequence of operation is that on closure of wall thermostat and at end of a fixed on delay of 1 sec, fan relay is energized. When thermostat is satisfied, an off delay is initiated. When fixed delay of 60 ± 5 sec or 30 ± 5 sec is completed, fan relay is de-energized and fan motor stops. If wall thermostat closes during this delay, TDR is reset and fan relay remains energized. TDR is a 24v device that operates within a range of 15v to 30v and draws about 0.5 amps. If the blower runs continuously instead of cycling off when the fan switch is set on AUTO, the TDR is probably defective and must be replaced.

LOSS OF CHARGE SWITCH

The loss of charge switch is a protective device wired into control circuit (low voltage). It shuts off the compressor if abnormally low pressures are present in the refrigeration circuit.

NOTE: Because these switches are attached to refrigeration system under pressure, it is not advisable to remove this device for troubleshooting unless you are reasonably certain that a problem exists. If switch must be removed, remove and recover all system charge so that pressure gauges read 0 psi. Never open system without breaking vacuum with dry nitrogen.

CHECK DEFROST THERMOSTAT

There is a liquid header with a brass distributor and feeder tube going into outdoor coil. At the end of 1 of the feeder tubes, there is a 3/8-in. OD stub tube approximately 3 in. long (See Fig. 33). The defrost thermostat should be located on stub tube. Note that there is only 1 stub tube used with liquid header, and on most units it is the bottom circuit.

The defrost thermostat signals heat pump that conditions are right for defrost or that conditions have changed to terminate defrost. It

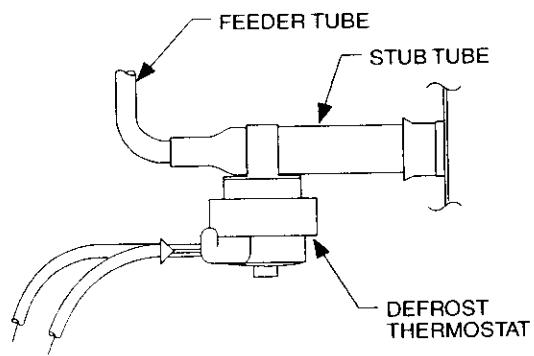

C99029

Fig. 33—Defrost Thermostat

is a thermally actuated switch clamped to outdoor coil to sense its temperature. Normal temperature range is closed at $30^{\circ} \pm 3^{\circ}\text{F}$ and open at $80^{\circ} \pm 5^{\circ}\text{F}$.

NOTE: The defrost thermostat must be located on the liquid side of the outdoor coil on the bottom circuit and as close to the coil as possible.

TROUBLESHOOTING

Refer to the Cooling and Heating Troubleshooting Chart (See Table 7.) for troubleshooting information.

START-UP CHECKLIST

Use the Start-Up checklist to ensure proper start-up procedures are followed.

HEAT PUMP WITH PURON—QUICK REFERENCE GUIDE

Puron refrigerant operates at 50-70 percent higher pressures than R-22. Be sure that servicing equipment and replacement components are designed to operate with Puron. Puron refrigerant cylinders are rose colored.

- Puron refrigerant cylinders manufactured prior to March 1, 1999, have a dip tube that allows liquid to flow out of cylinder in upright position. Cylinders manufactured March 1, 1999 and later DO NOT have a dip tube and MUST be positioned upside down to allow liquid to flow.
- Recovery cylinder service pressure rating must be 400 psig. DOT 4BA400 or DOT BW400.
- Puron systems should be charged with liquid refrigerant. Use a commercial type metering device in the manifold hose.
- Manifold sets should be 750 psig high-side and 200 psig low-side with 520 psig low-side retard.
- Use hoses with 750 psig service pressure rating.
- Leak detectors should be designed to detect HFC refrigerant.
- Puron, as with other HFCs, is only compatible with POE oils.
- Vacuum pumps will not remove moisture from oil.
- Only use factory specified liquid-line filter driers with rated working pressures no less than 600 psig.
- Do not install a suction-line filter drier in liquid line.
- POE oils absorb moisture rapidly. Do not expose oil to atmosphere.
- POE oils may cause damage to certain plastics and roofing materials.
- Wrap all filter driers and service valves with wet cloth when brazing.
- A Puron liquid-line filter drier is required on every unit.
- Do not use an R-22 TXV.
- **Never** open system to atmosphere while it is under a vacuum.
- When system must be opened for service, break vacuum with dry nitrogen and replace filter driers.
- Do not vent Puron into the atmosphere.
- Observe all **warnings, cautions, and bold text**.
- Do not leave Puron suction line driers in place for more than 72 hrs.

Table 7—Troubleshooting Chart

SYMPTOM	CAUSE	REMEDY
Compressor and outdoor fan will not start	Power Failure	Call power company
	Fuse blown or circuit breaker tripped	Replace fuse or reset circuit breaker
	Defective thermostat, contactor, transformer, control relay, defrost board, or high pressure or loss-of-charge/low pressure switch	Replace component
	Insufficient line voltage	Determine cause and correct
	Incorrect or faulty wiring	Check wiring diagram and rewire correctly
	Thermostat setting too high	Lower thermostat setting below room temperature
	Units have a 5-minute time delay	DO NOT bypass this compressor time delay—wait for 5 minutes until time-delay relay is deenergized
Compressor will not start but condenser fan runs	Faulty wiring or loose connections in compressor circuit	Check wiring and repair or replace
	Compressor motor burned out, seized, or internal overload open	Determine cause. Replace compressor
	Defective run capacitor, overload, or PTC (positive temperature coefficient) thermistor	Determine cause and replace
	One leg of 3-phase power dead	Replace fuse or reset circuit breaker. Determine cause
	Low input voltage (20 percent low)	Determine cause and correct
Three-phase scroll compressor (size 030-060 units) may be a low pressure differential	Scroll compressor is rotating in the wrong direction	Correct the direction of rotation by reversing the 3-phase power leads to the unit
Compressor cycles (other than normally satisfying thermostat)	Refrigerant overcharge or undercharge	Recover refrigerant, evacuate system, and recharge to capacities shown on nameplate
	Defective compressor	Replace and determine cause
	Insufficient line voltage	Determine cause and correct
	Blocked outdoor coil	Determine cause and correct
	Defective run/start capacitor, overload or start relay	Determine cause and replace
	Defective thermostat	Replace thermostat
	Faulty outdoor-fan motor or capacitor	Replace
	Damaged reversing valve	Determine cause and correct
	Restriction in refrigerant system	Locate restriction and remove
Compressor operates continuously	Dirty air filter	Replace filter
	Unit undersized for load	Decrease load or increase unit size
	Thermostat set too low	Reset thermostat
	Low refrigerant charge	Locate leak, repair, and recharge
	Frosted coil with incorrect defrost operation	Check defrost time settings Reset as necessary Check defrost temperature switch Replace as necessary
	Air in system	Recover refrigerant, evacuate system, and recharge
	Outdoor coil dirty or restricted	Clean coil or remove restriction
	Dirty air filter	Replace filter
Excessive head pressure	Dirty indoor or outdoor coil	Clean coil
	Refrigerant overcharged	Recover excess refrigerant
	Air in system	Recover refrigerant, evacuate system, and recharge
	(Heat) Indoor air restricted or recirculating	Determine cause and correct
	Indoor or outdoor air restricted or air short-cycling	Determine cause and correct

(Continued next page)

Table 7—Troubleshooting Chart (Cont'd)

SYMPTOM	CAUSE	REMEDY
Head pressure too low	Low refrigerant charge	Check for leaks, repair and recharge
	Restriction in liquid tube	Remove restriction
Excessive suction pressure	(Heat) Outdoor coil frosted	Move timer on control board to 30 minutes between defrost cycles
	(Cool) High Heat load	Check for source and eliminate
	Reversing valve hung up or leaking internally	Replace valve
	Refrigerant overcharged	Recover excess refrigerant
Suction pressure too low	(Cool) Dirty air filter	Replace filter
	(Heat) Outdoor coil frosted	Move timer on control board to 30 minutes between defrost cycles
	Low refrigerant charge	Check for leaks, repair and recharge
	Metering device or low side restricted	Remove source of restriction
	(Cool) Insufficient coil airflow	Increase air quantity Check filter—replace if necessary
	(Cool) Temperature too low in conditioned area	Reset thermostat
	(Cool) Outdoor ambient below 40°F	Install low-ambient kit
	Filter-drier restricted	Replace
Compressor runs but outdoor fan does not	NC (normally closed) contacts on defrost board open	Check condition of relay on board Replace if necessary
IFM does not run	Blower wheel not secured to shaft	Properly tighten blower wheel to shaft
	Insufficient voltage at motor	Determine cause and correct
	Power connectors not properly sealed	Connectors should snap easily; do not force
IFM operation is intermittent	Water dripping into motor	Verify proper drip loops in connector wires
	Connectors not firmly sealed	Gently pull wires individually to be sure they are crimped into the housing

IFM—Indoor Fan Motor

**START-UP CHECKLIST
(REMOVE AND STORE IN JOB FILE)**

I. PRELIMINARY INFORMATION

Model No
Serial No
Date
Technician

II. PRE-START-UP

- Verify that all packing materials have been removed from unit
- Remove all shipping holddown bolts and brackets per installation instructions
- Make sure that – on the 060 size, only – the two wire ties fastened to the outdoor coils and reversing valve/accumulator have been removed
- Verify that condensate connection is installed per installation instructions
- Check all electrical connections and terminals for tightness
- Check that indoor (evaporator) air filter is clean and in place
- Verify that unit installation is level
- Check fan wheel propeller for location in housing and setscrew tightness

III. START-UP

Supply Voltage: L1-L2 _____ L2-L3 _____ L3-L1 _____
Compressor Amps: L1 _____ L2 _____ L3 _____
Indoor Fan Amps: _____

AIR TEMPERATURE

Outdoor-Air Temperature: _____ DB
Return-Air Temperature: _____ DB _____ WB
Heat Pump Supply Air: _____
Electric Heater Supply Air: _____

REFRIGERANT PRESSURES AND TEMPERATURES

Refrigerant Suction _____ psig
Refrigerant Discharge _____ psig
Suction Line Temp* _____
Discharge Line Temp† _____
Liquid Line Temp‡ _____
 Verify Refrigerant charge using charging tables
 Verify that 3-phase scroll compressor is rotating in correct direction.

* Measured at suction inlet to compressor

† Measured at discharge outlet from compressor.

‡ Measured at liquid line leaving condenser

Manufacturer reserves the right to discontinue, or change at any time, specifications or designs without notice and without incurring obligations.