

# WEIDER<sup>®</sup> PRO 575.

## USER'S MANUAL

Model No. 831.153230

Serial No. \_\_\_\_\_

Write the serial number in the space above for future reference.

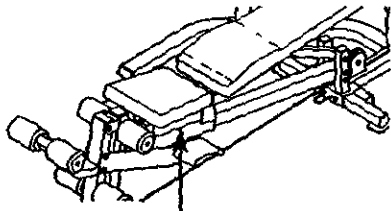

Serial Number Decal (Under Seat)

EXERCISE  
EQUIPMENT

QUESTIONS

HELPLINE!

1-800-736-6879

SEARS, ROEBUCK AND CO.,  
HOFFMAN ESTATES, IL 60179

### CAUTION

Read all precautions and instructions in this manual before using this equipment. Save this manual for future reference.

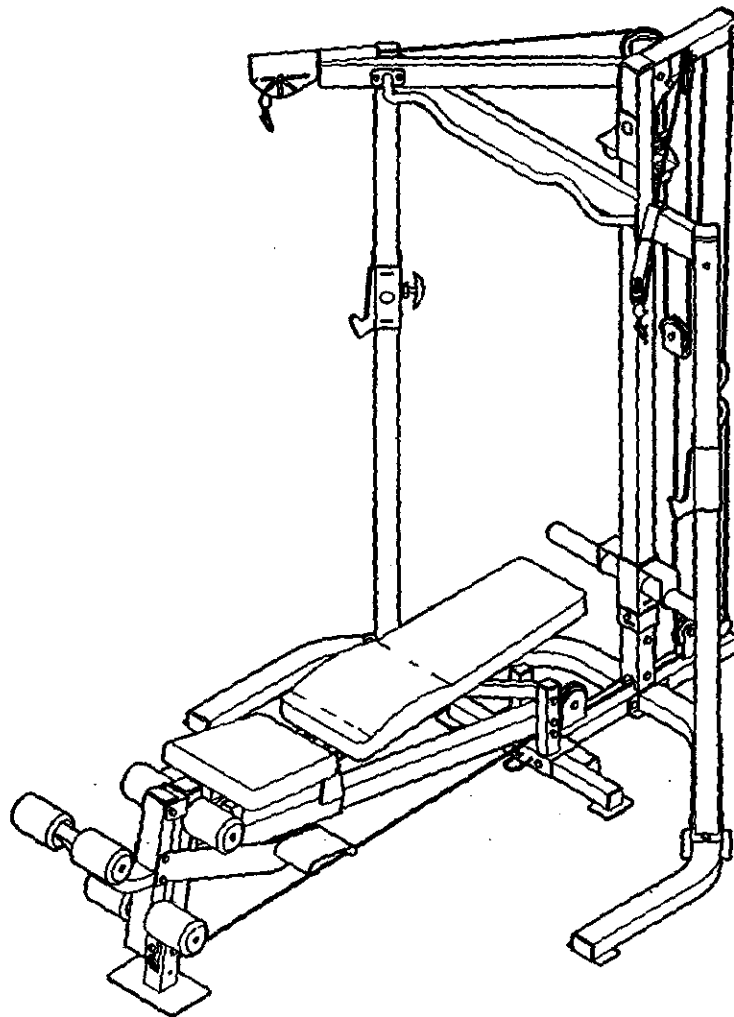

Visit our website at

[www.weiderfitness.com](http://www.weiderfitness.com)

new products, prizes,  
fitness tips, and much more!

# TABLE OF CONTENTS

WARNING DECAL PLACEMENT .....	2
IMPORTANT PRECAUTIONS .....	3
BEFORE YOU BEGIN .....	4
PART IDENTIFICATION CHART .....	5
ASSEMBLY .....	6
CABLE DIAGRAM .....	16
ADJUSTMENTS .....	17
BENCH ADJUSTMENT CHART .....	20
EXERCISE GUIDELINES .....	21
ORDERING REPLACEMENT PARTS .....	Back Cover
FULL 90 DAY WARRANTY .....	Back Cover

Note: A PART LIST/EXPLODED DRAWING is attached in the center of this manual. Remove the PART LIST/EXPLODED DRAWING before beginning assembly.

## WARNING DECAL PLACEMENT

The decals shown at right have been placed on the weight bench in the indicated locations. If a decal is missing or illegible, call our toll-free HELPLINE at 1-800-736-6879, Monday through Saturday, 7 a.m. until 7 p.m. Central Time, to order a free replacement decal. Apply the replacement decal in the location shown.

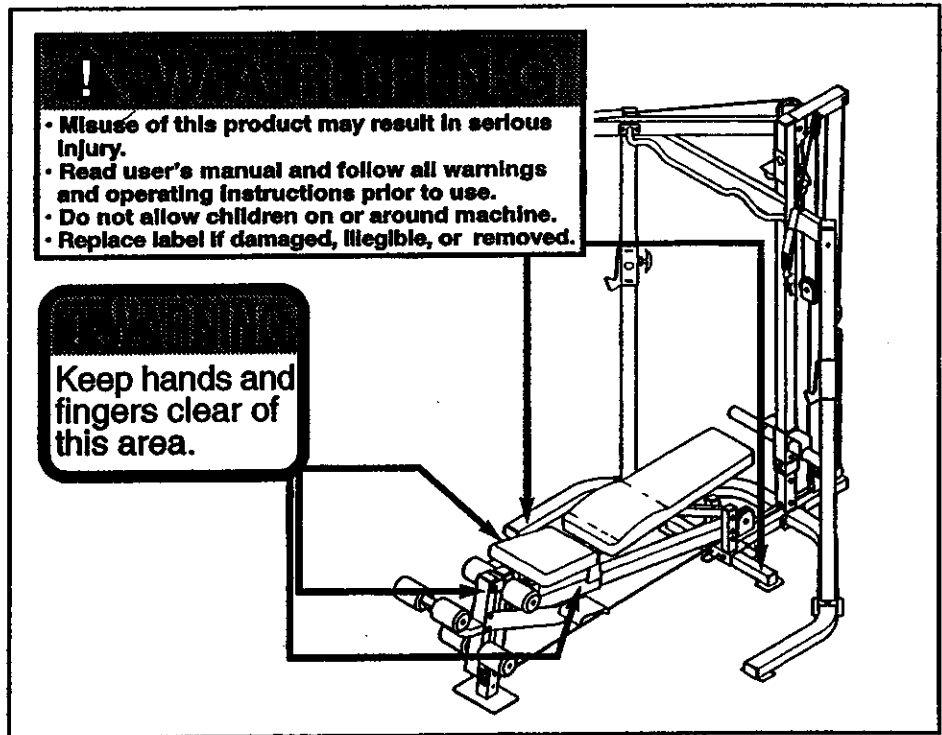

# IMPORTANT PRECAUTIONS

**⚠ WARNING:** To reduce the risk of serious injury, read the following important precautions before using the weight bench.

1. Read all instructions in this manual before using the weight bench. Use the weight bench only as described in this manual.
2. It is the responsibility of the owner to ensure that all users of the weight bench are adequately informed of all precautions.
3. The weight bench is intended for home use only. Do not use the weight bench in any commercial, rental, or institutional setting.
4. Use the weight bench only on a level surface. Cover the floor beneath the weight bench to protect the floor.
5. Make sure all parts are properly tightened each time you use the weight bench. Replace any worn parts immediately.
6. Keep children under 12 and pets away from the weight bench at all times.
7. Keep hands and feet away from moving parts.
8. Always wear athletic shoes for foot protection while exercising.
9. Make sure that the cables remain on the pulleys at all times. If the cables bind as you are exercising, stop immediately and make sure that the cables are on the pulleys.
10. Always set both weight rests at the same height.
11. The weight bench is designed to support a maximum user weight of 250 pounds. Do not place more than 30 pounds, including the barbell, on the weight rests. Do not place more than 150 pounds on the weight carriage. Note: The weight bench is designed to be used with an Olympic barbell. The weight bench does not include a barbell or weights.
12. Always place an equal amount of weight on each side of the weight carriage or barbell.
13. Always secure the weights with the weight clips when they are mounted on the weight carriage.
14. Always exercise with a partner. Your partner should be ready to catch the barbell if you cannot complete a repetition.
15. Always set the back leg over the center base before using the leg lever. Always attach the bench cable to the low cable before performing a bench exercise.
16. Always move the bench out of the way when performing squat exercises. Always disconnect the barbell from the high cable when performing an exercise that does not require it. The barbell could be lifted off of the weight rests and fall.
17. If you feel pain or dizziness at any time while exercising, stop immediately and lean your legs down.

**⚠ WARNING:** Before beginning this or any exercise program, consult your physician. This is especially important for persons over the age of 55, persons with pre-existing health problems, and persons who are pregnant. Read all instructions before using. SEARS assumes no responsibility for personal injury or property damage sustained by or through the use of this product.

# BEFORE YOU BEGIN

Thank you for selecting the WEIDER® PRO 575 weight bench. The PRO 575 is designed to be used with your own weight set (not included) to develop every major muscle group of the body. Whether your goal is a shapely figure, dramatic muscle size and strength, or a healthier cardiovascular system, the PRO 575 will help you to achieve the specific results you want.

**For your benefit, read this manual carefully before using the WEIDER® PRO 575 weight bench. If you have additional questions, please call our toll-free**

**HELPLINE at 1-800-736-6879, Monday through Saturday, 7 a.m. until 7 p.m. Central Time (excluding holidays). To help us assist you, please note the product model number and serial number before calling. The model number is 831.153230. The serial number can be found on a decal attached to the weight bench (see the front cover of this manual).**

Before reading further, please look at the drawing below and familiarize yourself with the parts that are labeled.

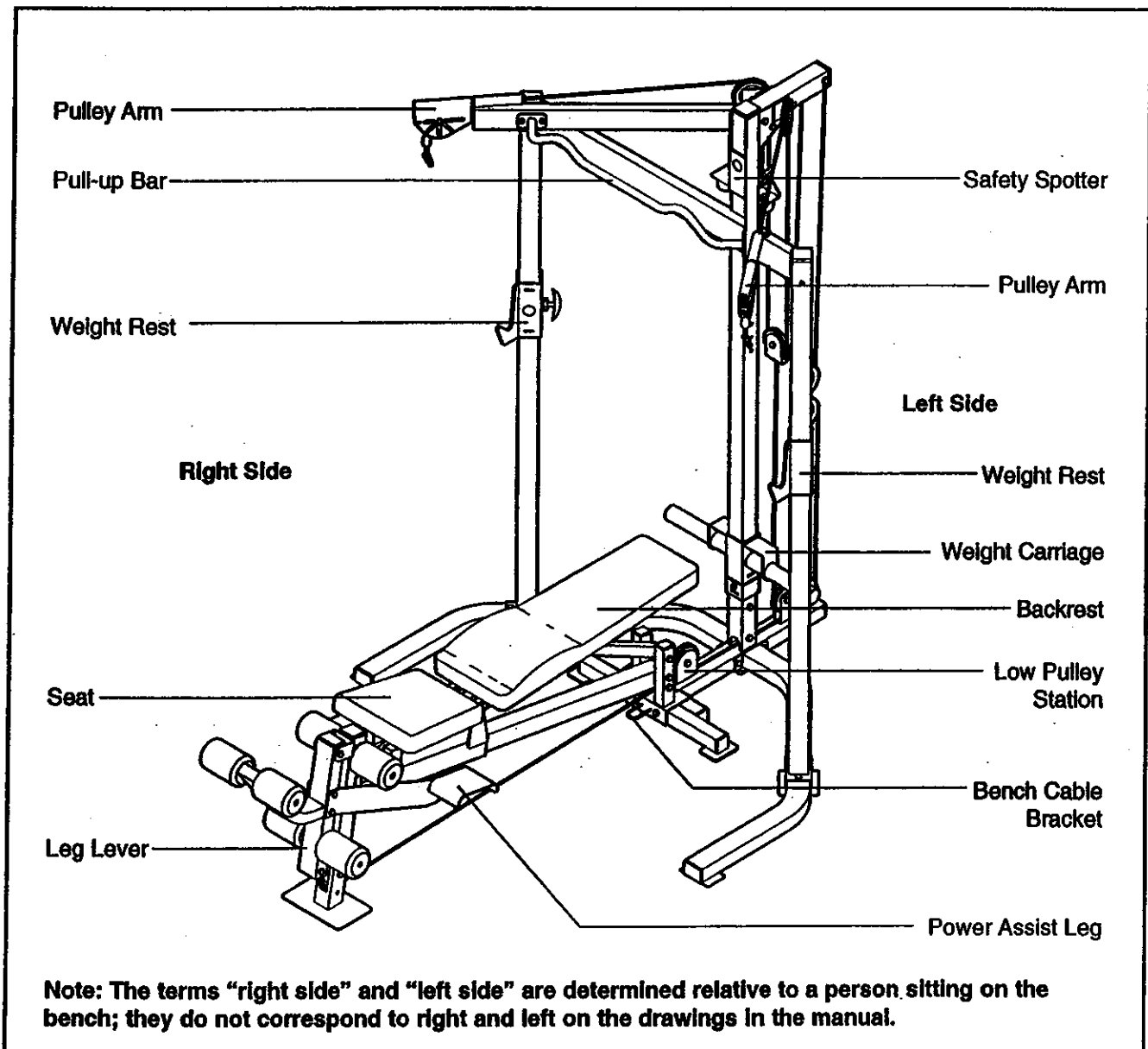

# PART IDENTIFICATION CHART

Refer to the drawings below to identify small parts used in assembly. The number in parentheses by each drawing is the key number of the part, from the PART LIST in the center of this manual. **Note: Some small parts may have been pre-attached. If a part is not in the parts bag, check to see if it has been pre-attached.**

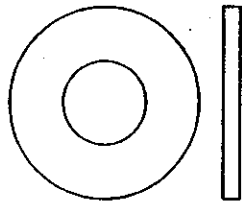

M10 Washer (79)

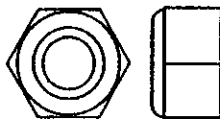

M10 Nylon Locknut (77)

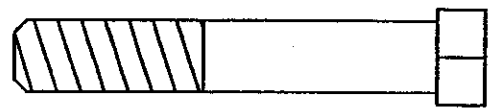

M10 x 57mm Bolt (78)

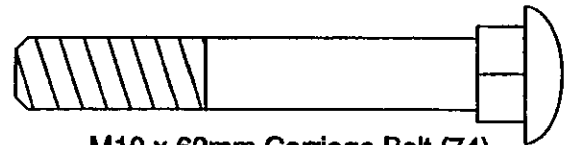

M10 x 62mm Carriage Bolt (74)



M6 Locknut (80)



M6 Washer (62)

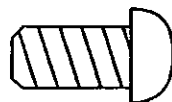

M8 x 12mm Screw (43)

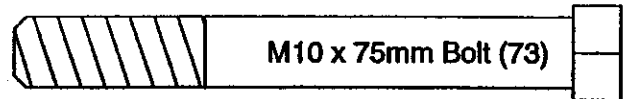

M10 x 75mm Bolt (73)

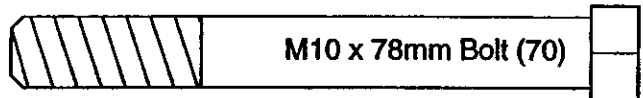

M10 x 78mm Bolt (70)



M5 Washer (92)

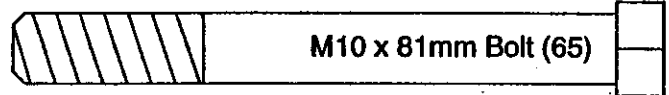

M10 x 81mm Bolt (65)



M10 x 45mm Bolt (76)

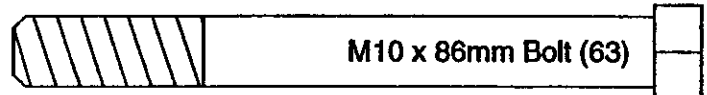

M10 x 86mm Bolt (63)

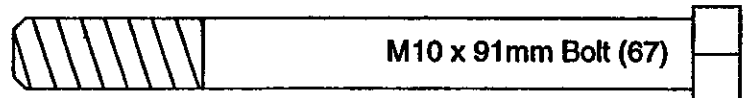

M10 x 91mm Bolt (67)

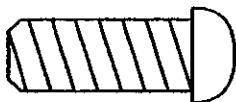

M10 x 25mm Button Bolt (81)

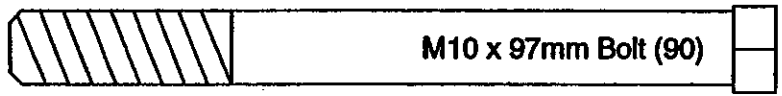

M10 x 97mm Bolt (90)

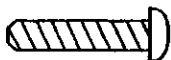

M4 x 19mm Screw (68)

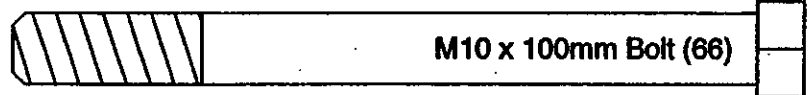

M10 x 100mm Bolt (66)

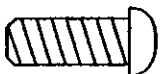

M6 x 16mm Bolt (72)



M10 x 102mm Bolt (91)

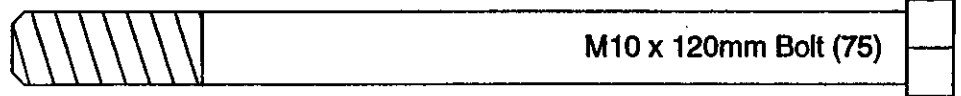

M10 x 120mm Bolt (75)

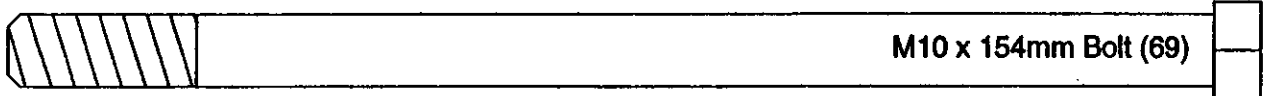

M10 x 154mm Bolt (69)

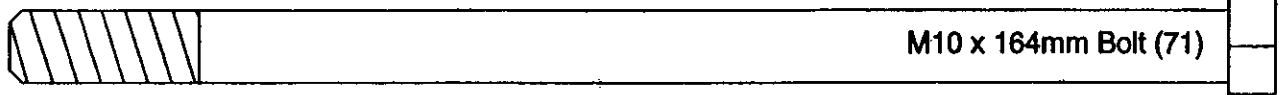

M10 x 164mm Bolt (71)

# ASSEMBLY

## Make Things Easier for Yourself



Everything in this manual is designed to ensure that the weight bench can be assembled successfully by anyone. However, it is important to realize that the versatile weight bench has many parts and that the assembly process will take time. Most people find that by simply asking plenty of time, assembly will go smoothly.

**Before beginning assembly, carefully read the following information and instructions:**

- Assembly requires two people.
- Place all parts in a cleared area and remove the packing materials. Do not dispose of the packing materials until assembly is completed.
- Tighten all parts as you assemble them, unless instructed to do otherwise.

- As you assemble the weight bench, make sure all parts are oriented as shown in the drawings.
- For help identifying small parts, use the PART IDENTIFICATION CHART on page 5.

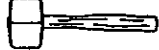
**The following tools (not included) are required for assembly:**

- Two adjustable wrenches 
- One rubber mallet 
- One standard screwdriver 
- One Phillips screwdriver 
- Lubricant, such as grease or petroleum jelly, and soapy water.

Assembly will be more convenient if you have a socket set, a set of open-end or closed-end wrenches, or a set of ratchet wrenches.

1. Before beginning assembly, make sure you understand the information in the box above. Important! Some of the parts described in the assembly steps may be pre-assembled.

Press a 2" x 3" Square Inner Cap (50) into the end of the Right Base (22).

Identify the Right Upright (2) by the positions of the numbers and holes. Attach the Right Upright to the Right Base (22) with two M10 x 62mm Carriage Bolts (74) and two M10 Nylon Locknuts (77). **Note: Be sure that the numbers on the Right Upright are on the side shown. Do not tighten the Nylon Locknuts yet.**

Repeat this step with the Left Base (23) and Left Upright (1). **Note: Be sure the numbers on the Left Upright are on the side shown in the inset drawing.**

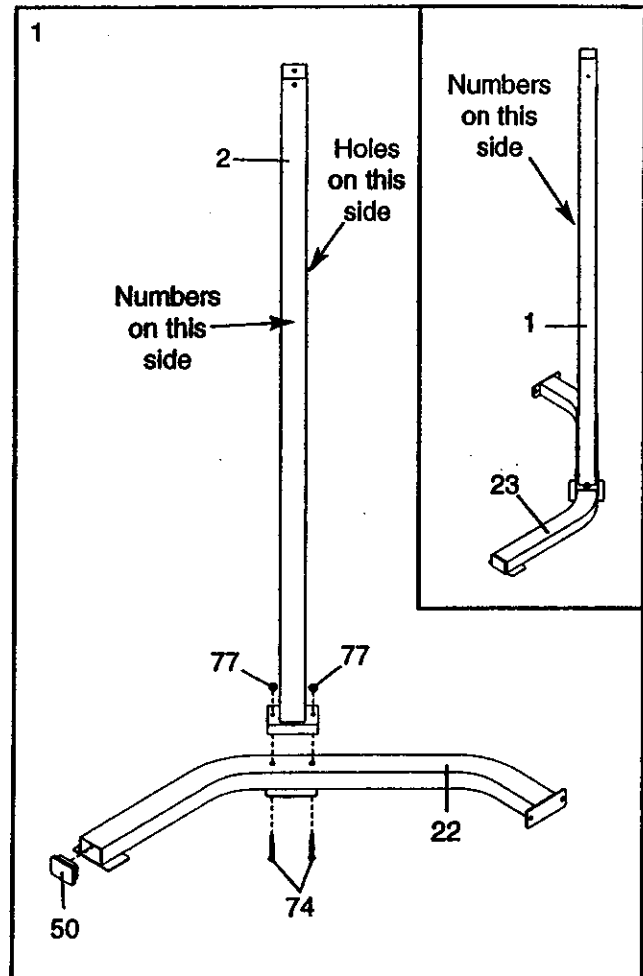

- Press two 50mm Thick Square Inner Caps (53) and a 2" x 3" Inner Cap (50) into the ends of the Center Base (24).

Have a second person hold the Right and Left Uprights (1, 2 [not shown]). Attach the Right and Left Bases (22, 23) to the Center Base (24) with two M10 x 97mm Bolts (90) and two M10 Nylon Locknuts (77). **Do not tighten the Nylon Locknuts yet.**

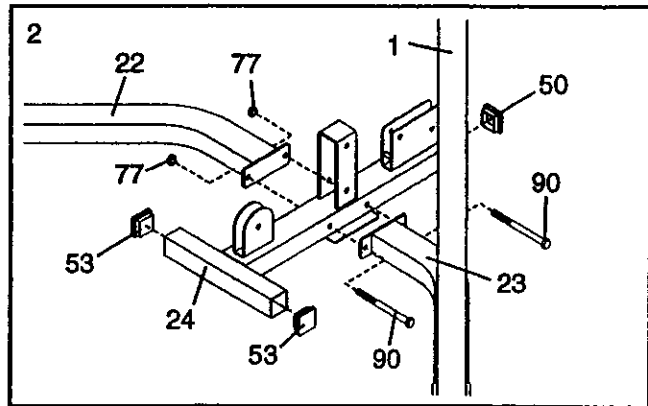

- Press two 2" Round Inner Caps (47) into the ends of the weight tube on the Weight Carriage (25). Press two 75mm Bushings (26) into the top and bottom of the Weight Carriage.

Orient the Weight Carriage (25) and Center Upright (3) so that the welded bolt and letters are on the indicated sides. Slide the Weight Carriage onto the bottom of the Center Upright.

Attach the Carriage Stop (27) to the indicated hole in the Center Upright (3) with an M10 x 86mm Bolt (63) and an M10 Nylon Locknut (77).

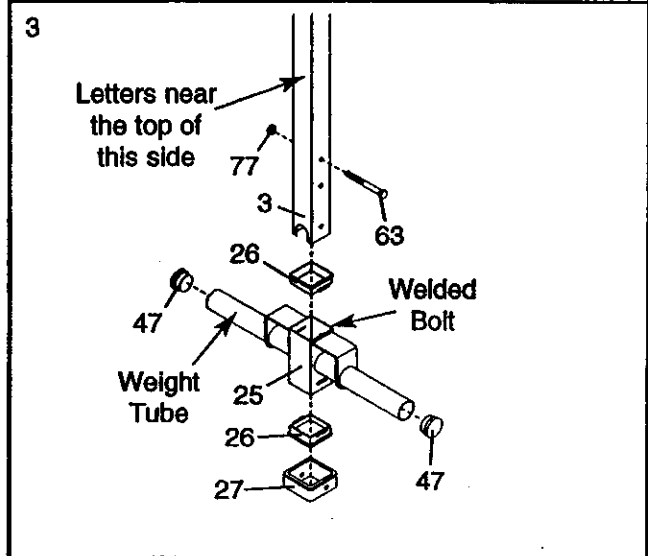

- Attach the Center Upright (3) to the Center Base (24) with two M10 x 75mm Bolts (73), four M10 Washers (79), and two M10 Nylon Locknuts (77). **Do not tighten the Nylon Locknuts yet.**

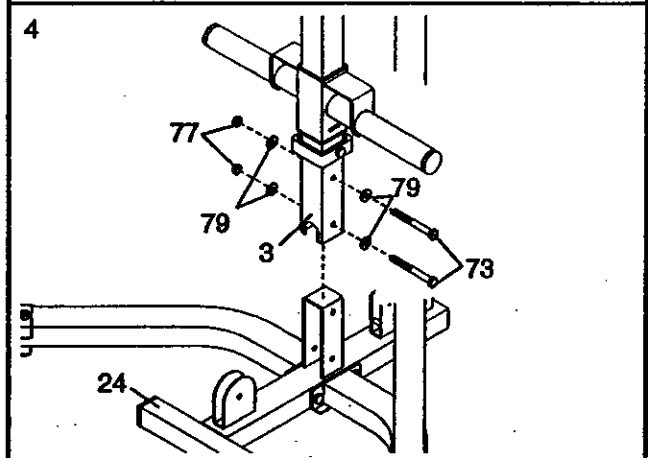

- Press two 75mm Bushings (26) into the top and bottom of the Safety Spotter (10).

Attach two Safety Spotter Bumpers (34) to the Safety Spotter (10) with two M10 x 25mm Button Bolts (81), two M10 Washers (79), and two M10 Nylon Locknuts (77).

Pull the Knob (30) out as far as it will go. Slide the Safety Spotter (10) onto the top of the Center Upright (3) and engage the Knob into an adjustment hole. Turn the Knob clockwise until tight.

Press a 60mm Square Inner Cap (46) into the top of the Center Upright (3).

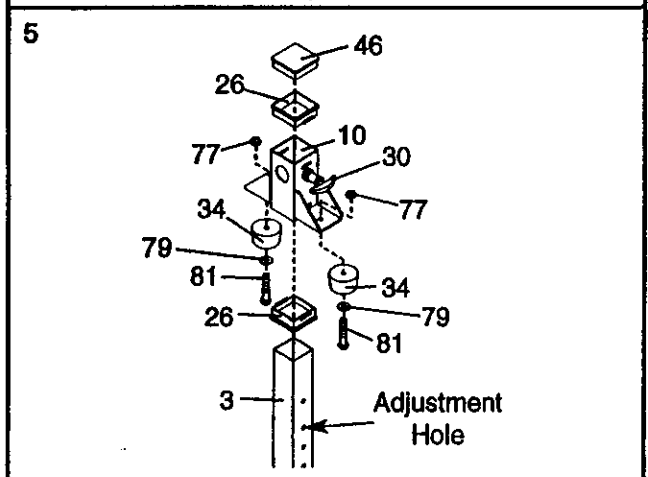

- Press two 75mm Bushings (26) into the top and bottom of the Right Weight Rest (12).

Pull the Knob (30) out as far as it will go. Slide the Right Weight Rest (12) onto the Right Upright (2) and snap the Knob into an adjustment hole in the Upright. Turn the Knob clockwise until tight.

Repeat this step with the Left Weight Rest (not shown).

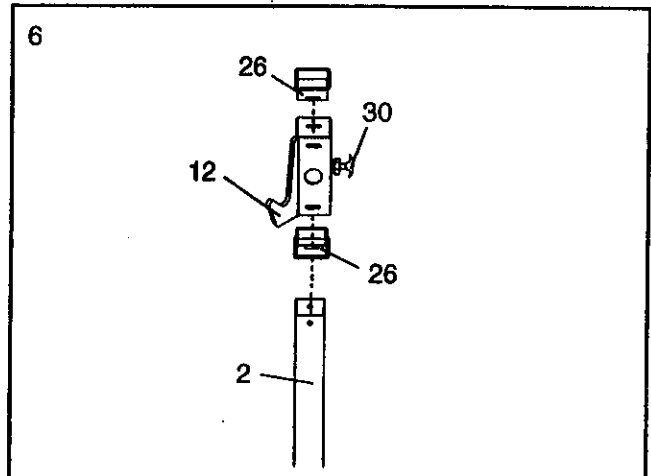

- Press two 60mm Square Inner Caps (46) into the top of the Left and Right Uprights (1, 2).

Orient the Center Frame (4) with the decal on the side shown. Attach the Center Frame to the Left and Right Uprights (1, 2) with four M10 x 78mm Bolts (70), four M10 Washers (79), and four M10 Nylon Locknuts (77). Do not tighten the Nylon Locknuts yet.

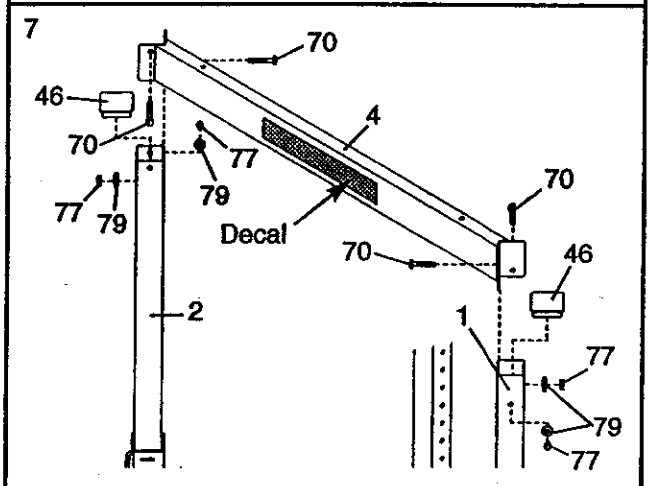

- Press two 38.1mm x 76.2mm Inner Caps (49) into the end of the Right and Left Frames (5, 6).

Attach the Right and Left Frames (5, 6) to the Center Upright (3) with an M10 x 81mm Bolt (65) and an M10 Nylon Locknut (77).

Attach the Right Frame (5) to the Center Frame (4) with an M10 x 120mm Bolt (75), an M10 Washer (79), and an M10 Nylon Locknut (77). Attach the Left Frame (6) to the Center Frame in the same manner.

**Do not tighten the M10 Nylon Locknuts (77) yet.**

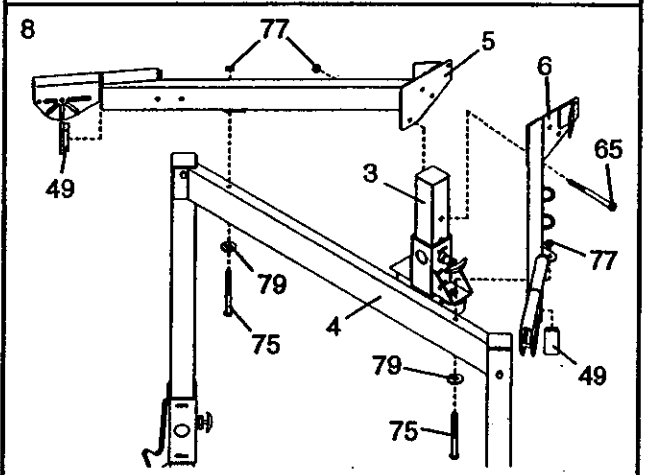

- Press a 60mm Square Arched Inner Cap (89) into the end of the Top Frame (9).

Attach the Top Frame (9) to the Right and Left Frames (5, 6) with two M10 x 81mm Bolts (65) and two M10 Nylon Locknuts (77). Do not tighten the Nylon Locknuts yet.

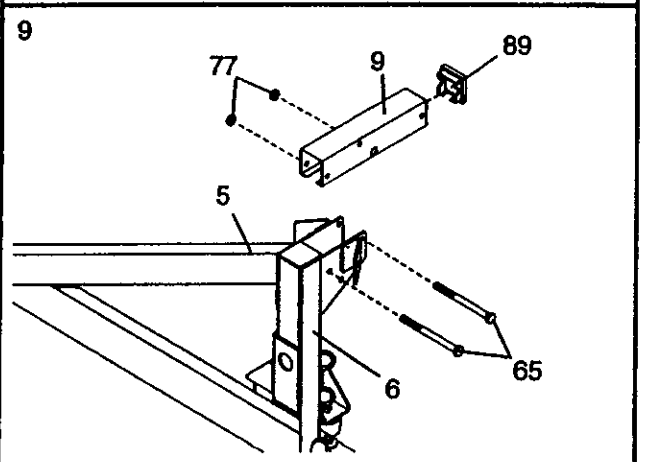



10. Orient the Pull-up Bar (8) with the bend on top. Attach the Pull-up Bar to the Right Frame (5) with two M10 x 57mm Bolts (78), two M10 Washers (79), and two M10 Nylon Locknuts (77). **Do not tighten the Nylon Locknuts yet.**

Attach the Pull-up Bar (8) to the Left Frame (not shown) in the same manner.

**Tighten the M10 Nylon Locknuts (77) used in steps 1-10.**

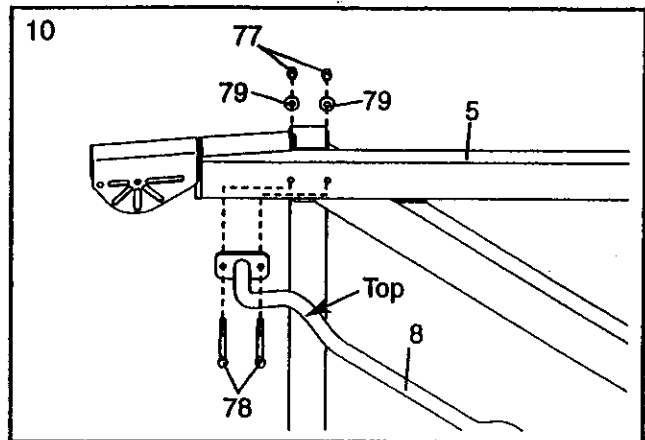

11. Press two 38mm x 50mm Inner Caps (52) into the top of the Back Leg (39). Press two 50mm Square Inner Caps (51) into the ends of the Stabilizer (40).

Orient the Stabilizer (40) so the decal is in the position shown. Attach the Back Leg (39) to the Stabilizer with two M10 x 62mm Carriage Bolts (74) and two M10 Nylon Locknuts (77). **Do not tighten the Nylon Locknuts yet.**

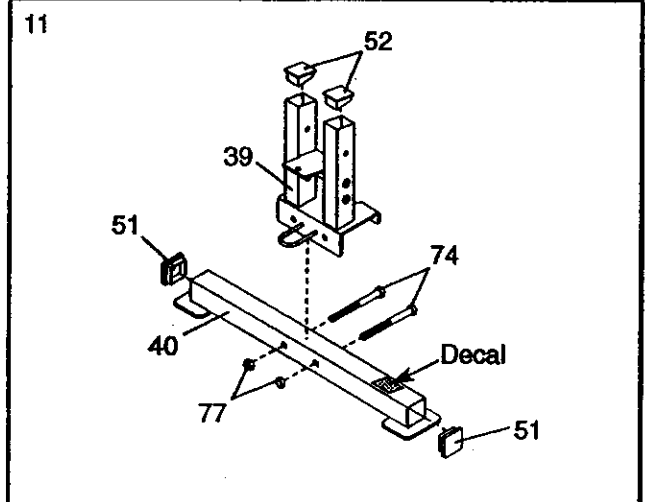

12. Press a 60mm Square Inner Cap (46) into the top of the Front Leg (18).

Orient the Bench Frame (14) as shown. Attach the Bench Frame to the Front Leg (18) with two M10 x 78mm Bolts (70), two M10 Washers (79), and two M10 Nylon Locknuts (77). **Do not tighten the Nylon Locknuts yet.**

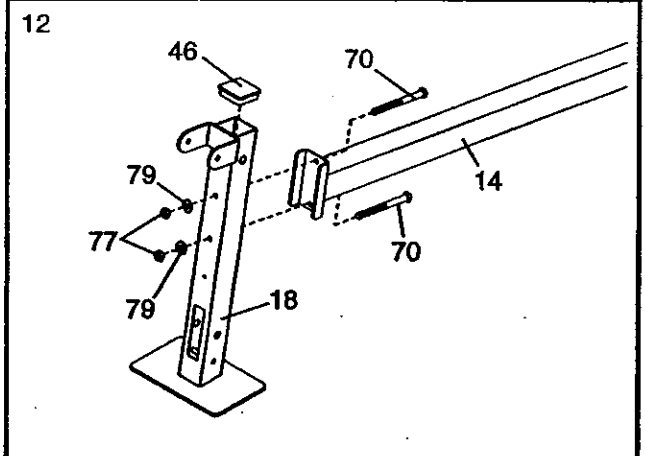

13. Press a 38mm x 50mm Inner Cap (64) into the indicated part of the Sliding Seat Frame (15). Press two 75mm Bushings (26) into the ends of the Sliding Seat Frame.

Orient the Sliding Seat Frame (15) as shown. Pull the Knob (not shown) out as far as it will go. Slide the Sliding Seat Frame onto the Bench Frame (14) and engage the Knob into an adjustment hole in the Bench Frame.

Press a 60mm Square Angled Inner Cap (95) into the end of the Bench Frame (14).

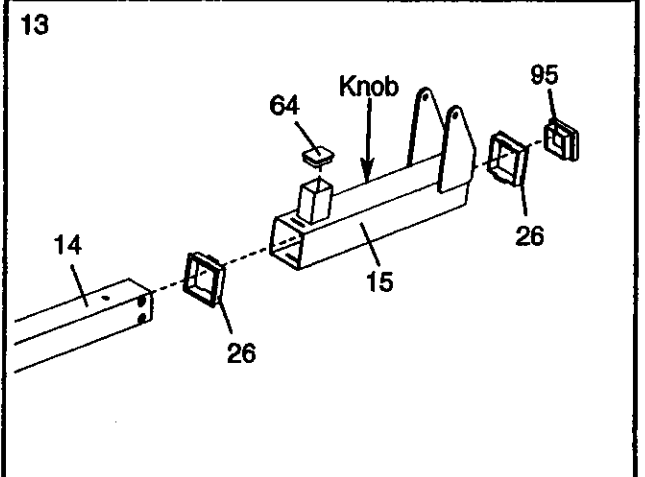

14. Attach the Bench Frame (14) to the Back Leg (39) with an M10 x 78mm Bolt (70), two M10 x 164mm Bolts (71), an M10 Washer (79), and three M10 Nylon Locknuts (77). Do not tighten the Nylon Locknuts yet.

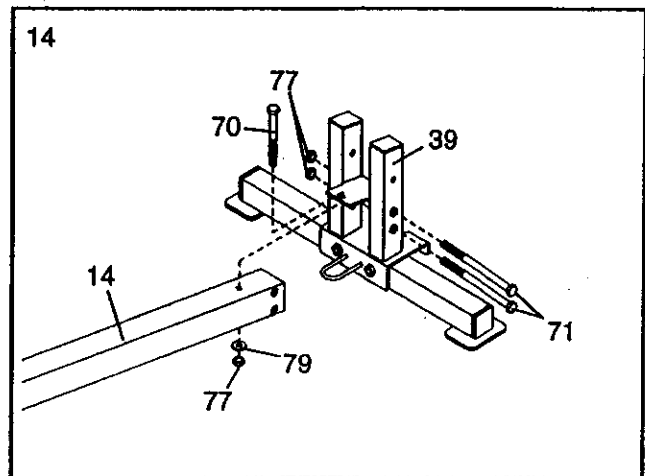

15. Attach the Leg Lever Bumper (54) to the Front Leg (18) with the M4 x 19mm Screw (68) and an M5 Washer (92).

Press a 38.1mm x 76.2mm Inner Cap (49) and a 2" x 3" Inner Cap (50) into the Leg Lever (19).

Lubricate an M10 x 102mm Bolt (91). Attach the Leg Lever (19) to the Front Leg (18) with the Bolt and an M10 Nylon Locknut (77). Do not over-tighten the Nylon Locknut; the Leg Lever must be able to pivot easily.

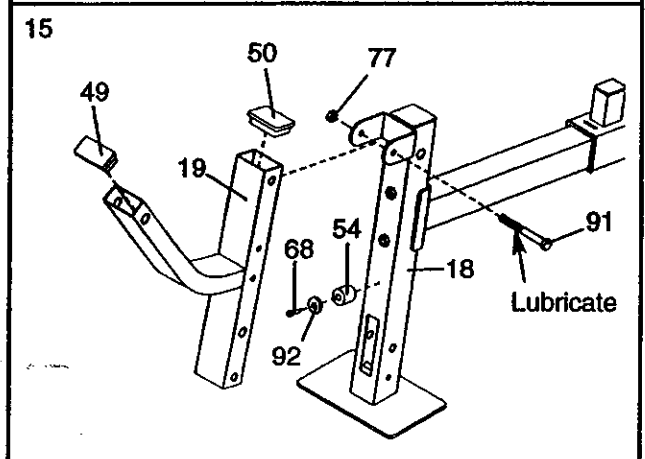

16. Press four 25.4mm x 38.1mm Inner Caps (45) into the Backrest Frame (16).

Orient the Backrest (38) as shown. Attach the Backrest to the Backrest Frame (16) with four M6 x 16mm Bolts (72).

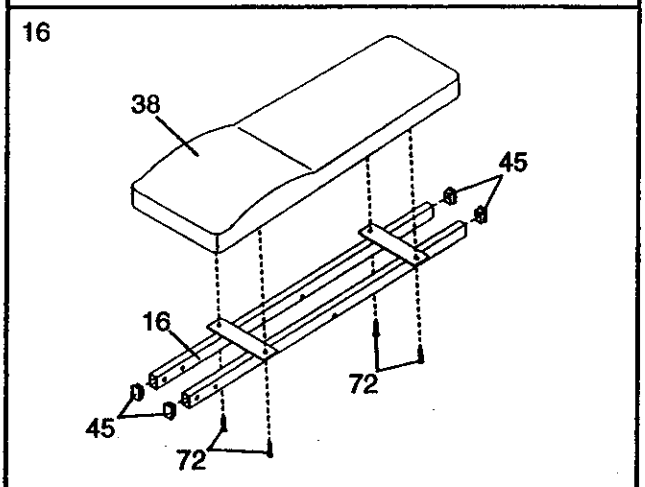

17. Press two 38mm Square Inner Caps (44) into the ends of the Support Leg (13).

Lubricate an M10 x 154mm Bolt (69). Attach the Support Leg (13) to the Backrest Frame (16) with the Bolt, two M10 Washers (79), and an M10 Nylon Locknut (77).

Lubricate an M10 x 164mm Bolt (71). Attach the Support Leg (13) to the Back Leg (39) with the Bolt, two M10 Washers (79), and an M10 Nylon Locknut (77).

Lubricate two M10 x 45mm Bolts (76). Attach the Backrest Frame (16) to the Sliding Seat Frame (15) with the Bolts, two M10 Washers (79), and two M10 Nylon Locknuts (77).

Do not overtighten the M10 Nylon Locknuts (77); the Support Leg (13) and the Backrest Frame (16) must be able to pivot easily.

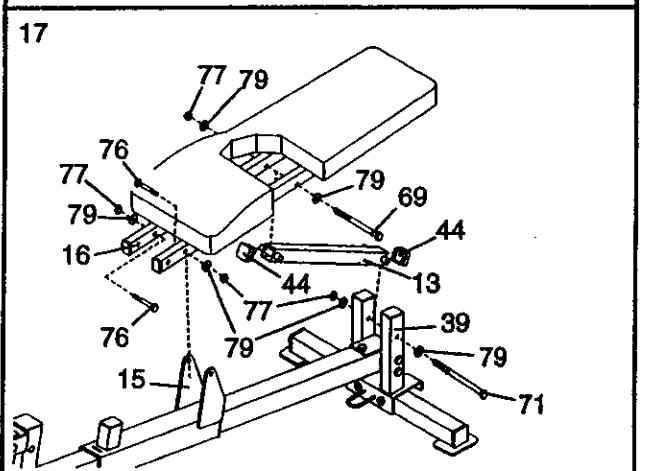

18. Press two 38mm Square Inner Caps (44) into the ends of the Seat Frame (17).

Orient the Seat (37) with the wide end on the side shown. Attach the Seat (37) to the Seat Frame (17) with four M6 x 16mm Bolts (72).

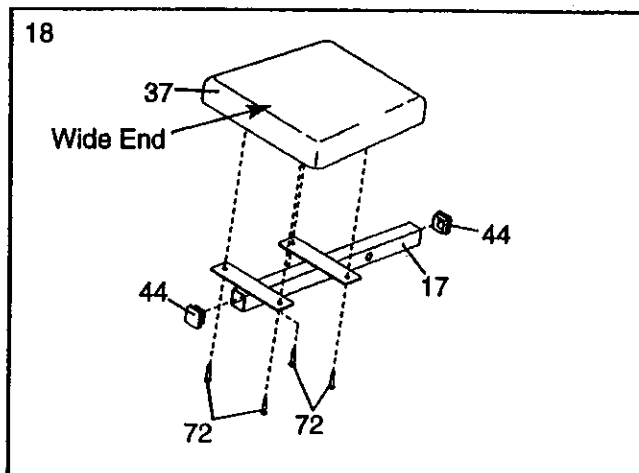

19. Lubricate an M10 x 154mm Bolt (69). Attach the Seat Frame (17) to the Backrest Frame (16) with the Bolt, two M10 Washers (79), and an M10 Nylon Locknut (77). Do not overtighten the Nylon Locknut; the Seat Frame must be able to pivot easily.

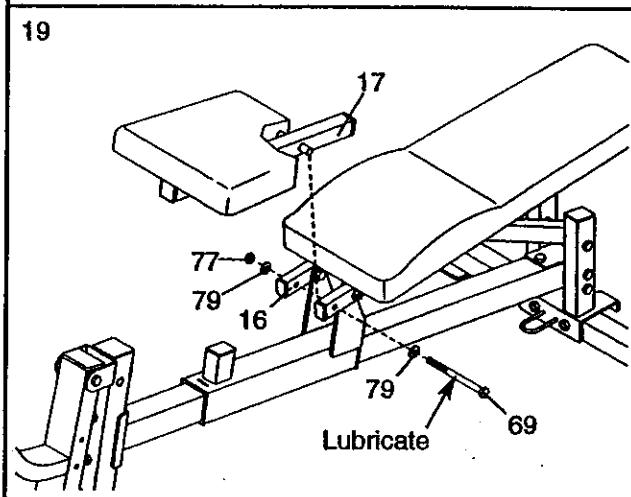

20. Attach the Right and Left Power Assist Legs (20, 21) to the Leg Lever (19) with two M10 x 100mm Bolts (66) and two M10 Nylon Locknuts (77).

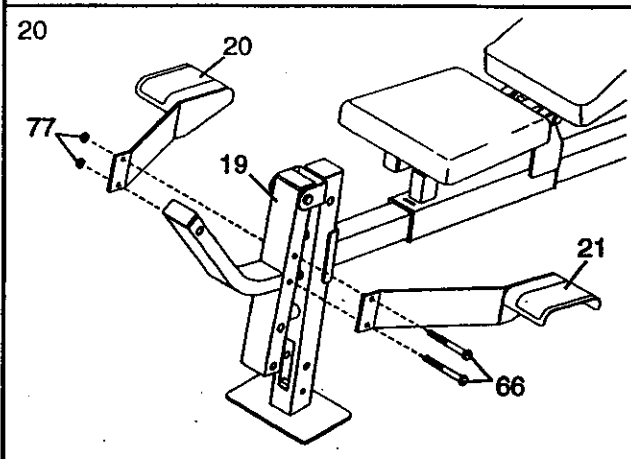

21. Refer to the CABLE DIAGRAMS on page 16 of this manual to identify the different cables included with the weight bench.

Locate the Bench Cable (58). Route the Cable through the Front Leg (18) and attach it to the Leg Lever (19) with an M10 x 91mm Bolt (67), two 35mm Spacers (82), two M10 Washers (79), and an M10 Nylon Locknut (77).

Press a 2" x 3" Inner Cap (50) into the bottom of the Leg Lever (19).

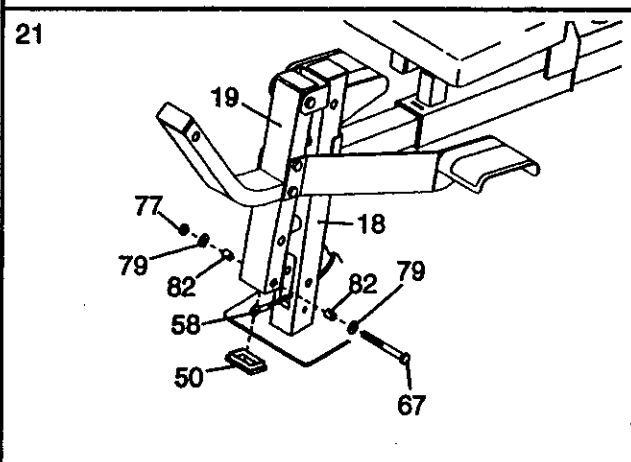

22. Route the Bench Cable (58) under a 4 1/2" Pulley (35). Attach the Pulley to the Front Leg (18) with an M10 x 75mm Bolt (73), two 17mm Spacers (96), two M10 Washers (79), and an M10 Nylon Locknut (77).

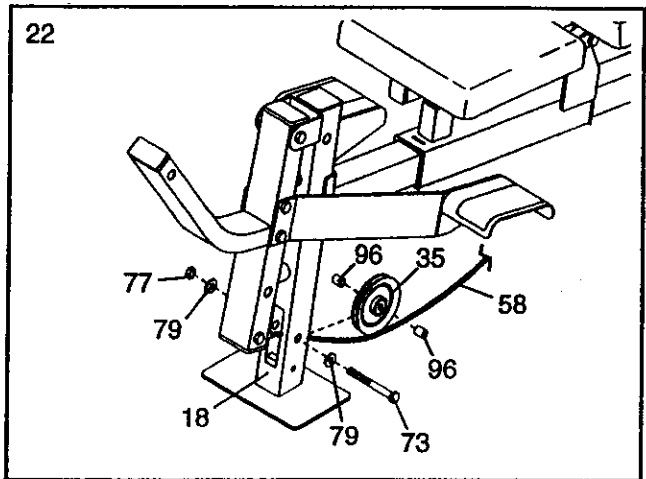

23. Attach the Bench Cable (58) to the Back Leg (39) with a Cable Clip (28).

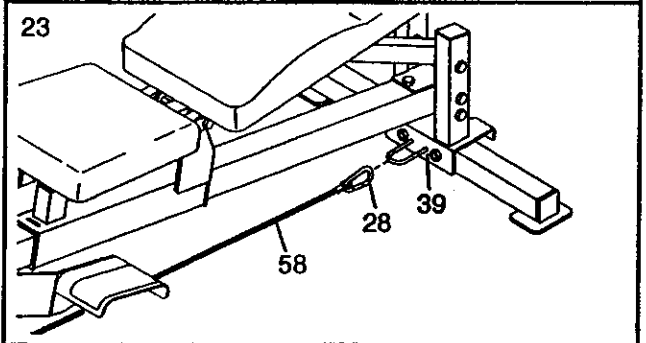

24. Press a 19mm Round Inner Cap (48) into each end of the three Pad Tubes (41).

Slide two Pad Tubes (41) through the holes in the Leg Lever (19). Slide the third Pad Tube through the holes in the Front Leg (18). Slide two Foam Pads (42) onto each Pad Tube.

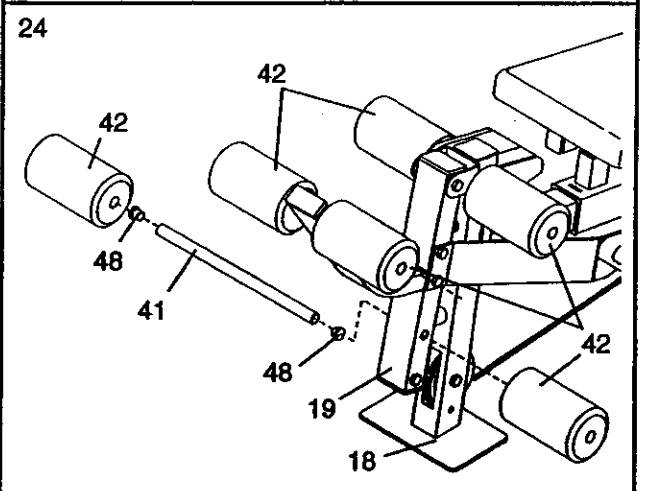

25. Locate the High Cable (61).

See the inset drawing. Slide a Cable Ball (56) onto the end of the High Cable (61). Thread an M6 Locknut (80) onto the Cable as far as it will go. Tighten a Cable Eye (57) onto the Cable. Hold the Cable Eye and fully tighten the Locknut against the Cable Eye. Slide the Cable Ball over the Locknut and the Cable Eye.

Route the end of the High Cable (61) without a Cable Ball (56) through the tube on the left Pulley Arm (7). Wrap the Cable around a 4 1/2" Pulley (35) and attach the Pulley to the Pulley Arm with an M10 x 45mm Bolt (76) and an M10 Nylon Locknut (77). Note: Be sure the Cable is under the indicated pin on the Pulley Arm.

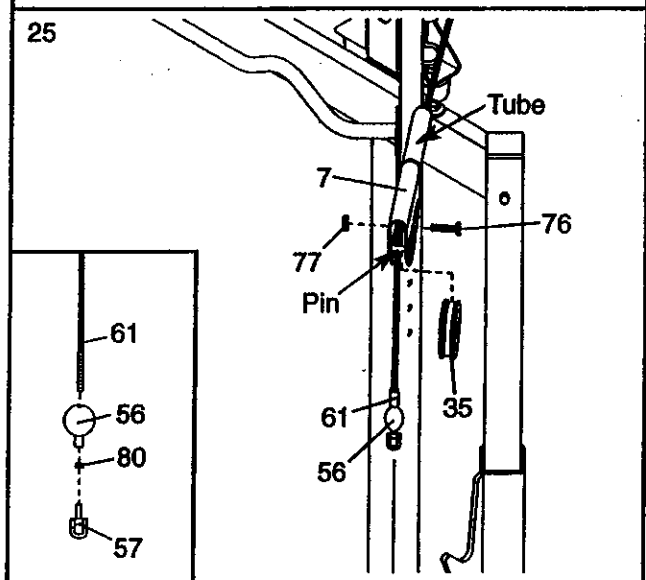

26. Wrap the High Cable (61) around an 88mm Pulley (36). Attach the Pulley and a Small Cable Trap (93) to the Left Frame (6) with an M10 x 45mm Bolt (76) and an M10 Nylon Locknut (77).

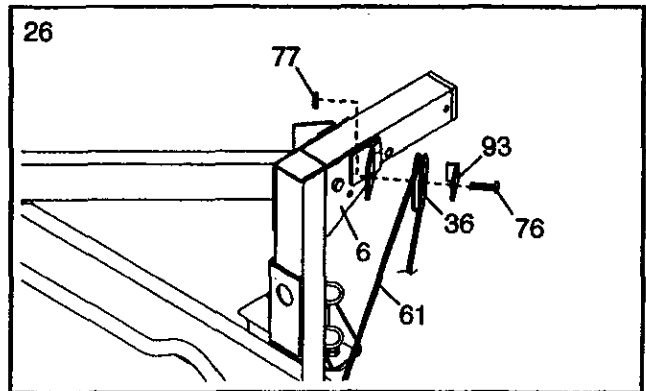

27. Wrap the High Cable (61) around a 4 1/2" Pulley (35). Attach the Pulley and a Large Cable Trap (55) to the "U"-Bracket (33) with an M10 x 45mm Bolt (76) and an M10 Nylon Locknut (77).

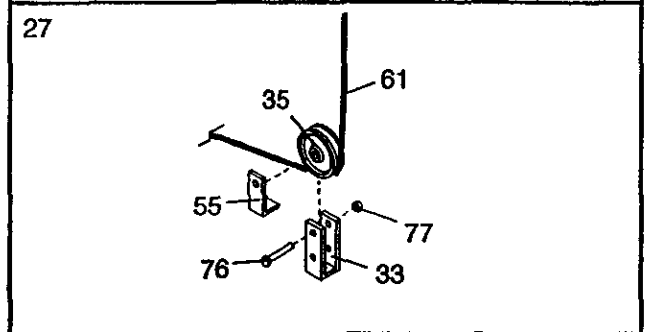

28. Wrap the High Cable (61) around an 88mm Pulley (36). Attach the Pulley and a Small Cable Trap (93) to the Right Frame (5) with an M10 x 45mm Bolt (76) and an M10 Nylon Locknut (77).

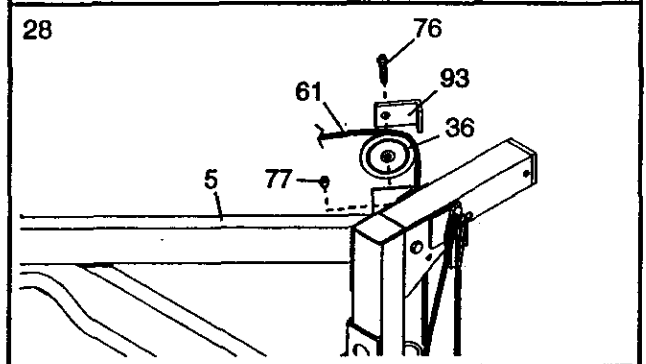

29. Route the High Cable (61) through the tube on the right Pulley Arm (7). Wrap the Cable around a 4 1/2" Pulley (35). Attach the Pulley to the Pulley Arm with an M10 x 45mm Bolt (76) and an M10 Nylon Locknut (77).

See the inset drawing. Slide a Cable Ball (56) onto the end of the High Cable (61). Thread an M6 Locknut (80) onto the Cable as far as it will go. Tighten a Cable Eye (57) onto the Cable. Hold the Cable Eye and fully tighten the Locknut against the Cable Eye. Slide the Cable Ball over the Locknut and the Cable Eye.

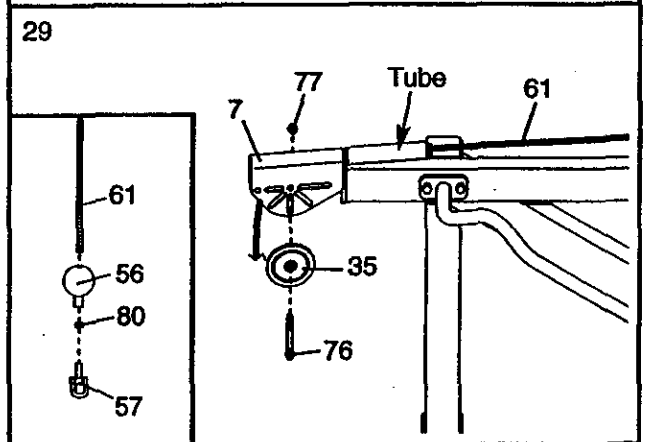

30. Locate the Carriage Cable (60). Attach the end of the Cable inside the Top Frame (9) with an M10 x 75mm Bolt (73), two 27mm Spacers (94), two M10 Washers (79), and an M10 Nylon Locknut (77).

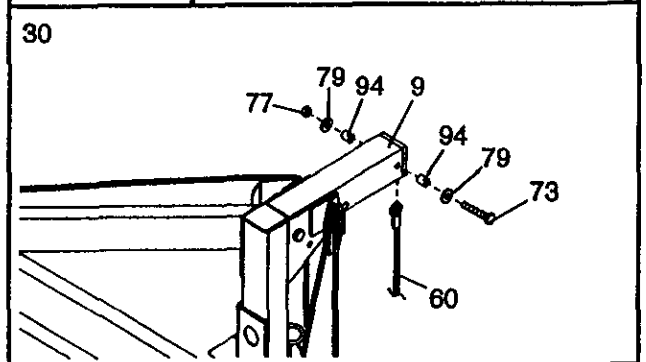

31. Wrap the Carriage Cable (60) around a 4 1/2" Pulley (35). Attach the Pulley and a Large Cable Trap (55) to the single set of holes in the pair of Pulley Plates (31) with an M10 x 45mm Bolt (76) and an M10 Nylon Locknut (77).

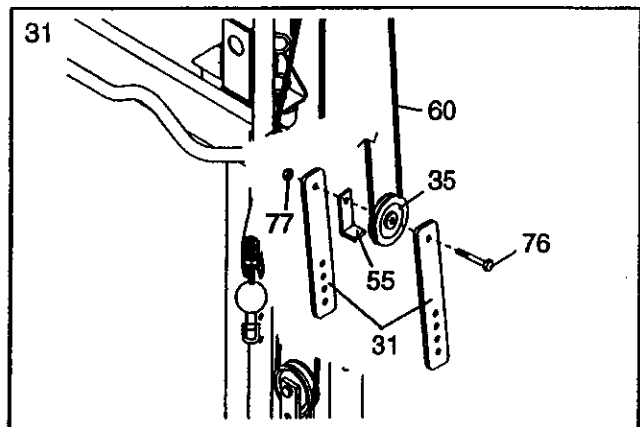

32. Wrap the Carriage Cable (60) around an 88mm Pulley (36). Attach the Pulley inside the Top Frame (9) with an M10 x 75mm Bolt (73), two 17mm Spacers (96), two M10 Washers (79), and an M10 Nylon Locknut (77).

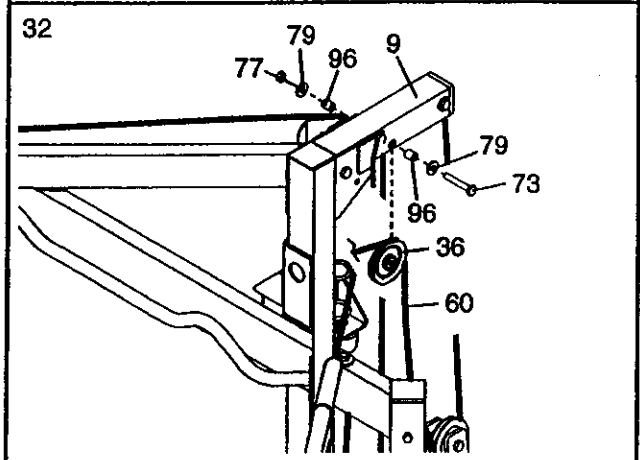

33. Wrap the Carriage Cable (60) around an 88mm Pulley (36). Attach the Pulley between the Right and Left Frames (5, 6) with an M10 x 81mm Bolt (65), two 15mm Spacers (83), and an M10 Nylon Locknut (77).

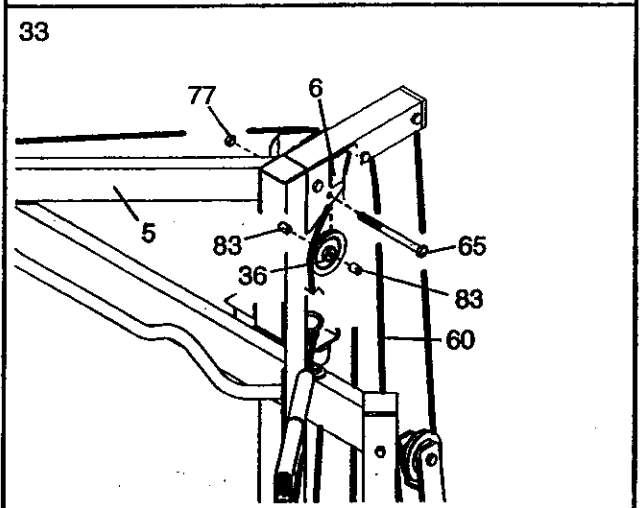

34. Attach the end of the Carriage Cable (60) to the welded bolt on the Weight Carriage (25) with an M10 Nylon Locknut (77).

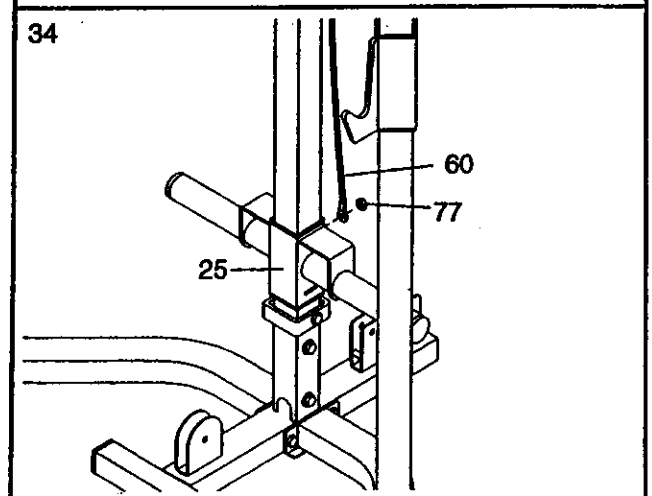

35. Locate the Low Cable (59). Lay the Cable inside the bracket on the Center Base (24) so that the ball is on the side shown. Attach a 4 1/2" Pulley (35) inside the bracket with an M10 x 45mm Bolt (76) and an M10 Nylon Locknut (77).

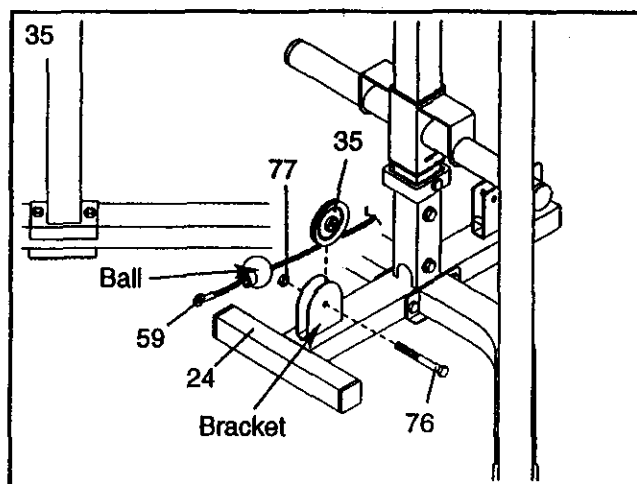

36. Route the Low Cable (59) through the Center Upright (3) and under the bar in the bracket on the Center Base (24). Wrap the Cable around an 88mm Pulley (36). Attach the Pulley to the rear hole in the bracket on the Center Base with an M10 x 45mm Bolt (76) and an M10 Nylon Locknut (77).

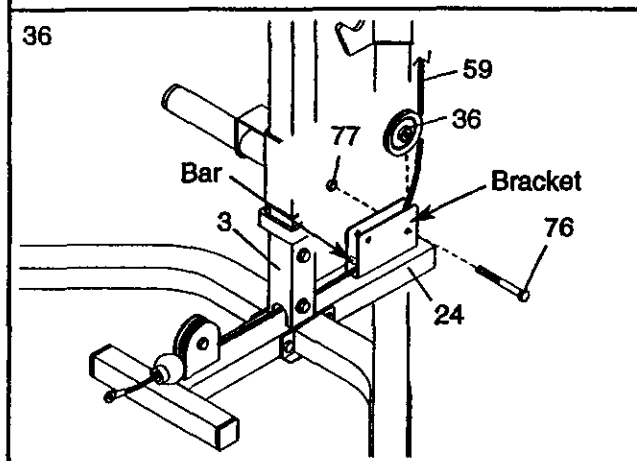

37. Wrap the Low Cable (59) around a 4 1/2" Pulley (35). Attach the Pulley and a Large Cable Trap (55) to the bottom set of holes in the pair of Pulley Plates (31) with an M10 x 45mm Bolt (76) and an M10 Nylon Locknut (77).

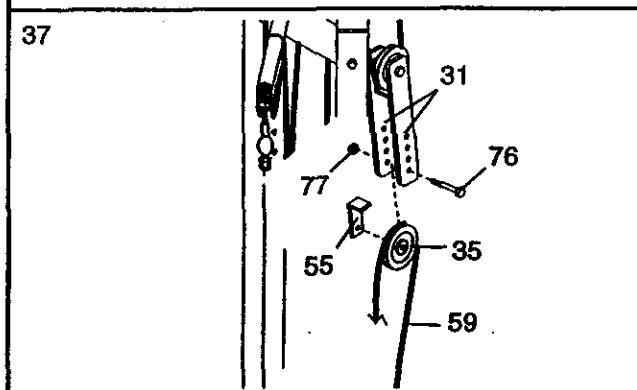

38. Wrap the Low Cable (59) around an 88mm Pulley (36). Attach the Pulley to the front hole in the bracket on the Center Base (24) with an M10 x 45mm Bolt (76) and an M10 Nylon Locknut (77).

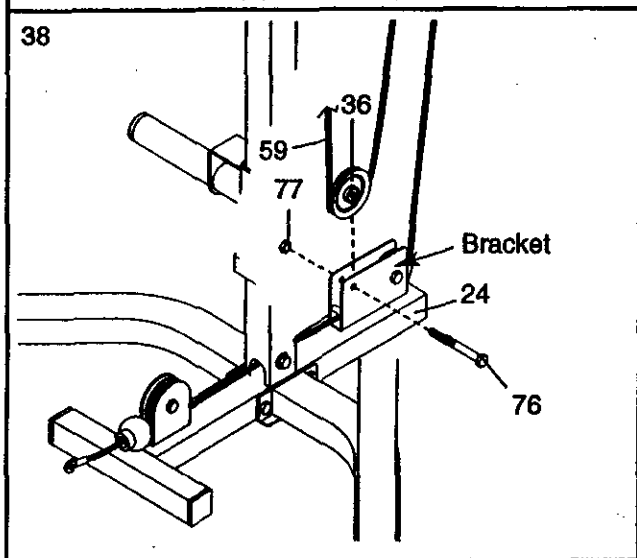

39. Attach the Low Cable (59) to the "U"-Bracket (33) with an M6 Washers (62) and an M6 Locknut (80). Do not completely tighten the Locknut; it should be threaded onto the end of the Cable until only two threads are showing above the Locknut, as shown in the inset drawing.

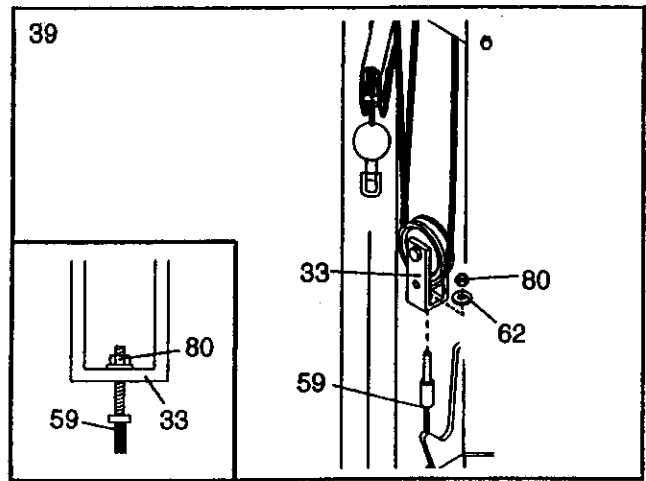

40. Make sure all parts of the weight bench are properly tightened. In addition, pull each cable a few times to make sure the cables move smoothly over the pulleys. If the cables do not move smoothly, locate and correct the problem. When weights are used, the cables may be damaged if they are incorrectly routed. Refer to the CABLE DIAGRAMS below for correct cable routing.

The use of all remaining parts will be explained in ADJUSTMENTS, beginning on the following page.

## CABLE DIAGRAMS

The cable diagrams below show the proper routing of the Bench Cable (58), the Low Cable (59), the Carriage Cable (60), and the High Cable (61). Use the diagram to make sure that the cables and the cable traps have been assembled correctly. If the cables have not been correctly routed, the weight bench will not function properly and damage may occur. The numbers show the correct route for each cable. Make sure that the cable traps do not touch or bind the cables.

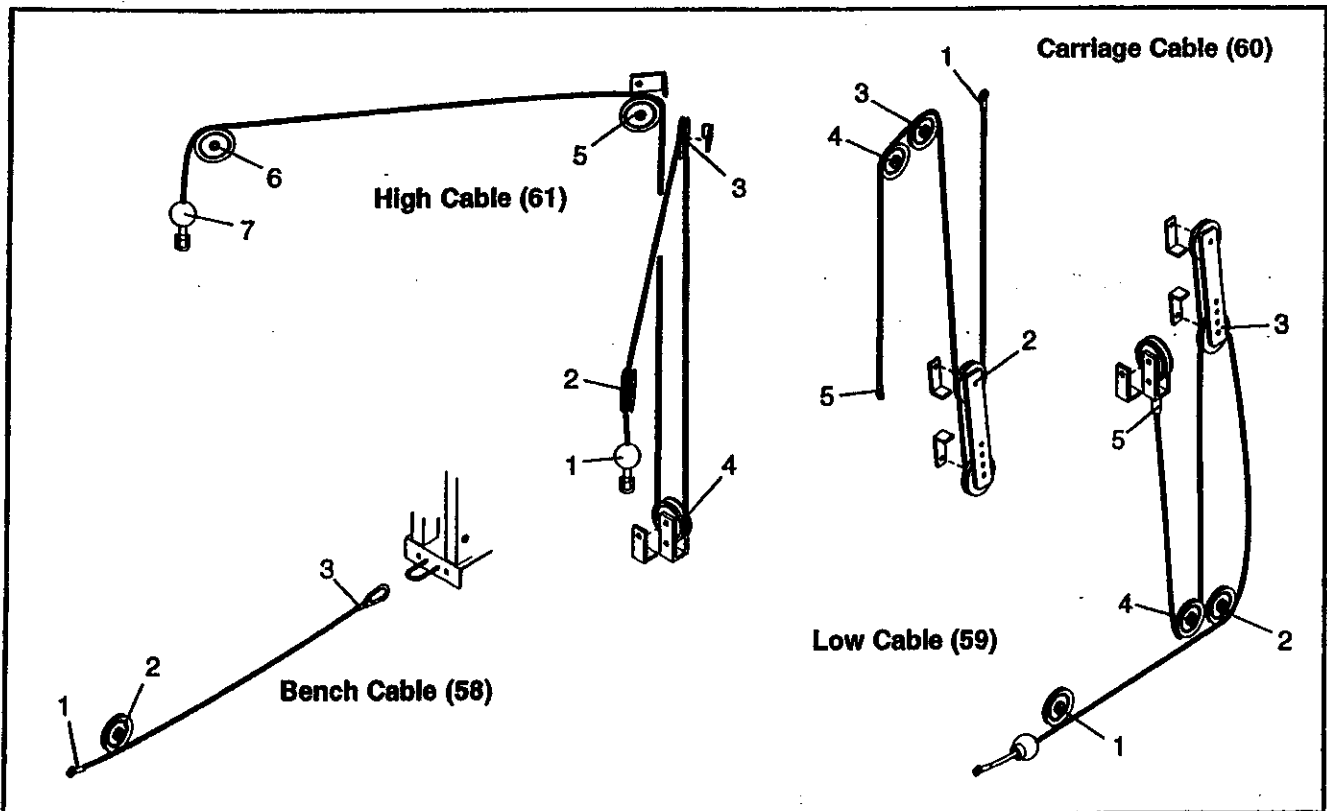



# ADJUSTMENTS

This section explains how to adjust the weight bench. The first time you perform an exercise that uses the safety spotter, adjust the bench to the position that is best for you. Note the position of the weight rest and safety spotter on the BENCH ADJUSTMENT CHART, on page 20 of this manual. When preparing to perform the exercise again, refer back to the chart for a quick reference to your personal settings.

See the EXERCISE GUIDELINES on page 21 for important information about how to get the most benefit from your exercise program. Also, refer to the accompanying exercise guide to see the correct form for each exercise.

Make sure all parts are properly tightened each time you use the weight bench. Replace any worn parts immediately. The weight bench can be cleaned with a damp cloth and a mild, non-abrasive detergent. Do not use solvents.

## ADJUSTING THE BACKREST

The Backrest (38) can be used in a decline position, a level position, or any of five incline positions. To adjust the Backrest, turn the Knob (30) counterclockwise until loose. Pull the Knob out as far as it will go and slide the Sliding Seat Frame (15) to the desired position. Engage the Knob into an adjustment hole in the Bench Frame (14). Turn the Knob clockwise until tight.

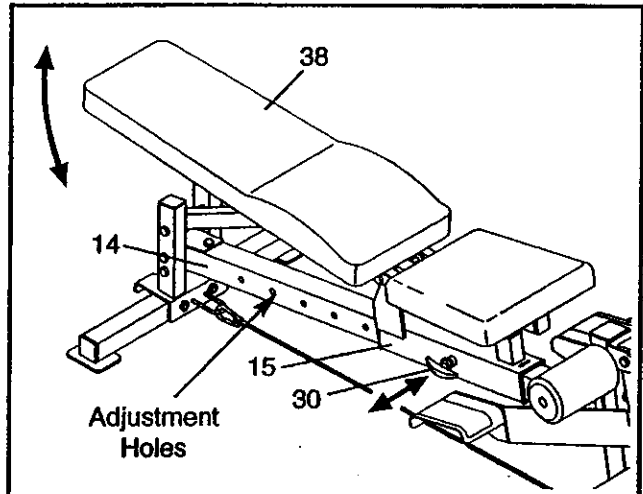

## ADJUSTING THE WEIGHT RESTS AND SAFETY SPOTTER

Before performing an exercise that uses a barbell, adjust the Weight Rests (11, 12) and Safety Spotter (25) to the height that is best suited for that exercise. The Weight Rests should be at a comfortable height for lifting and replacing the barbell. Moving the Safety Spotter (10) will change the distance that the barbell can move. First, attach the barbell to the high cable (see ATTACHING A BARBELL TO THE CABLES, on page 18). Then, set the Safety Spotter to the position that will stop the barbell at the lowest point that you want it to go during the exercise.

To adjust a Weight Rest (11, 12) turn the Knob (30) counterclockwise until loose. Pull the Knob out as far as it will go and move the Weight Rest to the desired height. Engage the Knob into an adjustment hole in the Upright (1, 2) and turn it clockwise until tight.

The Safety Spotter (10) can be adjusted in the same manner.

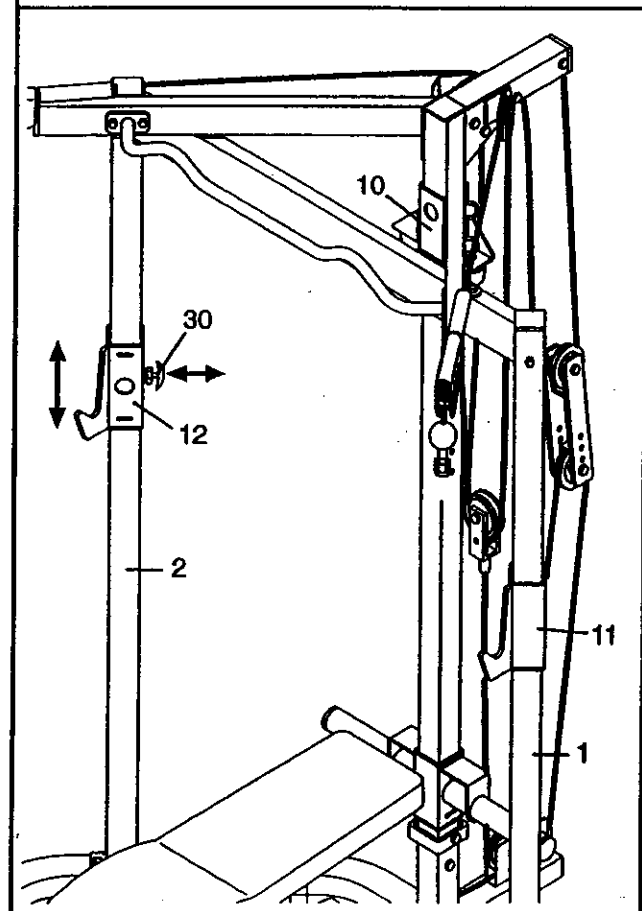

**WARNING!** Always adjust both Weight Rests (11, 12) to the same height before exercising.

## ATTACHING THE BENCH TO THE RACK

To perform bench and leg lever exercises, the weight bench must be attached to the weight rack. To attach the bench to the rack, rest the Back Leg (39) over the crossbar on the Center Base (24). **Note: Be sure that the Low Cable (59) goes through the Back Leg.** Next, attach the Bench Cable (58) to the Low Cable with a Cable Clip (28).

When the bench is not attached to the rack, use the Cable Clip (28) to attach the Bench Cable (58) to the bracket on the Back Leg (39).

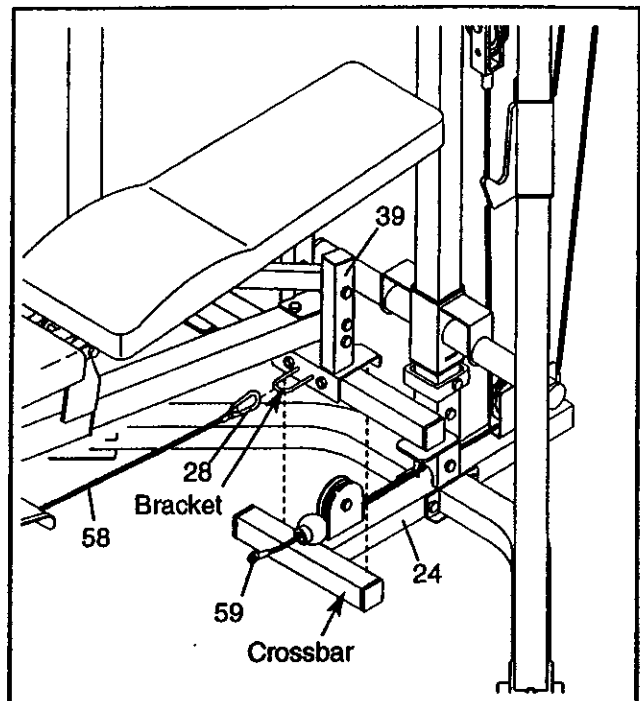

## ATTACHING A BARBELL TO THE CABLES

To use a barbell (not included) with the Safety Spotter (not shown), set the barbell on the Weight Rests (11 [not shown], 12). Slide a Barbell Ring (29) onto each end of the barbell and tighten the M8 x 12mm Screw (43). Attach each end of the High Cable (61) to the Barbell Rings with two Cable Clips (28).

**WARNING:** Use only an Olympic barbell (not included) with the Barbell Rings (29). Always disengage the barbell from the High Cable (61) when performing an exercise that does not require the barbell. The barbell should be lifted off of the weight rests and fall.

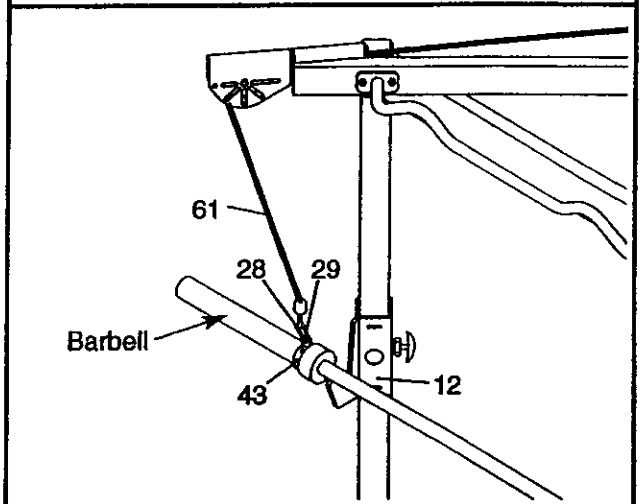

## ATTACHING WEIGHTS TO THE WEIGHT CARRIAGE OR BARBELL

Slide the desired amount of weight (not included) onto the weight tube on the Weight Carriage (25) or the barbell. Secure the weight to the Weight Carriage with Weight Clips (98).

Do not place weights on the Weight Carriage (25) when performing exercises that use the barbell.

**WARNING:** Do not place more than 150 pounds on the Weight Carriage (25). Do not place more than 200 pounds, including the barbell, on the weight rests (11, 12). Always disengage the barbell from the High Cable (61) when performing exercises that do not require the barbell. The barbell should be lifted off of the weight rests and fall.

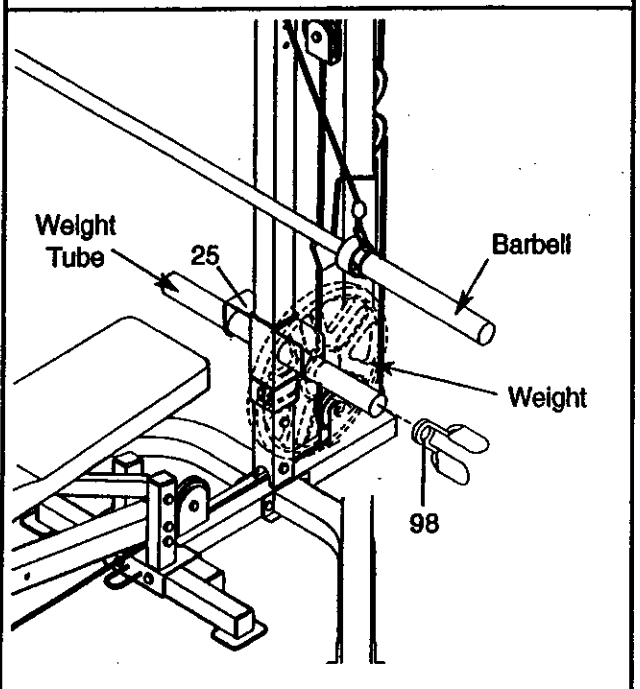

## USING THE POWER ASSIST LEGS

If you are unable to complete the repetition after performing a bench exercise, the Power Assist Legs (20, 21) can be used to help lift the barbell back to the Weight Rests (not shown).

To use the Power Assist Legs (20, 21), attach the bench to the rack and a barbell to the high cable (see ATTACHING THE BENCH TO THE RACK and ATTACHING A BARBELL TO THE CABLES on page 18). Press down on the Power Assist Legs with your feet while lifting the barbell to the Weight Rests (not shown).

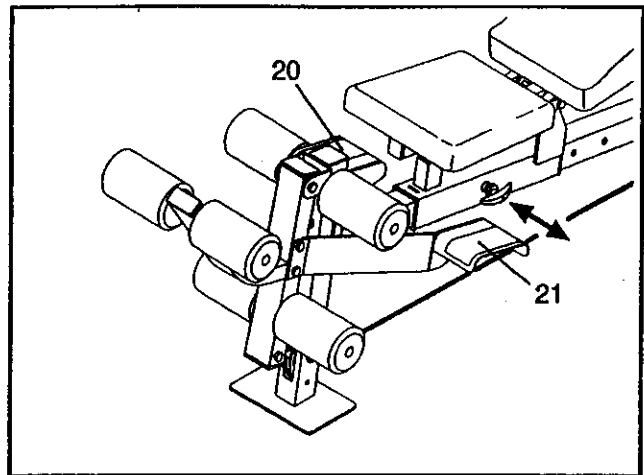

## ATTACHING THE ACCESSORIES TO THE CABLES

To use the Row Bar (38), attach it to the High Cable (61) or Low Cable (not shown) with a Cable Clip (28).

The other accessories (not shown) can be attached to the cables in the same manner.

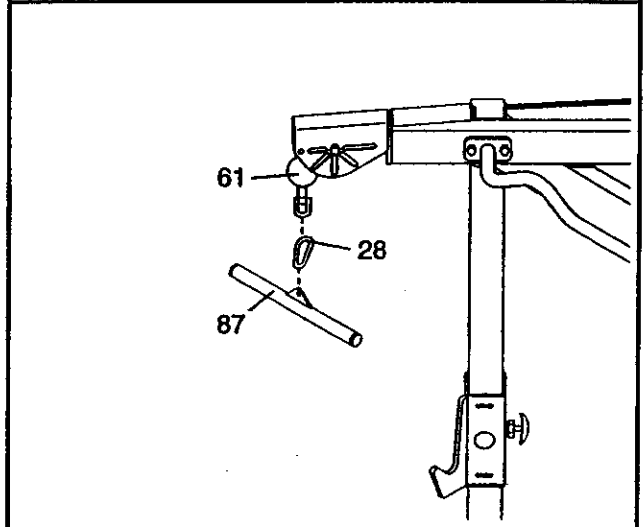

**WARNING:** Always disconnect the accessories when performing exercises that do not require them.

**Note:** The accessories can be stored on the back of the Right and Left Frames (5, 6 [not shown]) with Cable Clips (28).

## TIGHTENING THE CABLES

Woven cable, the type of cable used on the weight bench, can stretch slightly after it is first used. If there is slack in the cables, tighten them as described below.

See drawing A. Tighten the M6 Locknut (80) onto the Low Cable (59) a couple of turns.

See drawing A. Remove the M10 x 45mm Bolt (76) and the M10 Nylon Locknut (not shown) attaching the 4 1/2" Pulley (35) and Cable Trap (55) to the "U"-Bracket (33). Use the Bolt and Nylon Locknut to reattach the Pulley and Cable Trap to the lower set of holes in the "U"-Bracket.

See drawing B. Remove the M10 x 45mm Bolt (76) and the M10 Nylon Locknut (77) attaching the lower 4 1/2" Pulley (35) and Cable Trap (55) to the Pulley Plates (31). Use the Bolt and Nylon Locknut to reattach the Pulley and Cable Trap to the next set of holes in the Pulley Plates. Repeat until the cables are tight.

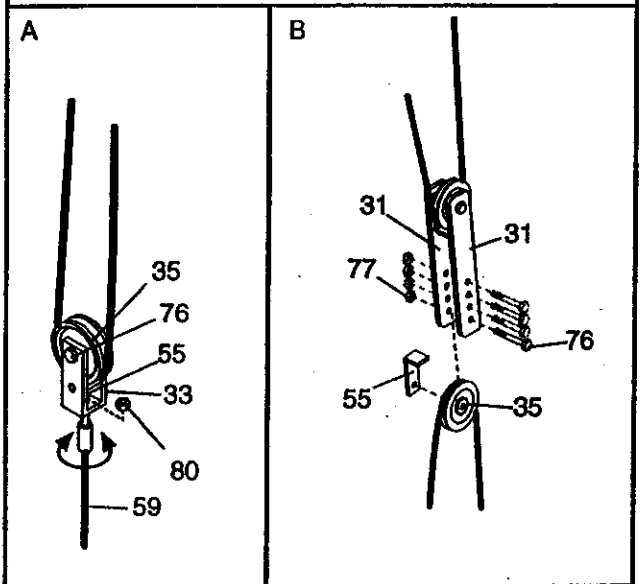

# BENCH ADJUSTMENT CHART

The chart below contains a list of exercises that require the use of the safety spotter. When preparing the weight bench for one of these exercises, follow the steps listed below. For information about each of these steps, refer to the ADJUSTMENTS section of this manual. **Make sure the bench cable is attached to the low cable when performing any of the bench exercises.**

For each exercise, determine the positions of the bench, the weight rests, and the safety spotter that are best for you. The first time you perform each exercise, write the positions of the weight rests and the safety spotter in the chart. Write the number corresponding to the height of the weight rests, and the letter corresponding to the height of the safety spotter in the appropriate column. When preparing to perform the exercise again, refer back to the chart for a quick reference to your personal settings.

## Follow these steps when preparing for each exercise:

1. Adjust the position of the bench (be sure the bench cable is attached to the low cable when performing any of the bench exercises)
2. Adjust the position of the weight rests
3. Attach your barbell to the high cable
4. Adjust the position of the safety spotter
5. Add weight to the barbell.

The first time you perform the exercises listed in the chart, note the position of the weight rests and safety spotter in the appropriate column.

### The Bench can be:

- R- removed
- D- attached in a declined position
- L- attached in a level position
- I#- attached in one of five incline positions (I1 indicates the least incline, I5 indicates fully inclined.)

### The Bench Cable can be:

- A- attached
- N- not attached

### The Weight Rests can be adjusted to positions 1-8.

Note the number of the position that is best for each exercise.

### The Safety Spotter can be adjusted to positions A-O.

Note the letter of the position that is best for each exercise.

Exercises	Bench	Bench Cable	Weight Rest	Safety Spotter
Declined Bench Press	D	A		
Bench Press	L	A		
Incline Bench Press 1	I1	A		
Incline Bench Press 2	I2	A		
Incline Bench Press 3	I3	A		
Incline Bench Press 4	I4	A		
Military Press	I5	A		
Squat	R	N		

# EXERCISE GUIDELINES

## THE FOUR BASIC TYPES OF WORKOUTS

### Muscle Building

To increase the size and strength of your muscles, push them close to their maximum capacity. Your muscles will continually adapt and grow as you progressively increase the intensity of your exercise. You can adjust the intensity level of an individual exercise in two ways:

- by changing the amount of weight used
- by changing the number of repetitions or sets performed. (A "repetition" is one complete cycle of an exercise, such as one sit-up. A "set" is a series of repetitions.)

The proper amount of weight for each exercise depends upon the individual user. You must gauge your limits and select the amount of weight that is right for you. Begin with 3 sets of 8 repetitions for each exercise you perform. Rest for 3 minutes after each set. When you can complete 3 sets of 12 repetitions without difficulty, increase the amount of weight.

### Toning

You can tone your muscles by pushing them to a moderate percentage of their capacity. Select a moderate amount of weight and increase the number of repetitions in each set. Complete as many sets of 15 to 20 repetitions as possible without discomfort. Rest for 1 minute after each set. Work your muscles by completing more sets rather than by using high amounts of weight.

### Weight Loss

To lose weight, use a low amount of weight and increase the number of repetitions in each set. Exercise for 20 to 30 minutes, resting for a maximum of 30 seconds between sets.

### Cross Training

Cross training is an efficient way to get a complete and well-balanced fitness program. An example of a balanced program is:

- Plan weight training workouts on Monday, Wednesday, and Friday.
- Plan 20 to 30 minutes of aerobic exercise, such as cycling or swimming, on Tuesday and Thursday.
- Rest from both weight training and aerobic exercise for at least one full day each week to give your body time to regenerate.

The combination of weight training and aerobic exercise will reshape and strengthen your body, and develop your heart and lungs.

## PERSONALIZING YOUR EXERCISE PROGRAM

Determining the exact length of time for each workout, as well as the number of repetitions or sets completed, is an individual matter. It is important to avoid overdoing it during the first few months of your exercise program. You should progress at your own pace and be sensitive to your body's signals. If you experience pain or dizziness at any time while exercising, stop immediately and begin cooling down. Find out what is wrong before continuing. Remember that adequate rest and a proper diet are important factors in any exercise program.

### WARMING UP

Begin each workout with 5 to 10 minutes of stretching and light exercise to warm up. Warming up prepares your body for more strenuous exercise by increasing circulation, raising your body temperature and delivering more oxygen to your muscles.

### WORKING OUT

Each workout should include 6 to 10 different exercises. Select exercises for every major muscle group, emphasizing areas that you want to develop most. To give balance and variety to your workouts, vary the exercises from session to session.

Schedule your workouts for the time of day when your energy level is the highest. Each workout should be followed by at least one day of rest. Once you find the schedule that is right for you, stick with it.

### EXERCISE FORM

Maintaining proper form is an essential part of an effective exercise program. This requires moving through the full range of motion for each exercise, and moving only the appropriate parts of the body. Exercising in an uncontrolled manner will leave you feeling exhausted. On the exercise guide accompanying this manual you will find photographs showing the correct form for several exercises, and a list of the muscles affected. Refer to the muscle chart on page 22 to find the names of the muscles.

The repetitions in each set should be performed smoothly and without pausing. The exertion stage of each repetition should last about half as long as the return stage. Proper breathing is important. Exhale during the exertion stage of each repetition and inhale during the return stroke. Never hold your breath.

Rest for a short period of time after each set. The ideal resting periods are:

- Rest for three minutes after each set for a muscle building workout.
- Rest for one minute after each set for a toning workout.
- Rest for 30 seconds after each set for a weight loss workout.

Plan to spend the first couple of weeks familiarizing yourself with the equipment and learning the proper form for each exercise.

### COOLING DOWN

End each workout with 5 to 10 minutes of stretching. Include stretches for both your arms and legs. Move

slowly as you stretch and do not bounce. Ease into each stretch gradually and go only as far as you can without strain. Stretching at the end of each workout is an effective way to increase flexibility.

### STAYING MOTIVATED

For motivation, keep a record of each workout. The chart on page 23 of this manual can be photocopied and used to schedule and record your workouts. List the date, the exercises performed, the weight used, and the numbers of sets and repetitions completed. Record your weight and key body measurements at the end of every month. Remember, the key to achieving the greatest results is to make exercise a regular and enjoyable part of your everyday life.

### MUSCLE CHART

- A. Sternomastoid (neck)
- B. Pectoralis Major (chest)
- C. Biceps (front of arm)
- D. Obliques (waist)
- E. Brachioradials (forearm)
- F. Hip Flexors (upper thigh)
- G. Abductor (outer thigh)
- H. Quadriceps (front of thigh)
- I. Sartorius (front of thigh)
- J. Tibialis Anterior (front of calf)
- K. Soleus (front of calf)
- L. Rectus Abdominus (stomach)
- M. Adductor (inner thigh)
- N. Trapezius (upper back)
- O. Rhomboideus (upper back)
- P. Deltoid (shoulder)
- Q. Triceps (back of arm)
- R. Latissimus Dorsi (mid back)
- S. Spinae Erectors (lower back)
- T. Gluteus Medius (hip)
- U. Gluteus Maximus (buttocks)
- V. Hamstring (back of leg)
- W. Gastrocnemius (back of calf)

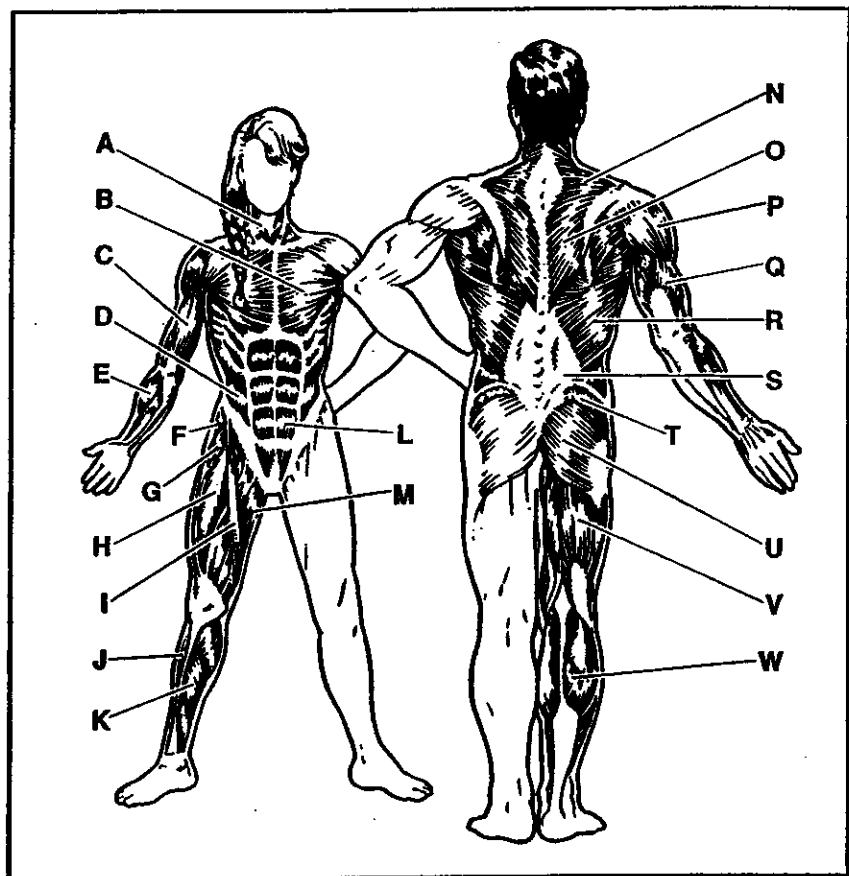

**MONDAY**

Date:

\_ / \_ / \_

EXERCISE	WEIGHT	SETS	REPS

**TUESDAY****AEROBIC EXERCISE**

Date:

\_ / \_ / \_

**WEDNESDAY**

Date:

\_ / \_ / \_

EXERCISE	WEIGHT	SETS	REPS

**THURSDAY****AEROBIC EXERCISE**

Date:

\_ / \_ / \_

**FRIDAY**

Date:

\_ / \_ / \_

EXERCISE	WEIGHT	SETS	REPS

Make photocopies of this page for scheduling and recording your workouts.

**REMOVE THIS PART LIST/EXPLODED  
DRAWING FROM THE MANUAL**

**SAVE THIS PART LIST/EXPLODED DRAWING FOR FUTURE REFERENCE**

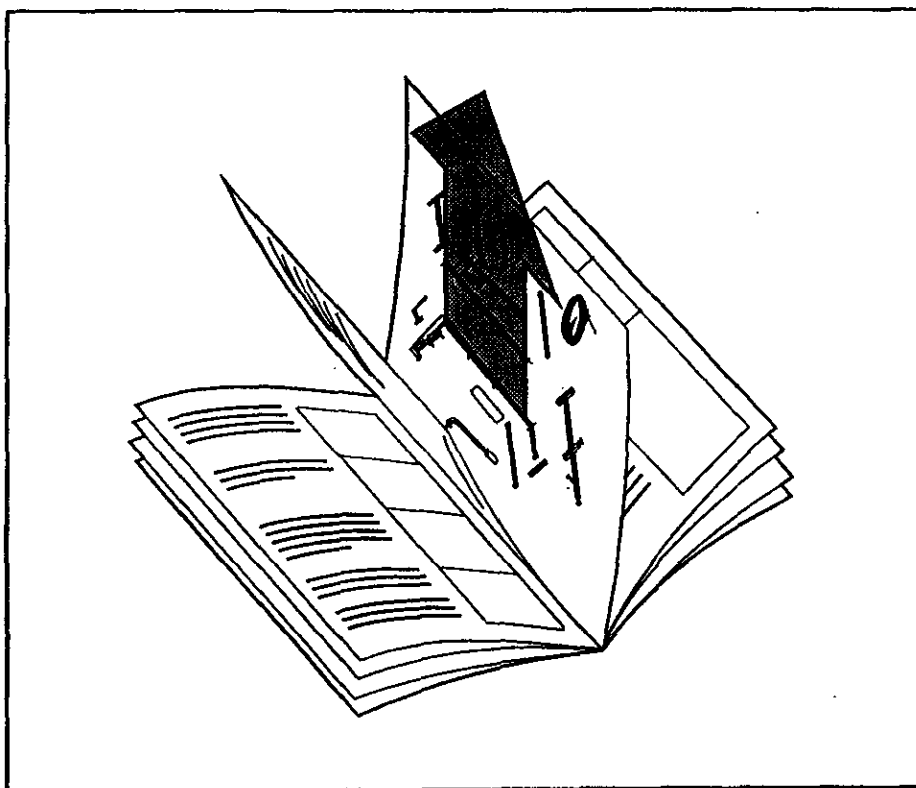



# EXPLODED DRAWING—Model No. 831.153230

R1201A

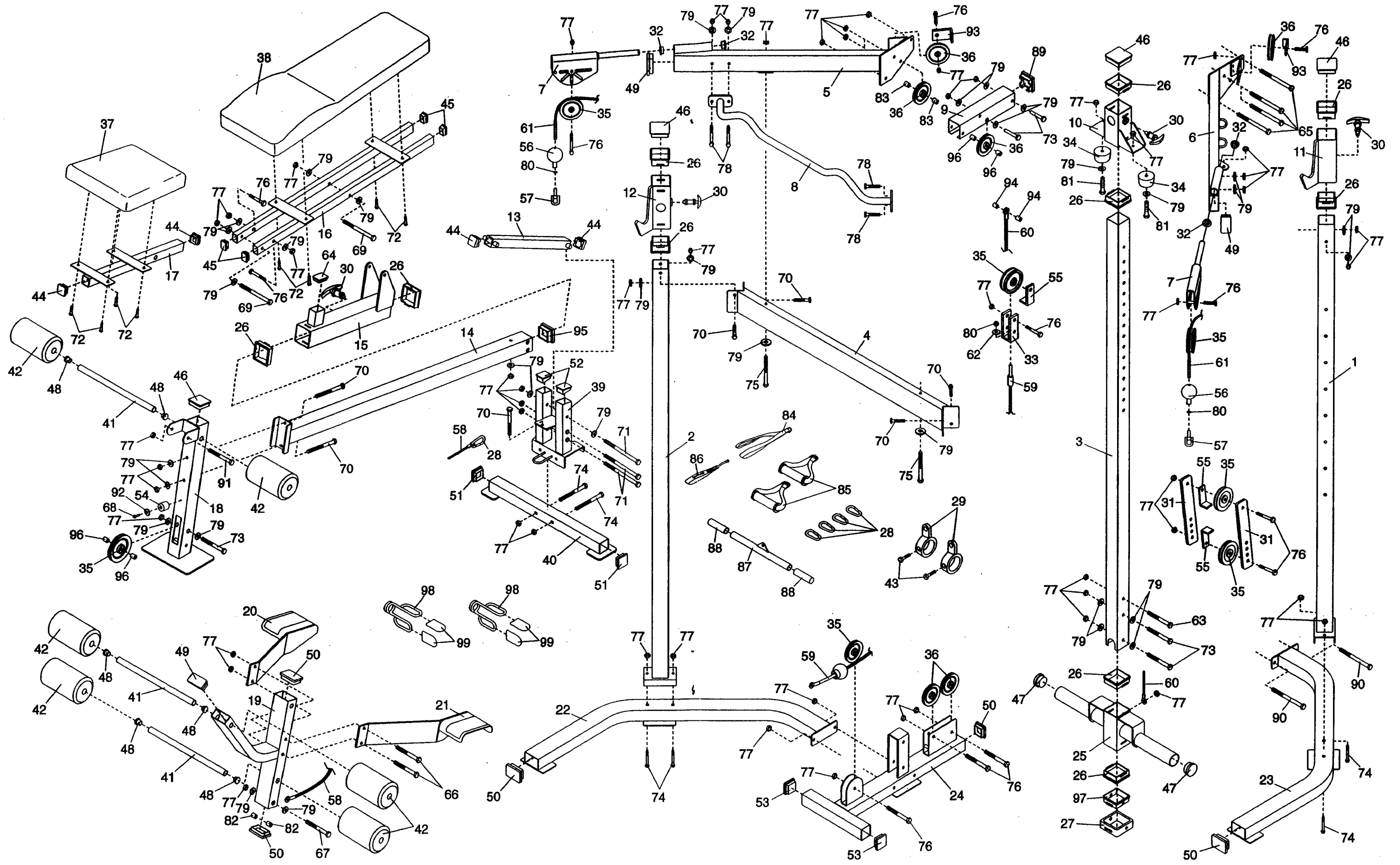

# PART LIST—Model No. 831.153230

R1201A

Key No.	Qty.	Description	Key No.	Qty.	Description
1	1	Left Upright	52	2	38mm x 50mm Angled Inner Cap
2	1	Right Upright	53	2	50mm Thick Square Inner Cap
3	1	Center Upright	54	1	Leg Lever Bumper
4	1	Center Frame	55	3	Large Cable Trap
5	1	Right Frame	56	2	Cable Ball
6	1	Left Frame	57	2	Cable Eye
7	2	Pulley Arm	58	1	Bench Cable
8	1	Pull-up Bar	59	1	Low Cable
9	1	Top Frame	60	1	Carriage Cable
10	1	Safety Spotter	61	1	High Cable
11	1	Left Weight Rest	62	1	M6 Washer
12	1	Right Weight Rest	63	1	M10 x 86mm Bolt
13	1	Support Leg	64	1	38mm x 50mm Inner Cap
14	1	Bench Frame	65	4	M10 x 81mm Bolt
15	1	Sliding Seat Frame	66	2	M10 x 100mm Bolt
16	1	Backrest Frame	67	1	M10 x 91mm Bolt
17	1	Seat Frame	68	1	M4 x 19mm Screw
18	1	Front Leg	69	2	M10 x 154mm Bolt
19	1	Leg Lever	70	7	M10 x 78mm Bolt
20	1	Right Power Assist Leg	71	3	M10 x 164mm Bolt
21	1	Left Power Assist Leg	72	8	M6 x 16mm Bolt
22	1	Right Base	73	5	M10 x 75mm Bolt
23	1	Left Base	74	6	M10 x 62mm Carriage Bolt
24	1	Center Base	75	2	M10 x 120mm Bolt
25	1	Weight Carriage	76	12	M10 x 45mm Bolt
26	10	75mm Bushing	77	55	M10 Nylon Locknut
27	1	Carriage Stop	78	4	M10 x 57mm Bolt
28	5	Cable Clip	79	35	M10 Washer
29	2	Barbell Ring	80	3	M6 Locknut
30	4	Knob	81	2	M10 x 25mm Button Bolt
31	2	Pulley Plate	82	2	35mm Spacer
32	4	Pulley Arm Bushing	83	2	15mm Spacer
33	1	"U"-Bracket	84	1	Ab Strap
34	2	Safety Spotter Bumper	85	2	Handle
35	7	4 1/2" Pulley	86	1	Ankle Strap
36	6	88mm Pulley	87	1	Row Bar
37	1	Seat	88	2	Row Bar Grip
38	1	Backrest	89	1	60mm Square Arched Cap
39	1	Back Leg	90	2	M10 x 97mm Bolt
40	1	Stabilizer	91	1	M10 x 102mm Bolt
41	3	Pad Tube	92	1	M5 Washer
42	6	Foam Pad	93	2	Small Cable Trap
43	2	M8 x 12mm Screw	94	2	27mm Spacer
44	4	38mm Square Inner Cap	95	1	60mm Square Angled Cap
45	4	25.4mm x 38.1mm Inner Cap	96	4	17mm Spacer
46	4	60mm Square Inner Cap	97	1	75mm Bushing (PP Material)
47	2	2" Round Inner Cap	98	2	Weight Clip
48	6	19mm Round Inner Cap	99	4	Weight Clip Sleeve
49	3	38.1mm x 76.2mm Inner Cap	#	1	User's Manual
50	5	2" x 3" Inner Cap	#	1	Exercise Guide
51	2	50mm Square Inner Cap			

Note: "#" indicates a non-illustrated part. Specifications are subject to change without notice. See the back cover of the user's manual for information about ordering replacement parts.

**Model No. 831.153230**

## **QUESTIONS?**

**If you find that:**

- **you need help assembling or operating the WEIDER® PRO 575**
- **a part is missing**
- **or you need to schedule repair service**

**call our toll-free HELPLINE**

**1-800-736-6879**

**Monday-Saturday, 7 am-7 pm  
Central Time (excluding holidays)**

## **REPLACEMENT PARTS**

**If parts become worn and need to be replaced, call the following toll-free number**

**1-800-FON-PART  
(1-800-366-7278)**

The model number and serial number of your WEIDER® PRO 575 are listed on a decal attached to the frame. See the front cover of this manual to find the location of the decal.

All replacement parts are available for immediate purchase or special order when you visit your nearest SEARS Service Center. To request service or to order parts by telephone, call the toll-free numbers listed at the left.

When requesting help or service, or ordering parts, please be prepared to provide the following information:

- The **MODEL NUMBER** of the product (831.153230)
- The **NAME** of the product (WEIDER® PRO 575 weight bench)
- The **PART NUMBER** and **DESCRIPTION** of the part (see the **PART LIST** and the **EXPLODED DRAWING** in the center of this manual).

**SEARS, ROEBUCK AND CO., HOFFMAN ESTATES, IL 60179**

---

## **FULL 90 DAY WARRANTY**

For 90 days from the date of purchase, if failure occurs due to defect in material or workmanship in this SEARS WEIGHT BENCH EXERCISER, contact the nearest SEARS Service Center throughout the United States and SEARS will repair or replace the WEIGHT BENCH EXERCISER, free of charge.

This warranty does not apply when the WEIGHT BENCH EXERCISER is used commercially or for rental purposes.

This warranty gives you specific legal rights, and you may also have other rights which vary from state to state.

**SEARS, ROEBUCK AND CO., DEPT. 817WA, HOFFMAN ESTATES, IL 60179**