



# 920 S EKG

## USER'S MANUAL

Model No. 831.280170

Serial No. \_\_\_\_\_

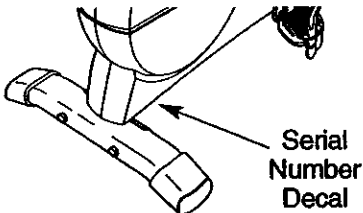

**EXERCISE  
EQUIPMENT**

**QUESTIONS**

**HELPLINE!**

**1-800-736-6879**

**SEARS, ROEBUCK AND CO.,  
HOFFMAN ESTATES, IL 60179**

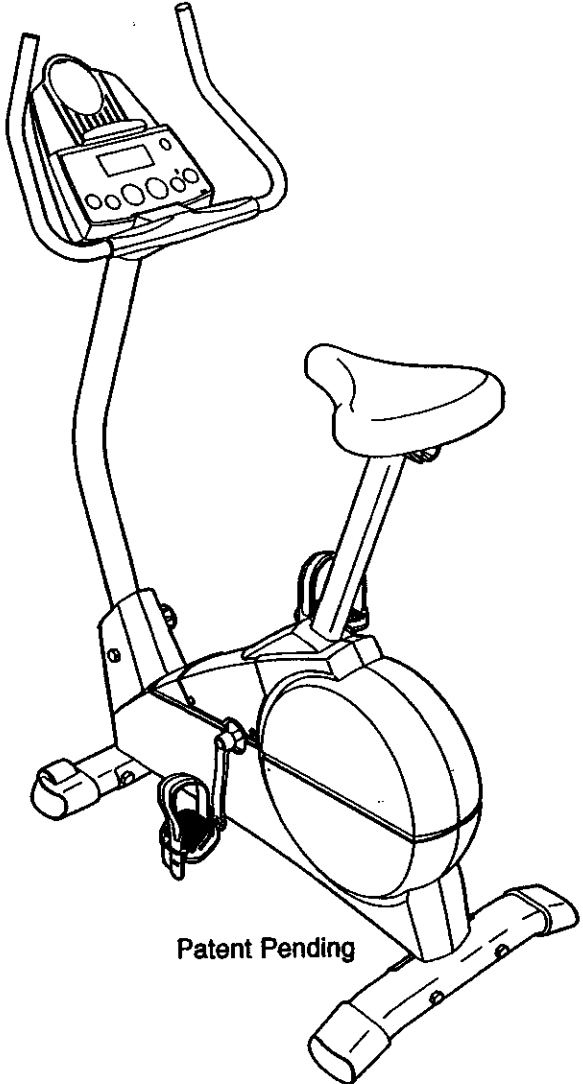

Patent Pending



**[www.proform.com](http://www.proform.com)**  
*new products, prizes,  
fitness tips, and much more!*

**! CAUTION**  
This exercise bike is not intended for use by individuals with heart disease, high blood pressure, or other medical conditions. Consult your physician before using this exercise bike. Do not use this exercise bike if you are pregnant, have a recent injury, or are recovering from surgery. Use this exercise bike only on a hard, level surface. Do not use this exercise bike on carpet or other soft surfaces. Do not use this exercise bike if you are under the influence of alcohol or drugs. Do not use this exercise bike if you are feeling dizzy, lightheaded, or otherwise unwell. Do not use this exercise bike if you are experiencing chest pain, shortness of breath, or any other symptoms of a heart attack. Do not use this exercise bike if you are experiencing any other symptoms of a medical emergency. Do not use this exercise bike if you are experiencing any other symptoms of a medical emergency. Do not use this exercise bike if you are experiencing any other symptoms of a medical emergency.

# TABLE OF CONTENTS

IMPORTANT PRECAUTIONS .....	2
BEFORE YOU BEGIN .....	3
ASSEMBLY .....	4
HOW TO OPERATE THE EXERCISE CYCLE .....	8
MAINTENANCE AND TROUBLE-SHOOTING .....	11
CONDITIONING GUIDELINES .....	12
PART LIST .....	14
EXPLODED DRAWING .....	15
HOW TO ORDER REPLACEMENT PARTS .....	Back Cover
FULL 90 DAY WARRANTY .....	Back Cover

## IMPORTANT PRECAUTIONS

**! WARNING:** To reduce the risk of serious injury, read the following important precautions before using the exercise cycle.

1. Read all instructions in this manual before using the exercise cycle.
2. It is the responsibility of the owner to ensure that all users of the exercise cycle are fully and quickly informed of all precautions. Use the exercise cycle only as described in this manual.
3. Use the exercise cycle indoors on a level surface. Keep the exercise cycle away from moisture and dust. Place a mat under the exercise cycle to protect the floor.
4. Inspect and properly tighten all parts regularly. Replace any worn parts immediately.
5. Keep children away from the front of the exercise cycle at all times.
6. Wear appropriate clothing when exercising. Do not wear loose clothing that could become caught on the exercise cycle. Always wear athletic shoes for foot protection.
7. The exercise cycle should not be used by persons weighing more than 250 pounds.
8. Always keep your back straight when using the exercise cycle to help with your back.
9. If you feel pain or dizziness while exercising, stop immediately and rest.
10. The exercise cycle has a safety stop. If you stop the pedals will continue to move until the flywheel stops.
11. The pulse sensor is not a medical device. Always follow instructions for use and consult your physician if you have any concerns. The pulse sensor is not intended as a substitute for medical advice or diagnosis in general.
12. The exercise cycle is intended for home use only. Do not use the exercise cycle for commercial, industrial, or other non-home use.

**! WARNING:** To reduce the risk of injury, use the exercise cycle only as directed in this manual. Do not use the exercise cycle for commercial, industrial, or other non-home use. The exercise cycle is not intended for use by persons with pre-existing medical conditions or who are recovering from an injury. Consult your physician before using the exercise cycle. The exercise cycle is not intended for use by persons who are pregnant or who are recovering from a pregnancy. The exercise cycle is not intended for use by persons who are under the influence of alcohol or drugs. The exercise cycle is not intended for use by persons who are taking medication for high blood pressure, heart disease, or other medical conditions. The exercise cycle is not intended for use by persons who are taking medication for depression or other mental health conditions. The exercise cycle is not intended for use by persons who are taking medication for diabetes or other chronic conditions. The exercise cycle is not intended for use by persons who are taking medication for asthma or other respiratory conditions. The exercise cycle is not intended for use by persons who are taking medication for thyroid disease or other endocrine conditions. The exercise cycle is not intended for use by persons who are taking medication for epilepsy or other neurological conditions. The exercise cycle is not intended for use by persons who are taking medication for cancer or other serious medical conditions. The exercise cycle is not intended for use by persons who are taking medication for HIV/AIDS or other infectious diseases. The exercise cycle is not intended for use by persons who are taking medication for any other medical condition. The exercise cycle is not intended for use by persons who are taking medication for any other medical condition.

# BEFORE YOU BEGIN

Congratulations for selecting the new PROFORM® 920 S EKG exercise cycle. Cycling is one of the most effective exercises for increasing cardiovascular fitness, building endurance, and toning the entire body. The PROFORM® 920 S EKG offers an impressive array of features to let you enjoy this healthful exercise in the convenience and privacy of your home.

**For your benefit, read this manual carefully before you use the exercise cycle.** If you have questions after reading the manual, please call our toll-free

HELPLINE at 1-800-736-6879, Monday through Saturday, 7 a.m. until 7 p.m. Central Time (excluding holidays). To help us assist you, please note the product model number and serial number before calling. The model number is 831.280170. The serial number can be found on a decal attached to the exercise cycle (see the front cover of this manual).

Before reading further, please familiarize yourself with the parts that are labeled in the drawing below.

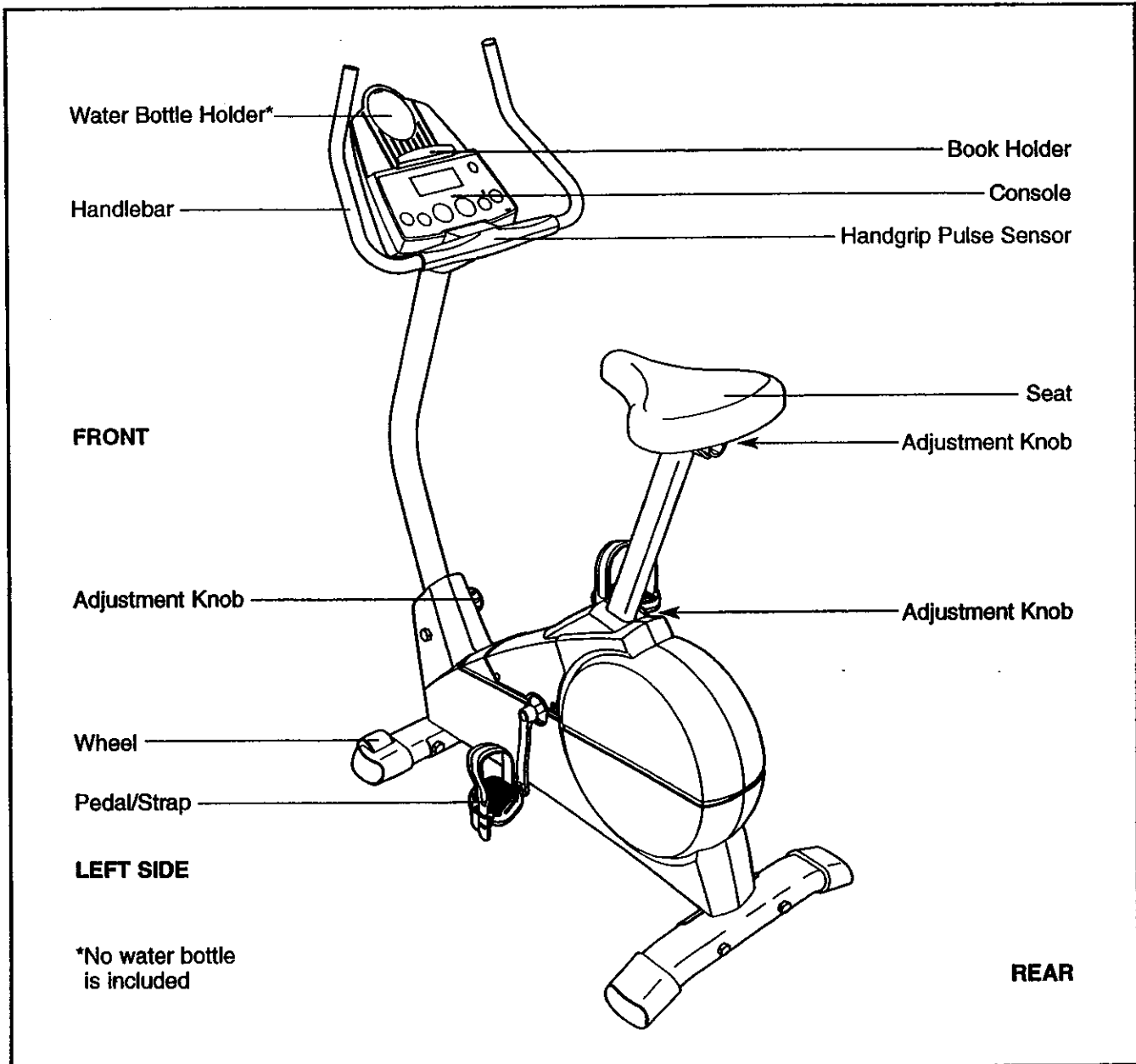

# ASSEMBLY

**Assembly requires two persons.** Place all parts of the exercise cycle in a cleared area and remove the packing materials. Do not dispose of the packing materials until assembly is completed.

**Assembly requires the included tools and your own adjustable wrench  and Phillips screwdriver .**

Use the part drawings below to identify the small parts used in assembly. The number in parenthesis below each drawing refers to the key number of the part, from the PART LIST on page 14. The second number refers to the quantity needed for assembly. **Note: Some small parts may have been pre-attached for shipping. If a part is not in the parts bag, check to see if it has been pre-attached.**

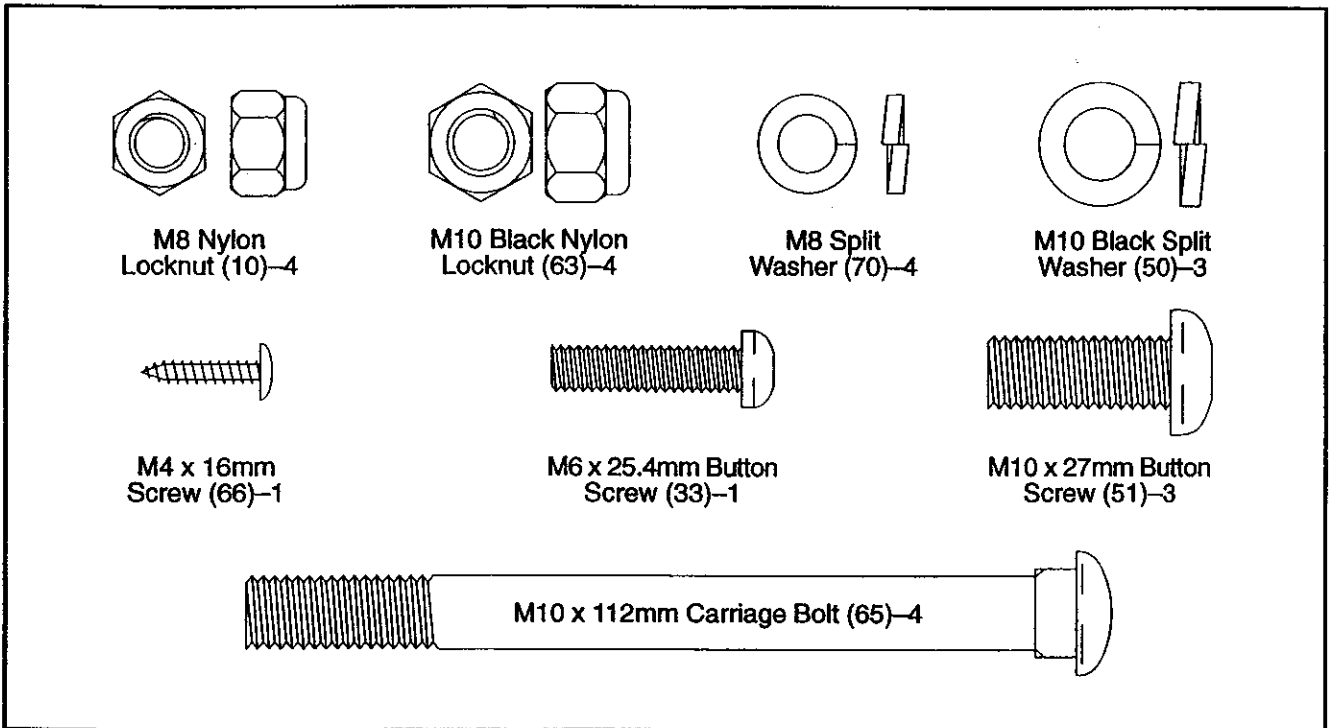

1. Identify the Front Stabilizer (2), which has Wheels (30) on the ends. While another person lifts the front of the Frame (1) slightly, attach the Front Stabilizer to the Frame with two M10 x 112mm Carriage Bolts (65) and two M10 Black Nylon Locknuts (63). **Make sure that the Front Stabilizer is turned so the Wheels are not touching the floor.**

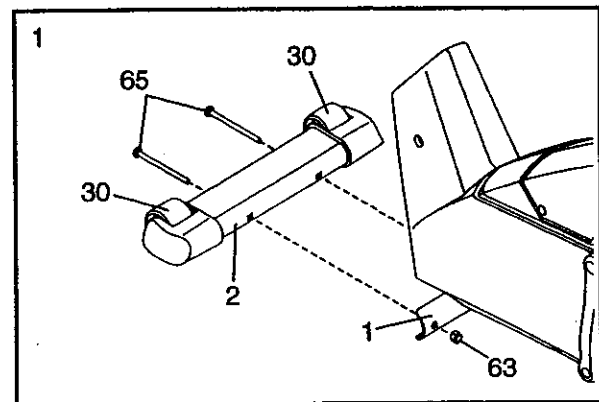

2. While another person lifts the back of the Frame (1) slightly, attach the Rear Stabilizer (3) to the Frame with two M10 x 112mm Carriage Bolts (65) and two M10 Black Nylon Locknuts (63).

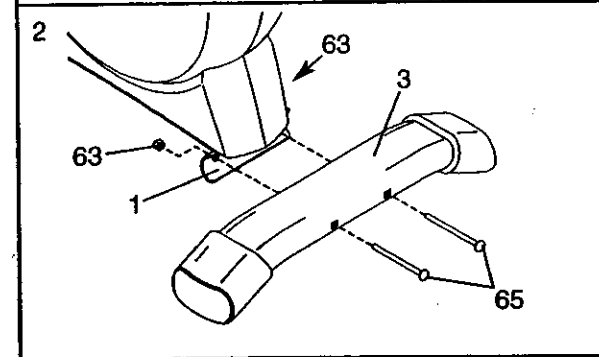

3. While another person holds the Upright (13) in the position shown, connect the Upper Wire Harness (36) to the Lower Wire Harness (35). **Carefully pull the upper end of the Upper Wire Harness to remove any slack from the Wire Harnesses; make sure that the connectors do not catch on the indicated rod.**

Turn the indicated Adjustment Knob (28) counterclockwise two or three turns to loosen it. Next, pull the Knob, insert the Upright (13) into the Frame (1), and then release the Knob. **Be careful to avoid pinching the Wire Harnesses (35, 36). Move the Upright up and down slightly until the pin on the Knob snaps into one of the holes in the Upright.** Then, turn the Knob clockwise until it is tight.

Tighten the M6 x 25.4mm Button Screw (33) into the Frame (1) and into the slot in the side of the Upright (13).

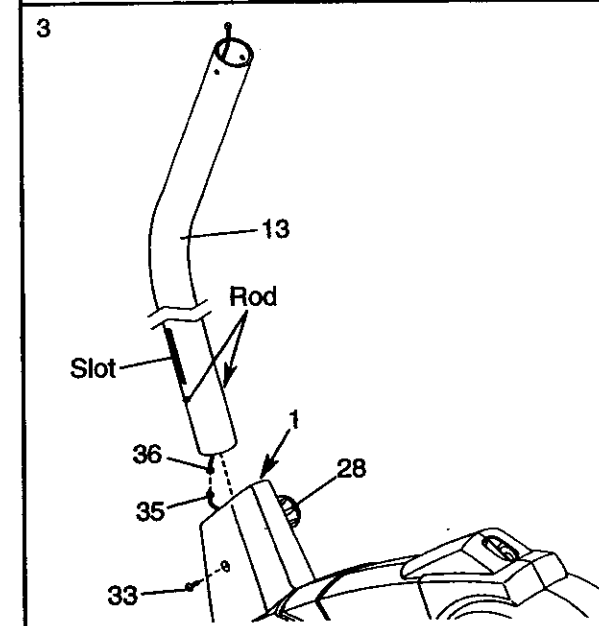

4. The Console (16) requires four "D" batteries (not included); alkaline batteries are recommended. Press the tab on the battery cover, and lift off the battery cover. Insert four batteries into the battery compartment. **Make sure that the batteries are oriented as shown by the markings inside the battery compartment.** Reattach the battery cover.

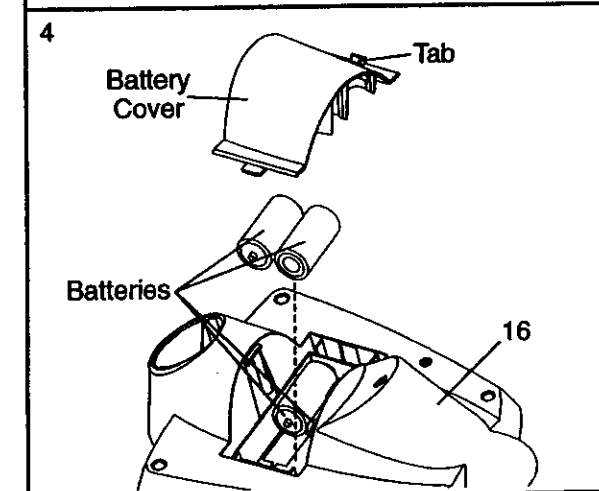

5. Connect the wire harness on the Handgrip Pulse Sensor (15) to the indicated wire harness on the Console (16). Insert both wire harnesses into the opening in the bottom of the Console. Then, insert the metal tube on the Handgrip Pulse Sensor into the opening in the bottom of the console. **Be careful not to pinch the wire harnesses.**

Refer to the inset drawing. Tighten an M4 x 16mm Screw (66) into the indicated bracket on the Console (16) and into the metal tube on the Handgrip Pulse Sensor (15).

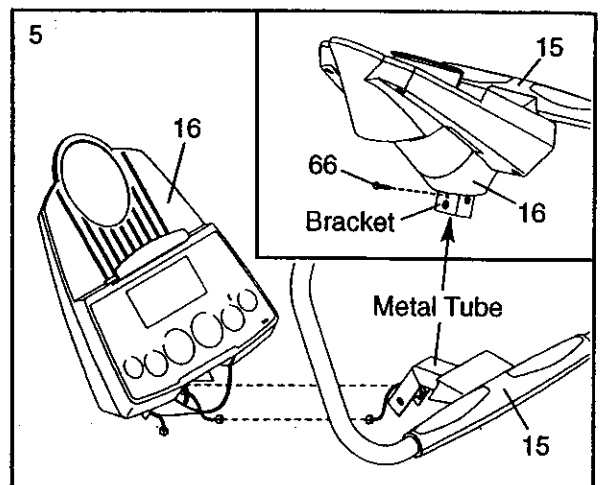

6. While another person holds the Console (16) in the position shown, connect the wire harness on the Console to the Upper Wire Harness (36). Insert the excess wire harness into the Upright (13).

Attach the Console (16) to the Upright (13) with three M10 x 27mm Button Screws (51) and three M10 Black Split Washers (50). **Be careful to avoid pinching the wire harnesses.**

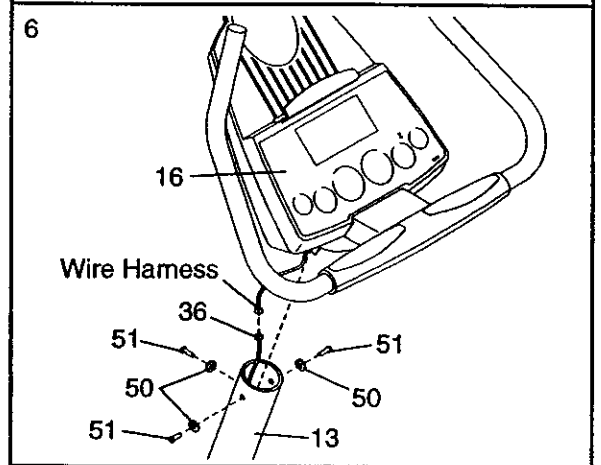

7. Turn the indicated Adjustment Knob (28) counterclockwise two or three turns to loosen it. Next, pull the Knob, insert the Seat Post (5) into the Frame (1), and then release the Knob. **Move the Seat Post up and down slightly until the pin on the Knob snaps into one of the holes in the Seat Post.** Then, turn the Knob clockwise until it is tight.

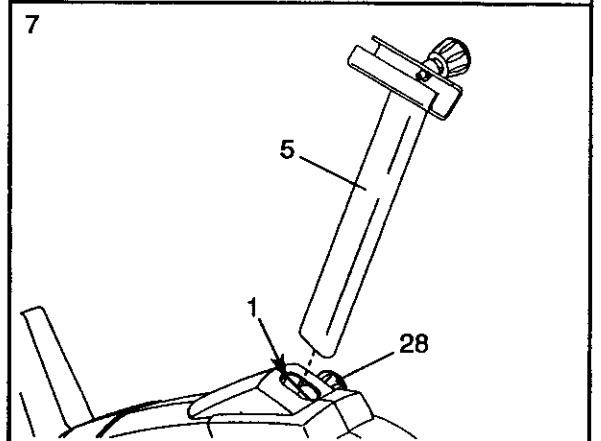

8. Attach the Seat (12) to the Seat Bracket (6) with four M8 Nylon Locknuts (10) and four M8 Split Washers (70). **Note: The Nylon Locknuts and the Split Washers may be pre-attached to the underside of the Seat.**

Turn the Seat Adjustment Knob (9) counterclockwise two or three turns to loosen it. Next, pull the Knob, slide the Seat Bracket (6) into the top of the Seat Post (5), and then release the Knob. **Move the Seat Bracket forward and backward slightly until the pin on the Knob snaps into one of the holes in the Seat Bracket.** Then, turn the Knob clockwise until it is tight.

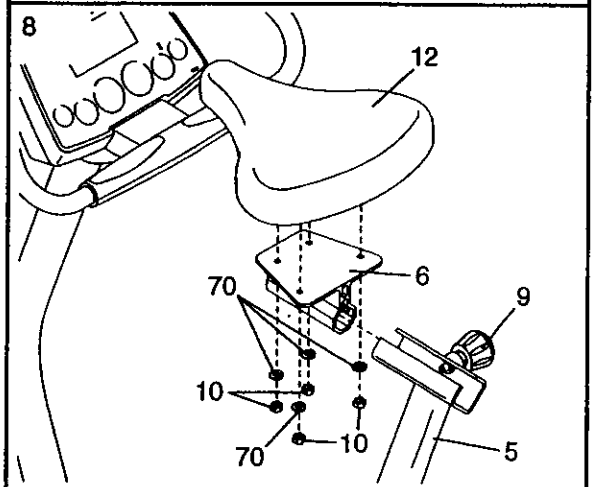

9. Identify the Left Pedal (24), which is marked with an "L." Using an adjustable wrench, **firmly tighten** the Left Pedal *counterclockwise* into the Left Crank Arm (42). Tighten the Right Pedal (not shown) *clockwise* into the Right Crank Arm. **Important: Tighten both Pedals as firmly as possible. After using the exercise cycle for one week, retighten the Pedals. For best performance, the Pedals must be kept tightened.**

Adjust the Left Pedal Strap (25) to the desired position, and press the end of the Pedal Strap onto the tab on the Left Pedal (24). Adjust the Right Pedal Strap (not shown) in the same way.

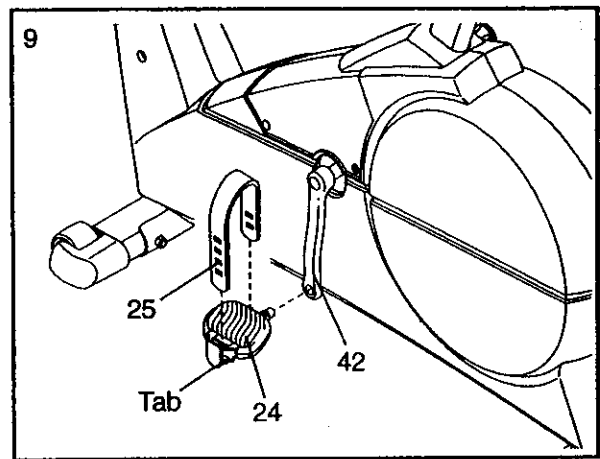

10. **Make sure that all parts are properly tightened before you use the exercise cycle.** Note: After assembly is completed, some extra parts may be left over. Place a mat beneath the exercise cycle to protect the floor.

# HOW TO OPERATE THE EXERCISE CYCLE

## HOW TO ADJUST THE SEAT POST

For effective exercise, the seat should be at the proper height. As you pedal, there should be a slight bend in your knees when the pedals are in the lowest position. To adjust the height of the seat, first turn the indicated knob counterclockwise two or three turns to loosen it (if the knob is not loosened enough, it may scratch the seat post). Next, pull the knob, slide the seat post to the desired height, and then release the knob. **Move the seat post up and down slightly until the pin on the knob snaps into one of the holes in the seat post.** Then, turn the knob clockwise until it is tight.

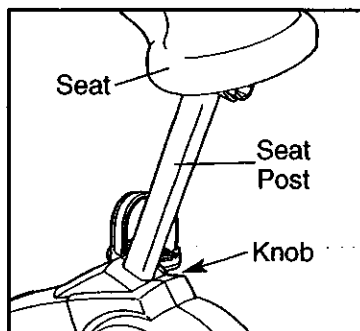

## HOW TO ADJUST THE UPRIGHT

The upright can be adjusted to the height that is the most comfortable for you. To adjust the upright, first turn the indicated knob counterclockwise two or three turns to loosen it (if the knob is not loosened enough, it may scratch the upright). Next, pull the knob, slide the upright to the desired height, and then release the knob. **Move the upright up and down slightly until the pin on the knob snaps into one of the holes in the upright.** Then, turn the knob clockwise until it is tight.

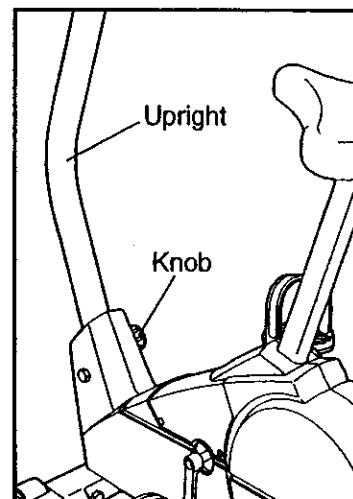

## HOW TO ADJUST THE SEAT

The seat can be adjusted to the position that is the most comfortable for you. **Before adjusting the seat, dismount the exercise cycle; do not adjust the seat while you are sitting on it.** To adjust the seat, first turn the indicated knob counterclockwise two or three turns to loosen it (if the knob is not loosened enough, it may scratch the seat bracket). Next, pull the knob, slide the seat to the desired position, and then release the knob. **Move the seat bracket forward and backward slightly until the pin on the knob snaps into one of the holes in the seat bracket.** Then, turn the knob clockwise until it is tight.

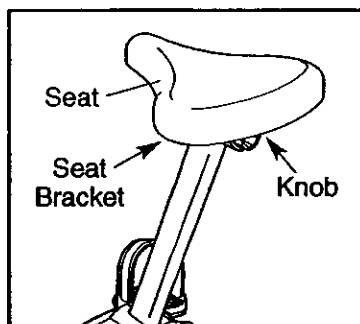

## HOW TO ADJUST THE PEDAL STRAPS

To adjust the pedal straps, first pull the ends of the straps off the tabs on the pedals. Adjust the straps to the desired position, and press the ends of the straps back onto the tabs.

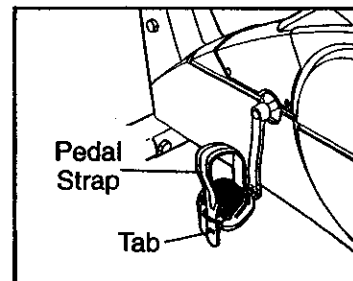



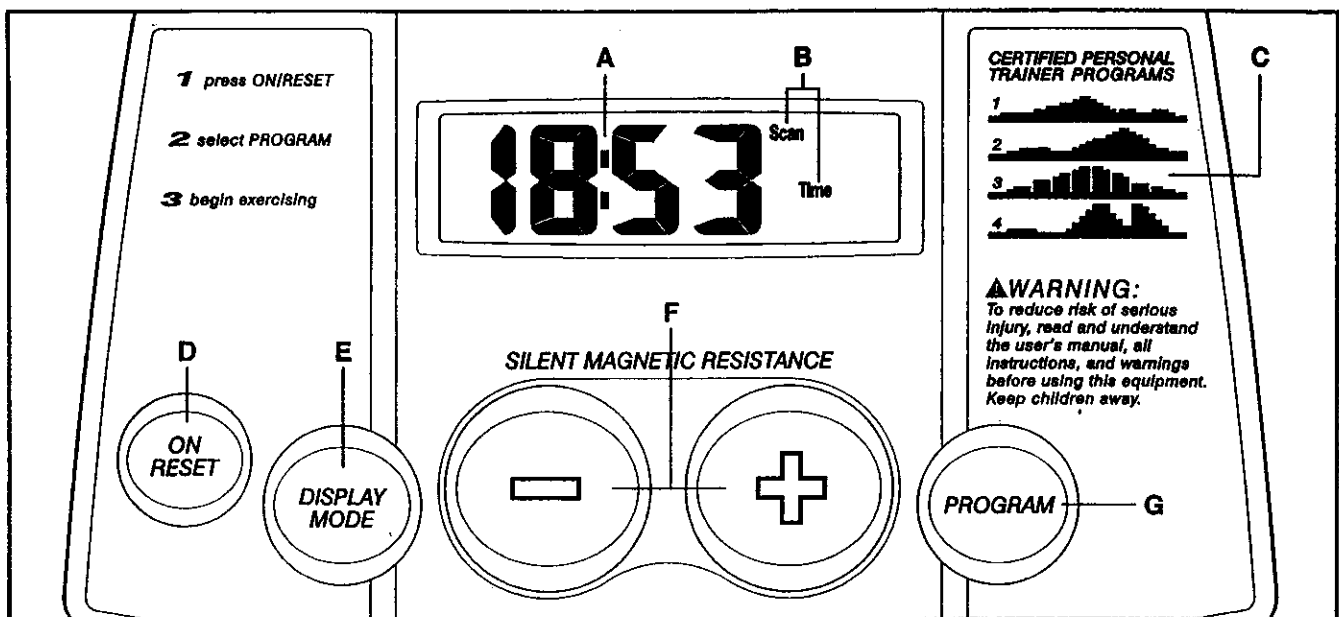

## FEATURES OF THE CONSOLE

The easy-to-use console offers a selection of features designed to help you get the most from your workouts. When the manual mode of the console is selected, the resistance of the exercise cycle can be adjusted with a touch of a button. As you exercise, the console will provide continuous exercise feedback. You can even measure your heart rate using the handgrip pulse sensor. The console also offers four certified personal trainer programs. Each program automatically controls the resistance of the exercise cycle as it guides you through an effective workout.

## CONSOLE DESCRIPTION

Refer to the drawing above. **Note: If there is a thin sheet of plastic on the face of the console, remove it.**

**A. Display**—The display features seven modes that show your current speed, the elapsed time (or the time remaining in a personal trainer program), the distance that you have pedaled, the resistance level, the approximate numbers of calories and fat calories you have burned (see **FAT BURNING** on page 13), and your heart rate (when you use the handgrip pulse sensor).

**Note: The console can show speed and distance in either miles or kilometers. To change the unit of measurement, hold down the On/Reset button for six seconds. The mode indicators (see B at the right) will show which unit of measurement is**

**selected. When the batteries are replaced, it may be necessary to reselect the desired unit of measurement.**

**B. Display mode indicators**—These indicators show which display mode is currently shown (scan, speed, time, distance, resistance level, calories, fat calories, or heart rate). **Note:** When the distance is shown, the word Miles or the letters Kms will appear; when your speed is shown, the letters MPH or Km/H will appear.

**C. Program profiles**—These profiles show how the resistance of the exercise cycle will change during personal trainer programs.

**D. On/Reset button**—When the console is off, pressing this button will turn on the display. When the console is on, pressing this button will reset the display. This button is also used to select the unit of measurement for speed and distance (see A at the left).

**E. Display Mode button**—This button is used to select the display modes. The modes will be selected in the following order: scan, speed, time, distance, resistance level, calories, fat calories, and heart rate (when the handgrip pulse sensor is used).

**F. + and - buttons**—These buttons control the resistance of the exercise cycle.

**G. Program button**—This button is used to select the manual mode and personal trainer programs.

# HOW TO USE THE CONSOLE

## 1 Turn on the console.

Note: The console requires four "D" batteries (not included). If you have not installed batteries, refer to step 4 on page 5 and install batteries.

To turn on the console, press the On/Reset button or begin pedaling.

## 2 Select the manual mode.

Each time the console is turned on, the manual mode will automatically be selected. If a personal trainer program has been selected, you can select the manual mode by pressing the Program button repeatedly until a "P 4" appears in the display and then pressing the Program button once more.

## 3 Begin exercising and adjust the resistance of the exercise cycle.

As you exercise, adjust the resistance of the exercise cycle as desired by pressing the + and - buttons. There are ten resistance levels; level 10 is the most challenging. Note: After the buttons are pressed, it will take a few seconds for the selected setting to be reached.

## 4 Follow your progress with the display.

When the console is turned on, the scan mode will be selected. As you exercise, the display will

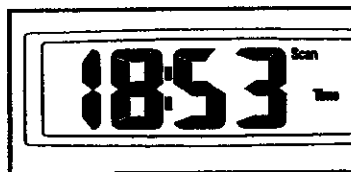

show your current speed, the elapsed time, the distance that you have pedaled, the current resistance level, and the approximate numbers of calories and fat calories you have burned (see FAT BURNING on page 13). In addition, your heart rate will be shown when you use the handgrip pulse sensor (refer to step 5 at the right). The display will change from one mode to the next every six seconds. Note: Each time the resistance level changes, the console will show the resistance level for six seconds. When a per-

sonal trainer program is selected, the display will show the *time remaining* in the program instead of the elapsed time.

If desired, you can select a single mode for continuous display. Press the Display Mode button repeatedly until only the MPH (or Km/H), Time, Miles (or Kms), Resist., Cals., or Fat Cals. indicator appears in the display. Make sure that the Scan indicator does not appear.



## 5 Measure your heart rate if desired.

Note: If there are thin sheets of plastic on the metal contacts on the handgrip pulse sensor, peel off the plastic.

To use the handgrip pulse sensor, place your hands on the metal contacts. Your palms must be on the upper contacts and your fingers must be touching the lower contacts. Avoid moving your hands. When your pulse is detected, the heart-shaped indicator in the display will flash each time your heart beats. After a moment, two dashes (--) will appear and then your heart rate will be shown.

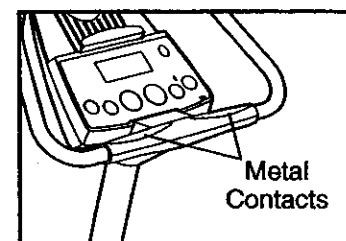

For the most accurate heart rate reading, continue to hold the handgrips for about 15 seconds. Note: When you first hold the handgrips, the display will show your heart rate continuously for 15 seconds. The display will then show your heart rate along with the other feedback modes.

## 6 When you are finished exercising, the console will automatically turn off after five minutes.

If the pedals are not moved and the console buttons are not pressed for five minutes, the console will automatically turn off to conserve the batteries.



**1 Turn on the console.**

Refer to step 1 on page 10.

**2 Select one of the four personal trainer programs.**

Each time the console is turned on, the manual mode will be selected. To select a personal trainer

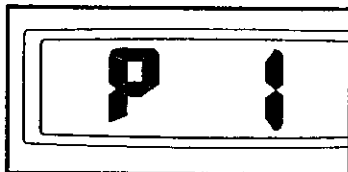

program, press the Program button repeatedly until a "P 1," "P 2," "P 3," or "P 4" appears in the display.

The four profiles on the right side of the console show how the resistance of the exercise cycle will change during the personal trainer programs. For example, profile number 3 shows that the resistance will alternately increase and decrease throughout program 3.

**3 Start the program.**

To start the program, simply begin exercising. Each personal trainer program consists of thirty, one-minute periods. One resistance setting is programmed for each period. (The same resistance setting may be programmed for consecutive periods.)

During the program, the resistance of the exercise cycle will automatically change as shown by the applicable profile on the console. If the current resistance level is too high or too low, you can change the resistance level by pressing the + and - buttons. However, when the current period of the program is completed, the resistance level will automatically change if a different resistance setting is programmed for the next period.

During the program, the display will show the time remaining in the program. If you continue exercising after the program is completed, the display will continue to show your exercise feedback.

**4 Follow your progress with the display.**

Refer to step 4 on page 10.

**5 Measure your heart rate if desired.**

See step 5 on page 10.

**6 When you are finished exercising, the console will automatically turn off after five minutes.**

Refer to step 6 on page 10.

# MAINTENANCE AND TROUBLESHOOTING

Inspect and tighten all parts of the exercise cycle regularly. Replace any worn parts immediately.

To clean the exercise cycle, use a damp cloth and a small amount of mild soap. **Important: To avoid damage to the console, keep liquids away from the console and keep the console out of direct sunlight.**

## BATTERY REPLACEMENT

If the console display becomes dim, the batteries should be replaced; most console problems are the result of low batteries. Refer to assembly step 4 on page 5 for replacement instructions. Note: The console requires four "D" batteries.

## HOW TO LEVEL THE EXERCISE CYCLE

After the exercise cycle has been moved to the location where it will be used, make sure that both ends of front stabilizer are touching the floor. If the exercise cycle rocks slightly during use, turn one or both of the leveling feet under the front stabilizer until the rocking motion is eliminated.

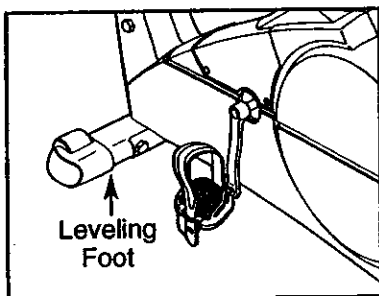

## HANDGRIP PULSE SENSOR TROUBLE-SHOOTING

- Avoid moving your hands while using the handgrip pulse sensor. Excessive movement may interfere with heart rate readings.
- Do not hold the metal contacts too tightly; doing so may interfere with heart rate readings.

- For the most accurate heart rate reading, hold the metal contacts for about 15 seconds.
- For optimal performance of the handgrip pulse sensor, keep the metal contacts clean. The contacts can be cleaned with a soft cloth—never use alcohol, abrasives, or chemicals.

## HOW TO MOVE THE EXERCISE CYCLE

To move the exercise cycle, first stand in front of the exercise cycle, hold the handlebars, and place one foot on the front stabilizer. Pull the handlebars until the exercise cycle can be moved on the front wheels. Carefully move the exercise cycle to the desired location and then lower it.

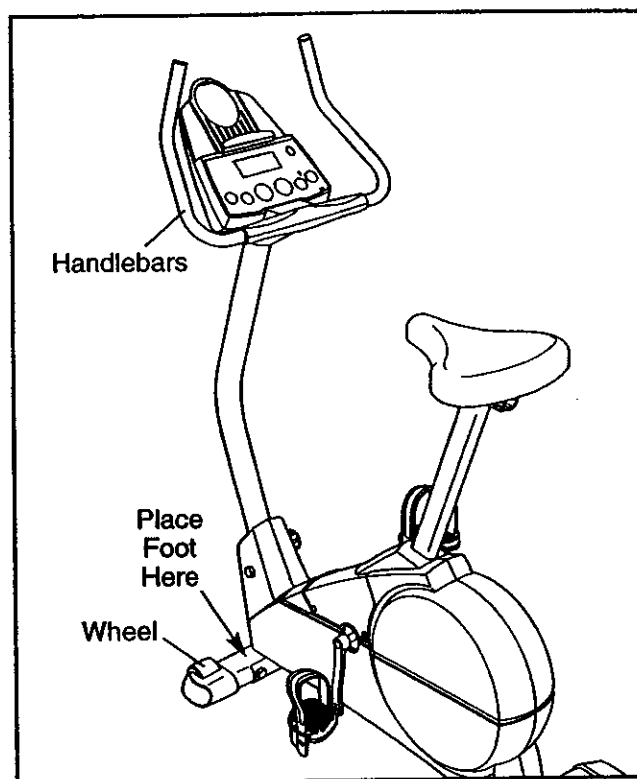

# CONDITIONING GUIDELINES

The following guidelines will help you to plan your exercise program. Remember that proper nutrition and adequate rest are essential for successful results.

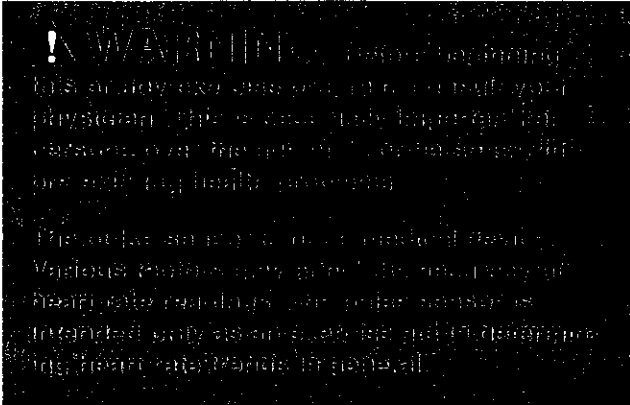

## EXERCISE INTENSITY

Whether your goal is to burn fat or to strengthen your cardiovascular system, the key to achieving the desired results is to exercise with the proper intensity. The proper intensity level can be found by using your heart rate as a guide. The chart below shows recommended heart rates for fat burning, maximum fat burning, and cardiovascular (aerobic) exercise.

165	155	145	140	130	125	115	♥
145	138	130	125	118	110	103	♥
125	120	115	110	105	95	90	♥
20	30	40	50	60	70	80	

To find the proper heart rate for you, first find your age at the bottom line of the chart (ages are rounded off to the nearest ten years). Next, find the three numbers above your age. The three numbers are your "training zone." The lowest number is the recommended heart rate for fat burning; the middle number is the recommended heart rate for maximum fat burning; the highest number is the recommended heart rate for aerobic exercise.

### Fat Burning

To burn fat effectively, you must exercise at a relatively low intensity level for a sustained period of time.

During the first few minutes of exercise, your body uses easily accessible *carbohydrate* calories for energy. Only after the first few minutes of exercise does your body begin to use stored *fat* calories for energy. If your goal is to burn fat, adjust the intensity of your exercise until your heart rate is near the lowest number in your training zone as you exercise. For maximum fat burning, adjust the intensity of your exercise until your heart rate is near the middle number in your training zone as you exercise.

### Aerobic Exercise

If your goal is to strengthen your cardiovascular system, your exercise must be "aerobic." Aerobic exercise is activity that requires large amounts of oxygen for prolonged periods of time. This increases the demand on the heart to pump blood to the muscles, and on the lungs to oxygenate the blood. For aerobic exercise, adjust the intensity of your exercise until your heart rate is near the highest number in your training zone.

## WORKOUT GUIDELINES

Each workout should include the following three parts:

**A warm-up**, consisting of 5 to 10 minutes of stretching and light exercise. A proper warm-up increases your body temperature, heart rate, and circulation in preparation for exercise.

**Training zone exercise**, consisting of 20 to 30 minutes of exercising with your heart rate in your training zone. (During the first few weeks of your exercise program, do not keep your heart rate in your training zone for longer than 20 minutes.)

**A cool-down**, with 5 to 10 minutes of stretching. This will increase the flexibility of your muscles and will help to prevent post-exercise problems.

## EXERCISE FREQUENCY

To maintain or improve your condition, plan three workouts each week, with at least one day of rest between workouts. After a few months of regular exercise, you may complete up to five workouts each week, if desired. Remember, the key to success is make exercise a regular and enjoyable part of your everyday life.

# EXPLODED DRAWING—Model No. 831.280170

R1201A

Key No.	Qty.	Description	Key No.	Qty.	Description
1	1	Frame	39	1	Flywheel Axle
2	1	Front Stabilizer	40	2	Flywheel Bearing
3	1	Rear Stabilizer	41	1	"C" Magnet
4	2	Rear Endcap	42	1	Left Crank Arm
5	1	Seat Post	43	1	Reed Switch/Wire
6	1	Seat Bracket	44	1	Crank Bearing
7	2	Handlebar Endcap	45	2	M5 Nut
8	2	Foam Grip	46	1	Adjustment Cable
9	1	Seat Adjustment Knob	47	1	Return Spring
10	6	M8 Nylon Locknut	48	1	Idler Arm
11	1	M6 x 38mm Screw	49	1	Idler Wheel w/Bearing
12	1	Seat	50	3	M10 Black Split Washer
13	1	Upright	51	3	M10 x 27mm Button Screw
14	1	Upright Bushing	52	7	M4 x 25mm Screw
15	1	Handgrip Pulse Sensor/Handlebar	53	1	"J" Bolt
16	1	Console	54	1	Pulley
17	1	Left Side Shield	55	1	M10 x 25mm Flat Bolt
18	1	Right Side Shield	56	2	Flange Screw
19	1	Side Shield Cover	57	1	Right Crank Arm
20	1	Seat Upright Bushing	58	2	M4 x 7mm Screw
21	2	M8 Push Nut	59	1	M8 x 47mm Button Bolt
22	1	Reed Switch Clamp	60	2	M6 Nut
23	2	M4 x 5mm Screw	61	2	M8 Nylon Jam Nut
24	1	Left Pedal	62	1	Flywheel Washer
25	1	Left Pedal Strap	63	5	M10 Black Nylon Locknut
26	1	Right Pedal	64	2	Idler Washer
27	1	Right Pedal Strap	65	4	M10 x 112mm Carriage Bolt
28	2	Adjustment Knob	66	11	M4 x 16mm Screw
29	2	M6 x 72mm Button Screw	67	2	Leveling Foot
30	2	Wheel	68	1	Flywheel Spacer
31	1	Left Front Endcap	69	1	M8 Flange Nut
32	1	Right Front Endcap	70	4	M8 Split Washer
33	1	M6 x 25.4mm Button Screw	71	2	M4 x 12mm Round Head Screw
34	1	Adjustment Motor	72	1	Belt
35	1	Lower Wire Harness	73	4	Motor Washer
36	1	Upper Wire Harness	#	1	User's Manual
37	1	Flywheel	#	2	Allen Wrench
38	1	Magnet			

Note: "#" indicates a non-illustrated part. Specifications are subject to change without notice. See the back cover of this manual for information about ordering replacement parts.

# EXPLODED DRAWING—Model No. 831.280170

R1201A

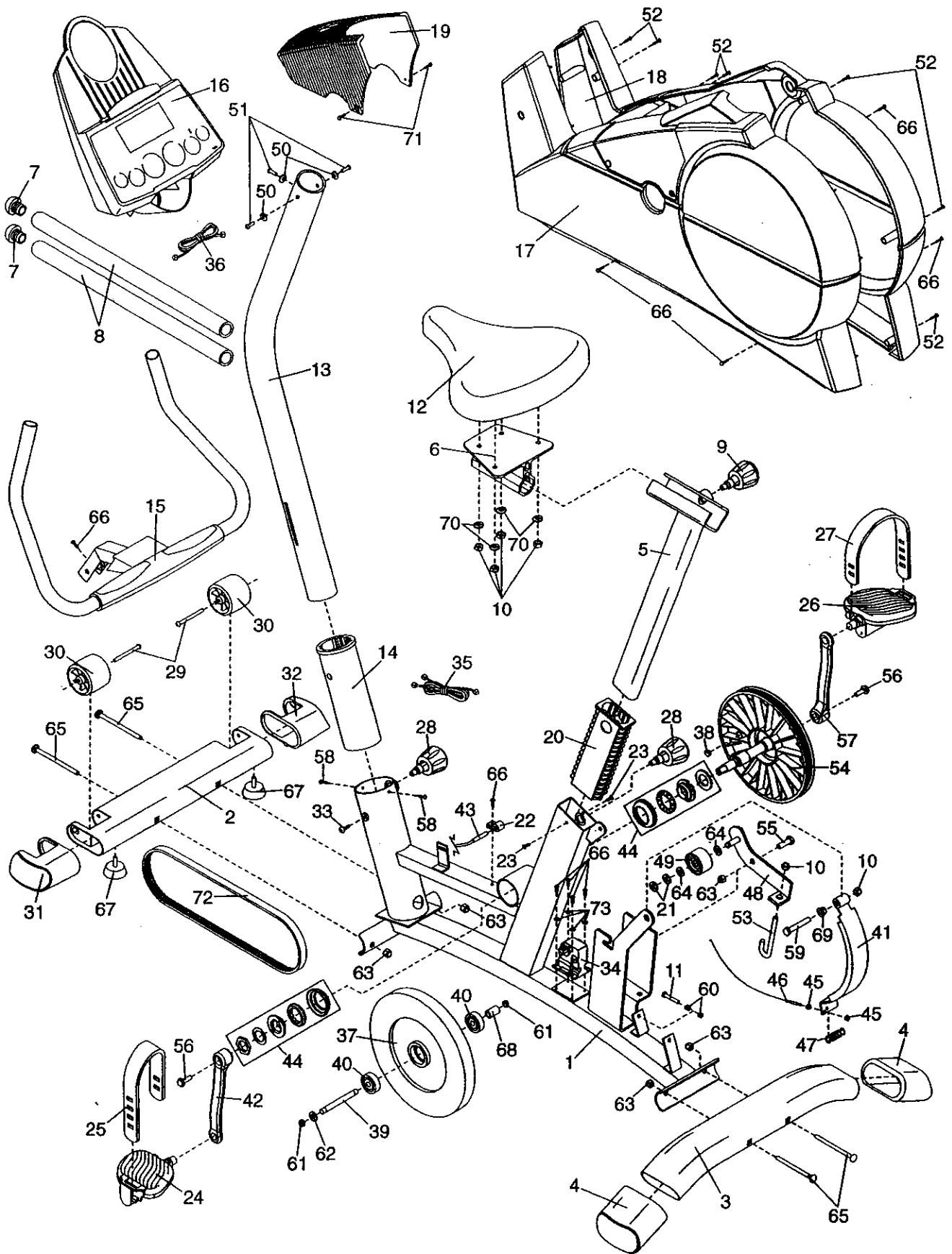

# SEARS

Model No. 831.280170

## QUESTIONS?

If you find that:

- you need help assembling or operating the PROFORM® 920 S EKG
- a part is missing
- or you need to schedule repair service

call our toll-free HELPLINE

**1-800-736-6879**

Monday–Saturday, 7 am–7 pm  
Central Time (excluding holidays)

## REPLACEMENT PARTS

If parts become worn and need to be replaced, call the following toll-free number

**1-800-FON-PART  
(1-800-366-7278)**

All replacement parts are available for immediate purchase or special order when you visit your nearest SEARS Service Center. To request service or to order parts by telephone, call the toll-free numbers listed at the left.

When requesting help or service, or ordering parts, please be prepared to provide the following information:

- The MODEL NUMBER of the product (831.280170)
- The NAME of the product (PROFORM® 920 S EKG exercise cycle)
- The KEY NUMBER and DESCRIPTION of the PART (see the PART LIST and the EXPLODED DRAWING on pages 14 and 15).

## FULL 90 DAY WARRANTY

For 90 days from the date of purchase, if failure occurs due to defect in material or workmanship in this SEARS BIKE EXERCISER, contact the nearest SEARS Service Center throughout the United States and SEARS will repair or replace the BIKE EXERCISER, free of charge.

This warranty does not apply when the BIKE EXERCISER is used commercially or for rental purposes.

This warranty gives you specific legal rights, and you may also have other rights which vary from state to state.

**SEARS, ROEBUCK AND CO., DEPT. 817WA, HOFFMAN ESTATES, IL 60179**