



Omnivision **SVHS**

Panasonic®

Video Cassette Recorder Operating Instructions

Model No. **PV-VS4821**

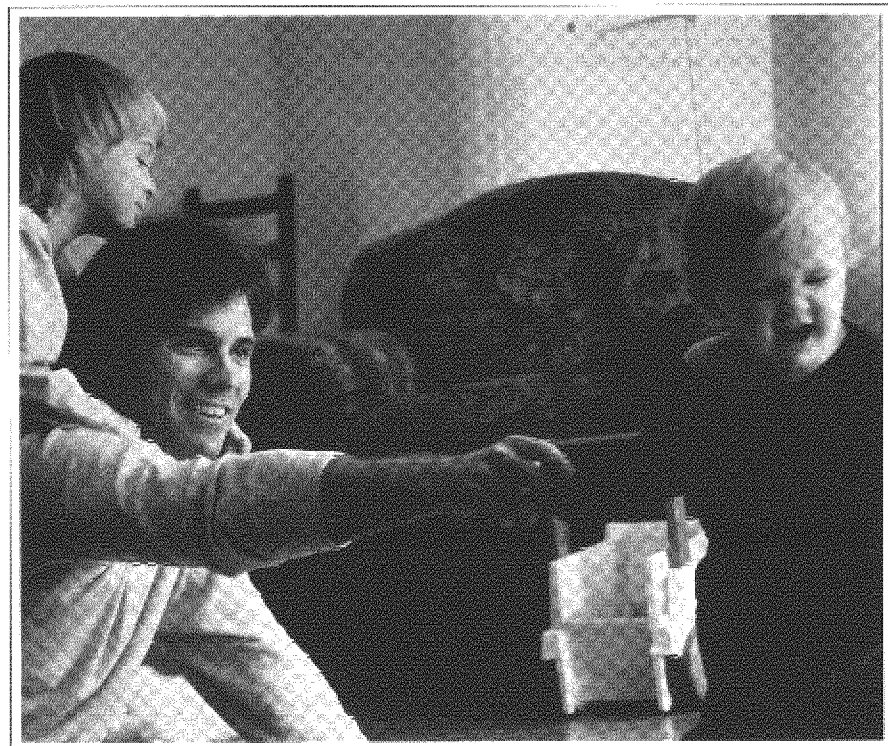

Connections and Initial Setup Procedures are on pages 8 to 15.



VCR Plus+, C², AllSet and PlusCode are registered trademarks of Gemstar Development Corporation. The VCR Plus+ system is manufactured under license from Gemstar Development Corporation.



As an ENERGY STAR® Partner, Matsushita Electric Corporation of America has determined that this product or product model meets the ENERGY STAR® guidelines for energy efficiency.

Please read these instructions carefully before attempting to connect, operate or adjust this product. Please save this manual.

Spanish Quick Use Guide is included. (Guía para rápida consulta en español está incluida.)

LSQT9370A

Initial Setup
(Connection)

Basic
Operation

Timer
Recording

Advanced
Operation

For Your
Information

Important Safeguards and Precautions

FOR YOUR SAFETY, READ AND RETAIN ALL SAFETY AND OPERATING INSTRUCTIONS. KEEP ALL WARNINGS IN THE MANUAL AND ON THE UNIT

INSTALLATION

1 POWER SOURCE CAUTION

Operate only from a power source indicated on the unit or in this manual. If necessary, have your Electric Utility Service Company or Video Products Dealer verify the power source in your home.

2 POLARIZED OR GROUNDING PLUG

As a safety feature, this Video product comes with either a polarized power cord (one blade is wider than the other), or a three-wire grounding type plug.

POLARIZED PLUG CAUTION:

This plug will only fit into an outlet one way. If you cannot fully insert the plug, try reversing it. If it still will not fit, have an electrician install the proper wall outlet. Do not defeat the safety feature by tampering with the plug.

GROUNDING PLUG CAUTION:

This plug will only fit into a three-hole grounding outlet. If necessary, have an electrician install the proper outlet. Do not defeat the safety feature by tampering with the plug.

3 POWER CORD

Make sure power cords are routed so that they are not likely to have anything rest on them, roll over them, or be in the way of walking traffic. If an extension cord is used, make sure it also has either a polarized or grounded plug and that the cords can be securely connected. Frayed cords, damaged plugs, and damaged or cracked wire insulation are hazardous and should be replaced by a qualified service technician. Overloaded outlets and extension cords are fire hazards and should be avoided.

4 DO NOT BLOCK VENTILATION HOLES

Ventilation openings in the cabinet release heat generated during operation. If they are blocked, heat build-up inside the unit can cause failures that may result in a fire hazard or heat damage to cassettes. For protection, follow these rules:

- Never cover ventilation slots or the unit while in use, or operate the unit when placed on a bed, sofa, rug, or other soft surface.
- Avoid built-in installation, such as a book case or rack, unless proper ventilation is provided.

5 AVOID EXTREMELY HOT LOCATIONS OR SUDDEN TEMPERATURE CHANGES

Do not place the unit over or near any kind of heater or radiator, in direct sunlight, inside a closed vehicle, etc.. Do not move the unit suddenly between areas of extreme temperature variation. If the unit is suddenly moved from a cold place to a warm place, moisture may condense in the unit and on the tape.

6 TO AVOID PERSONAL INJURY

- Do not place unsecured equipment on a sloping surface.
- Do not place this unit on any support that is not firm, level, and adequately strong. The unit could fall causing serious injury to a child or adult and damage to the unit.
- An appliance and cart combination should be moved with care. Quick stops, excessive force, and uneven surfaces may cause the appliance and cart combination to overturn.
- Carefully follow all operating instructions and use the manufacturer's recommended accessories when operating this unit or connecting it to any other equipment.



OUTDOOR ANTENNA INSTALLATION

1 SAFE ANTENNA AND CABLE CONNECTION

If an outside antenna or cable system is connected to the equipment, be sure the antenna or cable system is grounded so as to provide some protection against built up static charges and voltage surges. Section

810 of the National Electrical Code, ANS/NFPA 70 (in Canada, part 1 of the Canadian Electrical Code) provides information with respect to proper grounding of the mast and supporting structure, grounding of the lead-in wire

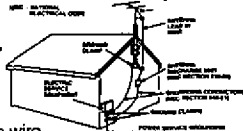

to an antenna discharge unit, size of grounding conductors, location of antenna discharge unit, connection to grounding electrodes and requirements for the grounding electrode.

2 KEEP ANTENNA CLEAR OF HIGH VOLTAGE POWER LINES OR CIRCUITS

An outside antenna system should be located well away from power lines, electric light or power circuits and where it will never come into contact with these power sources if it should happen to fall. When installing an outside antenna, extreme care should be taken to avoid touching power lines, circuits or other power sources as this could be fatal. Because of the hazards involved, antenna installation should be left to a professional.

USING THE VIDEO UNIT

If the unit has been in storage or moved to a new location, refer first to the INSTALLATION section of these safeguards.

1 KEEP THIS VIDEO UNIT AWAY FROM WATER OR MOISTURE OF ANY KIND.

2 IF EQUIPMENT IS EXPOSED TO RAIN, MOISTURE, OR STRONG IMPACT, unplug the unit and have it inspected by a qualified service technician before use.

3 DURING AN ELECTRICAL STORM

During a lightning storm, whether indoors or outdoors, or before leaving the unit unused for extended periods of time, disconnect all equipment from the power source as well as the antenna and cable system.

4 WHEN THE UNIT IS PLUGGED IN

- Never expose the unit to rain or water. DO NOT OPERATE if liquid has been spilled into the unit. Immediately unplug the unit, and have it inspected by a service technician. Fire and shock hazards can result from electrical shorts caused by liquid contact inside.
- Never drop or push any object through openings in the unit. Some internal parts carry hazardous voltages and contact can cause electric shock or fire hazard.
- Avoid placing the unit directly above or below your TV set as this may cause electrical interference. Keep all magnets away from electronic equipment.

5 USING ACCESSORIES

Use only accessories recommended by the manufacturer to avoid risk of fire, shock, or other hazards.

6 CLEANING THE UNIT

Unplug the unit. Then, use a clean, dry, chemically untreated cloth to gently remove dust or debris. DO NOT USE cleaning fluids, aerosols, or forced air that could over-spray, or seep into the unit and cause electrical shock. Any substance such as wax, adhesive tape, etc. may mar the cabinet surface. Exposure to greasy, humid, or dusty areas may adversely affect internal parts.

SERVICE

1 DO NOT SERVICE THIS PRODUCT YOURSELF

If, after carefully following the detailed operating instructions, this Video product does not operate properly, do not attempt to open or remove covers, or make any adjustments not described in the manual. Unplug the unit and contact a qualified service technician.

2 IF REPLACEMENT PARTS ARE REQUIRED

Make sure the service technician uses only parts specified by the manufacturer, or those having the same safety characteristics as the original parts. The use of unauthorized substitutes may result in fire, electric shock, or other hazards.

3 HAVE THE SERVICE TECHNICIAN PERFORM A SAFETY CHECK

After any service or repairs to the unit, request the service technician to conduct a thorough safety check as described in the manufacturer's service literature to ensure that the video unit is in safe operating condition.

Safety Precautions/Mesures de sécurité

WARNING: To prevent fire or shock hazard, do not expose this equipment to rain or moisture.

CAUTION: To prevent electric shock, match wide blade of plug to wide slot, fully insert.

Avertissement: Afin de prévenir tout risque d'incendie ou de chocs électriques, ne pas exposer cet appareil à la pluie ou à une humidité excessive.

Attention: Pour éviter les chocs électriques, introduire la lame la plus large de la fiche dans la borne correspondante de la prise et pousser jusqu'au fond.

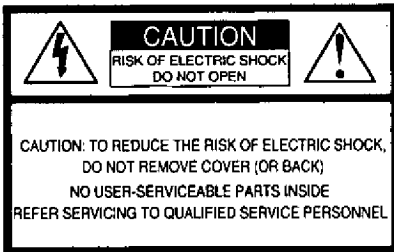

This symbol warns the user that uninsulated voltage within the unit may have sufficient magnitude to cause electric shock. Therefore, it is dangerous to make any kind of contact with any inside part of this unit.



This symbol alerts the user that important literature concerning the operation and maintenance of this unit has been included. Therefore, it should be read carefully in order to avoid any problems.

Note to CABLE system installer:

This reminder is provided to call the CABLE system installer's attention to Article 820-40 of the NEC in USA (and to the Canadian Electrical Code in Canada) that provides guidelines for proper grounding and, in particular, specifies that the cable ground shall be connected to the grounding system of the building, as close to the point of cable entry as practical.

FCC Warning: Any unauthorized changes or modifications to this equipment would void the user's authority to operate.

Congratulations

on your purchase of one of the most sophisticated and reliable products on the market today. Used properly, it will bring you years of enjoyment. Please fill in the information below. The serial number is on the tag located on the back of your VCR.

- Date of Purchase _____
- Dealer Purchased From _____
- Dealer Address _____
- Dealer Phone No. _____
- Model No. **PV-VS4821** _____
- Serial No. _____

Accessories

- Remote Control LSSQ0299
- Batteries 2 "AA"

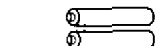
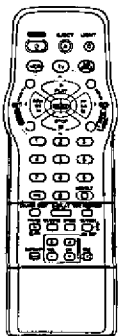

- RF Coaxial Cable VJAS0196



- S-VHS Connecting Cable VJAS0200



To order accessories, call toll free 1-800-332-5368.

Loading the Batteries

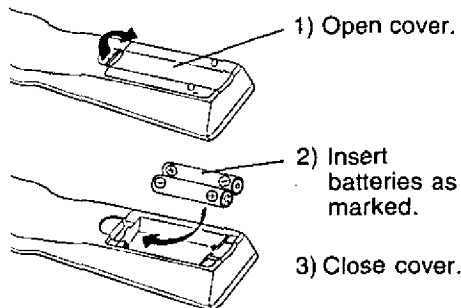

- Battery replacement caution**
- Do not mix old and new batteries.
- Do not mix alkaline with manganese batteries.

Prevent Accidental Tape Erasure

Break off the tab to prevent recording.

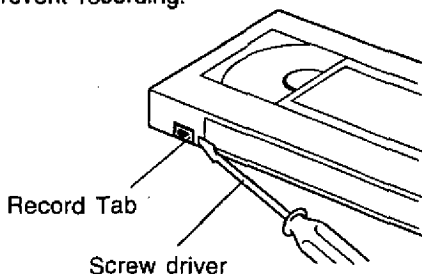

To record again



Record/ Playback Time

Only use tapes with the **VHS** or **SVHS** mark in this unit.

Tape Speed Setting	Type of Video Cassette		
	T60	T120	T160
SP (Standard Play)	1 Hour	2 Hours	2 Hours 40 Minutes
LP (Long Play)	2 Hours	4 Hours	5 Hours 20 Minutes
SLP (SuperLongPlay)	3 Hours	6 Hours	8 Hours

- LP recording is not possible in S-VHS/ S-VHS ET mode.

Important Safeguards and Precautions	2, 3
Accessories	4
Loading the Batteries	4
Prevent Accidental Tape Erasure	4
Record/ Playback Time	4
Location of Controls	6, 7
Initial Setup for DSS/ Cable Box Channel Control	8, 9
Initial Setup for ANT/ Cable-VCR-TV Connection	10, 11
Initial Setup for DSS/ Cable Box-VCR-TV Connection	12 ~ 15
<hr/>	
Reset Language, Channels, Clock, VCR's Output Channel	16, 17
Playback a Tape	18
Record on a Tape	19
<hr/>	
Timer Recording	20, 21
Timer Recording Using VCR Plus+® System	22 ~ 25
<hr/>	
Multi-Brand Control Feature	26, 27
Advanced Connections	28
MTS Broadcast/ VHS Hi-Fi Stereo System	29
Tape Operation (<i>COMMERCIAL**ADVANCE*</i> , <i>MOVIE**ADVANCE*</i>)	30 ~ 35
Special VCR Features	36 ~ 41
Super (S) VHS System	42, 43
Copying Your Tapes (Dubbing)	44
<hr/>	
VCR & Cassette Information	45, 46
On-Screen Displays (OSD)	47, 48
Before Requesting Service	49
Service Center List	50
Limited Warranty	51
Spanish (Español) Quick Use Guide	52 ~ 55
Index	Back Cover

Initial Setup
(Connection)

Basic
Operation

Timer
Recording

Advanced
Operation

For Your
Information

Remote control Buttons

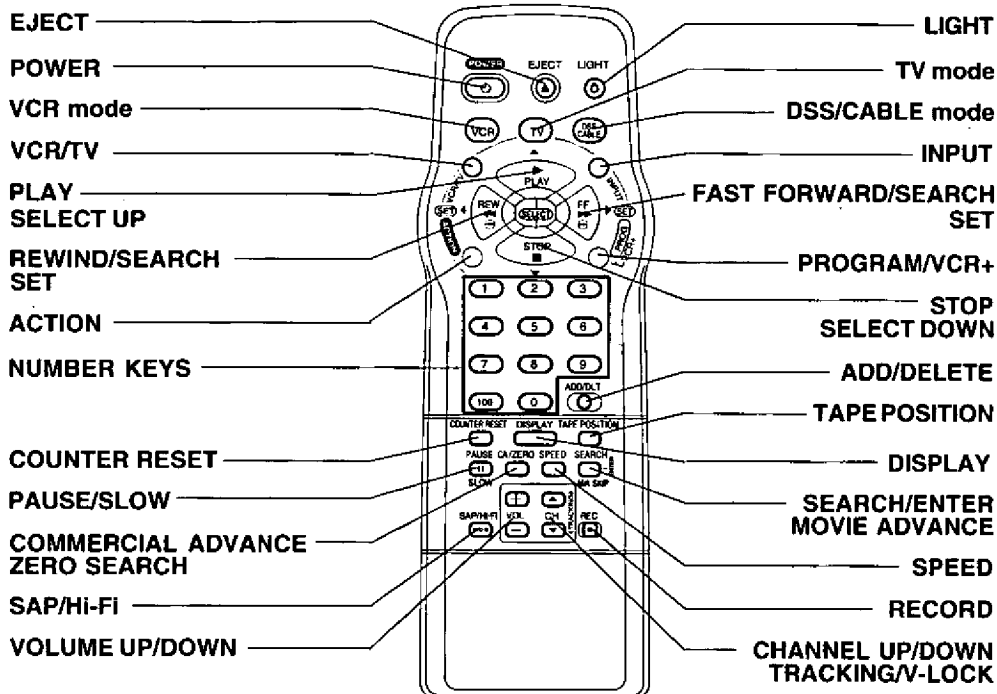

Light Tower Universal Remote Control

Light button: When LIGHT is pressed, available buttons in the selected mode light up and the selected mode button (TV, VCR or DSS/CABLE) flashes for 5 seconds. If no button is pressed, light goes out in 5 seconds to conserve batteries. Also, by holding down a button, you can confirm the selected mode (mode button will flash) in the dark.

EJECT button: Press to eject tape from VCR. If EJECT is pressed during record, VCR will not respond.

Front View of the VCR

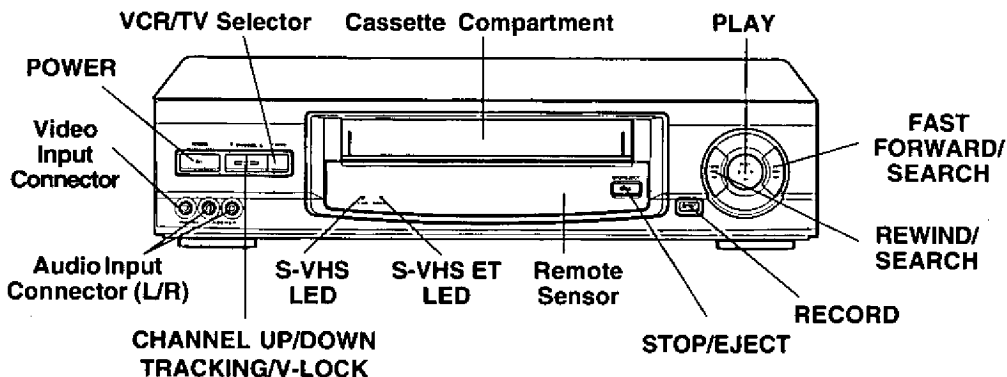

Multi Function Display

Power Indicator

Lights up when power is on.

Timer Indicator

Lights up when the VCR is set for Timer Recording, or when One Touch Recording (OTR) is used. Flashes when Timer Recording is set, but a tape has not been inserted into the VCR and when a power interruption occurs during Timer Programming.

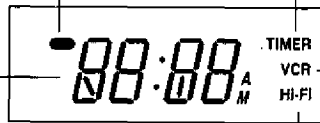

VCR Indicator

Lights up when the VCR/TV selector is set to VCR.

Hi-Fi Indicator

Lights up when Hi-Fi audio is monitored in Playback Mode.

Clock/ Status/ Channel/ Speed Display

Displays the current time. Briefly displays VCR status when a function button is pressed. Briefly displays the channel number, or "L1" or "L2" when a channel or line input is selected. Briefly displays the recording speed when SPEED is pressed.

Rear View of the VCR

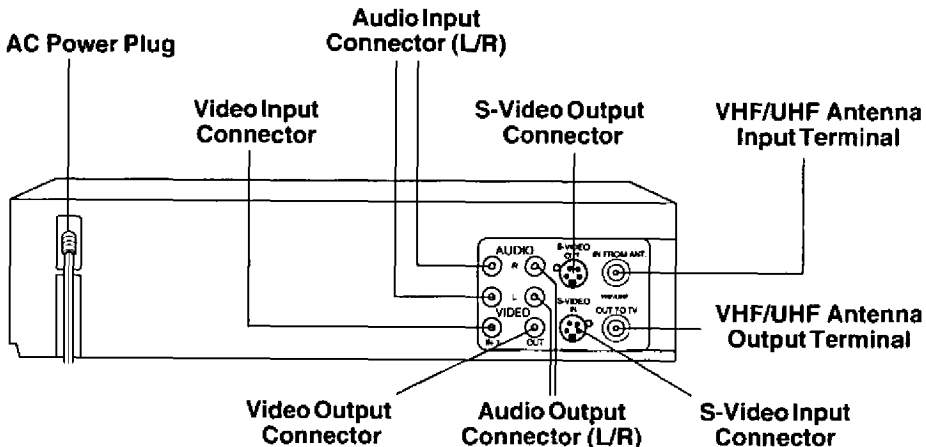

Note

- While plugged into an AC outlet, the VCR consumes 3.7 W of electrical power in off mode.

The setup on pages 10 through 15 is vital for proper VCR operation. Please read the instructions carefully and in the order presented.

NOTE: These first two pages contain reference material needed for setup on pages 10 ~ 15. Please look over the information before you begin setup procedure.

Setup Overview

You will be performing the following tasks:

- Setting the language you want on-screen displays to appear in (English, Spanish, French).
- Telling the VCR the kind of equipment you use to receive channels and how it is connected.
- Entering pertinent Cable Box or DSS Receiver information if used.
- Entering your local PBS (Public Broadcasting Station) channel so that the VCR can receive auto clock set data. (Not available in all areas.)
- Placing channels in memory and setting the clock.

Please Note Which Connection Type You are Using.

Make sure all equipment is hooked up as described on pages 10 ~ 15.

The diagrams below illustrate some of the basic connection types.

Confirm which type you used for later reference.

Connection Type A

(Go to "Initial Setup" on page 10.)

<VCR → TV connection>

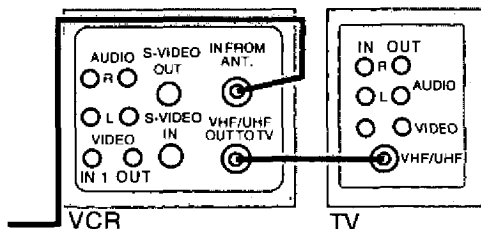

Connection Type B

(Go to "Initial Setup" on page 12.)

<Cable Box → VCR → TV connection>

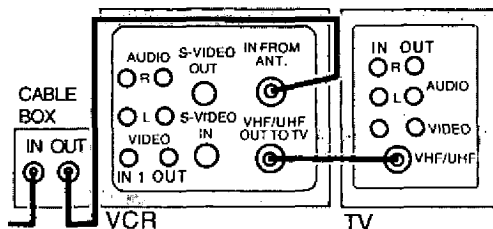

<DSS Receiver → VCR → TV connection>

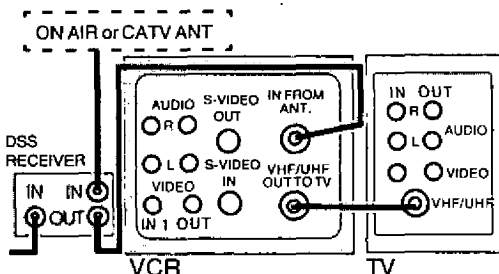

INITIAL SETUP IMPORTANT NOTES:

- For detailed DSS Receiver connection instruction, please see your DSS operating manual.
- A DSS Receiver must be turned off to view programs from the Cable Box or antenna.
- Also, the a DSS Receiver must be turned off for auto clock set.
- If your Cable Box is not remote controllable, it must be tuned to your PBS channel.
- If you use Audio/ Video Jack connection between the VCR and Cable Box or DSS Receiver, you must also connect the RF coaxial cable in order to use auto clock set and channel auto set features.

Cable Box/ DSS Receiver Code Number List

If your Cable Box or DSS Receiver is remote controllable, refer to this list during setup on page 13.

Cable Box

Brand	Code Number	Brand	Code Number
Archer	44, 06, 01	RCA	17, 16, 08
Cableview	29, 09, 01, 63	Realistic	44, 51, 75, 59
Citizen	44, 52, 30	Recoton	44, 51, 75, 59
Curtis	08, 09, 25, 61, 53	Regal	41, 14, 15, 28
Century	44, 51, 75, 59	Regency	28, 29
Cabletenna	29, 09, 01, 63	Rembrandt	44, 42, 63, 29
CableCinema	29, 09, 01, 63	Samsung	42, 06, 32
Diamond	29, 09, 01, 63	Scientific Atlanta	08, 09, 25, 61, 53
Eagle	62, 40, 22, 13, 58, 20	Sheritech	27
Eastern	28, 29	Signal	26
Explorer	08, 09, 25, 61, 53	SL Marx	42, 06, 32
Gemini	30, 04	Sprucer	17, 16, 08
General Electric	01, 57	Standard Components	32, 39
General Instruments	01, 84, 83, 34, 03, 02, 04, 55, 65, 66, 67, 68	Stargate	04, 42
Gerrard	44, 51, 75, 59	Sylvania	19, 18
GC Electronics	44, 42, 63, 29	Teknika	74, 35
Hamlin	41, 14, 15, 28	Telecaption	77
Hitachi	31	Televue	40, 19, 38, 32
Jerrold	01, 84, 83, 34, 03, 02, 04, 55, 65, 66, 67, 68	Texscan	19, 18
Jasco	30, 04	Tocom	34, 33, 01, 42, 66
Macom	31	Toshiba	36
Magnavox	26	Unika	44, 42, 63, 29
Matsushita	17, 16, 08	Universal	52, 43, 44, 63
Movietime	32, 39	Viewstar	62, 40, 22, 13, 58, 20
Maestro	74, 35	Videoway	07, 23, 50
NEC	40, 19, 38, 32	Vidtek	64
NSC	40, 19, 38, 32	Zenith	07, 23, 50
Novavision	08, 09, 25, 61, 53		
Next Level	01, 84, 83, 34, 03, 02, 04, 55, 65, 66, 67, 68		
Oak	46, 11		
Oak Sigma	46, 11		
Panasonic	17, 16, 08		
Philips	23, 24, 20, 13		
Pioneer	06, 05, 12		
Pulsar	04, 42		
Quest	06, 05, 12		
Radio Shack	44, 51, 75, 59		

DSS (Digital Satellite System) Receiver

Toshiba	90
Hitachi/ Hughes	91, 99
Primestar	92
Drake	93
Magnavox	94, 95
Uniden	94, 95
Optimus	94, 95
Panasonic	96
ProScan	97
RCA	97
SONY	98, 105

Note

- Some brands list several codes, so you may need to try different codes to attain proper results. These codes are used for Cable Box or DSS Receiver setup for Auto Clock and VCR Plus+ recording only. For TV/ Cable Box Multi-Brand Control operation, please see page 26.

Positioning Your Cable Box or DSS Receiver

If your Cable Box or DSS Receiver is remote controllable, place it on or near the VCR as shown in the example at right. The VCR transmits an infrared signal from two locations. Be sure not to cover the transmitter windows.

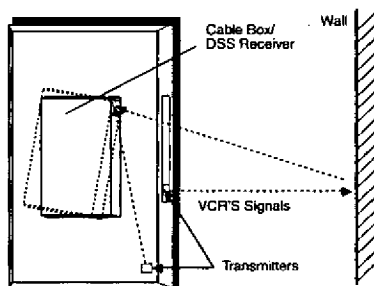

Initial Setup
(Connection)

How to Connect

For Connection Type A [VCR-TV].

- 1 Connect the Cable from Antenna/Cable to the IN FROM ANT. terminal on VCR.
- 2 Connect the OUT TO TV terminal on the rear of VCR to the ANT. IN terminal on your TV using the RF Cable (included accessory).

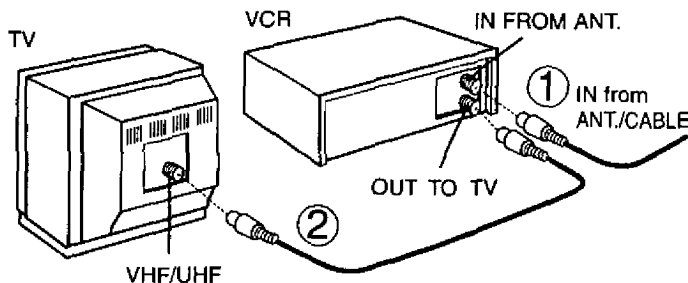

How to do Initial Setup

1 Press **VCR** button* on the remote for VCR mode. Turn your TV on and set it to channel 3.

2 Press **POWER** to turn VCR on.

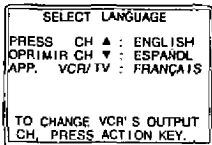
3  Press **CH ▲** for English.
OR
Press **CH ▼** for Spanish.
OR
Press **VCR/TV** for French.
to select language.

- When VCR is turned on for the first time, SELECT LANGUAGE screen appears.
- If wrong language is set, or there is not Language Display, do "Reset All VCR Memory Functions" steps on page 11.
- If screen does not appear, check connection between VCR and TV and, if TV is tuned to channel 3, try switching it to channel 4.
- When you want to change the output channel of VCR, please refer to VCR's Output Channel on page 17.

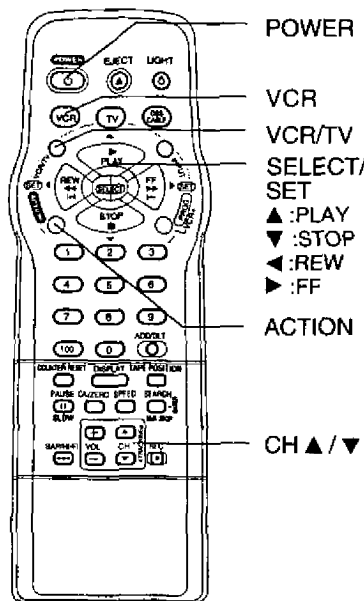

WARNING

When using "Nut type" RF coaxial cables, tighten with fingers only. Overtightening may damage terminals.

4

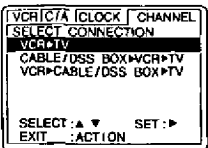

Press ▲▼ (see right) to select "VCR ► TV" connection and press ► to set.

Using ▲▼◀▶ keys

You can operate the menu screen using Remote buttons. When menu screens are displayed, the PLAY, STOP, REWIND, and FF buttons on the remote function as ▲▼◀▶.

▲: PLAY
▼: STOP
◀: REW
▶: FF

5

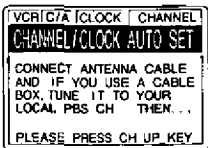

Press CH ▲ to start Channel/Clock Auto Set operation.

For "CABLE/DSS BOX ► VCR ► TV" connection only.

- Turn on your Cable Box and set it to your Public Broadcasting Station (PBS) channel in your time zone.
- If you use a DSS Receiver, it must be turned off.

6

Settings are performed automatically.

Case 1 Setup complete...

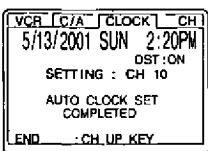

Press CH ▲ to exit.

Case 2 Setup incomplete...

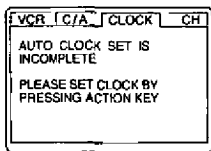

Press ACTION to display Manual Clock Set screen.

Reset All VCR Memory Functions

Use when moving VCR to new location, or if a mistake was made in the Initial Setup section.

- Make sure a tape is not inserted in the VCR.



- 1 Turn VCR Power on.
- 2 Press and hold both **PLAY** and **CHANNEL ▲** on the VCR for more than 5 seconds.
 - The power shuts off.
- 3 Do "Initial Setup" on page 10.

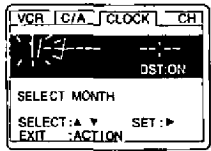

Press ▲▼ to select the month and press ► to set.

- In the same manner, select and set the date, year, time, and DST (daylight saving time).

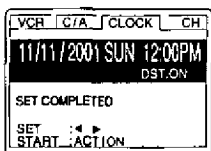

Press ACTION twice to start CLOCK and exit.

How to Connect

For Connection Type B [DSS/ Cable Box-VCR-TV].

- 1 Connect the OUT Jack on your Cable Box to the IN FROM ANT. terminal on the VCR with the RF Cable.
- 2 Connect the OUT TO TV terminal on the rear of VCR to the ANT. IN terminal on your TV using the RF Cable (included accessory).

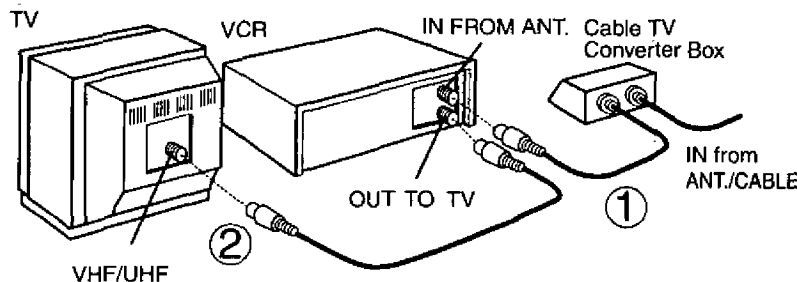

How to do Initial Setup

1 Press **VCR** button* on the remote for VCR mode. Turn your TV on and set it to channel 3.

2 Press **POWER** to turn VCR on.

3 **Press CH ▲** for English.
 OR
Press CH ▼ for Spanish.
 OR
Press VCR/TV for French.
 to select language.

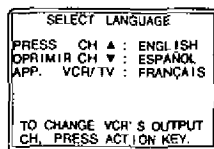

- When VCR is turned on for the first time, **SELECT LANGUAGE** screen appears.
- If wrong language is set, or there is not Language Display, do "Reset All VCR Memory Functions" steps on page 11.
- If screen does not appear, check connection between VCR and TV and, if TV is tuned to channel 3, try switching it to channel 4.
- When you want to change the output channel of VCR, please refer to VCR's Output Channel on page 17.

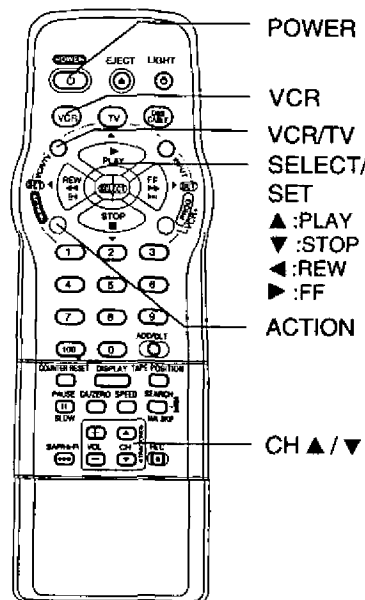

WARNING

When using "Nut type" RF coaxial cables, tighten with fingers only. Overtightening may damage terminals.

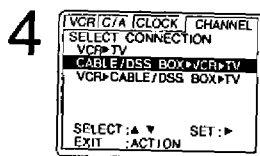

Press ▲▼ (see right) to select "CABLE/DSS BOX▶VCR▶TV" connection and press ▶ to set.

- Confirm the output channel of your Cable Box or DSS Receiver.

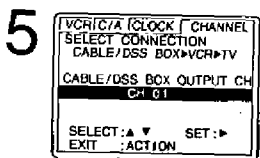

Press ▲▼ to select the same channel as the Cable Box or DSS Receiver output channel. Press ▶ to enter.

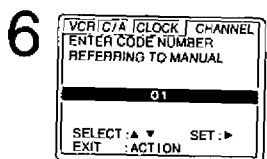

Press ▲▼ to select Cable Box or DSS Receiver code. (Refer to list, page 9.) Press ▶ to set.

- If Cable Box or DSS Receiver has no remote control, press ▼ to select "NO REMOTE" and press ▶ to set. Then, go to step 5 "CHANNEL/CLOCK AUTO SET" on page 11.
- This determines whether VCR will control Cable Box or DSS Receiver.

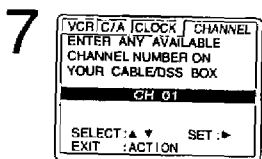

Press ▲▼ to select any channel your Cable Box or DSS Receiver receives. Press ▶ to set.

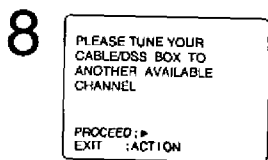

Tune Cable Box or DSS Receiver channel. Press ▶ to continue.

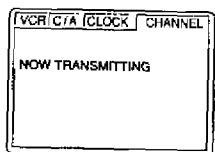

"NOW TRANSMITTING" appears.

Using ▲▼◀▶ keys

You can operate the menu screen using Remote buttons. When menu screens are displayed, the PLAY, STOP, REWIND, and FF buttons on the remote function as ▲▼◀▶.

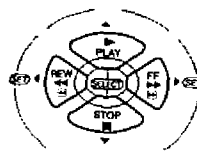

▲: PLAY
▼: STOP
◀: REW
▶: FF

Initial Setup
(Connection)

Continued on next page...

9

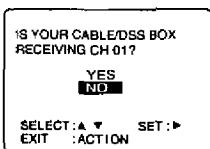

Press ▲▼ to select "YES" or "NO."
Press ► to set.

- If "YES" (with Cable Box), go to step 10.
- If "YES" (with DSS Receiver), go to **step 5** "CHANNEL/CLOCK AUTO SET" on page 11.
- If "NO," the screen in step 6 will appear. Try entering a different code and/ or repositioning the equipment (see page 9.)
- If still "NO," Cable Box or DSS Receiver is not available. Press ACTION. Then, go to **step 5** "CHANNEL/CLOCK AUTO SET" on page 11.

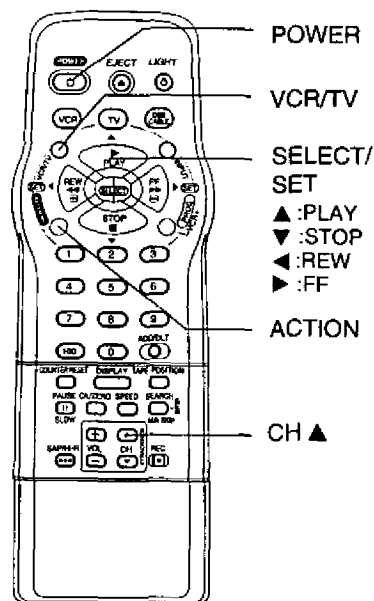

10

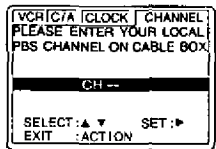

Press ▲▼ to select channel on which Cable Box receives your local Public Broadcasting Station(PBS).
Press ► to set.

11

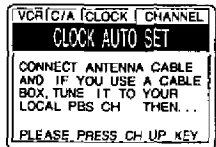

Press CH ▲ to start Clock Auto Set.

- "AUTO CLOCK SET PROCEEDING" appears.

12

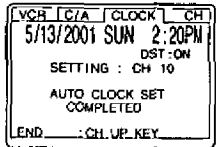

Confirm that time is correct.
Press CH ▲ to exit.

14

If displayed time is incorrect...

If your area observes DST (daylight saving time), but the time is incorrect; do "Time Zone Adjust" steps on page 17.

Or, if you use Cable Box and receive more than one PBS station, try auto clock set again entering the one you have not tried yet. (Go to "Clock" on page 16.)

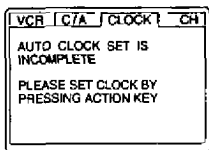

If appears "AUTO CLOCK SET IS INCOMPLETE" on-screen...

Auto clock set data is not available in your area. Press ACTION to display Manual Clock Set screen, and then go to step 6 (case 2) on page 11.

To setup VCR in case a Cable Box or DSS Receiver was installed or replaced.

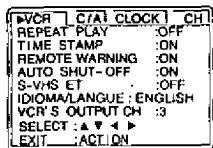

- a Press ACTION to display MENU.
- b Press ◀▶ to select CHANNEL.
- c Press ▲▼ to select "CABLE/ DSS BOX SET UP", then press ▶.
- d Press ▲▼ to select "CABLE/ DSS BOX ▶ VCR ▶ TV", then press ▶ to set.
- e Continue with steps 5 ~ 9 on pages 13, 14.

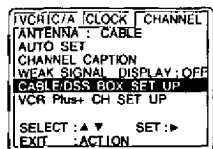

Note

- Auto clock set will be performed when VCR is turned off the first time each day. Therefore, Cable Box must be left on.

1

VCR	C/A	CLOCK	CH
REPEAT PLAY	:OFF		
TIME STAMP	:ON		
REMOTE WARNING	:ON		
AUTO SHUT-OFF	:ON		
S-VHS ET	:OFF		
IDIOMA/LANGUE	: ENGLISH		
VCR'S OUTPUT CH	: 3		
SELECT	:▲▼◀▶	SET:	▶
EXIT	:ACTION		

Press **ACTION***
to display MENU.

2

Language

- 1) Press ▲▼ to select language item.

VCR	C/A	CLOCK	CH
REPEAT PLAY	:OFF		
TIME STAMP	:ON		
REMOTE WARNING	:ON		
AUTO SHUT-OFF	:ON		
S-VHS ET	:OFF		
IDIOMA/LANGUE	: ENGLISH		
VCR'S OUTPUT CH	: 3		
SELECT	:▲▼	SET:	▶
EXIT	:ACTION		

- 2) Press ► repeatedly.

VCR	C/A	RELOJ	CA
REPETICION	:INACT		
SELLO DE TIEMPO	:ACT		
AVISO(CONT.REMOTO)	:ACT		
APAGADO AUTOMATICO	:ACT		
S-VHS ET	:INACT		
LANGUE/LANGUAGE	:ESPANOL		
CANAL DE SALIDA	: 3		
ELEGIR	:▲▼	FLJAR:	▶
SALIR	:ACTION		

For Spanish

MAGNETO	C/A	HORL	CA
REPRISE LECTURE	:NON		
HORODATEUR	:OUI		
MESSAGE D'ERREUR	:OUI		
COUURE AUTO	:OUI		
S-VHS ET	:NON		
LANGUE/IDIOMA	: FRANCAIS		
CA SORTIE	: 3		
SEL	:▲▼	REGLER:	▶
QUITTER	:ACTION		

For French

VCR	C/A	CLOCK	CH
REPEAT PLAY	:OFF		
TIME STAMP	:ON		
REMOTE WARNING	:ON		
AUTO SHUT-OFF	:ON		
S-VHS ET	:OFF		
IDIOMA/LANGUE	: ENGLISH		
VCR'S OUTPUT CH	: 3		
SELECT	:▲▼	SET:	▶
EXIT	:ACTION		

For English

- 3) Press ACTION to exit.

Channels

- 1) Press ◀▶ to select CHANNEL.

VCR/C/A	CLOCK	CHANNEL
ANTENNA	: CABLE	
AUTO SET		
CHANNEL CAPTION		
WEAK SIGNAL DISPLAY	:OFF	
CABLE/DSS BOX SET UP		
VCR Plus+ CH SET UP		
SELECT	:▲▼	▶
EXIT	:ACTION	

- 2) Press ▲▼ to select "ANTENNA," then press ► to set your antenna system (TV or CABLE).

VCR/C/A	CLOCK	CHANNEL	
ANTENNA	: CABLE		
AUTO SET			
CHANNEL CAPTION			
WEAK SIGNAL DISPLAY	:OFF		
CABLE/DSS BOX SET UP			
VCR Plus+ CH SET UP			
SELECT	:▲▼	SET:	▶
EXIT	:ACTION		

- 3) Press ▲▼ to select "AUTO SET," then press ►.

VCR/C/A	CLOCK	CHANNEL
CHANNEL/CLOCK	AUTO SET	
CONNECT ANTENNA CABLE		
AND IF YOU USE A CABLE		
BOX, TUNE IT TO YOUR		
LOCAL PBS CH THEN...		
PLEASE PRESS CH UP KEY		

(This screen appears only when auto clock is set.)

- 4) Press CH ▲.

• After Channel Auto Set is finished, Clock Auto Set will be performed.

Clock

- 1) Press ◀▶ to select CLOCK.

VCR	C/A	CLOCK	CH
AUTO CLOCK SET			
MANUAL			
TIME ZONE ADJUST	: 0		
SELECT	:▲▼	▶	
EXIT	:ACTION		

- 2) Press ▲▼ to select MANUAL and press ►. (For Auto Clock Set, select "AUTO CLOCK SET," then press CH ▲.)

VCR	C/A	CLOCK	CH
AUTO CLOCK SET			
MANUAL			
TIME ZONE ADJUST	: 0		
SELECT	:▲▼	SET:	▶
EXIT	:ACTION		

("TIME ZONE ADJUST" appears only when auto clock is set.)

VCR	C/A	CLOCK	CH
11/11/2001	SUN	12:00PM	DST:ON
SELECT HOUR			
SELECT	:▲▼	SET:	▶
EXIT	:ACTION		

- 3) Press ▲▼ and ◀▶ to select and set the date, time, and DST (Daylight Saving Time).

- 4) Press ACTION twice to start the clock and exit this mode.

***Important:** If a remote control button does not work when pressed, press the VCR button on the remote and try the button again.

Time Zone Adjust

(Only when Auto Clock is set.)

- 1) Press ◀▶ to select **CLOCK**.

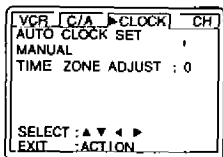

- 2) Press ▲▼ to select **TIME ZONE ADJUST**

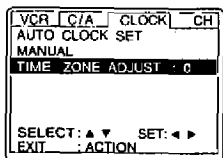

and press ◀ or ▶ to subtract or add hour(s) as necessary.

- 3) Press **ACTION**.

- 4) Press **POWER** off and wait a maximum 10 minutes until **AUTO CLOCK SET** is performed by the VCR.

- **TIME ZONE ADJUST** returns to "0" if clock is set manually.

VCR's Output Channel

- 1) Press ▲▼ to select **VCR'S OUTPUT CH.**

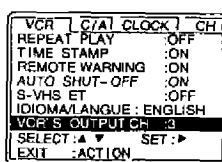

- 2) Press ▶.

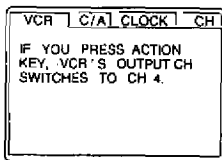

- 3) Press **ACTION**.

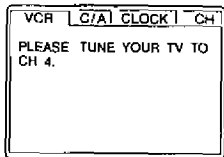

After 3 seconds

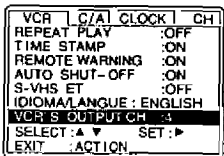

- To Make Corrections, repeat steps 1) - 3).

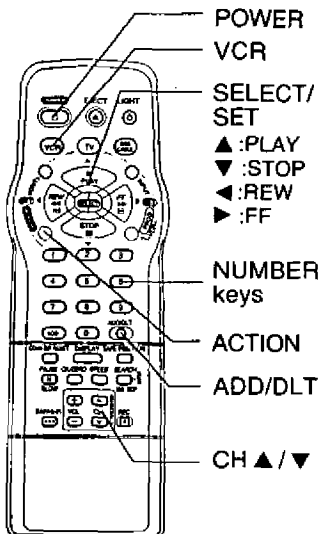

Add or Delete a Channel

To add channel:
Select channel with number keys and press **ADD/HLT**.

CHANNEL 08 ADDED

To delete channel:
Select channel with **CH ▲ / ▼** or number keys and press **ADD/HLT**.

CHANNEL 08 DELETED

DST (Daylight Saving Time)

VCR auto adjusts clock for DST. (Page 11.)

Spring (First Sunday In April)

DST:ON --> Sets clock ahead one hour.

Autumn (Last Sunday In October)

DST:ON --> Turns clock back one hour.

- If your area does not observe Daylight Saving Time, select **DST:OFF**.
- Keep these time changes in mind when programming the VCR for timer recordings.

Playback a Tape

Note

Remove loose or peeling labels from tapes to prevent tape jam.

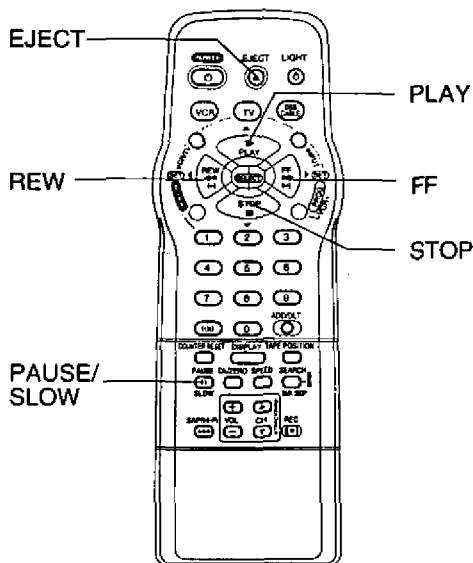
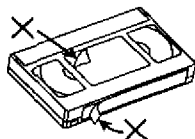

Ready Check List

- All connections are made (pg. 10, 12, 28).
- TV and VCR are plugged in.
- TV is on and tuned to CH3, 4, or VIDEO.
- Remote is in VCR mode. (Press VCR.)

1 Insert a tape.

- VCR power comes on.
- "VCR" lights up on Multi Function Display.

2 Press PLAY* to play a tape.

- If tape has no rec. tab (pg. 4), auto play begins.

Special Features During Play

- **Forward/ Reverse scene search**
--> Press FF or REW.
--> Press again or PLAY to release.
- **Still (Freeze) picture**
--> Press PAUSE/SLOW.
--> Press PLAY to release.
- **Frame by Frame picture**
--> Press PAUSE/SLOW in Still mode.
--> Press PLAY to release.
- **Slow Motion picture**
--> Hold down PAUSE/SLOW in Still mode.
--> Press PLAY to release.

Notes

- These features work best in SP or SLP mode.
- The sound will be muted.
- To reduce picture noise, see "Manual Tracking Control" on page 46.
- After the VCR is in Still or Slow mode for 3 minutes, it will switch to Stop mode automatically to protect the tape and the video head.

Playback using VCR controls

1 Insert a tape.

2 Press PLAY.



Multi Function Display

- Press STOP/EJECT to stop and/ or eject tape.

3 Press STOP to stop a tape.

Rapid Rewind/FF

- **Press REW or FF in Stop mode** to rewind/ fast forward a tape.
 - Rewind tapes in approximately one minute when using a T-120 tape.
- **Press EJECT on the remote,** or **STOP/EJECT on VCR** to eject a tape.

Record on a Tape

Important: If a remote control button does not work when pressed, press the VCR button on the remote and try the button again.

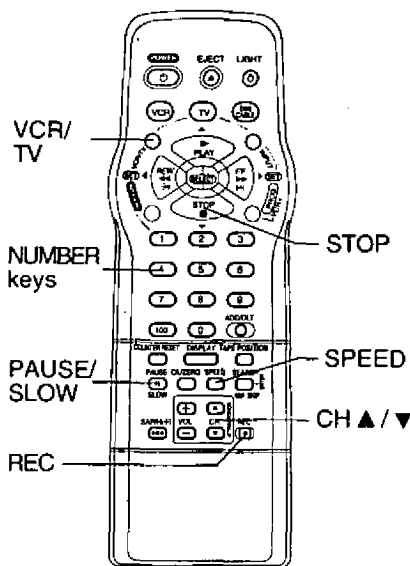

✓ Ready Check List

- All connections are made (pg. 10, 12, 28).
- TV and VCR are plugged in.
- TV is on and tuned to CH3, 4, or VIDEO.
- Remote is in VCR mode. (Press VCR)

1 Insert a tape with a record tab (pg. 4).

- VCR power comes on.
- "VCR" lights up on Multi Function Display.

2 Press CH ▲▼, or number keys to select the channel.

- For "LINE" input, see pg. 44.
- For channels over 100, press 100 key then press the remaining 2 digits.

3 Press SPEED to select the record speed (pg. 4).

SP = Standard Play LP = Long Play
SLP = Super Long Play

- LP recording is not possible in S-VHS/ S-VHS ET mode.
- Speed appears on-screen and on Multi Function Display.

4 Press REC to start recording.

- To edit out unwanted scenes, press PAUSE/SLOW to pause, and again to resume recording.
- You cannot view another channel during recording.

5 Press STOP to stop recording.

■ One Touch Recording (recording in progress),

- VCR shuts off after the preset record length.
- > each press of REC adds 30 min. to the record length up to 4 hours.

■ Record one station, watch another,

- > press VCR/TV ("VCR" goes out on Multi Function Display),
- > select channels at TV (recording continues).

■ Select channels at VCR,

- > press VCR/TV ("VCR" lights up on Multi Function Display),
- > select channels at VCR.

Notes

- **Watching one channel and recording another is NOT possible when using a Cable Box or a Satellite Receiver.**

- After 5 min. in Pause mode, VCR stops to protect tape and video head.

Record using VCR controls

- 2 Select Channel.
- 1 Insert a tape.
- 4 Press REC to start Recording.



- 5 Press STOP/EJECT to stop.
- VCR/TV
Multi Function Display

This video recorder, equipped with the HQ (High Quality) System, is compatible with existing VHS equipment. Only use those tapes with the **VHS** or **S-VHS** mark. It is recommended that only tapes tested and inspected for use in 2, 4, 6, and 8 hour VCR machines be used. This video recorder is equipped with recording functions for both conventional **VHS** and **S-VHS** systems to enable users to select either mode. An **S-VHS** cassette recorded in the **S-VHS** mode cannot be played back with conventional **VHS** VCRs.

✓ Ready Check List

- All connections are made (pg. 10, 12, 28).
- TV and VCR plugged in and turned on.
- VCR/TV selector set to "VCR."
- Clock set correctly.
- Tape has rec. tab (pg. 4).
- Remote is in VCR mode. (Press VCR)

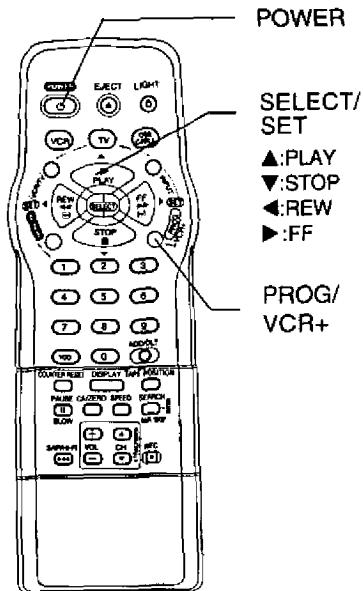

1 Press **PROG/VCR+** button* to display PROGRAM.

2 Press **▼** to display Program screen.

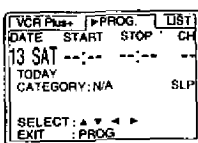

3 1) To set record DATE, press **▲ ▼** to select: 1 ~ 31= one time, or DAILY= MON ~ FRI, or WEEKLY= same time each week and press **▶** to set.
* See selection order below left.

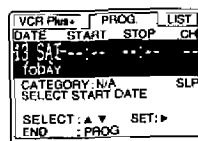

2) To set remaining items, press **▲ ▼** to select and press **▶** to set START/ STOP times, CH (channel) or LINE input (pg.44), Category** and tape speed (SP, LP, SLP).

Example
Today — 13 — 14—15.....31—1—2.....12
WEEKLY (SAT) WEEKLY (MON) WEEKLY (SUN) DAILY

**Category Items
N/A (not applicable),
SPORTS, MOVIE,
COMEDY, MUSIC, DRAMA

Press **PROG/VCR+** button to end the program.

Notes

- If you are using a Cable Box, VCR Timer Programming the Cable Box power must be left on.
- If a power interruption occurs while programming the timer, the timer program(s) may be canceled. If "TIMER PROGRAMS WERE LOST DUE TO POWER INTERRUPTION" appears on-screen, please reenter the timer programs.

4 To Enter More Programs, press **▲ ▼** to select and press **▶** to set an unused program number and repeat step 3.

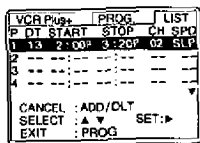

Or
Press **PROG/VCR+** button to exit.

5 Press **POWER** off to set the timer. ("TIMER" lights up on Multi Function Display.)

Review, Replace or Clear Program Contents:

(Recording is not in progress)

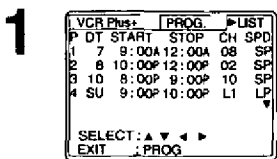

- 1) Press **PROG/VCR+** button.
- 2) Press **◀▶** to select LIST.

To cancel a Timer Recording in progress...

Press **POWER** and then press **STOP** within 10 seconds to cancel the Timer Recording. (The **TIMER** indicator goes out from Multi Function Display.)

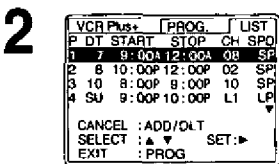

- Press **▲▼** to select number.

3 To Replace program...

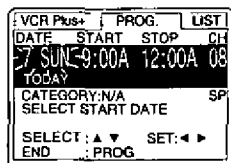

- 1) Press **▶** to display.
- 2) Repeat Step 3 (pg.20) to set new program.

or

To Clear program...

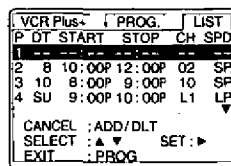

- Press **ADD/HLT**.

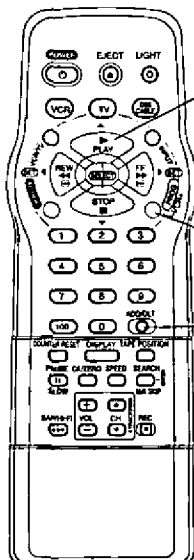

SELECT/
SET

▲:PLAY

▼:STOP

◀:REW

▶:FF

PROG/
VCR+

ADD/HLT

Timer
Recording

4 Press PROG/VCR+ button to end the program.

- If there are set programs, press **POWER** off to set timer.

Important notes when using a DSS Receiver

- When recording programs via a DSS Receiver, the DSS Receiver must be left on.
- When recording programs via an antenna or cable, the DSS Receiver must be turned off.

Auto VCR Plus+ System Channel Setup (Part 1)

In order for VCR to read PlusCode numbers, some setup is required. Guide channel numbers are assigned to each local broadcast and cable station.

Because this number sometimes differs from the channel your TV receives the station on, it is necessary to program the VCR with local channel information.

To receive VCR Plus+ channels automatically, perform the steps below.

Or, see "Manual VCR Plus+ System Channel Setup" section on page 24.

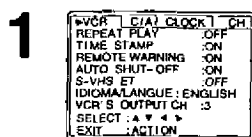

Press **ACTION*** to display MENU.

VCR Plus+ System is ...
a feature that allows you to set most items of a timer recording by simply entering a special code number (PlusCode programming number) found in TV GUIDE and selected newspaper TV listings.

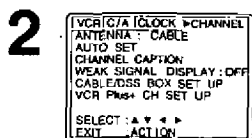

Press **◀▶** to select CHANNEL.

Important Note

• "Initial Setup" on pages 8 - 15 must be completed before "Auto VCR Plus+ System Channel Setup" can be done. If any part of setup is incomplete, a warning screen appears.

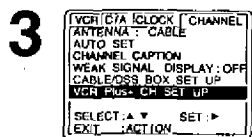

Press **▲▼** to select VCR Plus+ CH SET UP and press **▶** to display.

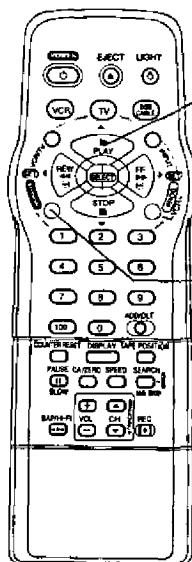

SELECT/SET
▲:PLAY
▼:STOP
◀:REW
▶:FF

ACTION

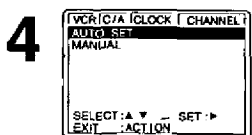

Press **▲▼** to select AUTO SET and press **▶** to set.

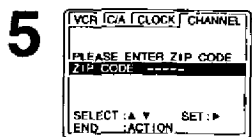

Press **▲▼◀▶** to enter Zip Code and enter each number. Press **▶** or **ACTION** to set.

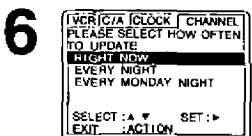

Press **▲▼** to select When to Update and press **▶** to set.

Notes

- Make each entry within 5 minutes, or VCR will leave this mode.
- Once local channels have been programmed, they will stay in memory, even in the case of a power failure.
- If the start time for a timer recording comes up during Auto VCR Plus+ System Channel Setup, the timer recording will have priority.

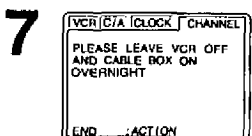

Press **ACTION** to end.

- Make sure to leave VCR off (overnight). If controllable, leave your Cable Box on.

Auto VCR Plus+ System Channel Setup (Part 2)

Before you perform the following steps, you should have:

- completed "Auto VCR Plus+ System Channel Setup (Part 1)" on page 22.
- left VCR off overnight, and turned it back on after 9:00 AM the next day.

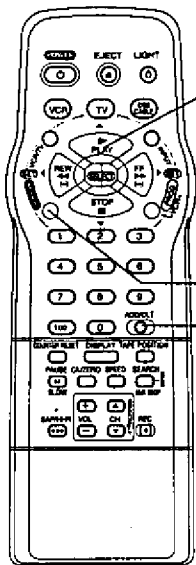

SELECT/SET

- ▲:PLAY
- ▼:STOP
- ◀:REW
- ▶:FF

ACTION

ADD/HLT

1 If channel updating was successful...

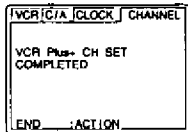

Press **ACTION** to exit this mode.

If VCR could not distinguish channel map...

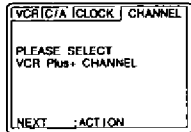

Press **ACTION** to display **SELECT VCR Plus+ Channel**. Continue with step 2.

2

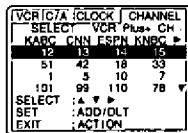

Press **▲▼◀▶** to select channel map for your area and press **ADD/HLT** to set.

3

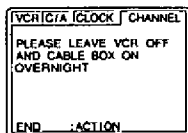

Press **ACTION** to end.

- Make sure to leave VCR off (overnight). If controllable, leave your Cable Box on.

Channel map will be updated (overnight). If it was successful, "VCR Plus+ CH SET COMPLETED" appears on screen. And then, press **ACTION** to exit.

Repeat these steps as necessary.

If Auto Setup fails, do "Manual VCR Plus+ System Channel Setup" on page 24.

To Change or Update Auto VCR Plus+ System Channel Setup

(E.g. you selected wrong channel map or zip code.)

- a Do "Auto VCR Plus+ System Channel Setup (Part 1)" steps 1 ~ 4 on page 22.

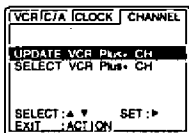

- b Press **▲▼** to select **UPDATE VCR Plus+** or **SELECT VCR Plus+ CH**, then press **▶**.
- c If you selected **UPDATE VCR Plus+ CH**, perform steps 5 ~ 7 in the "Auto VCR Plus+ System Channel Setup (Part 1)" section on page 22.

If you selected **SELECT VCR Plus+ CH**, perform steps 2 ~ 3 in the "Auto VCR Plus+ System Channel Setup (Part 2)" section on this page.

Recording timer

Initial Setup.....

In order to use Timer Recording Using VCR Plus+ System, the Initial Setup on page 8 to 15 must be completed for setting Clock and Channel.

Channel Setup.....

Since numbers assigned to channels found in TV Guide and selected newspapers may differ from channels in your viewing area, you'll need to enter your local TV channel number for each corresponding Guide Channel.

If you perform the VCR Plus+ Channel set up procedures shown below, you will be able to perform timer recordings using the PlusCode programming number listed in your local TV listing.

Manual VCR Plus+ System Channel Setup

For [VCR-TV] or [VCR-Cable Box-TV] connection only.

To complete step 5 of setup, do the following:

- Prepare a TV/Cable station line-up and channels they are received on. Also, the Guide channel numbers assigned to your stations (found in TV Guide and selected newspapers).

- Make a 3-column chart (see sample).

Left column

--> all stations you receive.

Middle column

--> each station's assigned Guide channel number from TV Guide, etc.

Right column

--> channel number on which your TV receives the station.

SAMPLE ONLY

Broadcast or Cable station name	Assigned Guide channel No.	Channel No. on which my TV receives the station.
HBO	33	15
Nickelodeon	38	20
CBS	04	04
FOX	11	

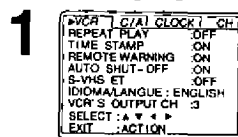

Press **ACTION*** to display menu.

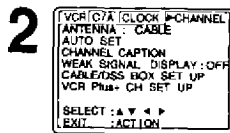

Press **◀▶** to select **CHANNEL**.

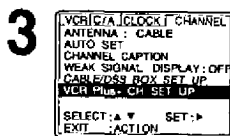

Press **▲▼** to select **VCR Plus+ CHANNEL SETUP**, and press **▶** to set.

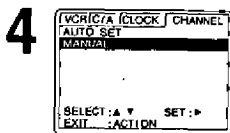

Press **▲▼** to select **MANUAL**, and press **▶** to set.

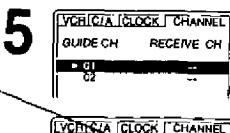

To enter VCR Plus+ channels, press **▶** to move cursor to right, press **▲▼** to enter number, press **◀** to set, and press **▲▼** to scroll up/down.

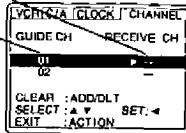

• Repeat step 5 until list is complete.

To Make Corrections,

press **▲▼** and **▶** to move to error, then **▲▼** to change, or **ADD/DEL** to erase number.

6 Press **ACTION** twice to end setup.

VCR Plus+ System Programming

Ready Check List

- Clock is set.
- VCR Plus+ Setup is complete (see pages 22 - 24).

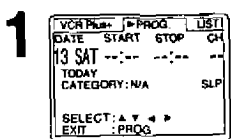

Press **PROG/VCR+** button to display **PROGRAM**.

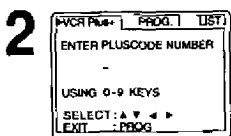

Press **◀▶** to select display VCR Plus+ screen.

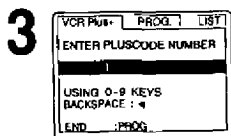

Press number keys to enter PlusCode number and press **PROG/VCR+** button to set.

To Make Corrections, press **◀** repeatedly to delete number, then repeat step 3.

- If the PlusCode number entered begins with "0", skip to step 5. Display in step 4 will not appear.

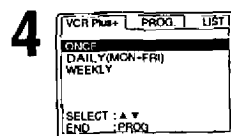

Press **▲▼** to select **ONCE**, **DAILY (MON-FRI)**, or **WEEKLY** record frequency and press **PROG/VCR+** button to set.

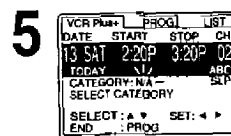

Press **▲▼** to select Category and record speed. Press **▶** to set. Press **PROG/VCR+** button to end program.

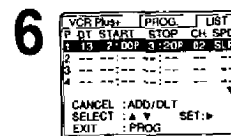

Press **PROG/VCR+** button to exit.

- Press **ADD/HLT** to delete the program.

7 Press **POWER** off to set the timer. ("TIMER" lights up on Multi Function Display.)

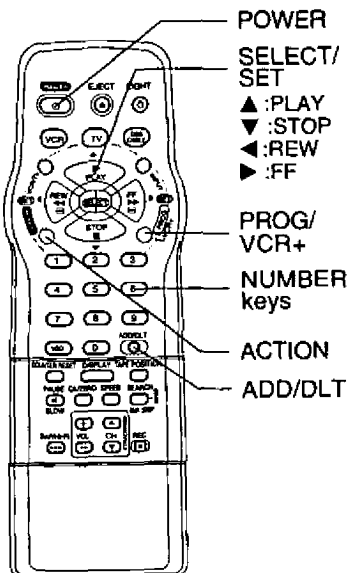

Do normal Timer Record if...

- PlusCode number is not listed for program.
- the program (e.g. sports event) may run over set stop time.

See page 21 to:

- cancel a timer recording in progress.
- review, replace, or clear program contents.

Important for DSS/ Cable Box Users

- When recording via DSS, the receiver must be left on. When recording via cable or antenna, DSS Receiver must be off.
- When recording via a Cable Box, leave box on.

Notes

- Do not overlap program times.
- Make each entry within 1 minute or the VCR will exit setup mode.
- Once VCR Plus+ channel setup is done, channels stay in memory. If a power interruption occurs, VCR Plus+ channel setup may be lost. Please do VCR Plus+ channel setup again.
- Obtain unlisted PlusCode numbers by calling 1 - 900 - 454 - 7587. Call costs about \$.95 per minute.

Timer Recording

TV Brand Code Numbers

Panasonic	01, 02	Sylvania	05	JVC	11
Quasar	01, 02	Sharp	06, 07	Hitachi	12
RCA	03	Sony	08	Mitsubishi	07, 13
GE	03	Toshiba	09	Samsung	14
Zenith	04	Sanyo	10	Gold Star	15, 16, 17
Magnavox	05	Fisher	10		

Cable Box Brand Code Numbers

Archer	05, 06, 01, 44, 63, 91, 126	Quest	05, 06
Cabletenna	01, 44, 63, 91, 126	Radio Shack	51, 44, 59, 75, 126
Cableview	63, 44, 42, 30, 52, 04, 124, 126	RCA	16, 17, 97, 109
Century	51, 44, 59, 75, 126	Realistic	51, 44, 59, 75, 126
Citizen	63, 44, 42, 30, 52, 04, 124, 126	Recoton	51, 44, 59, 75, 126
Curtis	08, 09, 61, 53, 87	Regal	14, 15, 28, 41, 102, 103, 104, 108, 130
Diamond	01, 44, 63, 91, 126	Regency	28, 130
Drake	67	Rembrandt	01, 32, 39, 42, 44, 63, 126
Eagle	13, 22, 58, 62, 20, 40, 26, 107	Salora	68
Eastern	28, 130	Samsung	05, 32, 40, 42, 06
GCBrand	63, 44, 42, 30, 52, 04, 124, 126	Scientific Atlanta	08, 09, 61, 53, 87
Gemini	04, 124	Sheritech	27
General Electric	57, 01	Signal	26, 112
General Instruments	01, 02, 03, 04, 34, 55, 83, 106, 65, 67, 68, 115, 117, 118, 124, 91	SL Marx	32, 40, 42, 06, 43, 44, 52, 63, 126
Hamlin	14, 15, 28, 41, 102, 103, 104, 108, 130	Sprucer	16, 17, 97, 109
Hitachi	31	Standard Components	32, 39, 42, 44, 126
Jasco	04, 124	Stargate	32, 40, 63, 44, 42, 30, 52, 04, 06, 124, 126
Jerrold	01, 02, 03, 04, 34, 55, 83, 106, 65, 67, 68, 115, 117, 118, 124, 91	Sylvania	19
Macom	31	Teknika	74
Magnavox	26, 112	Telecaption	77, 127
Matsushita	16, 17, 97, 109	Televue	32, 40, 42, 06
Movietime	32, 39, 42, 44, 126, 38, 40	Texscan	18, 19
NEC	38, 40, 32	Tocom	33, 34, 01, 42, 66, 91
NOVAVISION	08, 09, 61, 53, 87	Toshiba	36
NSC	38, 40, 32	Uniden Satellite	65
Oak	46, 11, 129	Unika	01, 44, 63, 91, 126
Oak Sigma	46, 11, 129	Universal	42, 43, 44, 52, 63, 126
Panasonic	16, 17, 97, 109	Videoway	07, 23, 50, 129
Philips	07, 13, 20, 23, 24, 50, 128, 129	Vid Tech	64
Pioneer	05, 06	Vidtek	64
Pulsar	63, 44, 42, 30, 52, 04, 124, 126	Viewstar	13, 22, 58, 62, 20, 40, 26, 107
		Zenith	07, 23, 50, 129

DSS Brand Code Numbers

Toshiba	92	Panasonic	96
Hitachi/Hughes	93	RCA	97
Magnavox/Uniden 1	94	Sony	98, 105
Magnavox/Uniden 2	95		

Important Notes

- Due to changes in infra-red commands used by manufacturers, some brands have several codes. If your unit does not respond to the first code, please try the next one.
- Some TV, Cable Box and DSS Receiver brands require you to turn on the power manually.

Audio/Video Connection

If your TV has AUDIO IN and VIDEO IN terminals, you can connect the VCR to them to receive higher quality picture and sound.

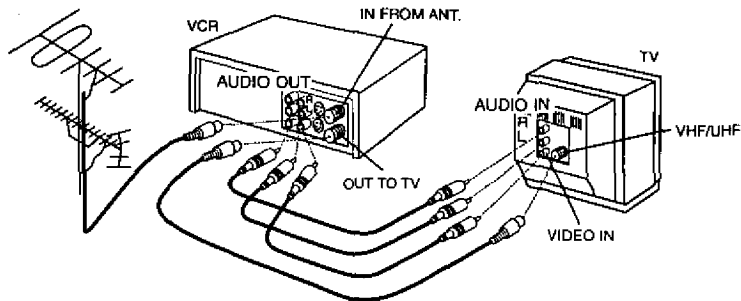

- 1 Connect the VIDEO OUT terminal on the VCR to the VIDEO IN terminal of your TV.
- 2 Connect the "L" and "R" AUDIO OUT terminals on the VCR to the "L" and "R" AUDIO IN terminals of your TV.
- 3 Set the VIDEO/TV selector of your TV (Monitor/Receiver) to "VIDEO."

With a Cable Box (VCR → Cable Box)

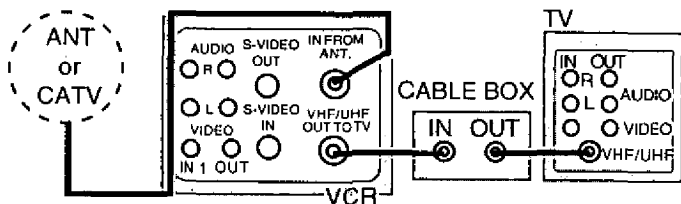

You Can

- view any (including scrambled) channel.
- use the VCR Remote to select channels without using Multi-brand control feature.

You Cannot

- record scrambled channels.

Connect With Two Cable Boxes

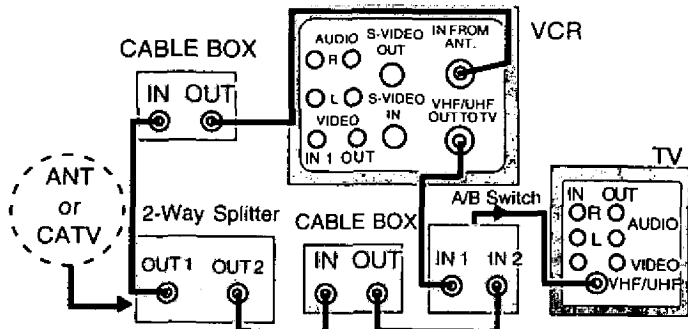

You Can

- record and view both scrambled and unscrambled channels if additional equipment is added. This connection requires: two converter boxes, an A/B switch, and a 2-way splitter.

You Cannot

- view channel other than the one selected for any type of recording.
- do a Timer recording of a channel unless you select it on the cable box.

MTS Stereo/VHS Hi-Fi Stereo System

Connection

Make the Audio/Video Connection as shown on the previous page.

- You can use a TV connected to Stereo amp and speakers instead of a Stereo TV.

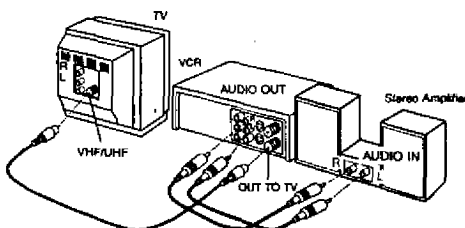

Receivable Broadcast Types

The following are possible audio broadcast types and on-screen displays.

The signal being received is indicated with an "Ⓢ" mark while the selected audio mode is indicated with an arrow.

To display the broadcast signal being received, → **press DISPLAY.**

MTS Stereo and SAP broadcast

Multi-channel Television Sound Stereo (main language) and Secondary Audio Program (sub language) broadcasts are being received simultaneously. Select STEREO or SAP audio mode.

MTS Stereo broadcast

Multi-channel Television Sound Stereo broadcast. Select STEREO audio mode.

- If stereo broadcast is weak and display flickers, select MONO audio mode for possibly better results.

SAP broadcast

Secondary Audio Program (sub language) broadcast. Select SAP audio mode for the sub language.

MONO broadcast

Normal monaural sound broadcast.

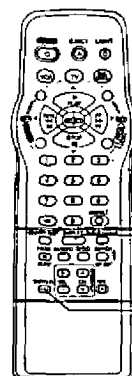
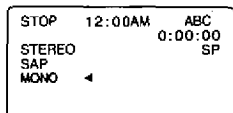
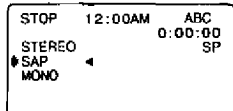
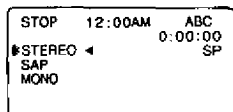
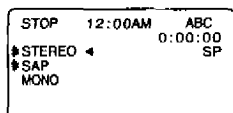

Equipped with **dbx**[®]-TV Noise Reduction for true MTS reproduction. **dbx**[®]-TV Noise Reduction is required for good stereo separation and audio fidelity. **dbx**[®] is a registered trademark, and is licensed by **dbx**[®] Technology Licensing.

Audio Mode for Recording

- 1 Press **SAP/Hi-Fi** to display audio mode. (Display disappears after 5 seconds.)

- 2  Press **SAP/Hi-Fi repeatedly** to select desired mode.

- Refer to "Receivable Broadcast Types" above.

- 3 Do a recording. See page 19.

Notes

- Only tapes recorded in Hi-Fi stereo will playback with true stereo sound. Standard stereo tapes will playback in monaural sound.
- To listen to Hi-Fi stereo playback, the VCR AUDIO (L/R) jacks must be connected to a stereo TV or an external stereo amp and speakers. (See top of this page.)
- If tracking is adjusted during playback, Hi-Fi audio may revert to normal audio.
- Hi-Fi and normal audio playback volume level may differ.

Audio Mode for Playback

- 1 Start playback. See page 18.
- 2 Press **SAP/Hi-Fi** to display audio mode. (Display disappears after 5 seconds.)
- 3 Press **SAP/Hi-Fi repeatedly** to select desired mode.

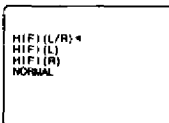

- Select "HIFI (L/R)" or "HIFI (L)" or "HIFI (R)" to listen to stereo recordings in stereo sound. Select "NORMAL" for monaural sound.

- Arrow indicates selection.

COMMERCIAL ▶▶ ADVANCE®

COMMERCIAL ▶▶ ADVANCE® detects and marks the beginning and end points of commercials on your tape for recordings over 15 minutes in length. When a COMMERCIAL ▶▶ ADVANCE® marked tape is played back, the VCR automatically advances through the commercial segments at high speed. You can also set this feature to Manual so as to have more control over the advance process. The effectiveness of this system can vary due to differences in the way television stations broadcast. See page 32 for answers to the most commonly asked questions about this feature.

Ready Check List

- All connections are made.
- One time Setup completed.
- VCR is plugged in.
- TV is turned on and set to CH3, 4 or Video on TV.

COMMERCIAL ▶▶ ADVANCE® Marking

When C/A RECORD: ON, VCR automatically rewinds the tape after a recording has been made and marks the beginning and end of any detected commercial blocks. After marking is done, the tape is returned to the end of the recording. Commercials are not erased from the tape.

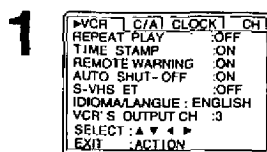

Press **ACTION**® to display MENU.

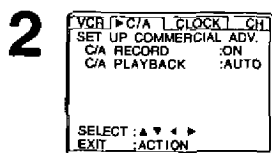

Press **◀▶** to select C/A and display SET UP COMMERCIAL ADV.

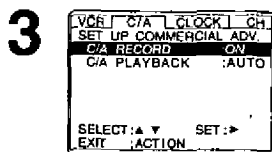

Press **▲▼** to select C/A RECORD and press **▶** to set.

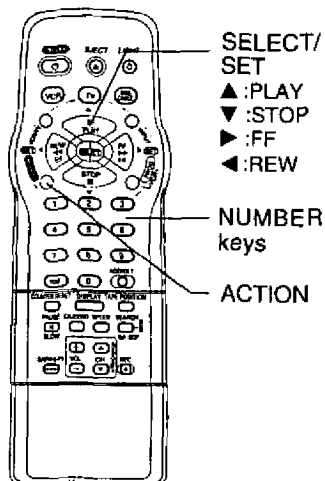

Note

- When using the timer to record two adjacent shows on the same channel, better accuracy can be obtained by programming each shows separately.

ON Timer, VCR Plus+ System, and One Touch recordings are marked automatically.

THE VCR IS WAITING TO MARK COMMERCIALS IN THE PROGRAM YOU RECORDED.

MARKING
NOW :PRESS 1
LATER :PRESS 2
CANCEL :PRESS ACTION

When STOP is pressed during normal recording, Select one of a) or b) or c).

- a) Press 1 key to mark the recording now. "NOW MARKING COMMERCIALS" appears.
- b) Press 2 key to mark the recording later (after the power has been turned off).
- c) Press ACTION to cancel the marking of this recording.

OFF The VCR will not mark commercials.

When you are editing or dubbing a tape, or when you do not wish to use this feature, OFF should be selected.

4 Press **ACTION** to return to normal screen.

COMMERCIAL--ADVANCE® Playback

When playing back a recording which has been marked using the **COMMERCIAL--ADVANCE®** feature, you can either set VCR to automatically advance through marked commercial blocks, or set it so that commercials are only skipped on your command.

PLAY

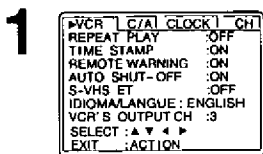

Press ACTION
to display MENU.

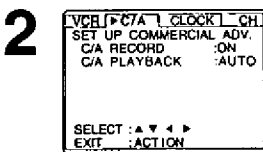

Press ◀▶
to select C/A
and display SET UP
COMMERCIAL ADV.

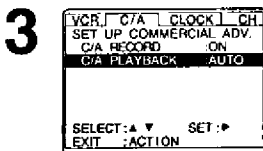

Press ▲▼
to select C/A
PLAYBACK
and
press ▶ to set AUTO or
MANUAL.

AUTO VCR will automatically advance through marked commercial blocks recorded on the tape and then resume playback.

MANUAL VCR will advance through commercials only when CAZERO is pressed. Playback will resume when the end mark of a commercial block is found, or a new recording or blank portion is detected, or after 8 minutes.

4 Press ACTION
to return to normal screen.

Notes

- The selection mode in step 3 remains set unless there is a power outage in which case the original factory setting will be restored.
- If playback is started in the middle of a commercial, only a single commercial is shown, or an individual commercial is longer than 1 minute, the commercial may not be skipped. Press FF to quickly advance through the commercial.
- Part of a recorded program may be skipped over if the program portion between commercials is less than one minute or there are frequent dark and quiet scenes during the program. To view the portion of tape being incorrectly skipped, press PLAY while the VCR is skipping, reverse the tape to a point just prior to where the skipping began and press PLAY again. This time the group will not be automatically skipped. Automatic skipping will be re-enabled when the end of the marked group is detected.

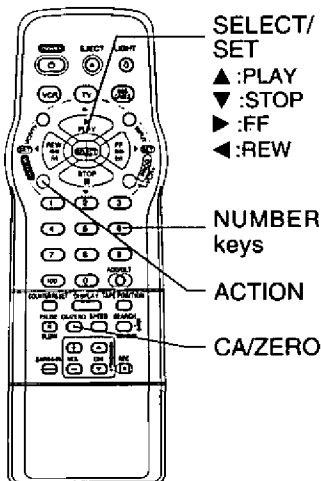

SELECT/
SET

▶:PLAY
▼:STOP
▶:FF
◀:REW

NUMBER
keys

ACTION

CA/ZERO

COMMERCIAL--ADVANCE® and
MOVIE--ADVANCE® are
registered trademarks of SRT, Inc.
A Jerry Iggulden invention licensed
in association with Arthur
D. Little Enterprises, Inc.

U.S.Pat. No. 5,333,091;
5,692,093; 5,696,866
other patents pending

Advanced
Operation

Tape Operation (continued)

The most commonly asked questions about **COMMERCIAL**→**ADVANCE**[®] are answered below.

Question	Answer
How fast does the VCR advance through commercials?	The VCR advances through a 3-minute commercial block in about 8 to 12 seconds if the tape speed is SLP. In SP, it takes about 25 to 35 seconds.
Are commercials advanced through only when I playback a recording?	Yes. The commercials are not marked until after the recording is finished.
Are commercials still recorded on the tape in case I choose to view them sometime?	Yes. By setting the C/A PLAYBACK to MANUAL (see page 31), you can view or advance through commercials as desired.
Does COMMERCIAL → ADVANCE [®] work in all recording speeds?	Yes. COMMERCIAL → ADVANCE [®] works in SP, LP, and SLP.
Does the VCR advance through commercials each time I playback tapes which were recorded using COMMERCIAL → ADVANCE [®] ?	Yes. As long as C/A PLAYBACK is set to AUTO (see page 31), the VCR should advance through commercials each time the tape is played back.
After marking commercials, does the VCR stop at the end of the tape, or rewind to the beginning?	The tape stops at the end of the recording so that any additional timer recordings can be performed.
Can I play my COMMERCIAL → ADVANCE [®] recordings in non- COMMERCIAL → ADVANCE [®] VCRs?	Yes. COMMERCIAL → ADVANCE [®] marked recordings will play in non- COMMERCIAL → ADVANCE [®] VCRs, but commercials will not be advanced through.
Does the marking process interfere with other programmed recordings?	No. If the interval between 2 or more timer programs is not sufficient to mark the recording, marking will be done after all recordings are complete and the power goes off.
What happens if I cancel the marking in progress so I can use the VCR?	Marking will be resumed when the VCR's power is turned off as long as the tape has not been ejected.
What if part of my program is advanced through along with the commercials?	Please see the 3rd note on page 31.
Additional Notes: <ul style="list-style-type: none">• Because of the various ways in which commercials are broadcast, the VCR may not be able to recognize all commercials.• If a timer recording is scheduled for the middle of the night, please be aware that the VCR will make some noise as it rewinds and fast forwards the tape while marking commercials.	

COMMERCIAL→**ADVANCE**[®] and **MOVIE**→**ADVANCE**[®] are registered trademarks of SRT, Inc.
A Jerry Iggulden invention licensed in association with Arthur D. Little Enterprises, Inc.

U.S.Pat. No. 5,333,091;
5,692,093; 5,696,866
other patents pending

Important: If a remote control button does not work when pressed, press the VCR button on the remote and try the button again.

MOVIE ▶ ADVANCE®

MOVIE ▶ ADVANCE® helps you locate certain parts of prerecorded movies (rented or purchased).

The feature works in two ways.

- You can go to the beginning of the movie.
- You can skip from one preview to the next.

MOVIE ▶ ADVANCE® works only on cassettes recorded in SP speed with the record tab removed.

1 Insert a cassette without record tab.

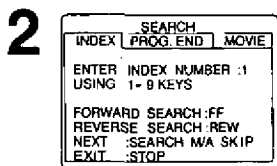

Press **SEARCH/M/A SKIP*** to display SEARCH.

- If you inserted a cassette with the record tab or if you selected "INDEX SEARCH" go to page 34.

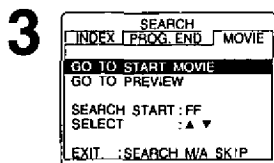

Press **SEARCH/M/A SKIP** twice to select MOVIE and press **▲▼** to select GO TO START MOVIE or GO TO PREVIEW.

Select "GO TO START MOVIE," if you want to advance directly to beginning of the movie.
--> continue with step 4.

Select "GO TO PREVIEW," if you want to view the first (next) preview.
--> go to "To Search for Preview" at right.



Press **FF** to start searching.

- To cancel, press STOP.

When the movie is found...

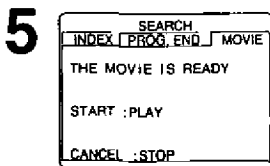

Press **PLAY** to start playback.

- To cancel, press STOP.

Ready Check List

- All connections are made.
- One time Setup completed.
- VCR is plugged in.
- TV is turned on and set to CH3, 4 or Video on TV.

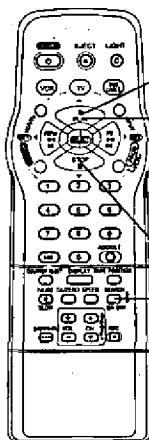

PLAY

SELECT/SET

▲ :PLAY

▼ :STOP

▶ :FF

STOP

SEARCH M/A SKIP

To Search for Preview.

You can override the operation of MOVIE ▶ ADVANCE® SEARCH FOR PREVIEWS mode by pressing SEARCH/M/A SKIP during tape searching.

MOVIE ▶ ADVANCE® works by searching the tape past each preview and then reversing back to the start of the detected preview. While the tape is reversing back, if SEARCH/M/A SKIP is pressed, MOVIE ▶ ADVANCE® will begin searching for the next preview. While searching for the next preview, if you see the start of a preview which you wish to watch, press SEARCH/M/A SKIP and MOVIE ▶ ADVANCE® will immediately reverse back to the start of that preview, instead of searching further past the preview start point.

Once the VCR is playing a preview, press SEARCH/M/A SKIP to advance to the next preview, long commercial or the start of the movie (whichever is next).

1 Start preview searching.

1) In step 3 at left, select "Go To PREVIEW"

2) Press **▶**

- If you want to playback, press PLAY.

When a preview is detected, VCR will start playback.

2 Start next preview searching.

Press **SEARCH/M/A SKIP**.

- To cancel, press STOP.

Advanced Operation

Search System

For each recording, an invisible index mark is placed on the tape.
A program index and information are also included for timer recordings.
These marks are used to access or scan recordings.

Index Search

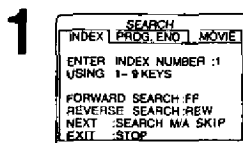

Press SEARCH/ M/A SKIP* to display SEARCH in Stop or Play mode.



Press number keys to select recording number.

- To calculate number, see below.

Press FF or REW to start search.

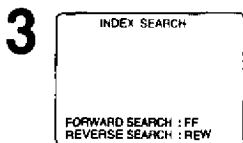

Play begins at search end. To search forward or back 1 index, **press FF or REW** while screen left is displayed (10 sec.).

To Calculate Index Number

Example 1:

To go to rec. 2 from rec. 4, enter 3 and press REW.



Example 2:

To go to rec. 6 from rec. 2, enter 4 and press FF.



NOTE: ↓ indicates start points of each recording.

Note

- If Index Search is started very close to an index mark, that index mark may not be counted in the search.

Program End Search

Locates end point of recording for continuity.

1 Press SEARCH/ M/A SKIP twice to display SEARCH in Stop or Play mode.



Press FF to start PROGRAM END SEARCH.

Examples of Program End Search.

Fig. 1



Fig. 2

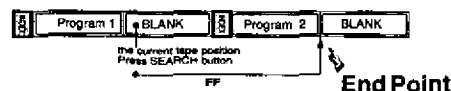
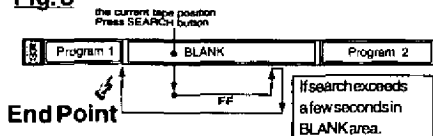

Fig. 3



Upon locating end point,

- >search continues 7 sec. past end point,
- >tape rewinds to 10 sec. before end point,
- >tape plays to end point and stops.

Notes

- If Program End Search is started very close to an index mark, that mark may be skipped over.
- To cancel, press PLAY or STOP.

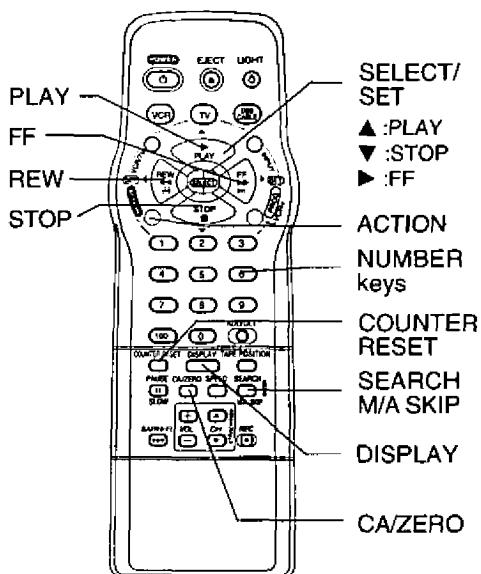

Zero Search

To quickly return to a specified tape location.

- 1 Press **DISPLAY** during play to display Counter.

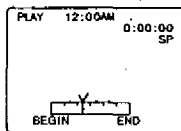

Press **COUNTER RESET** at desired position to reset to "0:00:00".

- 3 Continue to record, playback etc.

- 4 Press **STOP**.

- 5 Press **CA/ZERO** in Stop mode to start ZERO SEARCH.

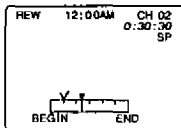

- Unit will go into FF or REW mode and stop at the last point the Counter was set to 0:00:00.

Note

- If a blank portion exists on the tape, and depending on the position of the V mark, the V mark display position may not be accurate.

Repeat Play

Set to playback a recording over and over.

- 1 Press **ACTION** to display MENU.

- 2 Press **▲▼** to select **REPEAT PLAY** and press **▶** to set ON or OFF.



- Play repeats at tape end or if unrecorded portion over 30 seconds is detected.

- 3 Press **ACTION** to return to normal screen.

Auto Operation Functions

Auto Play

Insert tape --> Power comes on, --> Play starts if no record tab (see pg. 4).

Auto Rewind

Play
Manual Record } --> Tape end,
Fast Forward } --> Rewind

Play Auto Eject

(Repeat Play must be off)
Play, --> Tape end, --> Rewind,
--> Tape ejects if no record tab

Channel Caption

When set, station name, e.g. ABC, CBS, and channel number appear on-screen. Set up to 24 preset captions, and/or 10 manually created captions.

You need a list of stations and the channel numbers you receive them on.

Preset Caption

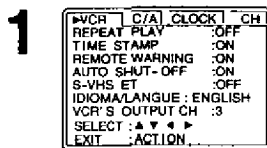

Press **ACTION*** to display MENU.

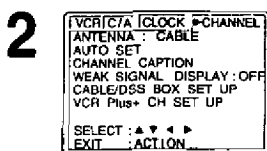

Press **◀▶** to select CHANNEL.

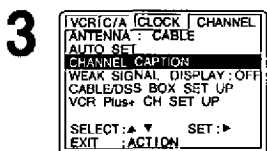

Press **▲▼** to select CHANNEL CAPTION and press **▶** to set.

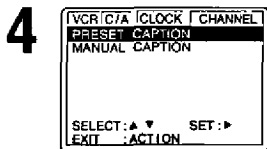

Press **▲▼** to select PRESET CAPTION and press **▶** to set.

• To create your own captions, go to "Manual Caption" on page 37.

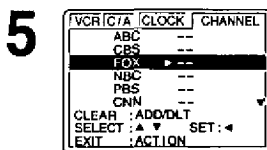

Assign preset captions.

- 1) Press **▲▼** to highlight caption.
- 2) Press **▶** to move cursor to the right.
- 3) Press **▲▼** to select CH number.
- 4) Press **◀** to set.

• Repeat step 5 until the list is complete.

To make corrections,

Press **▲▼** and **▶** to select the channel number, then press **▲▼** to change, or ADD/DLT to delete the number.

6 Press **ACTION** twice to end setup.

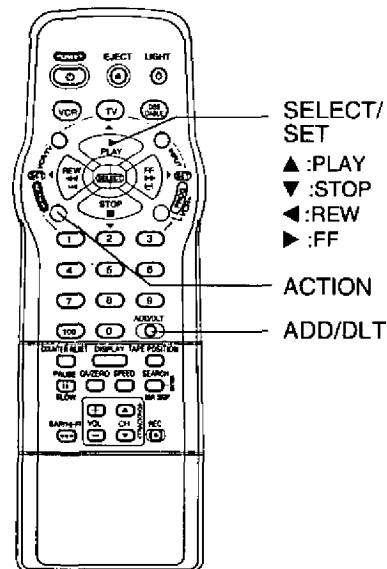

Manual Caption

1 Do "Preset Caption" steps 1 ~ 3 on page 36.

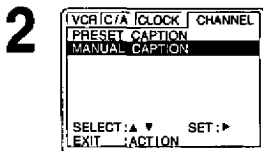

Press ▲▼ to select **MANUAL CAPTION** and press ► to set.

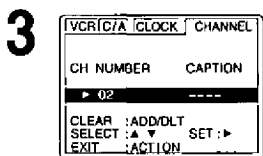

Press ▲▼ to select **CH NUMBER** and press ► to move cursor to the right.

- Channels already set and channels deleted from Channel Memory are not displayed.
- You can set a total of ten channel captions.

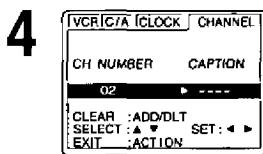

Press ▲▼ to enter **CAPTION** and press ◀ to set.

- Characters change in following order.

→ A ↔ B ↔ C ↔ ... ↔ Z ↔ BLANK ↔ — ↔ & ↔ ◀
 → 9 ↔ ... ↔ 2 ↔ 1 ↔ 0 ↔ + ↔ - ↔ 1 ↔ ←

- Repeat steps 3 and 4 as desired.

To make corrections,

Press ◀▶ to move to the incorrect entry, then press ▲▼ to make correction.
 Or, press ADD/HLT to clear the caption.

5 Press **ACTION** twice to end setup.

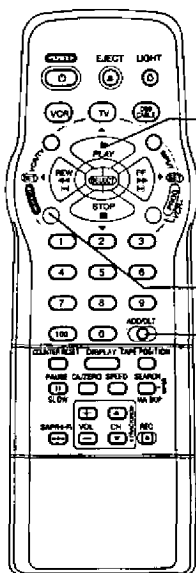

SELECT/
SET

▲:PLAY
▼:STOP
◀:REW
▶:FF

ACTION

ADD/HLT

Time Stamp Feature

The VCR writes program data (see example below) about the first 10 seconds of every recording.

The information is then displayed the first 10 seconds of playback.

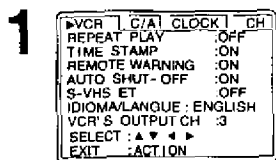

Press **ACTION*** to display MENU.

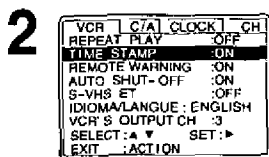

Press **▲▼** to select **TIME STAMP** and to select **ON** or **OFF** and press **▶** to set.

- When "OFF" is selected, the program data is written on the tape, but will not be displayed.

3 Press **ACTION** to return to normal screen.

Ready Check List

- Clock is set to correct time.
- Record tab in place. (See page 4.)

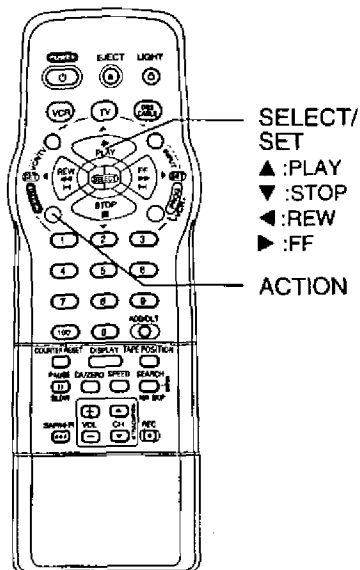

<Time Stamp Example>

One Touch Recording

11/11/2001 SUN
12:00PM
CH 08 ABC

Timer Recording

11/11/2001 SUN
12:00PM - 1:00PM
CH 08 ABC MOVIE

When Clock is not set...

---/---/---

CH 08 ABC

Important: If a remote control button does not work when pressed, press the VCR button on the remote and try the button again.

Tape Position and Tape Status Feature

To find out the present tape position and amount of tape remaining.

Tape position cannot be detected for VHS-C Cassettes, tapes under 30 minutes, and some other tapes:

1 Press TAPE POSITION
to detect current tape position.



- "DETECTING TAPE POSITION" is displayed only when a cassette is first inserted, and it takes several seconds for correct tape position to appear.

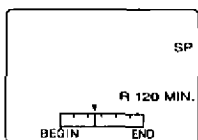

- The present tape position indication and amount of tape remaining (according to tape speed) is displayed.
- Tape remaining time display may not be precise.

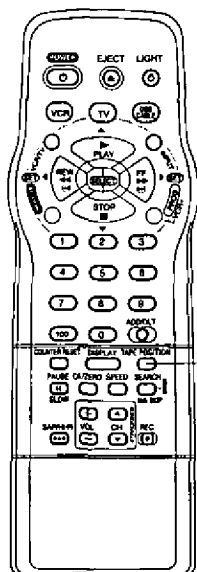

TAPE
POSITION

2 Press TAPE POSITION
to return to normal screen.

Note

- This function cannot display exact amount of tape remaining for tapes 30 minutes or less, or for tapes over 120 minutes in length.

Special VCR Features (continued)

VCR Lock Feature

When set to ON, all operations except for timer record and tape eject are prohibited. Useful for households with small children.

VCR LOCK ACTIVATED

To turn on,
hold down REC on the VCR in Stop mode with no tape inserted for 7 sec. (Please ignore the NO CASSETTE warning.)

VCR LOCK OFF

To turn off,
repeat above.

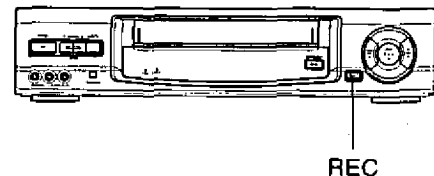

- VCR Lock cancels in 24 hours if clock is set.

Auto Shut-Off Feature

When set to ON, VCR shuts off if blank tape is played or no signal is detected for 5 minutes.

1 Press ACTION*
to display menu.

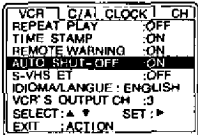
2  **Press ▲▼**
to select
AUTO SHUT-OFF and
press ►
to set ON or OFF.

3 Press ACTION
to return to normal screen.

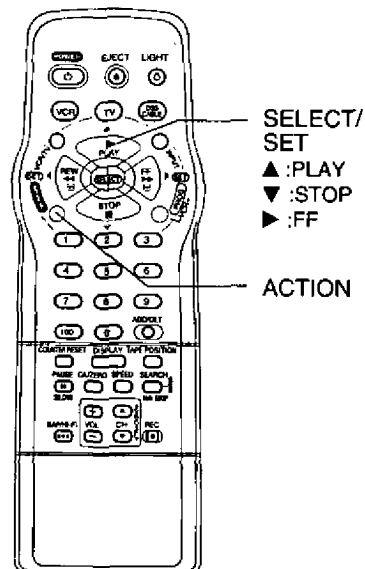

Weak Signal Display ON/OFF Feature

When "ON," picture is displayed regardless of signal strength.

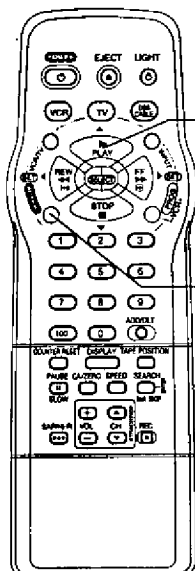

SELECT/
SET

▲:PLAY

▼:STOP

◀:REW

▶:FF

ACTION

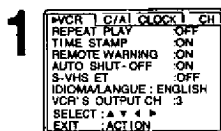

Press **ACTION**
to display menu.

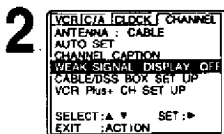

Press ◀▶
to select and
display CHANNEL,
press ▲▼
to select WEAK
SIGNAL DISPLAY,
and
press ▶
to set ON or OFF.

- ON: Picture is displayed regardless of signal condition, and may not always be clearly visible.
- OFF: Screen turns solid blue when signal is weak or non-existent.
- Selecting ON has no effect on connected equipment with blue back feature.

3 Press **ACTION**
to return to normal screen.

Remote Warning ON/OFF Feature

If Multi-brand feature is used (page 26), and this feature is set to on, a warning appears whenever an invalid key is pressed in TV, DSS, or Cable mode.

1 Press **ACTION**
to display menu.

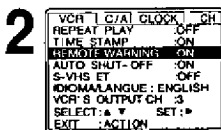

Press ▲▼
to select REMOTE
WARNING and
press ▶
to set ON or OFF.

- If "OFF," remote warning will not appear if invalid key is pressed.

3 Press **ACTION**
to return to normal screen.

S-VHS (S) VHS System

S-VHS tape playback is superior to VHS, even when using a conventional TV. And, your S-VHS VCR can also playback VHS format tapes.

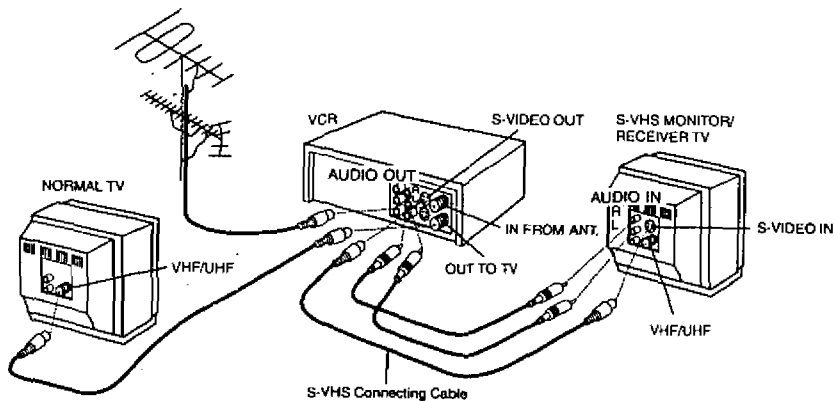

Selecting the S-VHS/ S-VHS ET System

- 1** Press **ACTION*** to display MENU.

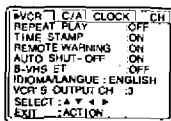

- 2** Press **▲▼** to select S-VHS ET.



- 3** Press **▶** repeatedly. Display will change as below.

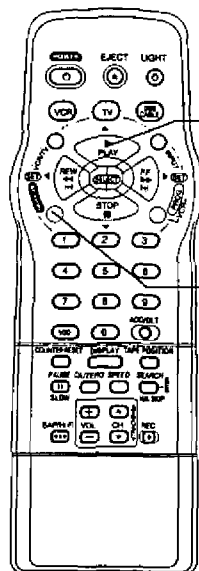
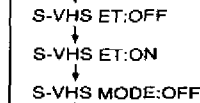
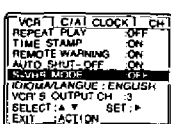

SELECT/
SET
▲ :PLAY
▼ :STOP
▶ :FF

ACTION

When S-VHS ET turns on or off, S-VHS mode turns on. See next page for details.

- 4** Press **ACTION** to return to normal screen.

Super VHS ET

Your VCR is equipped with S (Super) VHS ET. This facility allows recording with S-VHS picture quality on VHS cassettes. You can then playback S-VHS ET recordings on a VCR equipped with S-VHS ET.



S-VHS ET indicator

- The "S-VHSET" indicator lights up on the front display panel.

Notes

- S-VHS ET does not work with S-VHS tapes.

Super-VHS and VHS Tapes

- Both S (Super)-VHS and VHS recordings can be made on an S-VHS tape.
- When an S-VHS tape is inserted, the S-VHS ET will not work.
- Select "S-VHS ET ON" when recording on an HG-VHS tape in S-VHS ET mode.
- Both S-VHS ET and VHS recordings can be made on a VHS tape.
- Tapes recorded in VHS may be played back on either an S-VHS or VHS type VCR.
- Tapes recorded in S-VHS (S-VHS ET) cannot be played back on a conventional VHS VCR.

Quality Record Settings	Cassette Tape		
	SUPER VHS	HG-VHS	VHS
S-VHSET: OFF	S-VHS	VHS	VHS
S-VHSET: ON	S-VHS	S-VHS ET	*S-VHS ET
S-VHSMODE: OFF	VHS	VHS	VHS

* It is not recommend to do an S-VHS ET recording on a VHS tape.

Compatibility

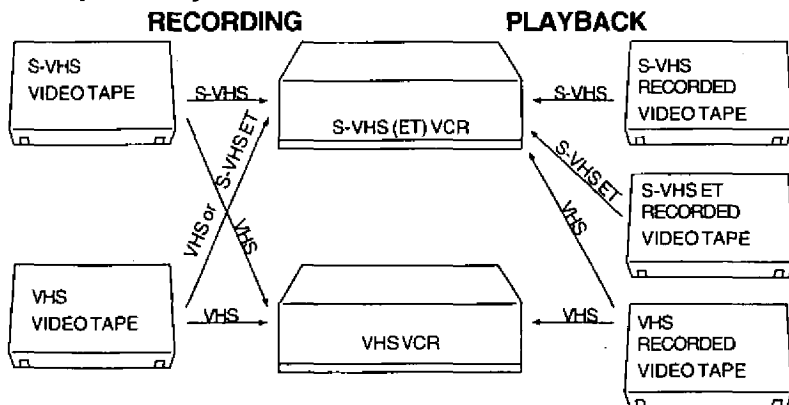

Connection

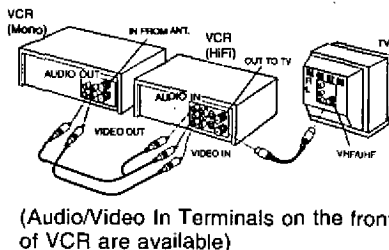
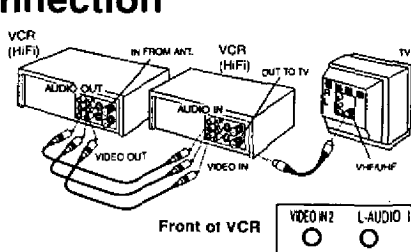

- 1 Connect VIDEO OUT terminal on Playing VCR to VIDEO IN terminal on Recording VCR. To monitor the dubbing, also connect a TV as shown.
- 2 Connect "L" and "R" AUDIO OUT terminals on Playing VCR to "L" and "R" AUDIO IN terminals on Recording VCR.

In place of a Playing VCR, you can use other equipment, such as a Camcorder. Simply connect the unit's Audio/Video outputs to the Recording VCR.

Playing (Source) VCR

Recording (Editing) VCR

- | | |
|---|---|
| <ol style="list-style-type: none"> 1 Insert pre-recorded tape. 2 _____ 3 Press PLAY, then PAUSE/SLOW immediately to enter PLAY/PAUSE mode. | <p>Insert blank tape with record tab.</p> <ol style="list-style-type: none"> 3 Press REC, then PAUSE/SLOW immediately to enter REC/PAUSE mode. |
| <p>The operation of steps 4 and 5 must be done on both playing and recording VCRs at the same time.</p> | |
| <ol style="list-style-type: none"> 4 Press PLAY to start dubbing. Playing VCR starts playback. 5 Press STOP to stop dubbing. | <ol style="list-style-type: none"> 4 Press PAUSE/SLOW to start dubbing. Recording VCR starts recording. 5 Press STOP to stop dubbing. |

■ To Monitor Dubbing on Your TV

- 1 Turn your TV on and tune to the Recording VCR channel (CH3 or CH4).
- 2 Set the VCR/ TV Selector on the Recording VCR to "VCR."

■ Selecting the Input Mode

- Method 1: Press INPUT repeatedly.
Channel Number <-> LINE1 <-> LINE2
- Method 2: Press CH ▲/▼. Display will change as below.

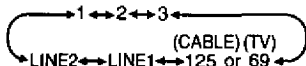

Note

- Dubbing tapes protected with Copy Guard will have poor quality results.

- "L1" or "L2" lights up on Multi-Function Display (about 4 sec.) when LINE1 or LINE2 is selected.
- LINE1: For rear audio/video connection.
- LINE2: For front audio/video connection.

Caution: Unauthorized exchanging and/or copying of copyrighted recordings may be copyright infringement.

Head Cleaning

Playing older or damaged tapes may eventually cause video heads to become clogged.

Video Head Clog Sensor

During playback, this screen appears if clogging is detected. To remove screen, press PLAY on the remote or VCR.

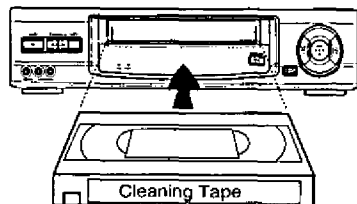
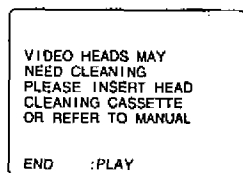

- Use "dry" type head cleaning cassette only. (Part No. NV-TCL30PT is recommended.)
- Follow cleaning tape instructions carefully. Excessive use of tape can shorten head life.
- If head clog symptoms persist, contact your nearest Factory Service Center or authorized Service Center. (See page 50.)

Cleaning the VCR

Use a soft cloth or dusting attachment of a vacuum cleaner to remove dust from the ventilation holes on the back sides and bottom of the cabinet.

Plastic surfaces are easily scratched and can be marred by alcohol and various solvents. Avoid excessive use of oil-based furniture polishes since the materials used in the cabinet will accumulate more dust. We recommend using a nonabrasive, antistatic cleaner and polisher.

Specifications

Power Source:	120 V AC, 60 Hz
Power Consumption:	<u>Power On</u> Approx. 28 watts <u>Power Off</u> Approx. 3.7 watts
Video Signal:	EIA Standard NTSC color
Video Recording System:	4 rotary heads helical scanning system
Audio Track:	1 track (Normal) 2 channel (Hi-Fi Audio Sound)
Tuner:	
Broadcast Channels:	VHF 2 ~ 13, UHF 14 ~ 69
CABLE Channels:	Midband A through I (14 ~ 22), Superband J through W (23 ~ 36) Hyperband AA ~ EEE (37 ~ 64), Lowband A-5 ~ A-1 (95 ~ 99) Special CABLE channel 5 A (01), Ultraband 65~94, 100 ~ 125
S-VIDEO	
Input/Output Level:	S-VIDEO CONNECTOR (SEPARATED YC CONNECTOR) Y CONNECTOR 1.0 Vp-p. (75 ohm unbalanced) C CONNECTOR 0.286 Vp-p. (75 ohm unbalanced)
Operating Temperature:	5 °C ~ 40 °C (41 °F ~ 104 °F)
Operating Humidity:	10 % ~ 75 %
Weight:	3.5 kg (7.7 lbs).
Dimensions:	430 (W) x 98 (H) x 242 (D) mm 16-15/16" (W) x 3-7/8" (H) x 9-9/16" (D)

Note: Designs and specifications are subject to change without notice.

Features for a Quality Picture

Digital Auto Picture

Automatically controls the video output signal for less noise depending on the tape condition.

Digital Auto Tracking

Continuously analyzes the signal and adjusts for optimum picture quality.

Manual Tracking Control (to reduce picture noise)

Use during Playback and Slow Motion mode to reduce picture noise. Press CH (TRACKING) ▲ / ▼ buttons on the remote control or on the VCR until the picture clears up. To return to Auto Tracking, press POWER off, then on again a few seconds later.

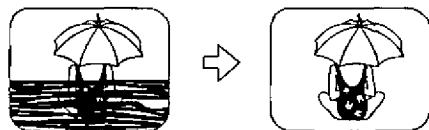

V-Lock Control (to reduce picture jitter)

In Still mode, CH (TRACKING) ▲ / ▼ buttons operate as a V-Lock control.

CNR (Color Noise Reduction)/ANR (Advanced Noise Reduction)

Color Noise Reduction reduces the color noise. Advanced Noise Reduction reduces the luminance noise.

On-Screen Displays (OSD)

Function & Channel Display

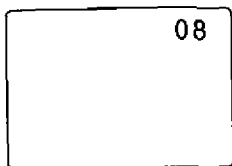

When a function button is pressed, e.g. PLAY, or you change channels, a few second display appears first in large and then small characters.

VCR Status & Clock Display

To display or remove overlay below,

--> press DISPLAY.

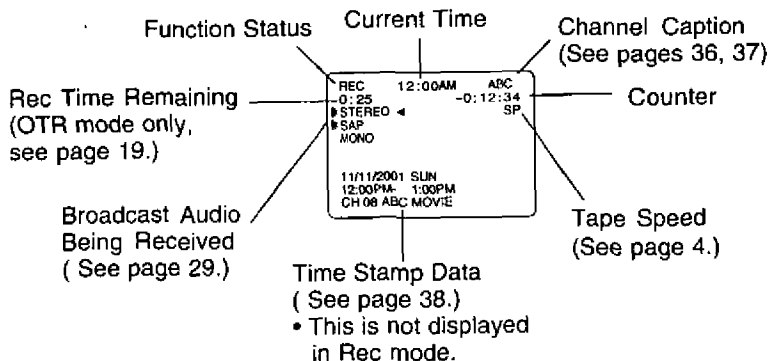

Blank Tape/ No Video Signal Indication

Whenever a blank section of a tape comes up in Play mode, or when the selected channel has no broadcast signal with the Weak Signal Display Feature (page 41) set to OFF, the TV screen will turn solid blue.

Warning and Instruction Displays

These displays will alert you to a missed operation or provide further instructions.

OSD	Caution	Pg	OSD	Caution	Pg
NO CH FOUND PLEASE CHECK ANTENNA CABLE CONNECTION THEN PRESS CH UP KEY AGAIN	If no active channels are found for CHANNEL MEMORY...	10 12	TO CANCEL TIMER REC PRESS POWER THEN STOP KEY	If you press POWER or STOP during a Timer Recording... (visible in VCR mode only)	21
PLEASE SET CLOCK BY PRESSING ACTION KEY	If you attempt to set or review a Timer Recording and the Clock is not set...	20	VIDEO HEADS MAY NEED CLEANING PLEASE INSERT HEAD CLEANING CASSETTE OR REFER TO MANUAL END :PLAY	If head cleaning becomes necessary while playing back a tape...	45
TURN VCR OFF FOR TIMER RECORDING	After a Timer Program has been set...	20	VCR LOCK ACTIVATED	If you press a function button other than STOP/EJECT or POWER while the VCR is in VCR Lock mode...	40
CHECK CASSETTE RECORD TAB	If you press REC on the remote control or VCR, and a cassette is inserted with no record tab...	4	REMOTE CONTROL IS SET TO CABLE/DSS MODE USE VCR : VCR KEY USE TV : TV KEY	If you press an invalid key on the remote while in CABLE/DSS mode...	26 27 41
NO CASSETTE PLEASE INSERT A CASSETTE	If you press PLAY, FF, REW, or REC on the remote control or VCR without a cassette inserted...	18 19	REMOTE CONTROL IS SET TO TV MODE USE VCR : VCR KEY USE CABLE/DSS : CABLE/DSS	If you press an invalid key on the remote while in TV mode...	26 27 41

Check the following points once again if you are having trouble with your VCR.

Power

No power...

Correction

- Completely insert Power Plug into an AC outlet.
- Set POWER button to on.
- Make sure power source is active.

Recording & Playback

TV program cannot be recorded...

Correction

- Check connections between VCR, external antenna, and TV.
- Check connections selection. (P.10,12,28)
- Make sure your antenna system (CABLE or TV) is correctly set. (Channels [P.16])
- Make sure cassette record tab is intact. (P.4)

Timer recording cannot be performed...

- Confirm that clock is set to current time and date.
- Make sure Cable/DSS box (if used) is left on and tuned to channel to be recorded.
- Set recording start/stop times correctly. (P.20)
- Make sure VCR POWER button is pressed off. (P.20)
- Timer recording may not be performed or continued if a power interruption occurs before or during a Timer Recording, even after power is restored.

There is no playback picture, or the playback picture is noisy or contains streaks...

- Select channel 3 or 4 on TV to match VCR output channel (3 or 4) (P.10) or select LINE.
- Set VCR/TV selector to "VCR."
- Adjust TRACKING control in either direction. (P.46)
- Try Head Cleaning. (P.45)

Special effects playback, picture may contain some vertical jitter when using a TV with an Automatic Vertical Hold Control...

- Set TV's Vertical Hold Control to MANUAL, then adjust.

VCR cannot be controlled...

- Make sure VCR power is on.
- Check Remote batteries.
- Make sure VCR LOCK is set to off. (P.40)
- Make sure Remote is in proper mode. (P.26)
- Make sure Timer Record is not in progress.

Remote Control

VCR cannot be remote controlled...

Correction

- Make sure VCR power is on.
- Make sure Remote is in VCR mode.
- Aim Remote Control directly at remote sensor on VCR. (P.6)
- Avoid any object blocking signal path.
- Check Remote batteries. (P.4)
- Make sure VCR LOCK is set to off. (P.40)
- Exposing VCR remote sensor to direct fluorescent or outdoor light may cause signal interference.

ACTION and PROG/VCR+ buttons do not respond...

- Check connections between VCR, external antenna, and TV.
- Press VCR button for VCR mode. (P.26)
- Check Remote batteries. (P.4)

Miscellaneous

Programs cannot be viewed on TV...

Correction

- Make sure TV power is on.
- Make sure TV is set to output of VCR.
- Check connections between VCR, external antenna, and TV.
- Set VCR/TV selector to "TV." (P.19)
- Make sure proper signal source is selected.

Video cassette cannot be inserted...

- Insert the cassette with window side up; record tab facing you.
- Check if a tape is already in the unit.

Video cassette cannot be removed...

- Completely insert Power Plug into an AC outlet.

Video cassette ejects when a recording is started or the power is turned off for timer recording...

- Make sure cassette record tab is intact. (P.4)
- To enable Quick play mechanism, the cylinder will rotate for about 3 minutes. This reduces response time from Stop to Play mode and from Play to Rewind Search mode.

In Stop mode, the motor (CYLINDER) continues to rotate...

If you cannot resolve the problem, please call the Customer Call Center for product assistance at 1-800-211-PANA (7262). To locate an authorized servicenter, please call toll free 1-800-211-PANA (7262) or send e-mail to : consumerproducts@panasonic.com

For Your Information

For Product Information, Operating Assistance, Literature Request, Dealer Locations, and all Customer Service inquiries please contact:

1-800-211-PANA (7262), Monday-Friday 9am-9pm Saturday-Sunday 9am-7pm, EST. or send e-mail to : consumerproducts@panasonic.com

Web Site: <http://www.panasonic.com>

You can purchase parts, accessories or locate your nearest servicer by visiting our Web Site.

Accessory Purchases:

Customer Orders Only 800-332-5368 (Customer Orders Only)
Panasonic Services Company 20421 84th Avenue South, Kent, WA 98032
(6 am to 5 pm Monday - Friday; 6 am to 10:30 am Saturday; PST)
(Visa, MasterCard, Discover Card, American Express, Check)

Factory Servicenters Locations

CALIFORNIA

6550 Katella Avenue
Cypress, CA 90630

800 Dubuque Avenue
S. San Francisco,
CA 94080

3878 Ruffin Road
Suite A
San Diego, CA 92123

COLORADO

1640 South Abilene
Street Suite D
Aurora, CO 80012

FLORIDA

3700 North 29th
Avenue
Suite 102
Hollywood, FL
33020

GEORGIA

8655 Roswell Road
Suite 100
Atlanta, GA 30350

ILLINOIS

9060 Golf Road
Niles, IL 60714

1703 North Randall
Road
Elgin, IL 60123
(Pick-up/Drop-off only)

MARYLAND

62 Mountain Road
Glen Burnie, MD
21061

MASSACHUSETTS

60 Glacier Drive
Suite G
Westwood, MA 02090

MINNESOTA

7850-12th Avenue
South
Airport Business Center
Bloomington, MN 55425

OHIO

2236 Waycross Road
Civic Center Plaza
Forest Park, OH 45240

PENNSYLVANIA

2221 Cabot Blvd. West
Suite B
Langhorne, PA 19047

TEXAS

13615 Welch Road
Suite 101
Farmers Branch,
TX 75244

WASHINGTON

20425-84th Avenue
South
Kent, WA 98032

HAWAII

99-859 Iwaiwa
Street
Aiea, Hawaii 96701
Phone (808)488-
1996
Fax (808)486-4369

Service in Puerto Rico

Matsushita Electric of Puerto Rico, Inc. Panasonic Sales Company/ Factory Servicer:
Ave. 65 de Infanteria, Km. 9.5, San Gabriel Industrial Park, Carolina, Puerto Rico 00985
Phone (787)750-4300 Fax (787)768-2910

As of January 2000

Panasonic Consumer Electronics Company,
Division of Matsushita Electric Corporation
of America, One Panasonic Way
Secaucus, New Jersey 07094

Panasonic Sales Company,
Division of Matsushita Electric of Puerto Rico, Inc.
AVE. 65 de Infantería, Km. 9.5 San Gabriel
Industrial Park Carolina, Puerto Rico 00985

PANASONIC Video Products Limited Warranty

Panasonic Consumer Electronics Company or Panasonic Sales Company (collectively referred to as "the Warrantor") will repair this product with new or refurbished parts, free of charge, in the USA or Puerto Rico, in the event of a defect in materials or workmanship as follows (all time periods commence from the date of the original purchase):

PRODUCT	PARTS	LABOR	SERVICE	CONTACT NUMBER
CAMCORDER	ONE (1) YEAR, EXCEPT CCD IMAGE SENSOR	NINETY (90) DAYS	Carry-In or Mail In	1-800-211-PANA(7262)
	CCD IMAGE SENSOR - SIX (6) MONTHS	NINETY (90) DAYS		
VCR	ONE (1) YEAR	NINETY (90) DAYS	Carry-In or Mail In	1-800-211-PANA(7262)
A/V MIXER	ONE (1) YEAR	NINETY (90) DAYS	Carry-In or Mail In	1-800-211-PANA(7262)
MONITOR- VCR Combination	ONE (1) YEAR, EXCEPT CRT CRT - TWO (2) YEARS	NINETY (90) DAYS CRT - NINETY (90) DAYS	Carry-In: 21" CRT and Smaller	1-800-211-PANA(7262)
			In-home or carry-in: 22" CRT and Larger	

Batteries (if included) - New rechargeable batteries in exchange for defective rechargeable batteries for ten (10) days. Non-rechargeable batteries are not warranted.

Tape (if included) - New video cassette tape in exchange for a defective video cassette tape for five (5) days. In-home, carry-in or mail-in service, as applicable, in the USA can be obtained during the warranty period by contacting a Panasonic Services Company (PASC) Factory Servicenter listed in the Service Directory. Or call toll free contact number listed above, to locate an authorized PASC Servicenter. Carry-in or mail-in service in Puerto Rico can be obtained during the warranty period by calling the Panasonic Sales Company telephone number listed in the Servicenter Directory.

This warranty is extended only to the original purchaser. A purchase receipt or other proof of the date of the original purchase is required before warranty service is rendered.

This warranty only covers failures due to defects in materials and workmanship which occur during normal use and does not cover normal maintenance, including, but not limited to, video and audio head cleaning. The warranty does not cover damage which occurs in shipment, or failures which are caused by products not supplied by the warrantor, or failures which result from accident, misuse, abuse, neglect, mishandling, misapplication, alteration, modification, faulty installation, set-up adjustments, improper antenna, inadequate signal pickup, maladjustment of consumer controls, improper operation, power line surge, improper voltage supply, lightning damage, commercial use such as hotel, office, restaurant, or other business or rental use of the product, or service by anyone other than a PASC Factory Servicenter or a PASC authorized Servicenter, or damage that is attributable to acts of God.

LIMITS AND EXCLUSIONS

There are no express warranties except as listed above.

THE WARRANTOR SHALL NOT BE LIABLE FOR INCIDENTAL OR CONSEQUENTIAL DAMAGES (INCLUDING, WITHOUT LIMITATION, DAMAGE TO RECORDING MEDIA) RESULTING FROM THE USE OF THIS PRODUCTS, OR ARISING OUT OF ANY BREACH OF THE WARRANTY.

ALL EXPRESS AND IMPLIED WARRANTIES, INCLUDING THE WARRANTIES OF MERCHANTABILITY AND FITNESS FOR PARTICULAR PURPOSE, ARE LIMITED TO THE APPLICABLE WARRANTY PERIOD SET FORTH ABOVE.

Some states do not allow the exclusion or limitation of incidental or consequential damages, or limitations on how long an implied warranty lasts, so the above exclusions or limitations may not apply to you.

This warranty gives you specific legal rights and you may also have other rights which vary from state to state. If a problem with this product develops during or after the warranty period, you may contact your dealer or Servicenter. If the problem is not handled to your satisfaction, then write to the Consumer Affairs Department at the Panasonic Consumer Electronics Company address above.

SERVICE CALLS WHICH DO NOT INVOLVE DEFECTIVE MATERIALS OR WORKMANSHIP AS DETERMINED BY THE WARRANTOR, IN ITS SOLE DISCRETION, ARE NOT COVERED.

COSTS OF SUCH SERVICE CALLS ARE THE RESPONSIBILITY OF THE PURCHASER.

warvid 8/8/2000

For Your
Information

Como realizar la Configuración Inicial (VCR-TV)

1 Encienda el TV y ajústelo al canal 3.

2 Al encender el VCR con el control remoto.
Al encender el VCR por primera vez, en la pantalla aparecerá **SELECT LANGUAGE**.

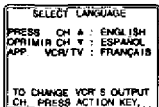
3  **Presione CH ▲** para seleccionar Inglés.
Presione CH ▼ para seleccionar Español.
Presione VCR/TV para seleccionar Francés.

- Si la pantalla no aparece, verifique las conexiones entre el VCR y el TV, y si el TV está sintonizado al canal 3, intente cambiándolo al canal 4.
- Cuando desee cambiar el canal de salida del VCR, por favor remítase Canal de Salida del VCR en la página 17.
- Si ajusta el idioma equivocado, realice los pasos de "Reajuste de Todas las Funciones de Memoria del VCR" en la página 11.

4  **Presione ▲▼** para seleccionar la conexión VCR ► TV y luego **presione ►** para ajustar.

5  **Presione CH ▲** para comenzar la operación de Ajuste Automático Canal/Reloj.

Caso: La conexión "CABLE/DSS ► VCR ► TV"

- Encienda la caja de cable y ajuste su canal de Estación Pública de Radiodifusión (PBS) en su uso horario.
- Si utiliza un receptor DSS, este tiene que estar apagado.

6 El ajuste Canal/Reloj se lleva a cabo automáticamente.

Caso 1
(Configuración completada)

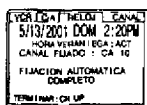

Presione CH ▲
para salir.

Caso 2
(Configuración incompleta)

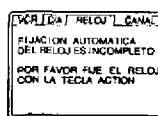

Presione ACTION para visualizar la pantalla del menú **RELOJ**.

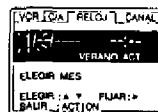

Presione ▲▼ para seleccionar el mes y ► para ajustar. De la misma forma, seleccione y ajuste la fecha, año, hora y DST (Hora de Verano).

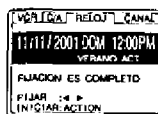

Presione dos veces ACTION para poner el **RELOJ** en marcha y salir.

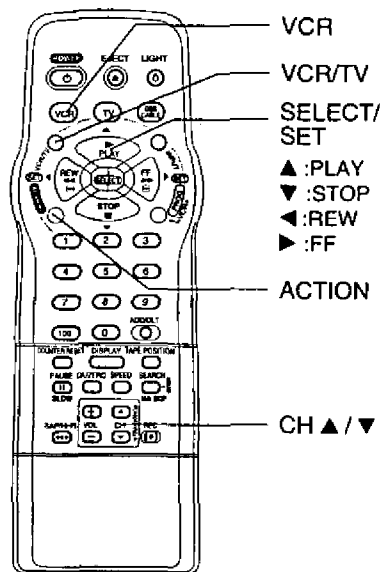

Como realizar la Configuración Inicial (CABLE/DSS-VCR-TV)

1 Encienda el TV y ajústelo al canal 3.

2 Al encender el VCR con el control remoto. Al encender el VCR por primera vez, en la pantalla aparecerá SELECT LANGUAGE.

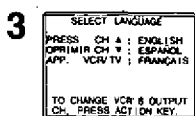

Presione CH ▲ para seleccionar Inglés.

Presione CH ▼ para seleccionar Español.

Presione VCR/TV para seleccionar Francés.

- Si la pantalla no aparece, verifique las conexiones entre el VCR y el TV, y si el TV está sintonizado al canal 3, intente cambiándolo al canal 4.
- Cuando desee cambiar el canal de salida del VCR, por favor remítase Canal de Salida del VCR en la página 17.
- Si ajusta el idioma equivocado, realice los pasos de "Reajuste de Todas las Funciones de Memoria del VCR" en la página 11.

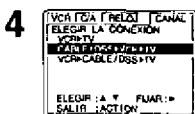

Presione ▲▼ para seleccionar la conexión CABLE/DSS►VCR►TV y luego.

Presione ► para ajustar.

5 Confirme el canal de salida de su caja de cable o receptor DSS.

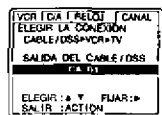

Presione ▲▼ para seleccionar el canal de salida de su caja de TV por cable o receptor DSS.

Presione ► para fijar.

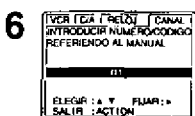

Presione ▲▼ para seleccionar el número de código de la caja de TV por cable o receptor DSS. (Consulte la lista de la página 9.)

Presione ► para fijar.

- Luego, vaya al paso 5 en la página 52.
- Si su caja de TV por cable o su receptor DSS no tiene un control remoto, elija "SIN CONTROL REMOTO"

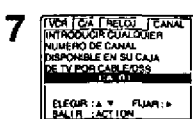

Presione ▲▼ para seleccionar un canal disponible en su caja de TV por cable o receptor DSS.

Presione ► para fijar.

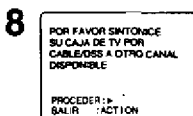

Sintonizar la TV por cable o el canal receptor DSS.

Presione ► para fijar.

"ESTA TRANSMITIENDO" aparece.

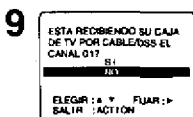

Presione ▲▼ para elegir "SI" o "NO".

Presione ► para fijar.

Si ud, usa una caja de TV por cable y ha elegido "SI", siga al paso 10.

Si ud, usa un receptor DSS y ha elegido "SI", siga al paso 5 en la página 52.

Si ha elegido "NO", aparecerá de nuevo la pantalla del paso 6. Intente fijar un código diferente para su marca y/o cambie le conexión de su equipo.

Si su respuesta es todavía "NO", el control de la caja de TV por cable o el receptor DSS no es disponible.

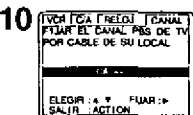

Verifique que su caja de TV por cable esté encendido y su receptor DSS esté apagado.

Presione ▲▼ para seleccionar el canal PBS de su local.

Presione ► para fijar.



Presione CH ▲ para iniciar la fijación automática del reloj.

- "FUJACION AUTOMATICA DE RELOJ EN PROCESO" aparece.

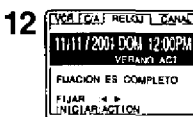

Comprobar si la hora está fijada correctamente.

Presione CH ▲ para terminar la fijación.

Si la hora que aparece no es correcta...

Si utiliza la caja de TV por cable y recibe más de una emisora PBS, intente nuevamente el ajuste automático del reloj donde antes no hubiera probado.

Si la hora no se puede ajustar automáticamente siga los pasos "Ajustar de nuevo el reloj" como demuestra más abajo.

Si aparece la pantalla inferior...

La instalación automática del reloj no es de aplicación para su zona horaria. Presione ACTION para que aparezca la pantalla "Fijación Manual del Reloj" y siga las paso 6 (caso 2) de la página 52.

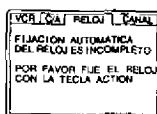

Nota

La fijación automática de la hora se efectuará cada día al apagar la videograbadora por primera vez. Por eso, la caja de TV por cable debe permanecer encendido y sintonizado al canal PBS cuando la videograbadora se apaga.

Ajustar de nuevo el reloj

1 Presione ACTION para exhibir el menú.



Presione ◀▶ para seleccionar "RELOJ".



Presione ▲▼ para seleccionar "MANUAL" y luego presione ▶.

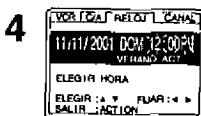

Presione ▲▼ y ◀▶ para seleccionar y ajustar la hora y la fecha.

5 Presione ACTION dos veces para que el reloj comience a funcionar y salir desde este modo.

Operaciones básicas para la reproducción

1 Inserte un cassette.

- la alimentación del VCR se activa. En la Pantalla de Visualización Multi Función se ilumina "VCR".

2 Presione PLAY para reproducir el cassette.

- Si el cassette no tiene lengüeta de prevención de grabación (página 4), se inicia la reproducción automáticamente.

Detalles especiales durante la grabación

- Presione FF o REW para búsqueda de escenas hacia delante/ hacia atrás. Presione de nuevo o presione PLAY para liberar.
- Presione PAUSE/SLOW para imagen Fija (Congelada). Presione PLAY para liberar.
- Presione PAUSE/SLOW en el modo de Imagen fija para imágenes cuadro a cuadro. Presione PLAY para liberar.
- Mantenga presionado PAUSE/SLOW en el modo de imagen fija para imágenes en cámara lenta. Presione PLAY para liberar.

3 Presione STOP para detener el cassette.

- Presione REW o FF en el modo de parada para rebobinado/avance rápido del cassette.
- Presione EJECT en el control remoto, o STOP/EJECT en el VCR para expulsar el cassette.

Operaciones básicas para la grabación

- 1** Inserte el cassette con lengüeta de protección de grabación (pág. 4).
- La alimentación del VCR se activa. En la pantalla Multi Función se ilumina "VCR".

- 2** Presione CH ▲▼, o las teclas de números para seleccionar el canal.

- 3** Presione SPEED para seleccionar la velocidad de grabación (pág.4)

- SP = Reproducción estándar,
- LP = Larga duración,
- SLP = Superlarga duración.

- 4** Presione REC para comenzar a grabar.

- Para eliminar escenas indeseadas, presione PAUSE/SLOW para pausar, y al presionar nuevamente se reanuda la grabación.
- No podrá ver otro canal durante la grabación.

- 5** Presione STOP para detener la grabación.

■ Grabación de un toque (grabar en marcha),

- El VCR se apaga después de ajustar la extensión de la grabación.
- > Cada vez que se presiona REC se añaden 30 min. a la extensión de grabación hasta un máximo de 4 horas.

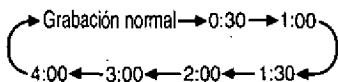

Programación fácil para la grabación con temporizador

- 1** Presione PROG/VCR+ para visualizar PROGRAM.

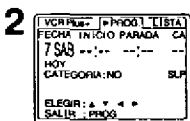

- Presione ◀▶ para visualizar la pantalla de Programación.



- 1) Para ajustar la FECHA de grabación, presione ▲▼ para seleccionar:**
 1-31 = una vez, o
 DIARIO = a la misma hora de lunes a viernes, o
 SEMANA = a la misma hora cada semana y
 presione ▶ para ajustar.

Orden para elegir

Ejemplo

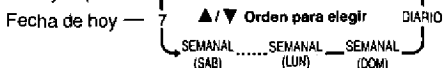

- 2) Para ajustar los ítems que quedan,**

- presione ▲▼ para seleccionar y
 presione ▶ para ajustar los tiempos de INICIO/PARADA, CANAL, o entrada de LÍNEA (pág. 44), CATEGORIA*, y velocidad de el cassette (SP, LP, SLP).

* Categoría
 NO, DEPORTE, CINE, COMEDIA, MUSICA, DRAMA

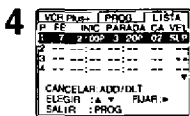

- Presione ▲▼ para seleccionar un número que no está usando para ingresar mas programas y
 presione ▶ para ajustar. Luego repita el paso 3.
 Presione nuevamente PROG/VCR+ para salir.

- 5** Presione POWER off para ajustar el temporizador.

(Se ilumina "TIMER" en el panel delantero)

Index

A			
Accessories	4		
AC Power Plug	7		
Add or Delete a Channel	17		
Audio Input Connector (L/R)	7		
Audio Output Connector (L/R)	7		
Auto Operation Functions	35		
Auto Shut-Off	40		
Auto VCR Plus+ System Channel Setup ...	22, 23		
B			
Before Requesting Service	49		
Blank Tape/ No Video Signal Indication	47		
C			
Cable Box Setup	12 ~ 15		
Cassette Compartment	6		
Channel Caption	36, 37		
Channel Up/Down (Tracking/V-Lock) Button	6		
Cleaning the VCR	45		
Clock/ Status/ Channel/ Speed Display	7		
CNR/ ANR	46		
Commercial Advance	30 ~ 32		
Connections	8, 10, 12		
Copying Your Tapes	44		
D			
DST (Daylight Saving Time)	17		
F			
Fast Forward/Search Button	6		
Features for a Quality Picture	46		
Function & Channel Display	47		
H			
Head Cleaning	45		
Hi-Fi Indicator	7		
I			
Index Search	34		
Initial Setup	8 ~ 15		
L			
Limited Warranty	51		
M			
Manual VCR Plus+ System Channel Setup	24		
Movie Advance	33		
MTS Broadcast	29		
Multi-Brand Control	26, 27		
O			
On-Screen Display	47, 48		
P			
Playback	18		
Play Button	6		
Power Button	6		
Power Indicator	7		
Program End Search	34		
R			
Record	19		
Record Button	6		
Remote Control Buttons	6		
Remote Sensor	6		
Remote Warning ON/OFF	41		
Repeat Play	35		
Review, Replace or Clear Program Contents	21		
Rewind/Search Button	6		
S			
Select Audio Mode	29		
Service Center List	50		
Spanish Quick Use Guide	52 ~ 55		
Specifications	46		
Stereo/ SAP/ Mono Broadcast	29		
Stop/Eject Button	6		
Super(S) VHS System	42, 43		
T			
Tape Position and Tape Status	39		
Time Stamp	38		
Timer Indicator	7		
Timer Recording	20, 21		
V			
VCR Indicator	7		
VCR Lock	40		
VCR Plus+ System Programming	25		
VCR Status & Clock Display	47		
VCR/TV Selector	6		
VHF/UHF Antenna Input Terminal	7		
VHF/UHF Antenna Output Terminal	7		
Video Input Connector (L/R)	7		
Video Output Connector (L/R)	7		
W			
Warning and Instruction Displays	48		
Weak Signal Display ON/OFF	41		
Z			
Zero Search	35		

