

Owner's Manual



LAWN TRACTOR

22.0 HP, 42" Mower

Electric Start

Automatic Transmission

Model No.

917.272282

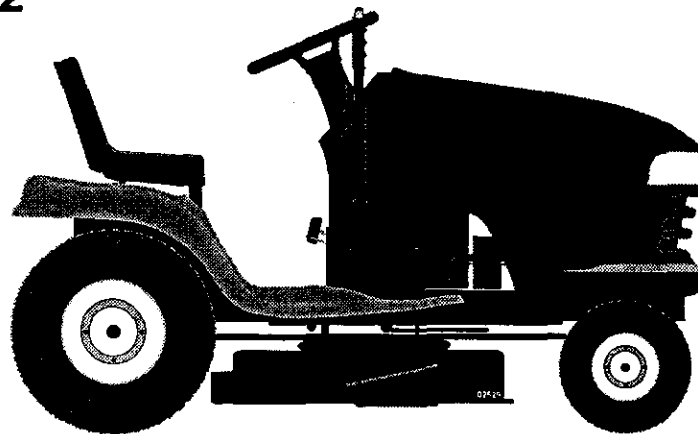

This product has a low emission engine which operates differently from previously built engines. Before you start the engine, read and understand this Owner's Manual.

IMPORTANT:

Read and follow all Safety Rules and Instructions before operating this equipment.

For answers to your questions about this product, Call:

1-800-659-5917

Sears Craftsman Help Line
5 am - 5 pm, Mon - Sat

Sears, Roebuck and Co., Hoffman Estates, IL 60179 U.S.A

Visit our Craftsman website: www.sears.com/craftsman

TABLE OF CONTENTS

Warranty	2	Maintenance Schedule	17
Safety Rules	3	Service and Adjustments	21
Product Specifications	6	Storage	28
Assembly/Pre-Operation	7	Troubleshooting	29
Operation	10	Repair Parts	34
Maintenance	17	Sears Service	Back Cover

WARRANTY

LIMITED WARRANTY ON CRAFTSMAN RIDING EQUIPMENT

For two (2) years from the date of purchase, if this Craftsman Riding Equipment is maintained, lubricated and tuned up according to the instructions in the owner's manual, Sears will repair or replace free of charge any parts that are found to be defective in material or workmanship according to the guidelines of coverage listed below. Sears will also provide free labor for these applicable warranted parts for the two full years. During the first 30 days of purchase, there will be no charges to service the product at your home for issues covered by this warranty. (See exclusions below). For your convenience, IN HOME warranty service will still be available after the first 30 days of purchase, but a trip charge will apply. This charge will be waived if the Craftsman product is dropped off at an authorized Sears location. For the nearest authorized Sears location, please call 1-800-4-MY-HOME®. This warranty applies only while this product is within the United States.

This Warranty does not cover:

- Expendable items which become worn during normal use, including but not limited to blades, spark plugs, air cleaners, belts, and oil filters.
- Standard Maintenance Servicing, oil changes, or tune-ups
- Tire replacement or repair caused by punctures from outside objects, such as nails, thorns, stumps, or glass.
- Repairs necessary because of operator abuse, including but not limited to, damage caused by towing objects beyond the capability of the riding equipment, impacting objects that bend the frame or crankshaft, or over-speeding the engine.
- Repairs necessary because of operator negligence, including but not limited to, electrical and mechanical damage caused by improper storage, failure to use the proper grade and amount of engine oil, failure to keep the deck clear of flammable debris, or failure to maintain the equipment according to the instructions contained in the owner's manual.
- Engine (fuel system) cleaning or repairs caused by fuel determined to be contaminated or oxidized (stale). In general, fuel should be used within 30 days of its purchase date.
- Normal deterioration and wear of the exterior finishes, or product label replacement.
- Riding equipment used for commercial or rental purposes.

LIMITED WARRANTY ON BATTERY

For ninety (90) days from date of purchase, if any battery included with this riding equipment proves defective in material or workmanship and our testing determines the battery will not hold a charge, Sears will replace the battery at no charge. During the first 30 days of purchase, there will be no charges to replace the battery at your HOME. After the first 30 days, for your convenience, IN-HOME warranty service will still be available but a trip charge will apply. This charge will be waived if the Craftsman product is dropped off at an authorized Sears location. For the nearest authorized Sears location, please call 1-800-4-MY-HOME®.

This battery warranty applies only while this product is within the United States.

This warranty gives you specific legal rights, and you may also have other rights, which vary, from state to state.

Sears, Roebuck and Co., Dept. 817WA, Hoffman Estates, IL 60179

SAFETY RULES

IMPORTANT: This cutting machine is capable of amputating hands and feet and throwing objects. Failure to observe the following safety instructions could result in serious injury or death.

⚠ WARNING: In order to prevent accidental starting when setting up, transporting, adjusting or making repairs, always disconnect spark plug wire and place wire where it cannot contact spark plug.

⚠ WARNING: Do not coast down a hill in neutral, you may lose control of the tractor.

⚠ WARNING: Tow only the attachments that are recommended by and comply with specifications of the manufacturer of your tractor. Use common sense when towing. Operate only at the lowest possible speed when on a slope. Too heavy of a load, while on a slope, is dangerous. Tires can lose traction with the ground and cause you to lose control of your tractor.

⚠ WARNING: Engine exhaust, some of its constituents, and certain vehicle components contain or emit chemicals known to the State of California to cause cancer and birth defects or other reproductive harm.

⚠ WARNING: Battery posts, terminals and related accessories contain lead and lead compounds, chemicals known to the State of California to cause cancer and birth defects or other reproductive harm. **Wash hands after handling.**

I. GENERAL OPERATION

- Read, understand, and follow all instructions in the manual and on the machine before starting.
- Only allow responsible adults, who are familiar with the instructions, to operate the machine.
- Clear the area of objects such as rocks, toys, wire, etc., which could be picked up and thrown by the blade.
- Be sure the area is clear of other people before mowing. Stop machine if anyone enters the area.
- Never carry passengers.

- Do not mow in reverse unless absolutely necessary. Always look down and behind before and while backing.
- Be aware of the mower discharge direction and do not point it at anyone. Do not operate the mower without either the entire grass catcher or the guard in place.
- Slow down before turning.
- Never leave a running machine unattended. Always turn off blades, set parking brake, stop engine, and remove keys before dismounting.
- Turn off blades when not mowing.
- Stop engine before removing grass catcher or unclogging chute.
- Mow only in daylight or good artificial light.
- Do not operate the machine while under the influence of alcohol or drugs.
- Watch for traffic when operating near or crossing roadways.
- Use extra care when loading or unloading the machine into a trailer or truck.
- Data indicates that operators, age 60 years and above, are involved in a large percentage of riding mower-related injuries. These operators should evaluate their ability to operate the riding mower safely enough to protect themselves and others from serious injury.
- Keep machine free of grass, leaves or other debris build-up which can touch hot exhaust / engine parts and burn. Do not allow the mower deck to plow leaves or other debris which can cause build-up to occur. Clean any oil or fuel spillage before operating or storing the machine. Allow machine to cool before storage.

II. SLOPE OPERATION

Slopes are a major factor related to loss-of-control and tipover accidents, which can result in severe injury or death. All slopes require extra caution. If you cannot back up the slope or if you feel uneasy on it, do not mow it.

SAFETY RULES

DO:

- Mow up and down slopes, not across.
- Remove obstacles such as rocks, tree limbs, etc.
- Watch for holes, ruts, or bumps. Uneven terrain could overturn the machine. *Tall grass can hide obstacles.*
- Use slow speed. Choose a low gear so that you will not have to stop or shift while on the slope.
- Follow the manufacturer's recommendations for wheel weights or counterweights to improve stability.
- Use extra care with grass catchers or other attachments. These can change the stability of the machine.
- Keep all movement on the slopes *slow* and *gradual*. Do not make sudden changes in speed or direction.
- Avoid starting or stopping on a slope. If tires lose traction, disengage the blades and proceed slowly *straight* down the slope.

DO NOT:

- *Do not* turn on slopes unless necessary, and then, turn slowly and gradually downhill, if possible.
- *Do not* mow near drop-offs, ditches, or embankments. The mower could suddenly turn over if a wheel is over the edge of a cliff or ditch, or if an edge caves in.
- *Do not* mow on wet grass. Reduced traction could cause sliding.
- *Do not* try to stabilize the machine by putting your foot on the ground.
- *Do not* use grass catcher on steep slopes.

III. CHILDREN

Tragic accidents can occur if the operator is not alert to the presence of children. Children are often attracted to the machine and the mowing activity. *Never* assume that children will remain where you last saw them.

- Keep children out of the mowing area and under the watchful care of another responsible adult.
- Be alert and turn machine off if children enter the area.
- Before and when backing, look behind and *down* for small children.

- Never carry children. They may fall off and be seriously injured or interfere with safe machine operation.
- Never allow children to operate the machine.
- Use extra care when approaching blind corners, shrubs, trees, or other objects that may obscure vision.

IV. SERVICE

- Use extra care in handling gasoline and other fuels. They are flammable and vapors are explosive.
 - Use only an approved container.
 - Never remove gas cap or add fuel with the engine running. Allow engine to cool before refueling. Do not smoke.
 - Never refuel the machine indoors.
 - Never store the machine or fuel container inside where there is an open flame, such as a water heater.
- Never run a machine inside a closed area.
- Keep nuts and bolts, especially blade attachment bolts, tight and keep equipment in good condition.
- Never tamper with safety devices. Check their proper operation regularly.
- Keep machine free of grass, leaves, or other debris build-up. Clean oil or fuel spillage. Allow machine to cool before storing.
- Stop and inspect the equipment if you strike an object. Repair, if necessary, before restarting.
- Never make adjustments or repairs with the engine running.
- Grass catcher components are subject to wear, damage, and deterioration, which could expose moving parts or allow objects to be thrown. Frequently check components and replace with manufacturer's recommended parts, when necessary.
- Mower blades are sharp and can cut. Wrap the blade(s) or wear gloves, and use extra caution when servicing them.
- Check brake operation frequently. Adjust and service as required.

SAFETY RULES

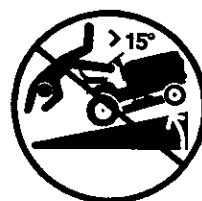

- Be sure the area is clear of other people before mowing. Stop machine if anyone enters the area.
- Never carry passengers or children even with the blades off.
- Do not mow in reverse unless absolutely necessary. Always look down and behind before and while backing.
- Never carry children. They may fall off and be seriously injured or interfere with safe machine operation.
- Keep children out of the mowing area and under the watchful care of another responsible adult.
- Be alert and turn machine off if children enter the area.
- Before and when backing, look behind and down for small children.
- Mow up and down slopes (15° Max), not across.
- Remove obstacles such as rocks, tree limbs, etc.
- Watch for holes, ruts, or bumps. Uneven terrain could overturn the machine. Tall grass can hide obstacles.
- Use slow speed. Choose a low gear so that you will not have to stop or shift while on the slope.
- Avoid starting or stopping on a slope. If tires lose traction, disengage the blades and proceed slowly straight down the slope.
- If machine stops while going uphill, disengage blades, shift into reverse and back down slowly.
- Do not turn on slopes unless necessary, and then, turn slowly and gradually downhill, if possible.

PRODUCT SPECIFICATIONS

Gasoline Capacity and Type:	4 Gallons Unleaded Regular
Oil Type (API-SF-SJ):	SAE 30 (Above 32°F) SAE 5W-30 (Below 32°F)
Oil Capacity:	4.0 Pints
Spark Plug: (GAP: .040")	Champion RC12YC
Ground Speed (MPH):	Forward: 5.5 Reverse: 2.4
Tire Pressure:	Front: 14 PSI Rear: 10- PSI
Charging System:	16 Amps @ 3600 RPM
Battery:	Amp/Hr: 28 Min. CCA: 230 Case Size: U1R
Blade Bolt Torque:	27-35 Ft. Lbs.

CONGRATULATIONS on your purchase of a new tractor. It has been designed, engineered and manufactured to give you the best possible dependability and performance. Should you experience any problem you cannot easily remedy, please contact a Sears or other qualified service center. We have competent, well-trained technicians and the proper tools to service or repair this tractor.

Please read and retain this manual. The instructions will enable you to assemble and maintain your tractor properly. Always observe the "SAFETY RULES".

REPAIR AGREEMENT

A Repair Agreement is available on this product. Contact your nearest Sears store for details.

CUSTOMER RESPONSIBILITIES

- Read and observe the safety rules.
- Follow a regular schedule in maintaining, caring for and using your tractor.
- Follow the instructions under "Maintenance" and "Storage" sections of this owner's manual.

! WARNING: This tractor is equipped with an internal combustion engine and should not be used on or near any unimproved forest-covered, brush-covered or grass-covered land unless the engine's exhaust system is equipped with a spark arrester meeting applicable local or state laws (if any). If a spark arrester is used, it should be maintained in effective working order by the operator. In the state of California the above is required by law (Section 4442 of the California Public Resources Code). Other states may have similar laws. Federal laws apply on federal lands. A spark arrester for the muffler is available through your nearest Sears service center (See REPAIR PARTS section of this manual).

UNASSEMBLED PARTS

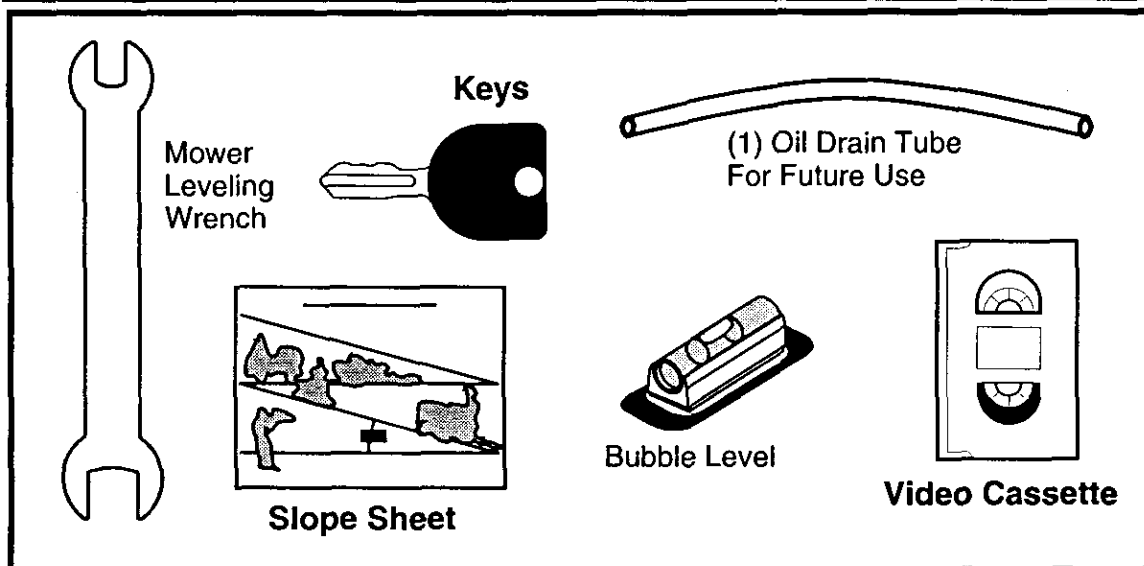

ASSEMBLY/PRE-OPERATION

Your new tractor has been assembled at the factory. Review the video cassette before you begin.

When right or left hand is mentioned in this manual, it means, from your point of view, when you are in the operating position (seated behind the steering wheel).

TO REMOVE TRACTOR FROM CARTON

UNPACK CARTON

1. Remove all accessible loose parts and parts boxes from carton.
2. Cut, from top to bottom, along lines on all four corners of carton, and lay panels flat.
3. Check for any additional loose parts or cartons and remove.

IMPORTANT: Check for and remove any staples in skid that may puncture tires where tractor is to roll off skid.

CHECK BATTERY

1. Lift hood to raised position.
- NOTE:** If this battery is put into service after month and year indicated on label (label located between terminals) charge battery for minimum of one hour at 6-10 amps. (See "BATTERY" in Maintenance section of this manual for charging instructions).

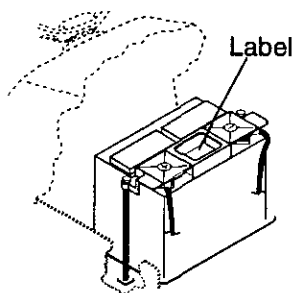

ADJUST SEAT

1. Raise seat and loosen adjustment knobs.
2. Lower seat into operating position and sit in seat.
3. Slide seat until a comfortable position is reached which allows you to press clutch/brake pedal all the way down.
4. Get off seat without moving its adjusted position.
5. Raise seat and tighten adjustment knob securely.

NOTE: You may now roll or drive your tractor off the skid. Follow the appropriate instruction below to remove the tractor from the skid.

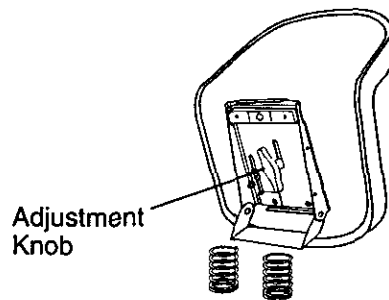

TO ROLL TRACTOR OFF SKID (See Operation section for location and function of controls)

1. Press lift lever plunger and raise attachment lift lever to its highest position.
2. Release parking brake by depressing brake pedal.
3. Place freewheel control in disengaged position to disengage transmission (See "TO TRANSPORT" in the Operation section of this manual).
4. Roll tractor forward off skid.
5. Remove banding holding the deflector shield up against tractor.

TO DRIVE TRACTOR OFF SKID (See Operation section for location and function of controls)

⚠ WARNING: Before starting, read, understand and follow all instructions in the Operation section of this manual. Be sure tractor is in a well-ventilated area. Be sure the area in front of tractor is clear of other people and objects.

1. Be sure all the above assembly steps have been completed.
 2. Check engine oil level and fill fuel tank with gasoline.
 3. Place freewheel control in "transmission engaged" position (see "TO TRANSPORT" in Operation section of this manual).
 4. Sit on seat in operating position, depress brake pedal and set the parking brake.
 5. Press lift lever plunger and raise attachment lift lever to its highest position.
 6. Start the engine. After engine has started, move throttle control to idle position.
 7. Release parking brake.
 8. Slowly depress forward drive pedal and drive tractor off skid.
 9. Apply brake to stop tractor and set parking brake.
 10. Turn ignition key to "STOP" position.
- Continue with the instructions that follow.

REPOSITION RIGHT REAR GAUGE WHEEL

For shipping purposes, the right rear gauge wheel assembly is mounted upside down on the mower. Remove the gauge wheel assembly and reinstall from the bottom as shown. To adjust gauge wheels, see the Operation section in this manual.

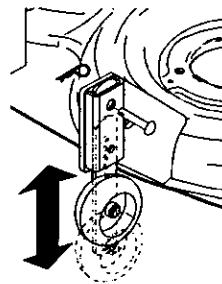

INSTALL MULCHER PLATE (If previously removed)

1. Raise and hold deflector shield in upright position.
2. Place front of mulcher plate over front of mower deck opening and slide into place, as shown.
3. Hook front latch into hole on front of mower deck.
4. Hook rear latch into hole on back of mower deck.

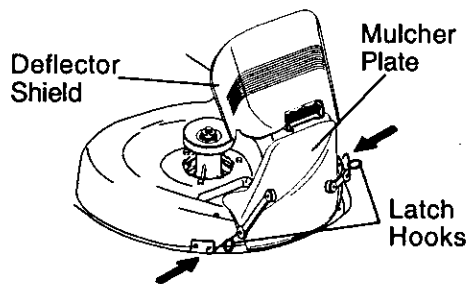

⚠ CAUTION: Do not remove deflector shield from mower. Raise and hold shield when attaching mulcher plate and allow it to rest on plate while in operation.

TO CONVERT TO BAGGING OR DISCHARGING

Simply remove mulcher plate and store in a safe place. Your mower is now ready for discharging or installation of optional grass catcher accessory.

NOTE: It is not necessary to change blades. The mulching blades are designed for discharging and bagging also.

CHECK TIRE PRESSURE

The tires on your tractor were overinflated at the factory for shipping purposes. Correct tire pressure is important for best cutting performance.

- Reduce tire pressure to PSI shown in "PRODUCT SPECIFICATIONS" section of this manual.

CHECK DECK LEVELNESS

For best cutting results, mower housing should be properly leveled. See "TO LEVEL MOWER HOUSING" in the Service and Adjustments section of this manual.

CHECK FOR PROPER POSITION OF ALL BELTS

See the figures that are shown for replacing motion and mower blade drive belts in the Service and Adjustments section of this manual. Verify that the belts are routed correctly.

CHECK BRAKE SYSTEM

After you learn how to operate your tractor, check to see that the brake is properly adjusted. See "TO ADJUST BRAKE" in the Service and Adjustments section of this manual.

✓CHECKLIST

Before you operate your new tractor, we wish to assure that you receive the best performance and satisfaction from this quality product.

Please review the following checklist:

- ✓ All assembly instructions have been completed.
- ✓ No remaining loose parts in carton.
- ✓ Battery is properly prepared and charged. (Minimum 1 hour at 6 amps).
- ✓ Seat is adjusted comfortably and tightened securely.
- ✓ All tires are properly inflated. (For shipping purposes, the tires were overinflated at the factory).
- ✓ Be sure mower deck is properly leveled side-to-side/front-to-rear for best cutting results. (Tires must be properly inflated for leveling).
- ✓ Check mower and drive belts. Be sure they are routed properly around pulleys and inside all belt keepers.
- ✓ Check wiring. See that all connections are still secure and wires are properly clamped.
- ✓ Before driving tractor, be sure free-wheel control is in "transmission engaged" position (see "TO TRANSPORT" in the Operation section of this manual).

While learning how to use your tractor, pay extra attention to the following important items:

- ✓ Engine oil is at proper level.
- ✓ Fuel tank is filled with fresh, clean, regular unleaded gasoline.
- ✓ Become familiar with all controls - their location and function. Operate them before you start the engine.
- ✓ Be sure brake system is in safe operating condition.
- ✓ It is important to purge the transmission before operating your tractor for the first time. Follow proper starting and transmission purging instructions (See "TO START ENGINE" and "PURGE TRANSMISSION" in the Operation section of this manual).

OPERATION

These symbols may appear on your tractor or in literature supplied with the product. Learn and understand their meaning.

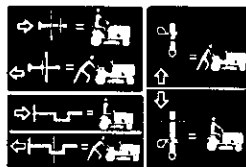
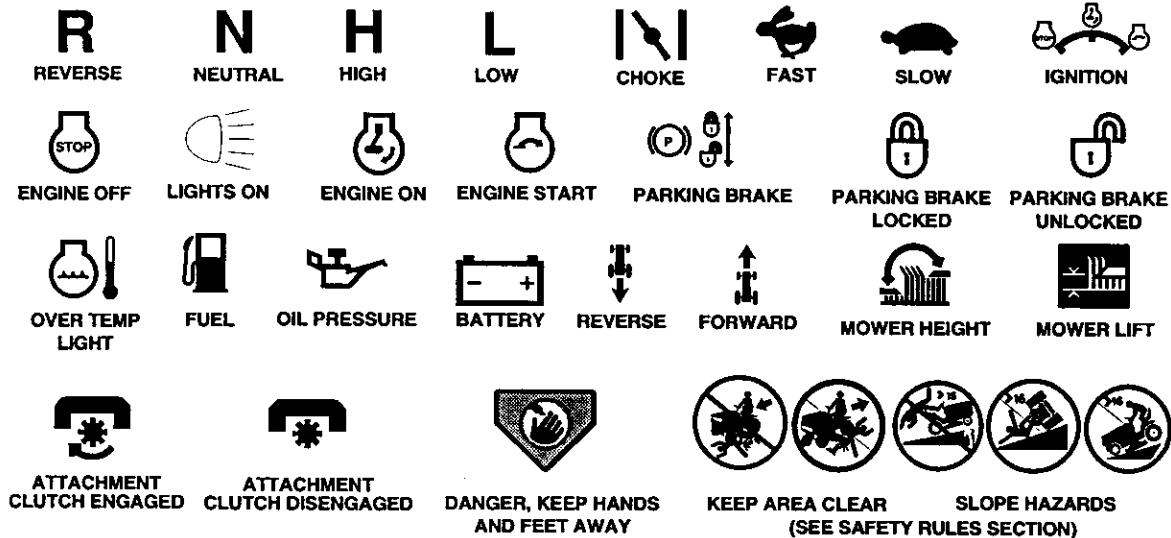

FREE WHEEL
(Automatic Models only)



Failure to follow instructions could result in serious injury or death. The safety alert symbol is used to identify safety information about hazards which can result in death, serious injury and/or property damage.



DANGER indicates a hazard which, if not avoided, will result in death or serious injury.



WARNING indicates a hazard which, if not avoided, could result in death or serious injury.



CAUTION indicates a hazard which, if not avoided, might result in minor or moderate injury.

CAUTION when used without the alert symbol, indicates a situation that could result in damage to the tractor and/or engine.



HOT SURFACES indicates a hazard which, if not avoided, could result in death, serious injury and/or property damage.



FIRE indicates a hazard which, if not avoided, could result in death, serious injury and/or property damage.

KNOW YOUR TRACTOR

READ THIS OWNER'S MANUAL AND SAFETY RULES BEFORE OPERATING YOUR TRACTOR

Compare the illustrations with your tractor to familiarize yourself with the locations of various controls and adjustments. Save this manual for future reference.

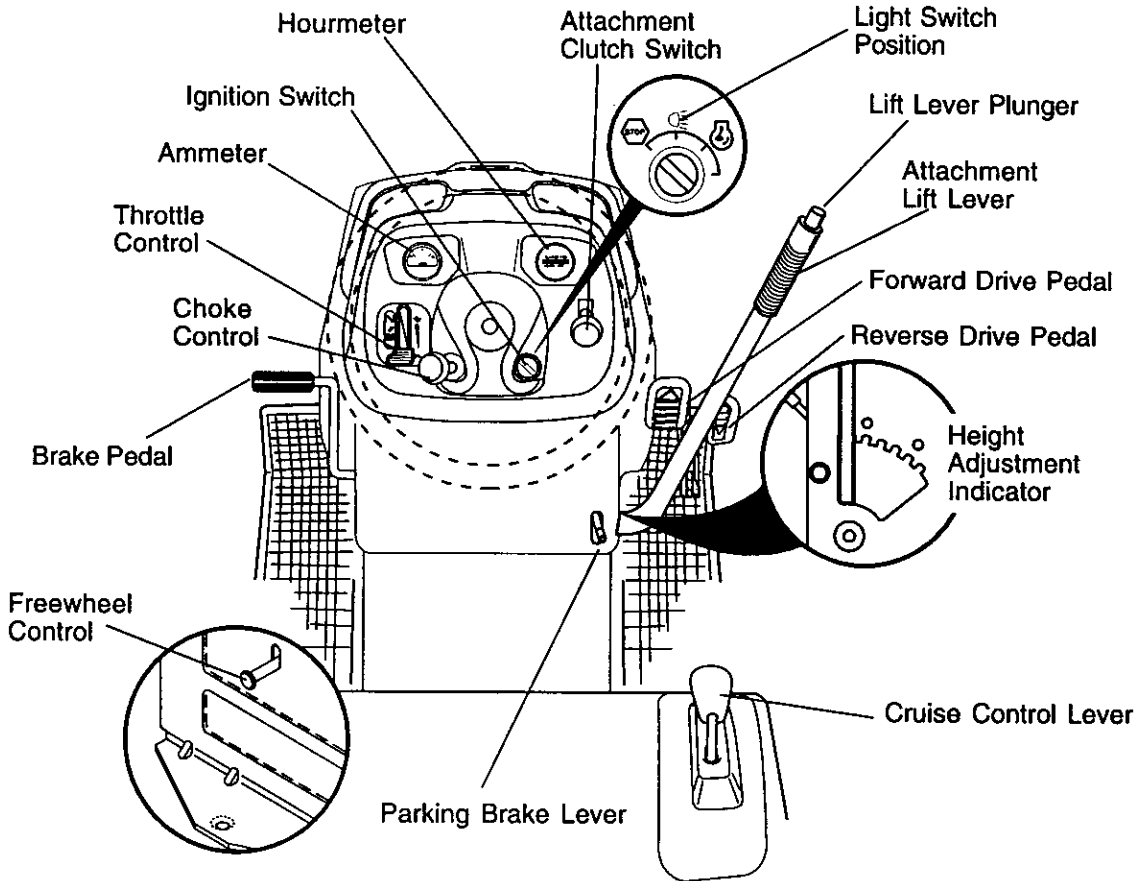

Our tractors conform to the safety standards of the American National Standards Institute.

AMMETER - Indicates charging (+) or discharging (-) of battery.

ATTACHMENT CLUTCH SWITCH - Used to engage the mower blades, or other attachments mounted to your tractor.

ATTACHMENT LIFT LEVER - Used to raise, lower, and adjust the mower deck or other attachments mounted to your tractor.

BRAKE PEDAL - Used for braking the tractor and starting the engine.

CRUISE CONTROL LEVER - Used to set forward movement of tractor at desired speed without holding the forward drive pedal.

FORWARD DRIVE PEDAL - Used for forward movement of tractor.

REVERSE DRIVE PEDAL - Used for reverse movement of tractor.

IGNITION SWITCH - Used for starting and stopping the engine.

LIFT LEVER PLUNGER - Used to release attachment lift lever when changing its position.

LIGHT SWITCH POSITION - Turns the headlights on and off.

PARKING BRAKE LEVER - Locks clutch/brake pedal into the brake position.

THROTTLE CONTROL - Used for controlling engine speed.

FREEWHEEL CONTROL - Disengages transmission for pushing or slowly towing the tractor with the engine off.

CHOKE CONTROL - Used for starting engine.

HOURMETER - Indicates hours of operation.



The operation of any tractor can result in foreign objects thrown into the eyes, which can result in severe eye damage. Always wear safety glasses or eye shields while operating your tractor or performing any adjustments or repairs. We recommend standard safety glasses or a wide vision safety mask worn over spectacles.

HOW TO USE YOUR TRACTOR TO SET PARKING BRAKE

Your tractor is equipped with an operator presence sensing switch. When engine is running, any attempt by the operator to leave the seat without first setting the parking brake will shut off the engine.

1. Depress brake pedal all the way down and hold.
2. Pull parking brake lever up and release pressure from brake pedal. Pedal should remain in brake position. Make sure parking brake will hold tractor secure.

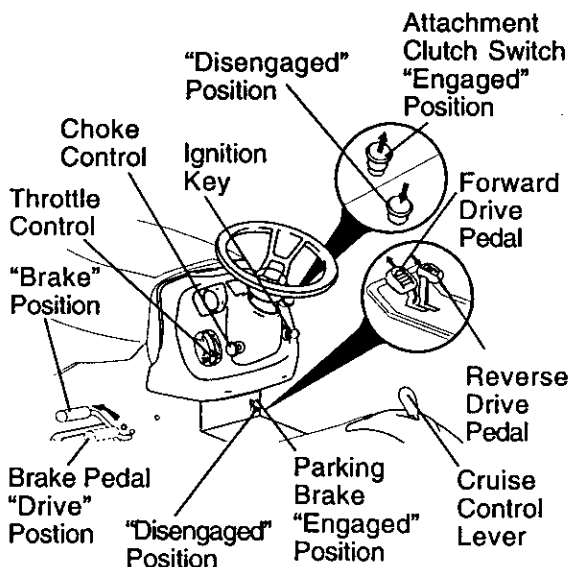

STOPPING

MOWER BLADES -

- To stop mower blades, push attachment clutch switch in to disengaged position.

GROUND DRIVE -

- To stop ground drive, depress brake pedal all the way down.

IMPORTANT: Forward and reverse drive pedals return to neutral position when not depressed.

ENGINE -

- Move throttle control to slow position.
- NOTE:** Failure to move throttle control to slow position to allow engine to idle before stopping may cause engine to "backfire".
- Turn ignition key to "STOP" position and remove key. Always remove key when leaving tractor to prevent unauthorized use.
- Never use choke to stop engine.

IMPORTANT: Leaving the ignition switch in any position other than "STOP" will cause the battery to discharge and go dead.

NOTE: Under certain conditions when tractor is standing idle with the engine running, hot engine exhaust gases may cause "browning" of grass. To eliminate this possibility, always stop engine when stopping tractor on grass areas.

CAUTION: Always stop tractor completely, as described above, before leaving the operator's position.

TO USE THROTTLE CONTROL

Always operate engine at full throttle.

- Operating engine at less than full throttle reduces the battery charging rate.
- Full throttle offers the best bagging and mower performance.

TO USE CHOKE CONTROL

Use choke control whenever you are starting a cold engine. Do not use to start a warm engine.

- To engage choke control, pull knob out. Slowly push knob in to disengage.

TO MOVE FORWARD AND BACKWARD

The direction and speed of movement is controlled by the forward and reverse drive pedals.

1. Start tractor and release parking brake.
2. Slowly depress forward or reverse drive pedal to begin movement. Ground speed increases the further down the pedal is depressed.

TO USE CRUISE CONTROL

The cruise control feature can be used for forward travel only.

1. With forward drive pedal depressed to desired speed, move cruise control lever forward to "SET" position and hold while lifting your foot off the pedal, then release the cruise control lever.

To disengage the cruise control, pull the lever backward to "OFF" position, or fully depress the brake pedal.

TO ADJUST MOWER CUTTING HEIGHT

The position of the attachment lift lever determines the cutting height.

- Grasp lift lever.
- Press plunger with thumb and move lever to desired position.

The cutting height range is approximately 1-1/2 to 4". The heights are measured from the ground to the blade tip with the engine not running. These heights are approximate and may vary depending upon soil conditions, height of grass and types of grass being mowed.

- The average lawn should be cut to approximately 2-1/2 inches during the cool season and to over 3 inches during hot months.

For healthier and better looking lawns, mow often and after moderate growth.

- For best cutting performance, grass over 6 inches in height should be mowed twice. Make the first cut relatively high; the second to desired height.

TO ADJUST GAUGE WHEELS

Gauge wheels are properly adjusted when they are slightly off the ground when mower is at the desired cutting height in operating position. Gauge wheels then keep the deck in proper position to help prevent scalping in most terrain conditions.

NOTE: Be sure tractor is on a flat level surface.

1. Lower mower and adjust mower to desired cutting height (See "TO ADJUST MOWER CUTTING HEIGHT" in this section of manual).
2. Remove retainer spring and clevis pin which secure each gauge wheel bar.
3. Lower gauge wheels to ground. Raise gauge wheels slightly to align holes in bracket and gauge wheel bar and insert clevis pin. Gauge wheels should be slightly off the ground.

4. Replace retainer spring into clevis pin.
5. Be sure all gauge wheels are in the same setting.

IMPORTANT: Be sure to readjust gauge wheels if you change the cutting height of the mower deck.

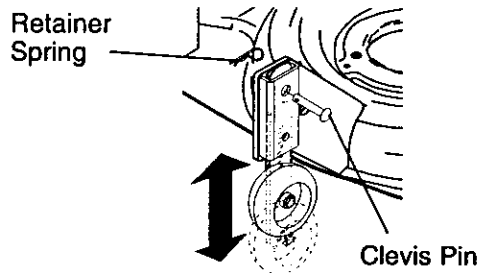

TO OPERATE MOWER

Your tractor is equipped with an operator presence sensing switch. Any attempt by the operator to leave the seat with the engine running and the attachment clutch engaged will shut off the engine.

1. Select desired height of cut.
2. Start mower blades by engaging attachment clutch control.

TO STOP MOWER BLADES - disengage attachment clutch control.

CAUTION: Do not operate the mower without either the entire grass catcher, on mowers so equipped, or the deflector shield in place.

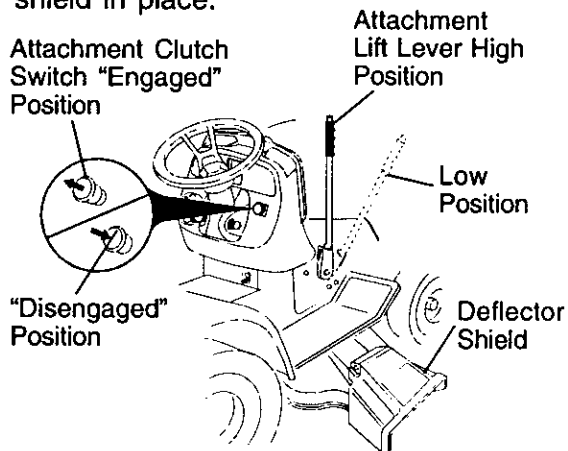

TO OPERATE ON HILLS

WARNING: Do not drive up or down hills with slopes greater than 15° and do not drive across any slope. Use the slope guide provided at the back of this manual.

- Choose the slowest speed before starting up or down hills.
- Avoid stopping or changing speed on hills.
- If stopping is absolutely necessary, push brake pedal quickly to brake position and engage parking brake.

- To restart movement, slowly release parking brake and brake pedal.
- Slowly depress appropriate drive pedal to slowest setting.
- Make all turns slowly.

TO TRANSPORT

When pushing or towing your tractor, be sure to disengage transmission by placing freewheel control in freewheeling position. Freewheel control is located at the rear drawbar of tractor.

1. Raise attachment lift to highest position with attachment lift control.
 2. Pull freewheel control out and down into the slot and release so it is held in the disengaged position.
- Do not push or tow tractor at more than two (2) MPH.
 - To re-engage transmission, reverse above procedure.

Transmission Engaged

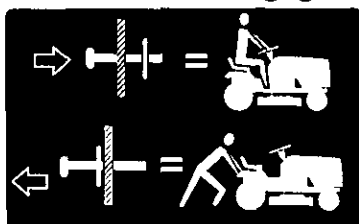

Transmission Disengaged

NOTE: To protect hood from damage when transporting your tractor on a truck or a trailer, be sure hood is closed and secured to tractor. Use an appropriate means of tying hood to tractor (rope, cord, etc.).

TOWING CARTS AND OTHER ATTACHMENTS

Tow only the attachments that are recommended by and comply with specifications of the manufacturer of your tractor. Use common sense when towing. Too heavy of a load, while on a slope, is dangerous. Tires can lose traction with the ground and cause you to lose control of your tractor.

BEFORE STARTING THE ENGINE CHECK ENGINE OIL LEVEL

The engine in your tractor has been shipped, from the factory, already filled with summer weight oil.

1. Check engine oil with tractor on level ground.
2. Remove oil fill cap/dipstick and wipe clean, reinsert the dipstick and screw cap tight, wait for a few seconds,

remove and read oil level. If necessary, add oil until "FULL" mark on dipstick is reached. Do not overfill.

- For cold weather operation you should change oil for easier starting ((See the oil viscosity chart in the Maintenance section of this manual).
- To change engine oil, see the Maintenance section in this manual.

ADD GASOLINE

- Fill fuel tank to bottom of tank filler neck. Do not overfill. Use fresh, clean, regular unleaded gasoline with a minimum of 87 octane. (Use of leaded gasoline will increase carbon and lead oxide deposits and reduce valve life). Do not mix oil with gasoline. Purchase fuel in quantities that can be used within 30 days to assure fuel freshness.

CAUTION: Wipe off any spilled oil or fuel. Do not store, spill or use gasoline near an open flame.

IMPORTANT: When operating in temperatures below 32°F(0°C), use fresh, clean winter grade gasoline to help insure good cold weather starting.

CAUTION: Alcohol blended fuels (called gasohol or using ethanol or methanol) can attract moisture which leads to separation and formation of acids during storage. Acidic gas can damage the fuel system of an engine while in storage. To avoid engine problems, the fuel system should be emptied before storage of 30 days or longer. Drain the gas tank, start the engine and let it run until the fuel lines and carburetor are empty. Use fresh fuel next season. See Storage Instructions for additional information. Never use engine or carburetor cleaner products in the fuel tank or permanent damage may occur.

TO START ENGINE

When starting the engine for the first time or if the engine has run out of fuel, it will take extra cranking time to move fuel from the tank to the engine.

1. Be sure freewheel control is in the transmission engaged position.
2. Sit on seat in operating position, depress brake pedal and set parking brake.
3. Move attachment clutch to disengaged position.
4. Move throttle control to fast position
5. Pull choke control out for a cold engine start attempt. For a warm engine start attempt the choke control may not be needed.

NOTE: Before starting, read the warm and cold starting procedures below.

6. Insert key into ignition and turn key clockwise to start position and release key as soon as engine starts. Do not run starter continuously for more than fifteen seconds per minute. If the engine does not start after several attempts, push choke control in, wait a few minutes and try again. If engine still does not start, pull the choke control out and retry.

WARM WEATHER STARTING (50° F and above)

7. When engine starts, slowly push choke control in until the engine begins to run smoothly. If the engine starts to run roughly, pull the choke control out slightly for a few seconds and then continue to push the control in slowly.
- The attachments and ground drive can now be used. If the engine does not accept the load, restart the engine and allow it to warm up for one minute using the choke as described above.

COLD WEATHER STARTING (50° F and below)

7. When engine starts, slowly push choke control in until the engine begins to run smoothly. Continue to push the choke control in small steps allowing the engine to accept small changes in speed and load, until the choke control is fully in. If the engine starts to run roughly, pull the choke control out slightly for a few seconds and then continue to push the control in slowly. This may require an engine warm-up period from several seconds to several minutes, depending on the temperature.

AUTOMATIC TRANSMISSION WARM UP

Before driving the unit in cold weather, the transmission should be warmed up as follows:

1. Be sure the tractor is on level ground.
 2. Release the parking brake and let the brake slowly return to operating position.
 3. Allow one minute for transmission to warm up. This can be done during the engine warm up period.
- The attachments can be used during the engine warm-up period after the transmission has been warmed up and may require the choke control be pulled out slightly.

NOTE: If at a high altitude (above 3000 feet) or in cold temperatures (below 32 F) the carburetor fuel mixture may need to be adjusted for best engine performance (see "TO ADJUST CARBURETOR" in the Service and Adjustments section of this manual).

PURGE TRANSMISSION

CAUTION: Never engage or disengage freewheel lever while the engine is running.

To ensure proper operation and performance, it is recommended that the transmission be purged before operating tractor for the first time. This procedure will remove any trapped air inside the transmission which may have developed during shipping of your tractor.

IMPORTANT: Should your transmission require removal for service or replacement, it should be purged after reinstallation before operating the tractor.

1. Place tractor safely on level surface with engine off and parking brake set.
2. Disengage transmission by placing freewheel control in disengaged position (See "TO TRANSPORT" in this section of manual).
3. Sitting in the tractor seat, start engine. After the engine is running, move throttle control to slow position. Disengage parking brake.
4. Depress forward drive pedal to full forward position and hold for five (5) seconds and release pedal. Depress reverse drive pedal to full reverse position and hold for five (5) seconds and release pedal. Repeat this procedure three (3) times.

NOTE: During this step there will be no movement of drive wheels. The air is being removed from hydraulic drive system.

5. Shutoff engine and set parking brake.
6. Engage transmission by placing freewheel control in engaged position (See "TO TRANSPORT" in this section of manual).
7. Sitting in the tractor seat, start engine. After the engine is running, move throttle control to half (1/2) speed. Disengage parking brake.
8. Drive tractor forward for approximately five feet then backwards for five feet. Repeat this driving procedure three times.

Your transmission is now purged and now ready for normal operation.

MOWING TIPS

- Mower should be properly leveled for best mowing performance. See "TO LEVEL MOWER HOUSING" in the Service and Adjustments section of this manual.
- The left hand side of mower should be used for trimming.
- Drive so that clippings are discharged onto the area that has already been cut. Have the cut area to the right of the tractor. This will result in a more even distribution of clippings and more uniform cutting.
- When mowing large areas, start by turning to the right so that clippings will discharge away from shrubs, fences, driveways, etc. After one or two rounds, mow in the opposite direction making left hand turns until finished.

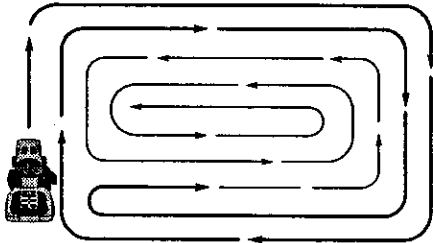

- If grass is extremely tall, it should be mowed twice to reduce load and possible fire hazard from dried clippings. Make first cut relatively high; the second to the desired height.
- Do not mow grass when it is wet. Wet grass will plug mower and leave undesirable clumps. Allow grass to dry before mowing.
- **Always operate engine at full throttle when mowing** to assure better mowing performance and proper discharge of material. Regulate ground speed by selecting a low enough gear to give the mower cutting performance as well as the quality of cut desired.
- When operating attachments, select a ground speed that will suit the terrain and give best performance of the attachment being used.

MULCHING MOWING TIPS

IMPORTANT: For best performance, keep mower housing free of built-up grass and trash. Clean after each use.

- The special mulching blade will recut the grass clippings many times and reduce them in size so that as they fall onto the lawn they will disperse into the grass and not be noticed. Also, the mulched grass will biodegrade quickly to provide nutrients for the lawn. Always mulch with your highest engine (blade) speed as this will provide the best recutting action of the blades.
- Avoid cutting your lawn when it is wet. Wet grass tends to form clumps and interferes with the mulching action. The best time to mow your lawn is the early afternoon. At this time the grass has dried and the newly cut area will not be exposed to the direct sun.
- For best results, adjust the mower cutting height so that the mower cuts off only the top one-third of the grass blades. For extremely heavy grass, reduce your width of cut on each pass and mow slowly.

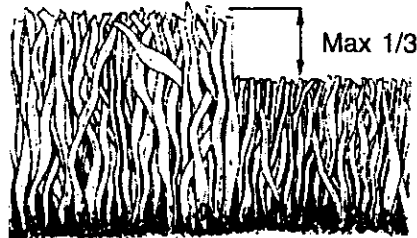

- Certain types of grass and grass conditions may require that an area be mulched a second time to completely hide the clippings. When doing a second cut, mow across or perpendicular to the first cut path.
- Change your cutting pattern from week to week. Mow north to south one week then change to east to west the next week. This will help prevent matting and graining of the lawn.

MAINTENANCE

MAINTENANCE SCHEDULE		BEFORE EACH USE					BEFORE STORAGE					
		EVERY 8 HOURS	EVERY 25 HOURS	EVERY 50 HOURS	EVERY 100 HOURS	EVERY SEASON	EVERY 8 HOURS	EVERY 25 HOURS	EVERY 50 HOURS	EVERY 100 HOURS	EVERY SEASON	
TRACTOR	Check Brake Operation	✓	✓									
	Check Tire Pressure	✓	✓									
	Check Operator Presence and Interlock Systems	✓										
	Check for Loose Fasteners	✓				✓ ⁵			✓			
	Sharpen/Replace Mower Blades			✓ ³								
	Lubrication Chart			✓					✓			
	Check Battery Level			✓ ⁴						✓		
	Clean Battery and Terminals			✓						✓		
	Check Transaxle Cooling			✓								
	Check V-Belts					✓						
ENGINE	Check Engine Oil Level	✓	✓									
	Change Engine Oil (with oil filter)				✓ ^{1,2}				✓			
	Change Engine Oil (without oil filter)			✓ ^{1,2}					✓			
	Clean Air Filter			✓ ²								
	Clean Air Screen			✓ ²								
	Inspect Muffler/Spark Arrester				✓							
	Replace Oil Filter (if equipped)					✓ ^{1,2}						
	Clean Engine Cooling Fins					✓ ²						
	Replace Spark Plug					✓			✓			
	Replace Air Filter Paper Cartridge					✓ ²						
Replace Fuel Filter									✓			

1 - Change more often when operating under a heavy load or in high ambient temperatures.
 2 - Service more often when operating in dirty or dusty conditions.

3 - Replace blades more often when mowing in sandy soil.
 4 - Not required if equipped with maintenance-free battery.
 5 - Tighten front axle pivot bolt to 35 ft.-lbs. maximum. Do not overtighten.

GENERAL RECOMMENDATIONS

The warranty on this tractor does not cover items that have been subjected to operator abuse or negligence. To receive full value from the warranty, operator must maintain tractor as instructed in this manual.

Some adjustments will need to be made periodically to properly maintain your tractor.

All adjustments in the Service and Adjustments section of this manual should be checked at least once each season.

- Once a year you should replace the spark plug, clean or replace air filter, and check blades and belts for wear. A new spark plug and clean air filter assure proper air-fuel mixture and help your engine run better and last longer.

BEFORE EACH USE

- Check engine oil level.
- Check brake operation.
- Check tire pressure.
- Check operator presence and interlock systems for proper operation.
- Check for loose fasteners.

LUBRICATION CHART

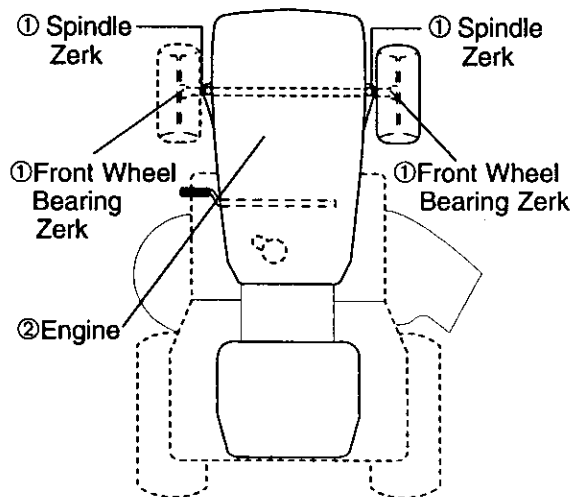

① General Purpose Grease
 ② REFER TO Maintenance "ENGINE" SECTION
IMPORTANT: Do not oil or grease the pivot points which have special nylon bearings. Viscous lubricants will attract dust and dirt that will shorten the life of the self-lubricating bearings. If you feel they must be lubricated, use only a dry, powdered graphite type lubricant sparingly.

TRACTOR

Always observe safety rules when performing any maintenance.

BRAKE OPERATION

If tractor requires more than six (6) feet stopping distance at high speed in highest gear, then brake must be adjusted. (See "TO ADJUST BRAKE" in the Service and Adjustments section of this manual).

TIRES

- Maintain proper air pressure in all tires (See "PRODUCT SPECIFICATIONS" section of this manual).
- Keep tires free of gasoline, oil, or insect control chemicals which can harm rubber.
- Avoid stumps, stones, deep ruts, sharp objects and other hazards that may cause tire damage.

NOTE: To seal tire punctures and prevent flat tires due to slow leaks, tire sealant may be purchased from your local parts dealer. Tire sealant also prevents tire dry rot and corrosion.

OPERATOR PRESENCE SYSTEM

Be sure operator presence and interlock systems are working properly. If your tractor does not function as described, repair the problem immediately.

- The engine should not start unless the brake pedal is fully depressed and attachment clutch control is in the disengaged position.
- When the engine is running, any attempt by the operator to leave the seat without first setting the parking brake should shut off the engine.
- When the engine is running and the attachment clutch is engaged, any attempt by the operator to leave the seat should shut off the engine.
- The attachment clutch should never operate unless the operator is in the seat.

BLADE CARE

For best results mower blades must be kept sharp. Replace bent or damaged blades.

BLADE REMOVAL

1. Raise mower to highest position to allow access to blades.
2. Remove blade bolt, lock washer and flat washer securing blade.
3. Install new or resharpened blade with trailing edge up towards deck as shown.

IMPORTANT: To ensure proper assembly, center hole in blade must align with star on mandrel assembly.

4. Reassemble blade bolt, lock washer and flat washer in exact order as shown.
5. Tighten blade bolt securely (27-35 Ft. Lbs. torque).

IMPORTANT: Blade bolt is grade 8 heat treated.

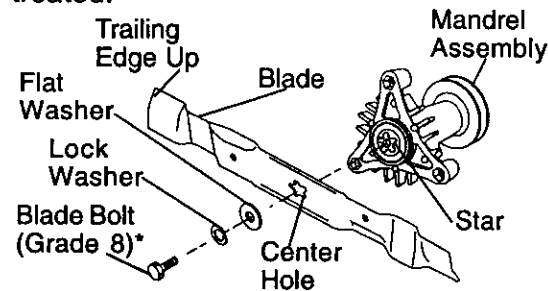

*A Grade 8 Heat Treated Bolt Can Be Identified By Six Lines On The Bolt Head

TO SHARPEN BLADE

NOTE: We do not recommend sharpening blade - but if you do, be sure the blade is balanced.

Care should be taken to keep the blade balanced. An unbalanced blade will cause excessive vibration and eventual damage to mower and engine.

- The blade can be sharpened with a file or on a grinding wheel. Do not attempt to sharpen while on the mower.
- To check blade balance, you will need a 5/8" diameter steel bolt, pin, or a cone balancer. (When using a cone balancer, follow the instructions supplied with balancer.)

NOTE: Do not use a nail for balancing blade. The lobes of the center hole may appear to be centered, but are not.

- Slide blade on to an unthreaded portion of the steel bolt or pin and hold the bolt or pin parallel with the ground. If blade is balanced, it should remain in a horizontal position. If either end of the blade moves downward, sharpen the heavy end until the blade is balanced.

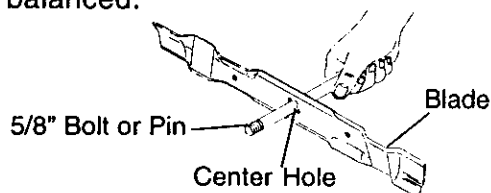

BATTERY

Your tractor has a battery charging system which is sufficient for normal use. However, periodic charging of the battery with an automotive charger will extend its life.

- Keep battery and terminals clean.
 - Keep battery bolts tight.
 - Keep small vent holes open.
 - Recharge at 6-10 amperes for 1 hour.
- NOTE:** The original equipment battery on your tractor is maintenance free. Do not attempt to open or remove caps or covers. Adding or checking level of electrolyte is not necessary.

TO CLEAN BATTERY AND TERMINALS
Corrosion and dirt on the battery and terminals can cause the battery to "leak" power.

1. Remove terminal guard.
2. Disconnect BLACK battery cable first then RED battery cable and remove battery from tractor.
3. Rinse the battery with plain water and dry.
4. Clean terminals and battery cable ends with wire brush until bright.
5. Coat terminals with grease or petroleum jelly.
6. Reinstall battery (See "REPLACING BATTERY" in the SERVICE AND ADJUSTMENTS section of this manual).

TRANSAXLE COOLING

The transmission fan and cooling fins should be kept clean to assure proper cooling.

Do not attempt to clean fan or transmission while engine is running or while the transmission is hot. To prevent possible damage to seals, do not use high pressure water or steam to clean transaxle.

- Inspect cooling fan to be sure fan blades are intact and clean.
- Inspect cooling fins for dirt, grass clippings and other materials. To prevent damage to seals, do not use compressed air or high pressure sprayer to clean cooling fins.

TRANSAXLE PUMP FLUID

The transaxle was sealed at the factory and fluid maintenance is not required for the life of the transaxle. Should the transaxle ever leak or require servicing, contact a Sears or other qualified service center.

V-BELTS

Check V-belts for deterioration and wear after 100 hours of operation and replace if necessary. The belts are not adjustable. Replace belts if they begin to slip from wear.

ENGINE LUBRICATION

Only use high quality detergent oil rated with API service classification SF-SJ. Select the oil's SAE viscosity grade according to your expected operating temperature.

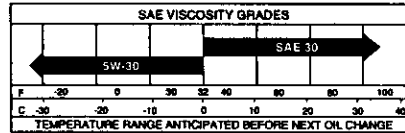

NOTE: Although multi-viscosity oils (5W30, 10W30 etc.) improve starting in cold weather, these multi-viscosity oils will result in increased oil consumption when used above 32°F. Check your engine oil level more frequently to avoid possible engine damage from running low on oil. Change the oil after every 50 hours of operation or at least once a year if the tractor is not used for 50 hours in one year. Check the crankcase oil level before starting the engine and after each eight (8) hours of operation. Tighten oil fill cap/dipstick securely each time you check the oil level.

TO CHANGE ENGINE OIL

Determine temperature range expected before oil change. All oil must meet API service classification SF-SJ.

- Be sure tractor is on level surface.
 - Oil will drain more freely when warm.
 - Catch oil in a suitable container.
1. Remove oil fill cap/dipstick. Be careful not to allow dirt to enter the engine when changing oil.
 2. Remove yellow cap from end of drain valve and install the drain tube onto the fitting.

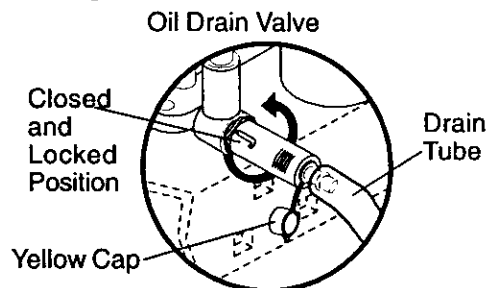

3. Unlock drain valve by pushing inward slightly and turning counterclockwise.
4. To open, pull out on the drain valve.
5. After oil has drained completely, close and lock the drain valve by pushing inward and turning clockwise until the pin is in the locked position as shown.
6. Remove the drain tube and replace the cap onto the end of the drain valve.

7. Refill engine with oil through oil fill dipstick tube. Pour slowly. Do not overfill. For approximate capacity see "PRODUCT SPECIFICATIONS" section of this manual.
8. Use gauge on oil fill cap/dipstick for checking level. For accurate reading, tighten dipstick cap securely onto the tube before removing dipstick. Keep oil at "FULL" line on dipstick. Tighten cap onto the tube securely when finished.

ENGINE OIL FILTER

Replace the engine oil filter every season or every other oil change if the tractor is used more than 100 hours in one year.

AIR FILTER

Your engine will not run properly using a dirty air filter. Clean the foam pre-cleaner after every 25 hours of operation or every season. Service paper cartridge every 100 hours of operation or every season, whichever occurs first.

Service air cleaner more often under dusty conditions.

1. Remove knobs and cover.

TO SERVICE PRE-CLEANER

2. Wash it in liquid detergent and water.
3. Squeeze it dry in a clean cloth.
4. Saturate it in engine oil. Wrap it in clean, absorbent cloth and squeeze to remove excess oil.

NOTE: If very dirty or damaged, replace pre-cleaner.

TO SERVICE CARTRIDGE

1. Clean cartridge by tapping gently on flat surface. If very dirty or damaged, replace cartridge.
2. Reinstall precleaner cartridge, cover and secure with knobs.

IMPORTANT: Petroleum solvents, such as kerosene, are not to be used to clean the cartridge. They may cause deterioration of the cartridge. Do not oil cartridge. Do not use pressurized air to clean or dry cartridge.

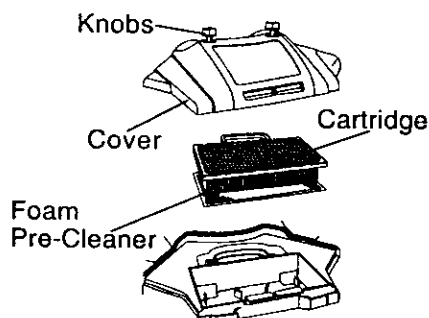

CLEAN AIR SCREEN

Air screen must be kept free of dirt and chaff to prevent engine damage from overheating. Clean with a wire brush or compressed air to remove dirt and stubborn dried gum fibers.

CLEAN AIR INTAKE/COOLING AREAS

To insure proper cooling, make sure the grass screen, cooling fins, and other external surfaces of the engine are kept clean at all times.

Every 100 hours of operation (more often under extremely dusty, dirty conditions), remove the blower housing and other cooling shrouds. Clean the cooling fins and external surfaces as necessary. Make sure the cooling shrouds are reinstalled.

NOTE: Operating the engine with a blocked grass screen, dirty or plugged cooling fins, and/or cooling shrouds removed will cause engine damage due to overheating.

MUFFLER

Inspect and replace corroded muffler and spark arrester (if equipped) as it could create a fire hazard and/or damage.

SPARK PLUG(S)

Replace spark plug(s) at the beginning of each mowing season or after every 100 hours of operation, whichever occurs first. Spark plug type and gap setting are shown in "PRODUCT SPECIFICATIONS" section of this manual.

IN-LINE FUEL FILTER

The fuel filter should be replaced once each season. If fuel filter becomes clogged, obstructing fuel flow to carburetor, replacement is required.

1. With engine cool, remove filter and plug fuel line sections.
2. Place new fuel filter in position in fuel line with arrow pointing towards carburetor.
3. Be sure there are no fuel line leaks and clamps are properly positioned.
4. Immediately wipe up any spilled gasoline.

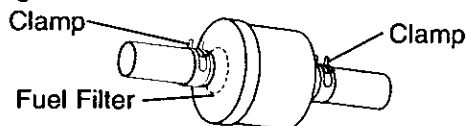

CLEANING

- Clean engine, battery, seat, finish, etc. of all foreign matter.
- Keep finished surfaces and wheels free of all gasoline, oil, etc.
- Protect painted surfaces with automotive type wax.

We do not recommend using a garden hose to clean your tractor unless the electrical system, muffler, air filter and carburetor are covered to keep water out. Water in engine can result in a shortened engine life.

SERVICE AND ADJUSTMENTS



WARNING: TO AVOID SERIOUS INJURY, BEFORE PERFORMING ANY SERVICE OR ADJUSTMENTS:

1. Depress brake pedal fully and set parking brake.
2. Place attachment clutch in "DISENGAGED" position.
3. Turn ignition key to "STOP" and remove key.
4. Make sure the blades and all moving parts have completely stopped.
5. Disconnect spark plug wire from spark plug and place wire where it cannot come in contact with plug.

TRACTOR

TO REMOVE MOWER

1. Place attachment clutch in "DISENGAGED" position.
2. If equipped, turn height adjustment knob to lowest setting.
3. Lower mower to its lowest position.
4. Remove retainer spring holding anti-sway bar to chassis bracket and disengage anti-sway bar from bracket.
5. Remove four retainer springs from front plate assembly and remove plate.
6. Remove retainer springs from suspension arms at deck and disengage arms from deck.
7. Raise attachment lift to its highest position.
8. Slide mower forward and remove belt from electric clutch pulley.
9. Slide mower out from under right side of tractor.

TO INSTALL MOWER

Be sure tractor is on level surface and mower suspension arms are raised with attachment lift control. Engage parking brake.

1. Swing anti-sway bar to left side of mower deck.
 2. Slide mower under tractor with deflector shield to right side of tractor.
- IMPORTANT:** Check belt for proper routing in all mower pulley grooves.
3. If equipped, turn height adjustment knob counterclockwise until it stops.
 4. Lower mower linkage with attachment lift control.
 5. Install belt into electric clutch pulley groove.
 6. Place the suspension arms on outward pointing deck pins. Retain with double loop retainer spring with loops up as shown.

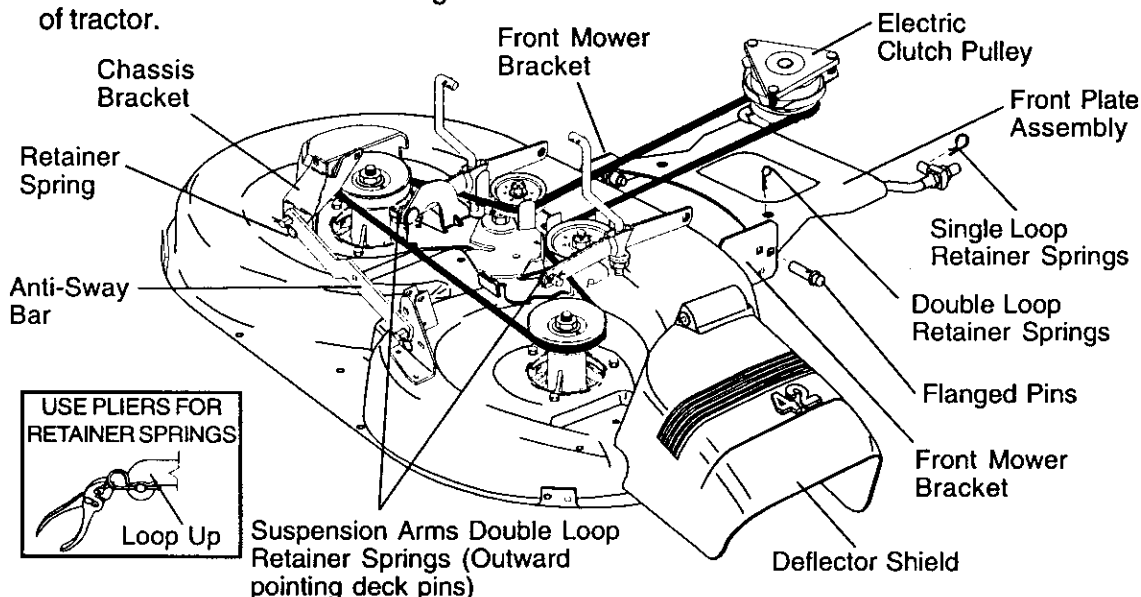

7. Install front plate assembly to tractor suspension brackets and retain with single loop retainer springs as shown.
 8. Position front plate assembly between front mower brackets. Raise deck and plate assembly to align holes and insert flanged pins. Secure pins with double loop retainer springs between the plate and mower brackets.
- NOTE:** To assist in locating hole in flanged pin, the hole in pin is inline with notch on head of pin. If necessary, move mower side-to-side to give space between plate and mower brackets.
- IMPORTANT:** Check belt for proper routing in all mower pulley grooves.
9. Connect anti-sway bar to chassis bracket under left footrest and retain with double loop retainer spring.
 10. If equipped, turn height adjustment knob clockwise to remove slack from mower suspension.
 11. Raise deck to highest position.

TO LEVEL MOWER HOUSING

Adjust the mower while tractor is parked on level ground or driveway. Make sure tires are properly inflated (See "PRODUCT SPECIFICATIONS" section of this manual). If tires are over or underinflated, you will not properly adjust your mower.

SIDE-TO-SIDE ADJUSTMENT WITH BUBBLE LEVEL

NOTE: If necessary, check side-to-side surface below tractor for levelness with a long board and the bubble level.

- Using the lift lever, place mower in position where no part of the mower, including gauge wheels, is touching the ground.
- From left side of tractor, find the level decal on top of mower and place bubble level on decal as indicated.
- Mower is level side-to-side when bubble is between the two lines in the bubble level.
- If adjustment is necessary, under left hand footrest, turn lift link adjustment nut (above yellow cap) in appropriate direction to bring bubble between the lines in the bubble level.
- Remove bubble level from mower and store in a safe place.

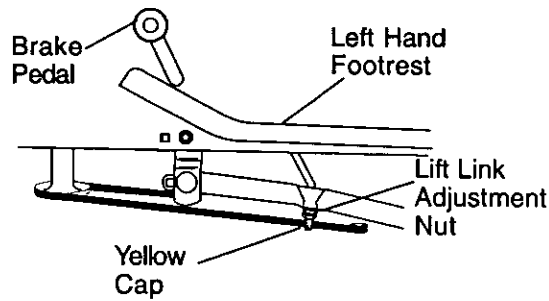
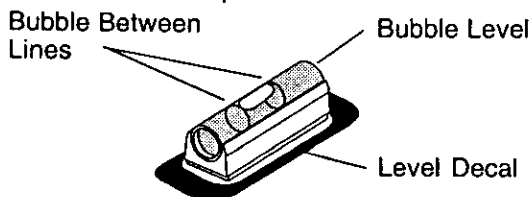

ALTERNATE SIDE-TO-SIDE ADJUSTMENT METHOD

- Raise mower to its highest position.
- At the midpoint of both sides of mower, measure height from bottom edge of mower to ground. Distance "A" on both sides of mower should be the same or within 1/4" of each other.
- If adjustment is necessary, make adjustment on one side of mower only.
- To raise one side of mower, tighten lift link adjustment nut on that side.
- To lower one side of mower, loosen lift link adjustment nut on that side.

NOTE: Each full turn of adjustment nut will change mower height about 1/8".

- Recheck measurements after adjusting.

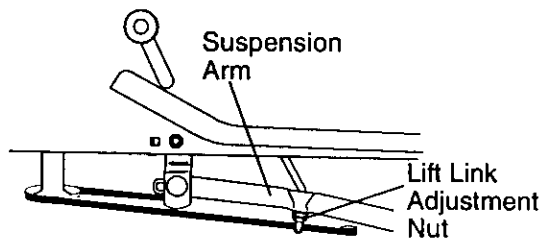
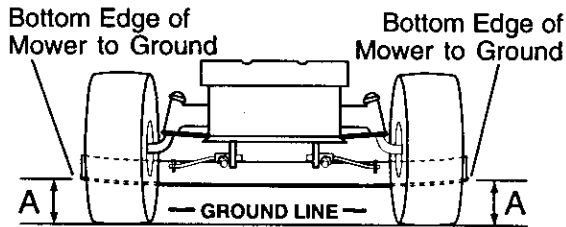

FRONT-TO-BACK ADJUSTMENT

IMPORTANT: Deck must be level side-to-side. If the following front-to-back adjustment is necessary, be sure to adjust both front links equally so mower will stay level side-to-side.

To obtain the best cutting results, the mower housing should be adjusted so that the front is approximately 1/8" to 1/2" lower than the rear when the mower is in its highest position.

Check adjustment on right side of tractor. Measure distance "D" directly in front of and behind the mandrel at bottom edge of mower housing as shown.

- Before making any necessary adjustments, check that both front plate links are equal in length.
- If links are not equal in length, adjust one link to same length as other link.
- To lower front of mower loosen nut "E" on both front links an equal number of turns.
- When distance "D" is 1/8" to 1/2" lower at front than rear, tighten nuts "F" against trunnion on both front links.
- To raise front of mower, loosen nut "F" from trunnion on both front links. Tighten nut "E" on both front links an equal number of turns. The two front links must remain equal in length.
- When distance "D" is 1/8" to 1/2" lower at front than rear, tighten nut "F" against trunnion on both front links.
- Recheck side-to-side adjustment. Measure distance "D" directly in front of and behind the mandrel at bottom edge of mower housing as shown.
- Before making any necessary adjustments, check that both front links are equal in length.
- If links are not equal in length, adjust one link to same length as other link.
- To lower front of mower loosen nut "E" on both front links an equal number of turns.
- When distance "D" is 1/8" to 1/2" lower at front than rear, tighten nuts "F" against trunnion on both front links.
- To raise front of mower, loosen nut "F" from trunnion on both front links. Tighten nut "E" on both front links an equal number of turns. The two front links must remain equal in length.
- When distance "D" is 1/8" to 1/2" lower at front than rear, tighten nut "F" against trunnion on both front links.
- Recheck side-to-side adjustment.

BOTH FRONT PLATE LINKS MUST BE EQUAL IN LENGTH

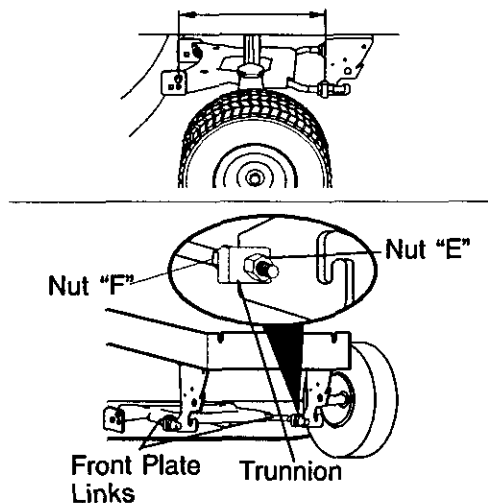

TO REPLACE MOWER BLADE DRIVE BELT

The mower blade drive belt may be replaced without tools. Park the tractor on level surface. Engage parking brake.

BELT REMOVAL -

1. Remove mower from tractor (See "TO REMOVE MOWER" in this section of manual).
2. Work belt off both mandrel pulleys and idler pulleys.
3. Pull belt away from mower.

BELT INSTALLATION -

1. Work belt around both mandrel pulleys and idler pulleys
2. Make sure belt is in all pulley grooves and inside all belt guides.
3. Install mower (See "To Install Mower" in this section of this manual).

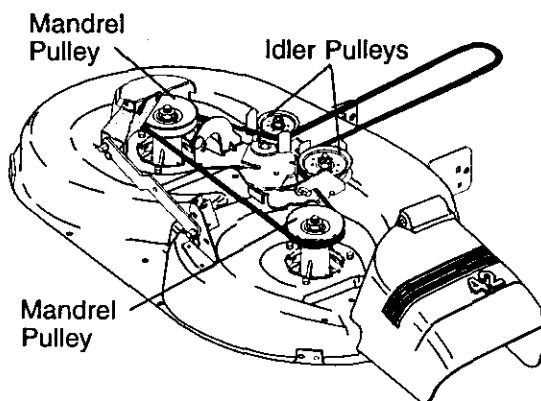
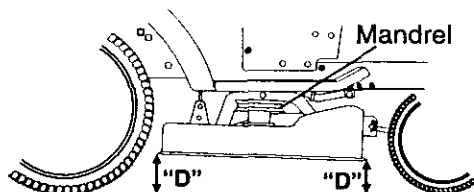

TO CHECK AND ADJUST BRAKE

Your tractor is equipped with an adjustable brake system which is mounted on the right side of the transaxle.

If tractor requires more than five (5) feet to stop at highest speed in highest gear on a level, dry concrete or paved surface, then brake must be checked and adjusted.

TO CHECK BRAKE

1. Park tractor on a level, dry concrete or paved surface, depress clutch/brake pedal all the way down and engage parking brake.
2. Disengage transmission by placing freewheel control in "transmission disengaged" position. Pull freewheel control out and into the slot and release so it is held in the disengaged position.

The rear wheels must lock and skid when you try to manually push the tractor forward. If the rear wheels rotate, the brake needs to be adjusted or the pads need to be replaced.

TO ADJUST BRAKE

1. Depress clutch/brake pedal all the way down and engage parking brake.
2. Measure distance between brake operating arm and nut "A" on brake rod.
3. If distance is other than 1-3/4", loosen jam nut and turn nut "A" until distance becomes 1-3/4". Retighten jam nut against nut "A".
4. Engage transmission by placing freewheel control in "transmission engaged" position.
5. Road test tractor for proper stopping distance as stated above. Readjust if necessary. If stopping distance is still greater than five (5) feet in highest gear, further maintenance is necessary. Replace brake pads or contact a Sears or other qualified service center.

With parking brake "Engaged"

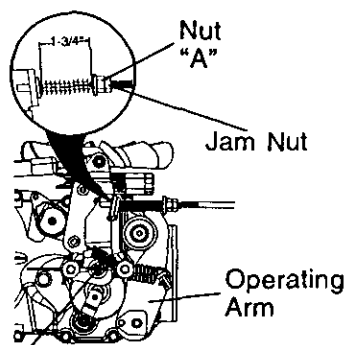

Do not touch this nut. If further brake adjustment is necessary contact a Sears or other qualified service center.

TO REPLACE MOTION DRIVE BELT

Park the tractor on level surface. Engage parking brake. For assistance, there is a belt installation guide decal on bottom side of left footrest.

BELT REMOVAL -

1. Remove mower (See "TO REMOVE MOWER" in this section of manual).
- NOTE:** Observe entire motion drive belt and position of all belt guides and keepers.
2. Disconnect clutch wire harness.
 3. Remove clutch locator.
 4. Remove belt from stationary idler and clutching idler.
 5. Remove belt downward from engine pulley and around electric clutch.
 6. Pull belt slack toward rear of tractor. Carefully remove belt upwards from transmission input pulley and over cooling fan blades.
 7. Remove belt from center span keeper and pull belt away from tractor.

BELT INSTALLATION -

1. Carefully work new belt down around transmission cooling fan and onto the input pulley.
2. Slide belt into the center span keeper.
3. Pull belt toward front of tractor and roll belt around electric clutch and onto engine pulley.
4. Install belt through stationary idler and clutching idler.
5. Reinstall clutch locator and tighten nut securely.
6. Reconnect clutch harness.
7. Make sure belt is in all pulley grooves and inside all belt guides and keepers.
8. Install mower (See "TO INSTALL MOWER" in this section of manual).

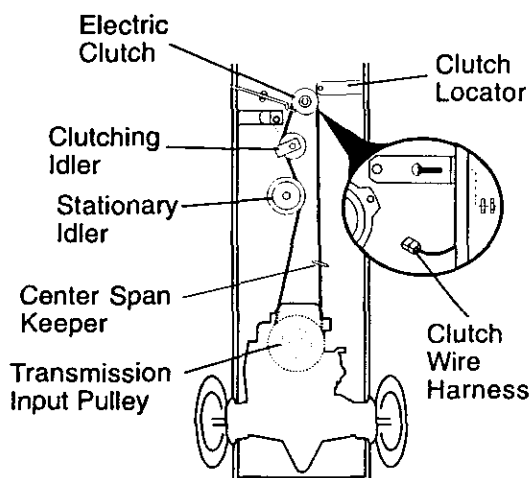

TRANSMISSION REMOVAL/REPLACEMENT

Should your transmission require removal for service or replacement, it should be purged after reinstallation and before operating the tractor. See "PURGE TRANSMISSION" in the Operation section of this manual.

TO ADJUST STEERING WHEEL ALIGNMENT

If steering wheel crossbars are not horizontal (left to right) when wheels are positioned straight forward, remove steering wheel and reassemble with crossbars horizontal. Tighten securely.

FRONT WHEEL TOE-IN/CAMBER

The front wheel toe-in and camber are not adjustable on your tractor. If damage has occurred to affect the front wheel toe-in or camber, contact a Sears or other qualified service center.

TO REMOVE WHEEL FOR REPAIRS

1. Block up axle securely.
2. Remove axle cover, retaining ring and washers to allow wheel removal (rear wheels have a square key - Do not lose).
3. Repair tire and reassemble.

NOTE: On rear wheels only: align grooves in rear wheel hub and axle. Insert square key.

4. Replace washers and snap retaining ring securely in axle groove.
5. Replace axle cover.

NOTE: To seal tire punctures and prevent flat tires due to slow leaks, purchase and use tire sealant from Sears. Tire sealant also prevents tire dry rot and corrosion.

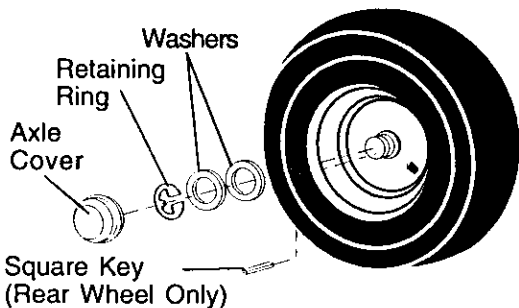

TO START ENGINE WITH A WEAK BATTERY

WARNING: Lead-acid batteries generate explosive gases. Keep sparks, flame and smoking materials away from batteries. Always wear eye protection when around batteries.

If your battery is too weak to start the engine, it should be recharged. (See "BATTERY" in the MAINTENANCE section of this manual).

If "jumper cables" are used for emergency starting, follow this procedure:

IMPORTANT: Your tractor is equipped with a 12 volt system. The other vehicle must also be a 12 volt system. Do not use your tractor battery to start other vehicles.

TO ATTACH JUMPER CABLES -

1. Connect one end of the RED cable to the POSITIVE (+) terminal of each battery(A-B), taking care not to short against tractor chassis.
2. Connect one end of the BLACK cable to the NEGATIVE (-) terminal (C) of fully charged battery.
3. Connect the other end of the BLACK cable (D) to good chassis ground, away from fuel tank and battery.

TO REMOVE CABLES, REVERSE ORDER -

1. BLACK cable first from chassis and then from the fully charged battery.
2. RED cable last from both batteries.

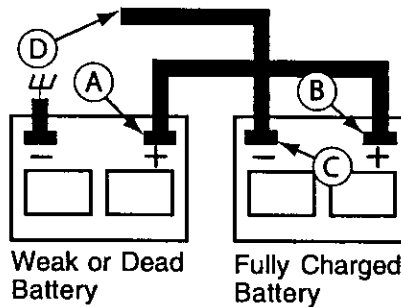

REPLACING BATTERY

WARNING: Do not short battery terminals by allowing a wrench or any other object to contact both terminals at the same time. Before connecting battery, remove metal bracelets, wristwatch bands, rings, etc.

Positive terminal must be connected first to prevent sparking from accidental grounding.

1. Lift hood to raised position.
2. Remove terminal guard.
3. Disconnect BLACK battery cable then RED battery cable and carefully remove battery from tractor.
4. Install new battery with terminals in same position as old battery.
5. Reinstall terminal guard.
6. First connect RED battery cable to positive (+) battery terminal with hex bolt and keps nut as shown. Tighten securely.

7. Connect BLACK grounding cable to negative (-) battery terminal with remaining hex bolt and keps nut. Tighten securely
8. Close terminal access doors.
9. Close hood.

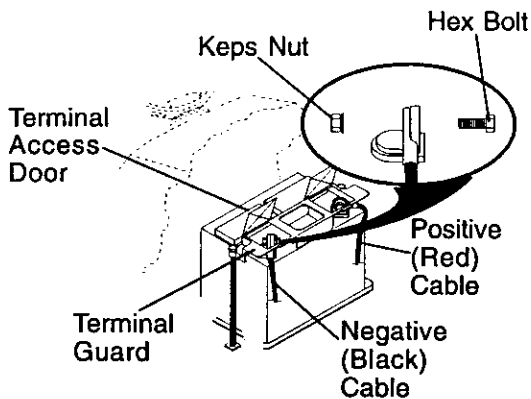

TO REMOVE HOOD AND GRILL ASSEMBLY

1. Raise hood.
2. Unsnap headlight wire connector.
3. Stand in front of tractor. Grasp hood at sides, tilt toward engine and lift off of tractor.
4. When replacing hood, be sure to reconnect the headlight wire connector.

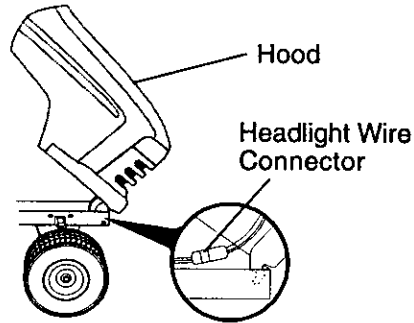

TO REPLACE HEADLIGHT LAMP

CAUTION: When lit, the halogen lamps get extremely hot. Hold lamp assembly by the holder and do not touch the bulb.

1. Raise hood.
2. Disconnect harness from lamp assembly.
3. Rotate counterclockwise and pull lamp assembly out of the hole in the backside of the grill.
4. Insert new lamp assembly and rotate clockwise to lock.
5. Reconnect harness to lamp assembly.
6. Close hood.

INTERLOCKS AND RELAYS

Loose or damaged wiring may cause your tractor to run poorly, stop running, or prevent it from starting.

- Check wiring. See electrical wiring diagram in the Repair Parts section.

TO REPLACE FUSE

Replace with 20 amp automotive-type plug-in fuse. The fuse holder is located behind the dash.

ENGINE

Maintenance, repair, or replacement of the emission control devices and systems, which are being done at the customer's expense, may be performed by any non-road engine repair establishment or individual. Warranty repairs must be performed by an authorized engine manufacturer's service outlet.

TO ADJUST THROTTLE CONTROL CABLE

The throttle control has been preset at the factory and adjustment should not be necessary. Check adjustment as described below before loosening cable. If adjustment is necessary, proceed as follows:

1. With engine not running, move throttle control lever to fast position.
2. Check that swivel is against stop. If it is not, loosen cable clamp screw and pull cable back until swivel is against stop. Tighten cable clamp screw securely.

TO ADJUST CHOKE CONTROL

The choke control has been preset at the factory and adjustment should not be necessary. Check adjustment as described below before loosening cable. If adjustment is necessary, proceed as follows:

1. With engine not running, move choke control (located on dash panel) to full choke position.
2. Loosen knob and remove cover assembly from air cleaner.
3. Choke should be closed. If it is not, loosen casing clamp screw and move choke cable until choke is completely closed. Tighten casing clamp screw securely.
4. Replace air cleaner cover assembly and tighten knob.

TO ADJUST CARBURETOR

Your carburetor is not adjustable. If your engine does not operate properly due to suspected carburetor problems, take your tractor to an authorized service center for repair and/or adjustment.

High speed stop is factory adjusted. Do not adjust - damage may result.

IMPORTANT: Never tamper with the engine governor, which is factory set for proper engine speed. Overspeeding the engine above the factory high speed setting can be dangerous. If you think the engine-governed high speed needs adjusting, contact a Sears or other qualified service center, which has proper equipment and experience to make any necessary adjustments.

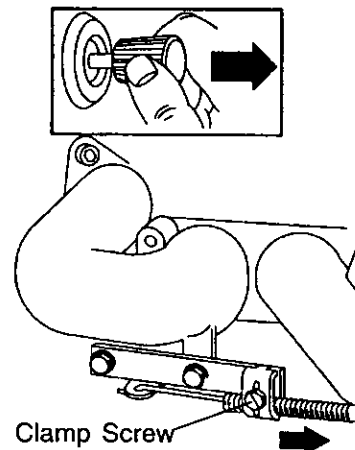
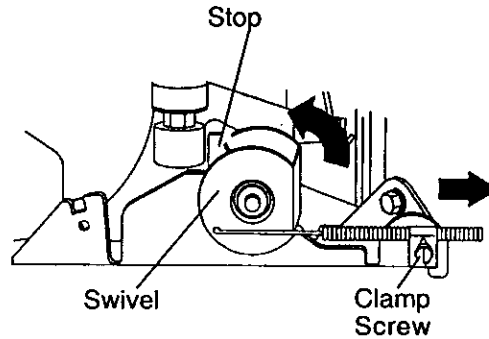

STORAGE

Immediately prepare your tractor for storage at the end of the season or if the tractor will not be used for 30 days or more.

⚠ WARNING: Never store the tractor with gasoline in the tank inside a building where fumes may reach an open flame or spark. Allow the engine to cool before storing in any enclosure.

TRACTOR

Remove mower from tractor for winter storage. When mower is to be stored for a period of time, clean it thoroughly, remove all dirt, grease, leaves, etc. Store in a clean, dry area.

1. Clean entire tractor (See "CLEANING" in the Maintenance section of this manual).
2. Inspect and replace belts, if necessary (See belt replacement instructions in the Service and Adjustments section of this manual).
3. Lubricate as shown in the Maintenance section of this manual.
4. Be sure that all nuts, bolts and screws are securely fastened. Inspect moving parts for damage, breakage and wear. Replace if necessary.
5. Touch up all rusted or chipped paint surfaces; sand lightly before painting.

BATTERY

- Fully charge the battery for storage.
- After a period of time in storage, battery may require recharging.
- To help prevent corrosion and power leakage during long periods of storage, battery cables should be disconnected and battery cleaned thoroughly (see "TO CLEAN BATTERY AND TERMINALS" in the Maintenance section of this manual).
- After cleaning, leave cables disconnected and place cables where they cannot come in contact with battery terminals.
- If battery is removed from tractor for storage, do not store battery directly on concrete or damp surfaces.

ENGINE

FUEL SYSTEM

IMPORTANT: It is important to prevent gum deposits from forming in essential fuel system parts such as carburetor, fuel hose, or tank during storage.

Also, alcohol blended fuels (called gasohol or using ethanol or methanol) can attract moisture which leads to separation and formation of acids during storage. Acidic gas can damage the fuel system of an engine while in storage.

1. Drain the fuel tank.
 2. Start the engine and let it run until the fuel lines and carburetor are empty.
- Never use engine or carburetor cleaner products in the fuel tank or permanent damage may occur.
 - Use fresh fuel next season.

NOTE: Fuel stabilizer is an acceptable alternative in minimizing the formation of fuel gum deposits during storage. Add stabilizer to gasoline in fuel tank or storage container. Always follow the mix ratio found on stabilizer container. Run engine at least 10 minutes after adding stabilizer to allow the stabilizer to reach the carburetor. Do not drain the gas tank and carburetor if using fuel stabilizer.

ENGINE OIL

Drain oil (with engine warm) and replace with clean engine oil. (See "ENGINE" in the Maintenance section of this manual).

CYLINDER(S)

1. Remove spark plug(s).
2. Pour one ounce of oil through spark plug hole(s) into cylinder(s).
3. Turn ignition key to start position for a few seconds to distribute oil.
4. Replace with new spark plug(s).

OTHER

- Do not store gasoline from one season to another.
- Replace your gasoline can if your can starts to rust. Rust and/or dirt in your gasoline will cause problems.
- If possible, store your tractor indoors and cover it to give protection from dust and dirt.
- Cover your tractor with a suitable protective cover that does not retain moisture. Do not use plastic. Plastic cannot breathe which allows condensation to form and will cause your tractor to rust.

IMPORTANT: Never cover tractor while engine and exhaust areas are still warm.

TROUBLESHOOTING CHART:

See appropriate section in manual unless directed to Sears service center

PROBLEM	CAUSE	CORRECTION
Will not start	<ol style="list-style-type: none"> 1. Out of fuel. 2. Engine not "CHOKED" properly. 3. Engine flooded. 4. Bad spark plug. 5. Dirty air filter. 6. Dirty fuel filter. 7. Water in fuel. 8. Loose or damaged wiring. 9. Carburetor out of adjustment. 10. Engine valves out of adjustment. 	<ol style="list-style-type: none"> 1. Fill fuel tank. 2. See "TO START ENGINE" in Operation section. 3. Wait several minutes before attempting to start. 4. Replace spark plug. 5. Clean/replace air filter. 6. Replace fuel filter. 7. Drain fuel tank and carburetor, refill tank with fresh gasoline and replace fuel filter. 8. Check all wiring. 9. See "To Adjust Carburetor" in Service and Adjustments section. 10. Contact a Sears or other qualified service center.
Hard to start	<ol style="list-style-type: none"> 1. Dirty air filter. 2. Bad spark plug. 3. Weak or dead battery. 4. Dirty fuel filter. 5. Stale or dirty fuel. 6. Loose or damaged wiring. 7. Carburetor out of adjustment. 8. Engine valves out of adjustment. 	<ol style="list-style-type: none"> 1. Clean/replace air filter. 2. Replace spark plug. 3. Recharge or replace battery. 4. Replace fuel filter. 5. Drain fuel tank and refill with fresh gasoline. 6. Check all wiring. 7. See "To Adjust Carburetor" in Service and Adjustments section. 8. Contact a Sears or other qualified service center.
Engine will not turn over	<ol style="list-style-type: none"> 1. Brake pedal not depressed 2. Attachment clutch is engaged. 3. Weak or dead battery. 4. Blown fuse. 5. Corroded battery terminals. 6. Loose or damaged wiring. 7. Faulty ignition switch. 8. Faulty solenoid or starter. 9. Faulty operator presence switch(es). 	<ol style="list-style-type: none"> 1. Depress brake pedal. 2. Disengage attachment clutch. 3. Recharge or replace battery. 4. Replace fuse. 5. Clean battery terminals. 6. Check all wiring. 7. Check/replace ignition switch. 8. Check/replace solenoid or starter. 9. Contact a Sears or other qualified service center.
Engine clicks but will not start	<ol style="list-style-type: none"> 1. Weak or dead battery. 2. Corroded battery terminals. 3. Loose or damaged wiring. 4. Faulty solenoid or starter. 	<ol style="list-style-type: none"> 1. Recharge or replace battery. 2. Clean battery terminals. 3. Check all wiring. 4. Check/replace solenoid or starter.
Loss of power	<ol style="list-style-type: none"> 1. Cutting too much grass/too fast. 2. Throttle in "CHOKE" position. 	<ol style="list-style-type: none"> 1. Set in "Higher Cut" position/ reduce speed. 2. Adjust throttle control.

TROUBLESHOOTING CHART:

See appropriate section in manual unless directed to Sears service center

PROBLEM	CAUSE	CORRECTION
Loss of power (continued)	3. Build-up of grass, leaves and trash under mower. 4. Dirty air filter. 5. Low oil level/dirty oil. 6. Faulty spark plug. 7. Dirty fuel filter. 8. Stale or dirty fuel. 9. Water in fuel. 10. Spark plug wire loose. 11. Dirty engine air screen/fins. 12. Dirty/clogged muffler. 13. Loose or damaged wiring. 14. Carburetor out of adjustment. 15. Engine valves out of adjustment.	3. Clean underside of mower housing. 4. Clean/replace air filter. 5. Check oil level/change oil. 6. Clean and regap or change spark plug. 7. Replace fuel filter. 8. Drain fuel tank and refill with fresh gasoline. 9. Drain fuel tank and carburetor, refill tank with fresh gasoline and replace fuel filter. 10. Connect and tighten spark plug wire. 11. Clean engine air screen/fins. 12. Clean/replace muffler. 13. Check all wiring. 14. See "To Adjust Carburetor" in Service and Adjustments section. 15. Contact a Sears or other qualified service center.
Excessive vibration	1. Worn, bent or loose blade. 2. Bent blade mandrel. 3. Loose/damaged part(s).	1. Replace blade. Tighten blade bolt. 2. Contact a Sears or other qualified service center. 3. Tighten loose part(s). Replace damaged parts.
Engine continues to run when operator leaves seat with attachment clutch engaged	1. Faulty operator-safety presence control system.	1. Check wiring, switches and connections. If not corrected, contact a Sears or other qualified service center.
Poor cut - uneven	1. Worn, bent or loose blade. 2. Mower deck not level. 3. Buildup of grass, leaves, and trash under mower. 4. Bent blade mandrel. 5. Clogged mower deck vent from build-up of grass, leaves, and trash around mandrels.	1. Replace blade. Tighten blade bolt. 2. Level mower deck. 3. Clean underside of mower housing. 4. Contact a Sears or other qualified service center. 5. Clean around mandrels to open vent holes.
Mower blades will not rotate	1. Obstruction in clutch mechanism.	1. Remove obstruction.

TROUBLESHOOTING CHART:

See appropriate section in manual unless directed to Sears service center

PROBLEM	CAUSE	CORRECTION
Mower blades will not rotate (con't)	<ol style="list-style-type: none">2. Worn/damaged mower drive belt.3. Frozen idler pulley.4. Frozen blade mandrel.	<ol style="list-style-type: none">2. Replace mower drive belt.3. Replace idler pulley.4. Contact a Sears or other qualified service center.
Poor grass discharge	<ol style="list-style-type: none">1. Engine speed too slow.2. Travel speed too fast.3. Wet grass.4. Mower deck not level.5. Low/uneven tire air pressure.6. Worn, bent or loose blade.7. Buildup of grass, leaves and trash under mower.8. Mower drive belt worn.9. Blades improperly installed.10. Improper blades used.11. Clogged mower deck vent holes from buildup of grass, leaves, and trash around mandrels.	<ol style="list-style-type: none">1. Place throttle control in "FAST" position.2. Shift to slower speed.3. Allow grass to dry before mowing.4. Level mower deck.5. Check tires for proper air pressure.6. Replace/sharpen blade. Tighten blade bolt.7. Clean underside of mower housing.8. Replace mower drive belt.9. Reinstall blades sharp edge down.10. Replace with blades listed in this manual.11. Clean around mandrels to open vent holes.
Headlight(s) not working (if so equipped)	<ol style="list-style-type: none">1. Switch is "OFF".2. Bulb(s) or lamp(s) burned out.3. Faulty light switch.4. Loose or damaged wiring.5. Blown fuse.	<ol style="list-style-type: none">1. Turn switch "ON".2. Replace bulb(s) or lamp(s).3. Check/replace light switch.4. Check wiring and connections.5. Replace fuse.
Battery will not charge	<ol style="list-style-type: none">1. Bad battery cell(s).2. Poor cable connections.3. Faulty regulator (if so equipped).4. Faulty alternator.	<ol style="list-style-type: none">1. Replace battery.2. Check/clean all connections.3. Replace regulator.4. Replace alternator.
Loss of drive	<ol style="list-style-type: none">1. Freewheel control in "disengaged" position.2. Motion drive belt worn, damaged, or broken.3. Air trapped in transmission during shipment or servicing.	<ol style="list-style-type: none">1. Place freewheel control in "engaged" position.2. Replace motion drive belt.3. Purge transmission.
Engine "backfires" when turning engine "OFF"	<ol style="list-style-type: none">1. Engine throttle control not set at "SLOW" position for 30 seconds before stopping engine.	<ol style="list-style-type: none">1. Move throttle control to "SLOW" position and allow to idle for 30 seconds before stopping engine.

SERVICE NOTES

TRACTOR -- MODEL NUMBER 917.272282

SCHEMATIC

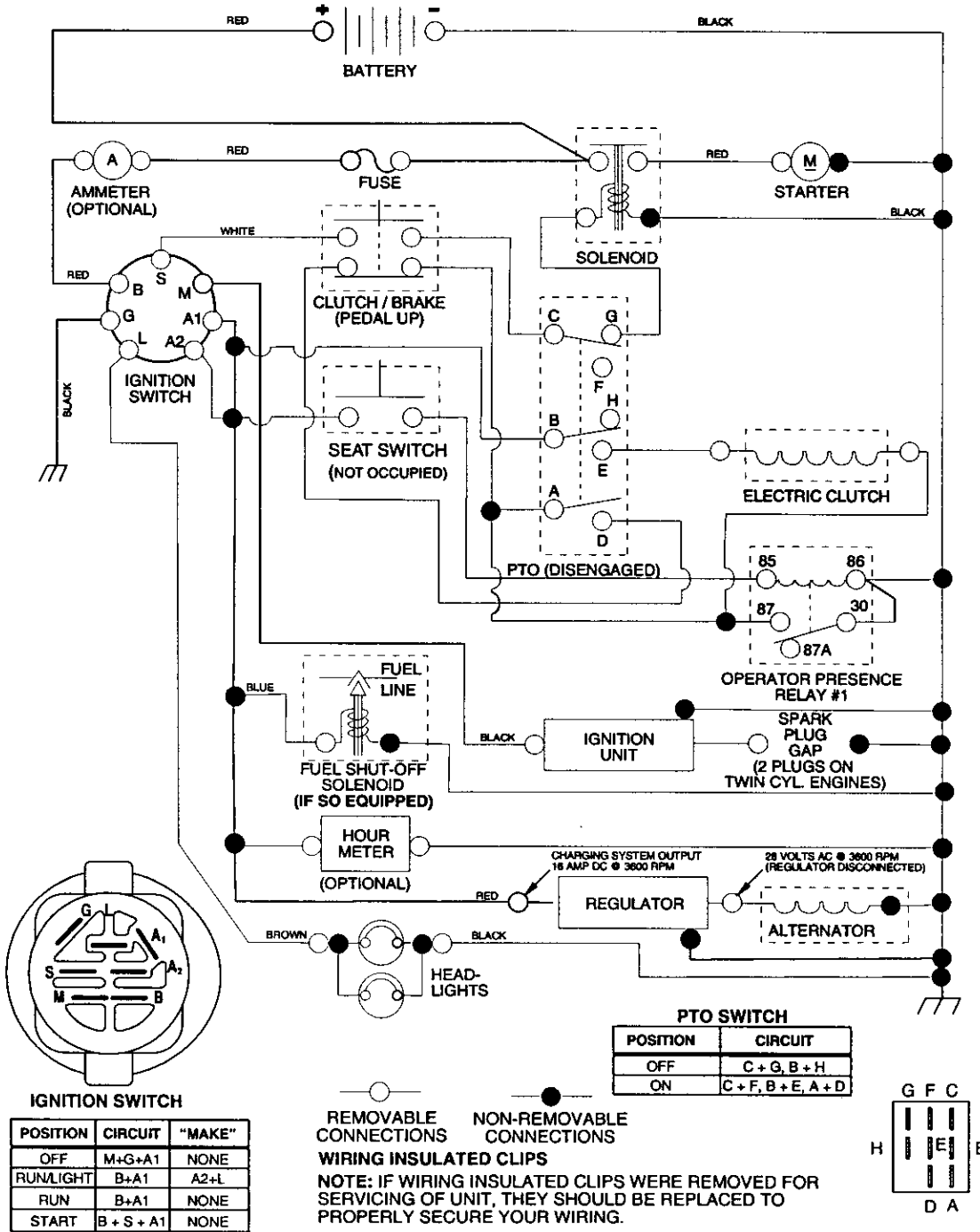

REPAIR PARTS

TRACTOR -- MODEL NUMBER 917.272282

ELECTRICAL

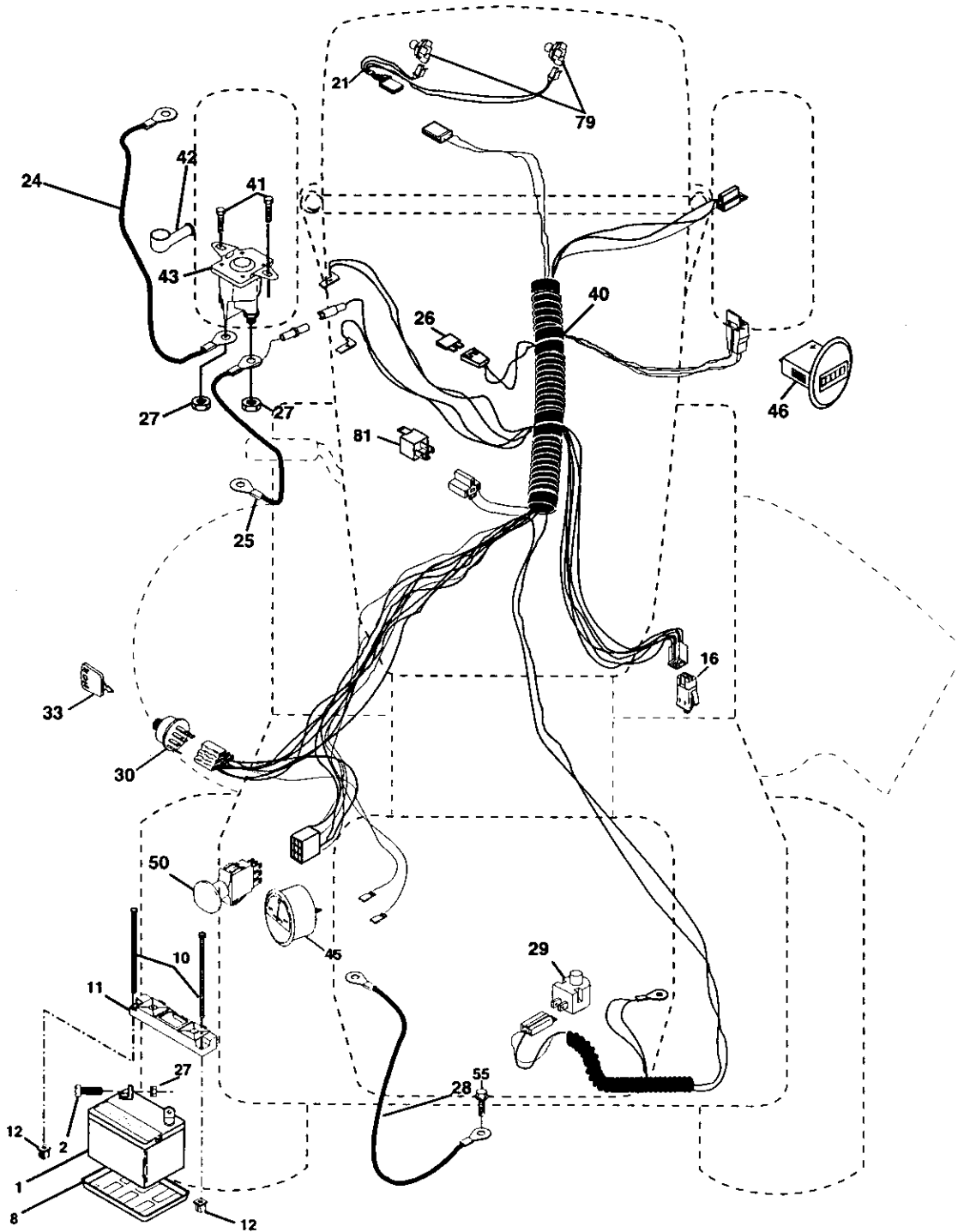

ELECTRICAL**TRACTOR -- MODEL NUMBER 917.272282**

KEY PART NO.	PART NO.	DESCRIPTION
1	163465	Battery
2	74760412	Bolt, Hex 1/4-20 x 3/4
8	7603J	Tray, Battery
10	145211	Bolt, Btr Front 1/4-20 x 7-1/2
11	150109	Holddown Battery Front Mount
12	145769	Nut, Push Nylon Battery Front 1/4
16	176138	Switch Interlock
21	175449	Harness, Light
24	4799J	Cable, Battery
25	146148	Cable, Battery
26	175158	Fuse
27	73510400	Nut Keps Hex 1/4-20 UNC
28	145491	Cable, Ground
29	160784	Switch, Seat
30	175442	Switch, Ignition
33	175447	Key
40	179737	Harness, Ignition
41	71110408	Bolt Fin Hex 1/4-20 Unc x 1/2
42	131563	Cover, Terminal
43	178861	Solenoid
45	175500	Ammeter
46	177501	Hourmeter
50	178461	Switch Pto
55	17490508	Screw Thdrol 5/16-18 x 1/2
79	175448	Lamp and Holder Asm
81	109748X	Relay Asm

NOTE: All component dimensions given in U.S. inches
1 inch = 25.4 mm

TRACTOR -- MODEL NUMBER 917.272282

CHASSIS AND ENCLOSURES

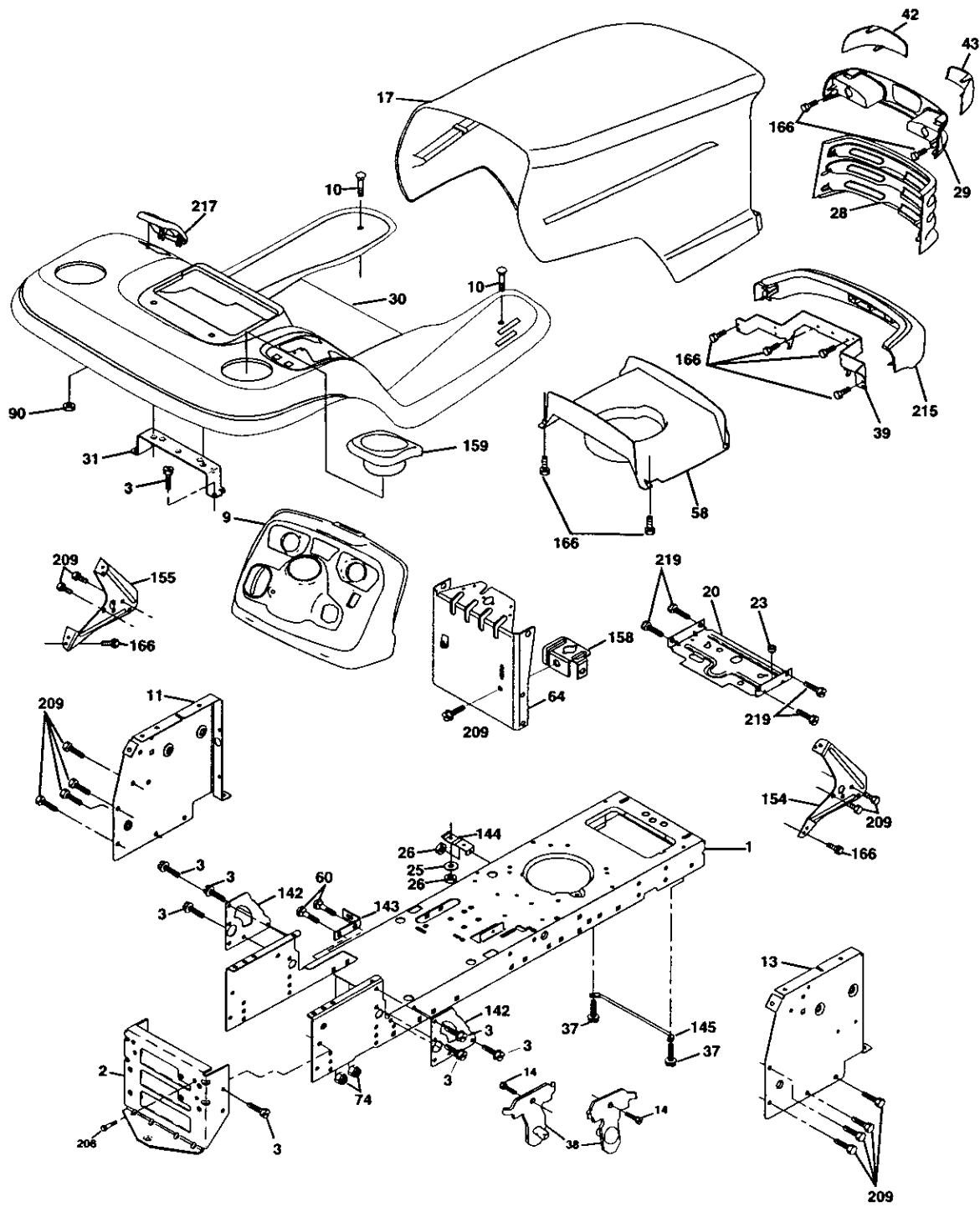

TRACTOR -- MODEL NUMBER 917.272282
CHASSIS AND ENCLOSURES

KEY	PART	
NO.	NO.	DESCRIPTION
1	174619	Chassis
2	176554	Drawbar
3	17060612	Screw, 3/8-16 x 3/4
9	172542X418	Dash
11	174996	Panel, Dash, LH
10	72140608	Bolt 3/8-16 x 1
13	179174X010	Panel, Dash, RH
14	17490608	Screw Thdrol 3/8-16 x 1/2
17	172540X615	Hood Assembly
20	180679	Plate Battery
23	124028X	Bushing Snap
25	19131312	Washer 13/32 x 13/16 x 12 Gauge
26	STD541437	Locknut, Hex, with Insert 3/8-16 UNC
28	174945X418	Grille
29	174944X418	Lightbox Dual
30	179131X615	Fender/Footrest
31	139976	Bracket, Fender/Support
37	17490508	Screw, Thdrol. 5/16-18 x 1/2 TYT
38	175710	Bracket Asm Pivot Mower Rear
39	174988	Bracket Pivot Hood
42	172545X599	Lens Lh
43	172544X599	Lens Rh
58	174993	Duct Hood
60	STD533707	Bolt Rdhd Sqnk 3/8-16 UNC x 3/4
64	174997	Dash Lower
74	STD541437	Nut Crownlock 3/8-16 UNC
90	124346X	Nut Self Thd Wsh Hd 1/4
142	175702	Plate Reinforcement
143	154966	Bracket Swaybar Chassis
144	175582	Bracket Footrest
145	156524	Rod Pivot Chassis/Hood
154	174679	Bracket Dash Rh
155	174680	Bracket Dash Lh
158	162037	Parking Brake Bkrt
159	179950X418	Cupholder Stil Blk
166	164863	HWHDH:-Lo. #13-16 x 3/4
206	170165	Bolt Shoulder 5/16-18
209	17000612	Screw Hexwsh Thdr 3/8-16 x 3/4
215	172543X615	Bumper
217	179132X418	Console Fuel Window Stil
219	17000512	Screw 5/16-18 x 3/4

NOTE: All component dimensions given in U.S. inches
 1 inch = 25.4 mm

TRACTOR -- MODEL NUMBER 917.272282

GROUND DRIVE

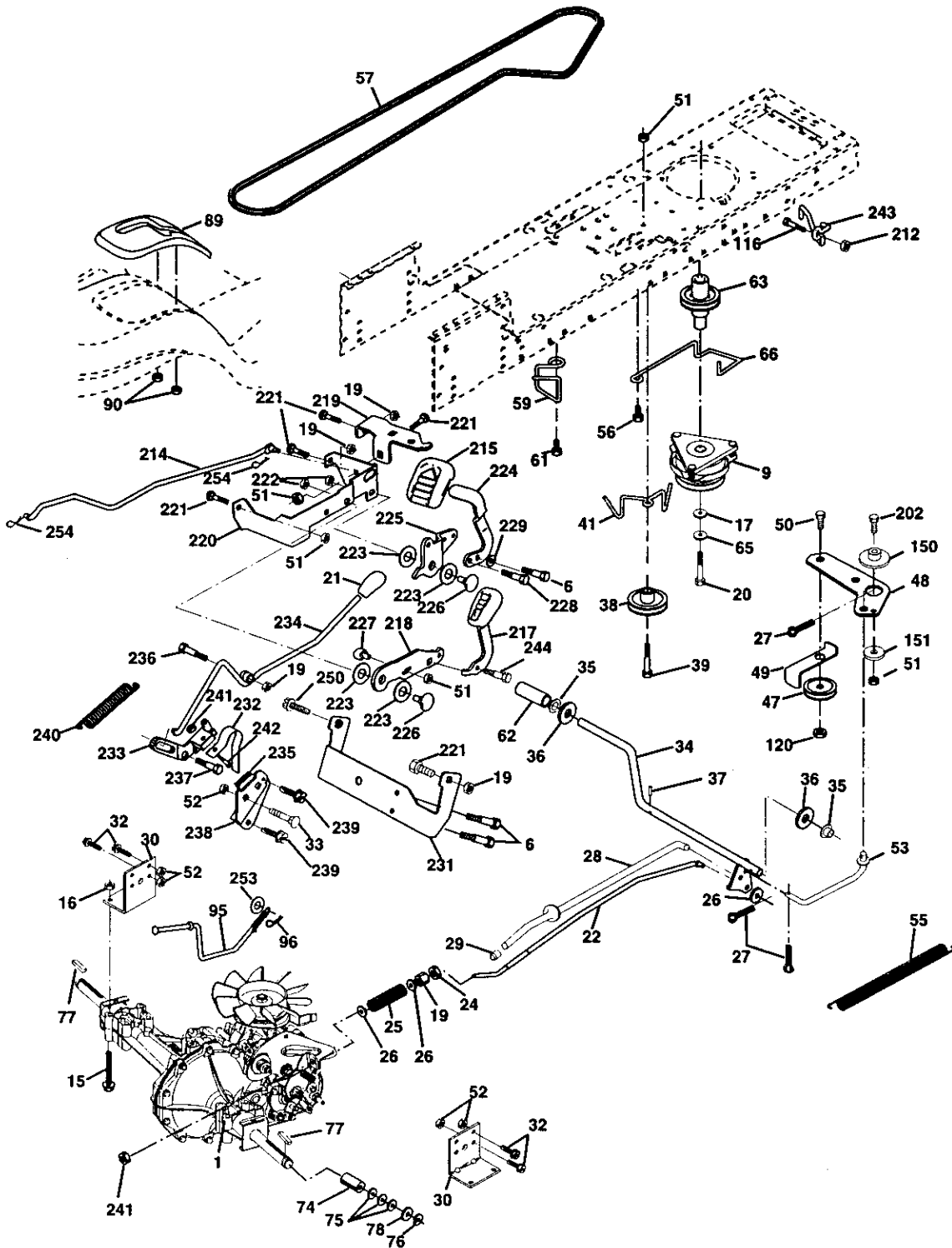

TRACTOR -- MODEL NUMBER 917.272282

GROUND DRIVE

KEY PART NO.	PART NO.	DESCRIPTION	KEY PART NO.	PART NO.	DESCRIPTION
1	-----	Transaxle (See Breakdown)	77	123583X	Key, Square
		Hydro gear Model 336-0510	78	121748X	Washer 25/32 x 1-5/8 x 16 Ga.
6	17060512	Screw 5/16-18 x 3/4	89	174901X418	Console, Shift
9	137140	Clutch Elec	90	124346X	Nut Self-Thd Wsh-hd 1/4 Zinc
15	74490544	Bolt Hex Flghd 5/16-18 Gr. 5	95	180825	Rod Bypass
16	73800500	Nut Lock Hex W/Ins. 5/16-18 Unc	96	4497H	Retainer Spring 1" Zinc/Cad
17	126197X	Washer 1-1/2 OD x 15/32 ID x .250	116	72140608	Bolt RDHD SQNK 3/8-16 Unc x 1
			120	73900600	Nut Lock Flg 3/8-16 Unc
19	73800600	Nut Lock Hex W/Wsh 3/8-16 Unc	150	175456	Spacer Retainer
20	150280	Bolt Hex 7/16-20 x 4 x 1/4	151	19133210	Washer 13/32 x 2 x 10 Ga.
21	175036X505	Knob Custom Control Cruise	202	72110612	Bolt Carr Sh 3/8-16 x 1-1/2 Gr. 5
22	175896	Rod, Brake	212	145212	Nut Hex Flange Lock
24	73350600	Nut, Hex Jam 3/8-16 Unc	214	174735	Link Transaxle
25	106888X	Spring, Brake Rod	215	175646	Cover Pedal Forward
26	19131316	Washer	217	179433	Pedal Reverse Asm. w/Pad
27	76020412	Pin Cotter 1/8 x 3/4 CAD.	218	174713	Arm Control Pedal Reverse
28	179607	Rod, Parking Brake	219	174839	Bracket Frest Pdl Ctr. Hyd
29	179608X505	Knob Brake Parking	220	174711	Bracket Mtg. Pedal Control
30	169592	Bracket, Transaxle	221	72140606	Bolt Rdhd Sqnk 3/8-16 Unc x 3/4
32	74760512	Bolt Hex Hd 5/16-18 Unc x 3/4	222	73680700	Nut Crownlock 7/16-14 Unc
33	72140506	Bolt Rdhd Sqnk 5/16-18 Unc x 3/4	223	174840	Washer Nylon 11/16 ID x .060
34	175578	Shaft, Foot Pedal	224	174736	Pedal Forward
35	120183X	Bearing, Nylon	225	174712	Arm Control Pedal Forward
36	19211616	Washer	226	174902	Bolt Pivot Spacer
37	1572H	Pin, Roll	227	174710	Cam Reverse Pedal LT
38	179114	Pulley, Composite	228	179032	Bolt Shoulder 5/16-18
39	74760648	Bolt Fin Hex 3/8-16 Unc x 3	229	176451	Washer Serrated 5/16 x .75
41	175556	Keeper, Belt Idler Flat	231	174573	Strap Torque
47	127783	Pulley, Idler, V-Groove	232	175570	Actuator Cruise Disengage
48	154407	Bellcrank Clutch Grnd Drw Stl	233	174856	Pawl Control Cruise
49	123205X	Retainer, Belt	234	174858	Lever Control Cruise
50	74760624	Bolt	235	174857	Sector Control Cruise
51	73680600	Nut Crownlock 3/8-16 UNC	236	128903	Bolt Shoulder 3/8-16 Unc 1/44
52	73680500	Nut, Crownlock 5/16-18 Unc	237	170165	Bolt Shoulder 5/16-18
53	105710X	Link, Clutch	238	175807	Arm Mtg. Cruise Sector
55	105709X	Spring, Return, Clutch	239	17490508	Screw Thdrol 5/16 x 1/2
56	17060620	Screw 3/8-16 x 1-1/4	240	175610	Spring Return Cruise Control
57	140294	V-Belt, Ground Drive	241	73930400	Nut Centerlock 1/4-20 Unc
59	169691	Keeper, Center Span	242	74780412	Bolt Fin Hex 1/4-20 Unc x 3/4
61	17120614	Screw 3/8-16 x .875	243	178289	Bracket Anti-Rotation CVX
62	123533X	Cover, Pedal	244	166880	Screw 5/16-18 x 5/8 Yellow
63	175417	Pulley, Engine	250	17060612	Screw 3/8-16 x 3/4
65	10040700	Washer	253	179422	Washer .3125 x .615 x 16 Ga.
66	154778	Keeper Belt Engine	254	178062	Clip Retainer
74	137057	Spacer, Axle			
75	121749X	Washer 25/32 x 1-1/4 x 16 Ga.			
76	12000001	E-Ring			

NOTE: All component dimensions given in U.S. inches
1 inch = 25.4 mm

TRACTOR -- MODEL NUMBER 917.272282
STEERING ASSEMBLY

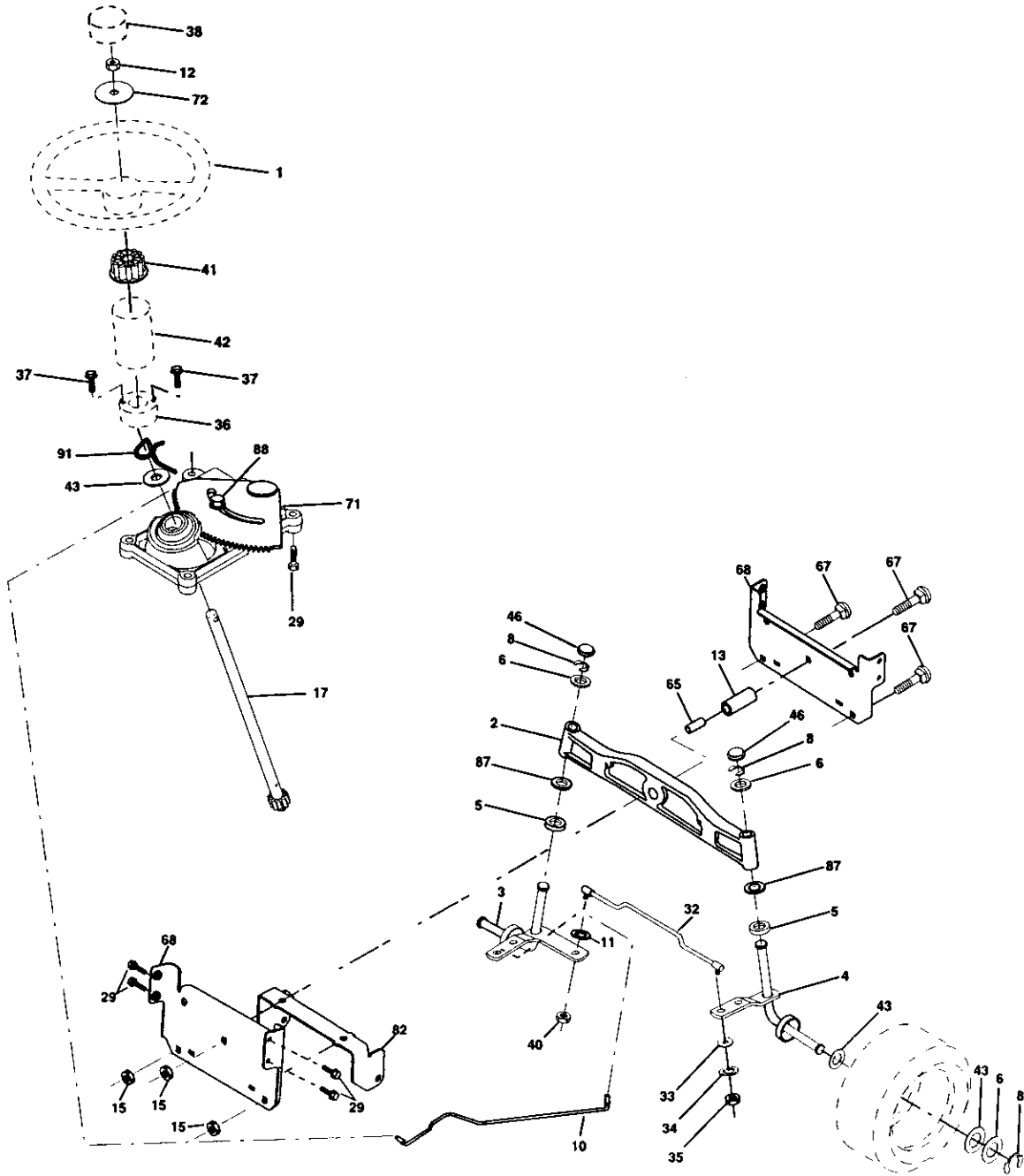

TRACTOR -- MODEL NUMBER 917.272282
STEERING ASSEMBLY

KEY PART NO.	PART NO.	DESCRIPTION
1	175139X418	Steering Wheel
2	172393	Axle Assembly
3	169840	Spindle Assembly, L.H.
4	169839	Spindle Assembly, R.H.
5	6266H	Bearing, Race, Thrust, Hardened
6	121748X	Washer 25/32 x 1-5/8 x 16 Gauge
8	12000029	Ring, Klip
10	175121	Draglink
11	STD551137	Washer, Lock
12	73940800	Nut Hex Jam Toplock 1/2-20 Unf
13	136518	Spacer Brg Axle Front
15	145212	Nut Hexflange Lock
17	177883	Shaft Assembly, Steering
29	17060612	Screw, 3/8-16 x 3/4
32	170162	Rod, Tie
33	19111216	Washer 11/32 x 3/4 x 16 Ga.
34	STD551131	Washer Lock Hvy Spr. 5/16
35	73540500	Crownlock Nut 5/16-24 Unf
36	155105	Bushing, Steering
37	152927	Screw
38	175140X418	Insert, Steering Wheel
40	STD541537	Nut Lock Center 3/8-24 Unf
41	159945	Adaptor, Steering Wheel
42	174530X418	Boot, Steering Shaft
43	121749X	Washer 25/32 x 1-1/4 x 16 Gauge
46	121232X	Cap, Spindle
65	160367	Spacer Brace Axle
67	72140618	Bolt Rdhd Sq 3/8-16 UNC x 2-1/4
68	169827	Axle, Brace
71	175146	Steering Asm
72	19182411	Washer 9/16 Id x 1-1/2 Od 11 G Zin
82	169835	Bracket Susp Chassis Front
87	173966	Washer Flat .781 x 1-1/2 x .14
88	175118	Bolt Shoulder 7/16-20 Unc
91	175553	Clip Steering

NOTE: All component dimensions given in U.S. inches
1 inch = 25.4 mm

TRACTOR -- MODEL NUMBER 917.272282

ENGINE

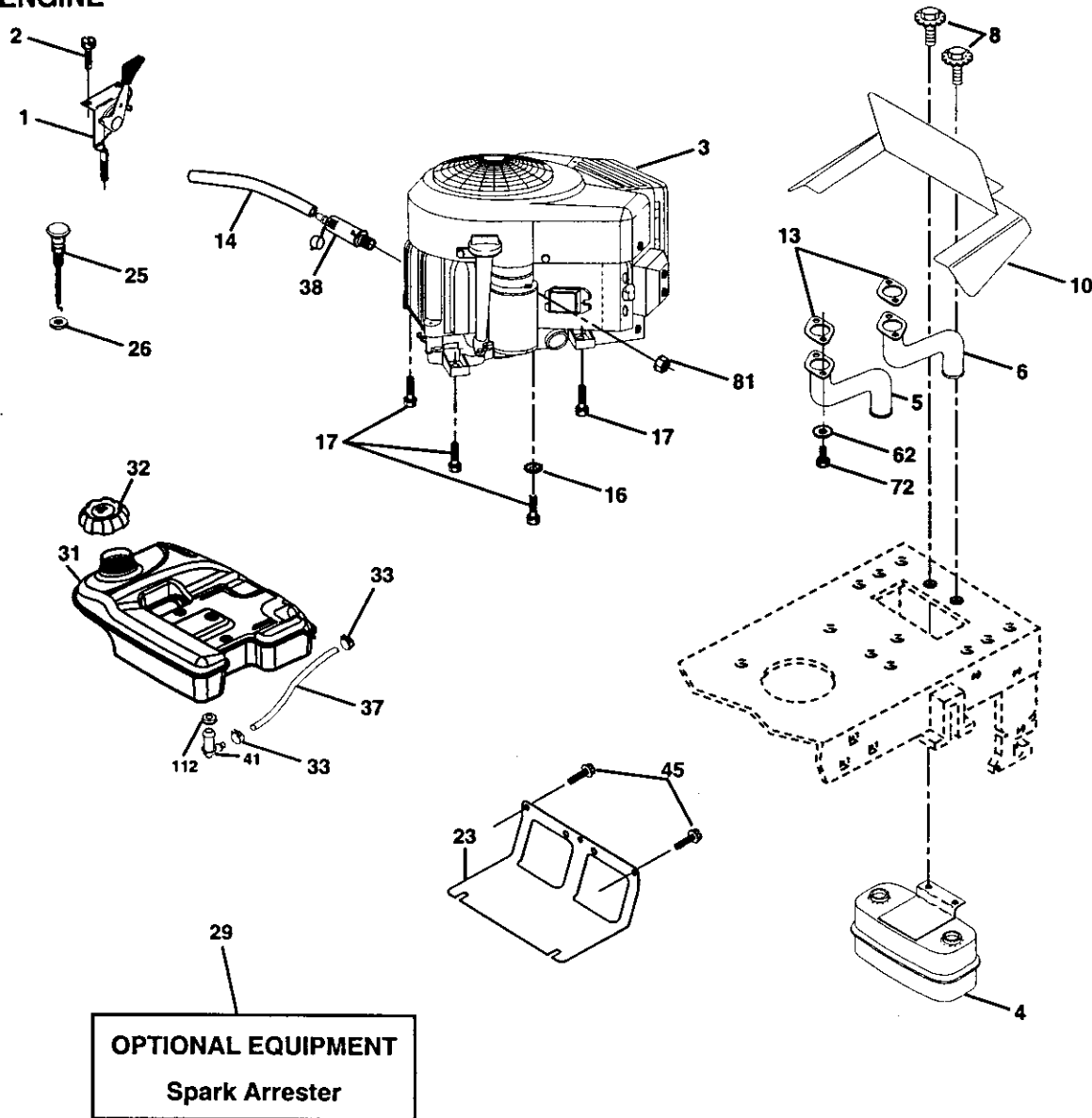

OPTIONAL EQUIPMENT
Spark Arrester

KEY PART NO.	NO.	DESCRIPTION
1	175437X505	Control, Throttle
2	164863	Screw Hwhd H.-Lo #13016 x 3/4
3	-----	Engine, (See Breakdown) B&S Model Number 446777-0165-E1
4	149723	Muffler
5	159955	Pipe Exhaust Lh
6	160589	Pipe Exhaust Rh
8	171877	Bolt 5/16-18 Unc x 3/4
10	162797	Shield Heat
13	165391	Gasket (See Engine Breakdown)
14	148456	Tube Drain Oil Easy
16	11050600	Washer, Lock, Ext. Tooth 3/8
17	17060624	Screw 3/8-16 x 1-1/2
23	169837	Shield, Browning / Debris Guard
25	175440X505	Choke Control
26	73920600	Nut, Keps 3/8-24 Unf
29	137180	Kit, Spark Arrestor

KEY PART NO.	NO.	DESCRIPTION
31	179022	Tank Fuel
32	179124X418	Cap Asm Fuel
33	123487X	Clamp, Hose
37	8543R	Line, Fuel
38	148315	Plug Drain Oil Easy
41	139277	Stem Fuel Tank
45	17000612	Screw Hexwsh Thdr 3/8-16 x 3/4
62	10040500	Washer Lock 5/16
72	71070512	Screw Hex Cap 5/16-18 x 3/4
81	73510400	Nut Keps Hex 1/4-20 UNC
112	3645J	Bushing

NOTE: All component dimensions given in U.S. inches
1 inch = 25.4 mm

TRACTOR -- MODEL NUMBER 917.272282

SEAT ASSEMBLY

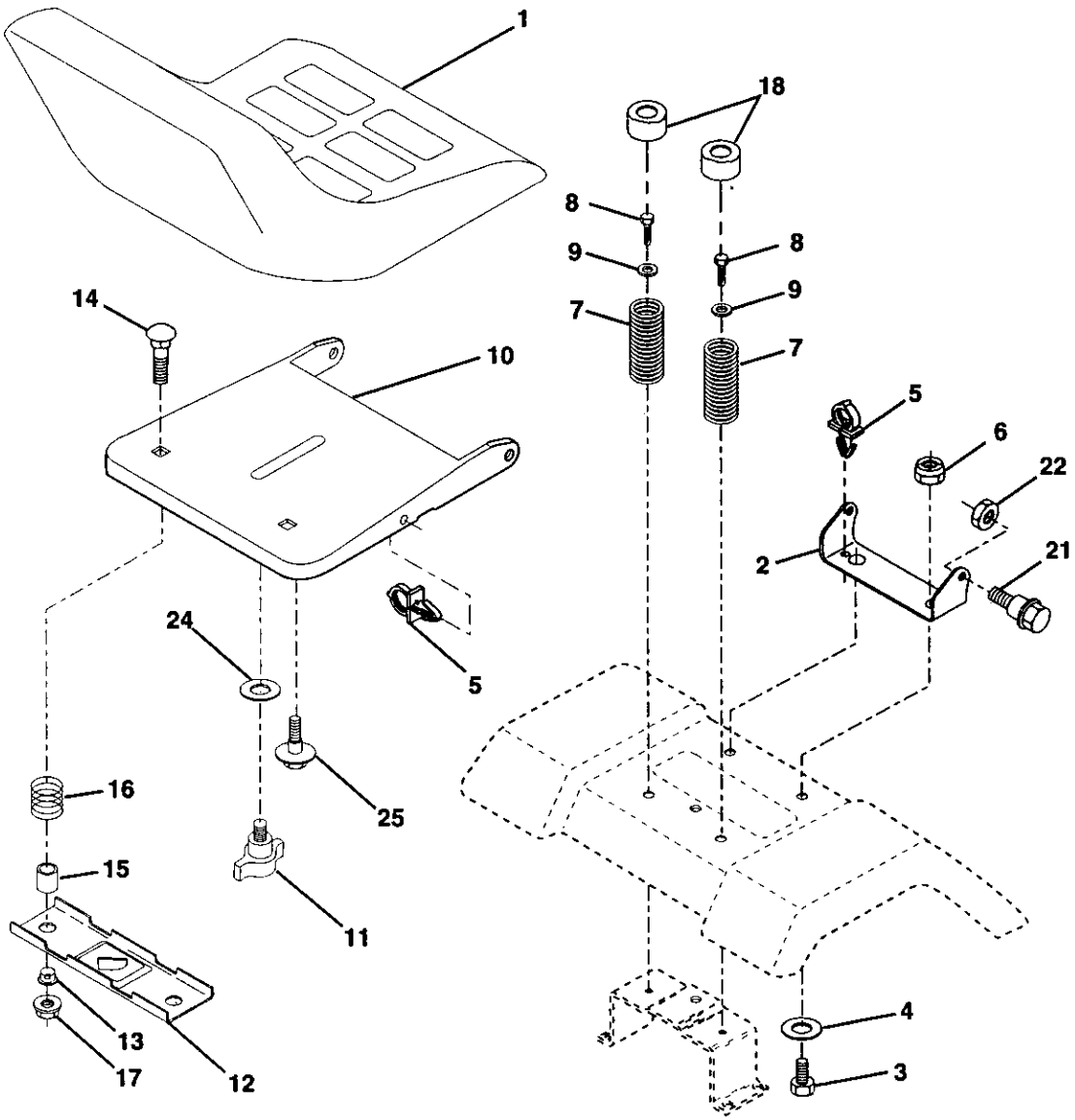

KEY PART NO.	NO.	DESCRIPTION
1	175134	Seat
2	140551	Bracket, Pivot, Seat
3	71110616	Bolt
4	19131610	Washer 13/32 x 1 x 10 Gauge
5	145006	Clip, Push-In Hinged
6	STD541437	Nut
7	124181X	Spring, Seat
8	17000616	Screw 3/8-16 x 1-1/2
9	19131614	Washer 13/32 x 1 x 14 Gauge
10	182493	Pan, Seat
11	177957	Knob Seat
12	121246X	Bracket, Switch Mounting
13	121248X	Bushing, Snap

KEY PART NO.	NO.	DESCRIPTION
14	72050412	Bolt, Carriage 1/4-20 x 1-1/2
15	121249X	Spacer, Split
16	123740X	Spring
17	123976X	Locknut, Flange 1/4 Grade 5
18	124238X	Cap Spring Seat
21	171852	Bolt, Shoulder 5/16-18 UNC
22	STD541431	Nut
24	19171912	Washer 17/32 x 1-3/16 x 12 Gauge
25	127018X	Bolt, Shoulder 5/16-18 x .62

NOTE: All component dimensions given in U.S. inches
1 inch = 25.4 mm

TRACTOR -- MODEL NUMBER 917.272282

DECALS

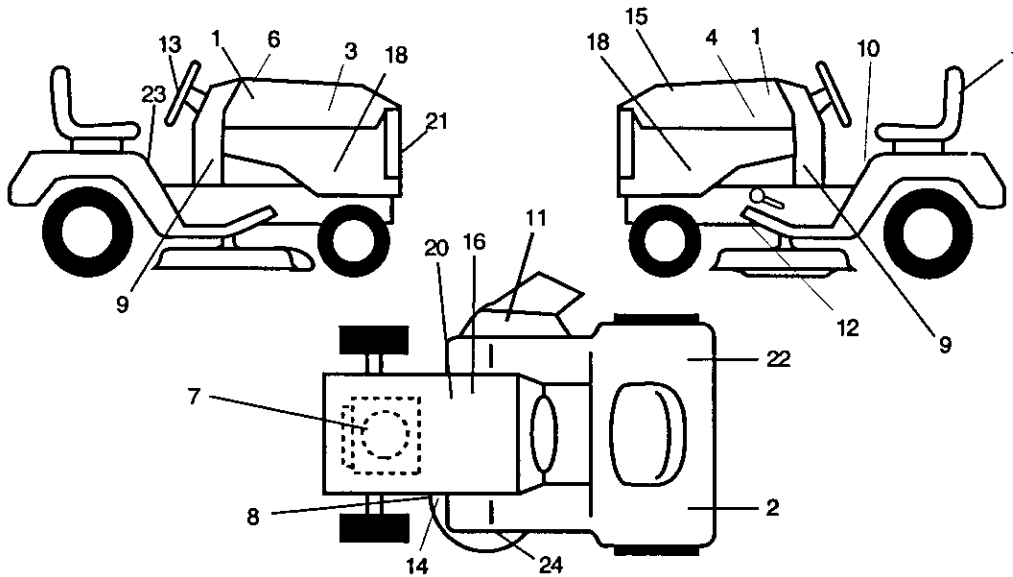

KEY PART NO. NO.

KEY PART NO.	NO.	DESCRIPTION
1	180978	Decal, Hood/Seat
2	174969	Reflector L.H.
3	177909	Decal, Hood, R.H.
4	177910	Decal, Hood, L.H.
6	133644	Decal, Customer Maintenance
7	181604	Decal, Engine
8	179128	Decal, Deck B 42
9	182168	Decal, Dash Lwr
10	156439	Decal, Fender Danger
11	181470	Decal, Deck Leveling
12	146046	Decal, V-Belt Drive Schematic
13	177890	Decal Strg Wheel
14	160396	Decal, V-Belt Schematic

KEY PART NO. NO.

KEY PART NO.	NO.	DESCRIPTION
15	181427	Decal Repic
16	138047	Decal, Battery Diehard
18	177913	Decal, Panel Side
20	149516	Decal, Battery Dngr/Psn Eng
21	177889	Decal, Grille
22	174970	Reflector RH
23	177955	Decal, Fender Oper Cruise
24	172331	Decal, Deck
--	138311	Decal, Lift Handle
--	174998X418	Pad Footrest LH
--	175542X418	Pad Footrest RH
--	169210	Decal, By Pass Lt Hydro
--	183252	Owner's Manual, English
--	183253	Owner's Manual, Spanish

WHEELS & TIRES

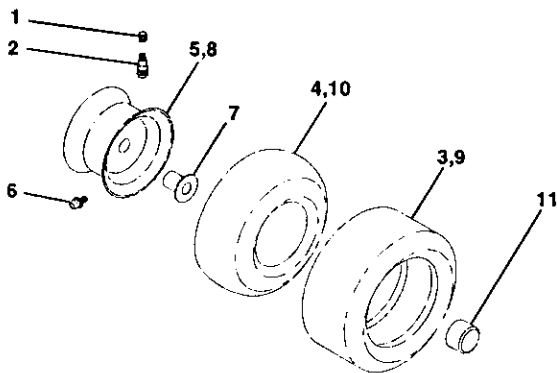

KEY PART NO. NO.

KEY PART NO.	NO.	DESCRIPTION
1	59192	Valve Cap, Tire
2	65139	Stem, Valve
3	177750	Tire, Front
4	59904	Tube, Front Tire (Not Provided, Service Item Only)
5	106732X417	Rim, Front
6	278H	Fitting, Grease (Front Wheel Only)
7	9040H	Bearing, Flange (Front Wheel Only)
8	106108X417	Rim, Rear
9	177751	Tire, Rear
10	7152J	Tube, Rear Tire (Not Provided, Service Item Only)
11	104757X417	Cap, Axle
--	144334	Sealant, Tire 10 oz.

NOTE: All component dimensions given in U.S. inches
1 inch = 25.4 mm

TRACTOR -- MODEL NUMBER 917.272282

LIFT ASSEMBLY

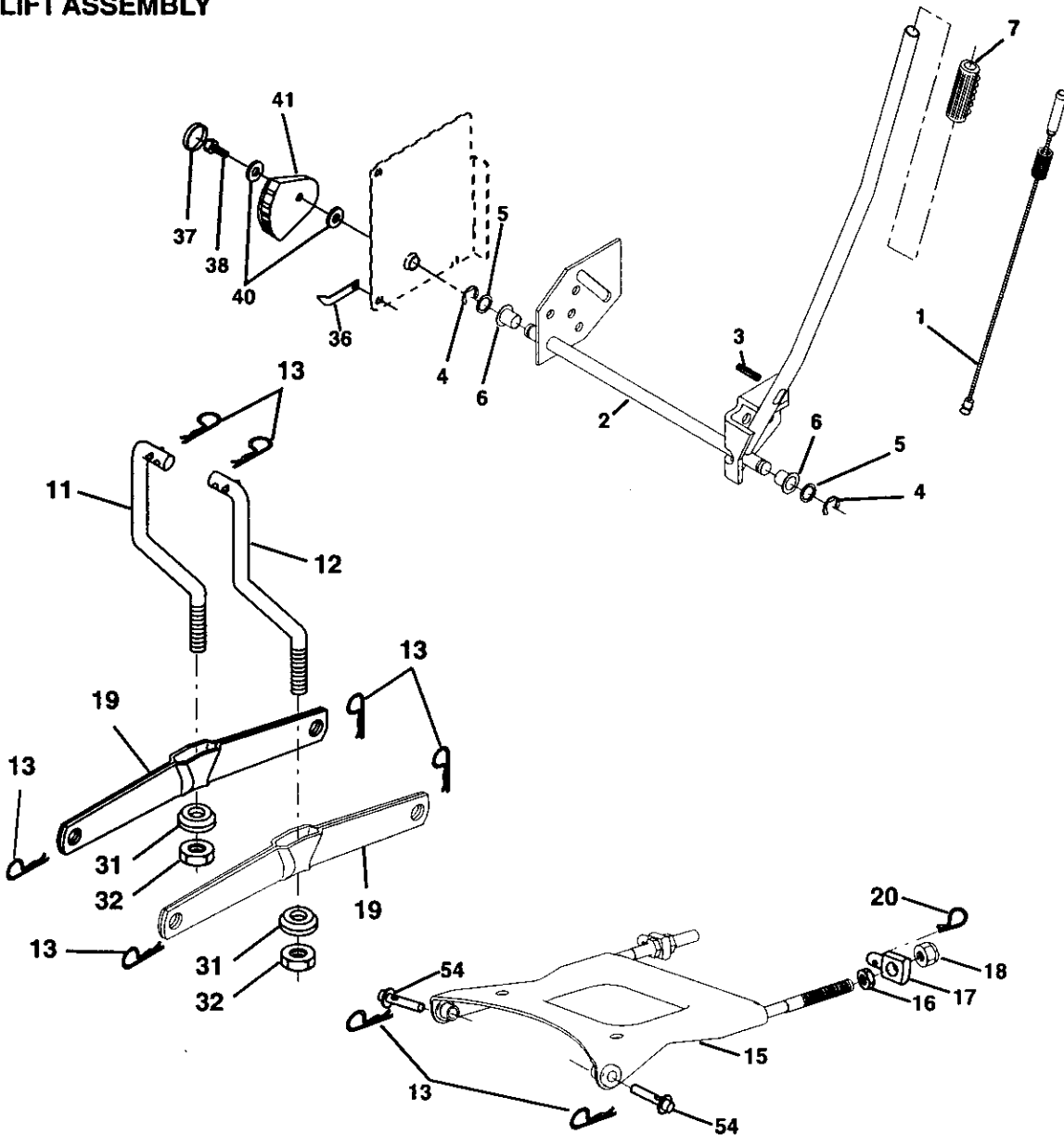

KEY PART NO. NO.

KEY PART NO.	NO.	DESCRIPTION
1	179504	Plunger Assembly
2	159476	Shaft Assembly, Lift
3	178981	Pin, Groove
4	12000002	E-Ring
5	19211621	Washer 21/32 x 1 x 21 Gauge
6	120183X	Bearing, Nylon
7	175830	Grip, Handle, Fluted
11	139865	Link, Lift, L.H.
12	139866	Link, Lift, R.H.
13	4939M	Retainer Spring
15	175562	Plate Asm Suspension Front
16	73350800	Nut Jam Hex 1/2-13 Unc
17	175689	Trunnion Front Susp.
18	73800800	Nut Lock w/Wsh 1/2-13 Unc
19	139868	Arm Asm. Suspension Mower

KEY PART NO. NO. DESCRIPTION

KEY PART NO.	NO.	DESCRIPTION
20	163552	Retainer Spring
31	169865	Trunion Sups. Arm. Bearing Pivot
32	73540600	Nut Crownlock 3/8-24
36	155097	Pointer Height Indicator
37	123935X	Plug Hole
38	17060516	Screw 5/16-18 x 1
40	19112410	Washer 11/32 x 1-1/2 x 10 Ga
41	155098	Indicator Height Still
54	175560	Pin Flange

NOTE: All component dimensions given in U.S. inches
1 inch = 25.4 mm

TRACTOR -- MODEL NUMBER 917.272282

MOWER DECK

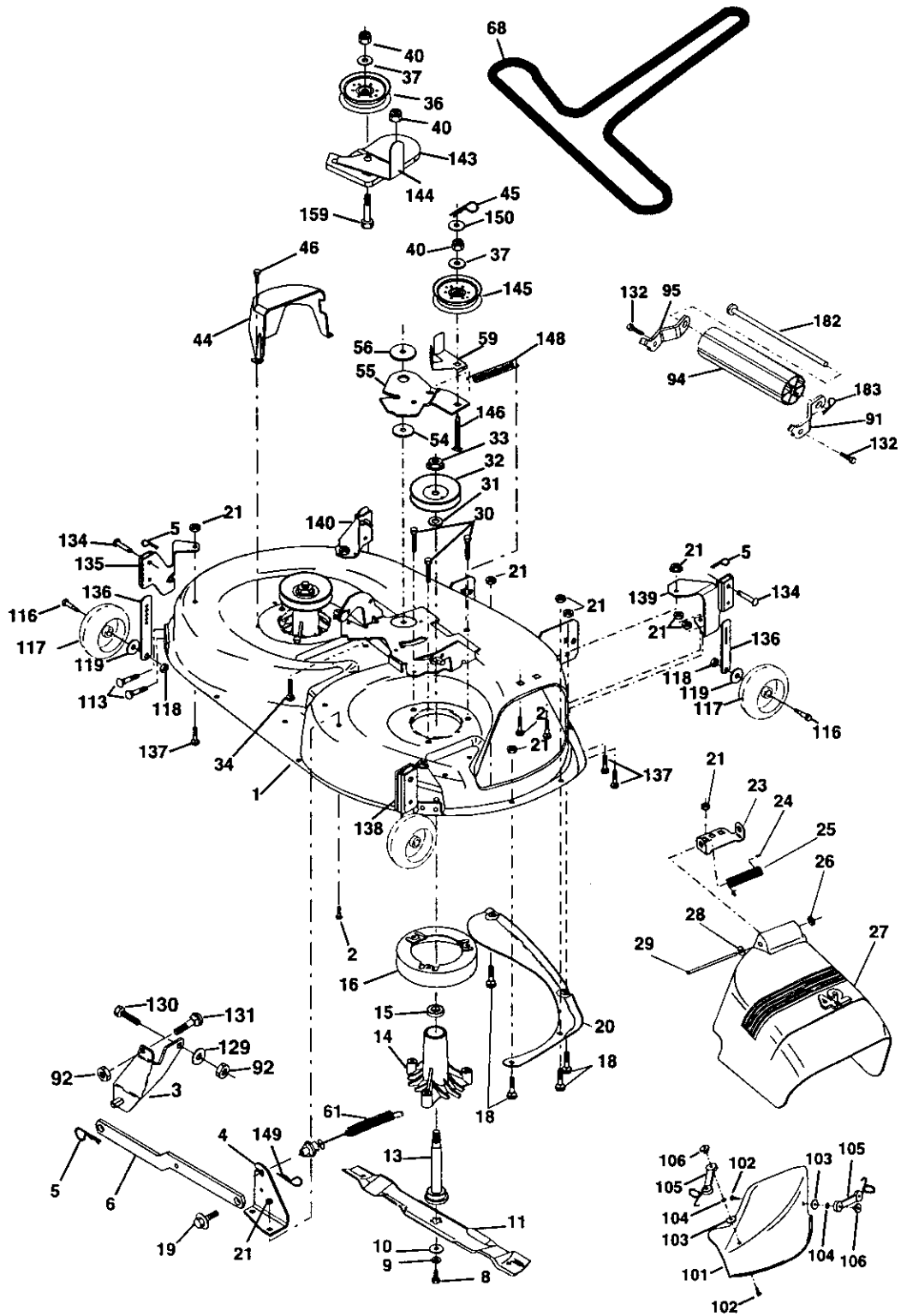

TRACTOR -- MODEL NUMBER 917.272282

MOWER DECK

KEY PART NO.	NO.	DESCRIPTION	KEY PART NO.	NO.	DESCRIPTION
1	182032	Mower Deck Assembly, 42"	68	174883	V-Belt
2	STD533107	Bolt	91	180532	Bracket Roller Nose LH
3	138017	Bracket Assembly, Sway Bar, Front	92	STD541437	Nut
4	165460	Bracket Sway Bar 38/42" Deck	94	132264	Roller Nose 38-50
5	STD624008	Retainer Spring	95	180533	Bracket Roller Nose RH
6	178024	Bar Sway Deck	101	136420	Mulcher Cover
8	850857	Bolt, Hex 3/8-24 x 1.25 Gr. 8	102	71081010	Screw
9	STD551137	Washer, Lock	103	19061216	Washer #10
10	140296	Washer, Hardened	104	STD551110	Washer, Lock
11	139775	Blade, Mulching Premium	105	160793	Latch Assembly, Bagger
13	137645	Shaft Assembly, Mandrel, Vented	106	2029J	Nut, Weld
14	128774	Housing, Mandrel, Vented	116	4898H	Bolt shoulder
15	110485X	Bearing, Ball, Mandrel	117	165746	Wheel Gauge Rally
16	174493	Stripper, Vented Mower Deck	118	73930600	Nut Centerlock 3/8-16
17	72110614	Bolt Rdhd 3/8-16 x 1-3/4 x Gr. 5	119	19121414	Washer 3/8 x 7/8 x 14 Ga.
18	72140505	Bolt, Carriage 5/16-18 x 5/8	129	19131312	Washer 13/32 x 13/16 x 12 Ga.
19	132827	Bolt, Shoulder	130	STD523710	Bolt, Fin Hex 3/8-16 UNC x 1 Gr.5
20	159770	Baffle, Vortex	131	STD533710	Bolt, Rdhd Sqnk 3/8-16UNC x 1
21	STD541431	Nut Crownlock 5/16-18 UNC	132	17060612	Screw 3/8-16 x 3/4
23	177563	Bracket, Deflector	134	156941	Pin Head Rivet
24	105304X	Cap, Sleeve	135	155989	Bracket Whl. Gauge Rear LH
25	123713X	Spring, Torsion, Deflector	136	155986	Channel Adj. Whl Gauge
26	110452X	Nut, Push	137	72110505	Bolt Carr Short 5/16-18 x 5/8
27	130968X428	Shield, Deflector	138	155992	Bracket Whl. Gauge Rear RH
28	19111016	Washer 11/32 x 5/8 x 16 Ga.	139	159644	Bracket Whl Gauge Front RH
29	131491	Rod, Hinge	140	159643	Bracket Whl Gauge Front LH
30	173984	Screw Thd Roll Dod Pt. Hex	143	157109	Bracket Arm Idler 42"
31	129963	Washer, Spacer	144	158634	Keeper Belt 42" Clutch Cable
32	153535	Pulley, Mandrel	145	165888	Pulley Idler Flat
33	178342	Nut, Toplock, Flanged	146	171977	Bolt Carriage Idler
36	131494	Pulley, Idler, Flat	148	169022	Spring Return Idler
37	STD551037	Washer 13/32 x 13/16 x 16 Ga.	149	165898	Retainer Spring Yellow Zinc
40	STD541437	Nut Crownlock 3/8-16 UNC	150	19091216	Washer 9/32 x 3/4 x 16 Ga.
44	140088	Guard, Mandrel, L.H.	159	72140614	Bolt Tdhd Sgn 3/8-16UNC x 1-3/4
45	STD624003	Retainer	182	179126	Rod Roller Nose
46	137729	Screw, Thd. Roll 1/4-20 x 5/8	183	163552	Retainer Spring Zinc
54	133943	Washer, Hardened	--	130794	Mandrel Assembly (Includes Housing, Shaft and Shaft Hardware Only - Pulley Not Included)
55	155046	Arm, Idler	--	181542	Replacement Mower, Complete
56	165723	Spacer, Retainer			
59	141043	Guard, TUV Idler			
61	174882	Spring Ext. Elect Clutch			

NOTE: All component dimensions given in U.S. inches
1 inch = 25.4 mm

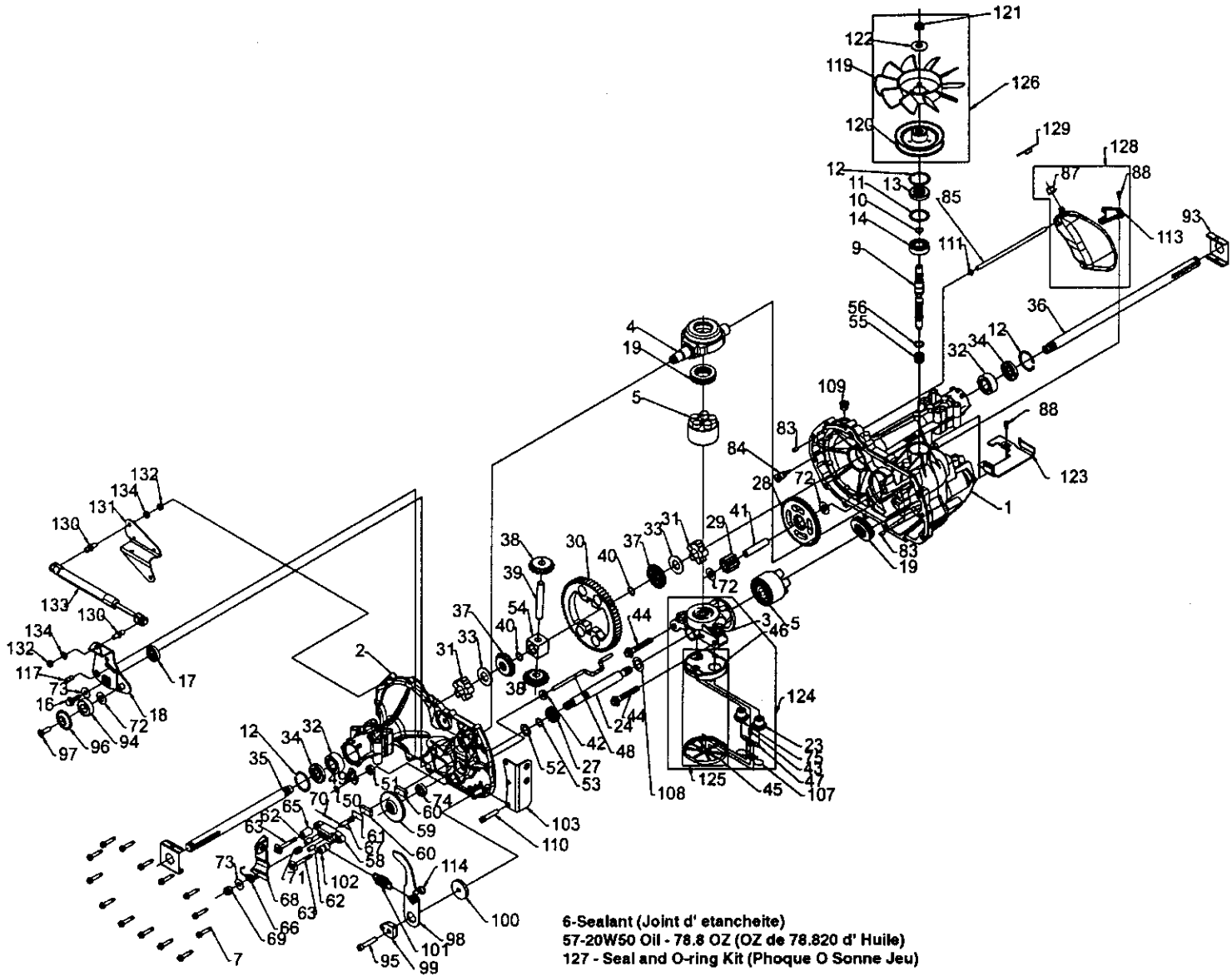

TRACTOR -- MODEL NUMBER 917.272282
 HYDRO GEAR TRANSAXLE -- MODEL NUMBER 336-0510

TRACTOR -- MODEL NUMBER 917.272282
HYDRO GEAR TRANSAXLE -- MODEL NUMBER 336-0510

KEY PART NO.	NO.	DESCRIPTION	KEY PART NO.	NO.	DESCRIPTION
1	170351	Main Housing, Assembly	67	170413	Sq. Hd. Bolt 5/16-24-Ribbed
2	170352	Side Housing, Assembly	68	178782	Arm, Brake
3	170353	Center Section, Assembly	69	170415	Slotted Hex Nut 5/16-24
4	170354	Swashplate, Trunion Machined	70	170416	Cotter Pin 3/32 X 3/4
5	169898	Block - Assembly	71	170417	Compression Spring Brake Anti-Drag
6	170355	Sealant 10.5 Oz			
7	170356	Hex Flange Screw 1/4-20 X 1.25	72	170418	Washer, Ht .5 I.D. X 1 O.D. X .032
8	170357	Stud, 5/16-24 Hex Double End			
9	170358	Shaft, Input	73	142884	Flat - Washer 11/32 I.D. X 7/8 Od
10	170359	Ring - Retaining	74	170419	Oil Seal .625 X 1.0 X .25
11	170360	Spacer	75	170420	Check Plug Assembly, .027, Washer
12	169870	Ring - Retaining			
13	170361	Seal, Lip .67 X 1.58 X .276	76	170421	Stud, 5/16-24 Friction Pack
14	169869	Ball Brg 17mm Id X 40mm Od X 12mm	77	170422	Puck, .330 X 1.50 X .0975
			78	142969	Spring, Helical Comp
16	170362	Hex Flange Head Screw 5/16-24X0.75	79	142980	Spacer
			80	150778	Hex Lock Nut 5/16-24Unjif(Nylon Insert)
17	170363	Lip Seal 18 X 32 X 7			
18	178781	Arm, Control	81	170423	Wedge, Friction Pack
19	150771	Bearing, 30x52x13 Thrust	82	170424	Clip, Washer .316x1.50x.1046 (Plated)
23	170365	Check Plug Assembly, Washer			
24	170366	Shaft, Motor	83	161168	Pin, Standard Headless
27	170367	Gear - Pinion, 13t	84	170425	Fitting, 5/16 Sae 5/32 Tube
28	170368	10t/48t Gear	85	170426	Hose, Expansion Tank
29	170369	Gear, 10t Jackshaft	87	142917	Cap - Poppet Valve
30	170370	60t Bull Gear	88	170429	Bolt, Self Tapping 10-32 X 1/2
31	170371	Sleeve Bearing .75 X 1.575 X .625	90	170430	Puck, Inner Wedge
			93	170431	Spring Clip - Housing Thrust
32	170389	SleeveBearing(Outboard) .75x1.750x.625	94	178783	Bearing, Ball
			95	178784	Screw, Socket Head Cap 5/16-24X1-1/2
33	142991	Washer, 3/4 Id X 1-1/2 Od X .13 Thk	96	178786	Spacer, Locating
			97	178787	Screw, SFHCS 5/16-18 X1
34	170390	Lip Seal Axle Seal	98	178789	Arm Return
35	170391	Shaft, Axle .75 X 11.39(Key,R.H.)	99	178792	Puck, Adjusting
36	170392	Shaft, Axle .75 X 16.99 (Key,L.H.)	100	178793	Washer, .24 ID X 1.60 OD X .239
37	150792	Miter Gear (Splined)	101	178794	Spring, Extension
38	150793	Miter Gear 15t (0.5 Id)	102	178795	Spacer .260 ID X .560 OD X .870
39	150809	Shaft	103	178796	Bracket, Torque
40	170393	Ring, Spiral Retaining	107	170432	Deflector
41	170394	Pin, Jackshaft	108	170433	Washer, Motor Shaft
42	170395	Magnet, Ring			
43	170396	Spring, Bypass	109	170434	.71idx1.150dx.030thk
44	150797	Hydro Mtg Screw 3/8-24 X 2.5 Lg	111	170435	Plug, Sae #6
45	170397	Filter	113	170437	O-Ring .07 X .301 I.D.
46	170398	Base, Filter	114	178797	Bracket, Support Expansion Tank
47	170399	Actuator, Bypass	116	170438	Spring
48	170400	Rod, Bypass Actuator	117	178799	Silicon Sponge
49	170401	Arm, Bypass	119	170439	Pin, Spring
50	170402	Retaining Ring .250 External	120	170440	Fan, 7 In.
51	170403	Seal, Lip .741 X .250 X .250 Tc	121	170441	Pulley
52	170404	Flat Washer, 5/8Id x 1.0 Od x .05 Thk	122	170442	Hex Lock Nut 1/2-20 (Nylon Ins.)
			123	178800	Washer, Belleville
53	170405	Retaining Ring	124	170444	Belt Keeper
54	170406	Bearing, Center Block	125	170445	Center Section-Filter-Bypass Asm.
55	142977	Spring - Helical Compression	126	170446	Filter Assembly
56	142978	Washer	127	170447	Fan - Pulley Service Assembly
57	150798	20w-50 Oil	128	173165	Seal - O-Ring Kit
58	170407	Brake Yoke	130	178802	Kit, Expansion Tank
59	170408	Rotor, Brake	131	178803	Stud Ball
60	142883	Brake Puck	132	178804	Bracket, Cruise Damper
61	142882	Puck Plate	133	178806	Hex Nut 5/16-18 NC
62	142887	Brake Actuating Pin	134	178808	Damper
63	170410	Hfhcs 1/4-20x2 W/ Patch,SpecialFlange	900	173839	Washer, Helical Spring Lock 5/16 Transaxle Complete
64	142892	Bolt, 1/4-20 X 1 W/Patch			
65	170411	Spacer			
66	170412	Spring, Brake Arm Bias			

NOTE: All component dimensions given in U.S. inches
1 inch = 25.4 mm

TRACTOR -- MODEL NUMBER 917.272282
BRIGGS & STRATTON ENGINE-MODEL NUMBER 446777 TYPE NUMBER 0165-E1

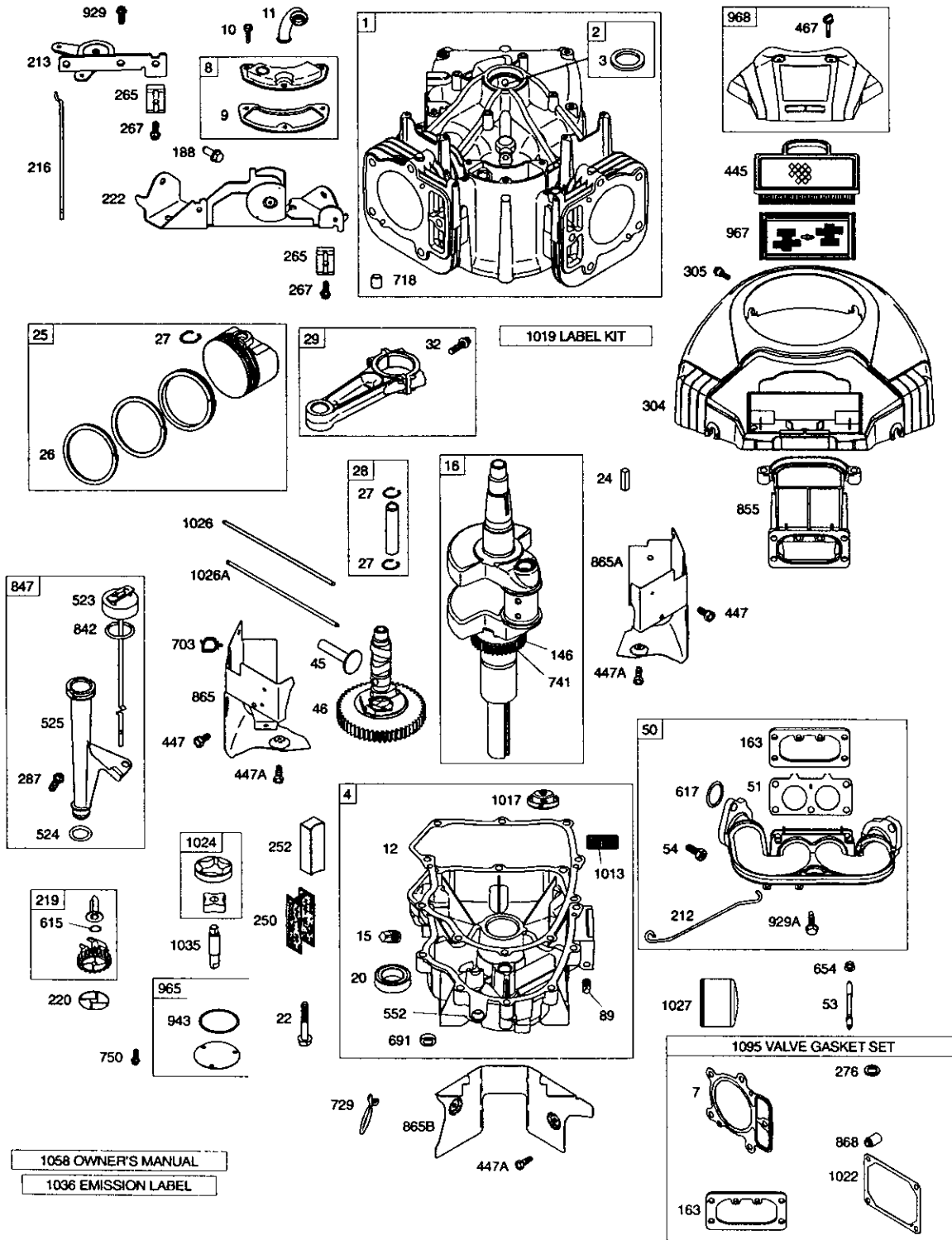

**TRACTOR -- MODEL NUMBER 917.272282
BRIGGS & STRATTON ENGINE-MODEL NUMBER 446777 TYPE NUMBER 0165-E1**

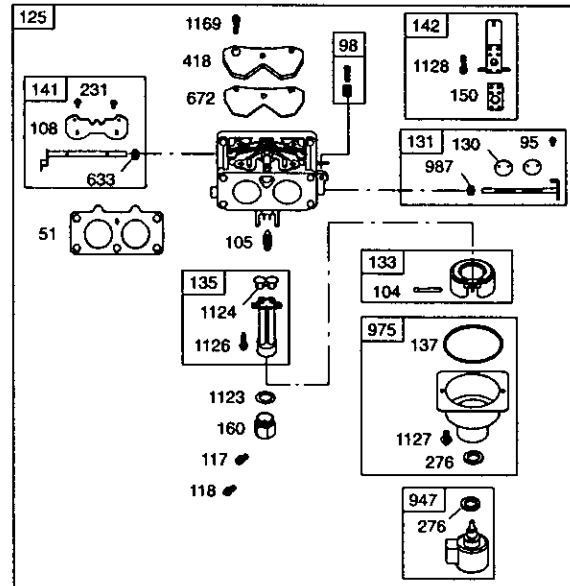
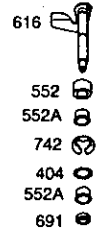
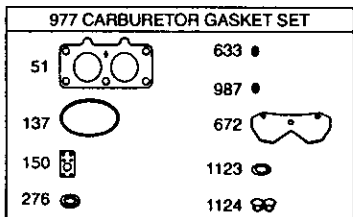
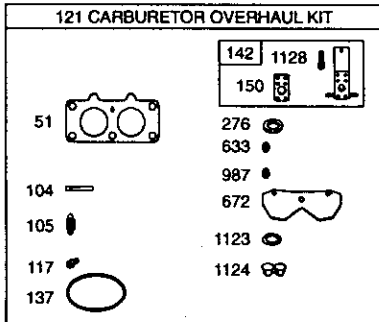
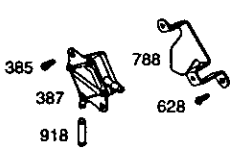
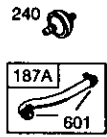
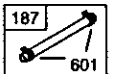
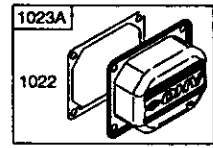
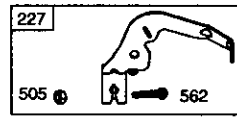
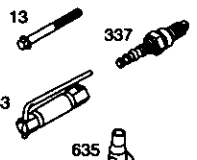
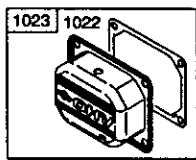
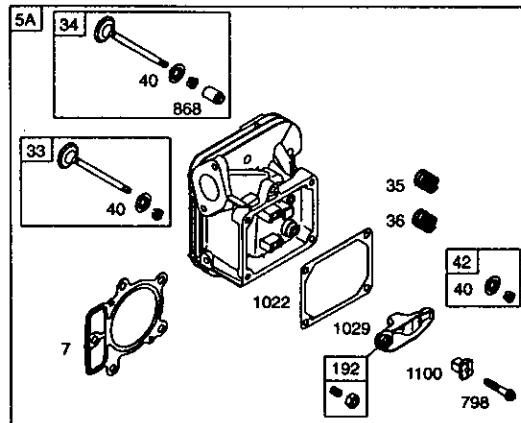
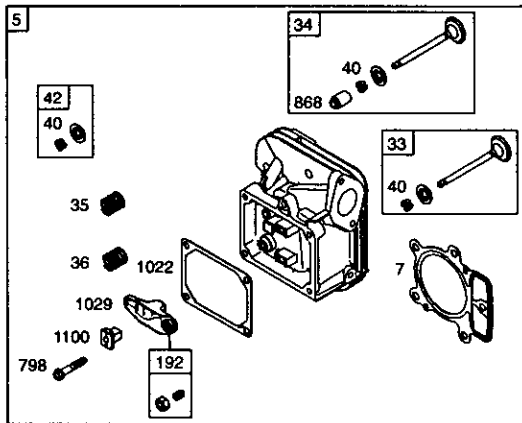

TRACTOR -- MODEL NUMBER 917.27282
BRIGGS & STRATTON ENGINE-MODEL NUMBER 446777 TYPE NUMBER 0165-E1

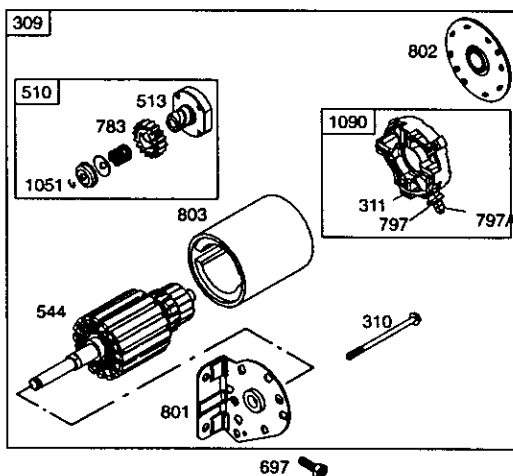
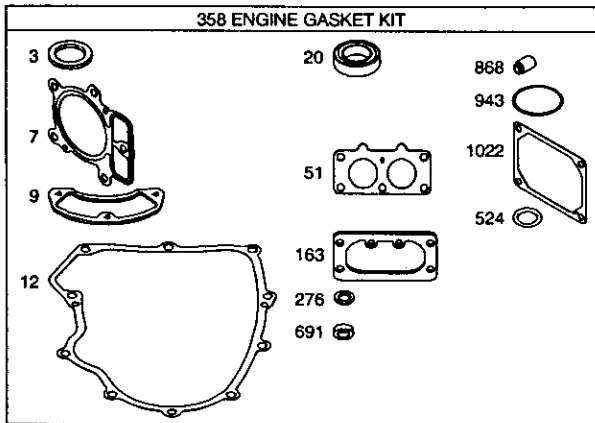
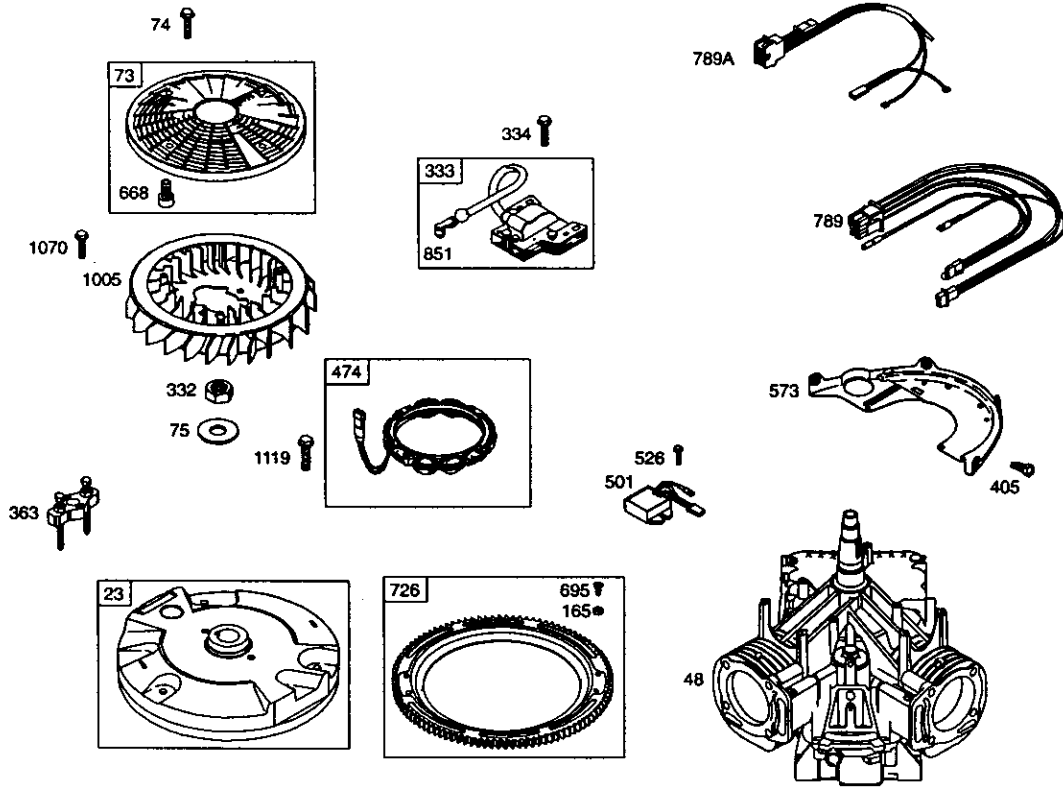

TRACTOR -- MODEL NUMBER 917.272282
BRIGGS & STRATTON ENGINE-MODEL NUMBER 446777 TYPE NUMBER 0165-E1

KEY NO.	PART NO.	DESCRIPTION	KEY NO.	PART NO.	DESCRIPTION
1	694001	Cylinder Assembly	117	690232	Ø Jet-Main (Standard)
2	499585	Kit-Bushing/Seal (Magneto Side)	118	690989	Jet-Main (High Altitude)
3	391086	• Seal-Oil (Magneto Side)	121	499811	Kit-Carburetor Overhaul
4	690069	Sump-Engine	125	499804	Carburetor
5	697580	Head-Cylinder (Cylinder 1)	130	690993	Valve-Throttle
5A	697581	Head-Cylinder (Cylinder 2)	131	499805	Kit-Throttle Shaft
7	693997	•+ Gasket-Cylinder Head	133	499806	Float-Carburetor
8	499601	Breather Assembly	135	499803	Tube-Fuel Transfer
9	690937	• Gasket-Breather	137	690994	Ø‡ Gasket-Float Bowl
10	690960	Screw (Breather Assembly)	141	499807	Kit-Choke Shaft
11	690942	Tube-Breather	142	499808	Ø Nozzle-Carburetor
12	697227	• Gasket-Crankcase	146	690979	Key-Timing
13	690360	Screw (Cylinder Head)	150	690995	Ø‡ Gasket-Nozzle
15	690946	Plug-Oil Drain	160	690996	Retainer-Solenoid
16	691046	Crankshaft	163	691001	•+ Gasket-Air Cleaner
20	690947	• Seal-Oil (PTO Side)	165	693148	Nut (Ring Gear)
22	694966	Screw (Engine Sump)	187	691050	Line-Fuel (Cut to Required Length)
23	691053	Flywheel	187A	691049	Line-Fuel (Molded)
24	222698	Key-Flywheel	188	690960	Screw (Control Bracket)
25	697679	Piston Assembly (Standard)	192	690083	Adjuster-Rocker Arm
25	697680	Piston Assembly (.010" Oversize)	209	697674	Spring-Governor
25	697681	Piston Assembly (.020" Oversize)	211	691019	Spring-Governed Idle
25	697682	Piston Assembly (.030" Oversize)	212	695238	Link-Throttle
26	697683	Ring Set-Piston (Standard)	213	691021	Bracket-Choke Control
26	697684	Ring Set-Piston (.010" Oversize)	216	691022	Link-Choke
26	697685	Ring Set-Piston (.020" Oversize)	219	696376	Gear-Governor
26	697686	Ring Set-Piston (.030" Oversize)	220	690412	Washer (Governor Lever)
27	690975	Lock-Piston Pin	222	691023	Bracket-Control
28	690229	Pin-Piston	227	691048	Lever-Governor Control
29	499583	Rod-Connecting	231	690718	Screw (Choke Valve)
32	690976	Screw (Connecting Rod)	240	695666	Filter-Fuel
33	697576	Valve-Exhaust	250	690957	Retainer-Breather
34	499597	Valve-Intake	252	690956	Collector-Oil
35	690963	Spring-Valve (Intake)	265	691024	Clamp-Casing
36	690963	Spring-Valve (Exhaust)	267	695134	Screw (Casing Clamp)
40	690964	Retainer-Valve	276	690997	•Ø+ Washer-Sealing
42	499586	Keeper-Valve	287	690960	Screw (Dipstick Tube)
45	690977	Tappet-Valve	304	695277	Housing-Blower
46	690978	Camshaft	305	691005	Screw (Blower Housing)
48	692714	Short Block (446777-0027-E2 Replacement Engine)	309	691262	Motor-Starter
50	695241	Manifold-Intake	310	691263	Bolt-Starter Motor
51	690950	• Ø‡ Gasket-Intake	311	497608	Brush Set
53	690951	Stud (Carburetor)	332	691059	Nut (Flywheel)
54	695240	Screw (Intake Manifold)	333	691060	Armature-Magneto
73	691055	Screen-Rotating	334	691061	Screw (Magneto Armature)
74	691057	Screw (Rotating Screen)	337	491055	Spark Plug
75	691056	Washer (Flywheel)	358	694012	Set-Engine Gasket
89	690283	Plug-Oil			
95	690718	Screw (Throttle Valve)			
98	499802	Kit-Idle Speed			
104	690984	Ø Pin-Float Hinge			
105	690985	Ø Valve-Float Needle			
108	690986	Valve-Choke			

RPM Settings: Low Speed: 1900-2100
High Speed: 3000-3200

- Included in Engine Gasket Set, Key. No. 358
- Ø Included in Carburetor Overhaul Kit, Key. No. 121
- ‡ Included in Carburetor Gasket Set, Key. No. 977
- + Included in Valve Gasket Set, Key. No. 1095

NOTE: All component dimensions given in U.S. inches 1 inch = 25.4 mm

TRACTOR -- MODEL NUMBER 917.272282
BRIGGS & STRATTON ENGINE-MODEL NUMBER 446777 TYPE NUMBER 0165-E1

KEY NO.	PART NO.	DESCRIPTION	KEY NO.	PART NO.	DESCRIPTION
363	691062	Flywheel Puller	842	691031	• Seal-Dipstick/Tube
383	690966	Wrench-Spark Plug	847	499602	Dipstick/Tube Assembly
385	690960	Screw (Fuel Pump)	851	493880	Terminal-Sparkplug
387	808656	Pump-Fuel	855	691011	Adapter-Air
404	690442	Washer (Governor Crank)	865	691012	Cover-Air Guide
405	690960	Screw (Back Plate)	865A	691014	Cover-Air Guide
418	690999	Plate-Carburetor	865B	691015	Cover-Air Guide
445	695667	Filter-Air Cleaner Cartridge	868	690968	•+ Seal-Valve
447	691003	Screw (Air Guide Cover)	914	691127	Screw (Rocker Cover)
447A	690960	Screw (Air Guide Cover)	918	694000	Hose-Vacuum
467	691008	Knob-Air Cleaner	929	695239	Screw (Choke Control Bracket)
474	696458	Alternator	929A	691003	Screw (Choke Control Bracket)
501	691185	Regulator	943	690589	• Seal-O Ring (Oil Pump Cover)
505	691029	Nut (Governor Control Lever)	947	499809	Solenoid-Fuel
510	497606	Drive-Starter	965	499613	Cover-Oil Pump
513	692024	Clutch-Drive	967	272638	Filter-Pre Cleaner
523	691036	Dipstick	968	499788	Cover-Air Cleaner
524	691032	• Seal-Dipstick Tube	975	499810	Bowl-Float
525	691037	Tube-Dipstick	977	499812	Gasket Set-Carburetor
526	690960	Screw (Regulator)	987	691000	Ø ‡ Seal-Throttle Shaft
544	-----	Armature-Starter (Service with 691262 Starter Motor)	1005	499603	Fan-Flywheel
552	690552	Bushing-Governor Crank	1013	690954	Nipple-Oil Filter
552A	690553	Bushing-Governor Crank	1017	690770	Screen-Oil Pump
562	690311	Bolt (Governor Control Lever)	1019	690103	Kit-Label
573	691009	Plate-Back	1022	690971	•+ Gasket-Rocker Cover
601	691038	Clamp-Hose	1023	499599	Cover-Rocker (Cylinder 1)
615	690317	Retainer-Governor Shaft	1023A	499600	Cover-Rocker (Cylinder 2)
616	691045	Crank-Governor	1024	499054	Pump-Oil
617	691917	Seal-O Ring (Intake Manifold)	1026	690981	Rod-Push (Steel)
628	690960	Screw (Fuel Pump Bracket)	1026A	690982	Rod-Push (Aluminum)
633	690998	Ø ‡ Seal-Choke/Throttle Shaft	1027	696854	Filter-Oil
635	66538	Boot-Sparkplug	1029	690972	Arm-Rocker
654	690958	Nut (Carburetor)	1035	691042	Shaft-Pump
668	691215	Spacer	1036	695704	Label-Emission
672	690234	Ø ‡ Gasket-Carburetor Plate	1051	691265	Ring-Retaining
691	690657	• Seal-Governor Shaft	1058	274794	Owner's Manual
695	693149	Screw (Ring Gear)	1070	691058	Screw (Flywheel Fan)
697	690372	Screw (Drive Cap)	1090	691293	Retainer-Brush
703	691010	Clip	1095	694013	Gasket Set-Valve
718	690959	Pin-Locating	1100	690973	Pivot-Rocker Arm
726	499612	Gear-Ring	1119	691183	Screw (Alternator)
729	694123	Clip-Wire	1123	690987	Ø ‡ Seal-O Ring (Solenoid Retainer)
741	690980	Gear-Timing	1124	690988	Ø ‡ Seal-O Ring (Fuel Transfer Tube)
742	690328	Retainer-E Ring	1126	690991	Screw (Fuel Transfer Tube)
750	696999	Screw (Oil Pump Cover)	1127	690992	Screw (Float Bowl)
783	693058	Gear-Pinion	1128	690990	Ø Screw (Carburetor Nozzle)
788	691039	Bracket-Fuel Pump	1169	693140	Screw (Carburetor Cover Plate)
789	695050	Harness-Wiring			RPM Settings:Low Speed: 1900-2100 High Speed: 3000-3200
789A	696576	Harness-Wiring			• Included in Engine Gasket Set, Key. No. 358
797	691029	Nut (Brush Retainer)			Ø Included in Carburetor Overhaul Kit, Key. No. 121
797A	693167	Nut (Brush Retainer)			‡ Included in Carburetor Gasket Set, Key. No. 977
798	690967	Screw (Rocker Arm)			+ Included in Valve Gasket Set, Key. No. 1095
801	691283	Cap-Drive			
802	691286	Cap-End			
803	-----	Housing-Starter (Service with 691262 Starter Motor)			

NOTE: All component dimensions given in U.S. inches 1 inch = 25.4 mm

SUGGESTED GUIDE FOR SIGHTING SLOPES FOR SAFE OPERATION

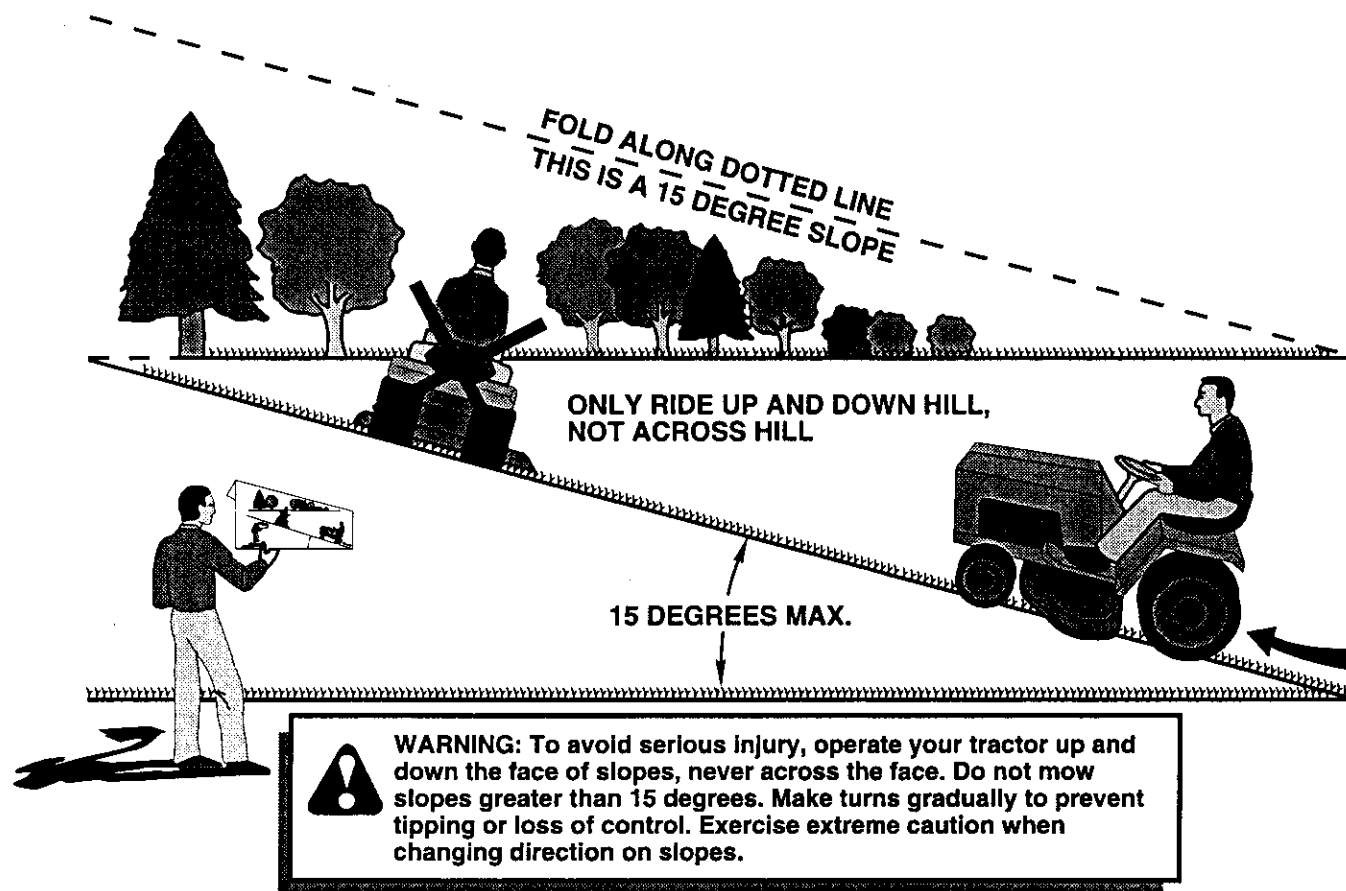

WARNING: To avoid serious injury, operate your tractor up and down the face of slopes, never across the face. Do not mow slopes greater than 15 degrees. Make turns gradually to prevent tipping or loss of control. Exercise extreme caution when changing direction on slopes.

1. Fold this page along dotted line indicated above.
2. Hold page before you so that its left edge is vertically parallel to a tree trunk or other upright structure.
3. Sight across the fold in the direction of hill slope you want to measure.
4. Compare the angle of the fold with the slope of the hill.

Get it fixed, at your home or ours!

Your Home

For repair – **in your home** – of **all** major brand appliances, lawn and garden equipment, or heating and cooling systems, **no matter who made it, no matter who sold it!**

For the replacement parts, accessories and owner's manuals that you need to do-it-yourself.

For Sears professional installation of home appliances and items like garage door openers and water heaters.

1-800-4-MY-HOME[®] Anytime, day or night
(1-800-469-4663) (U.S.A. and Canada)
www.sears.com www.sears.ca

Our Home

For repair of carry-in products like vacuums, lawn equipment, and electronics, call or go on-line for the nearest **Sears Parts and Repair Center.**

1-800-488-1222 Anytime, day or night (U.S.A. only)
www.sears.com

To purchase a protection agreement on a product serviced by Sears:

1-800-827-6655 (U.S.A.) **1-800-361-6665** (Canada)

Para pedir servicio de reparación a domicilio, y para ordenar piezas:

1-888-SU-HOGARSM
(1-888-784-6427)

Au Canada pour service en français:

1-800-LE-FOYER^{MC}
(1-800-533-6937)
www.sears.ca

SEARS

© Sears, Roebuck and Co.

® Registered Trademark / TM Trademark / SM Service Mark of Sears, Roebuck and Co.

® Marca Registrada / TM Marca de Fábrica / SM Marca de Servicio de Sears, Roebuck and Co.

^{MC} Marque de commerce / ^{MD} Marque déposée de Sears, Roebuck and Co.