

Owner's Manual



ORBITAL ACTION SABRE SAW

Double Insulated

Model No.
315.172281

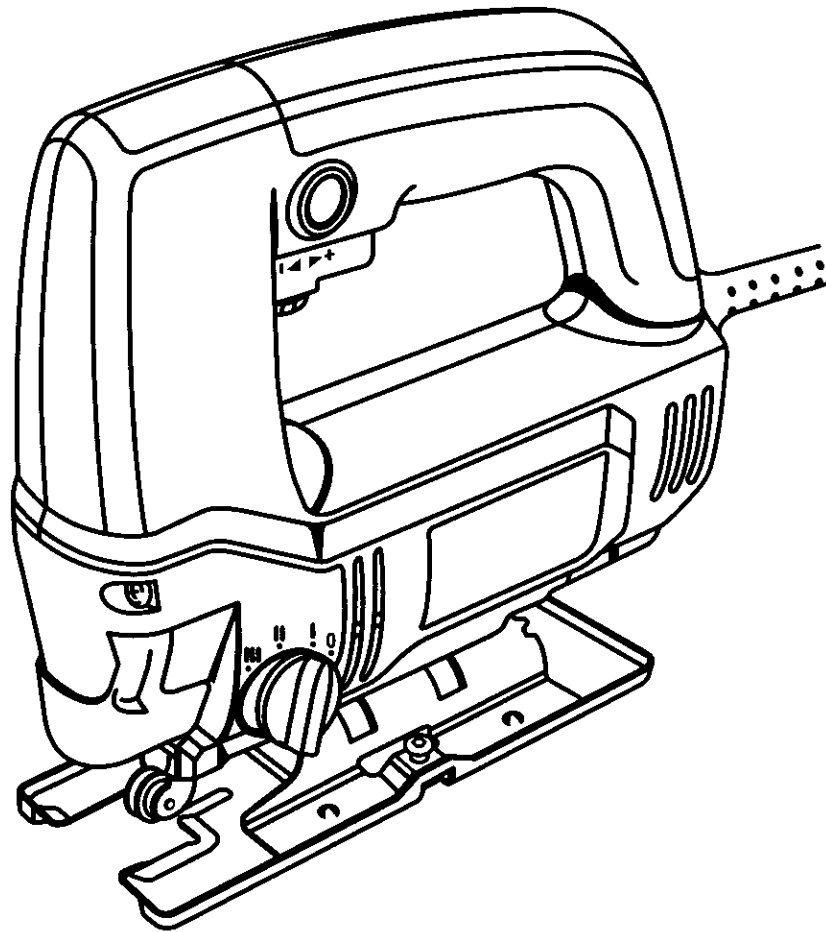

Save this manual for
future reference

⚠ CAUTION: Read and follow
all Safety Rules and Operating
Instructions before first use of
this product.

- Safety
- Features
- Operation
- Maintenance
- Parts List

Customer Help Line 1-800-932-3188

Sears, Roebuck and Co., Hoffman Estates, IL 60179 USA
Visit the Craftsman web page: www.sears.com/craftsman

972000-902
7-01



TABLE OF CONTENTS

■ Table Of Contents	2
■ Warranty	2
■ Introduction	2
■ Rules For Safe Operation	3-5
■ Product Specifications	6
■ Unpacking	6
■ Accessories	6
■ Features	7
■ Operation	8-13
■ Maintenance	15
■ Exploded View and Repair Parts List	16-17
■ Parts Ordering / Service	18

WARRANTY

FULL ONE YEAR WARRANTY ON CRAFTSMAN ORBITAL ACTION SABRE SAW

If this **CRAFTSMAN** Orbital Action Sabre Saw fails to give complete satisfaction within one year from the date of purchase, **RETURN IT TO THE NEAREST SEARS STORE IN THE UNITED STATES**, and Sears will repair it, free of charge.

If this **CRAFTSMAN** Orbital Action Sabre Saw is used for commercial or rental purposes, this warranty applies for only 90 days from the date of purchase.

This warranty gives you specific legal rights, and you may also have other rights which vary from state to state.

Sears, Roebuck and Co., Dept. 817WA, Hoffman Estates, IL 60179

INTRODUCTION

Your saw has many features for making cutting operations more pleasant and enjoyable. Safety, performance and dependability have been given top priority in the design of this saw making it easy to maintain and operate.

 **CAUTION:** Carefully read through this entire owner's manual before using your new saw. Pay close attention to the Rules For Safe Operation, Warnings and Cautions. If you use your saw properly and only for what it is intended, you will enjoy years of safe, reliable service.

RULES FOR SAFE OPERATION

The purpose of safety symbols is to attract your attention to possible dangers. The safety symbols, and the explanations with them, deserve your careful attention and understanding. The safety warnings do not by themselves eliminate any danger. The instructions or warnings they give are not substitutes for proper accident prevention measures.

SYMBOL MEANING



SAFETY ALERT SYMBOL: Indicates caution or warning. May be used in conjunction with other symbols or pictographs.



DANGER: Failure to obey a safety warning will result in serious injury to yourself or to others. Always follow the safety precautions to reduce the risk of fire, electric shock and personal injury.



WARNING: Failure to obey a safety warning can result in serious injury to yourself or to others. Always follow the safety precautions to reduce the risk of fire, electric shock and personal injury.



CAUTION: Failure to obey a safety warning may result in property damage or personal injury to yourself or to others. Always follow the safety precautions to reduce the risk of fire, electric shock and personal injury.

NOTE: Advises you of information or instructions vital to the operation or maintenance of the equipment.

DOUBLE INSULATION

Double insulation is a concept in safety, in electric power tools which eliminates the need for the usual three-wire grounded power cord. All exposed metal parts are isolated from internal metal motor components with protecting insulation. Double insulated tools do not need to be grounded.

 **WARNING:** Do not attempt to operate this tool until you have read thoroughly and understand completely all instructions, safety rules, etc. contained in this manual. Failure to comply can result in accidents involving fire, electric shock, or serious personal injury. Save owner's manual and review frequently for continuing safe operation, and instructing others who may use this tool.

READ ALL INSTRUCTIONS

- **KNOW YOUR POWER TOOL.** Read owner's manual carefully. Learn its applications and limitations as well as the specific potential hazards related to this tool.
- **GUARD AGAINST ELECTRICAL SHOCK** by preventing body contact with grounded surfaces. For example; pipes, radiators, ranges, refrigerator enclosures.
- **KEEP GUARDS IN PLACE AND IN WORKING ORDER.**

IMPORTANT

Servicing of a tool with double insulation requires extreme care and knowledge of the system and should be performed only by a qualified service technician. For service we suggest you return the tool to your nearest Sears Store for repair. Always use original factory replacement parts when servicing.

- **KEEP WORK AREA CLEAN.** Cluttered areas and benches invite accidents.
- **AVOID DANGEROUS ENVIRONMENT.** Don't use power tools in damp or wet locations or expose to rain. Keep work area well lit.
- **KEEP CHILDREN AND VISITORS AWAY.** All visitors should wear safety glasses and be kept a safe distance from work area. Do not let visitors contact tool or extension cord.
- **STORE IDLE TOOLS.** When not in use, tools should be stored in a dry and high or locked-up place – out of the reach of children.
- **DON'T FORCE TOOL.** It will do the job better and safer at the rate for which it was designed.
- **USE RIGHT TOOL.** Don't force small tool or attachment to do the job of a heavy duty tool. Don't use tool for purpose not intended – for example – A circular saw should never be used for cutting tree limbs or logs.

RULES FOR SAFE OPERATION (Continued)

- **WEAR PROPER APPAREL.** Do not wear loose clothing or jewelry that can get caught in tool's moving parts and cause personal injury. Rubber gloves and nonskid footwear are recommended when working outdoors. Wear protective hair covering to contain long hair and keep it from being drawn into nearby air vents.
- **ALWAYS WEAR SAFETY GLASSES.** Everyday eyeglasses have only impact-resistant lenses; they are **not** safety glasses.
- **PROTECT YOUR LUNGS.** Wear a face or dust mask if the cutting operation is dusty.
- **PROTECT YOUR HEARING.** Wear hearing protection during extended periods of operation.
- **DON'T ABUSE CORD.** Never carry tool by cord or yank it to disconnect from receptacle. Keep cord from heat, oil, and sharp edges.
- **SECURE WORK.** Use clamps or a vise to hold work. It's safer than using your hand and it frees both hands to operate tool.
- **DON'T OVERREACH.** Keep proper footing and balance at all times. Do not use on a ladder or unstable support. Secure tools when working at elevated positions.
- **MAINTAIN TOOLS WITH CARE.** Keep tools sharp and clean for best and safest performance. Follow instructions for lubricating and changing accessories.
- **DISCONNECT TOOLS.** When not in use, before servicing, or when changing attachments, blades, bits, cutters, etc., all tools should be disconnected from power supply.
- **REMOVE ADJUSTING KEYS AND WRENCHES.** Form habit of checking to see that keys and adjusting wrenches are removed from tool before turning it on.
- **AVOID ACCIDENTAL STARTING.** Don't carry plugged-in tool with finger on switch. Be sure switch is off when plugging in.
- **MAKE SURE YOUR EXTENSION CORD IS IN GOOD CONDITION.** When using an extension cord, be sure to use one heavy enough to carry the current your product will draw. An undersized cord will cause a drop in line voltage resulting in loss of power and overheating. A wire gage size (A.W.G.) of at least 16 is recommended for an extension cord 100 feet or less in length. A cord exceeding 100 feet is not recommended. If in doubt, use the next heavier gage. The smaller the gage number, the heavier the cord.
- **OUTDOOR USE EXTENSION CORDS.** When tool is used outdoors, use only extension cords suitable for use outdoors. Outdoor approved cords are marked with the suffix W-A, for example - SJTW-A or SJOW-A.
- **KEEP BLADES CLEAN AND SHARP.** Sharp blades minimize stalling and kickback.
- **KEEP HANDS AWAY FROM CUTTING AREA.** Keep hands away from blades. Do not reach underneath work while blade is moving. Do not attempt to remove cut material when blade is moving.
- **NEVER USE IN AN EXPLOSIVE ATMOSPHERE.** Normal sparking of the motor could ignite fumes.
- **INSPECT TOOL CORDS PERIODICALLY** and if damaged, have repaired by authorized service facility. Stay constantly aware of cord location and keep it well away from the blade.
- **INSPECT EXTENSION CORDS PERIODICALLY** and replace if damaged.
- **KEEP HANDLES DRY, CLEAN, AND FREE FROM OIL AND GREASE.** Always use a clean cloth when cleaning. Never use brake fluids, gasoline, petroleum-based products, or any strong solvents to clean your tool.
- **STAY ALERT AND EXERCISE CONTROL.** Watch what you are doing and use common sense. Do not operate tool when you are tired. Do not rush.
- **CHECK DAMAGED PARTS.** Before further use of the tool, a guard or other part that is damaged should be carefully checked to determine that it will operate properly and perform its intended function. Check for alignment of moving parts, binding of moving parts, breakage of parts, mounting and any other conditions that may affect its operation. A guard or other part that is damaged should be properly repaired or replaced by an authorized service center.
- **DO NOT USE TOOL IF SWITCH DOES NOT TURN IT ON AND OFF.** Have defective switches replaced by an authorized service center.
- **CUTTING INTO ELECTRICAL WIRING IN WALLS CAN CAUSE BLADE, BLADE CLAMP, AND SAW BAR ASSEMBLY TO BECOME ELECTRICALLY LIVE.** Do not touch metal parts when cutting into a wall; grasp only the insulated handle(s) provided on the tool. Make sure hidden electrical wiring, water pipes, and mechanical hazards are not in the blade path when cutting into a wall.

RULES FOR SAFE OPERATION (Continued)

- **AVOID CUTTING NAILS.** Inspect for and remove all nails from lumber before cutting.

⚠ WARNING: TO AVOID POSSIBLE SERIOUS INJURY, KEEP HANDS AND FINGERS FROM BETWEEN THE GEAR HOUSING AND SAW BLADE CLAMP.

- **NEVER** touch the blade or other moving parts during use.
- **NEVER** start a tool when its moving component is in contact with the workpiece.
- **NEVER** lay a tool down before its moving parts have come to a complete stop.
- **DO NOT** operate this tool while under the influence of drugs, alcohol, or any medication.
- **POLARIZED PLUGS.** To reduce the risk of electric shock, this tool has a polarized plug (one blade is wider than the other). This plug will fit in a polarized outlet only one way. If the plug does not fit fully in the outlet, reverse the plug. If it still does not fit, contact a qualified electrician to install the proper outlet. Do not change the plug in any way.

- **WHEN SERVICING USE ONLY IDENTICAL CRAFTSMAN REPLACEMENT PARTS.**

- **SAVE THESE INSTRUCTIONS.** Refer to them frequently and use them to instruct others who may use this tool. If you loan someone this tool, loan them these instructions also.

⚠ WARNING: Some dust created by power sanding, sawing, grinding, drilling, and other construction activities contains chemicals known to cause cancer, birth defects or other reproductive harm. Some examples of these chemicals are:

- lead from lead-based paints,
- crystalline silica from bricks and cement and other masonry products, and
- arsenic and chromium from chemically-treated lumber.

Your risk from these exposures varies, depending on how often you do this type of work. To reduce your exposure to these chemicals: work in a well ventilated area, and work with approved safety equipment, such as those dust masks that are specially designed to filter out microscopic particles.

⚠ Look for this symbol to point out important safety precautions. It means attention!!! Your safety is involved.

⚠ WARNING:



The operation of any saw can result in foreign objects being thrown into your eyes, which can result in severe eye damage. Before beginning power tool operation, always wear safety goggles or safety glasses with side shields and a full face shield when needed. We recommend Wide Vision Safety Mask for use over eyeglasses or standard safety glasses with side shields, available at Sears Retail Stores. Always wear eye protection which is marked to comply with ANSI Z87.1.

SAVE THESE INSTRUCTIONS

PRODUCT SPECIFICATIONS

Length of Stroke	3/4 in.	Switch	Variable Speed
Strokes Per Minute	0 - 3000 spm	Orbital Motion	
Rating	120 Volts, 60 Hz, AC	Blade / Hex Key Storage	
Input	4.0 Amperes	Net Weight	3.4 lbs.

UNPACKING

Your saw has been shipped completely assembled except for the blade. Inspect it carefully to make sure no breakage or damage has occurred during shipping. If any parts are damaged or missing, contact your nearest Sears Retail Store to obtain replacement parts before attempting to operate saw. A blade, vacuum attachment, and this owner's manual are also included.

 **WARNING:** If any parts are missing, do not operate this tool until the missing parts are replaced. Failure to do so could result in possible serious personal injury.

ACCESSORIES

The following recommended accessories are currently available at Sears Retail Stores.

- Bi-Metal Blades
- Blade Assortment Sets
- Fine Scrolling Blades
- General Purpose Blades
- Metal Cutting Blades
- Wood Cutting Blades

 **WARNING:** The use of attachments or accessories not listed might be hazardous.

FEATURES

KNOW YOUR SAW

See Figure 1.

Before attempting to use your saw, familiarize yourself with all operating features and safety requirements.

ELECTRICAL CONNECTION

Your saw has a precision built electric motor. It should be connected to a **power supply that is 120 volts, 60 Hz, AC only (normal household current)**. Do not operate this tool on direct current (DC). A substantial voltage drop will cause a loss of power and overheating. If your tool does not operate when plugged into an outlet, double-check the power supply.

CHIP SHIELD

A clear plastic chip shield is installed on the front of your saw for protection against flying dust and chips. The flip-up design of the chip shield makes installing and removing blades easier. **For your protection, do not use saw without chip shield properly in place.**

APPLICATIONS

(Use only for the purpose listed below)

- Cutting wood surfaces.
- Cutting thin sheet metal.
- Cutting plastics and laminates.

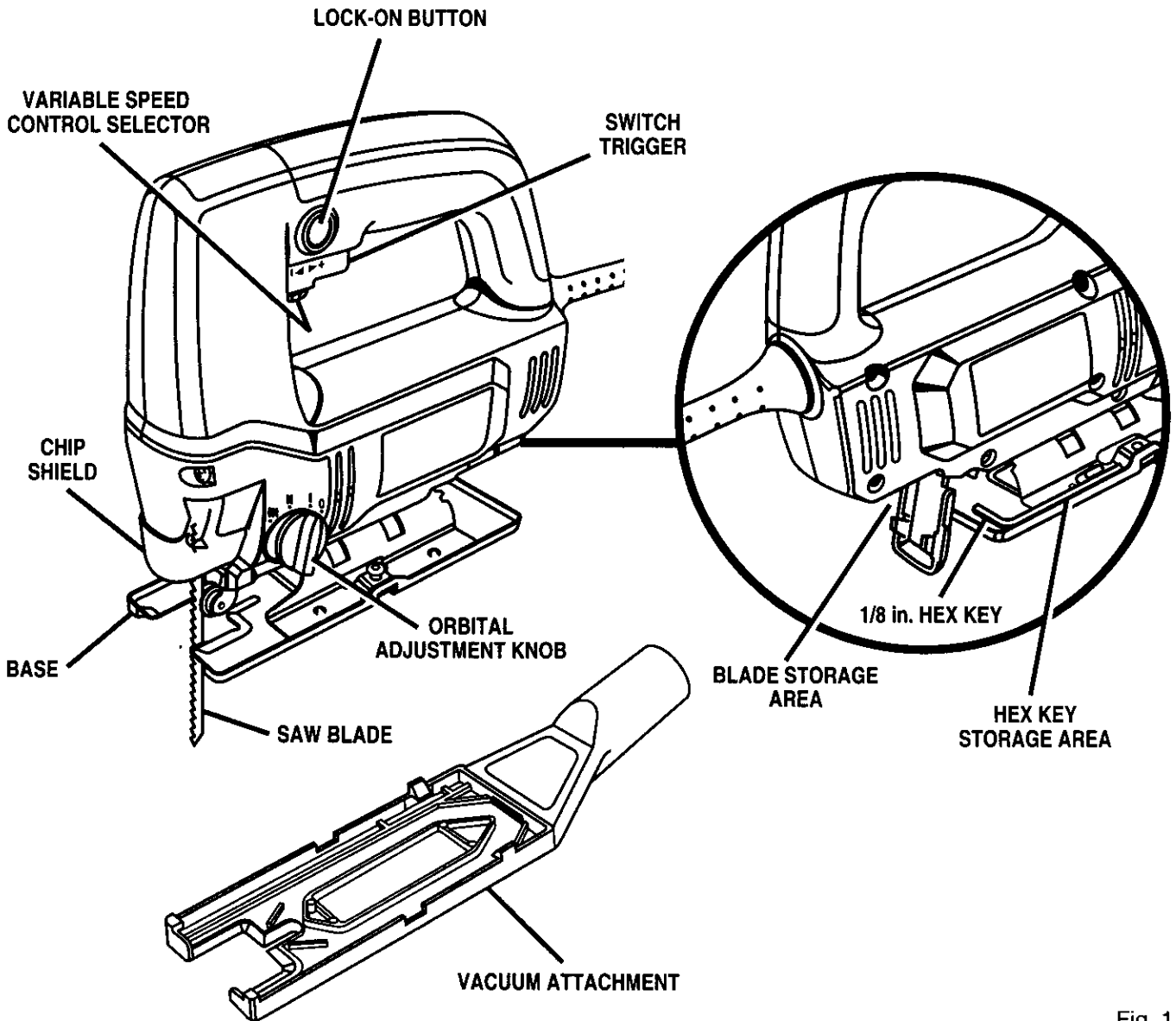

Fig. 1

⚠ WARNING: Do not allow familiarity with tools to make you careless. Remember that a careless fraction of a second is sufficient to inflict severe injury.

OPERATION

SWITCH

See Figure 2.

To turn your saw **ON**, depress the switch trigger. Release switch trigger to turn your saw **OFF**.

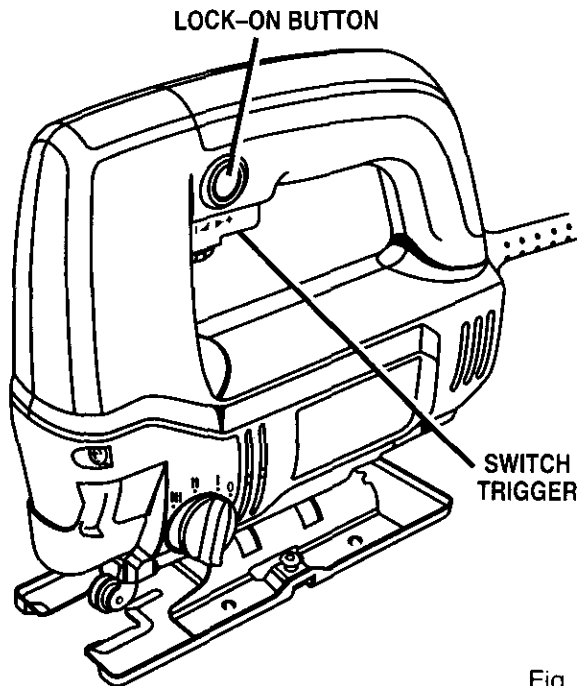

Fig. 2

LOCK-ON BUTTON

See Figure 2.

Your saw is equipped with a **lock-on** feature, which is convenient when continuous cutting for extended periods of time is required. **To lock-on**, depress the switch trigger, push in and hold the lock-on button located on the side of the handle, then release switch trigger. Release lock-on button and your saw will continue running.

To release the lock, depress the switch trigger and release.

If you have the lock-on feature engaged during use and your saw becomes disconnected from power supply, disengage the lock-on feature immediately.

⚠ WARNING: Before connecting your saw to power supply source, always check to be sure it is not in lock-on position (depress and release switch trigger). Failure to do so could result in accidental starting of your saw resulting in possible serious injury. Also, do not lock the trigger on jobs where your saw may need to be stopped suddenly.

VARIABLE SPEED

See Figure 3.

Your saw has a variable speed control selector designed to allow operator control and adjustment of

speed and power limits. The speed and power of your saw can be increased or decreased by rotating the variable speed control selector in the direction of the arrows shown in Figure 3.

Note: Hold your saw in normal operating position and turn the variable speed control selector counterclockwise to increase speed and power. Turn clockwise to decrease speed and power.

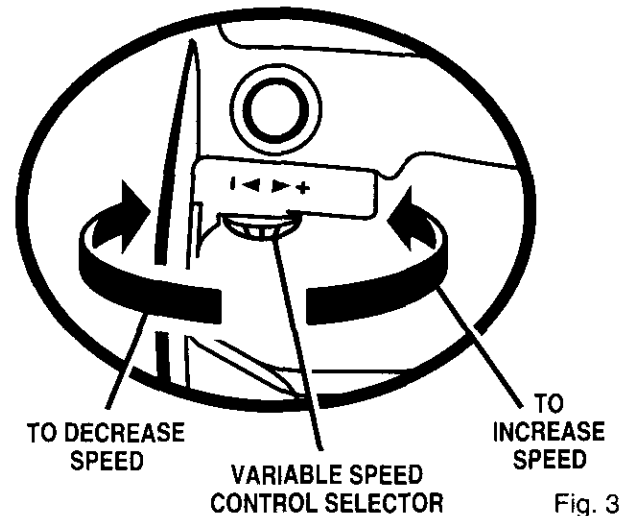

Fig. 3

If you desire to lock the switch on at a given speed, depress the switch trigger, push in and hold the lock-on button, and release the switch trigger. Next, adjust the variable speed control selector until the desired speed is reached.

Note: If the variable speed control selector is fully turned in the clockwise direction (zero setting) your saw may not run.

Note: If you desire not to use the variable speed control selector, turn it in the full counterclockwise direction. This will allow the speed of your saw to be controlled by the amount of switch trigger depression.

Avoid running your saw at low speeds for extended periods of time. Running at low speeds under constant usage may cause your saw to become overheated. If this occurs, cool your saw by running it without a load and at full speed.

The following guidelines may be used in determining correct speed for various applications:

LOW speed is ideal when minimum speed and power is required, for example, starting cuts.

MEDIUM speed is suitable for cutting hard metals, plastics, and laminates.

HIGH speed produces best results when maximum power is required, for example, cutting wood. Soft metals such as aluminum, brass, and copper also require high speeds.

OPERATION

BLADE AND HEX KEY STORAGE

See Figure 4.

Convenient features on your saw are blade and hex key storage areas. As shown in Figure 4, the blade storage area is located on the back of your saw and the hex key storage area is located on the base. They are convenient for storing extra blades, storing blades when not in use, and storing the hex key provided with your saw.

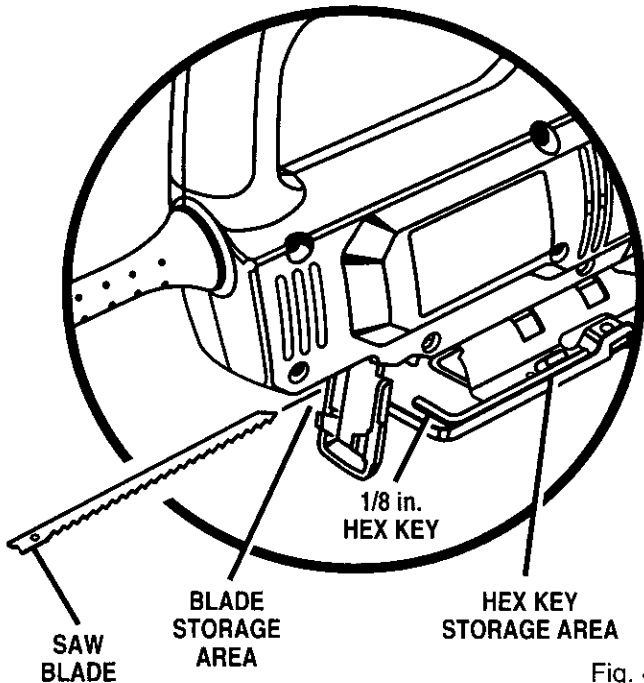

Fig. 4

BLADE STORAGE

To open: Push the door down with your thumb or finger.

Place blades in blade storage area.

To close: Push the door up with your thumb or finger.

HEX KEY STORAGE

Insert hex key into storage area when not in use. It is located on the base of your saw as shown in Figure 4.

⚠ WARNING: Do not insert saw blade or hex key into air vents. They could come in contact with electrically live internal parts, and cause electrical shock resulting in serious injury.

⚠ WARNING: Your saw should never be connected to power supply when you are assembling parts, making adjustments, installing or removing blades, or when not in use. Disconnecting your saw will prevent accidental starting that could cause serious injury.

TO INSTALL BLADES

See Figure 5.

■ Unplug your saw.

⚠ WARNING: Failure to unplug your saw could result in accidental starting causing possible serious injury.

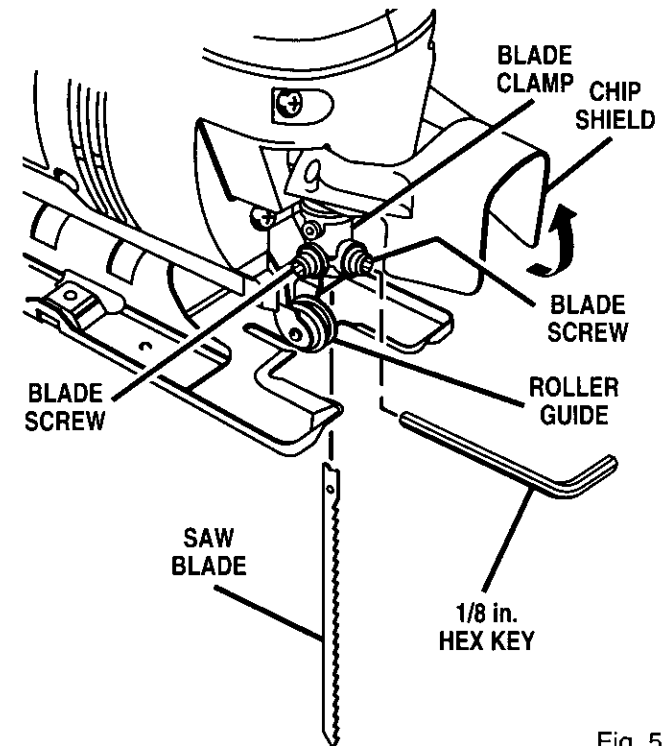

Fig. 5

- Raise chip shield.
- Using the 1/8 in. hex key provided, loosen the blade screws in the blade clamp.
- Insert saw blade as far as possible into slot in saw bar.
- Check to make sure the back of the saw blade is properly positioned in the groove of the roller guide.
- Tighten blade screws securely against blade.

Note: The holes in the saw blades were not designed for alignment with the screw hole on the blade clamp.

- Lower chip shield.

⚠ WARNING: To avoid possible serious injury, always wear safety goggles or safety glasses with side shields. Keep hands and fingers from between the motor housing and blade clamp, and do not reach underneath work while blade is cutting.

OPERATION

⚠ WARNING: To avoid serious personal injury, do not use saw without chip shield properly in place.

GENERAL CUTTING

See Figure 6.

Rest the front of the saw base on the workpiece and align cutting edge of the blade with the line on your workpiece. Make sure the power cord is out of your way and not in the line of cut. Start your saw and move it forward on the work surface. Apply downward pressure to keep the saw steady and only enough forward pressure to keep the blade cutting.

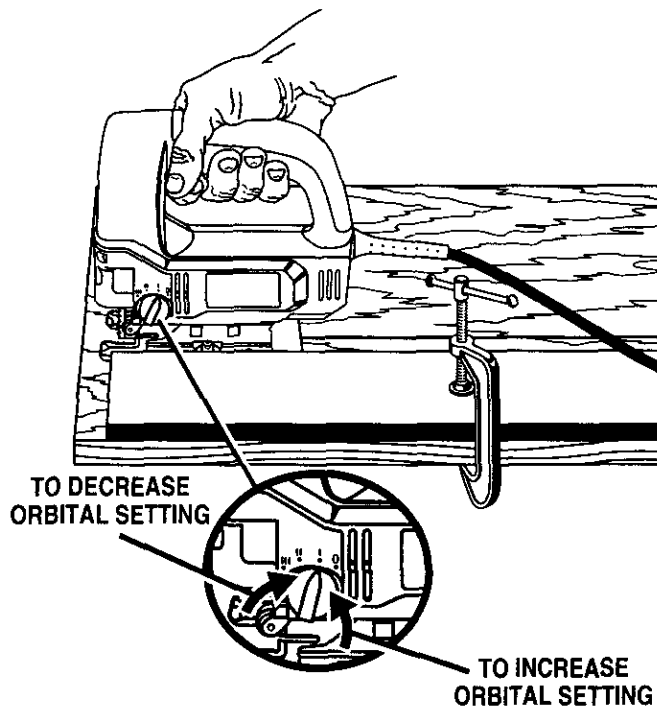

Fig. 6

DO NOT FORCE YOUR SAW

Forcing your saw may overheat the motor and break saw blades. Broken blades can be reused by loosening the blade screws until the portion left in the blade clamp drops out, then putting the remainder of the blade back into the blade clamp and retightening the blade screws. It may be necessary to flatten the tooth set in the area to be inserted into the blade clamp when using broken blades.

ORBITAL MOTION

See Figure 6.

The blade of your saw cuts in orbital motion. This feature is adjustable and provides faster more efficient cutting. With orbital motion the blade cuts through your work in the upstroke but does not drag across your work in the downstroke. The higher settings should be used when fast cutting in soft material is desired. The lower settings should be used when cutting materials with more resistance.

STRAIGHT CUT

See Figure 6.

A straight cut can be made by clamping a piece of wood or straightedge to the workpiece and guiding the edge of your saw against it. Make the cut from one direction only: don't cut halfway and complete the cut from the opposite end.

SCROLL CUTTING

See Figure 7.

Scroll cuts can be made with your saw by guiding the direction of the cut with applied pressure on the handle as shown in Figure 7.

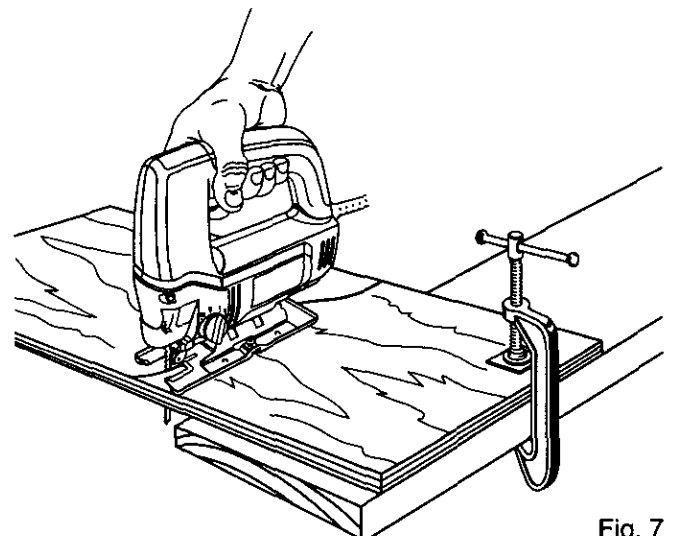

Fig. 7

⚠ WARNING: Excessive side pressure to the blade could result in broken blades or damage to the material being cut.

OPERATION

ANGLE CUTTING (Bevel Cutting)

See Figures 8 and 9.

Bevel cutting angles may be adjusted from 0° to 45° right or left. Angles for cuts from 0° to 45° in 15° increments are marked on a scale on both the left and right side of the base. Notches on the rear of the base provide positive stops at each of the above mentioned 15° increments. A protractor is recommended when accurate cuts are required.

- Using the 1/8 in. hex key provided, loosen the base pivot screws until the base can be moved.
- Slide base forward slightly until base pivot screws can move freely in slots in base. See Figure 8.

Note: Clamp plate should always be in full rear position, as shown in Figure 8, unless vacuum attachment is in use.

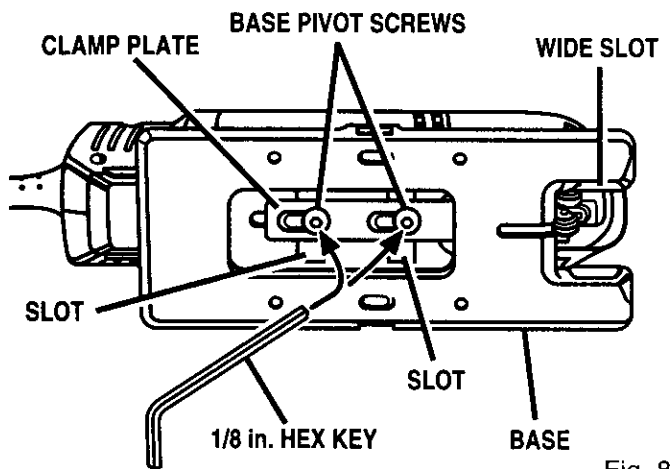

Fig. 8

- Align the mark, on the base, of the desired angle with the edge of the motor housing.
- Once the desired angle is reached, slide base back until tab on motor housing aligns with the appropriate notch on rear of base. See Figure 9.

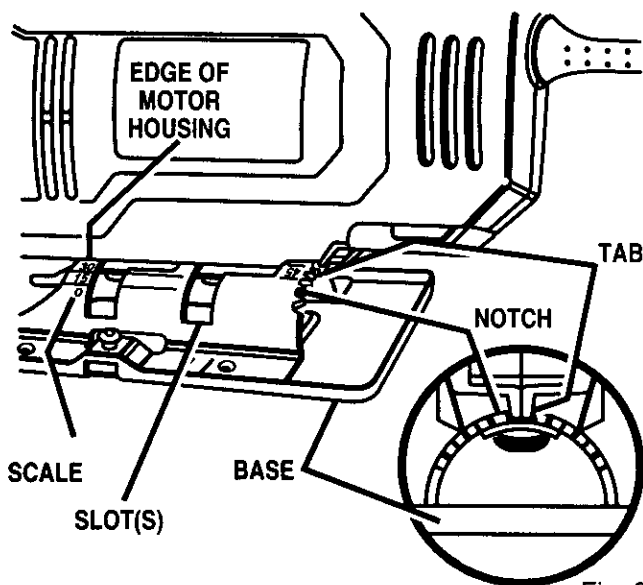

Fig. 9

Note: When making a set-up for accurate cuts with a protractor, or for angles other than the preset 15° increments, the positive stop notches on the rear of the base are not used.

- Tighten the base pivot screws securely.
- Return hex key to storage area.

Note: The wide slot in the base must be used when making bevel cuts, scroll cuts, plunge cuts, and when cutting metal.

PLUNGE CUTTING

See Figure 10.

⚠ WARNING: To avoid loss of control, broken blades, or damage to the material being cut, always use extreme caution when making plunge cuts. We do not recommend plunge cutting on materials other than wood.

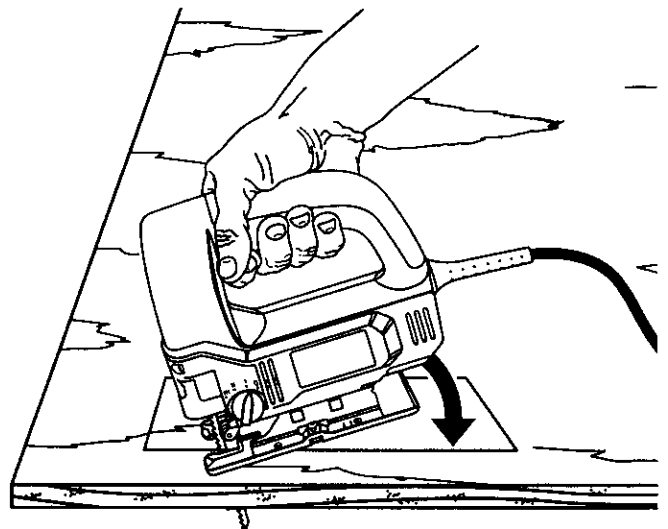

Fig. 10

TO MAKE A PLUNGE CUT

- Mark the line of cut clearly on the workpiece.
- Set the cutting angle at 0°.
- Tilt your saw forward so that it rests on the front edge of the base and blade will not come in contact with the workpiece when the saw is turned on.
- Make sure the blade is inside the area to be cut.
- Using high speed, start your saw and slowly lower the blade into the workpiece until the blade cuts through the wood. See Figure 10.
- Continue lowering the blade into the workpiece until the base rests flat on the work surface, then move the saw forward to complete the opening.
- Use only the 7 teeth per inch blade for this type of cut.

OPERATION

SPLINTER-FREE CUTTING

See Figure 11.

The base of your saw has a narrow slot to permit splinter-free cutting. It is especially useful when cutting plywood. This feature should only be used when making straight cuts or circle cuts. It is not for bevel cutting or plunge cutting.

Note: The non-orbital setting also helps reduce splintering when cutting plywood.

HOW TO POSITION BASE IN THE SPLINTER-FREE CUTTING POSITION:

- Unplug your saw.

⚠ WARNING: Failure to unplug your saw could result in accidental starting causing possible serious injury.

- Using the 1/8 in. hex key provided, loosen base pivot screws and slide base forward. See Figure 11.
- Always set the cutting angle at 0° for splinter-free cutting. To set cutting angle at 0°, align the 0° mark on the scale with the edge of the motor housing.

Note: When setting angle at 0° for splinter-free cutting, the positive stop notches on the rear of the base are not used.

Note: Clamp plate should always be in full rear position, as shown in Figure 11, unless vacuum attachment is in use.

- Tighten base pivot screws securely.
- Remove hex key and return it to storage area.

METAL CUTTING

Many kinds of metals can be cut with your saw. Be careful not to twist or bend the blades. **Do not force.** If the blade chatters or vibrates excessively, use a finer-tooth blade or higher speed. If blade heats excessively, use lower speed. If blade teeth become filled or clogged when cutting soft metals, such as aluminum, use a coarser-tooth blade or lower speed. We recommend use of oil when cutting metals to keep blades cool, increase cutting action, and prolong blade life. Clamp the work firmly and saw close to the clamping point to eliminate any vibration of the work being cut.

When cutting conduit, pipe or angle iron, clamp work in a vise if possible and saw close to the vise. To cut thin sheet materials, "sandwich" the material between hardboard or plywood and clamp the layers to eliminate vibration and material tearing. By doing this, the material will be cut smoothly. Lay out your pattern or line of cut on top of the "sandwich".

Important – When cutting metal, keep exposed portion of saw bar clean and free of metal chips by wiping frequently with an oily cloth. Use extreme caution in disposing of oily cloth after completion of job to prevent potential fire hazard.

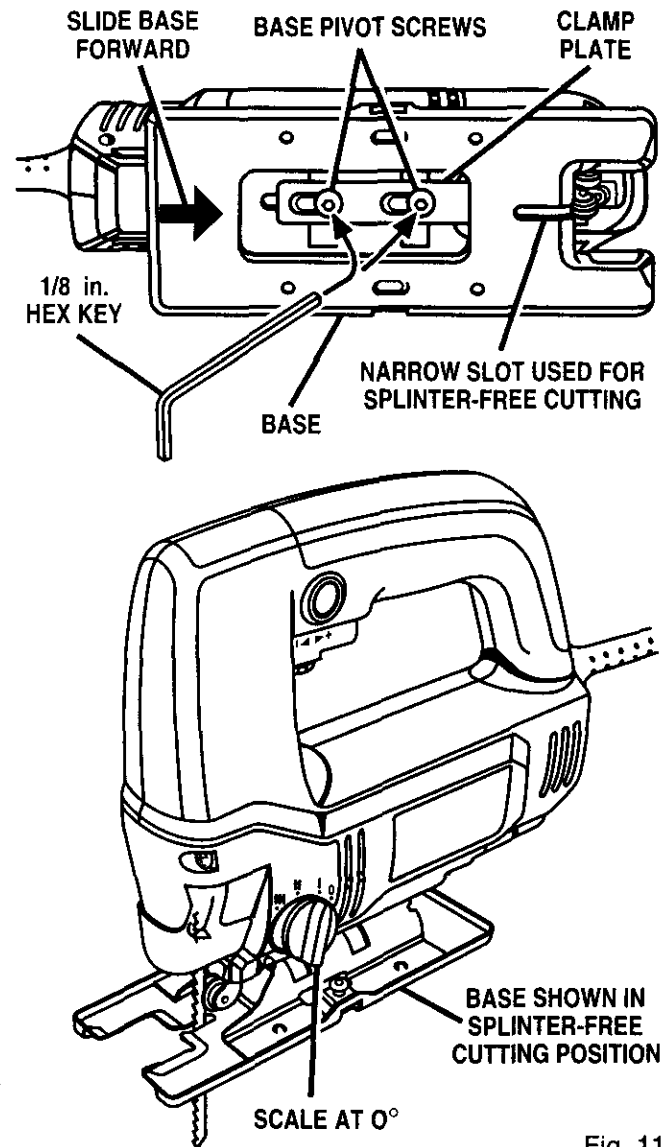

Fig. 11

OPERATION

DUSTLESS FEATURE

See Figures 12 and 13.

For dustless operation, a vacuum attachment has been provided with your saw. It attaches to the saw base.

TO INSTALL:

- Unplug your saw.

⚠ WARNING: Failure to unplug your saw could result in accidental starting causing possible serious injury.

- Remove blade from saw.
- Using the 1/8 in. hex key provided, loosen the base pivot screws and slide clamp plate forward. See Figure 12.

Note: This position is for vacuum attachment use only. Sliding the clamp plate forward, covers the dust blower chute and allows sawdust and chips to be pulled back through the vacuum attachment.

- Using the 1/8 in. hex key provided, tighten the base pivot screws.
- Remove hex key and return it to storage area.

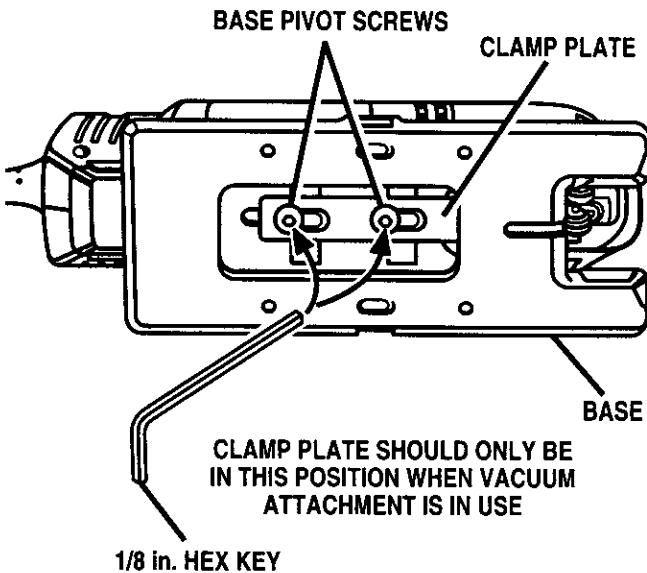

Fig. 12

- Place front of saw base under the tabs located on front of vacuum attachment and press to snap on. See Figure 13.

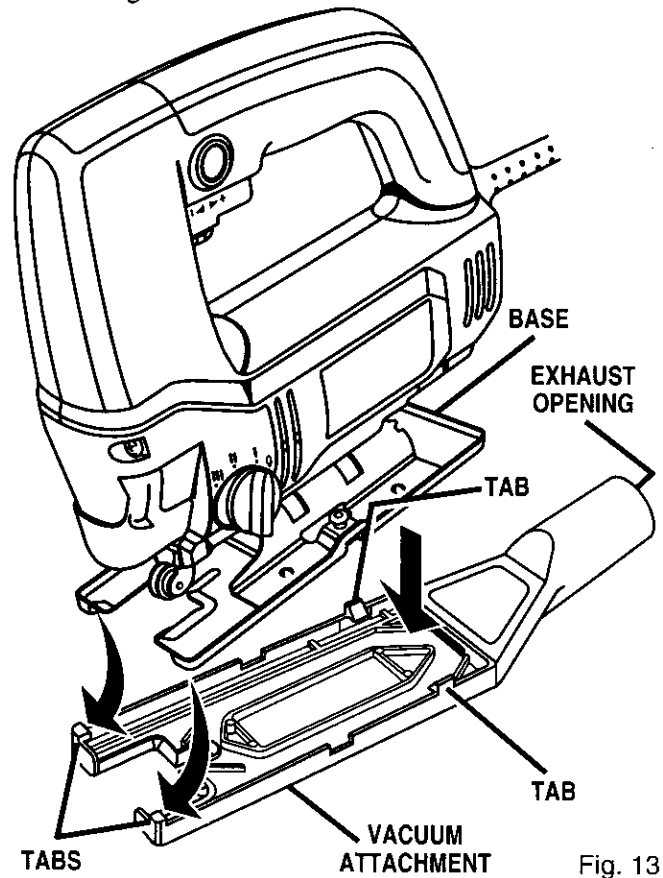

Fig. 13

- Replace blade.
- Connect exhaust opening to dust collection system.

TO REMOVE:

- Unplug your saw.

⚠ WARNING: Failure to unplug your saw could result in accidental starting causing possible serious injury.

- Remove blade from saw.
- Spread tabs located on the rear of the attachment then remove attachment from base.
- Using the 1/8 in. hex key provided, loosen the base pivot screws and slide clamp plate to the rear.

Note: After removing vacuum attachment, clamp plate must be slid back to the rear for normal operating position. This allows the air to flow out around the blade blowing sawdust and chips away from the operators view of the line of cut.

OPERATION

OPTIONAL EDGE GUIDE

See Figure 14.

An optional edge guide, part number 975225-001, is available for use with your saw. It can be used for making crosscuts and rip cuts.

TO INSTALL:

- Unplug your saw.
- ⚠ **WARNING:** Failure to unplug your saw could result in accidental starting causing possible serious injury.
- Insert arm through the two slots in the base of your saw as shown in Figure 14.
- Adjust edge guide to the desired width and lock in place with the edge guide screw.

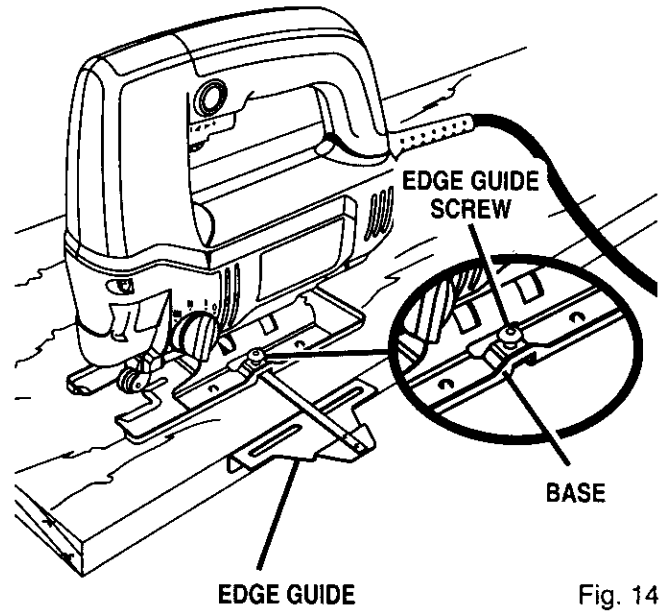

Fig. 14

NOTES

MAINTENANCE

⚠ WARNING: When servicing, use only identical Craftsman replacement parts. Use of any other part may create a hazard or cause product damage.

GENERAL

Only the parts shown on parts list, page 17, are intended to be repaired or replaced by the customer. All other parts represent an important part of the double insulation system and should be serviced only by a qualified Sears service technician.

Avoid using solvents when cleaning plastic parts. Most plastics are susceptible to damage from various types of commercial solvents and may be damaged by their use. Use clean cloths to remove dirt, carbon dust, etc.

⚠ WARNING: Do not at any time let brake fluids, gasoline, petroleum-based products, penetrating oils, etc. come in contact with plastic parts. They contain chemicals that can damage, weaken or destroy plastic.

It has been found that electric tools are subject to accelerated wear and possible premature failure when they are used on fiberglass boats, sports cars, wallboard, spackling compounds, or plaster. The chips and grindings from these materials are highly abrasive to electric tool parts such as bearings, brushes, commutators, etc. Consequently, it is not recommended that this tool be used for extended work on any fiberglass material, wallboard, spackling compounds, or plaster. During any use on these materials it is extremely important that the tool is cleaned frequently by blowing with an air jet.

LUBRICATION

All of the bearings in this tool are lubricated with a sufficient amount of high grade lubricant for the life of the unit under normal operating conditions. Therefore, no further lubrication is required.

EXTENSION CORDS

The use of any extension cord will cause some loss of power. To keep the loss to a minimum and to prevent tool overheating, use an extension cord that is heavy enough to carry the current the tool will draw.

A wire gage size (A.W.G.) of at least **16** is recommended for an extension cord 100 feet or less in length. When working outdoors, use an extension cord that is suitable for outdoor use. The cord's jacket will be marked **WA**.

⚠ CAUTION: Keep extension cords away from the cutting area and position the cord so that it will not get caught on lumber, tools, etc., during cutting operation.

⚠ WARNING: Check extension cords before each use. If damaged replace immediately. Never use tool with a damaged cord since touching the damaged area could cause electrical shock resulting in serious injury.

Extension cords suitable for use with your saw are available at your nearest Sears Retail Store.

⚠ WARNING: Always wear safety goggles or safety glasses with side shields during power tool operation or when blowing dust. If operation is dusty, also wear a dust mask.

SEE NOTE "A" PAGE 17

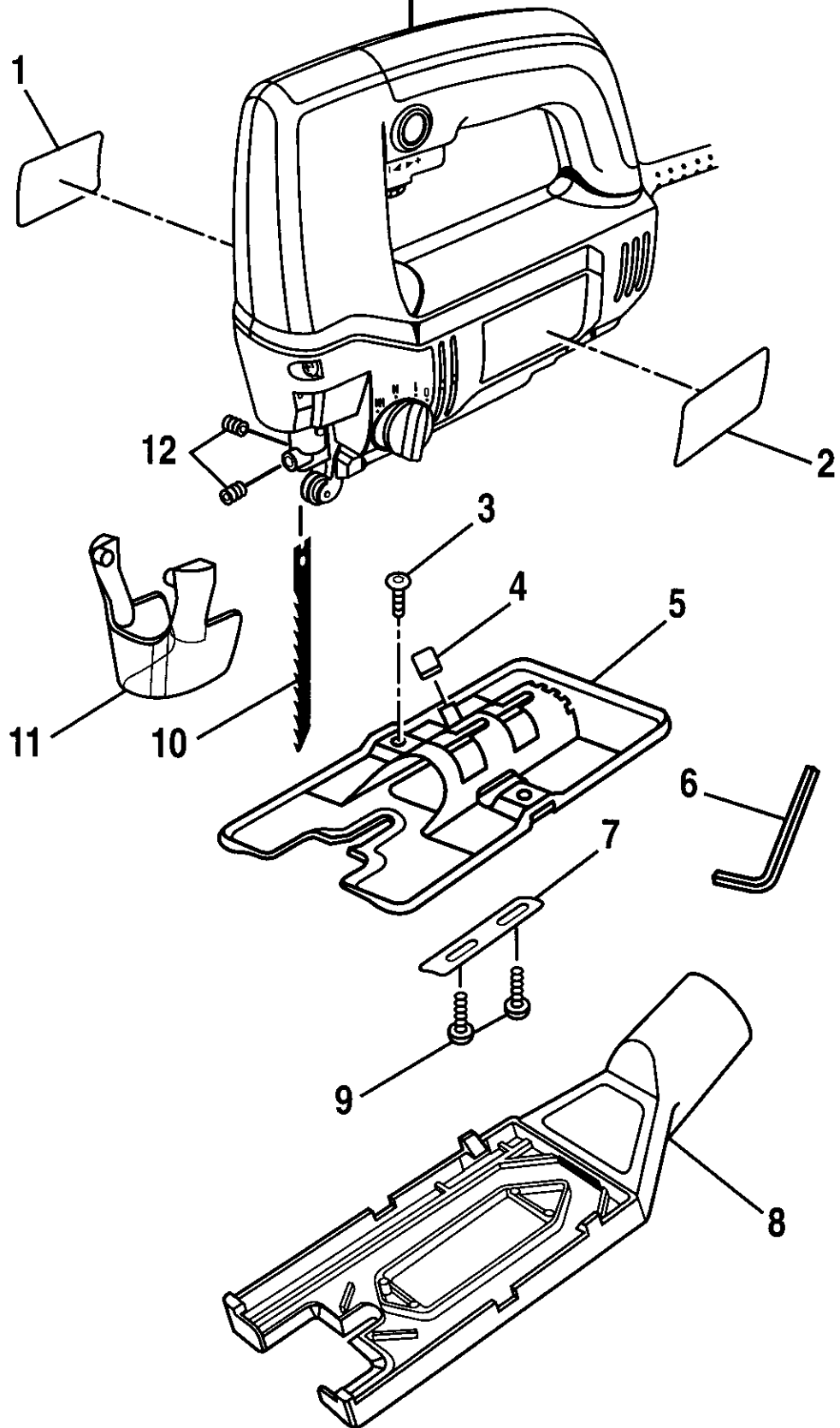

CRAFTSMAN ORBITAL ACTION SABRE SAW – MODEL NUMBER 315.172281

The model number will be found on a plate attached to the motor housing. Always mention the model number in all correspondence regarding your **SABRE SAW** or when ordering repair parts.

SEE BACK PAGE FOR PARTS ORDERING INSTRUCTIONS

PARTS LIST

Key No.	Part Number	Description	Quan.
1	982812-001	Data Plate	1
2	975685-001	Logo Plate	1
3	974321-001	* Screw (#10-24 x 3/8 in. Button Hd.)	1
4	975083-001	Rubber Tube	1
5	974308-003	Base Assembly	1
6	820193-005	1/8 in. Hex Allen Wrench	1
7	975683-001	Clamp - Plate	1
8	975682-000	Vacuum Attachment	1
9	974321-002	* Screw (#10-24 x 1/2 in. Button Hd.)	2
10	***	Saw Blade	1
11	974312-001	Chip Shield	1
12	970740-002	* Set Screw (#1/4-28 x 1/4 in. Hex Soc. Hd.)	2
13	975225-001	Optional Edge Guide (Not Shown)	1
	972000-902	Owner's Manual	

NOTE: "A" - The assembly shown represents an important part of the Double Insulated System. To avoid the possibility of alteration or damage to the System, service should be performed by your nearest Sears Repair Center. Contact your nearest Sears Catalog Order or Retail Store for Service Center information.

* Standard Hardware Item — May Be Purchased Locally
*** Complete Assortment Available At Your Nearest Sears Retail Store

Get it fixed, at your home or ours!

For repair of major brand appliances **in your own home...**
no matter who made it, no matter who sold it!

1-800-4-MY-HOMESM Anytime, day or night
(1-800-469-4663)

www.sears.com

To bring in products such as vacuums, lawn equipment and electronics
for repair, call for the location of your nearest **Sears Parts & Repair Center.**

1-800-488-1222 Anytime, day or night

www.sears.com

For the replacement parts, accessories and owner's manuals
that you need to do-it-yourself, call **Sears PartsDirectSM!**

1-800-366-PART 6 a.m. – 11 p.m. CST,
(1-800-366-7278) 7 days a week

www.sears.com/partsdirect

To purchase or inquire about a Sears Service Agreement:

1-800-827-6655

7 a.m. – 5 p.m. CST, Mon. – Sat.

Para pedir servicio de reparación a domicilio,
y para ordenar piezas con entrega a domicilio:

1-888-SU-HOGARSM
(1-888-784-6427)

Au Canada pour service en français:

1-877-LE-FOYERSM
(1-877-533-6937)

