

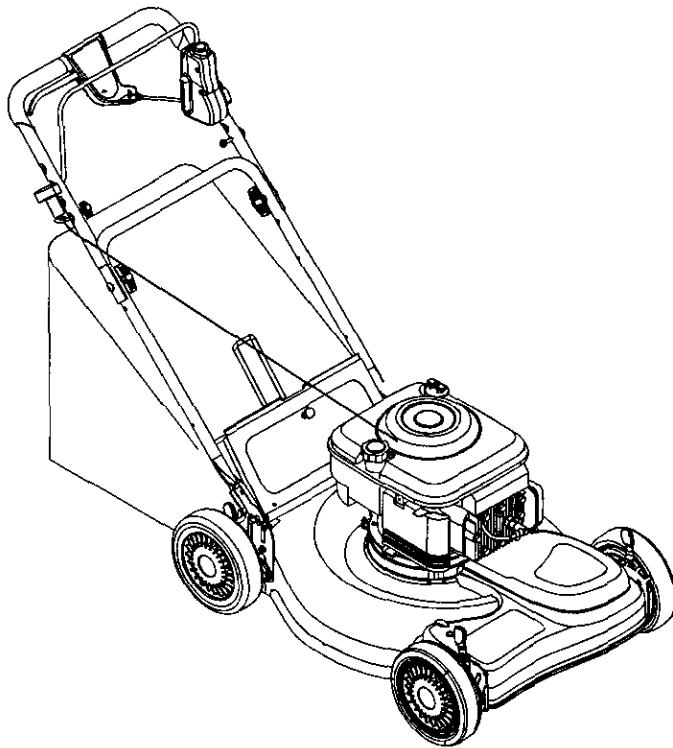

Operator's Manual



21" Self Starter Rear-Discharge Lawn Mower

Model Series

12A-449T402

IMPORTANT: Read safety rules and instructions carefully before operating equipment.

Warning: This unit is equipped with an internal combustion engine and should not be used on or near any unimproved forest-covered, brush-covered or grass-covered land unless the engine's exhaust system is equipped with a spark arrester meeting applicable local or state laws (if any). If a spark arrester is used, it should be maintained in effective working order by the operator. In the State of California the above is required by law (Section 4442 of the California Public Resources Code). Other states may have similar laws. Federal laws apply on federal lands. A spark arrester for the muffler is available through your nearest engine authorized service dealer or contact the service department, P.O. Box 368022 Cleveland, Ohio 44136-9722.

MTD PRODUCTS INC. P.O. BOX 368022 CLEVELAND, OHIO 44136-9722

ECO #

PRINTED IN U.S.A.

FORM NO. 770-10545.fm
(4/2001)

TABLE OF CONTENTS

Content	Page
Important Safe Operation Practices.....	3
Slope Gauge.....	6
Unpacking.....	7
Assembling Your Lawn Mower.....	7
Know Your Lawn Mower.....	10
Operating Your Lawn Mower.....	10
Maintaining Your Lawn Mower.....	13
Servicing Your Lawn Mower.....	14
Making Adjustments.....	16
Off- Season Storage.....	17
Troubleshooting.....	18
Parts List.....	20

FINDING MODEL NUMBER

This Operator's Manual is an important part of your new Lawn Mower. It will help you assemble, prepare and maintain the unit for best performance. Please read and understand what it says.



Before you start assembling your new equipment, please locate the model plate on the equipment and copy the information from it in the space provided below. The information on the model plate is very important if you need help from our Customer Support Department or an authorized dealer.

- You can locate the model number by standing behind the unit in the operating position and looking down at the rear of the deck. A sample model plate is explained below. For future reference, please copy the model number and the serial number of the equipment in the space below.

(Model Number) _____ (Serial Number) _____

MTD *For A Greener World* **MTD PRODUCTS INC**
CLEVELAND, OHIO 44136

Copy the model number here: _____

Copy the serial number here: _____

CALLING CUSTOMER SUPPORT

If you have difficulty assembling this product or have any questions regarding the controls, operation or maintenance of this unit, please call the Customer Support Department.



Call **1- (330) 220-4MTD** (4683) or **1- (800)-800-7310** to reach a Customer Support representative. Please have your unit's model number and serial number ready when you call. See previous section to locate this information. You will be asked to enter the serial number in order to process your call.

For more details about proper lawn care, visit our website at www.mtdproducts.com

SECTION 1: IMPORTANT SAFE OPERATION PRACTICES



WARNING: This symbol points out important safety instructions which, if not followed, could endanger the personal safety and/or property of yourself and others. Read and follow all instructions in this manual before attempting to operate this machine. Failure to comply with these instructions may result in personal injury. When you see this symbol—HEED ITS WARNING.



WARNING: Engine exhaust, some of its constituents, and certain vehicle components contain or emit chemicals known to State of California to cause cancer and birth defects or other reproductive harm.



WARNING: This machine was built to be operated according to the rules for safe operation in this manual. As with any type of power equipment, carelessness or error on the part of the operator can result in serious injury. This machine is capable of amputating hands and feet and throwing objects. Failure to observe the following safety instructions could result in serious injury or death.

General Operation

1. Read this operator's manual carefully in its entirety before attempting to assemble this machine. Read, understand, and follow all instructions on the machine and in the manual(s) before operation. Be completely familiar with the controls and the proper use of this machine before operating it. Keep this manual in a safe place for future and regular reference and for ordering replacement parts.
2. This machine is a precision piece of power equipment, not a plaything. Therefore, exercise extreme caution at all times. Your unit has been designed to perform one job: to mow grass. Do not use it for any other purpose.
3. Never allow children under 14 years old to operate this machine. Children 14 years old and over should read and understand the operation instructions and safety rules in this manual and should be trained and supervised by a parent. Only responsible individuals who are familiar with these safe operation rules should use this machine.
4. Thoroughly inspect the area where the equipment is to be used. Remove all stones, sticks, wire, bones, toys and other foreign objects which could be tripped over or picked up and thrown by the blade. Thrown objects can cause serious personal injury. Plan your mowing pattern to avoid discharge of material toward roads, sidewalks, bystanders and the like. Also, avoid discharging material against a wall or obstruction which may cause discharged material to ricochet back toward the operator.
5. To help avoid blade contact or a thrown object injury, stay in the operator zone behind the handles and keep bystanders, helpers, children and pets at least 75 feet from the machine while it is in operation. Stop machine if anyone enters the area.
6. Always wear safety glasses or safety goggles during operation and while performing an adjustment or repair to protect your eyes. Thrown objects which ricochet can cause serious injury to the eyes.
7. Wear sturdy, rough-soled work shoes and close-fitting slacks and shirts. Shirts and pants that cover the arms and legs and steel-toed shoes are recommended. Never operate this machine in bare feet, sandals, slippery or light weight (e.g. canvas) shoes.
8. Do not put hands or feet near rotating parts or under the cutting deck. Contact with the blade can amputate hands and feet.
9. A missing or damaged discharge cover can cause blade contact or thrown object injuries.
10. Many injuries occur as a result of the mower being pulled over the foot during a fall caused by slipping or tripping. Do not hold on to the mower if you are falling; release the handle immediately.
11. Never pull the mower back toward you while you are walking. If you must back the mower away from a wall or obstruction first look down and behind to avoid tripping and then follow these steps:
 - a. Step back from the mower to fully extend your arms.
 - b. Be sure you are well balanced with sure footing.
 - c. Pull the mower back slowly, no more than half way toward you.
 - d. Repeat these steps as needed.
12. Do not operate the mower while under the influence of alcohol or drugs.
13. Do not engage the self-propelled mechanism on units so equipped while starting engine.
14. The blade control handle is a safety device. Never attempt to bypass its operation. Doing so makes the safety device inoperative and may result in personal injury through contact with the rotating blade. The blade control handle must operate easily in both directions and automatically return to the disengaged position when released.
15. Never operate the mower in wet grass. Always be sure of your footing. A slip and fall can cause serious personal injury. If you feel you are losing your footing, release the blade control handle immediately and the blade will stop rotating within three seconds.
16. Mow in daylight or good artificial light. Walk, never run.
17. Stop the blade when crossing gravel drives, walkways or roads.
18. If the equipment should start to vibrate abnormally, stop the engine and check immediately for the cause. Vibration is generally a warning of trouble.
19. Shut the engine off and wait until the blade comes to a complete stop before removing the grass catcher or unclogging the chute. The cutting blade continues to rotate for a few seconds after the engine is shut off. Never place any part of the body in the blade area until you are sure the blade has stopped rotating.

20. Never operate mower without proper trail shield, discharge cover, grass catcher, blade control handle or other safety protective devices in place and working. Never operate mower with damaged safety devices. Failure to do so, can result in personal injury.
21. Muffler and engine become hot and can cause a burn. Do not touch.
22. Only use parts and accessories made for this machine by the original equipment manufacturer (O.E.M). Failure to do so can result in personal injury.
23. If situations occur which are not covered in this manual, use care and good judgment. Contact your dealer for assistance. Telephone 1-800-800-7310 for the name of your nearest dealer.

Slope Operation

Slopes are a major factor related to slip and fall accidents which can result in severe injury. Operation on slopes requires extra caution. If you feel uneasy on a slope, do not mow it. Before operating this unit on a slope or hilly area, use the slope gauge on page 6 to measure slopes. If the slope is greater than 15 degrees, do not mow it.

Do:

1. Mow across the face of slopes; never up and down. Exercise extreme caution when changing direction on slopes.
2. Watch for holes, ruts, rocks, hidden objects, or bumps which can cause you to slip or trip. Tall grass can hide obstacles.
3. Always be sure of your footing. A slip and fall can cause serious personal injury. If you feel you are losing your balance, release the blade control handle immediately, and the blade will stop rotating within 3 seconds.

Do Not:

1. Do not mow near drop-offs, ditches or embankments, you could lose your footing or balance.
2. Do not mow slopes greater than 15 degrees as shown on the slope gauge.
3. Do not mow on wet grass. Unstable footing could cause slipping.

Children

Tragic accidents can occur if the operator is not alert to the presence of children. Children are often attracted to the mower and the mowing activity. They do not understand the dangers. Never assume that children will remain where you last saw them.

1. Keep children out of the mowing area and under the watchful care of a responsible adult other than the operator.
2. Be alert and turn mower off if a child enters the area.
3. Before and while moving backwards, look behind and down for small children.
4. Use extreme care when approaching blind corners, doorways, shrubs, trees, or other objects that may obscure your vision of a child who may run into the mower.

5. Keep children away from hot or running engines. They can suffer burns from a hot muffler.
6. Never allow children under 14 years old to operate a power mower. Children 14 years old and over should read and understand the operation instructions and safety rules in this manual and should be trained and supervised by a parent.

Service

Safe Handling of Gasoline:

1. To avoid personal injury or property damage use extreme care in handling gasoline. Gasoline is extremely flammable and the vapors are explosive. Serious personal injury can occur when gasoline is spilled on yourself or your clothes which can ignite.
2. Wash your skin and change clothes immediately.
3. Use only an approved gasoline container.
4. Never fill containers inside a vehicle or on a truck or trailer bed with a plastic liner. Always place containers on the ground away from your vehicle before filling.
5. If possible, remove gas-powered equipment from the truck or trailer and refuel it on the ground. If this is not possible, then refuel such equipment on a trailer with a portable container, rather than from a gasoline dispenser nozzle.
6. Keep the nozzle in contact with the rim of the fuel tank or container opening at all times until fueling is complete. Do not use a nozzle lock-open device.
7. Extinguish all cigarettes, cigars, pipes and other sources of ignition.
8. Never fuel machine indoors because flammable vapors will accumulate in the area.
9. Never remove gas cap or add fuel while the engine is hot or running. Allow engine to cool at least two minutes before refueling.
10. Never over fill fuel tank. Fill tank to no more than ½ inch below bottom of filler neck to provide space for fuel expansion.
11. Replace gasoline cap and tighten securely.
12. If gasoline is spilled, wipe it off the engine and equipment. Move unit to another area. Wait 5 minutes before starting the engine.
13. Never store the machine or fuel container inside where there is an open flame, spark or pilot light as on a water heater, space heater, furnace, clothes dryer or other gas appliances.
14. To reduce fire hazard, keep mower free of grass, leaves, or other debris build-up. Clean up oil or fuel spillage and remove any fuel soaked debris.
15. Allow a mower to cool at least 5 minutes before storing.

General Service:

1. Never run an engine indoors or in a poorly ventilated area. Engine exhaust contains carbon monoxide, an odorless and deadly gas.
2. Before cleaning, repairing, or inspecting, make certain the blade and all moving parts have stopped. Disconnect the spark plug wire and ground against the engine to prevent unintended starting.

3. Check the blade and engine mounting bolts at frequent intervals for proper tightness. Also, visually inspect blade for damage (e.g., bent, cracked, worn) Replace blade with the original equipment manufacturer's (O.E.M.) blade only, listed in this manual. "Use of parts which do not meet the original equipment specifications may lead to improper performance and compromise safety!"
4. Mower blades are sharp and can cut. Wrap the blade or wear gloves, and use extra caution when servicing them.
5. Keep all nuts, bolts, and screws tight to be sure the equipment is in safe working condition.
6. Never tamper with safety devices. Check their proper operation regularly.
7. After striking a foreign object, stop the engine, disconnect the spark plug wire and de-energize the starter. (See section "To De-energize Self Starter". Thoroughly inspect the mower for any damage. Repair the damage before starting and operating the mower.
8. Never attempt to make a wheel or cutting height adjustment while the engine is running.
9. Grass catcher components, discharge cover, and trail shield are subject to wear and damage which could expose moving parts or allow objects to be thrown. For safety protection, frequently check components and replace immediately with original equipment manufacturer's (O.E.M.) parts only, listed in this manual. "Use of parts which do not meet the original equipment specifications may lead to improper performance and compromise safety!"
10. Do not change the engine governor setting or overspeed the engine. The governor controls the maximum safe operating speed of the engine.
11. Maintain or replace safety and instruction labels, as necessary.
12. Observe proper disposal laws and regulations. Improper disposal of fluids and materials can harm the environment.
13. ALWAYS de-energize self starter prior to performing any maintenance or service to the engine and or mower. Follow instructions both in the manual and on the engine and or machine to de-energize starter.

Your Responsibility

- Restrict the use of this power machine to persons who read, understand and follow the warnings and instructions in this manual and on the machine.

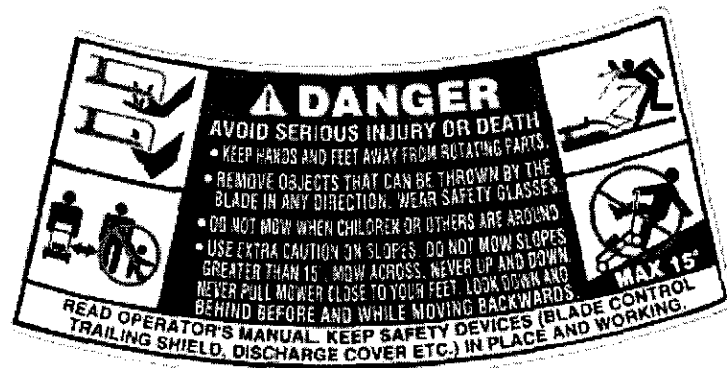

SECTION 2: SLOPE GAUGE

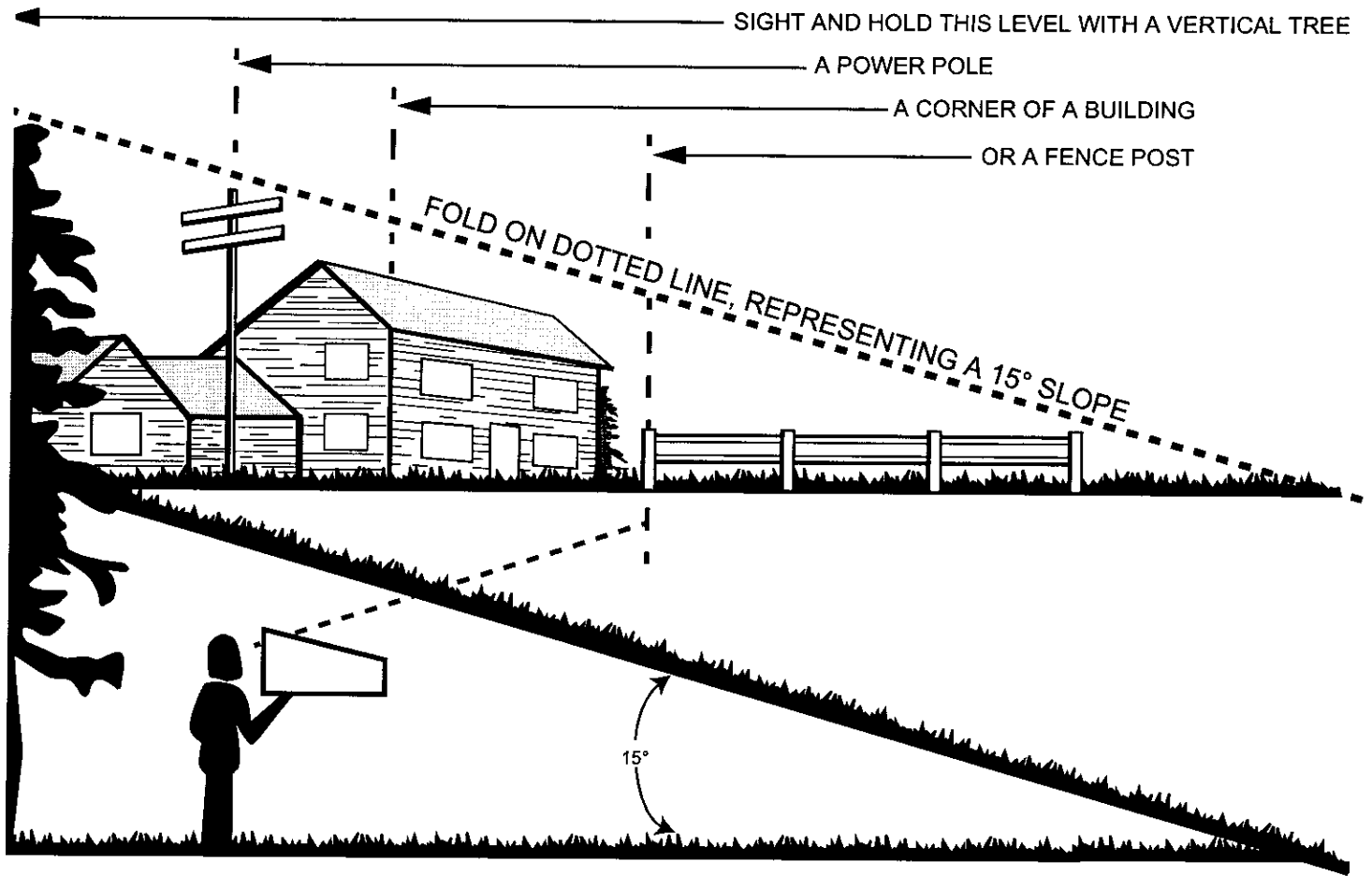

Do not mow on inclines with a slope in excess of 15 degrees (a rise of approximately 2-1/2 feet every 10 feet). A riding mower could overturn and cause serious injury. If operating a walk-behind mower on such a slope, it is extremely difficult to maintain your footing and you could slip, resulting in serious injury.

Operate RIDING mowers up and down slopes, never across the face of slopes.

Operate WALK-BEHIND mowers across the face of slopes, never up and down slopes.

SECTION 3: UNPACKING

Removing Unit From Carton

- Remove staples, break glue on top flaps or cut tape at carton end and peel along top flap to open carton.
- Remove loose parts if included with unit (i.e., operator's manual, hardware pack etc.).
- Cut corners and lay carton down flat. Remove packing material.
- Roll or slide unit out of carton. Check carton thoroughly for loose parts.

SECTION 4: ASSEMBLING YOUR LAWN MOWER

NOTE: Make sure not to crimp the cables while removing the loose parts or the entire unit from the carton.

NOTE: Reference to right or left hand side of the mower is observed from the operating position.

Tools Required

- Pair of Pliers
- Funnel
- Set of adjustable wrenches



WARNING: Disconnect the spark plug wire and ground it against the engine to prevent unintended starting. Leave safety key in locked position.

Disconnecting Spark Plug

- Before setting up your lawn mower, disconnect the spark plug wire from the spark plug, and ground it to a bolt, retaining post or V-slot on the engine. See Figure 1.

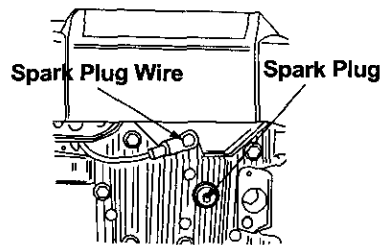

Figure 1

Assembling Handle

- For shipping purposes, the grass bag was placed on top of the unit. Remove it from the unit and set it out of the way. See Figure 2.

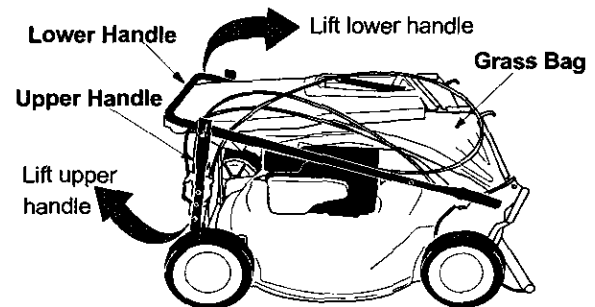

Figure 2

- Raise the lower handle, as shown in Figure 2, until it snaps into place.
- Raise the upper handle as shown in Figure 2.
- Tighten the two wing nuts which are already on the handle. See Figure 3.

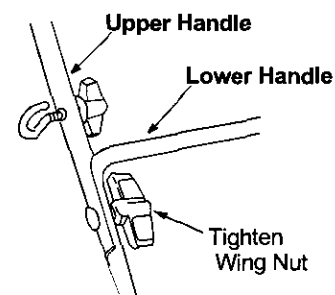

Figure 3

NOTE: Make sure to route the cables outside the lower handle. Also do not crimp the cables while lifting the handle up.

- For shipping purposes, the hairpin clip is placed in the outer hole of the weld pin on the lower handle. Remove the hairpin clip from the outer hole of the weld pin.

- Using a pair of pliers, insert the hairpin clip into the inner hole in the weld pin. Repeat on the other side. See Figure 4.

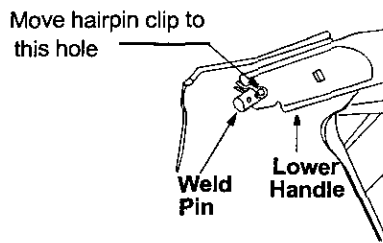

Figure 4

- Insert post of cable ties that are on lower handle into the holes provided on the lower handle. The holes may be on the inside or outside. Pull cable ties tight and cut off the extra. See Figure 5 below.

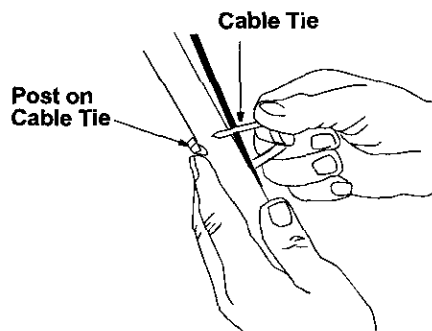

Figure 5

Attaching Starter Rope

The rope guide is already attached to the right side of the upper handle of your mower. See Figure 6.

- With the spark plug wire disconnected and grounded, and with the safety key in the locked position, pull the starter rope up to the rope guide. See Figure 6.
- Slip the rope through the rope guide as shown below. Tighten the wing nut holding the rope guide to the upper handle.

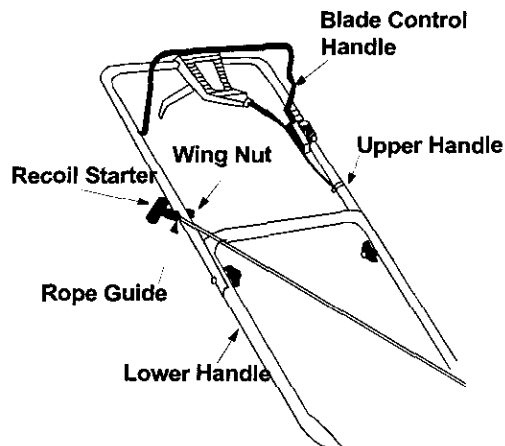

Figure 6

Grass Catcher Assembly

NOTE: Make certain the grass bag is turned right side out before assembling (warning label will be on the outside).

Soft Grass Bag

Parts for soft grass bag:

- Front Frame
- Rear Frame
- Bag

Assembling soft grass bag:

- Join the rear frame and front frame assembly as shown in Figure 7A.
- Place the bag over the frame (black plastic side is the bottom of bag). Slip the openings in the side of the plastic channels on the bag over the hooks on the grass catcher frame.
- Secure bag to frame by working the plastic channels on bag over frame as shown in Figure 7B. All of the plastic channels except the center top of the bag attach from the outside of bag. The center top of the bag attaches from inside the bag.

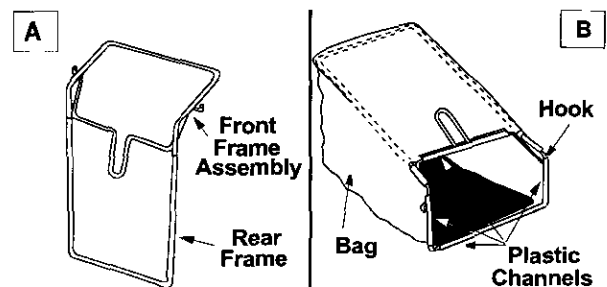

Figure 7

Attaching Grass Catcher

- If your mower is equipped with a mulching plug, and it is in place on the mower, lift the rear discharge door and remove the rear mulching plug from the mower. See Figure 8.

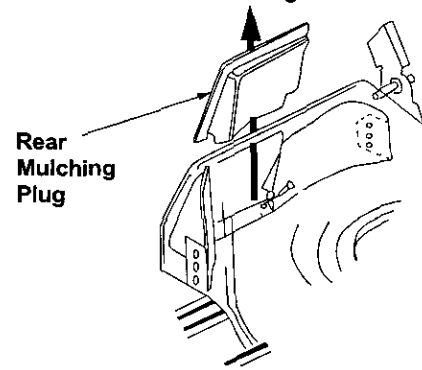

Figure 8

NOTE: Make sure that the cables are routed to the outside of the handle when attaching the grass catcher.

- Lift the rear discharge door.
- Place the hooks of the grass catcher into the slots in the handle bracket assemblies on both sides. See Figure 9. Release the rear discharge door.

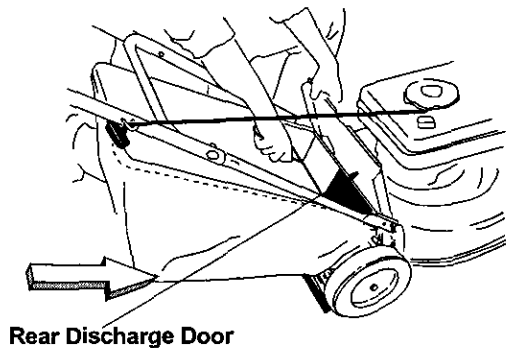

Figure 9

Removing Grass Catcher

- Lift the rear discharge door on the mower.
- Lift the grass catcher up, out of the slots in the handle bracket assemblies.
- Reinstall the plastic rear mulching baffle.
- Release the rear discharge door.



WARNING: Never operate the mower unless the hooks on the grass catcher are seated in the slots on the handle bracket assemblies, and the rear discharge door rests firmly against the top of the grass catcher.

Chute Deflector (If equipped)

If your mower is equipped with the chute deflector, assemble as follows:

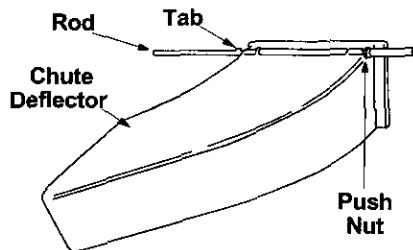

Figure 10

- Slide the rod into the upper edge of the chute deflector so the tab on the rod is toward the left side of the chute deflector. When assembled correctly, the rod will extend further to the left side than the right side. See Figure 10.
- Slide the push nut onto the right side of the rod to secure.

Attaching Chute Deflector

- Lift the rear discharge door on the mower.
- Place the ends of the rod into the slots in the handle bracket assemblies. See Figure 11.
- Release the rear discharge door.

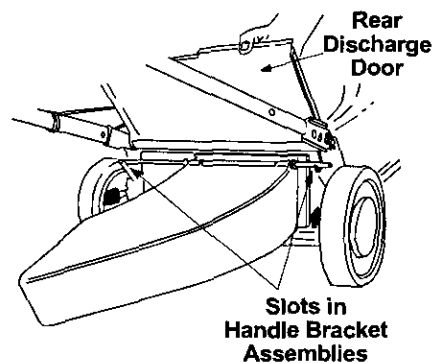

Figure 11

Converting to Mulcher

- Lift the rear discharge door.
- Remove the grass bag or chute deflector.
- Insert the mulch plug. See Figure 8.
- Release the rear discharge door. See Figure 9.

SECTION 5: KNOW YOUR LAWN MOWER



WARNING: Be familiar with all controls and their proper operation. Know how to stop the machine and disengage them quickly.

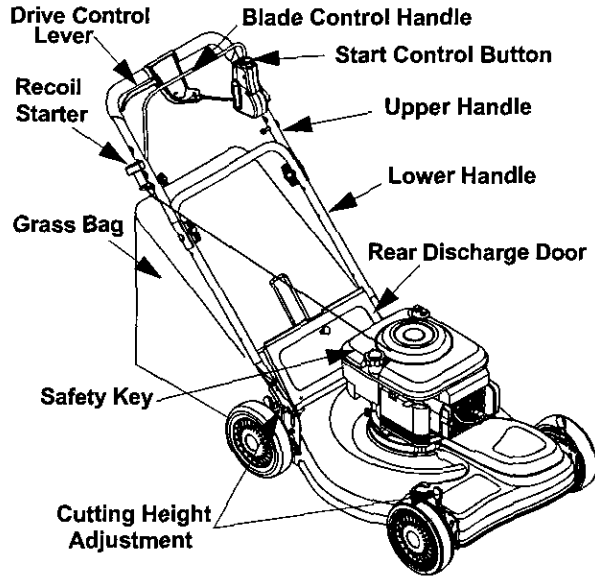

Figure 12

Recoil Starter

The recoil starter handle is attached to the upper handle. See Figure 12. The recoil starter is used to start the engine when the self starter is in the de-energized mode.

Primer

The primer is used to pump gas into the carburetor. Use it to assist in starting a cold engine, but do not use it when restarting a warm engine after a short shutdown. Refer to engine manual for location of the primer.

Blade Control Handle

The blade control handle is located on the upper handle of the mower. The blade control handle and starter control button must be depressed in order to operate the unit. Release the blade control handle to stop the engine and the blade and to energize the self starter.



WARNING: The blade control handle is a safety device. Never attempt to bypass its operations. Doing so, may result in personal injury through contact with the rotating blade. The blade rotates whenever the engine is running and when the self starter is de-energized.

Drive Clutch Control

The drive control lever is located on the upper handle and is used to engage the drive. Squeeze the lever against the upper handle to engage the drive; release the drive control lever to slow down or stop the mower from propelling.

Safety Key

The safety key is located on the engine. See Figure 12. The safety key is a safety device used to activate and deactivate the self starter system. The self starter system will not work without the key in its proper position. See engine manual for further information pertaining to the safety key.

NOTE: The safety key must be in the run position to start the mower for both systems, either the self starter or recoil starter.

Start Control Button

The start control button is located on the upper left side of the handle. See Figure 12. The start control button must be depressed fully while pulling the blade control handle toward the upper handle for the engine to start. The starter control button will automatically return to the off/up position once the blade control handle is released.

NOTE: The starter button must be depressed to start the engine with either the self starter or recoil starting system.

SECTION 6: OPERATING YOUR LAWN MOWER



WARNING: Read, understand, and follow all instructions and warnings on the machine and in this manual before operating.

Keep hands and feet away from the discharge area on and from under the cutting deck. See safety labels on page 5.

The operation of any lawn mower can result in foreign objects being thrown into the eyes, which can result in severe eye damage. Always wear safety glasses or eye shields.

NOTE: For best results raise the cutting position until it is determined which height is best for your lawn. See Cutting Height Adjustment Section.

Gas and Oil Fill-Up



WARNING: Use extreme care when handling gasoline. Gasoline is extremely flammable and the vapors are explosive. Never fuel machine indoors or while the engine is hot or running. Extinguish cigarettes, cigars, pipes, and other sources of ignition.

- Service the engine with gasoline and oil as instructed in the separate engine manual packed with your mower. Read the instructions carefully.

Before Starting Mower



WARNING: Read, understand, and follow all instructions and warnings on the machine and in this manual before operating.

- Attach spark plug wire to spark plug. Make certain the metal cap on the end of the spark plug wire (inside the rubber boot) is fastened securely over the metal tip on the spark plug.
- Check the drive clutch control for proper adjustment. If the mower does not propel itself or the drive wheels hesitate with the drive clutch engaged, perform the drive clutch control adjustment as instructed on page 16.

First Time Starting Engine

NOTE: Use recoil starter rope to start engine for the very first time. The mower is shipped with the safety key in the locked position and the self starter in the de-energized mode, follow instructions as follows.

1. Place lawn mower on a level surface outdoors.
2. Remove clear plastic packaging under fuel cap.
3. Check oil level.
4. Add fuel.
5. Open shut off valve (if equipped) 1/4 turn.
6. Push spark plug wire firmly on spark plug.
7. Turn safety key 1/4 turn clockwise to RUN position.
8. Make sure that the drive clutch control is adjusted so the drive belt is as loose as possible.
9. Push the primer three times.
10. While standing in the operating position, depress the starter control button fully with the thumb of your right hand.
11. Using your left hand, pull the blade control handle all the way toward the upper handle. See Figure 13.
12. Release the button.
13. Grasp the recoil rope starter handle with your right hand and slowly pull towards you until feel a slight resistance, then pull firmly until your arm is fully extended.

14. If engine does not start by the second pull, repeat steps 8, 9, 10, 11 and 12.

Second Time Starting Engine

NOTE: Follow these instructions if the self starter is already in the energized mode.



WARNING: NEVER assume starter is in the de-energized mode, even if the key is in the locked position and/or removed from the engine. ALWAYS de-energize starter prior to performing any maintenance or service to the engine and/or mower. Follow instructions on the engine and/or machine to de-energize.

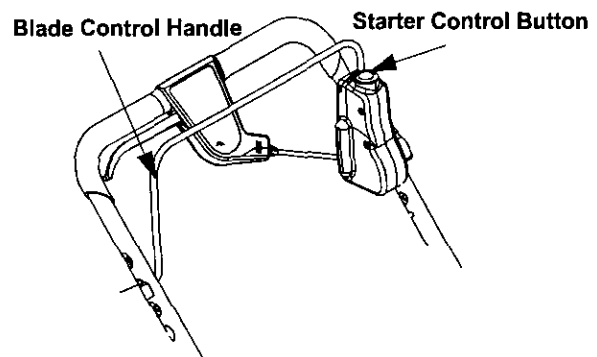

Figure 13

1. Check oil level and add fuel, if necessary.
2. Open shut off valve (if equipped) 1/4 turn.
3. Turn safety key 1/4 turn clockwise to RUN position.
4. Firmly push primer bulb 3 times (for a cold engine only!).
5. While standing at the upper handle, depress the starter control button with the thumb of your right hand.
6. Using your left hand, pull the blade control handle all the way toward the upper handle. See Figure 13. Starter will de-energize and engine will start. (NOTE: if engine does not start, release the blade control handle and follow steps 8, 9, 10, 11 and 12 in the "First Time Starting Engine instructions).

NOTE: If any problems are encountered, refer to the Trouble Shooting Guide for helpful information.

To Stop Engine and Blade



WARNING: The blade will continue to rotate for three seconds after the blade control lever is released.

1. Release safety blade control handle (the start control button will automatically return to the off/up position), engine and blade will stop within a few seconds.

NOTE: Engine may stop with a racking sound. This sound is the self starter being reactivated/energized for the next start.

2. Turn safety key 1/4 turn counterclockwise to LOCK position. Remove key and store in a safe place.

To De-Energize Self Starter

- Remove spark plug wire from spark plug.
- Turn safety key to RUN position (1/4 turn clockwise).
- While standing in the operating position, depress the starter control button fully with the thumb of your right hand.
- Using your left hand, pull the control handle all the way toward the upper handle. (Release button and wait until blade and starter stop rotating.)
- Release safety blade control handle (the start control button will automatically return to the off/up position).
- Remove safety key.

NOTE: Engine will crank over upon actuating equipment starting controls, but will not spark if spark plug wire was removed from spark plug as described above. Once engine has stopped cranking, self starter is de-energized.



WARNING: Self Starting System: If these instructions are not followed, amputation or severe laceration can result.

- ALWAYS disconnect spark plug, de-energize starter, lock and remove safety key BEFORE performing ANY service to the engine or mower.
- DO NOT attempt any maintenance or repairs to the self starter.
- NEVER assume starter is de-energize, even if key is in LOCK AND REMOVE position and/or removed from engine.
- BEFORE removing grass or other debris from under mower deck; BEFORE changing oil, air filter or spark plug; BEFORE removing blade for servicing; BEFORE performing any other service to engine or mower; BEFORE transporting mower- ALWAYS DE-ENERGIZE SELF STARTER.
- ALWAYS lock and remove safety key and store in a safe place until next use. The safety key is designed and intended to be removed from engine when not in use. Removing key will prevent unsupervised or unexpected starting of mower by children or unsuspecting adults. The safety key must be in the locked position before it can be removed.

Using Your lawn Mower

- **Do not** operate the mower without the mulching cover, the grass catcher bag, or the discharge chute properly installed.
- Be sure that the lawn is clear of stones, sticks, wire, or other objects which could damage lawn mower or engine. Such objects could be accidentally thrown by the mower in any direction and cause serious personal injury to the operator and others.
- For best results, *do not cut wet grass* because it tends to stick to the underside of the mower, preventing proper discharge of grass clippings, poor mulching conditions, and could cause you to slip and fall. New grass, thick grass, or wet grass may require a narrower cut.
- For a *healthy lawn*, always cut off one-third or less of the total length of the grass. Lawn should be trimmed in fall as long as there is growth.



WARNING: If you strike a foreign object, stop the engine. Remove spark plug wire from spark plug, thoroughly inspect the mower for any damage. Repair the damage before restarting and operating the mower. Extensive vibration of the mower during operation is an indication of damage. The unit should be promptly inspected and repaired.

Bagging Grass Clippings

You can use the grass catcher bag to collect clippings while you are operating the mower. Attach the grass catcher following instructions on page 8 of this manual. The grass clippings will automatically collect in the bag as you run the mower. Operate the mower until the grass bag is full. Do NOT allow the bag to overfill with grass clippings.

- Stop the engine completely by releasing the control handle.
- Make sure that the unit has come to a complete stop.
- Lift discharge door and pull grass bag up and away from the mower to dispose of the grass clippings See Figure 14.

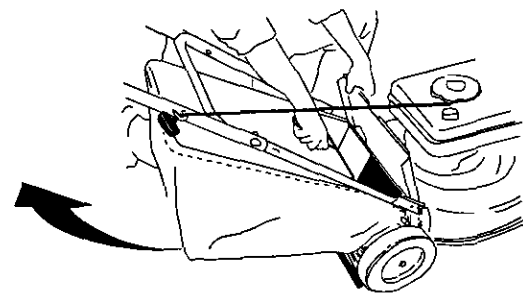

Figure 14

Adjusting Cutting Height

Refer to height adjustments section of this manual on

page 17 for instruction on how to adjust the cutting height and the handle height.

- For best results in mowing, keep the cutting height position high until you have determined which cutting height is preferred.

SECTION 7: MAINTAINING YOUR LAWN MOWER



WARNING: Be sure to disconnect the spark plug wire and DE-ENERGIZE starter before performing any repairs or maintenance. DO NOT attempt any maintenance or service to the engine and/or mower equipped with the safety key in the unlocked and/or energized mode.



WARNING: NEVER assume starter is de-energized, even if the key is in the locked position and/or removed from the engine. ALWAYS de-energize self starter prior to performing any maintenance or service to the engine and/or mower. Follow instructions on the engine and/or machine to de-energize starter.

Cleaning Mower

- Clean the underside of the mower deck after each use to prevent any build-up of grass clippings. If this debris is allowed to accumulate, it will result in rust and corrosion.

NOTE: We do not recommend the use of pressure washers or garden hose to clean your unit. These may cause damage to electric components, spindles, pulleys, bearings or the engine. The use of water will result in shortened life and reduced serviceability.

- Disconnect spark plug wire.
- Drain the gasoline from the lawn mower, or place a piece of plastic under the gas cap.
- Tilt the mower so that the side with the air cleaner is facing up. Hold the mower firmly.
- Scrape and clean the underside of the deck with a suitable tool. Do not spray with water.
- Put the mower back on its wheels. If you had put plastic under the gas cap, remove it now.



WARNING: Never tip the mower more than 90 degrees in any direction and do not leave the mower tipped for any length of time. Oil can drain into the upper part of the engine causing a starting problem.

Engine Maintenance

A list of key maintenance jobs required for good performance by the mower is given below. Follow the accompanying engine manual for detailed list and instructions.

- Change engine oil after the first two operating hours and every 25 operating hours thereafter. Check the oil level before starting the engine every time.
- Service foam filter in the air cleaner every 25 hours of use and replace the paper filter component every 100 hours. You may have to service the air filter more frequently if you are operating the mower under extremely dusty conditions.
- Clean engine periodically. Remove dirt and debris with a cloth or brush.
- Clean the spark plug and reset the gap to .030" at least once a season or every 50 hours of operation. Spark plug replacement is recommended at the start of each season.
- Inspect muffler periodically, and replace if necessary. Damaged mufflers or spark arresters can create a fire hazard. Make sure to avoid muffler and surrounding areas while the mower engine is hot because temperature of these areas of the engine may exceed 150° F.

Lubrication

Wheels

- Lubricate the wheels and bearings, if so equipped, at least once a season with light oil or engine oil. Also, if the wheels are removed for any reason, lubricate the surface of the axle bolt and the inner surface of the wheel with light oil.

Chute Deflector & Rear Discharge Door

- Lubricate the torsion spring and the pivot point on each end of the chute deflector and the rear discharge door using a light oil. This will prevent rusting and ensure that the deflector, which is a safety device, can always work properly.

Engine

- Follow the engine manual instructions and recommended schedule for lubricating engine components.

Transmission

- The transmission is pre-lubricated and sealed at the factory and does not require lubrication on a regular basis as part of maintenance. However, if you disassemble the transmission for any reason, refill with two ounces of Alvania grease (part # 737-0168A) as part of reassembly.

Pivot Points

- Lubricate the pivot points on the blade control handle, brake cable and the cutting height adjustment lever at least once a season with light oil. The blade control handle must operate freely in both directions. The cutting height adjustment levers should be able to move easily.

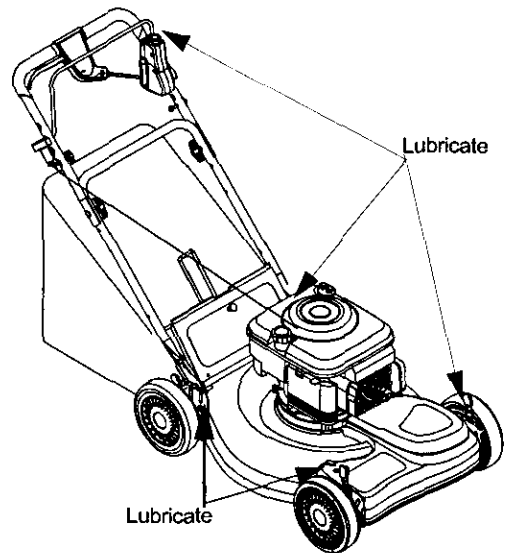

Figure 15

SECTION 8: SERVICING YOUR LAWN MOWER



WARNING: Be sure to disconnect the spark plug wire and DE-ENERGIZE starter before lubricating, repairing, or servicing. DO NOT attempt any maintenance or service to the engine and/or mower equipped with the safety key in the unlocked and/or energized mode.



WARNING: NEVER assume starter is de-energized, even if the key is in the locked position and/or removed from the engine. ALWAYS de-energize self starter prior to performing any maintenance or service to the engine and/or mower. Follow instructions on the engine and/or machine to de-energize starter.

Blade Care



WARNING: Periodically inspect the blade adapter and pulley for cracks, especially if you strike a foreign object. Replace when necessary.



WARNING: When removing the cutting blade for sharpening or replacement, protect hands by using heavy gloves or a thick rag to grasp the cutting blade.

- Disconnect spark plug wire from spark plug.
- Turn mower on its side making sure that the air filter and the carburetor are up.

To Remove Blade:

- Remove the bolt and the bell washer that hold the blade-pulley assembly to the engine crankshaft. See Figure 16. Remove the assembly from the crankshaft.
- Remove the two bolts and lock nuts from the blade assembly.
- Remove the blade from blade adapter and pulley.

To Replace Blade:

- Before reinstalling the blade-pulley assembly to the unit, lubricate the engine crankshaft and the inner surface of the blade adapter with light oil.
- Also lubricate the bolt holes, bolt and the inner surface of the nuts.

- Install the blade adapter on the pulley with the “star” away from the pulley. See Figure 16.

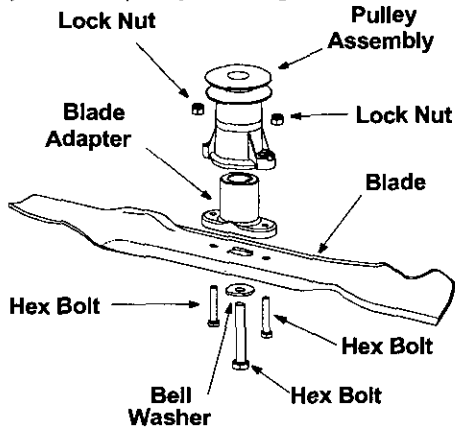

Figure 16

- Place the new blade on the blade adapter with the side marked bottom (has a part number) facing away from the adapter.
- Secure the blade to the assembly with two hex bolts and lock nuts. Tighten the hex bolts to the recommended torque. Refer to 'Blade Mounting Torque' information below.
- Install the blade assembly on the engine crankshaft. Secure with the hex bolt and bell washer (cupped side of washer to blade) and tighten to the recommended torque. Refer to 'Blade Mounting Torque' information below.

IMPORTANT: The bolt used to secure the blade to the engine is specially heat-treated. **Do not substitute.** To order replacement bolt, refer to the parts list in the back of this manual.



WARNING: To ensure safe operation of your unit, all nuts and bolts must be checked periodically for correct tightness.

Blade Mounting Torque:

Blade adapter bolts: 120 in.lbs. minimum, 150 in.lbs. maximum.

Center bolt: 450 in.lbs. minimum, 600 in.lbs. maximum.

To Sharpen Blade:

- The blade can be sharpened with a file or on a grinding wheel. Do not attempt to sharpen the blade while it is still on the mower.
- Follow the original angle of grind as a guide. Make sure that each cutting edge receives an equal amount of grinding to prevent an unbalanced blade.

An unbalanced blade will cause excessive vibration when rotating at high speeds, may cause damage to the mower and could break, and may causing personal injury. Test the blade by balancing it on a round shaft screwdriver or a blade balancer.

- If the blade is not balanced, remove metal from the heavy side until it balances evenly.

Replacing Drive Belt



WARNING: Disconnect the spark plug wire and ground it against the engine to prevent unintended starting. Drain fuel into an approved container or place a piece of plastic film underneath the gas cap to prevent gasoline from leaking.

- Remove the two shoulder screws securing the front drive cover to the mower deck. See Figure 17.
- Press inward on the sides of the front drive cover and release the tabs that secure the front drive cover to the height adjuster brackets. Remove drive cover from the mower.
- Remove the idler and hardware from idler bracket using 7/16" wrench and socket. See Figure 17.
- Remove the belt from the transmission pulley as shown in Figure 17.

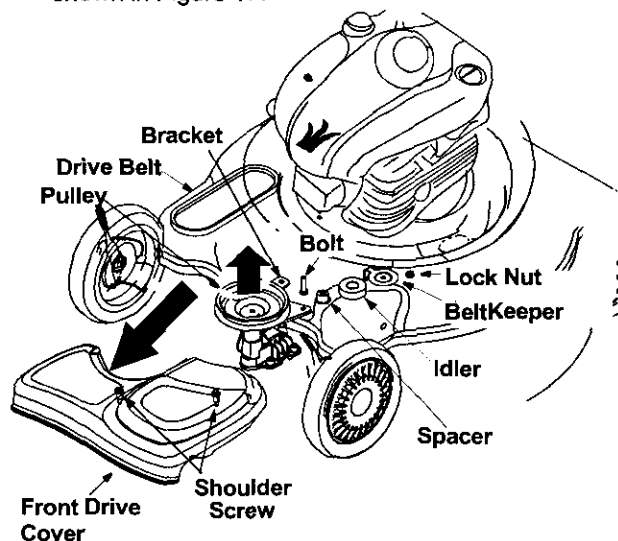

Figure 17

- Lift and stabilize the front of the deck.
- Loosen the center hex bolt and lower the blade and engine pulley until there is adequate clearance to move the belt past the belt keeper.
- Remove the belt from the engine pulley and around the blade. See Figure 18.
- Reassemble new belt (part # 754-0465). Begin idler reassembly by inserting bolt up through the idler bracket hole. Adjust the drive clutch following the instructions below.

NOTE: Torque center hex bolt to between 450 and 600 in. lbs.

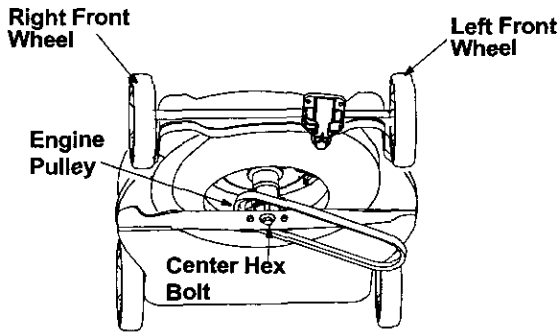

Figure 18

SECTION 9: MAKING ADJUSTMENTS



WARNING: Be sure to disconnect the spark plug wire and DE-ENERGIZE starter before performing any adjustments or repairs. DO NOT attempt any maintenance or service to the engine and/or mower equipped with the safety key in the unlocked and/or energized mode.



WARNING: NEVER assume starter is de-energized, even if the key is in the locked position and/or removed from the engine. ALWAYS de-energize self starter prior to performing any maintenance or service to the engine and/or mower. Follow instructions on the engine and/or machine to de-energize starter.

Adjusting Drive Clutch Control

- The drive clutch adjustment wheel is located on the drive control lever housing and is used to tighten or loosen tension on the drive cable. Perform this adjustment if the following exists.
 - a. The mower does not propel itself with the drive control lever engaged.
 - b. The mower's drive wheels hesitate with the drive control lever engaged.
- To resolve the above problems, rotate the adjustment wheel with your fingers: clockwise to tighten the cable, and counter-clockwise to loosen the cable. See Figure 19.

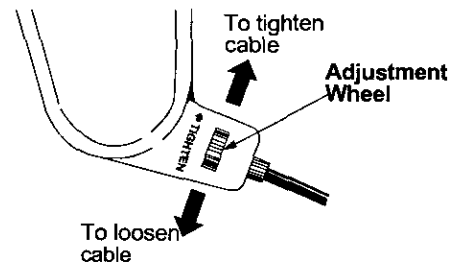

Figure 19

Adjusting Handle Height

Your mower is shipped with the handle in the higher height position. To lower height, proceed as follows.

- Remove the starter rope from the rope guide.
- Remove the upper handle by removing the hand knobs and carriage bolts. Lay the upper handle out of the way, being careful not to bend or kink the cables.
- Remove the hairpin clips from the weld pins on the handle brackets. Refer to Figure 4. Press out on the legs of the lower handle. Remove lower handle from the mower.
- Turn the lower handle around so the notch on the bottom of the lower handle is facing forward as shown in Figure 20. Reassemble, placing the bottom holes in the handle over the weld pins in the handle mounting bracket.
- Reassemble the upper handle to the lower handle.
- Insert hairpin clips in the inner holes of the weld pins and attach the starter rope as instructed in the "Assembling Your Lawn Mower" section.

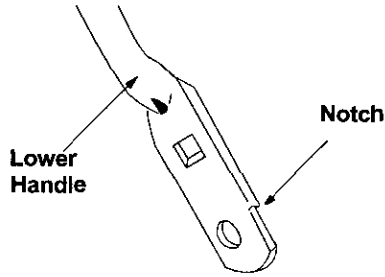

Figure 20

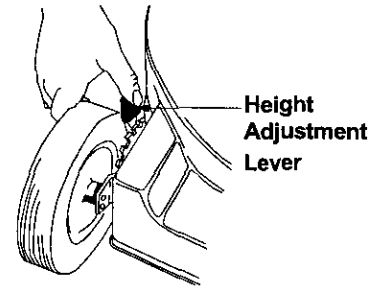

Figure 21

Adjusting Cutting Height

IMPORTANT: All wheels must be placed in the same relative position. For rough or uneven lawns, move the height adjustment lever to a higher position. This will help stop scalping of the grass.

An adjusting plate and thumb lever at each wheel position provides cutting height adjustment. Each adjusting plate has nine height positions. Height of cut will change when you move the thumb lever from one position to another.

- Simply depress the lever towards the wheel and move the lever assembly to desired position. See Figure 21.

Adjusting Carburetor



WARNING: If any adjustments are made to the engine (e.g. carburetor) while the engine is running, keep clear of all moving parts. Be careful of heated surfaces like the muffler.

NOTE: A dirty air cleaner may cause an engine to run rough too. Make sure that the air cleaner is clean and attached to the carburetor before deciding to adjust the carburetor.

To adjust carburetor, please follow the engine manual.

SECTION 10: OFF-SEASON STORAGE

Prepare your lawn mower for storage at the end of the season or if the unit will not be used for 30 days or more. Store the mower in a clean, dry area.



WARNING: Be sure to disconnect the spark plug wire and DE-ENERGIZE starter before performing any repairs or maintenance. DO NOT attempt any maintenance or service to the engine and/or mower equipped with the safety key in the unlocked and/or energized mode.



WARNING: NEVER assume starter is de-energized, even if the key is in the locked position and/or removed from the engine. ALWAYS de-energize self starter prior to performing any maintenance or service to the engine and/or mower. Follow instructions on the engine and/or machine to de-energize starter.



WARNING: Never store the machine or fuel container indoors where there is an open flame, spark or pilot light such as on water heater, furnace, clothes dryer or other gas appliance.

NOTE: We do not recommend the use of pressure washers or garden hose to clean your unit. They may cause damage to electric components, spindles, pulleys, bearings or the engine. The use of water will result in shortened life and reduce serviceability.

- Lubricate the mower as instructed on page 13.
- You can fold your mower's handle for convenience of storage:

Remove the starter rope from the rope guide; loosen the two hand knobs on the sides of the handle, and let the upper handle fold down to the rear.

Move the hairpin clips to the outer hole in the weld pins on the handle mounting brackets. Spread the sides of the lower handle, and push it forward and down.

- Inspect and replace/sharpen blade, if required. Refer to page 14.
- Replace your gasoline can if it starts to rust. Rust and/or dirt in the gasoline will cause problems. Store unit in a clean, dry area. Do not store next to corrosive materials, such as fertilizer or rocksalt.

NOTE: If storing the mower in an unventilated or metal storage shed, make sure to rustproof the equipment with a light oil or silicone.

Engine

- Clean engine and remove any grass clippings, dirt, and debris from the cooling fins, air intake screen, levers, linkage and the exterior of the engine.
- Follow recommendations in the accompanying engine manual for off-season storage of the engine.
- Change oil as stated in the engine manual.

SECTION 11: TROUBLE SHOOTING GUIDE

Trouble	Possible Cause(s)	Corrective Action
Engine fails to start	Blade control handle disengaged. Start control button not depressed. Spark plug wire disconnected. Safety key not in run position. Fuel tank empty, or stale fuel. Blocked fuel line. Faulty spark plug. Engine flooded. Engine not primed. Self starter already de-energized.	Engage blade control handle. Depress starter control button. Connect wire to spark plug. Place safety key in run position. Fill tank with clean, fresh gasoline. Clean fuel line. Clean, adjust gap or replace. Wait a few minutes. Push primer bulb three times to prime engine. Use recoil starter to start engine
Engine runs erratic	Spark plug wire loose. Blocked fuel line or stale fuel. Vent in gas cap plugged. Water or dirt in fuel system. Dirty air cleaner. Carburetor out of adjustment.	Connect and tighten spark plug wire. Clean fuel line; fill tank with clean, fresh gasoline. Clear vent. Drain fuel tank. Refill with fresh fuel. Clean air cleaner. Adjust carburetor.
Engine overheats	Engine oil level low. Air flow restricted. Carburetor not adjusted properly.	Fill crankcase with proper oil. Remove blower housing and clean. Adjust carburetor.
Occasional skip (hesitates) at high speed	Spark plug gap too close.	Adjust gap to .030".
Idles poorly	Spark plug fouled, faulty or gap too wide. Carburetor improperly adjusted. Dirty air cleaner.	Reset gap to .030" or replace spark plug. Adjust carburetor. Clean air cleaner.
Excessive vibration	Cutting blade loose or unbalanced. Bent cutting blade.	Tighten blade and adapter. Balance blade. Replace blade.
Mower will not mulch grass	Wet grass. Excessively high grass. Dull blade.	Do not mow when grass is wet; wait until later to cut. Mow once at a high cutting height, then mow again at desired height or make a narrower cutting swath (1/2 width). Sharpen or replace blade.
Uneven cut	Wheels not positioned correctly. Dull blade.	Place all four wheels in same height position. Sharpen or replace blade.

Refer to separate engine manual packed with your mower for more engine related information.

NOTE: For repairs beyond the minor adjustments listed above, contact your nearest authorized service dealer.

NOTES

SECTION 12: PARTS LIST FOR MODEL SERIES 440

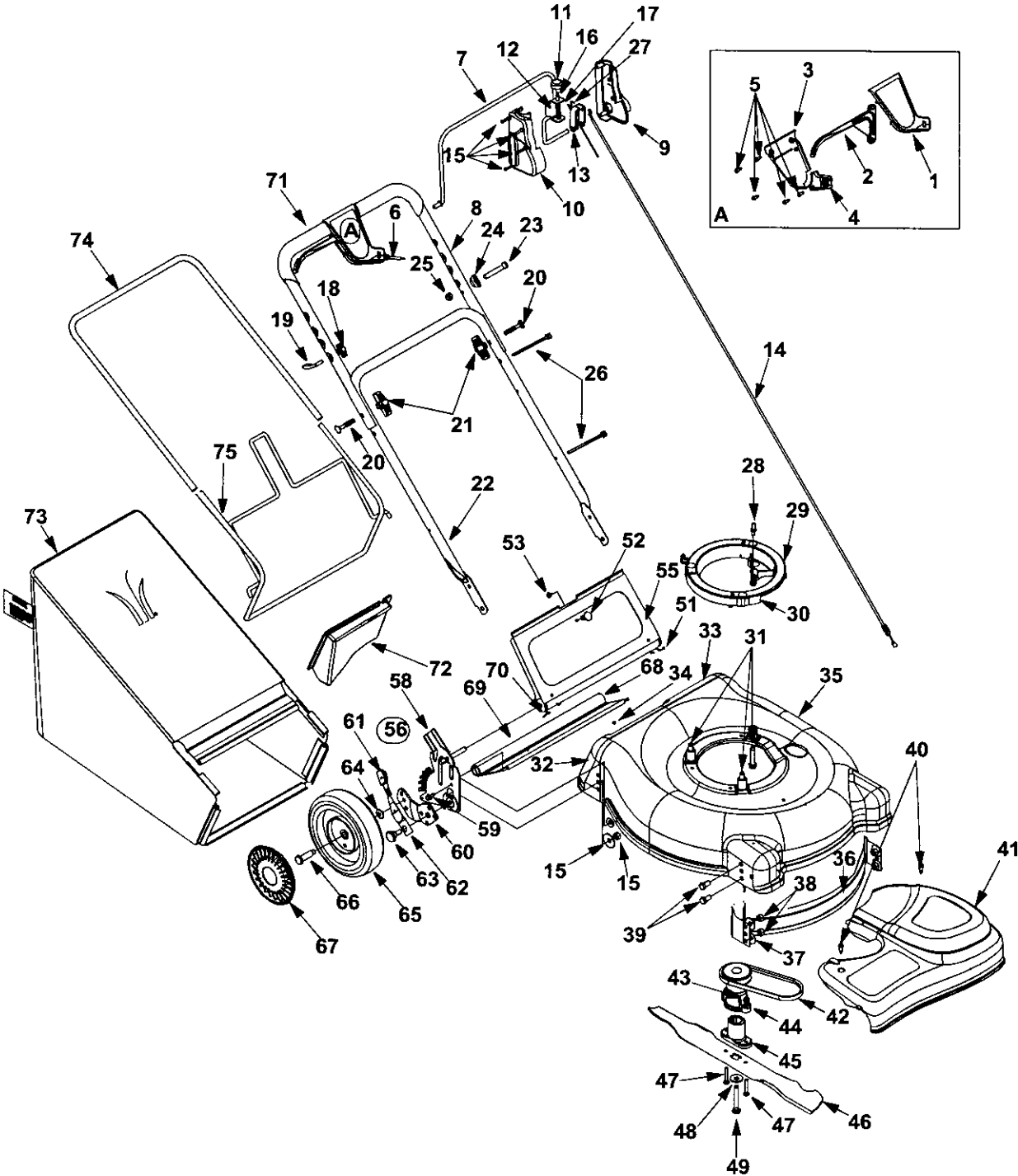

Model Series 440

Ref. No	Part No.	Description	Ref. No	Part No.	Description
1	731-1057	Upper Drive Cover	41	731-1937A	Front Drive Cover - Yellow
2	731-0620	Drive Lever	42	754-0465	V-Belt
3	731-1058	Lower Drive Cover	43	712-0324	Hex Lock Nut 1/4-20
4	731-1059	Mounting Cap	44	756-1146A	Drive Pulley
5	710-1667A	Screw #10-12:75	45	748-0411	Blade Adapter
6	746-0960	Drive Cable	46	742-0741	21" Mulching Blade w/star
7	647-0058	Control Bail Lever	47	736-0452	Bell Washer .396 I.D. x 1.140 O.D. x
8	749-1405	Upper Handle	48	710-0606	Hex Screw 1/4-20 x 1.50
9	731-2532	Control Cover LH	49	710-1257	Hex Screw 3/8-24 x 2.50
10	731-2533	Control Cover RH	50	712-3005	Hex Nut 3/8-16
11	720-0428	Button	51	732-0677	Torsion Spring L.H.
12	732-1171	Compression Spring	52	710-0192	Scr. Tr. Mach #10-24 x .380
13	782-0156	Lever	53	720-0275	Knob
14	746-1141	Control Cable 58.25" Lg.	54	714-0104	Cotter Pin
15	710-1256	Hi-Low Screw	55	782-7000	Rear Discharge Door
16	715-0168	Pin	56	682-0515A	Complete Handle Brkt Ass'y - LH
17	716-0209	Retention Ring		682-0516A	Complete Handle Brkt Ass'y - RH
18	720-0279	Knob	58	682-0511A	Handle Brkt Ass'y - LH
19	710-1205	Eye Bolt 1/4-20		682-0512A	Handle Brkt Ass'y - RH
20	710-1174	Carriage Bolt 5/16-18 x 2.0	59	710-0896	Hex Screw w/wsh. 1/4-14 x .62
21	720-0314	Knob	60	14766	Pivot Bar - LH
22	749-0928	Lower Handle		14765	Pivot Bar - RH
23	710-0501	Hex Hd. Cap Screw	61	720-0190	Knob
24	736-0451	Saddle Washer	62	732-0417A	Spring Lever
25	710-0324	Hex Lock Nut 1/4-20	63	738-0507B	Shldr Screw .500 Dia x .434 Long
26	726-0240	Cable Tie	64	736-0105	Bell Washer .380 x .880 x .062
27	732-1172	Torsion Spring	65	734-1979	Whl. Comp. 8 x 2 Pl. (Rear)
28	711-1293	Pin-Belt Keeper		734-1983	Wh. Comp. 8 x 2 Fwd. (Front)
29	631-0075B	Engine Spacer	66	738-0102	Shldr Screw .498 x 1.445
30	712-0271	Hex Nut 1/4-20 Thread	67	731-1426	Hubcap: Radial Spoke Yellow
31	710-1008	Tapp Screw w/Hex Lock Wash	68	732-0700	Wire
32	782-5004	Rear Baffle Right	69	731-1236	Rear Flap
33	782-5003	Rear Baffle Left	70	732-0678	Torsion Spring R.H.
34	710-1017	Scr. AB: 1/4-14 .625 Trust	71	720-0294	Foam Grip (2 required)
35	782-0080A	Deck 21" RD	72	782-5007A	Mulching Plug Baffle
36	782-5002	Front Baffle	73	764-0457A	Soft Top Grass Bag
37	712-0798	Bell Washer .39 x 1.13 x .062	74	764-0310	Grass Catcher Frame (Rear)
38	736-0331	Hex Nut 3/8-16	75	764-0311	Grass Catcher Frame (Front)
39	710-0216	Hex Screw 3/8-16 x .75	-	737-0208	Bottle of Oil (not shown)
40	7510042824	Screw #12 x .457			

Model Series 440

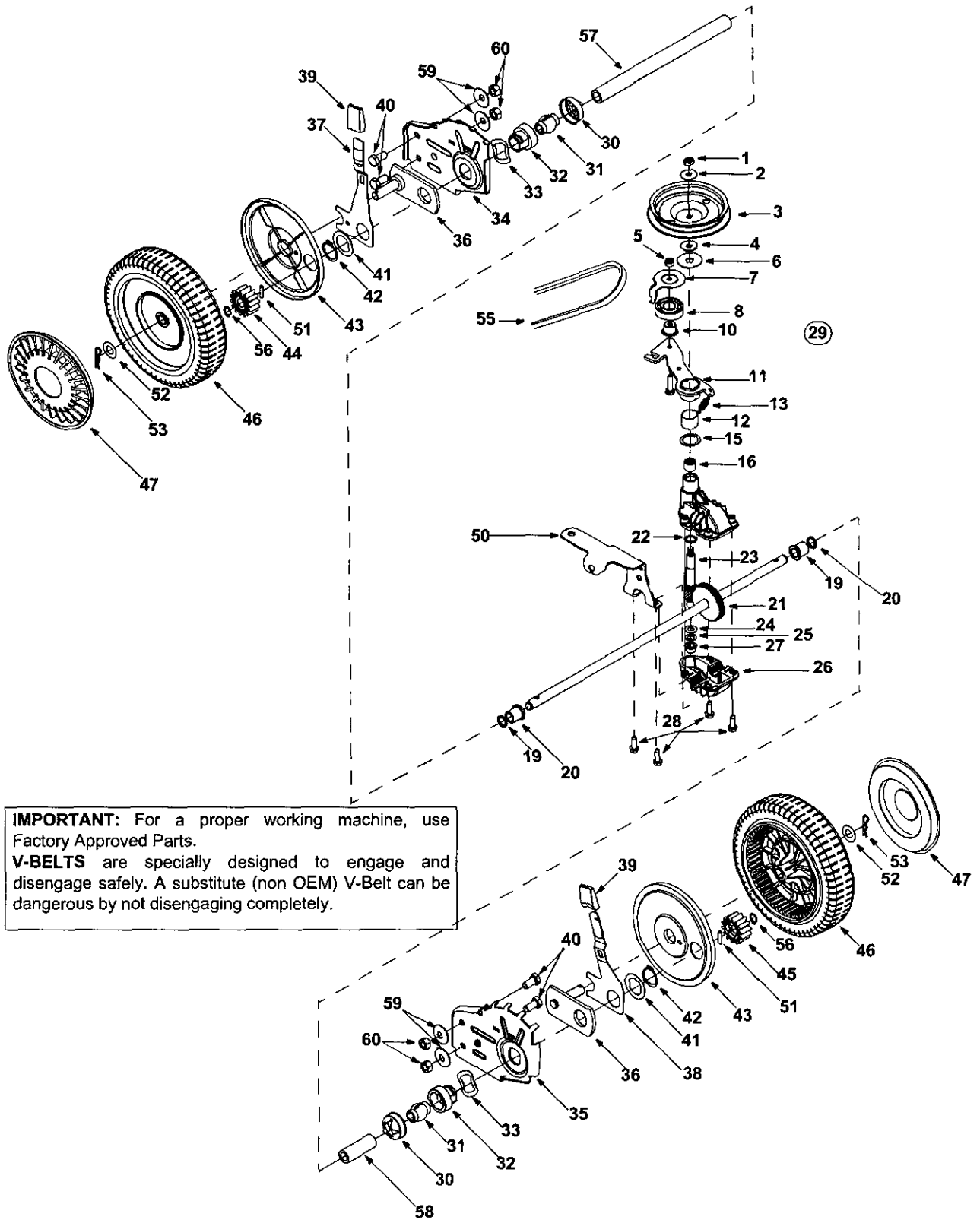

Model Series 440

Ref. No	Part No.	Description	Ref. No	Part No.	Description
1.	712-3025	Hex Jam Nut 5/16-24	31.	741-0604	Bearing Sleeve .50 I.D.
2.	736-0425	Bell Washer .325 x .930 x .045	32.	748-0355	Bearing Support
3.	756-1042	Pulley, 3.82 x .313 x .68	33.	736-0447	Wave Washer 1.5 x 1.0 x .029
4.	736-0425	Bell Washer .325 x .930 x .045	34.	782-0512B	RH Height Adj. Plate
5.	712-0896	Lock Nut 1/4-28	35.	782-0511A	LH Height Adj. Plate
6.	736-0406	Flat Washer .442 x 1.38 x .060	36.	682-0509	Pivot Plate Assembly
7.	782-7598	Belt Keeper	37.	732-0706	RH Front Lever
8.	741-0124	Ball Bearing	38.	732-0707	LH Front Lever
9.	721-0457	Oil Seal	39.	720-0190	Knob
10.	750-1050	Flange Spacer	40.	710-0216	Hex Cap Screw 3/8-16 x .75
11.	682-0028	Idler Bracket Assembly	41.	736-0474	Washer DD 1.5" O.D.
12.	741-0682A	Bearing Sleeve	42.	716-0102	Snap Ring 1.0 dia.
13.	732-0849A	Flat Washer .504 x .700 x .030	43.	782-7551	Wheel Dust Cap
14.	710-0299	Hex Cap Screw 1/4-28 x 1.00	44.	717-1762	Gear 14T R.H.
15.	736-0570	Flat Washer .865 x 1.145 x .030	45.	717-1761	Gear 14T L.H.
16.	741-0699	Needle Bearing .438 x .625 x .500	46.	634-0021A	Wheel, 8x2 x 1.75
17.	721-0325	Plug 1/4 x .437	47.	731-1426	Hubcap: Yellow
18.	618-0300A	Upper Housing	48.	682-0512A	RH Height Adj. Complete
19.	721-0329	Oil Seal .500 x .687 x .094	49.	682-0511A	LH Height Adj. Complete
20.	741-0673	Flange Bearing	50.	682-0030	Cable Idler Bracket
21.	611-0105A	Output Shaft	51.	715-0221	Dowel Pin
22.	736-0520	Flat Washer .504 x .700 x .030	52.	736-3013	Flat Washer 1/2 x 1.00 x .063
23.	717-1492	Pinion Shaft 10T	53.	714-0101	Cotter Pin .08 x 1.42
24.	736-0314	Thrust Washer .375 x .70 x .030	54.	738-1002	Screw
25.	736-0569	Thrust Washer .388 x .625 x .062	55.	754-0465	Belt
26.	618-0299A	Lower Housing	56.	716-0865	Snap Ring
27.	741-0672	Flange Bearing .378 x .531 x .370	57.	750-1165	Slev. Spacer
28.	710-1276	Hex Screw w/Washer 1/4-20 x .750	58.	750-1166	Slev. Spacer
29.	618-0606	Transmission Assembly Comp. (Includes Ref. # 1to Ref. #30)	59.	736-0331	Bell Washer
30.	732-0708	Bearing Retainer	60.	712-0798	Hex Nut 3/8-16

MANUFACTURER'S LIMITED WARRANTY FOR:



The limited warranty set forth below is given by MTD PRODUCTS INC ("MTD") with respect to new merchandise purchased and used in the United States, its possessions and territories.

MTD warrants this product against defects in material and workmanship for a period of two (2) years commencing on the date of original purchase and will, at its option, repair or replace, free of charge, any part found to be defective in material or workmanship. This limited warranty shall only apply if this product has been operated and maintained in accordance with the Operator's Manual furnished with the product, and has not been subject to misuse, abuse, commercial use, neglect, accident, improper maintenance, alteration, vandalism, theft, fire, water or damage because of other peril or natural disaster. Damage resulting from the installation or use of any accessory or attachment not approved by MTD Products Inc. for use with the product(s) covered by this manual will void your warranty as to any resulting damages.

Normal wear parts or components thereof are subject to separate terms as follows: All normal wear part or component failures will be covered on the product for a period of 90 days regardless of cause. After 90 days, but within the two year period, normal wear part failures will be covered ONLY IF caused by defects in material or workmanship of OTHER component parts. Normal wear parts and components include, but are not limited to, belts, blades, blade adapters, grass bags, rider deck wheels, seats, snow thrower skid shoes, shave plates and tires. Batteries are covered by a 90-day limited replacement warranty.

HOW TO OBTAIN SERVICE: Warranty service is available, WITH PROOF OF PURCHASE THROUGH YOUR LOCAL AUTHORIZED SERVICE DEALER. To locate the dealer in your area, please check for a listing in the Yellow Pages or contact the Customer Service Department of MTD PRODUCTS INC by calling 1-800-800-7310 or writing to P.O. Box 368022, Cleveland, Ohio 44136-9722.

This limited warranty does not provide coverage in the following cases:

- a. The engine or component parts thereof. These items carry a separate manufacturer's warranty. Please refer to the applicable manufacturer's warranty on these items.
- b. Log splitter pumps, valves and cylinders have a separate one year warranty.

- c. Routine maintenance items such as lubricants, filters, blade sharpening and tune-ups, or adjustments such as brake adjustments, clutch adjustments or deck adjustments; and normal deterioration of the exterior finish due to use or exposure.

- d. MTD does not extend any warranty for products sold or exported outside of the United States of America, its possessions and territories, except those sold through MTD's authorized channels of export distribution.

No implied warranty, including any implied warranty of merchantability or fitness for a particular purpose, applies after the applicable period of express written warranty above as to the parts as identified. No other express warranty or guaranty, whether written or oral, except as mentioned above, given by any person or entity, including a dealer or retailer, with respect to any product shall bind MTD. During the period of the Warranty, the exclusive remedy is repair or replacement of the product as set forth above. (Some states do not allow limitations on how long an implied warranty lasts, so the above limitation may not apply to you.)

The provisions as set forth in this Warranty provide the sole and exclusive remedy arising from the sales. MTD shall not be liable for incidental or consequential loss or damages including, without limitation, expenses incurred for substitute or replacement lawn care services, for transportation or for related expenses, or for rental expenses to temporarily replace a warranted product. (Some states do not allow the exclusion or limitation of incidental or consequential damages, so the above exclusion or limitation may not apply to you.)

In no event shall recovery of any kind be greater than the amount of the purchase price of the product sold. Alteration of the safety features of the product shall void this Warranty. You assume the risk and liability for loss, damage, or injury to you and your property and/or to others and their property arising out of the use or misuse or inability to use the product.

This limited warranty shall not extend to anyone other than the original purchaser, original lessee or the person for whom it was purchased as a gift.

How State Law Relates to this Warranty: This limited warranty gives you specific legal rights, and you may also have other rights which vary from state to state.