

Owner's Manual



LAWN TRACTOR

15.5 HP, 42" Mower

Electric Start

6 Speed Transaxle

Model No.

917.271552

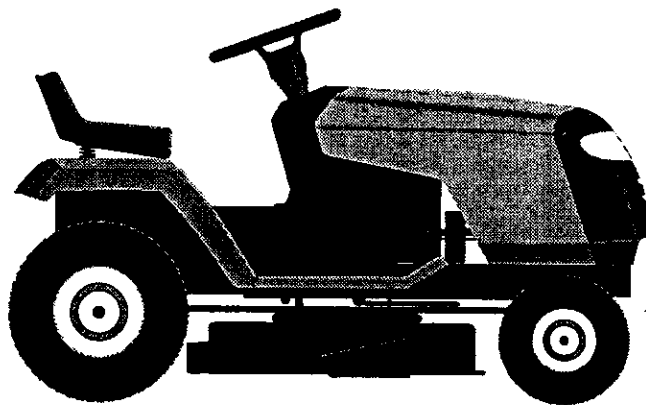

This product has a low emission engine which operates differently from previously built engines. Before you start the engine, read and understand this Owner's Manual.

CAUTION:

Read and follow all Safety Rules and Instructions before operating this equipment.

For answers to your questions about this product, Call:

1-800-659-5917

Sears Craftsman Help Line
5 am - 5 pm, Mon - Sat

Sears, Roebuck and Co., Hoffman Estates, IL 60179 U.S.A.
Visit our Craftsman website: www.sears.com/craftsman

TABLE OF CONTENTS

Warranty	2	Maintenance	17
Safety Rules	3	Service and Adjustments	21
Product Specifications	6	Storage	27
Assembly/Pre-Operation	8	Troubleshooting	28
Operation	11	Repair Parts	32
Maintenance Schedule	17	Sears Service	Back Cover

WARRANTY

LIMITED WARRANTY ON CRAFTSMAN RIDING EQUIPMENT

For two (2) years from the date of purchase, if this Craftsman Riding Equipment is maintained, lubricated and tuned up according to the instructions in the owner's manual, Sears will repair or replace free of charge any parts that are found to be defective in material or workmanship according to the guidelines of coverage listed below. Sears will also provide free labor for these applicable warranted parts for the two full years. During the first 30 days of purchase, there will be no charges to service the product at your home for issues covered by this warranty. (See exclusions below). For your convenience, IN HOME warranty service will still be available after the first 30 days of purchase, but a trip charge will apply. This charge will be waived if the Craftsman product is dropped off at an authorized Sears location. For the nearest authorized Sears location, please call 1-800-4-MY-HOME®. This warranty applies only while this product is within the United States.

This Warranty does not cover:

- Expendable items which become worn during normal use, including but not limited to blades, spark plugs, air cleaners, belts, and oil filters.
- Standard Maintenance Servicing, oil changes, or tune-ups
- Tire replacement or repair caused by punctures from outside objects, such as nails, thorns, stumps, or glass.
- Repairs necessary because of operator abuse, including but not limited to, damage caused by towing objects beyond the capability of the riding equipment, impacting objects that bend the frame or crankshaft, or over-speeding the engine.
- Repairs necessary because of operator negligence, including but not limited to, electrical and mechanical damage caused by improper storage, failure to use the proper grade and amount of engine oil, failure to keep the deck clear of flammable debris, or failure to maintain the equipment according to the instructions contained in the owner's manual.
- Engine (fuel system) cleaning or repairs caused by fuel determined to be contaminated or oxidized (stale). In general, fuel should be used within 30 days of its purchase date.
- Normal deterioration and wear of the exterior finishes, or product label replacement.
- Riding equipment used for commercial or rental purposes.

LIMITED WARRANTY ON BATTERY

For ninety (90) days from date of purchase, if any battery included with this riding equipment proves defective in material or workmanship and our testing determines the battery will not hold a charge, Sears will replace the battery at no charge. During the first 30 days of purchase, there will be no charges to replace the battery at your HOME. After the first 30 days, for your convenience, IN-HOME warranty service will still be available but a trip charge will apply. This charge will be waived if the Craftsman product is dropped off at an authorized Sears location. For the nearest authorized Sears location, please call 1-800-4-MY-HOME®.

This battery warranty applies only while this product is within the United States.

This warranty gives you specific legal rights, and you may also have other rights, which vary, from state to state.

Sears, Roebuck and Co., Dept. 817WA, Hoffman Estates, IL 60179

SAFETY RULES

IMPORTANT: This cutting machine is capable of amputating hands and feet and throwing objects. Failure to observe the following safety instructions could result in serious injury or death.

 Look for this symbol to point out important safety precautions. It means **CAUTION!!! BECOME ALERT!!! YOUR SAFETY IS INVOLVED.**

 **CAUTION:** In order to prevent accidental starting when setting up, transporting, adjusting or making repairs, always disconnect spark plug wire and place wire where it cannot contact spark plug.

 **CAUTION:** Do not coast down a hill in neutral, you may lose control of the tractor.

 **CAUTION:** Tow only the attachments that are recommended by and comply with specifications of the manufacturer of your tractor. Use common sense when towing. Operate only at the lowest possible speed when on a slope. Too heavy of a load, while on a slope, is dangerous. Tires can lose traction with the ground and cause you to lose control of your tractor.

 **WARNING:** Engine exhaust, some of its constituents, and certain vehicle components contain or emit chemicals known to the State of California to cause cancer and birth defects or other reproductive harm.

 **WARNING:** Battery posts, terminals and related accessories contain lead and lead compounds, chemicals known to the State of California to cause cancer and birth defects or other reproductive harm. **Wash hands after handling.**

I. GENERAL OPERATION

- Read, understand, and follow all instructions in the manual and on the machine before starting.
- Only allow responsible adults, who are familiar with the instructions, to operate the machine.
- Clear the area of objects such as rocks, toys, wire, etc., which could be picked up and thrown by the blade.
- Be sure the area is clear of other people before mowing. Stop machine if anyone enters the area.
- Never carry passengers.

- Do not mow in reverse unless absolutely necessary. Always look down and behind before and while backing.
- Be aware of the mower discharge direction and do not point it at anyone. Do not operate the mower without either the entire grass catcher or the guard in place.
- Slow down before turning.
- Never leave a running machine unattended. Always turn off blades, set parking brake, stop engine, and remove keys before dismounting.
- Turn off blades when not mowing.
- Stop engine before removing grass catcher or unclogging chute.
- Mow only in daylight or good artificial light.
- Do not operate the machine while under the influence of alcohol or drugs.
- Watch for traffic when operating near or crossing roadways.
- Use extra care when loading or unloading the machine into a trailer or truck.
- Data indicates that operators, age 60 years and above, are involved in a large percentage of riding mower-related injuries. These operators should evaluate their ability to operate the riding mower safely enough to protect themselves and others from serious injury.
- Keep machine free of grass, leaves or other debris build-up which can touch hot exhaust / engine parts and burn. Do not allow the mower deck to plow leaves or other debris which can cause build-up to occur. Clean any oil or fuel spillage before operating or storing the machine. Allow machine to cool before storage.

II. SLOPE OPERATION

Slopes are a major factor related to loss-of-control and tipover accidents, which can result in severe injury or death. All slopes require extra caution. If you cannot back up the slope or if you feel uneasy on it, do not mow it.

SAFETY RULES

DO:

- Mow up and down slopes, not across.
- Remove obstacles such as rocks, tree limbs, etc.
- Watch for holes, ruts, or bumps. Uneven terrain could overturn the machine. *Tall grass can hide obstacles.*
- Use slow speed. Choose a low gear so that you will not have to stop or shift while on the slope.
- Follow the manufacturer's recommendations for wheel weights or counterweights to improve stability.
- Use extra care with grass catchers or other attachments. These can change the stability of the machine.
- Keep all movement on the slopes *slow* and *gradual*. Do not make sudden changes in speed or direction.
- Avoid starting or stopping on a slope. If tires lose traction, disengage the blades and proceed slowly *straight* down the slope.

DO NOT:

- *Do not* turn on slopes unless necessary, and then, turn slowly and gradually downhill, if possible.
- *Do not* mow near drop-offs, ditches, or embankments. The mower could suddenly turn over if a wheel is over the edge of a cliff or ditch, or if an edge caves in.
- *Do not* mow on wet grass. Reduced traction could cause sliding.
- *Do not* try to stabilize the machine by putting your foot on the ground.
- *Do not* use grass catcher on steep slopes.

III. CHILDREN

Tragic accidents can occur if the operator is not alert to the presence of children. Children are often attracted to the machine and the mowing activity. *Never* assume that children will remain where you last saw them.

- Keep children out of the mowing area and under the watchful care of another responsible adult.
- Be alert and turn machine off if children enter the area.
- Before and when backing, look behind and *down* for small children.

- Never carry children. They may fall off and be seriously injured or interfere with safe machine operation.
- Never allow children to operate the machine.
- Use extra care when approaching blind corners, shrubs, trees, or other objects that may obscure vision.

IV. SERVICE

- Use extra care in handling gasoline and other fuels. They are flammable and vapors are explosive.
 - Use only an approved container.
 - Never remove gas cap or add fuel with the engine running. Allow engine to cool before refueling. Do not smoke.
 - Never refuel the machine indoors.
 - Never store the machine or fuel container inside where there is an open flame, such as a water heater.
- Never run a machine inside a closed area.
- Keep nuts and bolts, especially blade attachment bolts, tight and keep equipment in good condition.
- Never tamper with safety devices. Check their proper operation regularly.
- Keep machine free of grass, leaves, or other debris build-up. Clean oil or fuel spillage. Allow machine to cool before storing.
- Stop and inspect the equipment if you strike an object. Repair, if necessary, before restarting.
- Never make adjustments or repairs with the engine running.
- Grass catcher components are subject to wear, damage, and deterioration, which could expose moving parts or allow objects to be thrown. Frequently check components and replace with manufacturer's recommended parts, when necessary.
- Mower blades are sharp and can cut. Wrap the blade(s) or wear gloves, and use extra caution when servicing them.
- Check brake operation frequently. Adjust and service as required.

SAFETY RULES



- Be sure the area is clear of other people before mowing. Stop machine if anyone enters the area.
- Never carry passengers or children even with the blades off.
- Do not mow in reverse unless absolutely necessary. Always look down and behind before and while backing.
- Never carry children. They may fall off and be seriously injured or interfere with safe machine operation.
- Keep children out of the mowing area and under the watchful care of another responsible adult.
- Be alert and turn machine off if children enter the area.
- Before and when backing, look behind and down for small children.
- Mow up and down slopes (15° Max), not across.
- Remove obstacles such as rocks, tree limbs, etc.
- Watch for holes, ruts, or bumps. Uneven terrain could overturn the machine. Tall grass can hide obstacles.
- Use slow speed. Choose a low gear so that you will not have to stop or shift while on the slope.
- Avoid starting or stopping on a slope. If tires lose traction, disengage the blades and proceed slowly straight down the slope.
- If machine stops while going uphill, disengage blades, shift into reverse and back down slowly.
- Do not turn on slopes unless necessary, and then, turn slowly and gradually downhill, if possible.

PRODUCT SPECIFICATIONS

Gasoline Capacity and Type:	1.25 Gallons Unleaded Regular
Oil Type: (API-SF-SJ):	SAE 30 (above 32°F) SAE 5W-30 (below 32°F)
Oil Capacity:	3.0 Pints
Spark Plug: (Gap: .030")	Champion RC12YC
Ground Speed (MPH):	Forward: 1st 1.1 2nd 1.4 3rd 2.2 4th 3.4 5th 4.3 6th 5.5 Reverse: 1.7
Tire Pressure:	Front: 14 PSI Rear: 12 PSI
Charging System:	3 Amps Battery 5 Amps Headlights
Battery:	Amp/Hr: 28 Min. CCA: 230 Case Size: U1R
Blade Bolt Torque:	27-35 Ft. Lbs.

CONGRATULATIONS on your purchase of a new tractor. It has been designed, engineered and manufactured to give you the best possible dependability and performance.

Should you experience any problem you cannot easily remedy, please contact a Sears or other qualified service center. We have competent, well-trained technicians and the proper tools to service or repair this tractor.

Please read and retain this manual. The instructions will enable you to assemble and maintain your tractor properly. Always observe the "SAFETY RULES".

REPAIR AGREEMENT

A Repair Agreement is available on this product. Contact your nearest Sears store for details.

CUSTOMER RESPONSIBILITIES

- Read and observe the safety rules.
- Follow a regular schedule in maintaining, caring for and using your tractor.
- Follow the instructions under "Maintenance" and "Storage" sections of this owner's manual.

WARNING: This tractor is equipped with an internal combustion engine and should not be used on or near any unimproved forest-covered, brush-covered or grass-covered land unless the engine's exhaust system is equipped with a spark arrester meeting applicable local or state laws (if any). If a spark arrester is used, it should be maintained in effective working order by the operator.

In the state of California the above is required by law (Section 4442 of the California Public Resources Code). Other states may have similar laws. Federal laws apply on federal lands. A spark arrester for the muffler is available through your nearest Sears service center (See REPAIR PARTS section of this manual).

UNASSEMBLED PARTS

Steering Wheel

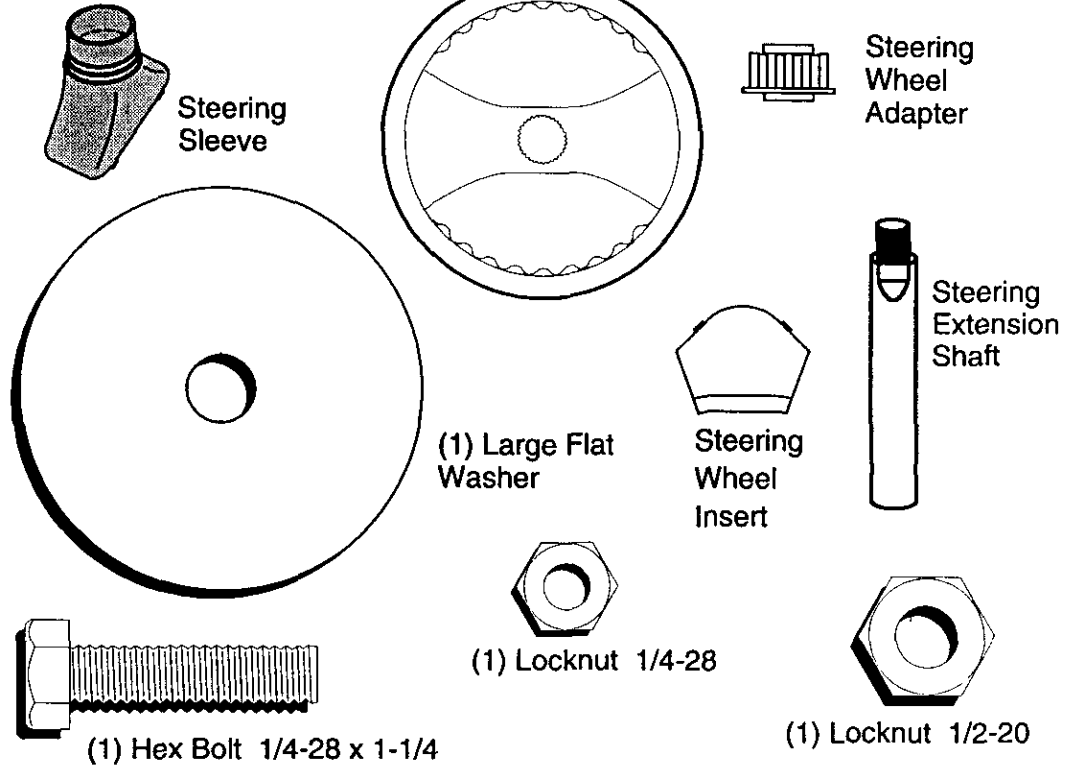

Seat

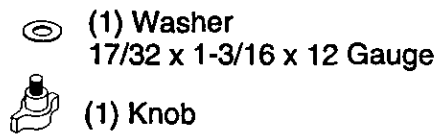
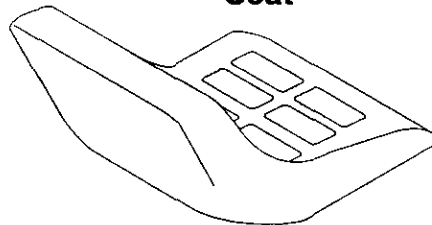

Keys

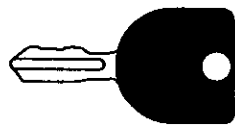

(2) Keys

Video Cassette

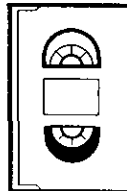

Slope Sheet

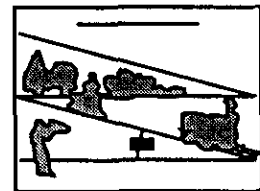

ASSEMBLY/PRE-OPERATION

Your new tractor has been assembled at the factory with the exception of those parts left unassembled for shipping purposes. To ensure safe and proper operation of your tractor all parts and hardware you assemble must be tightened securely. Use the correct tools as necessary to insure proper tightness. Review the video cassette before you begin.

TOOLS REQUIRED FOR ASSEMBLY

A socket wrench set will make assembly easier. Standard wrench sizes you need are listed below.

- (2) 7/16" wrench
- (1) Pliers
- (1) 3/4" wrench
- (1) Utility knife
- (1) Tire pressure gauge

When right or left hand is mentioned in this manual, it means, from your point of view, when you are in the operating position (seated behind the steering wheel).

TO REMOVE TRACTOR FROM CARTON

UNPACK CARTON

1. Remove all accessible loose parts and parts boxes from carton.
2. Cut, from top to bottom, along lines on all four corners of carton, and lay panels flat.
3. Check for any additional loose parts or cartons and remove.

BEFORE REMOVING TRACTOR FROM SKID

ATTACH STEERING WHEEL

ASSEMBLE EXTENSION SHAFT AND BOOT

1. Slide extension shaft onto lower steering shaft. Align mounting holes in extension and lower shafts and install 1/4 hex bolt and locknut. Tighten securely.

IMPORTANT: Tighten bolt and nut securely to 10-12 ft. lbs torque.

2. Place tabs of steering boot over tab slots in dash and push down to secure.

INSTALL STEERING WHEEL

3. Position front wheels of the tractor so they are pointing straight forward.
4. Remove steering wheel adapter from steering wheel and slide adapter onto steering shaft extension.
5. Position steering wheel so cross bars are horizontal (left to right) and slide inside boot and onto adapter.

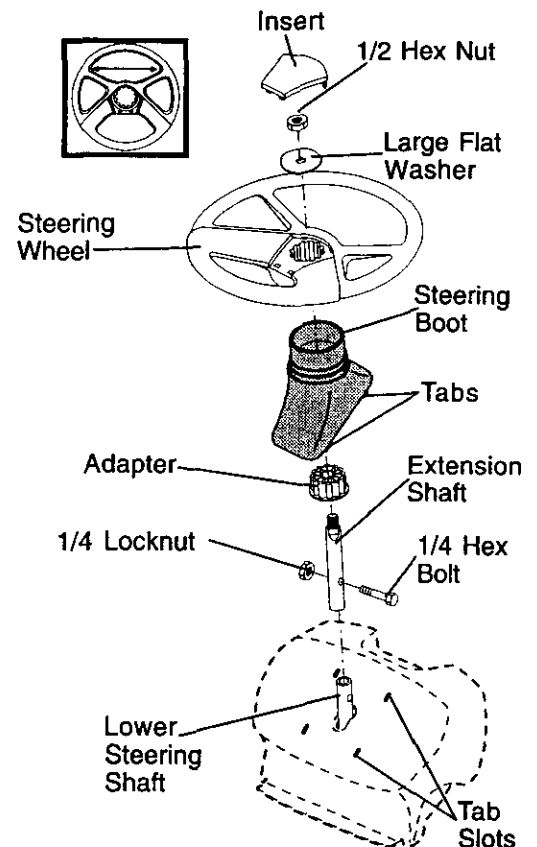

6. Assemble large flat washer, 1/2 hex nut and tighten securely.
7. Snap steering wheel insert into center of steering wheel.
8. Remove protective materials from tractor hood and grill.

IMPORTANT: Check for and remove any staples in skid that may puncture tires where tractor is to roll off skid.

CHECK BATTERY

1. Lift seat pan to raised position.
- NOTE:** If this battery is put into service after month and year indicated on label (label located between terminals) charge battery for minimum of one hour at 6-10 amps. (See "BATTERY" in Maintenance section of this manual for charging instructions).

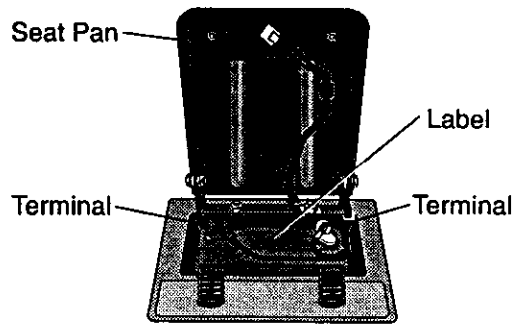

INSTALL SEAT

Adjust seat before tightening adjustment knob.

1. Remove adjustment knob and flat washer securing seat to cardboard packing and set aside for assembly of seat to tractor.
2. Pivot seat upward and remove from the cardboard packing. Remove the cardboard packing and discard.
3. Place seat on seat pan so head of shoulder bolt is positioned over large slotted hole in pan.
4. Push down on seat to engage shoulder bolt in slot and pull seat towards rear of tractor.
5. Pivot seat and pan forward and assemble adjustment knob and flat washer loosely. Do not tighten.
6. Lower seat into operating position and sit in seat.
7. Slide seat until a comfortable position is reached which allows you to press clutch/brake pedal all the way down.
8. Get off seat without moving its adjusted position.
9. Raise seat and tighten adjustment knob securely.

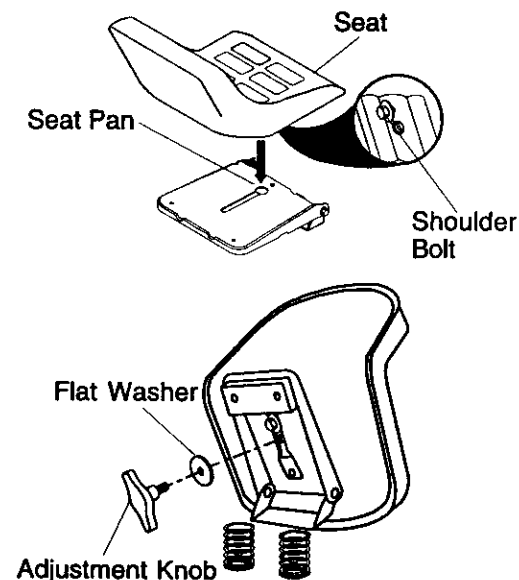

NOTE: You may now roll or drive your tractor off the skid. Follow the appropriate instruction below to remove the tractor from the skid.

TO ROLL TRACTOR OFF SKID (See Operation section for location and function of controls)

1. Press lift lever plunger and raise attachment lift lever to its highest position.
2. Release parking brake by depressing clutch/brake pedal.
3. Place gearshift lever in neutral (N) position.
4. Roll tractor forward off skid.
5. Remove banding holding deflector shield up against tractor.

TO DRIVE TRACTOR OFF SKID (See Operation section for location and function of controls)

WARNING: Before starting, read, understand and follow all instructions in the Operation section of this manual. Be sure tractor is in a well-ventilated area. Be sure the area in front of tractor is clear of other people and objects.

1. Be sure all the above assembly steps have been completed.
2. Check engine oil level and fill fuel tank with gasoline.
3. Sit on seat in operating position, depress clutch/brake pedal and set the parking brake.
4. Place gear shift lever in neutral (N) position.
5. Press lift lever plunger and raise attachment lift lever to its highest position.
6. Start the engine. After engine has started, move throttle control to idle position.
7. Depress clutch/brake pedal into full "BRAKE" position and hold. Move gearshift lever to 1st gear.
8. Slowly release clutch/brake pedal and slowly drive tractor off skid.
9. Apply brake to stop tractor, set parking brake and place gearshift lever in neutral position.
10. Turn ignition key to "STOP" position. Continue with the instructions that follow.

CHECK TIRE PRESSURE

The tires on your tractor were overinflated at the factory for shipping purposes. Correct tire pressure is important for best cutting performance.

- Reduce tire pressure to PSI shown in "PRODUCT SPECIFICATIONS" section of this manual.

CHECK DECK LEVELNESS

For best cutting results, mower housing should be properly leveled. See "TO LEVEL MOWER HOUSING" in the Service and Adjustments section of this manual.

CHECK FOR PROPER POSITION OF ALL BELTS

See the figures that are shown for replacing motion and mower blade drive belts in the Service and Adjustments section of this manual. Verify that the belts are routed correctly.

CHECK BRAKE SYSTEM

After you learn how to operate your tractor, check to see that the brake is properly adjusted. See "TO ADJUST BRAKE" in the Service and Adjustments section of this manual.

✓CHECKLIST

Before you operate your new tractor, we wish to assure that you receive the best performance and satisfaction from this Quality Product.

Please review the following checklist:

- ✓ All assembly instructions have been completed.
- ✓ No remaining loose parts in carton.
- ✓ Battery is properly prepared and charged. (Minimum 1 hour at 6 amps).
- ✓ Seat is adjusted comfortably and tightened securely.
- ✓ All tires are properly inflated. (For shipping purposes, the tires were overinflated at the factory).
- ✓ Be sure mower deck is properly leveled side-to-side/front-to-rear for best cutting results. (Tires must be properly inflated for leveling).
- ✓ Check mower and drive belts. Be sure they are routed properly around pulleys and inside all belt keepers.
- ✓ Check wiring. See that all connections are still secure and wires are properly clamped.

While learning how to use your tractor, pay extra attention to the following important items:

- ✓ Engine oil is at proper level.
- ✓ Fuel tank is filled with fresh, clean, regular unleaded gasoline.
- ✓ Become familiar with all controls - their location and function. Operate them before you start the engine.
- ✓ Be sure brake system is in safe operating condition.

OPERATION

These symbols may appear on your tractor or in literature supplied with the product. Learn and understand their meaning.



BATTERY



CAUTION OR WARNING



REVERSE



FORWARD



FAST



SLOW



ENGINE ON



ENGINE OFF



OIL PRESSURE

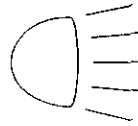

LIGHTS ON



OVER TEMP LIGHT



MOWER LIFT



FUEL



CHOKE



MOWER HEIGHT



PARKING BRAKE LOCKED



UNLOCKED



ATTACHMENT CLUTCH ENGAGED



REVERSE



NEUTRAL



HIGH



LOW



PARKING BRAKE



IGNITION



ATTACHMENT CLUTCH DISENGAGED



KEEP AREA CLEAR



SLOPE HAZARDS



(SEE SAFETY RULES SECTION)



DANGER, KEEP HANDS AND FEET AWAY

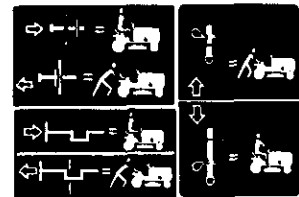

FREE WHEEL
(Automatic Models only)

KNOW YOUR TRACTOR

READ THIS OWNER'S MANUAL AND SAFETY RULES BEFORE OPERATING YOUR TRACTOR

Compare the illustrations with your tractor to familiarize yourself with the locations of various controls and adjustments. Save this manual for future reference.

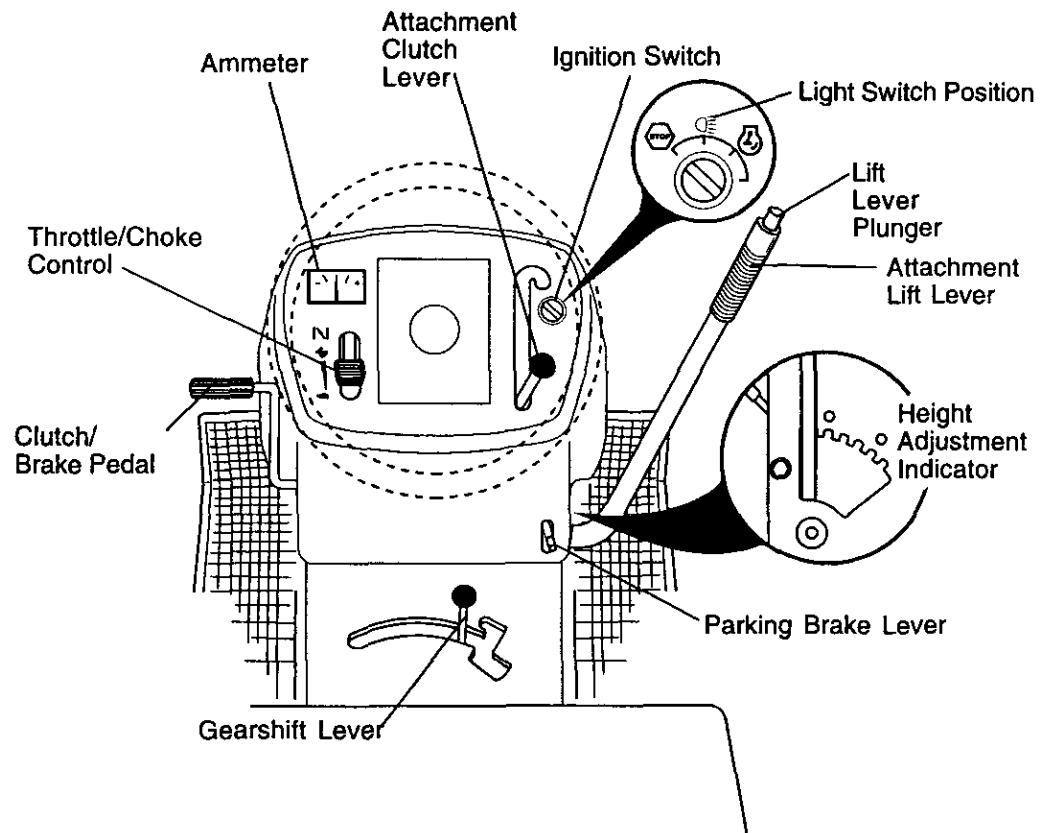

Our tractors conform to the safety standards of the American National Standards Institute.

ATTACHMENT CLUTCH LEVER - Used to engage the mower blades, or other attachments mounted to your tractor.

ATTACHMENT LIFT LEVER - Used to raise, lower, and adjust the mower deck or other attachments mounted to your tractor.

CLUTCH/BRAKE PEDAL - Used for declutching and braking the tractor and starting the engine.

GEARSHIFT LEVER - Selects the speed and direction of tractor.

IGNITION SWITCH - Used for starting and stopping the engine.

LIFT LEVER PLUNGER - Used to release attachment lift lever when changing its position.

LIGHT SWITCH POSITION - Turns the headlights on and off.

PARKING BRAKE LEVER - Locks clutch/ brake pedal into the brake position.

THROTTLE/CHOKE CONTROL - Used for starting and controlling engine speed.

AMMETER - Indicates battery charging (+) or discharging (-).



The operation of any tractor can result in foreign objects thrown into the eyes, which can result in severe eye damage. Always wear safety glasses or eye shields while operating your tractor or performing any adjustments or repairs. We recommend standard safety glasses or a wide vision safety mask worn over spectacles.

HOW TO USE YOUR TRACTOR TO SET PARKING BRAKE

Your tractor is equipped with an operator presence sensing switch. When engine is running, any attempt by the operator to leave the seat without first setting the parking brake will shut off the engine.

1. Depress clutch/brake pedal all the way down and hold.
2. Pull parking brake lever up and release pressure from clutch/brake pedal. Pedal should remain in brake position. Make sure parking brake will hold tractor secure.

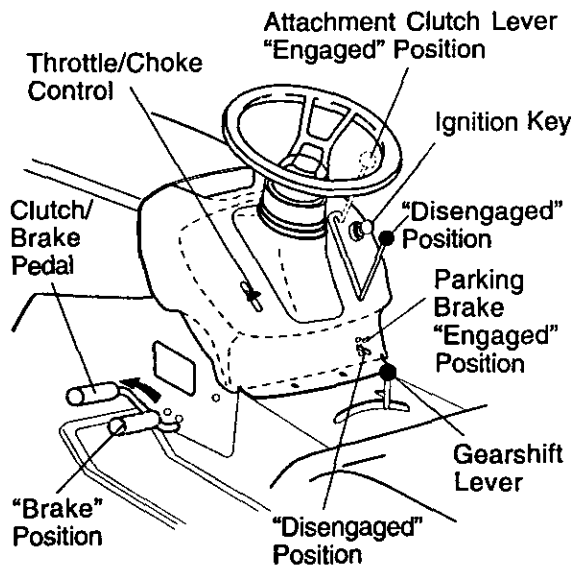

STOPPING

MOWER BLADES -

- To stop mower blades, move attachment clutch lever to disengaged position.

GROUND DRIVE -

- To stop ground drive, depress clutch/brake pedal all the way down.
- Move gearshift lever to neutral (N) position.

ENGINE -

- Move throttle control to slow position.
- NOTE:** Failure to move throttle control to slow position and allowing engine to idle before stopping may cause engine to "backfire".

- Turn ignition key to "STOP" position and remove key. Always remove key when leaving tractor to prevent unauthorized use.

- Never use choke to stop engine.

IMPORTANT: Leaving the ignition switch in any position other than "STOP" will cause the battery to discharge and go dead.

NOTE: Under certain conditions when tractor is standing idle with the engine running, hot engine exhaust gases may cause "browning" of grass. To eliminate this possibility, always stop engine when stopping tractor on grass areas.

CAUTION: Always stop tractor completely, as described above, before leaving the operator's position.

TO USE THROTTLE CONTROL

Always operate engine at full throttle.

- Operating engine at less than full throttle reduces the battery charging rate.
- Full throttle offers the best bagging and mower performance.

TO MOVE FORWARD AND BACKWARD

The direction and speed of movement is controlled by the gearshift lever.

1. Start tractor with clutch/brake pedal depressed and gearshift lever in neutral (N) position.
2. Move gearshift lever to desired position.
3. Slowly release clutch/brake pedal to start movement.

IMPORTANT: Bring tractor to a complete stop before shifting or changing gears. Failure to do so will shorten the useful life of your transaxle.

TO ADJUST MOWER CUTTING HEIGHT

The position of the attachment lift lever determines the cutting height.

- Grasp lift lever.
- Press plunger with thumb and move lever to desired position.

The cutting height range is approximately 1-1/2 to 4". The heights are measured from the ground to the blade tip with the engine not running.

These heights are approximate and may vary depending upon soil conditions, height of grass and types of grass being mowed.

- The average lawn should be cut to approximately 2-1/2 inches during the cool season and to over 3 inches during hot months. For healthier and better looking lawns, mow often and after moderate growth.
- For best cutting performance, grass over 6 inches in height should be mowed twice. Make the first cut relatively high; the second to desired height.

TO OPERATE MOWER

Your tractor is equipped with an operator presence sensing switch. Any attempt by the operator to leave the seat with the engine running and the attachment clutch engaged will shut off the engine.

1. Select desired height of cut.
2. Start mower blades by engaging attachment clutch control.

To stop mower blades - disengage attachment clutch control.

CAUTION: Do not operate the mower without either the entire grass catcher, on mowers so equipped, or the deflector shield in place.

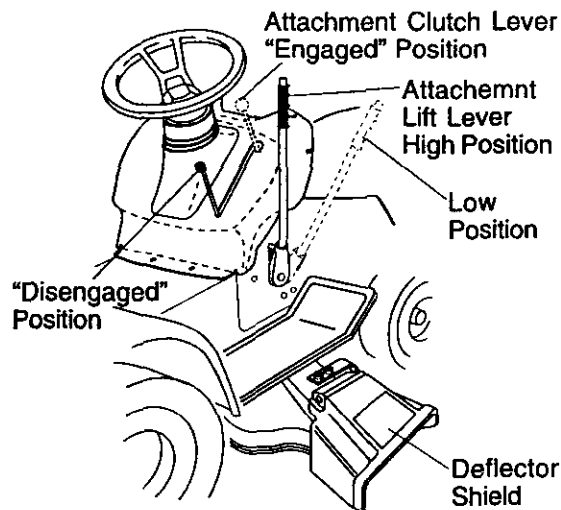

TO OPERATE ON HILLS

CAUTION: Do not drive up or down hills with slopes greater than 15° and do not drive across any slope. Use the slope guide at the back of this manual.

- Choose the slowest speed before starting up or down hills.
- Avoid stopping or changing speed on hills.

- If slowing is necessary, move throttle control lever to slower position.
- If stopping is absolutely necessary, push clutch/brake pedal quickly to brake position and engage parking brake.
- Move gearshift lever to 1st gear. Be sure you have allowed room for tractor to roll slightly as you restart movement.
- To restart movement, slowly release parking brake and clutch/brake pedal.
- Make all turns slowly.

TO TRANSPORT

- Raise attachment lift to highest position with attachment lift control.
- When pushing or towing your tractor, be sure gearshift lever is in neutral (N) position.
- Do not push or tow tractor at more than five (5) MPH.

NOTE: To protect hood from damage when transporting your tractor on a truck or a trailer, be sure hood is closed and secured to tractor. Use an appropriate means of tying hood to tractor (rope, cord, etc.).

TOWING CARTS AND OTHER ATTACHMENTS

Tow only the attachments that are recommended by and comply with specifications of the manufacturer of your tractor. Use common sense when towing. Too heavy of a load, while on a slope, is dangerous. Tires can lose traction with the ground and cause you to lose control of your tractor.

BEFORE STARTING THE ENGINE

CHECK ENGINE OIL LEVEL

The engine in your tractor has been shipped, from the factory, already filled with summer weight oil.

1. Check engine oil with tractor on level ground.
 2. Remove oil fill cap/dipstick and wipe clean, reinsert the dipstick and screw cap tight, wait for a few seconds, remove and read oil level. If necessary, add oil until "FULL" mark on dipstick is reached. Do not overfill.
- For cold weather operation you should change oil for easier starting (See "OIL VISCOSITY CHART" in the Maintenance section of this manual).
 - To change engine oil, see the Maintenance section in this manual.

ADD GASOLINE

- Fill fuel tank to bottom of tank filler neck. Do not overfill. Use fresh, clean, regular unleaded gasoline with a minimum of 87 octane. (Use of leaded gasoline will increase carbon and lead oxide deposits and reduce valve life). Do not mix oil with gasoline. Purchase fuel in quantities that can be used within 30 days to assure fuel freshness.

⚠ CAUTION: Wipe off any spilled oil or fuel. Do not store, spill or use gasoline near an open flame.

IMPORTANT: When operating in temperatures below 32°F(0°C), use fresh, clean winter grade gasoline to help insure good cold weather starting.

⚠ CAUTION: Alcohol blended fuels (called gasohol or using ethanol or methanol) can attract moisture which leads to separation and formation of acids during storage. Acidic gas can damage the fuel system of an engine while in storage. To avoid engine problems, the fuel system should be emptied before storage of 30 days or longer. Drain the gas tank, start the engine and let it run until the fuel lines and carburetor are empty. Use fresh fuel next season. See Storage Instructions for additional information. Never use engine or carburetor cleaner products in the fuel tank or permanent damage may occur.

TO START ENGINE

When starting the engine for the first time or if the engine has run out of fuel, it will take extra cranking time to move fuel from the tank to the engine.

1. Sit on seat in operating position, depress clutch/brake pedal and set parking brake.
2. Place gear shift lever in neutral (N) position.
3. Move attachment clutch to disengaged position.
4. Move throttle control to choke position.

NOTE: Before starting, read the warm and cold starting procedures below.

5. Insert key into ignition and turn key clockwise to start position and release key as soon as engine starts. Do not run starter continuously for more than fifteen seconds per minute. If the engine does not start after several attempts, move throttle control to fast position, wait a few minutes and try again. If engine still does not start, move the throttle control back to the choke position and retry.

WARM WEATHER STARTING (50° F and above)

6. When engine starts, move the throttle control to the fast position.
- The attachments and ground drive can now be used. If the engine does not accept the load, restart the engine and allow it to warm up for one minute using the choke as described above.

COLD WEATHER STARTING (50° F and below)

6. When engine starts, allow engine to run with the throttle control in the choke position until the engine runs roughly, then move throttle control to fast position. This may require an engine warm-up period from several seconds to several minutes, depending on the temperature.

- The attachments can also be used during the engine warm-up period.

NOTE: If at a high altitude (above 3000 feet) or in cold temperatures (below 32 F) the carburetor fuel mixture may need to be adjusted for best engine performance. (See "TO ADJUST CARBURETOR" in the Service and Adjustments section of this manual).

MOWING TIPS

- Mower should be properly leveled for best mowing performance. See "TO LEVEL MOWER HOUSING" in the Service and Adjustments section of this manual.
 - The left hand side of mower should be used for trimming.
 - Drive so that clippings are discharged onto the area that has already been cut. Have the cut area to the right of the tractor. This will result in a more even distribution of clippings and more uniform cutting.
 - When mowing large areas, start by turning to the right so that clippings will discharge away from shrubs, fences, driveways, etc. After one or two rounds, mow in the opposite direction making left hand turns until finished.
- If grass is extremely tall, it should be mowed twice to reduce load and possible fire hazard from dried clippings. Make first cut relatively high; the second to the desired height.
 - Do not mow grass when it is wet. Wet grass will plug mower and leave undesirable clumps. Allow grass to dry before mowing.
 - **Always operate engine at full throttle when mowing** to assure better mowing performance and proper discharge of material. Regulate ground speed by selecting a low enough gear to give the mower cutting performance as well as the quality of cut desired.
 - When operating attachments, select a ground speed that will suit the terrain and give best performance of the attachment being used.

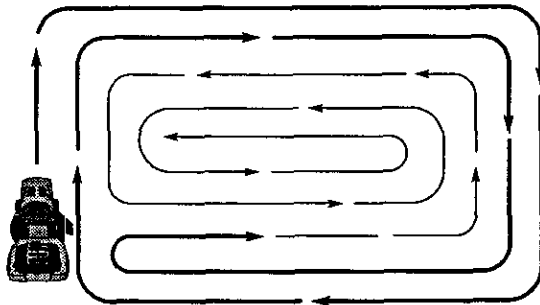

MAINTENANCE

MAINTENANCE SCHEDULE FILL IN DATES AS YOU COMPLETE REGULAR SERVICE		BEFORE EACH USE					BEFORE STORAGE						
		EVERY 8 HOURS	EVERY 25 HOURS	EVERY 50 HOURS	EVERY 100 HOURS	EVERY SEASON	EVERY 8 HOURS	EVERY 25 HOURS	EVERY 50 HOURS	EVERY 100 HOURS	EVERY SEASON		
TRACTOR	Check Brake Operation	✓	✓										
	Check Tire Pressure	✓	✓										
	Check Operator Presence and Interlock Systems	✓											
	Check for Loose Fasteners	✓				✓ ⁵	✓						
	Sharpen/Replace Mower Blades			✓ ³									
	Lubrication Chart			✓				✓					
	Check Battery Level			✓									
	Clean Battery and Terminals			✓							✓		
	Check Transaxle Cooling			✓									
	Check V-Belts					✓							
ENGINE	Check Engine Oil Level	✓	✓										
	Change Engine Oil (with oil filter)				✓ ^{1,2}					✓			
	Change Engine Oil (without oil filter)			✓ ^{1,2}						✓			
	Clean Air Filter			✓ ²									
	Clean Air Screen			✓ ²									
	Inspect Muffler/Spark Arrester				✓								
	Replace Oil Filter (If equipped)						✓ ^{1,2}						
	Clean Engine Cooling Fins						✓ ²						
	Replace Spark Plug						✓		✓				
	Replace Air Filter Paper Cartridge						✓ ²						
Replace Fuel Filter												✓	

1 - Change more often when operating under a heavy load or in high ambient temperatures.
 2 - Service more often when operating in dirty or dusty conditions.

3 - Replace blades more often when mowing in sandy soil.
 4 - Not required if equipped with maintenance-free battery.
 5 - Tighten front axle pivot bolt to 35 ft.-lbs. maximum. Do not overtighten.

GENERAL RECOMMENDATIONS

The warranty on this tractor does not cover items that have been subjected to operator abuse or negligence. To receive full value from the warranty, operator must maintain tractor as instructed in this manual.

Some adjustments will need to be made periodically to properly maintain your tractor.

All adjustments in the Service and Adjustments section of this manual should be checked at least once each season.

- Once a year you should replace the spark plug, clean or replace air filter, and check blades and belts for wear. A new spark plug and clean air filter assure proper air-fuel mixture and help your engine run better and last longer.

BEFORE EACH USE

- Check engine oil level.
- Check brake operation.
- Check tire pressure.
- Check operator presence and interlock systems for proper operation.
- Check for loose fasteners.

LUBRICATION CHART

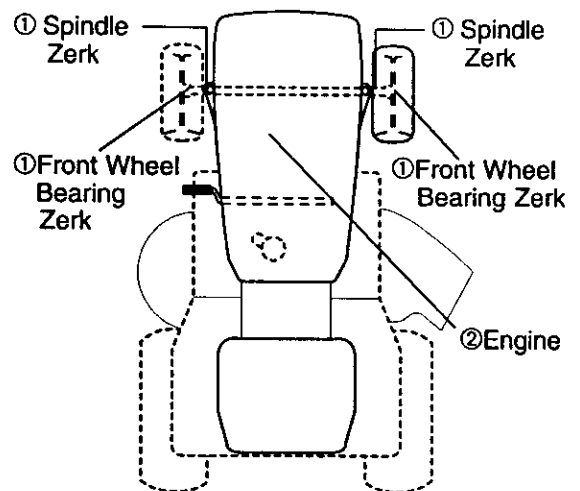

- ① General Purpose Grease
- ② Refer to Maintenance "ENGINE" Section

IMPORTANT: Do not oil or grease the pivot points which have special nylon bearings. Viscous lubricants will attract dust and dirt that will shorten the life of the self-lubricating bearings. If you feel they must be lubricated, use only a dry, powdered graphite type lubricant sparingly.

TRACTOR

Always observe safety rules when performing any maintenance.

BRAKE OPERATION

If tractor requires more than six (6) feet stopping distance at high speed in highest gear, then brake must be adjusted. (See "TO ADJUST BRAKE" in the Service and Adjustments section of this manual).

TIRES

- Maintain proper air pressure in all tires (See "PRODUCT SPECIFICATIONS" section of this manual).
- Keep tires free of gasoline, oil, or insect control chemicals which can harm rubber.
- Avoid stumps, stones, deep ruts, sharp objects and other hazards that may cause tire damage.

NOTE: To seal tire punctures and prevent flat tires due to slow leaks, tire sealant may be purchased from your local parts dealer. Tire sealant also prevents tire dry rot and corrosion.

OPERATOR PRESENCE SYSTEM

Be sure operator presence and interlock systems are working properly. If your tractor does not function as described, repair the problem immediately.

- The engine should not start unless the clutch/brake pedal is fully depressed and attachment clutch control is in the disengaged position.
- When the engine is running, any attempt by the operator to leave the seat without first setting the parking brake should shut off the engine.
- When the engine is running and the attachment clutch is engaged, any attempt by the operator to leave the seat should shut off the engine.
- The attachment clutch should never operate unless the operator is in the seat.

BLADE CARE

For best results mower blades must be kept sharp. Replace bent or damaged blades.

BLADE REMOVAL

1. Raise mower to highest position to allow access to blades.
2. Remove hex bolt, lock washer and flat washer securing blade.
3. Install new or resharpened blade with trailing edge up towards deck as shown.

IMPORTANT: To ensure proper assembly, center hole in blade must align with star on mandrel assembly.

4. Reassemble hex bolt, lock washer and flat washer in exact order as shown.
5. Tighten bolt securely (27-35 Ft. Lbs. torque).

IMPORTANT: Blade bolt is grade 8 heat treated.

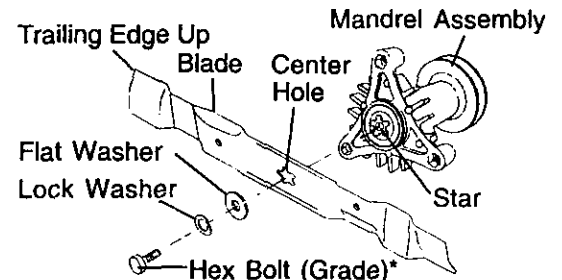

*A Grade 8 heat treated bolt can be identified by six lines on the bolt head.

TO SHARPEN BLADE

NOTE: We do not recommend sharpening blade - but if you do, be sure the blade is balanced.

Care should be taken to keep the blade balanced. An unbalanced blade will cause excessive vibration and eventual damage to mower and engine.

- The blade can be sharpened with a file or on a grinding wheel. Do not attempt to sharpen while on the mower.
- To check blade balance, you will need a 5/8" diameter steel bolt, pin, or a cone balancer. (When using a cone balancer, follow the instructions supplied with balancer.)

NOTE: Do not use a nail for balancing blade. The lobes of the center hole may appear to be centered, but are not.

- Slide blade on to an unthreaded portion of the steel bolt or pin and hold the bolt or pin parallel with the ground. If blade is balanced, it should remain in a horizontal position. If either end of the blade moves downward, sharpen the heavy end until the blade is balanced.

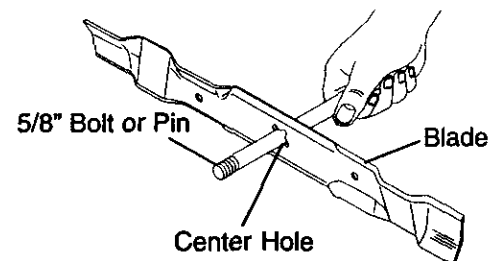

BATTERY

Your tractor has a battery charging system which is sufficient for normal use. However, periodic charging of the battery with an automotive charger will extend its life.

- Keep battery and terminals clean.
- Keep battery bolts tight.
- Keep small vent holes open.
- Recharge at 6-10 amperes for 1 hour.

NOTE: The original equipment battery on your tractor is maintenance free. Do not attempt to open or remove caps or covers. Adding or checking level of electrolyte is not necessary.

TO CLEAN BATTERY AND TERMINALS

Corrosion and dirt on the battery and terminals can cause the battery to "leak" power.

1. Open battery box door.
2. Disconnect BLACK battery cable first then RED battery cable and remove battery from tractor.
3. Rinse the battery with plain water and dry.
4. Clean terminals and battery cable ends with wire brush until bright.
5. Coat terminals with grease or petroleum jelly.
6. Reinstall battery (See "REPLACING BATTERY" in the SERVICE AND ADJUSTMENTS section of this manual).

TRANSAXLE COOLING

Keep transaxle free from build-up of dirt and chaff which can restrict cooling.

V-BELTS

Check V-belts for deterioration and wear after 100 hours of operation and replace if necessary. The belts are not adjustable. Replace belts if they begin to slip from wear.

ENGINE

LUBRICATION

Only use high quality detergent oil rated with API service classification SF-SJ. Select the oil's SAE viscosity grade according to your expected operating temperature.

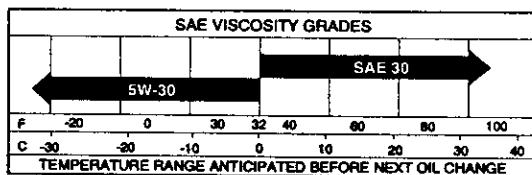

NOTE: Although multi-viscosity oils (5W30, 10W30 etc.) improve starting in cold weather, these multi-viscosity oils will result in increased oil consumption when used above 32°F. Check your engine oil level more frequently to avoid possible engine damage from running low on oil.

Change the oil after every 25 hours of operation or at least once a year if the tractor is not used for 25 hours in one year.

Check the crankcase oil level before starting the engine and after each eight (8) hours of operation. Tighten oil fill cap/dipstick securely each time you check the oil level.

TO CHANGE ENGINE OIL

Determine temperature range expected before oil change. All oil must meet API service classification SF-SJ.

- Be sure tractor is on level surface.
 - Oil will drain more freely when warm.
 - Catch oil in a suitable container.
1. Remove oil fill cap/dipstick. Be careful not to allow dirt to enter the engine when changing oil.
 2. Remove drain plug.
 3. After oil has drained completely, replace oil drain plug and tighten securely.
 4. Refill engine with oil through oil fill dipstick tube. Pour slowly. Do not overfill. For approximate capacity see "PRODUCT SPECIFICATIONS" section of this manual.
 5. Use gauge on oil fill cap/dipstick for checking level. Be sure dipstick cap is tightened securely for accurate reading. Keep oil at "FULL" line on dipstick.

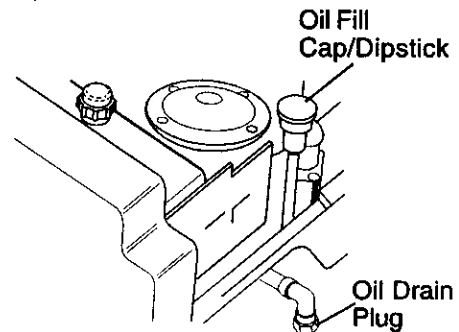

AIR FILTER

Your engine will not run properly using a dirty air filter. Clean the foam pre-cleaner after every 25 hours of operation or every season. Service paper cartridge every 100 hours of operation or every season, whichever occurs first.

Service air cleaner more often under dusty conditions.

1. Remove knob(s) and cover.

TO SERVICE PRE-CLEANER

2. Slide foam pre-cleaner off cartridge.
3. Wash it in liquid detergent and water.
4. Squeeze it dry in a clean cloth.
5. Saturate it in engine oil. Wrap it in clean, absorbent cloth and squeeze to remove excess oil.

NOTE: If very dirty or damaged, replace pre-cleaner.

6. Reinstall pre-cleaner over cartridge.
7. Reinstall cover and secure with knob(s).

TO SERVICE CARTRIDGE

1. Remove cartridge nut.
2. Carefully remove cartridge to prevent debris from entering carburetor. Clean base carefully to prevent debris from entering carburetor.
3. Clean cartridge by tapping gently on flat surface.

NOTE: If very dirty or damaged, replace cartridge.

4. Reinstall cartridge, nut, pre-cleaner, cover and secure with knob(s).

IMPORTANT: Petroleum solvents, such as kerosene, are not to be used to clean the cartridge. They may cause deterioration of the cartridge. Do not oil cartridge. Do not use pressurized air to clean or dry cartridge.

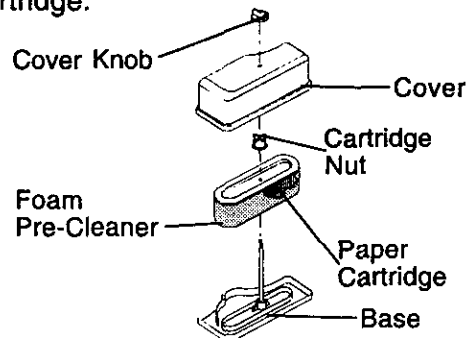

CLEAN AIR SCREEN

Air screen must be kept free of dirt and chaff to prevent engine damage from overheating. Clean with a wire brush or compressed air to remove dirt and stubborn dried gum fibers.

ENGINE COOLING FINS

Remove any dust, dirt or oil from engine cooling fins to prevent engine damage from overheating.

1. Remove screws from blower housing and lift housing and dipstick tube assembly off engine.
2. Cover oil fill opening to prevent entry of dirt.
3. Use compressed air or stiff bristle brush to thoroughly clean engine cooling fins.
4. To reassemble, reverse above procedure.

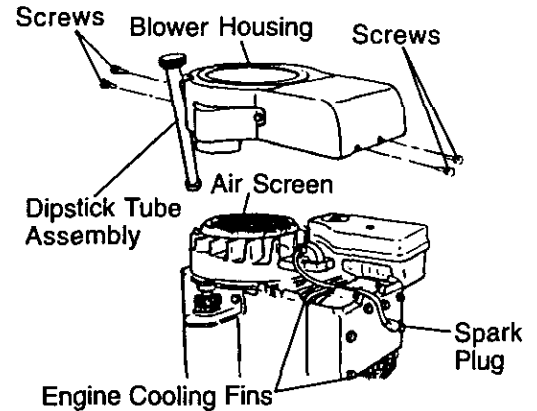

MUFFLER

Inspect and replace corroded muffler and spark arrester (if equipped) as it could create a fire hazard and/or damage.

SPARK PLUG(S)

Replace spark plug(s) at the beginning of each mowing season or after every 100 hours of operation, whichever occurs first. Spark plug type and gap setting are shown in "PRODUCT SPECIFICATIONS" section of this manual.

IN-LINE FUEL FILTER

The fuel filter should be replaced once each season. If fuel filter becomes clogged, obstructing fuel flow to carburetor, replacement is required.

1. With engine cool, remove filter and plug fuel line sections.
2. Place new fuel filter in position in fuel line with arrow pointing towards carburetor.
3. Be sure there are no fuel line leaks and clamps are properly positioned.
4. Immediately wipe up any spilled gasoline.

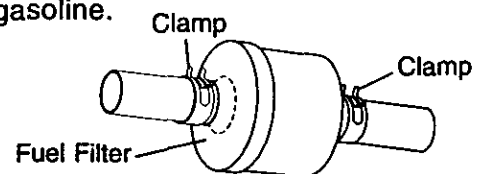

CLEANING

- Clean engine, battery, seat, finish, etc. of all foreign matter.
- Keep finished surfaces and wheels free of all gasoline, oil, etc.
- Protect painted surfaces with automotive type wax.

We do not recommend using a garden hose to clean your tractor unless the electrical system, muffler, air filter and carburetor are covered to keep water out. Water in engine can result in a shortened engine life.

SERVICE AND ADJUSTMENTS



WARNING: TO AVOID SERIOUS INJURY, BEFORE PERFORMING ANY SERVICE OR ADJUSTMENTS:

1. Depress clutch/brake pedal fully and set parking brake.
2. Place gearshift lever in neutral (N) position.
3. Place attachment clutch in "DISENGAGED" position.
4. Turn ignition key "OFF" and remove key.
5. Make sure the blades and all moving parts have completely stopped.
6. Disconnect spark plug wire from spark plug and place wire where it cannot come in contact with plug.

TRACTOR

TO REMOVE MOWER

Mower will be easier to remove from the right side of tractor.

1. Place attachment clutch in "DISENGAGED" position.
2. Move attachment lift lever forward to lower mower to its lowest position.
3. Roll belt off engine pulley.
4. Remove small retainer spring, and lift clutch spring off pulley bolt.
5. Remove large retainer spring, slide collar off and push housing guide out of bracket.
6. Disconnect anti-sway bar from chassis bracket by removing retainer spring.
7. Disconnect suspension arms from rear deck brackets by removing retainer springs.
8. Disconnect front links from deck by removing retainer springs.

9. Raise lift lever to raise suspension arms. Slide mower out from under tractor.

IMPORTANT: If an attachment other than the mower deck is to be mounted on the tractor, remove the front links and hook the clutch spring into square hole in frame.

TO INSTALL MOWER

1. Raise attachment lift lever to its highest position.
2. Slide mower under tractor with deflector shield to right side of tractor.
3. Lower lift lever to its lowest position.
4. Connect front links to mower deck and secure with retainer springs.

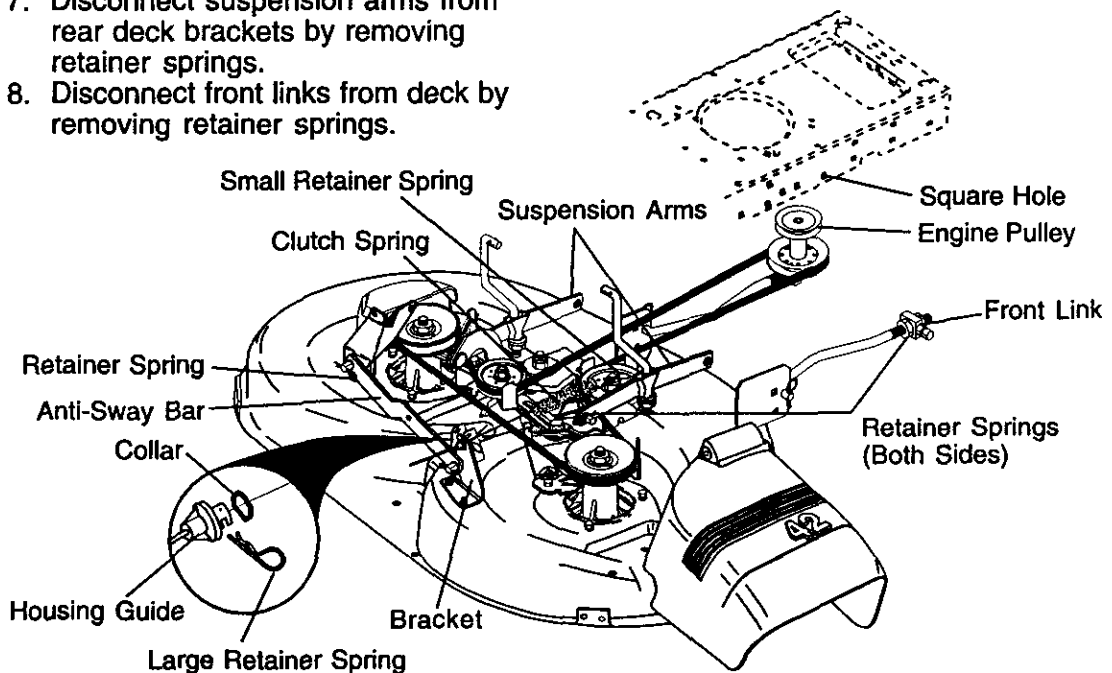

5. Connect suspension arms to rear deck brackets and secure with retainer springs.
6. Connect anti-sway bar to chassis bracket and secure with retainer spring.
7. Push clutch cable housing guide into bracket, slide collar onto guide and secure with large retainer spring.
8. Install belt onto engine pulley.

TO LEVEL MOWER HOUSING

Adjust the mower while tractor is parked on level ground or driveway. Make sure tires are properly inflated (See "PRODUCT SPECIFICATIONS" section of this manual). If tires are over or underinflated, you will not properly adjust your mower.

SIDE-TO-SIDE ADJUSTMENT

- Raise mower to its highest position.
- At the midpoint of both sides of mower, measure height from bottom edge of mower to ground. Distance "A" on both sides of mower should be the same or within 1/4" of each other.
- If adjustment is necessary, make adjustment on one side of mower only.
- To raise one side of mower, tighten lift link adjustment nut on that side.
- To lower one side of mower, loosen lift link adjustment nut on that side.

NOTE: Each full turn of adjustment nut will change mower height about 1/8".

- Recheck measurements after adjusting.

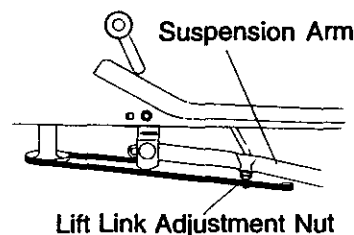
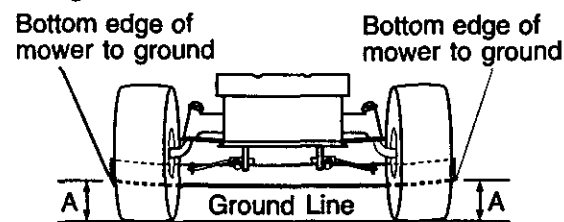

FRONT-TO-BACK ADJUSTMENT

IMPORTANT: Deck must be level side-to-side. If the following front-to-back adjustment is necessary, be sure to adjust both front links equally so mower will stay level side-to-side.

To obtain the best cutting results, the mower housing should be adjusted so that the front is approximately 1/8" to 1/2" lower than the rear when the mower is in its highest position.

Check adjustment on right side of tractor. Measure distance "D" directly in front and behind the mandrel at bottom edge of mower housing as shown.

- Before making any necessary adjustments, check that both front links are equal in length.
- If links are not equal in length, adjust one link to same length as other link.
- To lower front of mower loosen nut "E" on both front links an equal number of turns.
- When distance "D" is 1/8" to 1/2" lower at front than rear, tighten nuts "F" against trunnion on both front links.
- To raise front of mower, loosen nut "F" from trunnion on both front links. Tighten nut "E" on both front links an equal number of turns. The two front links must remain equal in length.
- When distance "D" is 1/8" to 1/2" lower at front than rear, tighten nut "F" against trunnion on both front links.
- Recheck side-to-side adjustment.

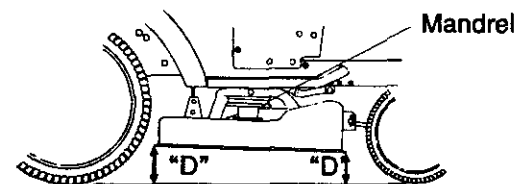

Both Front Links Should be Equal in Length

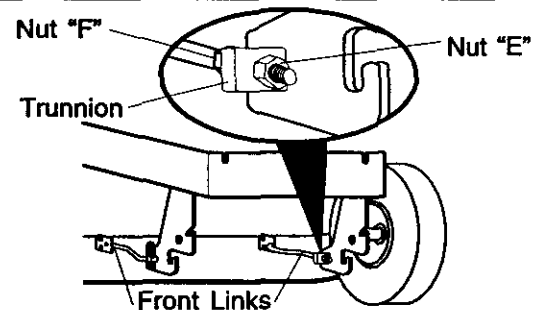
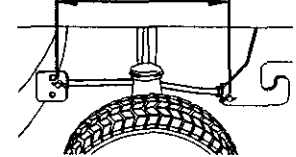

TO REPLACE MOWER BLADE DRIVE BELT

The mower blade drive belt may be replaced without tools. Park the tractor on level surface. Engage parking brake.

BELT REMOVAL -

1. Remove mower from tractor (See "TO REMOVE MOWER" in this section of manual).
2. Work belt off both mandrel pulleys and idler pulleys.
3. Pull belt away from mower.

BELT INSTALLATION -

1. Work belt around both mandrel pulleys and idler pulleys
2. Make sure belt is in all pulley grooves and inside all belt guides.
3. Install mower (See "To Install Mower" in this section of this manual).

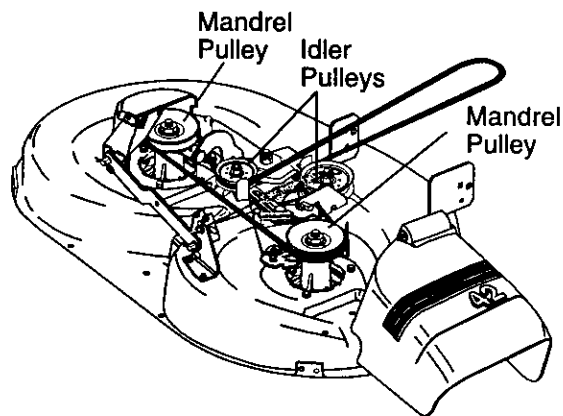

TO ADJUST BRAKE

Your tractor is equipped with an adjustable brake system which is mounted on the right side of the transaxle.

If tractor requires more than six (6) feet stopping distance at high speed in highest gear on a level dry concrete or paved surface, then brake must be adjusted.

1. Depress clutch/brake pedal and engage parking brake.
2. Measure distance between brake operating arm and nut "A" on brake rod.
3. If distance is other than 1-1/2", loosen jam nut and turn nut "A" until distance becomes 1-1/2". Retighten jam nut against nut "A".

4. Road test tractor for proper stopping distance as stated above. Readjust if necessary. If stopping distance is still greater than six (6) feet in highest gear, further maintenance is necessary. Contact a Sears or other qualified service center.

With Parking Brake "Engaged"

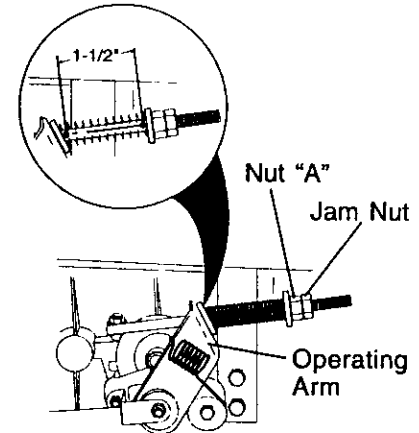

TO REPLACE MOTION DRIVE BELT

Park the tractor on level surface. Engage parking brake. For assistance, there is a belt installation guide decal on bottom side of left footrest.

BELT REMOVAL -

1. Remove mower (See "TO REMOVE MOWER" in this section of manual).
- NOTE:** Observe entire motion drive belt and position of all belt guides and keepers.
2. Remove belt from stationary idler and clutching idler.
3. Remove belt downward from around engine pulley.
4. Pull belt slack toward rear of tractor. Remove belt upwards from transaxle pulley by deflecting belt keepers.
5. Remove belt from center span keeper and pull belt away from tractor.

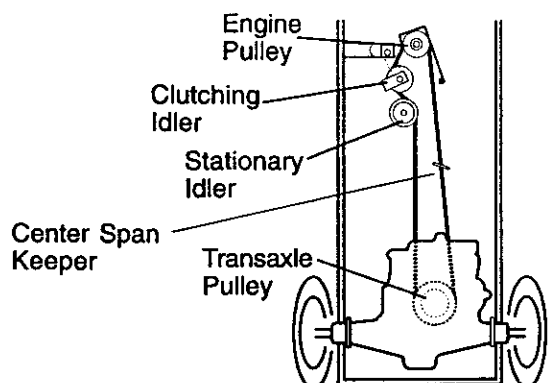

BELT INSTALLATION -

1. Carefully work new belt down between transaxle belt keepers and onto the input pulley.
2. Slide belt into the center span keeper.
3. Pull belt toward front of tractor and roll around the top groove of engine pulley.
4. Install belt through stationary idler and clutching idler.
5. Make sure belt is in all pulley grooves and inside all belt guides and keepers.
6. Install mower (See "TO INSTALL MOWER" in this section of manual).

TO ADJUST STEERING WHEEL ALIGNMENT

If steering wheel crossbars are not horizontal (left to right) when wheels are positioned straight forward, remove steering wheel and reassemble with crossbars horizontal. Tighten securely.

FRONT WHEEL TOE-IN/CAMBER

The front wheel toe-in and camber are not adjustable on your tractor. If damage has occurred to affect the front wheel toe-in or camber, contact a Sears or other qualified service center.

TO REMOVE WHEEL FOR REPAIRS

1. Block up axle securely.
2. Remove axle cover, retaining ring and washers to allow wheel removal (rear wheels have a square key - Do not lose).
3. Repair tire and reassemble.

NOTE: On rear wheels only: align grooves in rear wheel hub and axle. Insert square key.

4. Replace washers and snap retaining ring securely in axle groove.
5. Replace axle cover.

NOTE: To seal tire punctures and prevent flat tires due to slow leaks, purchase and use tire sealant from Sears. Tire sealant also prevents tire dry rot and corrosion.

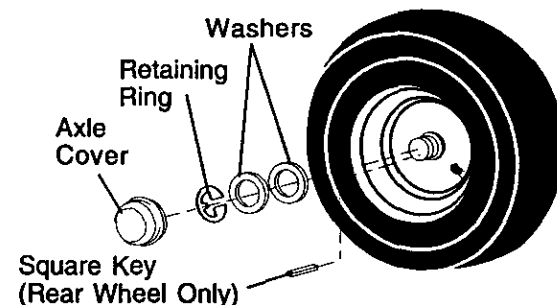

TO START ENGINE WITH A WEAK BATTERY

WARNING: Lead-acid batteries generate explosive gases. Keep sparks, flame and smoking materials away from batteries. Always wear eye protection when around batteries.

If your battery is too weak to start the engine, it should be recharged. (See "BATTERY" in the MAINTENANCE section of this manual).

If "jumper cables" are used for emergency starting, follow this procedure:

IMPORTANT: Your tractor is equipped with a 12 volt system. The other vehicle must also be a 12 volt system. Do not use your tractor battery to start other vehicles.

TO ATTACH JUMPER CABLES -

1. Connect one end of the RED cable to the POSITIVE (+) terminal of each battery(A-B), taking care not to short against tractor chassis.
2. Connect one end of the BLACK cable to the NEGATIVE (-) terminal (C) of fully charged battery.
3. Connect the other end of the BLACK cable (D) to good chassis ground, away from fuel tank and battery.

TO REMOVE CABLES, REVERSE ORDER -

1. BLACK cable first from chassis and then from the fully charged battery.
2. RED cable last from both batteries.

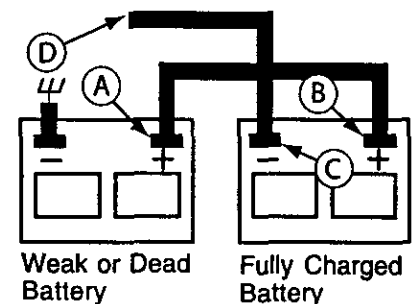

REPLACING BATTERY

⚠WARNING: Do not short battery terminals by allowing a wrench or any other object to contact both terminals at the same time. Before connecting battery, remove metal bracelets, wristwatch bands, rings, etc.

Positive terminal must be connected first to prevent sparking from accidental grounding.

1. Lift seat pan to raised position.
2. Disconnect BLACK battery cable first then RED battery cable and carefully remove battery from tractor.
3. Install new battery with terminals in same position as old battery.
4. First connect RED battery cable to positive (+) terminal with hex bolt and keps nut as shown. Tighten securely. Slide terminal cover over terminal.
5. Connect BLACK grounding cable to negative (-) terminal with remaining hex bolt and keps nut. Tighten securely.

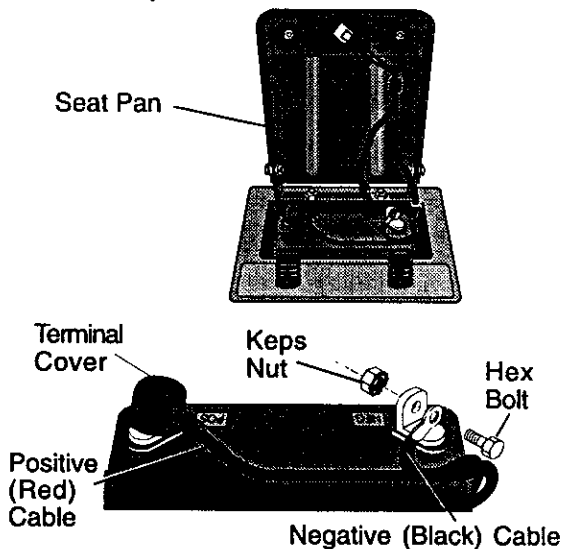

TO REPLACE HEADLIGHT BULB

1. Raise hood.
2. Pull bulb holder out of the hole in the backside of the grill.
3. Replace bulb in holder and push bulb holder securely back into the hole in the backside of the grill.
4. Close hood.

INTERLOCKS AND RELAYS

Loose or damaged wiring may cause your tractor to run poorly, stop running, or prevent it from starting.

- Check wiring. See electrical wiring diagram in the Repair Parts section.

TO REPLACE FUSE

Replace with 20 amp automotive-type plug-in fuse. The fuse holder is located behind the dash.

TO REMOVE HOOD AND GRILL ASSEMBLY

1. Raise hood.
2. Unsnap headlight wire connector.
3. Stand in front of tractor. Grasp hood at sides, tilt toward engine and lift off of tractor.
4. When replacing hood, be sure to reconnect headlight wire connector.

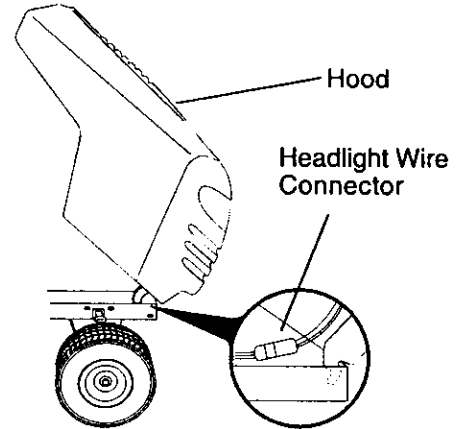

ENGINE

Maintenance, repair, or replacement of the emission control devices and systems, which are being done at the customer's expense, may be performed by any non-road engine repair establishment or individual. Warranty repairs must be performed by an authorized engine manufacturer's service outlet.

TO ADJUST THROTTLE CONTROL CABLE

The throttle control has been preset at the factory and adjustment should not be necessary. Check adjustment as described below before loosening cable. If adjustment is necessary, proceed as follows:

1. With engine not running, move throttle control lever from slow to choke position. Slowly move lever from choke to fast position.

2. Check that holes "A" in governor control lever and hole in governor plate line-up. If holes "A" are not aligned, loosen clamp screw and move throttle cable until holes are aligned. Tighten clamp screw securely.

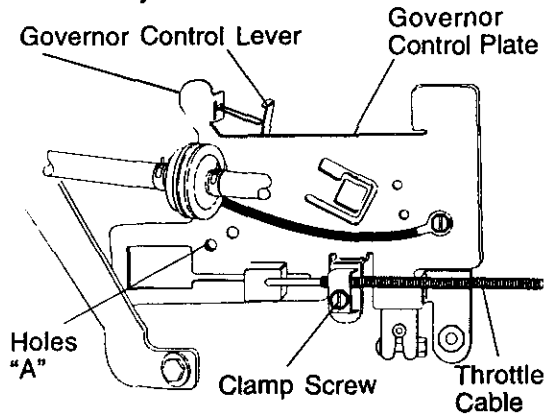

TO ADJUST CARBURETOR

NOTE: The carburetor on this engine is low emission. It is equipped with an idle fuel adjusting needle with a limiter cap, which allows some adjustment within the limits allowed by the cap. Do not attempt to remove the limiter cap. The limiter cap cannot be removed without breaking the adjusting needle.

The carburetor has been preset at the factory and adjustment should not be necessary. However, minor adjustment may be required to compensate for differences in fuel, temperature, altitude or load. If the carburetor does need adjustment, proceed as follows: In general, turning idle mixture valve **in** (clockwise) decreases the supply of fuel to the engine giving a leaner fuel/air mixture. Turning the idle mixture valve **out** (counterclockwise) increases the supply of fuel to the engine giving a richer fuel/air mixture.

IMPORTANT: Damage to the needle valve and the seat in carburetor may result if screw is turned in too tight.

PRELIMINARY SETTING -

1. Air cleaner assembly must be assembled to the carburetor when making carburetor adjustments.
2. Be sure the throttle control cable is adjusted properly (see above).

FINAL SETTING -

1. Start engine and allow to warm for five minutes. Make final adjustments with engine running and shift/motion control lever in neutral (N) position.
2. Move throttle control lever to slow position. With finger, rotate and hold throttle lever against idle speed screw. Turn idle speed screw to attain 1750 RPM.
3. While still holding throttle lever against idle speed screw, turn idle mixture valve full travel clockwise then counterclockwise until engine runs rough. Turn valve to a point midway between those two positions. Release throttle lever.

ACCELERATION TEST -

4. Move throttle control lever from slow to fast position. If engine hesitates or dies, turn idle mixture valve **out** (counterclockwise) 1/8 turn. Repeat test and continue to adjust, if necessary, until engine accelerates smoothly.

High speed stop is factory adjusted. Do not adjust or damage may result.

IMPORTANT: Never tamper with the engine governor, which is factory set for proper engine speed. Overspeeding the engine above the factory high speed setting can be dangerous. If you think the engine-governed high speed needs adjusting, contact a Sears or other qualified service center, which has proper equipment and experience to make any necessary adjustments.

Idle Speed Screw

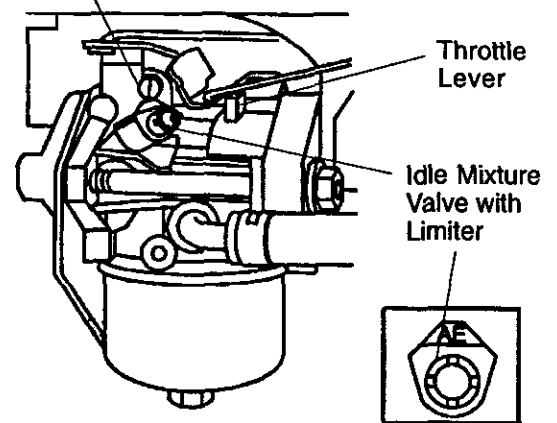

STORAGE

Immediately prepare your tractor for storage at the end of the season or if the tractor will not be used for 30 days or more.

⚠CAUTION: Never store the tractor with gasoline in the tank inside a building where fumes may reach an open flame or spark. Allow the engine to cool before storing in any enclosure.

TRACTOR

Remove mower from tractor for winter storage. When mower is to be stored for a period of time, clean it thoroughly, remove all dirt, grease, leaves, etc. Store in a clean, dry area.

1. Clean entire tractor (See "CLEANING" in the Maintenance section of this manual).
2. Inspect and replace belts, if necessary (See belt replacement instructions in the Service and Adjustments section of this manual).
3. Lubricate as shown in the Maintenance section of this manual.
4. Be sure that all nuts, bolts and screws are securely fastened. Inspect moving parts for damage, breakage and wear. Replace if necessary.
5. Touch up all rusted or chipped paint surfaces; sand lightly before painting.

BATTERY

- Fully charge the battery for storage.
- After a period of time in storage, battery may require recharging.
- To help prevent corrosion and power leakage during long periods of storage, battery cables should be disconnected and battery cleaned thoroughly (see "TO CLEAN BATTERY AND TERMINALS" in the Maintenance section of this manual).
- After cleaning, leave cables disconnected and place cables where they cannot come in contact with battery terminals.
- If battery is removed from tractor for storage, do not store battery directly on concrete or damp surfaces.

ENGINE

FUEL SYSTEM

IMPORTANT: It is important to prevent gum deposits from forming in essential fuel system parts such as carburetor, fuel hose, or tank during storage.

Also, alcohol blended fuels (called gasohol or using ethanol or methanol) can attract moisture which leads to separation and formation of acids during storage. Acidic gas can damage the fuel system of an engine while in storage.

1. Drain the fuel tank.
 2. Start the engine and let it run until the fuel lines and carburetor are empty.
- Never use engine or carburetor cleaner products in the fuel tank or permanent damage may occur.
 - Use fresh fuel next season.

NOTE: Fuel stabilizer is an acceptable alternative in minimizing the formation of fuel gum deposits during storage. Add stabilizer to gasoline in fuel tank or storage container. Always follow the mix ratio found on stabilizer container. Run engine at least 10 minutes after adding stabilizer to allow the stabilizer to reach the carburetor. Do not drain the gas tank and carburetor if using fuel stabilizer.

ENGINE OIL

Drain oil (with engine warm) and replace with clean engine oil. (See "ENGINE" in the Maintenance section of this manual).

CYLINDER(S)

1. Remove spark plug(s).
2. Pour one ounce of oil through spark plug hole(s) into cylinder(s).
3. Turn ignition key to start position for a few seconds to distribute oil.
4. Replace with new spark plug(s).

OTHER

- Do not store gasoline from one season to another.
- Replace your gasoline can if your can starts to rust. Rust and/or dirt in your gasoline will cause problems.
- If possible, store your tractor indoors and cover it to give protection from dust and dirt.
- Cover your tractor with a suitable protective cover that does not retain moisture. Do not use plastic. Plastic cannot breathe which allows condensation to form and will cause your tractor to rust.

IMPORTANT: Never cover tractor while engine and exhaust areas are still warm.

TROUBLESHOOTING CHART:

See appropriate section in manual unless directed to Sears service center

PROBLEM	CAUSE	CORRECTION
Will not start	<ol style="list-style-type: none"> 1. Out of fuel. 2. Engine not "CHOKED" properly. 3. Engine flooded. 4. Bad spark plug. 5. Dirty air filter. 6. Dirty fuel filter. 7. Water in fuel. 8. Loose or damaged wiring. 9. Carburetor out of adjustment. 10. Engine valves out of adjustment. 	<ol style="list-style-type: none"> 1. Fill fuel tank. 2. See "TO START ENGINE" in Operation section. 3. Wait several minutes before attempting to start. 4. Replace spark plug. 5. Clean/replace air filter. 6. Replace fuel filter. 7. Drain fuel tank and carburetor, refill tank with fresh gasoline and replace fuel filter. 8. Check all wiring. 9. See "To Adjust Carburetor" in Service and Adjustments section. 10. Contact a Sears or other qualified service center.
Hard to start	<ol style="list-style-type: none"> 1. Dirty air filter. 2. Bad spark plug. 3. Weak or dead battery. 4. Dirty fuel filter. 5. Stale or dirty fuel. 6. Loose or damaged wiring. 7. Carburetor out of adjustment. 8. Engine valves out of adjustment. 	<ol style="list-style-type: none"> 1. Clean/replace air filter. 2. Replace spark plug. 3. Recharge or replace battery. 4. Replace fuel filter. 5. Drain fuel tank and refill with fresh gasoline. 6. Check all wiring. 7. See "To Adjust Carburetor" in Service and Adjustments section. 8. Contact a Sears or other qualified service center.
Engine will not turn over	<ol style="list-style-type: none"> 1. Clutch/brake pedal not depressed. 2. Attachment clutch is engaged. 3. Weak or dead battery. 4. Blown fuse. 5. Corroded battery terminals. 6. Loose or damaged wiring. 7. Faulty ignition switch. 8. Faulty solenoid or starter. 9. Faulty operator presence switch(es). 	<ol style="list-style-type: none"> 1. Depress clutch/brake pedal. 2. Disengage attachment clutch. 3. Recharge or replace battery. 4. Replace fuse. 5. Clean battery terminals. 6. Check all wiring. 7. Check/replace ignition switch. 8. Check/replace solenoid or starter. 9. Contact a Sears or other qualified service center.
Engine clicks but will not start	<ol style="list-style-type: none"> 1. Weak or dead battery. 2. Corroded battery terminals. 3. Loose or damaged wiring. 4. Faulty solenoid or starter. 	<ol style="list-style-type: none"> 1. Recharge or replace battery. 2. Clean battery terminals. 3. Check all wiring. 4. Check/replace solenoid or starter.

TROUBLESHOOTING CHART:

See appropriate section in manual unless directed to Sears service center

PROBLEM	CAUSE	CORRECTION
Loss of power	<ol style="list-style-type: none"> 1. Cutting too much grass/too fast. 2. Throttle in "CHOKE" position. 3. Build-up of grass, leaves and trash under mower. 4. Dirty air filter. 5. Low oil level/dirty oil. 6. Faulty spark plug. 7. Dirty fuel filter. 8. Stale or dirty fuel. 9. Water in fuel. 10. Spark plug wire loose. 11. Dirty engine air screen/fins. 12. Dirty/clogged muffler. 13. Loose or damaged wiring. 14. Carburetor out of adjustment. 15. Engine valves out of adjustment. 	<ol style="list-style-type: none"> 1. Set in "Higher Cut" position/ reduce speed. 2. Adjust throttle control. 3. Clean underside of mower housing. 4. Clean/replace air filter. 5. Check oil level/change oil. 6. Clean and regap or change spark plug. 7. Replace fuel filter. 8. Drain fuel tank and refill with fresh gasoline. 9. Drain fuel tank and carburetor, refill tank with fresh gasoline and replace fuel filter. 10. Connect and tighten spark plug wire. 11. Clean engine air screen/fins. 12. Clean/replace muffler. 13. Check all wiring. 14. See "To Adjust Carburetor" in Service and Adjustments section. 15. Contact a Sears or other qualified service center.
Excessive vibration	<ol style="list-style-type: none"> 1. Worn, bent or loose blade. 2. Bent blade mandrel. 3. Loose/damaged part(s). 	<ol style="list-style-type: none"> 1. Replace blade. Tighten blade bolt. 2. Contact a Sears or other qualified service center. 3. Tighten loose part(s). Replace damaged parts.
Engine continues to run when operator leaves seat with attachment clutch engaged	<ol style="list-style-type: none"> 1. Faulty operator-safety presence control system. 	<ol style="list-style-type: none"> 1. Check wiring, switches and connections. If not contact a Sears or other qualified service center.
Poor cut - uneven	<ol style="list-style-type: none"> 1. Worn, bent or loose blade. 2. Mower deck not level. 3. Buildup of grass, leaves, and trash under mower. 4. Bent blade mandrel. 5. Clogged mower deck vent holes from buildup of grass, leaves, and trash around mandrels. 	<ol style="list-style-type: none"> 1. Replace blade. Tighten blade bolt. 2. Level mower deck. 3. Clean underside of mower housing. 4. Contact a Sears or other qualified service center. 5. Clean around mandrels to open vent holes.

TROUBLESHOOTING CHART:

See appropriate section in manual unless directed to Sears service center

PROBLEM	CAUSE	CORRECTION
Mower blades will not rotate	<ol style="list-style-type: none"> 1. Obstruction in clutch mechanism. 2. Worn/damaged mower drive belt. 3. Frozen idler pulley. 4. Frozen blade mandrel. 	<ol style="list-style-type: none"> 1. Remove obstruction. 2. Replace mower drive belt. 3. Replace idler pulley. 4. Contact a Sears or other qualified service center.
Poor grass discharge	<ol style="list-style-type: none"> 1. Engine speed too slow. 2. Travel speed too fast. 3. Wet grass. 4. Mower deck not level. 5. Low/uneven tire air pressure. 6. Worn, bent or loose blade. 7. Buildup of grass, leaves and trash under mower. 8. Mower drive belt worn. 9. Blades improperly installed. 10. Improper blades used. 11. Clogged mower deck vent holes from buildup of grass, leaves, and trash around mandrels. 	<ol style="list-style-type: none"> 1. Place throttle control in "FAST" position. 2. Shift to slower speed. 3. Allow grass to dry before mowing. 4. Level mower deck. 5. Check tires for proper air pressure. 6. Replace/sharpen blade. Tighten blade bolt. 7. Clean underside of mower housing. 8. Replace mower drive belt. 9. Reinstall blades sharp edge down. 10. Replace with blades listed in this manual. 11. Clean around mandrels to open vent holes.
Headlight(s) not working (if so equipped)	<ol style="list-style-type: none"> 1. Switch is "OFF". 2. Bulb(s) or lamp(s) burned out. 3. Faulty light switch. 4. Loose or damaged wiring. 5. Blown fuse. 	<ol style="list-style-type: none"> 1. Turn switch "ON". 2. Replace bulb(s) or lamp(s). 3. Check/replace light switch. 4. Check wiring and connections. 5. Replace fuse.
Battery will not charge	<ol style="list-style-type: none"> 1. Bad battery cell(s). 2. Poor cable connections. 3. Faulty regulator (if so equipped). 4. Faulty alternator. 	<ol style="list-style-type: none"> 1. Replace battery. 2. Check/clean all connections. 3. Replace regulator. 4. Replace alternator.
Engine "backfires" when turning engine "OFF"	<ol style="list-style-type: none"> 1. Engine throttle control not set at "SLOW" position for 30 seconds before stopping engine. 	<ol style="list-style-type: none"> 1. Move throttle control to "SLOW" position and allow to idle for 30 seconds before stopping engine.

TRACTOR -- MODEL NUMBER 917.271552

SCHEMATIC

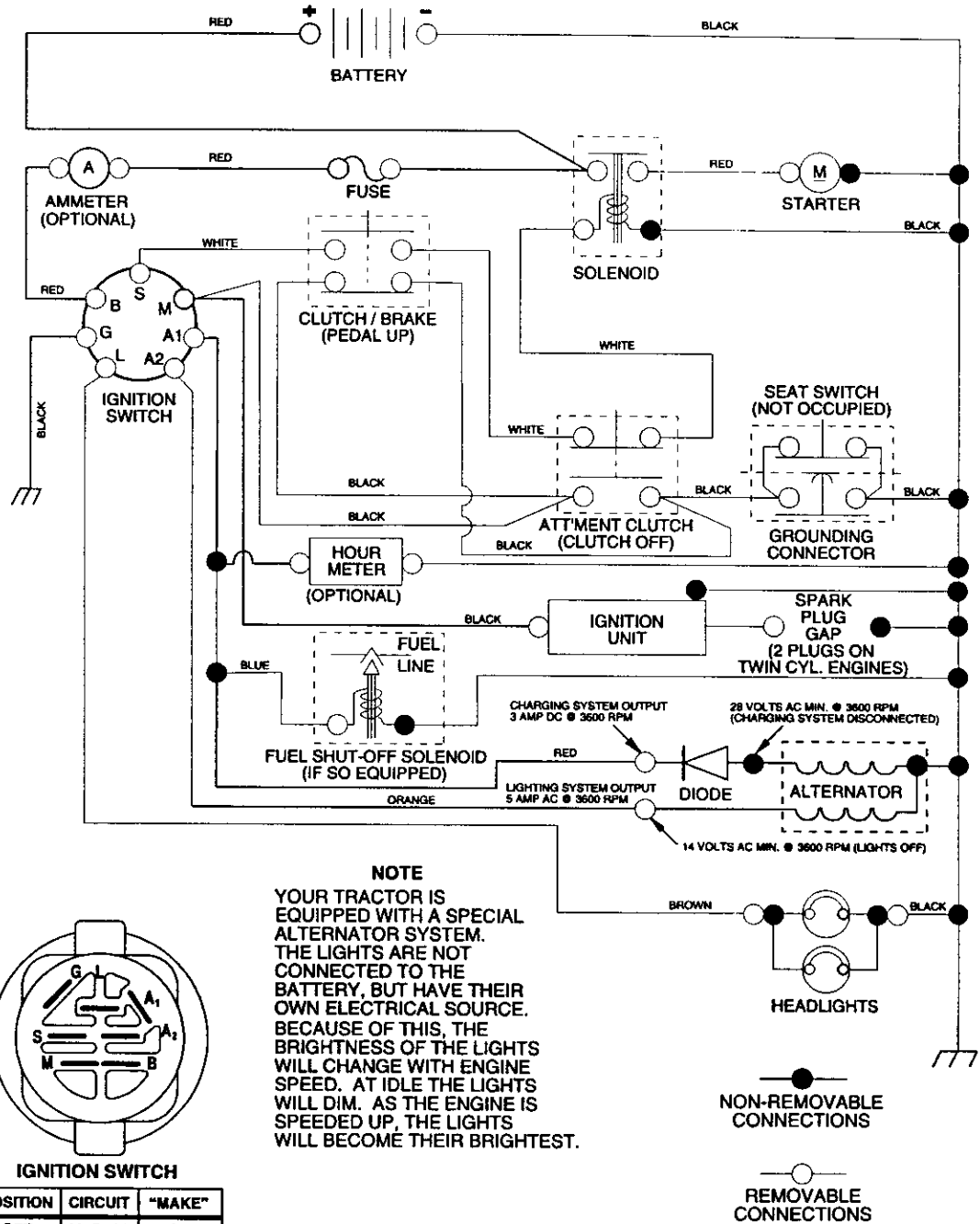

REPAIR PARTS

TRACTOR – MODEL NUMBER 917.271552

ELECTRICAL

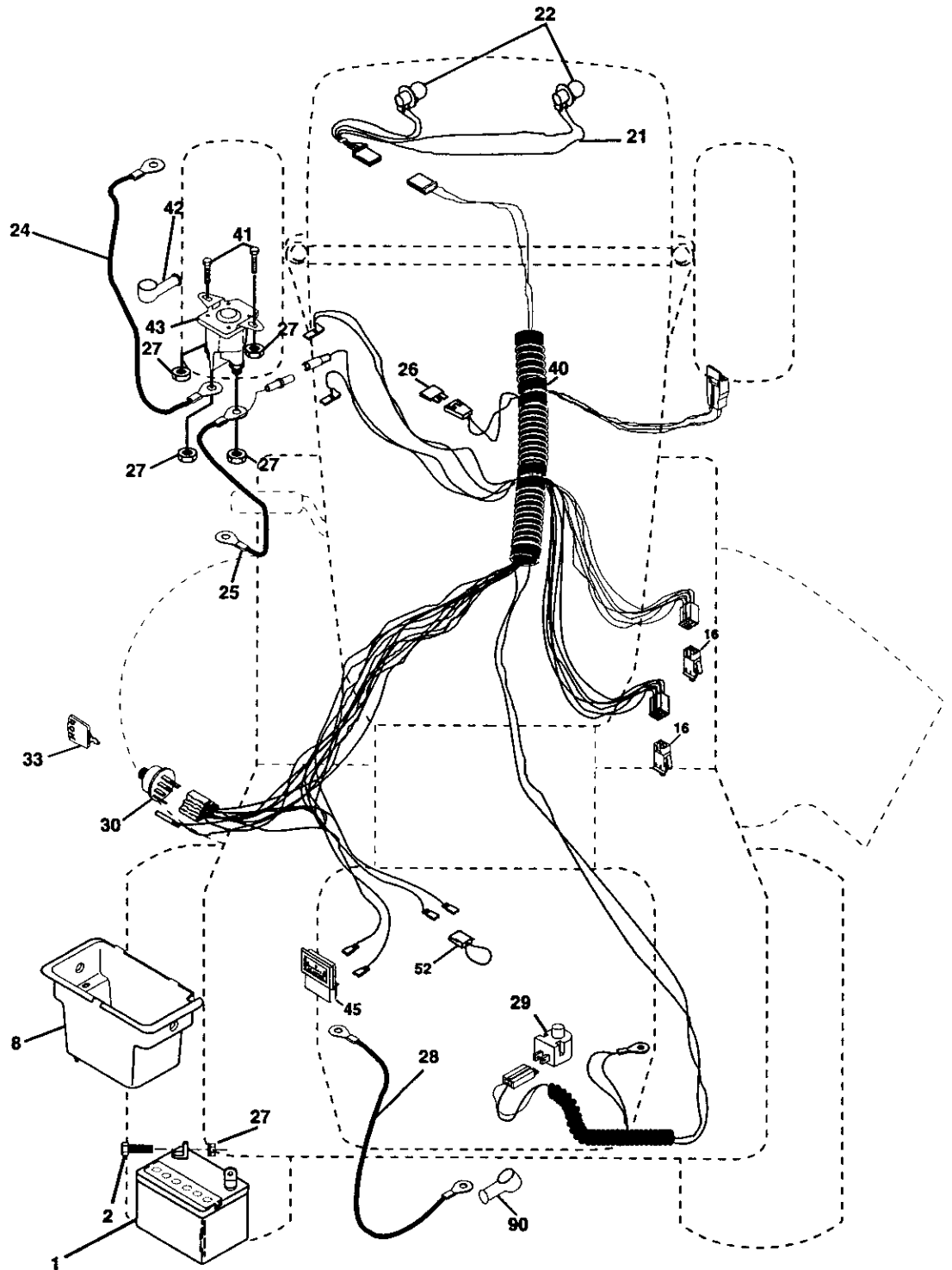

ELECTRICAL**TRACTOR – MODEL NUMBER 917.271552**

KEY PART NO.	PART NO.	DESCRIPTION
1	163465	Battery
2	74760412	Bolt Hex Hd 1/4-20unc X 3/4
8	176689	Box Battery Fender
16	176138	Switch Interlock
21	175685	Harness Socket Light W/4152J
22	4152J	Bulb Light #1156
24	4799J	Cable Battery 6ga 11" red
25	146147	Cable Battery 6 Ga W/16 Wir red
26	175158	Fuse 20 AMP
27	73510400	Nut Keps Hex 1/4-20 Unc
28	4207J	Cable Ground 6ga 12" black
29	121305X	Switch Plunger Nc Gray
30	175566	Switch Ign Delta Push-in
33	140403	Key Ign Molded Craftsman, Delta
40	179720	Harness Ign
41	71110408	Bolt Blk Hex 1/4-20unc x 1/2
42	131563	Cover Terminal Red
43	178861	Solenoid
45	121433X	Ammeter Rectangular 6 AMP
52	141940	Protection Wire Loop
89	180449	Cover Terminal Battery

NOTE: All component dimensions given in U. S. inches
1 inch = 25.4 mm

TRACTOR – MODEL NUMBER 917.271552
CHASSIS AND ENCLOSURES

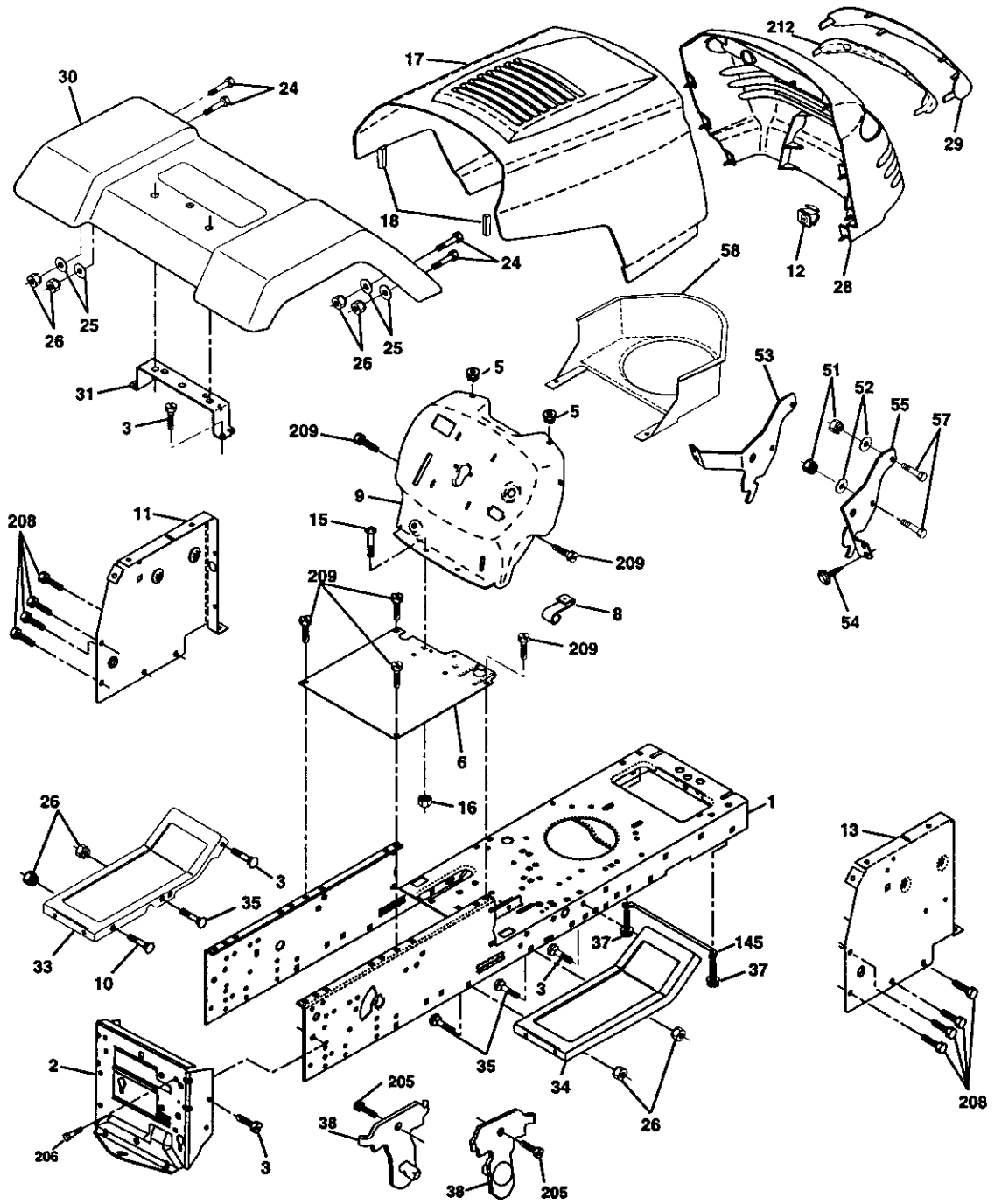

**TRACTOR – MODEL NUMBER 917.271552
CHASSIS AND ENCLOSURES**

KEY NO.	PART NO.	DESCRIPTION
1	174620	Chassis Lt Stamping
2	176554	Drawbar
3	17060612	Screw 3/8-16 x 3/4
5	155272	BumperHood/Dash
6	174643X010	Saddle SLKSCRE FLT SDL
8	126471X	Clip Insulator .406 Mtg Hole
9	168348X010	Dash Silkscr Plm Mech Sym
10	72140608	Bolt RdHd Sqnk. 3/8-16 x 1
11	155927	Panel Asm. Dash Lh
12	145660	Clip Tinnerman Grille P/L
13	172107X010	Panel Dash Rh
15	74180512	Screw Mach Trhd 5/16-18unc x 3/4
16	73510500	Nu Keps 5/16-18unc
17	159639X558	Hood Pnt Steel Private Label
18	126938X	BumperHood
24	74780616	Bolt Fin Hex 3/8-16 Unc x 1 Gr. 5
25	19131312	Washer 13/32 x 13/16 x 12 Ga.
26	73800600	Nut Lock Hex w/Ins 3/8-16 Unc
28	179101	Grill/Lens Asm
29	140273X599	Lens Grille
30	169465X558	Fender Pnt
31	136619	Bracket Fender Support
33	179716X558	Footrest Pnt. Lh
34	179717X558	Footrest Pnt. Rh
35	72110606	Bolt RdHd Sht. Sqnk. 3/8-16 x 3/4
37	17490508	Screw Thdrol 5/16-18 x 1/2 Tyt
38	175710	Bracket Asm. Pivot Mower Rear
51	73800400	Nut Lock Hex W/Ins. 1/4-20
52	19091416	Washer 9/32 x 7/8 x 16 Ga.
53	144697	Bracket Grille LH
54	161464	Screw Hex Wshd #8-18 x 7/8
55	144696	Bracket, Grille RH
57	74780412	Bolt Fin Hex 1/4-20 x 3/4
58	150127	Air Duct Private Label LT Engine
145	156524	Rod Pivot Chassis /Hood
205	17490608	Screw Thdrol 3/8-16 x 1/2
206	170165	Bolt Shoulder 5/16-18 TT
208	17670608	Screw Thdrol. 3/8-16 x 1/2
209	17000612	Screw Hex Wsh Thdrol 3/8-16 BL
212	156229	Insert Lens Reflective
--	5479J	Plug Button Blk .359 Dia. Choke

NOTE: All component dimensions given in U. S.
inches 1 inch = 25.4 mm

TRACTOR – MODEL NUMBER 917.271552
GROUND DRIVE

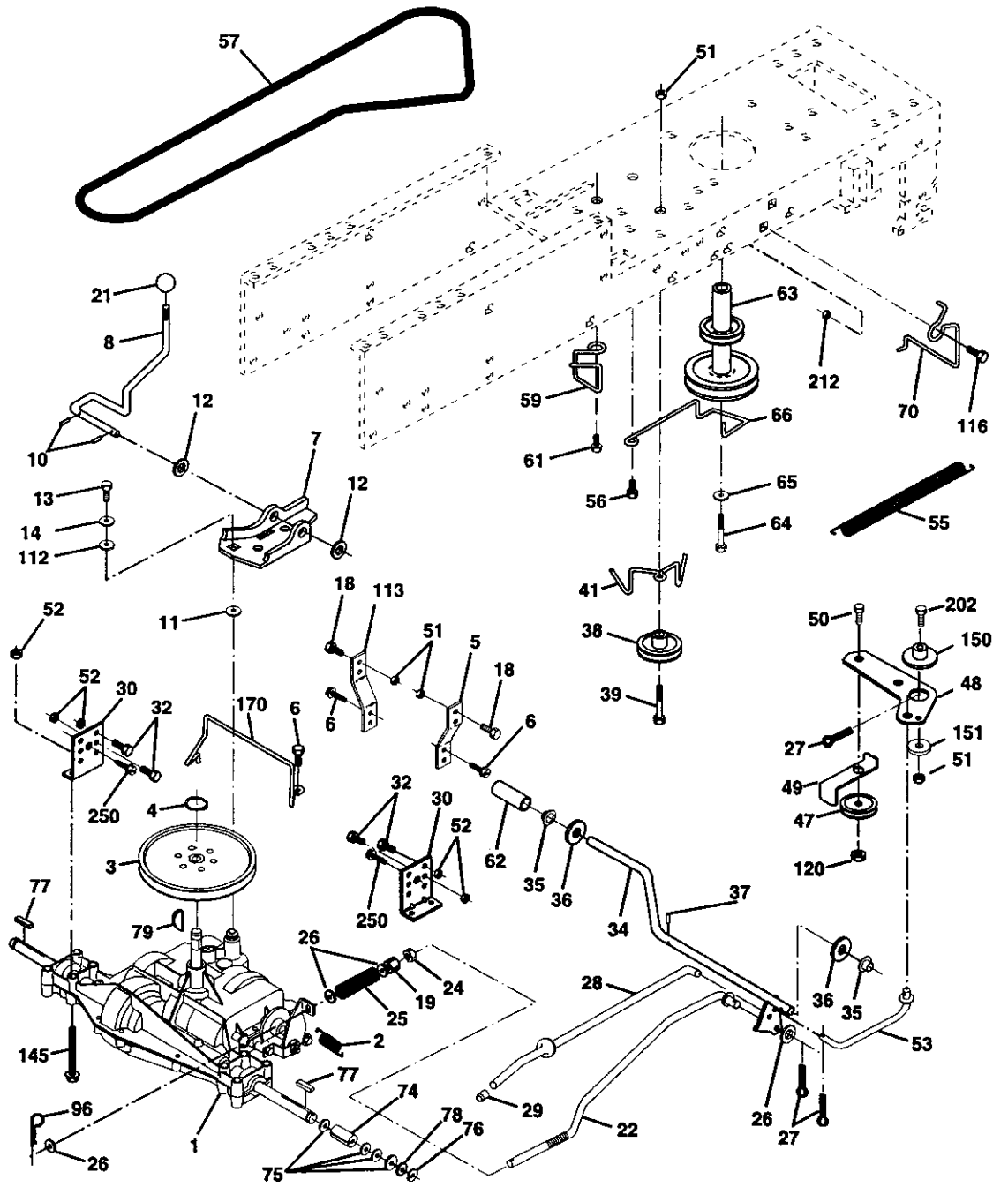

TRACTOR – MODEL NUMBER 917.271552

GROUND DRIVE

KEY PART NO.	PART NO.	DESCRIPTION	KEY PART NO.	PART NO.	DESCRIPTION
1	----	Transaxle (See Breakdown) Peerless 206-545C	50	STD523715	Bolt Hex Hd 3/8-16unc x 1-1/2
2	146682	Spring Return Brake T/a Zinc	51	STD541437	Nut Crownlock 3/8-16 UNC
3	123666X	Pulley Transaxle 18/20" tires	52	STD541431	Nut Crown Lock 5/16-18
4	12000028	Ring Retainer # 5100-62	53	105710X	Link Clutch 7 66
5	121520X	Strap Torque 30 Degrees	55	105709X	Spring Return Clutch 6 75
6	17060512	Screw 5/16-18 x 3/4	56	17060620	Screw 3/8-16 x 1-1/4
7	162240	Bracket Saddle Shift T/a	57	130801	V-Belt Gd Drive
8	131679	Rod Shf Sdl LY/YT Str Blk Zinc	59	169691	Keeper Belt Centerspan
10	STD561210	Pin Cotter 1/8 x 1 Cad	61	17120614	Screw 3/8-16 x .875
11	105701X	Washer Plate Shf 388 Sq Hole	62	8883R	Cover Pedal Blk Round
12	19151216	Washer 15/32 x 3/4 x 16ga	63	175410	Pulley Eng
13	74550412	Bolt 1/4-28unf Gr8 W/Patch	64	71170764	Bolt Hex 7/16-20 x 4 Gr 5
14	STD551125	Washer Lock Hvy Helical 1/4	65	STD551143	Washer Lock Hvy Hcl Spr 7/16
18	STD523710	Bolt Fin Hex 3/8-16 x 1	66	154778	Keeper Belt Engine
19	STD541437	Nut Lock Hex W/Ins. 3/8-16 Unc	70	134683	Guide Belt Mower Drive RH
21	106933X	Knob Rd 1/2-13 Plstc Thds Blk	74	137057	Spacer Axle
22	130804	Rod Brake Blk Zinc 26 840	75	121749X	Washer 25/32 x 1 1/4 x 16 Ga
24	STD541237	Nut Hex Jam 3/8-16 Unc	76	STD581075	E-ring #5133-75
25	106888X	Spring Rod Brake 2 00 Zinc	77	123583X	Key Square 2 0 x 1845/ 1865
26	19131316	Washer 13/32 x 13/16 x 16 Ga.	78	121748X	Washer 25/32 x 1-5/8 x 16 Ga
27	STD561210	Pin Cotter 1/8 x 3/4 Cad	79	2228M	Key
28	175765	Rod Brake Parking Lt/Yt	96	4497H	Retainer Spring 1.00
29	71673	Cap Brake Parking	112	19091210	Washer 9/32 x 3/4 x 10 Ga
30	174973	Bracket Mtg Transaxle	113	127285X	Strap Torque
32	STD523107	Bolt Hex Hd 5/16-18unc x 3/4	116	72140608	Bolt Rdhd Sq Neck 3/8-16 x 1
34	175578	Shaft Asm Pedal Foot	120	73900600	Nut Lock Flg 3/8-16
35	120183X	Bearing Nylon Blk 629 Id	145	74490540	Bolt Hex Flghd 5/16-18 x Gr. 5
36	STD551062	Washer 21/32 x 1 x 16 Ga	150	175456	Spacer Retainer
37	STD571810	Pin Roll 3/16 x 1"	151	19133210	Washer 13/32 x 2 x 10 Ga
38	179114	Pulley Idler Composite Ext Hub	170	178394	Keeper Belt Transaxle
39	74760648	Bolt Fin Hex 3/8-16 Unc X 3	202	72110614	Bolt Carr Sh 3/8-16 x 1-3/4 Gr. 5
41	175556	Keeper Belt Idler	212	145212	Nut Hex Flange Lock
47	127783	Pulley Idler V Groove Plastic	250	17060612	Screw 3/8-16 x 3/4
48	154407	Bellcrank Clutch Grm Drv Stil			
49	123205X	Retainer Belt Style Spring			

NOTE: All component dimensions given in U. S. inches 1 inch = 25.4 mm

STEERING

TRACTOR – MODEL NUMBER 917.271552

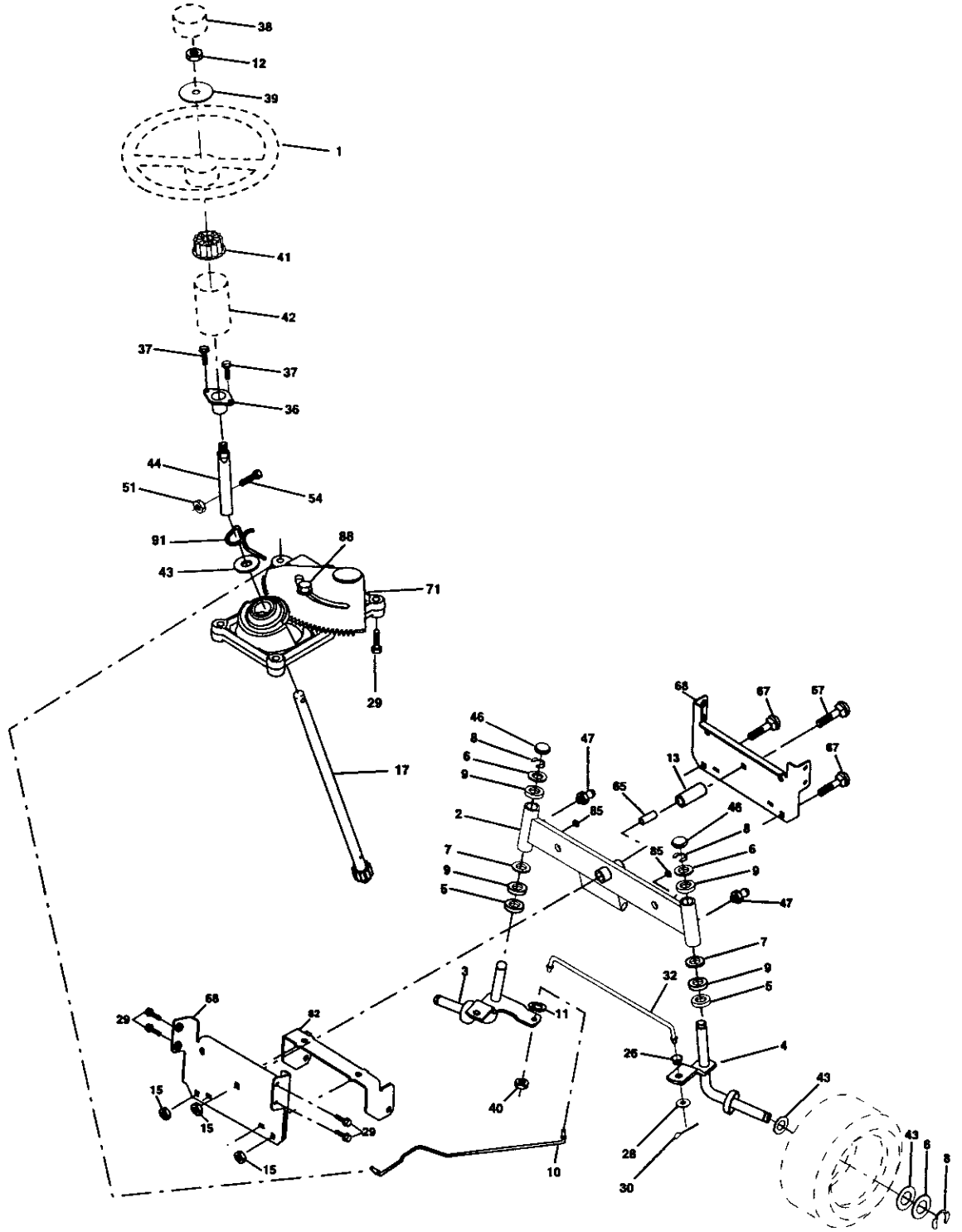

STEERING**TRACTOR – MODEL NUMBER 917.271552**

KEY NO.	PART NO.	DESCRIPTION
1	139768	Wheel Steering Opp Sears Blk
2	175131	Axle Asm Front
3	169840	Spindle Asm Lh
4	169839	Spindle Asm Rh
5	6266H	Washer Thrust .75 x 1.230
6	121748X	Washer 25/32 x 1-5/8 x 16 Ga.
7	19272016	Washer 27/32 x 1-1/4 x 16 Ga.
8	12000029	RingKlip #T5304-75
9	3366R	Bearing Col Strg Blk
10	175121	Draglink
11	10040600	Washer Lock Hvy Hlcl Spr 3/8
12	73940800	Nut Hex Jam Toplock 1/2-20 Unf
13	136518	Spacer Brg Axle Front
15	145212	Nut Hexflange Lock
17	180641	Shaft Asm Strg
26	126847X	Bushing Lnk Drag Blk LR
28	19131416	Washer 13/32 x 7/8 x 16 Ga.
29	17060612	Screw 3/8-16 x 3/4
30	STD561210	Pin Cotter 1/4 x 3/4
32	130465	Rod Tie Wire Form 19.75 Mech
36	155099	Bushing Strg. 5/8 ID Dash
37	152927	Screw
38	139769	Cap Wheel Steer Opp Sears USA
39	19183812	Washer 9/16 x 2-3/8
40	7810H	Nut Lock Center 3/8-24
41	100711L	Adaptor Wheel Strg.
42	145054X428	Boot Steering Dash P/L MTL Blk
43	121749X	Washer 25/32 x 1-1/4 x 16 Ga.
44	180640	Extension Steering Non-adjust
46	121232X	Cap Spindle Fr Top Blk
47	6855M	Fitting Grease
51	73540400	Nut Crownlock 1/4-28
54	71130420	Bolt Hex 1/4-28 Unf x 1-1/4 Gr. 8
65	160367	Spacer Axle
67	72140618	Bolt Rdhd 3/8-16 x 2-1/4
68	169827	Brace Axle
71	175146	Steering Asm
82	169835	Bracket Susp Chasis Front
85	133835	Fastner Christmas Tree
88	175118	Bolt Shoulder 7/16-20 Unc
91	175553	Clip Steering

NOTE: All component dimensions given in U. S.
inches 1 inch = 25.4 mm

TRACTOR – MODEL NUMBER 917.271552

ENGINE

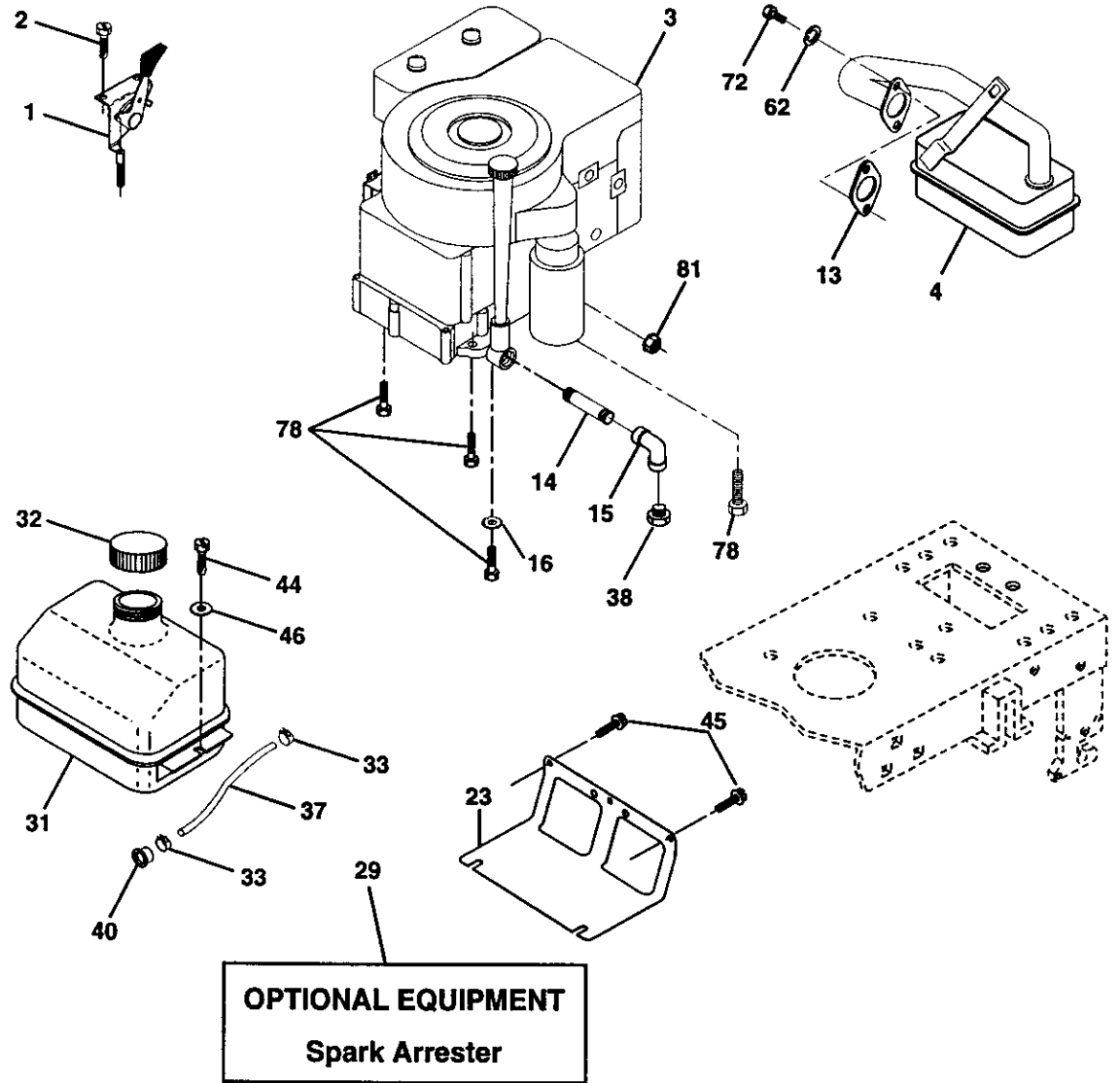

TRACTOR – MODEL NUMBER 917.271552

ENGINE

KEY PART NO.	NO.	DESCRIPTION
1	170545	Control Th/ch
2	17720408	Screw Hex Thd Cut 1/4-20 x 1/2
3	-----	Engine (See Breakdown)
4	137352	Briggs, Model No 28U707-1112-E1 Muffler Exh LT B&S 14HP IC OHV
13	165291	Gasket Eng 1 313 Id Tin Plated
14	13280324	Nipple Pipe 3/8 NPT x 3
15	13200300	Elbow Std 90 Degree 3/8-18 NPT
16	STD551237	Washer Lock Ext Tooth 3/8
23	169837	Shield Browning/Debris Guard
29	137180	Kit Spark Arrestor (Flat Scrn)
31	109202X	Tank Fuel Front 1 25
32	158990	Cap Asm Fuel Sears Vented
33	123487X	Clamp Hose Blk
37	137040	Line Fuel 20"
38	-----	Plug. drain (Order from engine mfg.)
40	124028X	Bushing Snap Nyl Blk Fuel Line
44	17670412	Screw Hexwsh Thdrol 1/4-20 x 3/4
45	17000612	Screw Hex wsh Thdr 3/8-16 x 1/4
46	19091416	Washer 9/32 x 7/8 x 16 ga
62	STD551131	Washer Lock Hvy Hlcl Spr 5/16
72	71070512	Screw Hex Hd Cap 5/16-18 X 3/4
78	17060620	Screw 3/8-16 x 1-1/4
81	73510400	Nut Keps Hex 1/4-20 Unc

NOTE: All component dimensions given in U. S.
inches 1 inch = 25.4 mm

TRACTOR – MODEL NUMBER 917.271552

SEAT ASSEMBLY

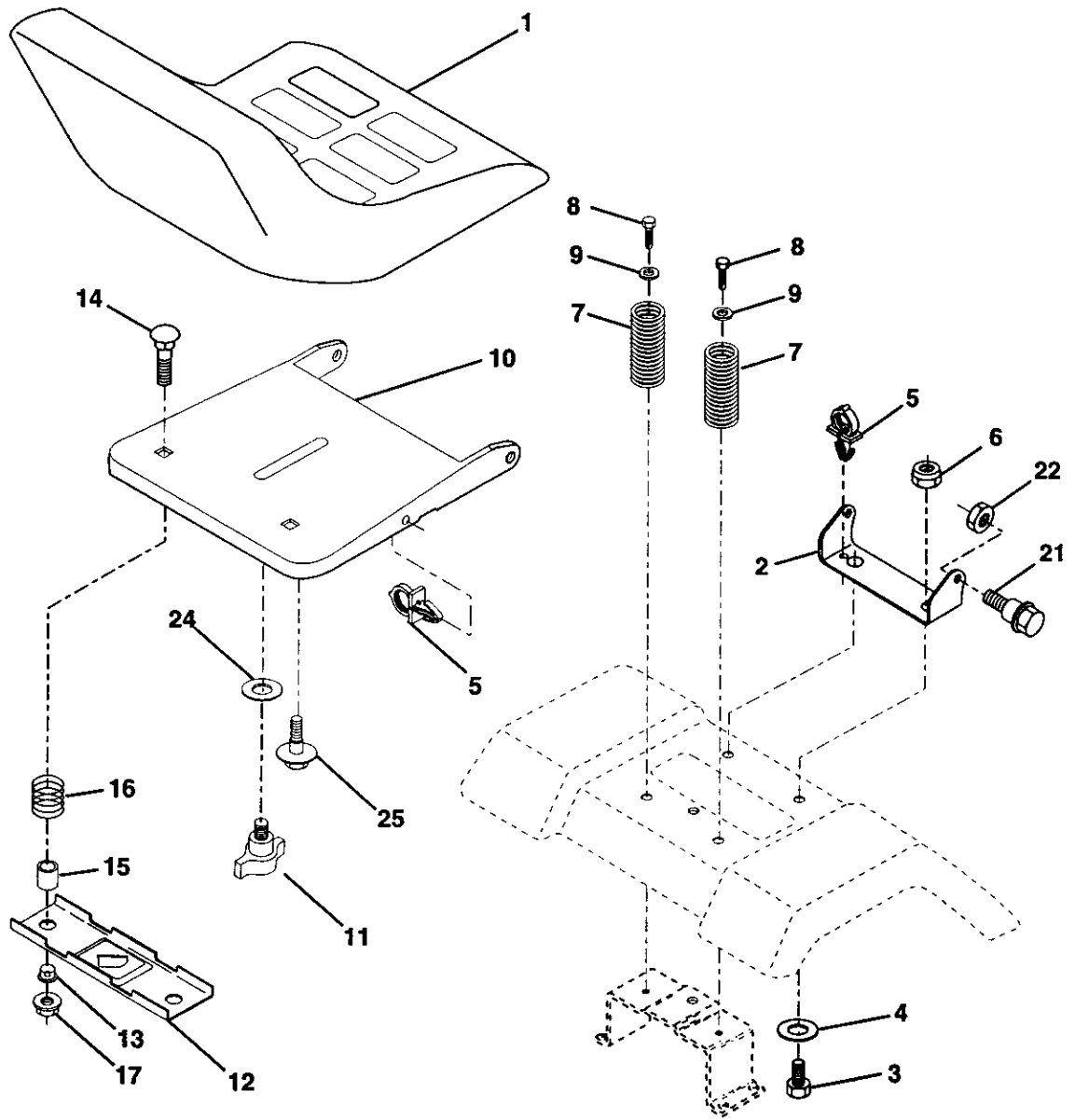

KEY PART NO.	NO.	DESCRIPTION
1	140122	Seat
2	140551	Bracket Pvt St
3	71110616	Bolt Fin Hex 3/8-16unc X 1
4	19131610	Washer Flat 13/32 X 1 X 10 Ga
5	145006	Clip Push-In Hinged
6	STD541437	Locknut Hex W/Wsh 3/8-16
7	124181X	Spring Seat Cprsn 2 250 Blk Zi
8	17000616	Screw 3/8-16 X 1-1/2
9	19131614	Washer 13/32 X 1 X 14 Ga
10	174894	Pan Seat
11	166369	Knob Seat Adj. Wingnut
12	121246X	Bracket Mounting Switch

KEY PART NO.	NO.	DESCRIPTION
13	121248X	Bushing Snap Blk Nyl 50 Id
14	72050412	Bolt Rdhd Sht Nk 1/4-20x1-1/2
15	134300	Spacer Split 28x 96 Yel Zinc
16	121250X	Spring Cprsn 1 27 Blk Pnt
17	123976X	Nut Lock 1/4 Lge Fig Gr 5 Zinc
21	171852	Bolt Shld 5/16-18 Unc-2A Blk D
22	STD541431	Nut Lock Hex *W/Ins 5/16-18
24	19171912	Washer 17/32 X 1-3/16 X 12 Ga
25	127018X	Bolt Shoulder 5/16-18 x .62

NOTE: All component dimensions given in U. S. inches 1 inch = 25.4 mm

TRACTOR -- MODEL NUMBER 917.271552

DECALS

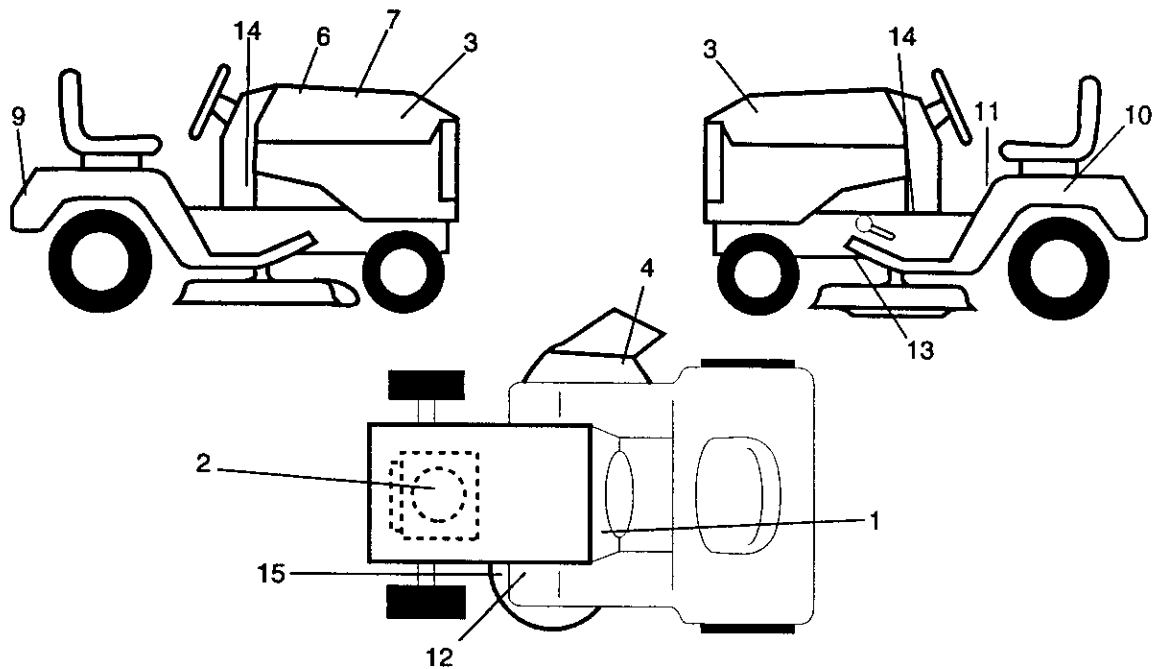

KEY PART NO.	NO.	DESCRIPTION
1	156867	Decal Dash Inst Oper English
2	181563	Decal HP Engine
3	171704	Decal Hood Logo
4	179128	Decal Deck
6	133644	Decal Maint Cust Sears Domestic
7	181412	Decal Replcmnt
9	163204	Decal Fender Craftsman White
10	149516	Decal Battery Dngr/Psn Eng Acme

KEY PART NO.	NO.	DESCRIPTION
11	156439	Decal Danger Fender Eng/span
12	181249	Decal Clutch/brake English
13	146046	Decal V-Belt Dr Sch Tractor
14	181685	Decal Panel Dash 6sp 42"
15	160396	Decal V-Belt Sch
--	179768X428	Pad Footrest LH
--	179769X428	Pad Footrest RH
--	138311	Decal Handle Lft Height Adjust
--	183208	Manual Owners English
--	183209	Manual Owners Spanish

WHEELS AND TIRES

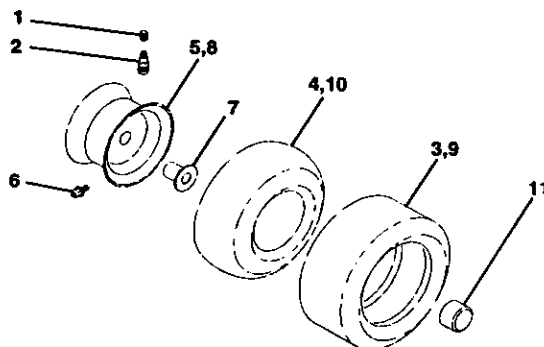

KEY PART NO.	NO.	DESCRIPTION
1	59192	Cap Valve Tire
2	65139	Stem Valve
3	106222X	Tire F Ts 15 X 6 0 - 6 Service
4	59904	Tube Inner Front #35060
5	106732X427	Rim Asm 6"front White Service
6	278H	Fitting Grease
7	9040H	Bearing Flange
8	106108X427	Rim Asm 8"rear White Service
9	124635X	Tire R Ts 18x9 5-8 Service
10	7152J	Tube Rear 9 5 X 8 Service
11	104757X428	Cap Axle Blk 1 50 X 1 00
--	144334	Sealant, Tire (10 oz. tube)

NOTE: All component dimensions given in U. S. inches 1 inch = 25.4 mm

TRACTOR – MODEL NUMBER 917.271552
LIFT ASSEMBLY

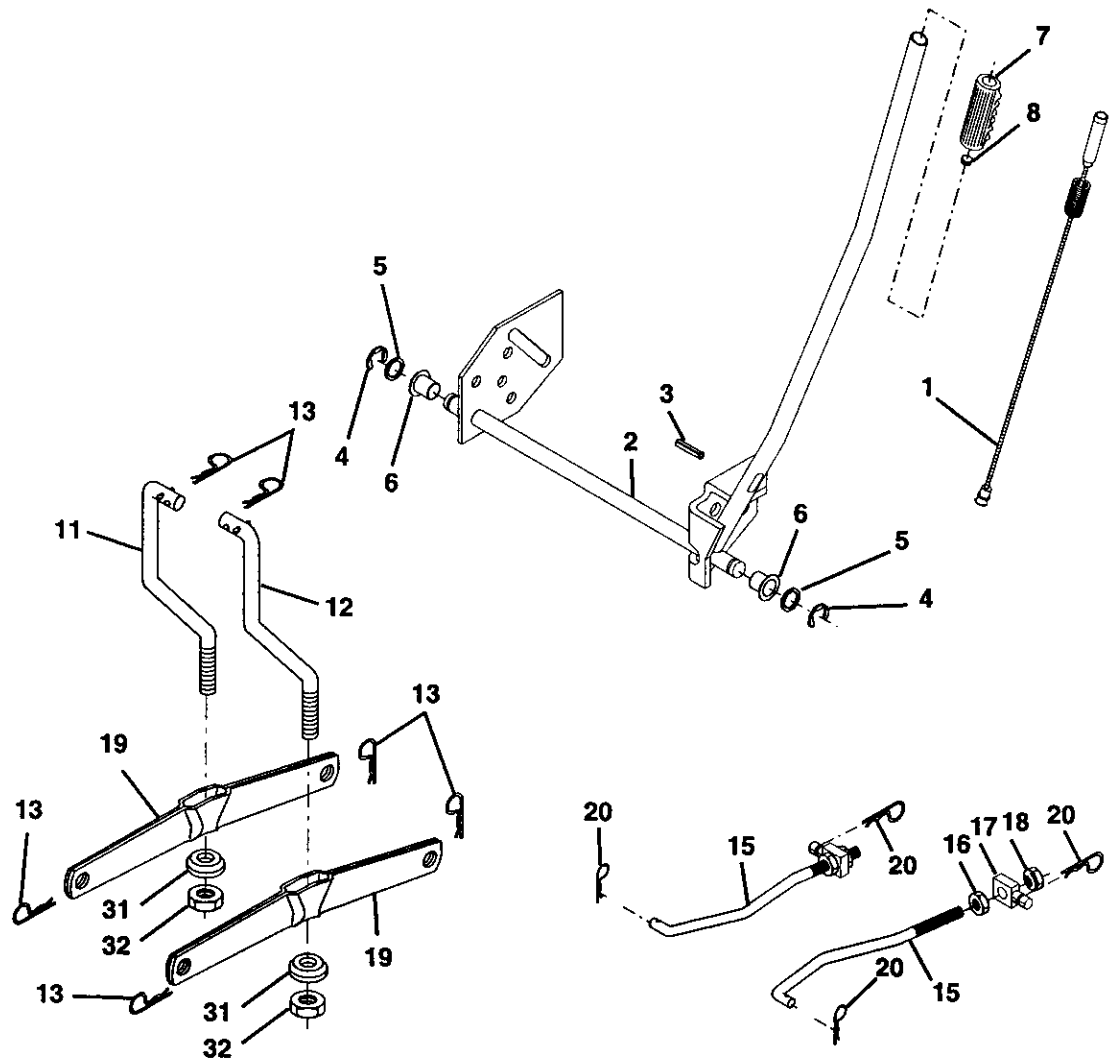

LIFT ASSEMBLY **TRACTOR – MODEL NUMBER 917.271552**

KEY PART NO.	NO.	DESCRIPTION
1	159460	Wire Asm Inner/Sprg W/plunger LT
2	159471	Shaft Asm Lift
3	105767X	Pin Groove 1 500 Zinc
4	12000002	E Ring #5133-62
5	19211621	Washer Pltd 21/32 X 1 X 21ga
6	120183X	Bearing Nylon Blk 629 Id
7	125631X	Grip Handle Fluted Blk
8	122365X	Button Plunger Red
11	139865	Link Lift LH
12	139866	Link Lift RH
13	STD624008	Retainer Spring
15	173288	Link Front
16	73350800	Nut Jam Hex 1/2-13 Unc
17	175689	Trunnion
18	73800800	Nut Lock W/Wsh 1/2-13unc
19	139868	Arm Suspension Rear
20	163552	Retainer Spring Zinc
31	169865	Bearing Pvt Lift
32	73540600	Nut Crownlock 3/8-24

NOTE: All component dimensions given in U. S. inches 1 inch = 25.4 mm

MOWER DECK

TRACTOR -- MODEL NUMBER 917.271552

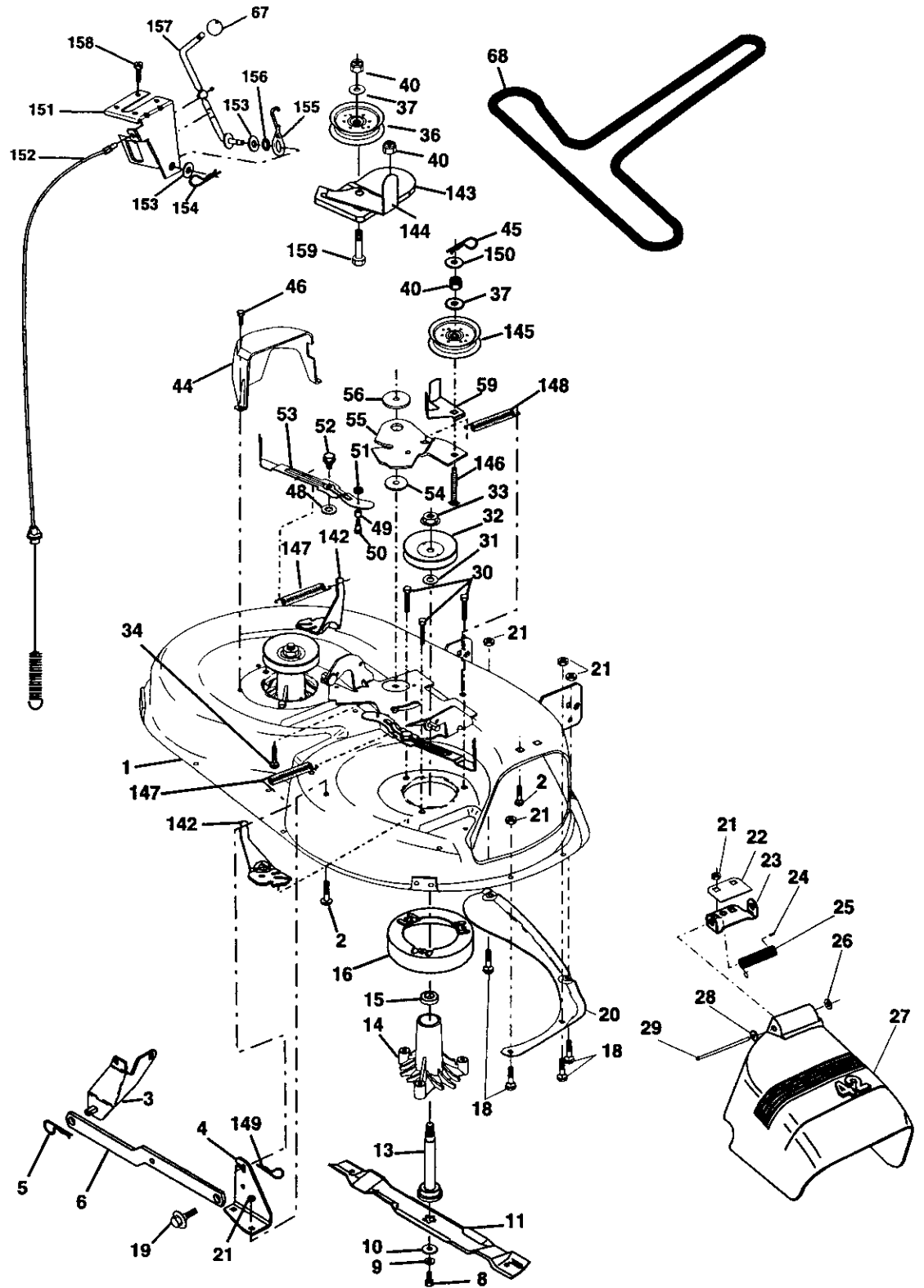

TRACTOR – MODEL NUMBER 917.271552

MOWER DECK

KEY NO.	PART NO.	DESCRIPTION	KEY NO.	PART NO.	DESCRIPTION
1	165892	Mower Deck Assembly, 42"	48	133944	Washer, Hardened
2	STD533107	Bolt	49	174284	Roller Assembly, Cam Follower
3	138017	Bracket Assembly, Sway Bar, Front	50	131340	Bolt, Shoulder #10-24 Grade 5
4	165460	Bracket Sway Bar 38/42" Deck	51	STD541410	Locknut
5	STD624008	Retainer Spring	52	139888	Bolt, Shoulder 5/16-18 UNC
6	178024	Bar Sway Deck	53	131845	Arm Assembly, Pad, Brake
8	850857	Bolt, Hex 3/8-24 x 1.25 Gr. 8	54	133943	Washer, Hardened
9	STD551137	Washer, Lock	55	155046	Arm, Idler
10	140296	Washer, Hardened	56	165723	Spacer, Retainer
11	134149	Blade, Mulching	59	141043	Guard, TUV Idler
13	180074	Shaft Assembly, Mandrel	67	149846	Knob Custom Oval
14	128774	Housing, Mandrel, Vented	68	144959	V-Belt
15	110485X	Bearing, Ball, Mandrel	142	165890	Arm Spring Brake Mower
16	174493	Stripper, Vented Mower Deck	143	157109	Bracket Arm Idler 42"
18	72140505	Bolt, Carriage 5/16-18 x 5/8	144	158634	Keeper Belt 42" Clutch Cable
19	132827	Bolt, Shoulder	145	165888	Pulley Idler Flat
20	159770	Baffle, Vortex	146	171977	Bolt Carriage Idler
21	STD541431	Nut Crownlock 5/16-18 UNC	147	131335	Spring Extension
22	134753	Stiffener Bracket	148	169022	Spring Return Idler
23	131267	Bracket, Deflector	149	165898	Retainer Spring Yellow Zinc
24	105304X	Cap, Sleeve	150	19091216	Washer 9/32 x 3/4 x 16 Ga.
25	123713X	Spring, Torsion, Deflector	151	169670	Bracket Clutch
26	110452X	Nut, Push	152	169676	Cable Clutch 42 In
27	130968X428	Shield, Deflector	153	169674	Washer Flat 3/8" Type B
28	19111016	Washer 11/32 x 5/8 x 16 Ga.	154	169675	Spring Retainer
29	131491	Rod, Hinge	155	169671	Spring Retention Lever
30	173984	Screw Hex Thd Roll	156	169672	Spacer
31	129963	Washer, Spacer	157	169669	Rod Clutch
32	153535	Pulley, Mandrel	158	17720408	Screw Thd Cut 1/4-20 x 1/2
33	178342	Nut, Toplock, Flanged	159	72140614	Bolt Rdhd Sqn 3/8-16unc x 1-3/4
34	STD533717	Bolt Rdhd 3/8-16 x 1-3/4	--	130794	Mandrel Assembly (Includes Housing, Shaft and Shaft Hardware Only - Pulley Not Included)
36	131494	Pulley, Idler, Flat			
37	STD551037	Washer 13/32 x 13/16 x 16 Gauge			
40	STD541437	Nut Crownlock 3/8-16 UNC	--	169583	Replacement Mower, Complete
44	140088	Guard, Mandrel, L.H.			
45	STD624003	Retainer			
46	137729	Screw, Thd. Roll 1/4-20 x 5/8			

NOTE: All component dimensions given in U. S. inches 1 inch = 25.4 mm

TRACTOR - MODEL NUMBER 917.271552
PEERLESS TRANSAXLE-MODEL NUMBER 206-545C

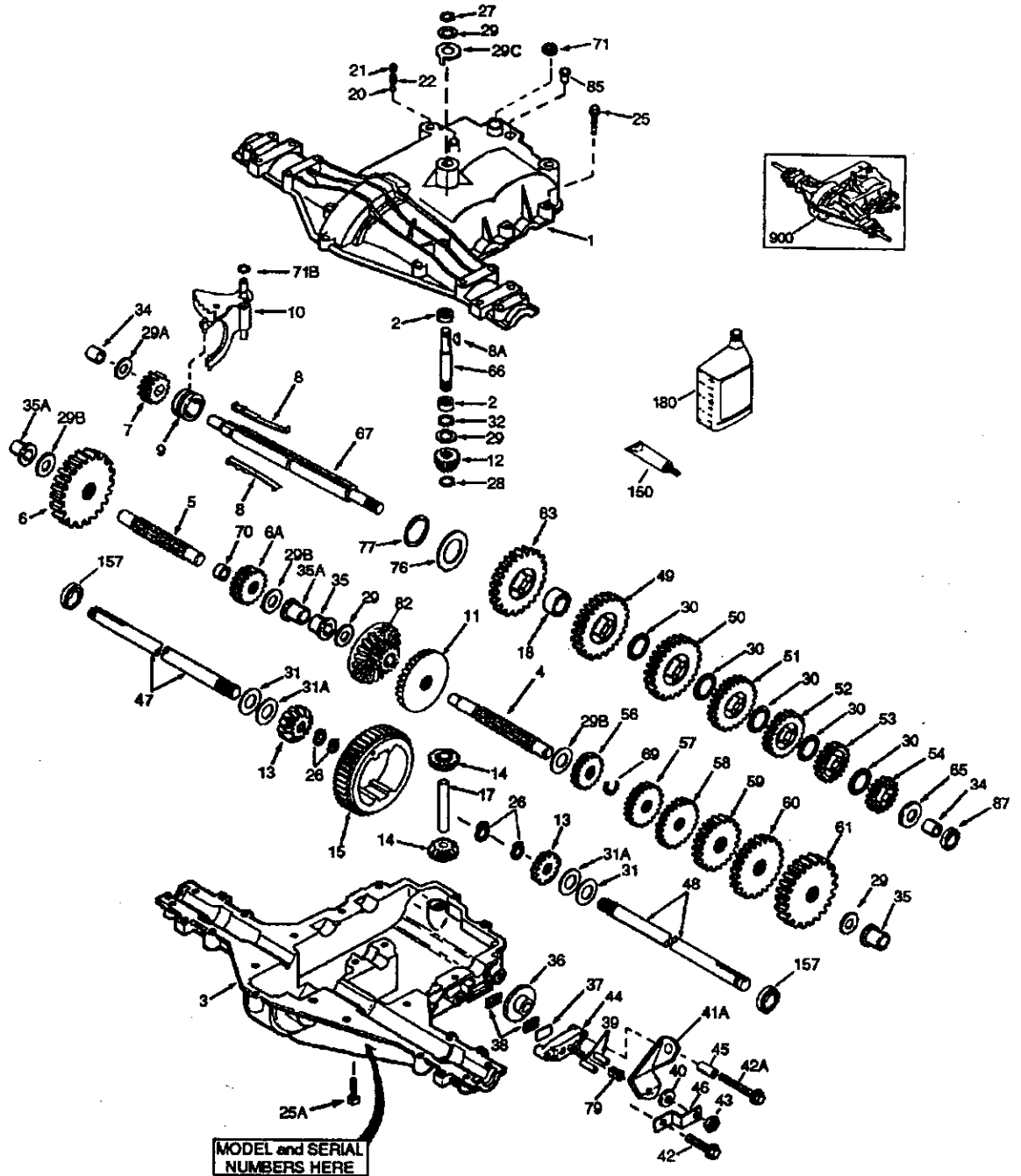

TRACTOR – MODEL NUMBER 917.271552
PEERLESS TRANSAXLE--MODEL NUMBER 206-545C

KEY NO.	PART NO.	DESCRIPTION	KEY NO.	PART NO.	DESCRIPTION
1	772147	Transaxle Cover	41A	790079	Brake Lever
2	780086A	Needle Bearing 5/8"	42	792073A	Screw 1/4 - 20 x 1-1/4"
3	770128	Transaxle Case	42A	792085A	Screw 1/4 - 20 x 2 1/4"
4	776395	Countershaft	43	792075	Locknut 5 / 16 - 24
5	776409	Output Shaft	44	790025	Brake Pad Holder
6	778364	Spur Gear (38 teeth)	45	786066	Spacer .2625 x 1.0
6A	778369	Spur Gear (15 teeth)	46	786086	Brake Lever Bracket
7	778330	Spur Gear (11 teeth)	47	774690	Axle (11-15 / 16" Long)
8	792180	Shift Key	48	774691	Axle (16 - 1 / 2" long)
8A	792047	Woodruff Key #9	49	778356	Spur Gear (29 teeth)
9	784352	Shift Collar	50	778338	Spur Gear (27 teeth)
10	784378	Shift Rod & Fork	51	778354	Spur Gear (23 teeth)
11	778334	Bevel Gear (30 teeth)	52	778352	Spur Gear (19 teeth)
12	778309	Input Bevel Pinion (13 teeth)	53	778350	Spur Gear (16 teeth)
13	778368	Bevel Gear (13 teeth) (Include. 14)	54	778346	Spur Gear (15 teeth)
14	778368	Bevel Pinion (13 teeth) (Include. 13)	56	778355	Spur Gear (11 teeth)
15	778370	Ring Gear (43 teeth)	57	778337	Spur Gear (13 teeth)
17	786188	Drive Pin	58	778353	Spur Gear (17 teeth)
18	786102	Spacer 1.130 X .695	59	778351	Spur Gear (21 teeth)
20	792077A	Ball 5/16" dia	60	778349	Spur Gear (24 teeth)
21	792078	Set Screw 3/8 - 16 x 3/8"	61	778345	Spur Gear (25 teeth)
22	792079	Spring .310 OD x .625 L	65	780189	Flat Washer .563 ID x .062W
25	792073A	Screw 1/4 - 20 x 1-1/4"	66	776422	Input Shaft
25A	792177	Screw 1/4-20 x 1-3/8"	67	776396	Shifter & Brake Shaft
26	792125	Retaining Ring (pkg of 2)	69	792170	Retaining Ring
27	792035	Retaining Ring	70	786187	Spacer .890
28	788040	Retaining Ring	71	788069	Square Cut Ring
29	780072	Thrust Washer .627 ID x .031W	71B	788092	"O" Ring
29A	780160	Thrust Washer .762 ID x .031W	76	780090	Flat Washer 1.128 ID x .058W
29B	780051	Thrust Washer .762 ID x .031W	77	788078A	Inverted Retaining Ring
29C	780199	Anti-Rotation Washer .632	79	792144	Spring .430 OD x .5000 L
30	780108	Cup Washer 1.127 ID x .032W	82	778333	Bevel & Spur Gear (30 & 13 teeth)
31	780001	Flat Washer .750 ID x .056W (Use As Needed)	83	778338	Spur Gear (27 teeth)
31A	780195	Flat Washer .750 ID x .062W	85	792154	Oil Fill Plug
32	788083	Oil Seal 5/8"	87	788089A	Oil Seal 9 / 16"
34	780194	Bushing .563	150	788093A	Liquid Gasket RTV Silicone
35	780193	Flanged Bushing 5 / 8" ID	157	788088A	Oil Seal 3 / 4"
35A	780197	Flanged Bushing .751	180	730229A	Gear Oil 80W90
36	790075	Brake Disk	900	794712	Replacement MST - 206-545C Transaxle
37	790007	Brake Pad Plate			
38	799021	Brake Pad (pkg of 2)			
39	786026	Dowel Pin			
40	792076A	Flat Washer .312 ID x .059W			

NOTE: All component dimensions given in U.S. inches 1 inch = 25.4 mm

**TRACTOR – MODEL NUMBER 917.271552
BRIGGS & STRATTON ENGINE-MODEL NUMBER 28U707, TYPE NUMBER 1112-E1**

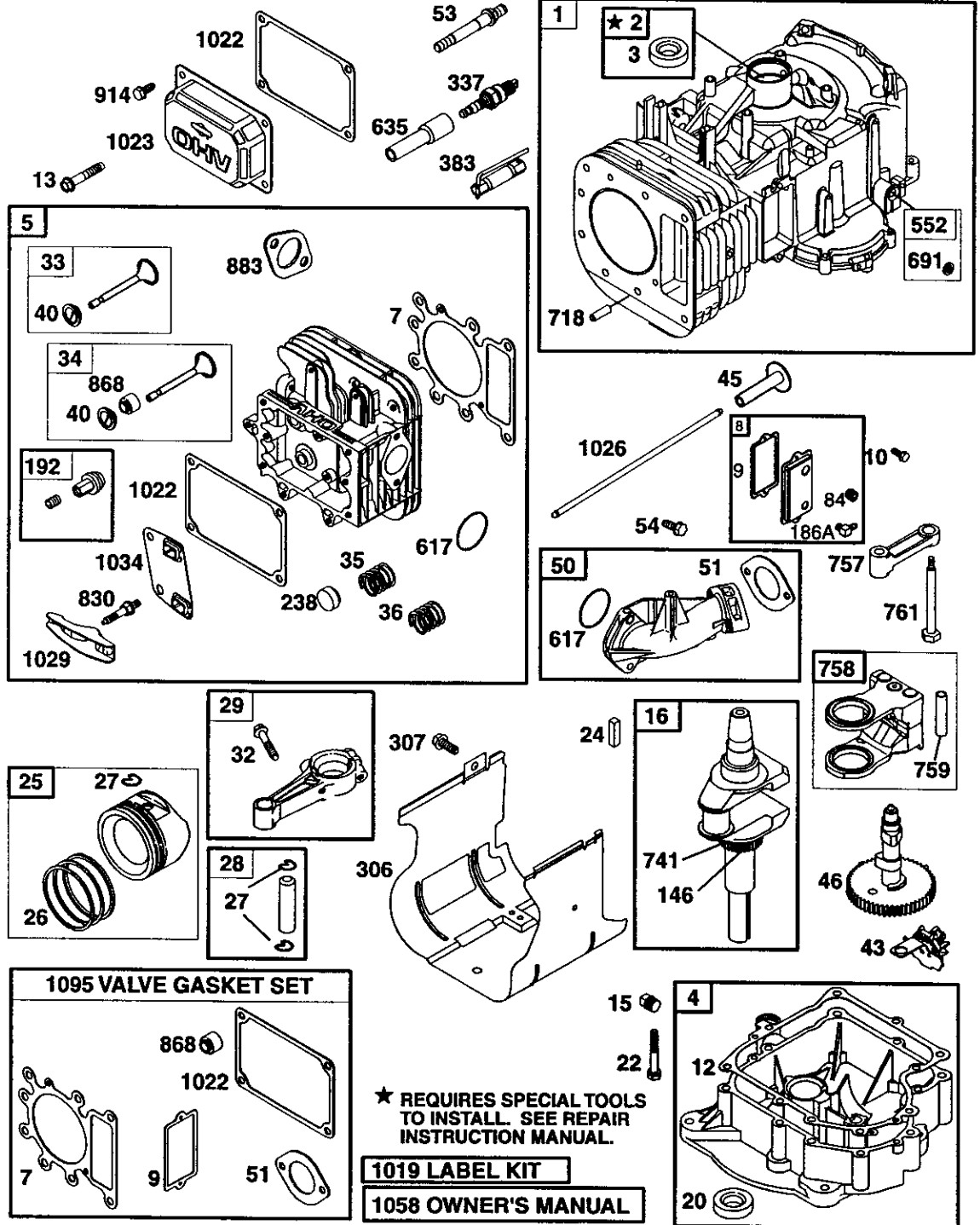

**TRACTOR – MODEL NUMBER 917.271552
BRIGGS & STRATTON ENGINE-MODEL NUMBER 28U707, TYPE NUMBER 1112-E1**

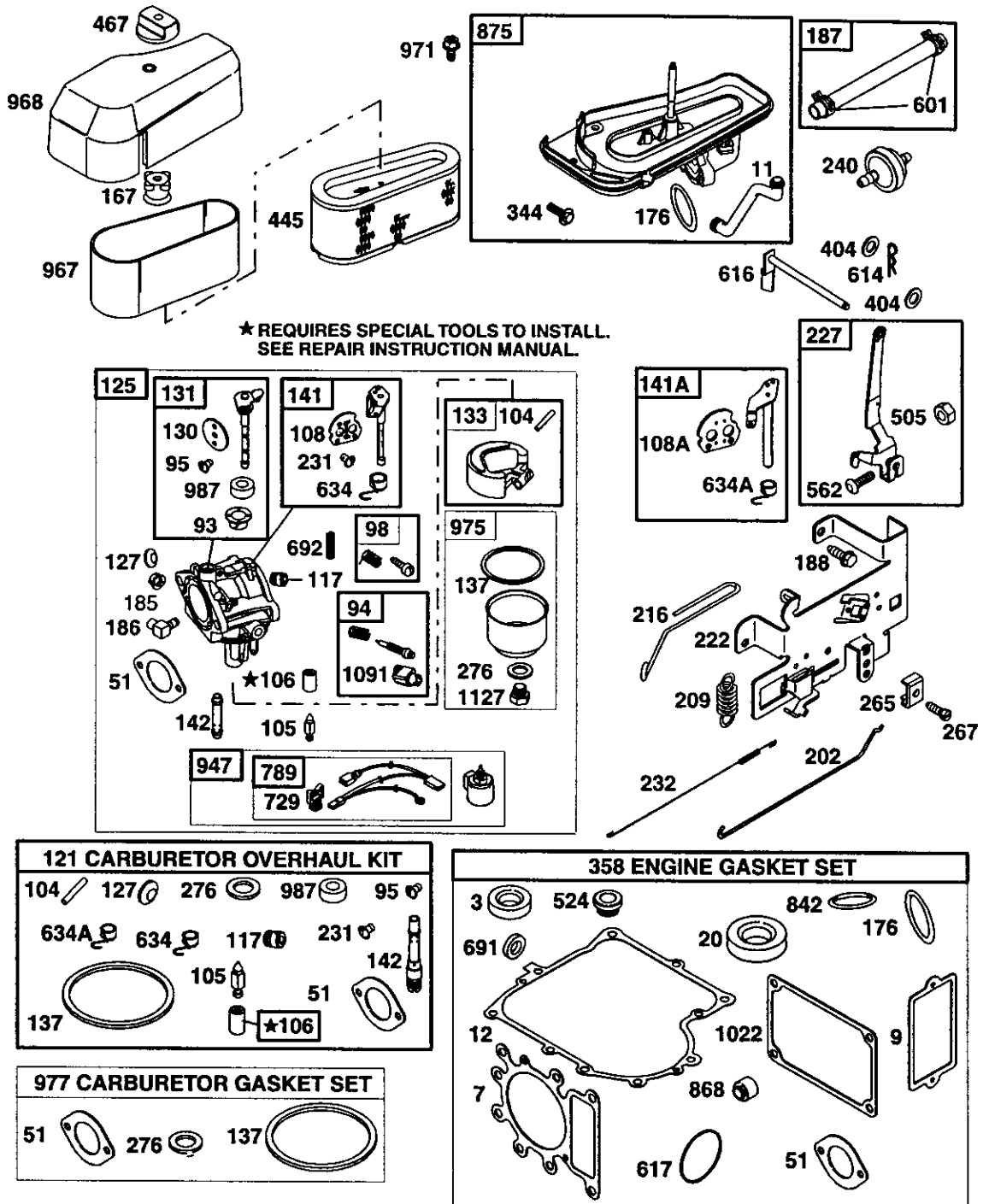

TRACTOR – MODEL NUMBER 917.271552
BRIGGS & STRATTON ENGINE-MODEL NUMBER 28U707, TYPE NUMBER 1112-E1

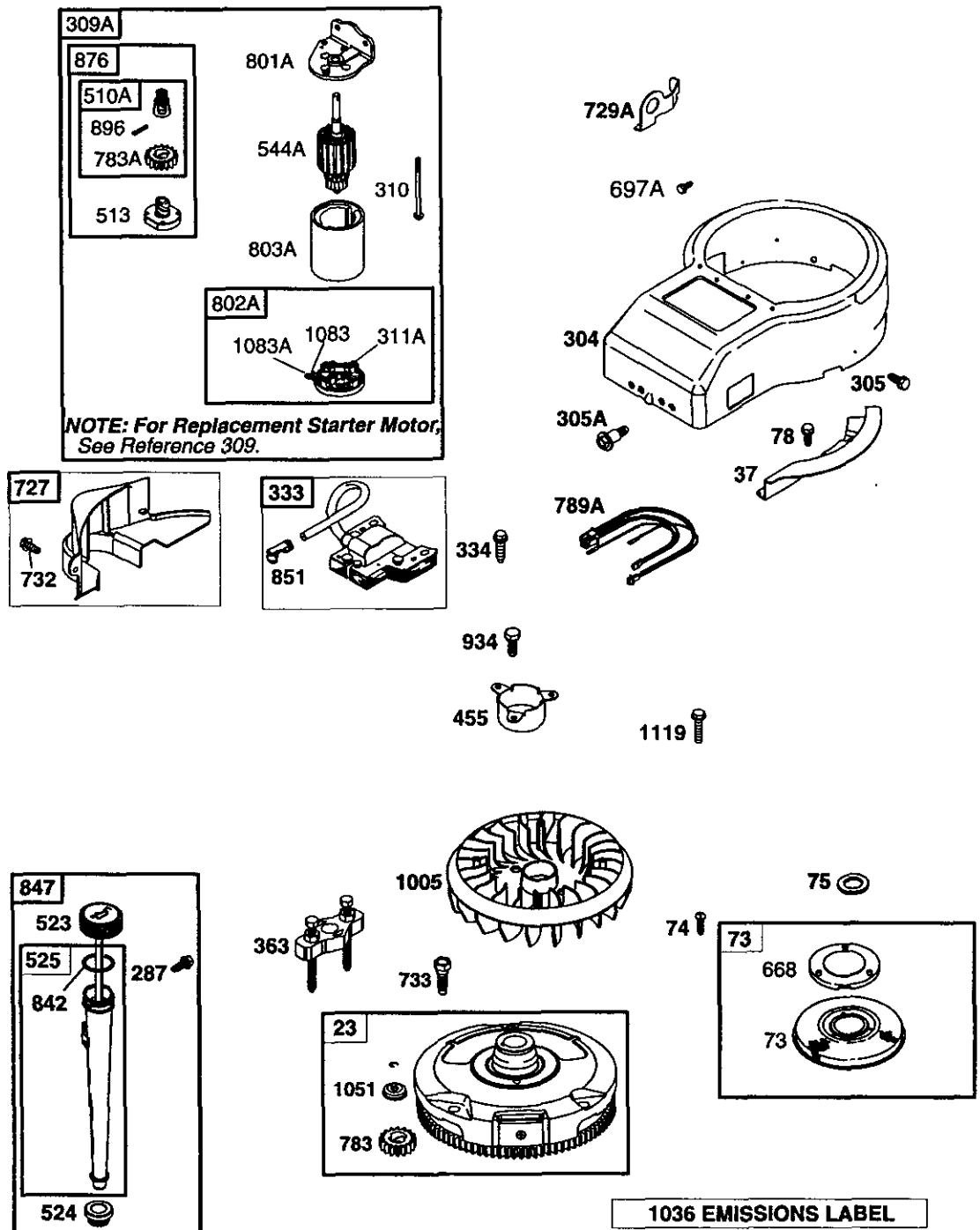

**TRACTOR – MODEL NUMBER 917.271552
BRIGGS & STRATTON ENGINE-MODEL NUMBER 28U707, TYPE NUMBER 1112-E1**

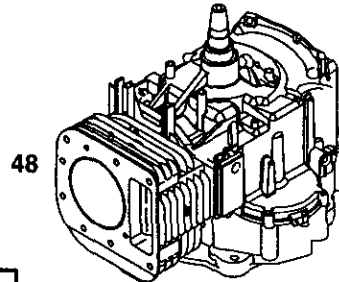

NIKKI

125A	141B
131A	108B
130A	231A
95A	633
987A	
217	133A
127A	104A
98A	975A
94A	137A
51	369
105A	1127A
117A	276A
	947A

121A CARBURETOR OVERHAUL KIT			
51	95A	276A	
	104A	127A	117A
	105A	987A	
137A		231A	

977A CARBURETOR GASKET SET		
51	137A	276A

TRACTOR – MODEL NUMBER 917.271552
BRIGGS & STRATTON ENGINE-MODEL NUMBER 28U707, TYPE NUMBER 1112-E1

KEY NO.	PART NO.	DESCRIPTION	KEY NO.	PART NO.	DESCRIPTION
1	496412	Cylinder Assembly	29	692419	Rod-Connecting (Standard)
2	399265	Kit-Bushing/Seal		692420	Rod-Connecting (.020 Undersize)
3	391086	• Seal-Oil (Magneto Side)	32	692852	Screw (Connecting Rod)
4	494238	Sump-Engine	33	495856	Valve-Exhaust
5	691165	Head-Cylinder	34	495857	Valve-Intake
7	273280	*+ Gasket-Cylinder Head	35	691279	Spring-Valve (Intake)
8	696126	Breather Assembly	36	691279	Spring-Valve (Exhaust)
9	27803	• Gasket-Breather	37	690456	Guard-Flywheel
10	691666	Screw (Breather Assembly)	40	691752	Retainer-Valve
11	691328	Tube-Breather	43	691968	Slinger-Governor/Oil
12	692226	• Gasket-Crankcase (.015 Thick, Std.)	45	690564	Tappet-Valve
	692406	• Gasket-Crankcase (.005 Thick)	46	692421	Camshaft
	692405	• Gasket-Crankcase (.009 Thick)	48	496050	Short Block (Replacement Engine 311707-0026-E1)
13	690360	Screw (Cylinder Head)	50	690193	Manifold-Intake
15	690946	Plug-Oil Drain	51	692137*Ø‡	Gasket-Intake
16	690136	Crankshaft	53	690227	Stud (Carburetor)
20	291675	• Seal-Oil (PTO Side)	54	691148	Screw (Intake Manifold)
22	692125	Screw (Engine Sump)	73	690492	Screen-Rotating
23	693557	Flywheel (Steel Ring Gear)	74	691155	Screw (Rotating Screen)
24	222698	Key-Flywheel	75	690582	Washer (Flywheel)
25	696397	Piston Assembly (Standard) (Used After Date Code 01041800)	78	690661	Screw (Flywheel Guard)
			84	690343	Plug-Breather
25	696398	Piston Assembly (.010" Oversize) (Used After Date Code 01041800)	93	690602	Bushing-Throttle Shaft
			94	498030	Idle Mixture Kit
25	696399	Piston Assembly (.020" Oversize) (Used After Date Code 01041800)	94A	695425	Idle Mixture Kit
			95	691636	Ø Screw (Throttle Valve)
25	696400	Piston Assembly (.030" Oversize) (Used After Date Code 01041800)	95A	690718	Ø Screw (Throttle Valve)
			98	495800	Idle Speed Kit
25	499284	Piston Assembly (Standard) (Used Before Date Code 01041900)	98A	695408	Idle Speed Kit
			104	690525	Ø Pin-Float Hinge
25	499288	Piston Assembly (.010" Oversize) (Used Before Date Code 01041900)	104A	694918	Ø Pin-Float Hinge
			105	231855	Ø Valve-Float Needle
25	499292	Piston Assembly (.020" Oversize) (Used Before Date Code 01041900)	105A	694922	Ø Valve-Float Needle
			106	690577	Ø Seat-Inlet
25	499296	Piston Assembly (.030" Oversize) (Used Before Date Code 01041900)	108	690464	Valve-Choke (Manual Choke)
			108A	692344	Valve-Choke (Choke A Matic)
26	696403	Ring Set (Standard) (Used After Date Code 01041800)	108B	695419	Valve-Choke
			117	692408	Ø Jet-Main (Standard)
26	696404	Ring Set (.010" Oversize) (Used After Date Code 01041800)		692411	Jet-Main (High Altitude)
			117A	695415	Ø Jet-Main (Standard)
26	696405	Ring Set (.020" Oversize) (Used After Date Code 01041800)		695416	Ø Jet-Main (High Altitude)
			121	690191	Kit-Carburetor Overhaul
26	696406	Ring Set (.030" Oversize) (Used After Date Code 01041800)	121A	695427	Kit-Carburetor Overhaul
			125	690194	Carburetor
26	495854	Ring Set-Piston (Standard) (Used Before Date Code 01041900)	125A		Carburetor (Nikki) (Service with Walbro Carburetor only)
			127	695005	Ø Plug-Welch
26	495852	Ring Set-Piston (.010 Oversize) (Used Before Date Code 01041900)	127A	690727	Ø Plug-Welch
			130	691750	Valve-Throttle
26	495851	Ring Set-Piston (.020 Oversize) (Used Before Date Code 01041900)	130A	695418	Valve-Throttle
			131	494379	Throttle Shaft Kit
26	495855	Ring Set-Piston (.030 Oversize) (Used Before Date Code 01041900)	131A	695421	Throttle Shaft Kit
			133	494381	Float-Carburetor
27	691299	Lock-Piston Pin	133A	694914	Float-Carburetor
28	498319	Pin-Piston (Standard)	137	281165	Ø‡ Gasket-Float Bowl
	498320	Pin-Piston (.005 Oversize)	137A	695426	Ø‡ Gasket-Float Bowl
			141	495097	Choke Shaft Kit (Manual Choke)
			141A	495931	Choke Shaft Kit (Choke A Matic)
			141B	695420	Choke Shaft Kit
			142	692412	Ø Nozzle-Carburetor
			146	691639	Key-Timing
			167	692297	Nut (Air Cleaner)
			176	691917	• O-Ring Seal (Air Cleaner Base)
			185	690958	Nut (Air Cleaner Base)
			186	692317	Connector-Hose
			186A	691609	Connector-Hose
			187	691050	Line-Fuel (Cut to Required Length)

TRACTOR – MODEL NUMBER 917.271552
BRIGGS & STRATTON ENGINE-MODEL NUMBER 28U707, TYPE NUMBER 1112-E1

KEY NO.	PART NO.	DESCRIPTION	KEY NO.	PART NO.	DESCRIPTION
188	691693	Screw (Control Bracket)	729A	691224	Clip-Wire
192	691986	Adjuster-Rocker Arm	732	691002	Screw (Starter Drive Cover)
202	691841	Link-Mechanical Governor	733	691658	Screw (Flywheel)
209	692208	Spring-Governor	741	691284	Gear-Timing
216	691840	Link-Choke	757	691714	Link-Counterweight
217	695409	Spring-Choke Return	758	692423	Counterweight
222	694042	Bracket-Control	759	691239	Pin-Counterweight
227	691374	Control Lever-Governor	761	691096	Screw (Counterweight)
231	691636	Ø Screw (Choke Valve)	783	693713	Gear-Pinion
231A	690718	Ø Screw (Choke Valve)	783A	693059	Gear-Pinion (Aluminum)
232	691842	Spring-Governor Link	789	692037	Harness-Wiring
238	691843	Cap-Valve	789A	695050	Harness-Wiring
240	394358	Filter-Fuel	797	693167	Nut (Brush Retainer)
265	691024	Clamp-Casing	801	691283	Cap-Drive
267	695134	Screw (Casing Clamp)	801A	394856	Cap-Drive
276	692255	Ø‡ Sealing Washer	802	691286	Cap-End
276A	695410	Ø‡ Sealing Washer	802A	395537	Cap-End
287	691002	Screw (Dipstick Tube)	803	693757	Housing-Starter
304	690844	Housing-Blower	803A	398159	Housing-Starter
305	690960	Screw (Blower Housing)	830	691095	Stud (Rocker Arm)
305A	692127	Screw (Blower Housing)	842	691870	• Dipstick/Tube Seal
306	690499	Shield-Cylinder	847	496415	Dipstick/Tube Assembly
307	691003	Screw (Cylinder Shield)	851	692424	Terminal-Spark Plug
309	693551	Motor-Starter	868	690968	•+ Seal-Valve
309A		Motor-Starter (For Replacement Starter Motor, See Reference 309)	875	694942	Base-Air Cleaner
			877	393456	Wire-Connector/Alternator
			883	692236	Gasket-Exhaust
310	690323	Bolt (Starter Motor)	896	691641	Pin-Drive Retainer
311	497608	Brush Set	914	690960	Screw (Rocker Cover)
311A	395538	Brush Set	934	691058	Screw (Fan Retainer)
333	495859	Armature-Magneto	947	497672	Solenoid-Fuel
334	691061	Screw (Armature Magneto)	947A	695423	Solenoid-Fuel
337	491055	Spark Plug	967	272403	Filter-Pre Cleaner
344	693675	Screw (Cable Clamp)	968	691916	Cover-Air Cleaner
358	691580	Engine Gasket Set	971	692129	Screw (Air Cleaner Base)
363	19203	Flywheel Puller	975	495933	Bowl-Float
369	695422	Spring-Float Bowl	975A	695417	Bowl-Float
383	89838	Wrench-Spark Plug	977	690192	Gasket Set-Carburetor
404	691691	Washer (Governor Crank)	977A	695428	Gasket Set-Carburetor
445	496894	Filter-Air Cleaner Cartridge	987	691326	Ø Seal-Throttle Shaft
455	691173	Cup-Flywheel	987A	690998	Ø Seal-Throttle Shaft
462	691261	Washer (Starter Cable)	996	690678	Shield-Carburetor
467	691668	Knob-Air Cleaner	1005	695056	Fan-Flywheel
474	696459	Alternator	1019	496758	Kit-Label
503	691532	Strap-Starter	1022	272475	•+ Gasket-Rocker Cover
505	691251	Nut (Governor Control Lever)	1023	691192	Cover-Rocker Arm
510	693699	Drive-Starter	1026	692003	Rod-Push (Intake)
510A	495878	Drive-Starter	1026	692011	Rod-Push (Exhaust)
513	692024	Clutch-Drive	1029	691751	Arm-Rocker
523	692014	Dipstick	1034	690822	Guide-Push Rod
524	281370	• Seal-Dipstick Tube	1036	695700	Label-Emissions
525	691398	Tube-Dipstick	1051	691265	Ring-Retainer
544	692034	Armature-Starter	1058	274789	Owner's Manual
544A	390837	Armature-Starter	1083	691626	Nut (Starter Terminal)
552	491986	Bushing-Governor Lever	1083A	690958	Nut (Starter Terminal)
562	691119	Bolt (Governor Control Lever)	1090	691293	Retainer-Brush
579	691029	Nut (Starter Cable)	1091	691333	Cap-Limiter
601	95162	Clamp-Hose	1095	691581	Valve Gasket Set
614	691620	Pin-Cotter	1119	691183	Screw (Alternator)
616	692012	Crank-Governor	1127	691657	Screw (Float Bowl)
617	692138	• O-Ring Seal (Intake Manifold)	1127A	695427	Screw (Float Bowl)
633	695414	Seal-Choke/Throttle Shaft			RPM Settings:
634	690801	Ø Seal/Spring Assembly (Manual Choke)			Low Speed: 1900-2100
					High Speed: 3000-3200
634A	690802	Ø Seal/Spring Assembly (Choke A Matic)			• Included in Engine Gasket Set, Key. No. 358
635	691909	Boot-Spark Plug			Ø Included in Carburetor Overhaul Kit, Key. No. 121 and 121A
668	691323	Spacer			‡ Included in Carburetor Gasket Set, Key. No. 977 and 977A
691	692407	• Governor Shaft Seal			+ Included in Valve Gasket Set, Key. No. 1095
692	690572	Spring-Detent			
697	690372	Screw (Starter Motor)			
718	690959	Pin-Locating			
727	490324	Cover-Starter Drive			
729	691335	Clip-Wire			

SERVICE NOTES

SERVICE NOTES

SERVICE NOTES

SUGGESTED GUIDE FOR SIGHTING SLOPES FOR SAFE OPERATION

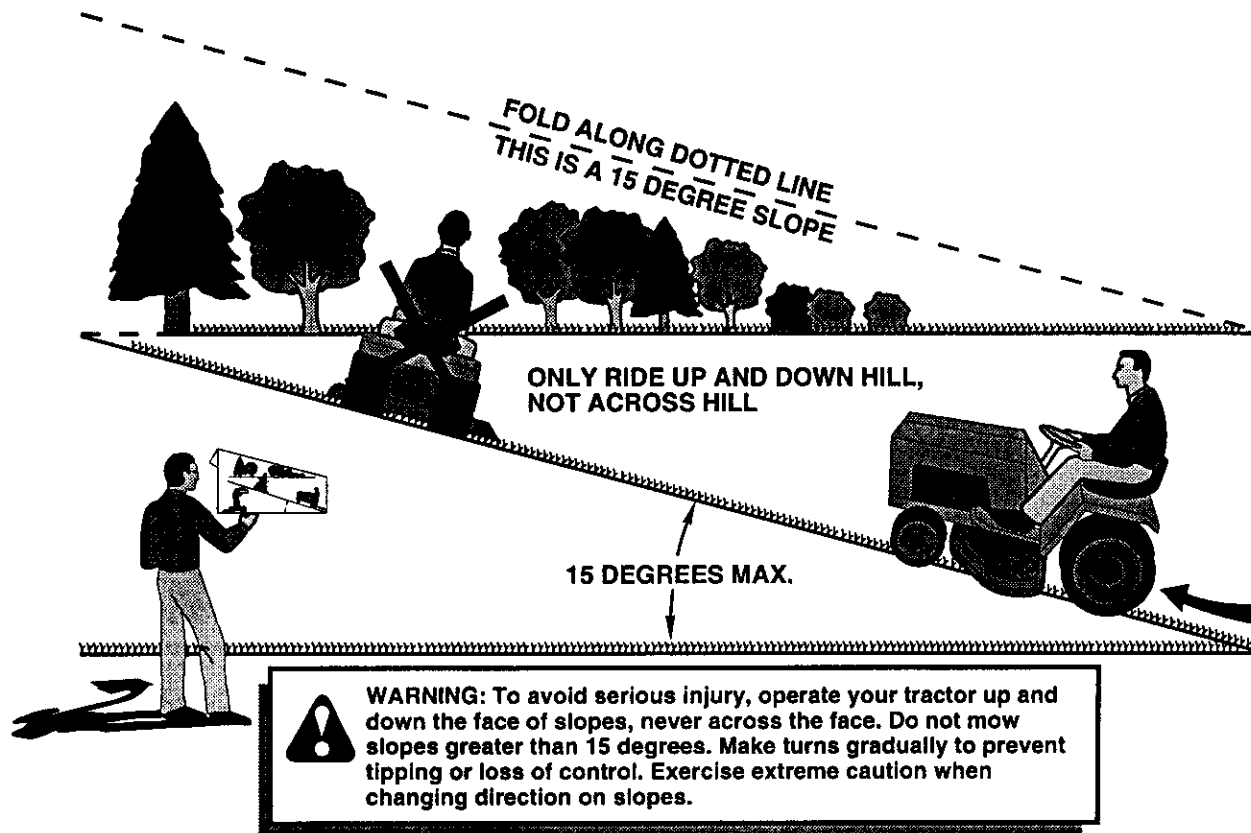

1. Fold this page along dotted line indicated above.
2. Hold page before you so that its left edge is vertically parallel to a tree trunk or other upright structure.
3. Sight across the fold in the direction of hill slope you want to measure.
4. Compare the angle of the fold with the slope of the hill.

Get it fixed, at your home or ours!

For repair of major brand appliances in your own home . . .
no matter who made it, no matter who sold it!

1-800-4-MY-HOME® Anytime, day or night
(1-800-469-4663) (U.S.A. and Canada)
www.sears.com www.sears.ca

For repair of carry-in products like vacuums, lawn equipment, and
electronics, call for the nearest **Sears Parts and Repair Center.**

1-800-488-1222 Anytime, day or night (U.S.A. only)
www.sears.com

For the replacement parts, accessories and owner's manuals
that you need to do-it-yourself, call **Sears PartsDirectSM**!

1-800-366-PART 6 a.m. – 11 p.m., 7 days a week
(1-800-366-7278) (U.S.A. only)
www.sears.com/partsdirect

To purchase or inquire about a Sears Service Agreement
or Sears Maintenance Agreement:

1-800-827-6655 (U.S.A.) **1-800-361-6665** (Canada)
7 a.m. – 5 p.m., CST, Mon. – Sat. 9 a.m. – 8 p.m. EST, M – F, 4 p.m. Sat.

Para pedir servicio de reparación a
domicilio, y para ordenar piezas:
1-888-SU-HOGARSM
(1-888-784-6427)

Au Canada pour service en français:
1-800-LE-FOYER^{MC}
(1-800-533-6937)
www.sears.ca

SEARS
HomeCentral®

© Sears, Roebuck and Co.

® Registered Trademark / TM Trademark / SM Service Mark of Sears, Roebuck and Co.

® Marca Registrada / TM Marca de Fábrica / SM Marca de Servicio de Sears, Roebuck and Co.

^{MC} Marque de commerce / ^{MD} Marque déposée de Sears, Roebuck and Co.