

# PRO-FORM 590 LS CROSSWALK

Model No. 831.299620

Serial No. \_\_\_\_\_

Write the serial number in the space above for future reference.

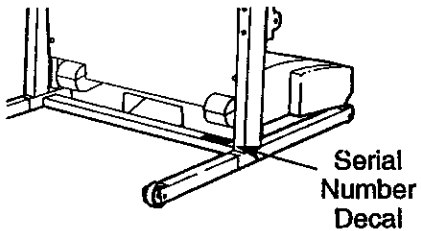

EXERCISE  
EQUIPMENT

QUESTIONS

HELPLINE!

1-800-736-6879

SEARS, ROEBUCK AND CO.  
HOFFMAN ESTATES, IL 60179

## CAUTION

Read all precautions and instructions in this manual before using this equipment. Save this manual for future reference.

## USER'S MANUAL

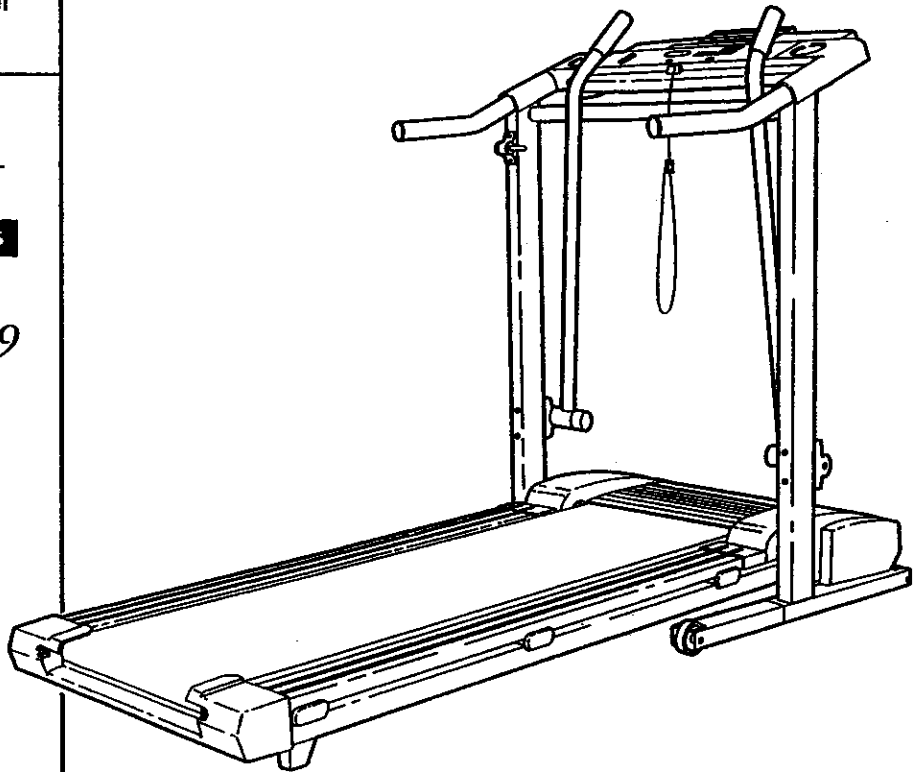

Visit our website at

[www.proform.com](http://www.proform.com)

*new products, prizes,  
fitness tips, and much more!*

# TABLE OF CONTENTS

IMPORTANT PRECAUTIONS	2
BEFORE YOU BEGIN	4
ASSEMBLY	5
OPERATION AND ADJUSTMENT	7
HOW TO FOLD AND MOVE THE TREADMILL	10
TROUBLE-SHOOTING	12
CONDITIONING GUIDELINES	14
ORDERING REPLACEMENT PARTS	Back Cover
FULL 90-DAY WARRANTY	Back Cover

Note: An EXPLODED DRAWING is attached in the center of this manual.

## IMPORTANT PRECAUTIONS

**⚠ WARNING:** To reduce the risk of burns, fire, electric shock, or injury to persons, read the following important precautions and information before operating the treadmill.

1. It is the responsibility of the owner to ensure that all users of this treadmill are adequately informed of all warnings and precautions.
2. Use the treadmill only as described.
3. Place the treadmill on a level surface, with eight feet of clearance behind it. Do not place the treadmill on a surface that blocks any air openings. To protect the floor or carpet from damage, place a mat under the treadmill.
4. Keep the treadmill indoors, away from moisture and dust. Do not put the treadmill in a garage or covered patio, or near water.
5. Do not operate the treadmill where aerosol products are used or where oxygen is being administered.
6. Keep children under the age of 12 and pets away from the treadmill at all times.
7. The treadmill should be used only by persons weighing 250 pounds or less.
8. Never allow more than one person on the treadmill at a time.
9. Wear appropriate exercise clothing when using the treadmill. Do not wear loose clothing that could become caught in the treadmill. Athletic support clothes are recommended for both men and women. Always wear athletic shoes. Never use the treadmill with bare feet, wearing only stockings, or in sandals.
10. When connecting the power cord (see page 7), plug the power cord into a surge suppressor (not included) and plug the surge suppressor into a grounded circuit capable of carrying 15 or more amps. No other appliance should be on the same circuit. Do not use an extension cord.
11. Use only a single-outlet surge suppressor that meets all of the specifications described on page 7. To purchase a surge suppressor, see your local SEARS or call 1-800-368-7278 and order part number 146148.
12. Failure to use a properly functioning surge suppressor could result in damage to the control system of the treadmill. If the control system is damaged, the walking belt may change speed or stop unexpectedly, which may result in a fall and serious injury.
13. Keep the power cord and the surge suppressor away from heated surfaces.
14. Never move the walking belt while the power is turned off. Do not operate the treadmill if the power cord or plug is damaged, or if the treadmill is not working properly. (See BEFORE YOU BEGIN on page 4 if the treadmill is not working properly.)
15. Never start the treadmill while you are standing on the walking belt. Always hold the handrails or upper body arms while using the treadmill.

16. The treadmill is capable of high speeds. Adjust the speed in small increments to avoid sudden jumps in speed.

17. The pulse sensor is not a medical device. Various factors, including the user's movement, may affect the accuracy of heart rate readings. The pulse sensor is intended only as an exercise aid in determining heart rate trends in general.

18. Never leave the treadmill unattended while it is running. Always remove the key and unplug the power cord when the treadmill is not in use.

19. Do not attempt to raise, lower, or move the treadmill until it is properly assembled. (See ASSEMBLY on page 5, and HOW TO FOLD AND MOVE THE TREADMILL on page 10.) You must be able to safely lift 45 pounds (20 kg) to raise, lower, or move the treadmill.

20. When folding or moving the treadmill, make sure that the storage latch is fully closed.

21. Inspect and tighten all parts of the treadmill every three months.

22. Never drop or insert any object into any opening.

23. **DANGER:** Always unplug the power cord immediately after use, before cleaning the treadmill, and before performing the maintenance and adjustment procedures described in this manual. Never remove the motor hood unless instructed to do so by an authorized service representative. Servicing other than the procedures in this manual should be performed by an authorized service representative only.

24. This treadmill is intended for in-home use only. Do not use this treadmill in any commercial, rental, or institutional setting.

**WARNING:** Before beginning this or any exercise program, consult your physician. This is especially important for persons over the age of 35 or persons with pre-existing health problems. Read all instructions before using. SEARS assumes no responsibility for personal injury or property damage sustained by or through the use of this product.

## SAVE THESE INSTRUCTIONS

The decals shown below have been placed on your treadmill. If a decal is missing, or if it is not legible, please call our toll-free HELPLINE to order a free replacement decal (see the front cover of this manual). Apply the decal in the location shown.

**WARNING!** Protect yourself and others from risk of serious injury. Read the user's manual and:

- Read the user's manual and follow all instructions.
- Check for proper assembly.
- Do not use the treadmill if you are injured, pregnant, or have any medical condition that may be affected by exercise.
- Do not use the treadmill if you are under the influence of alcohol or drugs.
- Do not use the treadmill if you are wearing loose clothing or jewelry.
- Do not use the treadmill if you are wearing shoes that are not designed for walking or running.
- Do not use the treadmill if you are wearing shoes that are not designed for walking or running.
- Do not use the treadmill if you are wearing shoes that are not designed for walking or running.



Note: This decal is shown at 38% of actual size.

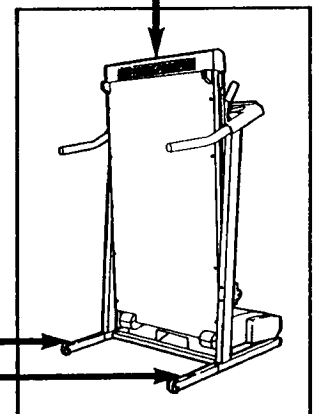

# BEFORE YOU BEGIN

Congratulations for selecting the new PROFORM® CROSSWALK 590 LS treadmill. The CROSSWALK 590 LS treadmill combines advanced technology with innovative design to help you get the most from your exercise in the convenience and privacy of your home. And when you're not exercising, the unique 590 LS can be folded up, requiring less than half the floor space of other treadmills.



**For your benefit, read this manual carefully before using the treadmill. If you have additional questions,**

please call our toll-free HELPLINE at 1-800-736-6879, Monday through Saturday, 7 a.m. until 7 p.m. Central Time (excluding holidays). To help us assist you, please note the product model number and serial number before calling. The model number of the treadmill is 831.299620. The serial number can be found on a decal attached to the treadmill (see the front cover of this manual for the location).

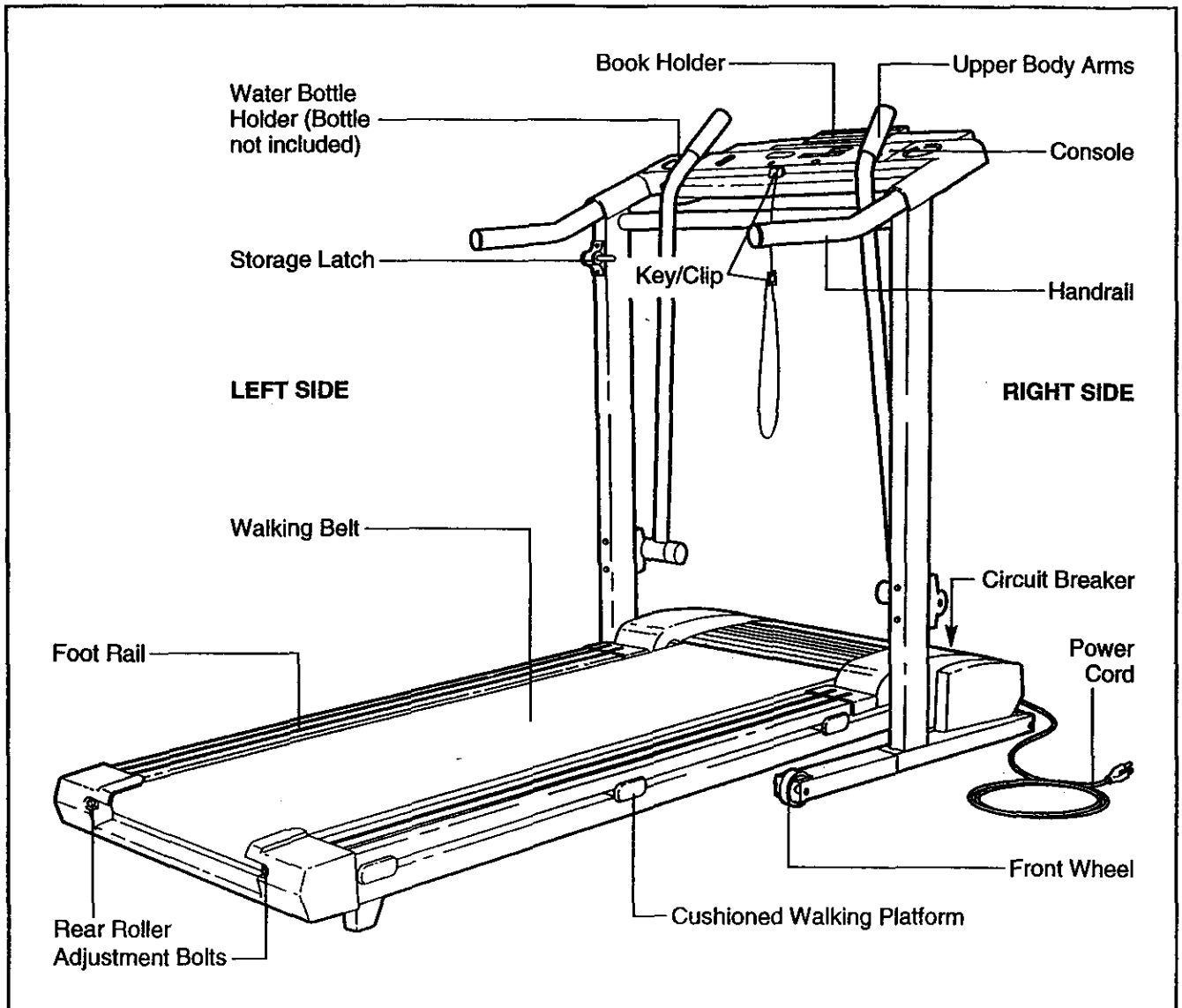
Before reading further, please review the drawing below and familiarize yourself with the parts that are labeled.

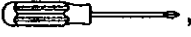
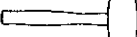

# ASSEMBLY

**Assembly requires two people.** Set the treadmill in a cleared area and remove all packing materials. Do not dispose of the packing materials until assembly is completed. Refer to the drawings below to identify small parts used in assembly. **Assembly requires the following tools: The included allen wrench and your own phillips screwdriver** , **mallet** , **wire cutters** , and **needle-nose pliers** .

Note: The underside of the treadmill walking belt is coated with high-performance lubricant. During shipping, a small amount of lubricant may be transferred to the top of the walking belt or the shipping carton. This is a normal condition and does not affect treadmill performance. If there is lubricant on top of the walking belt, simply wipe off the lubricant with a soft cloth and a mild, non-abrasive cleaner.

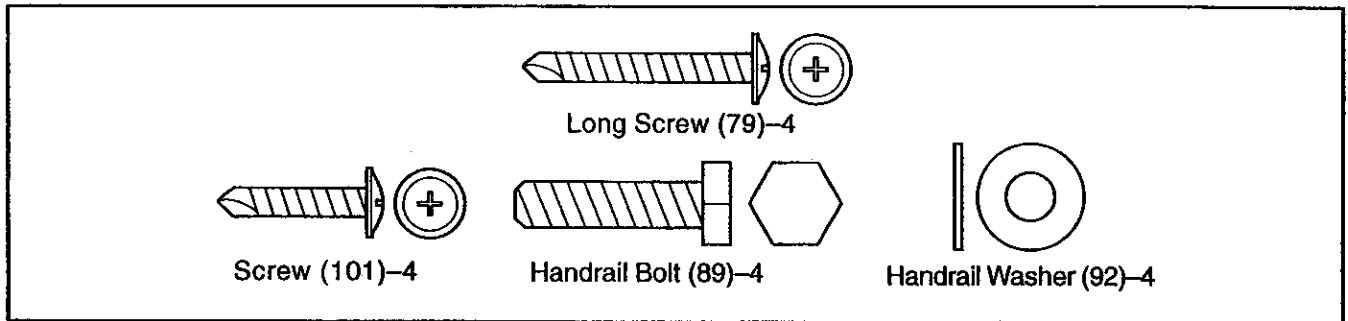

1. With the help of a second person, carefully raise the Uprights (82) until the treadmill is in the position shown.

Insert one of the Extension Legs (103) into the treadmill as shown. Make sure that the Thick Base Pad (97) is on the indicated side. Note: It may be helpful to tip the Uprights (82) in the direction shown by the arrows as you insert the Extension Leg. To fully insert the Extension Leg, it may be necessary to tap it with a mallet.

Insert the other Extension Leg (not shown) in the same way.

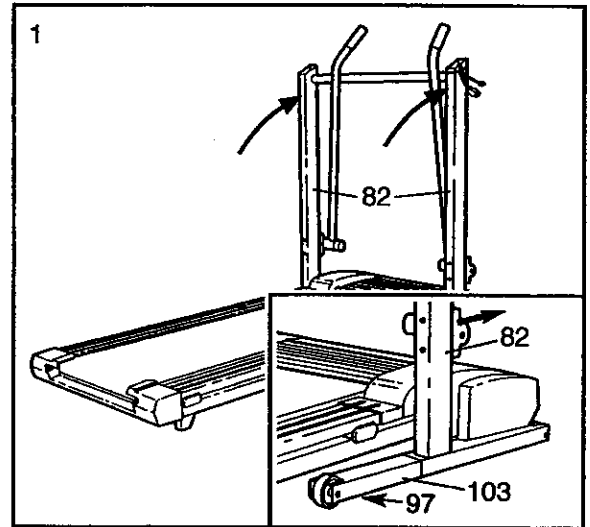

2. Refer to drawing 2a. If there are plastic ties in the Cage Nuts (36) in the Right Handrail (85), remove the plastic ties. Pull about 6" of the Wire Harness (17) out of the Right Upright (82). Route the Wire Harness through the bracket on the Right Handrail and out of the indicated hole. If necessary, use needle-nose pliers to grip the connectors on the Wire Harness. Thread the included wire tie through the indicated hole in the Right Handrail (85).

Refer to drawing 2b. Look into the Right Handrail (85) and make sure that the Wire Harness (17) is on the indicated side of the wire tie. Tighten the wire tie and cut the excess off the end.

Refer to drawing 2c. Insert the bracket on the Right Handrail (85) into the upper end of the right Upright (82). **Hand tighten** a Handrail Bolt (89) with a Handrail Washer (92) into each side of the Upright as shown.

Attach the Left Handrail (23) as described above. Note: There is not a wire in the left Upright (82).

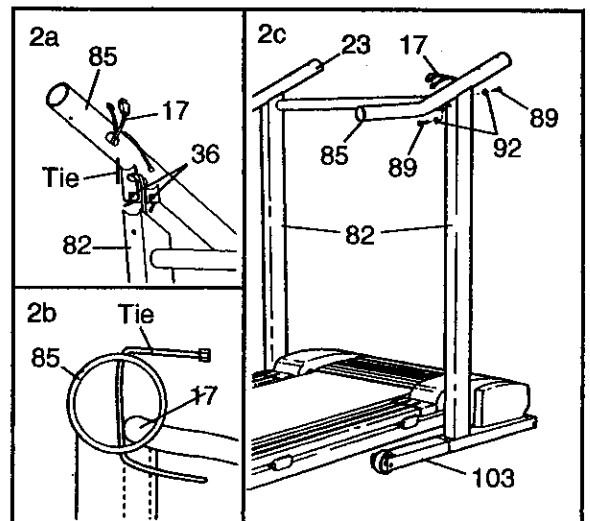

3. With the help of a second person, carefully tip the Uprights (82) down as shown. Note: It may be helpful to place a foot on one of the Wheels (95) as you tip the treadmill.

Attach each Extension Leg (103) with two Screws (101) and a Base Pad (52) as shown. Make sure that the Extension Legs are fully inserted into the Uprights (82); push down on the Uprights as you tighten the Screws.

Note: One replacement Base Pad (52) and Spacer (not shown) may be included. If a Base Pad becomes worn and needs to be replaced, use the replacement Base Pad. If a Thick Base Pad (97) needs to be replaced, use the replacement Base Pad with the Spacer.

With the help of a second person, carefully tip the Uprights (82) back to the upright position.

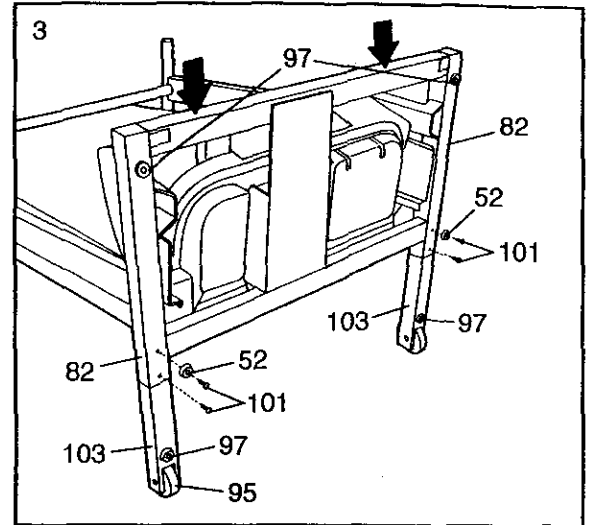

4. Place the Console Base (87) on the Handrails (85, 23). Make a loop with the indicated plastic tie and insert the two Wires (17) through the loop. Pull out just enough of the two Wires to connect them to the connectors in the Console Base, and then plug the Wires into the connectors. **Important: Make sure that the Wires are fully inserted.** Tighten the loop and cut off the excess plastic tie. **WARNING: Do not disconnect or connect the Wires while the treadmill power cord is plugged in.**

Refer to drawing 4b. Thread four Long Screws (79) into the Handrails (85, 23) and the Console Base (87). After all four Long Screws have been started, **tighten the Screws until they are snug; do not overtighten the Screws.**

Refer to drawing 2c. Tighten the four Handrail Bolts (89).

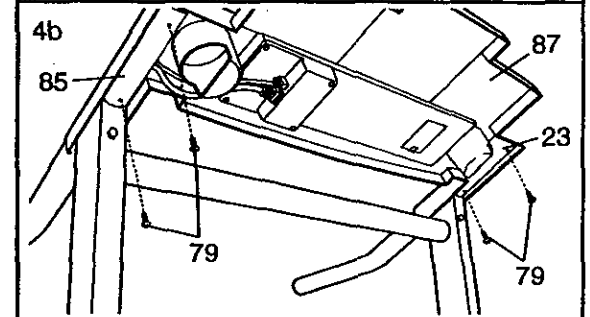
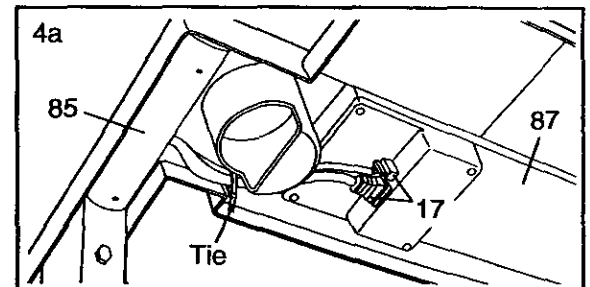

5. Remove the Lock Knob (105) from the Lock Pin (11).

Make sure that the Lock Pin Collar (14) and the Spring (56) are on the Lock Pin as shown. Insert the Lock Pin into the Latch Bracket (77).

Tighten the Lock Knob (105) onto the Lock Pin (11).

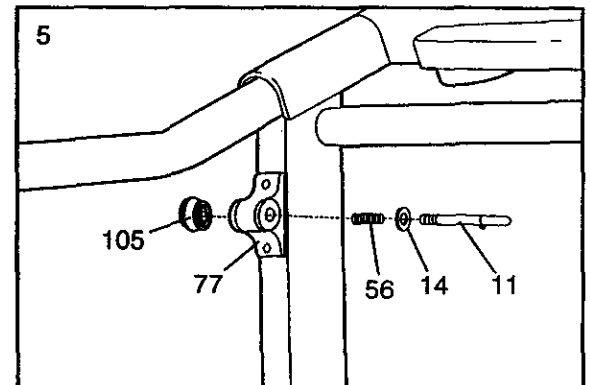

6. **Make sure that all parts are tightened before you use the treadmill.** Keep the included allen wrench in a secure place. The allen wrench is used to adjust the walking belt (see page 13). To protect the floor, place a mat under the treadmill.

# OPERATION AND ADJUSTMENT

## THE PERFORMANT LUBE™ WALKING BELT

Your treadmill features a walking belt coated with PERFORMANT LUBE™, a high-performance lubricant. **IMPORTANT:** Never apply silicone spray or other substances to the walking belt or the walking platform. Such substances will deteriorate the walking belt and cause excessive wear.

## HOW TO PLUG IN THE POWER CORD

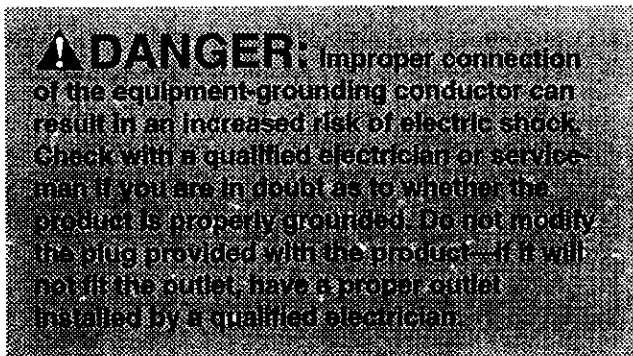

Your treadmill, like any other type of sophisticated electronic equipment, can be seriously damaged by sudden voltage changes in your home's power. Voltage surges, spikes, and noise interference can result from weather conditions or from other appliances being turned on or off. **To decrease the possibility of your treadmill being damaged, always use a surge suppressor with your treadmill (see drawing 1 at the right).** To purchase a surge suppressor, see your local SEARS or call 1-800-366-7278 and order part number 146148.

Use only a single-outlet surge suppressor that is UL 1449 listed as a transient voltage surge suppressor (TVSS). The surge suppressor must have a UL suppressed voltage rating of 400 volts or less and a minimum surge dissipation of 450 joules. The surge suppressor must be electrically rated for 120 volts AC and 15 amps. There must be a monitoring light on the surge suppressor to indicate whether it is functioning properly. Failure to use a properly functioning surge suppressor could result in damage to the control system of the treadmill. If the control system is damaged, the walking belt may change speed or stop unexpectedly, which may result in a fall and serious injury.

This product must be grounded. If it should malfunction or break down, grounding provides a path of least resistance for electric current to reduce the risk of electric shock. This product is equipped with a cord having

an equipment-grounding conductor and a grounding plug. **Plug the power cord into a surge suppressor, and plug the surge suppressor into an appropriate outlet that is properly installed and grounded in accordance with all local codes and ordinances. Important: The treadmill is not compatible with GFCI-equipped outlets.**

This product is for use on a nominal 120-volt circuit, and has a grounding plug that looks like the plug illustrated in drawing 1 below. A temporary adapter that looks like the adapter illustrated in drawing 2 may be used to connect the surge suppressor to a 2-pole receptacle as shown in drawing 2 if a properly grounded outlet is not available.

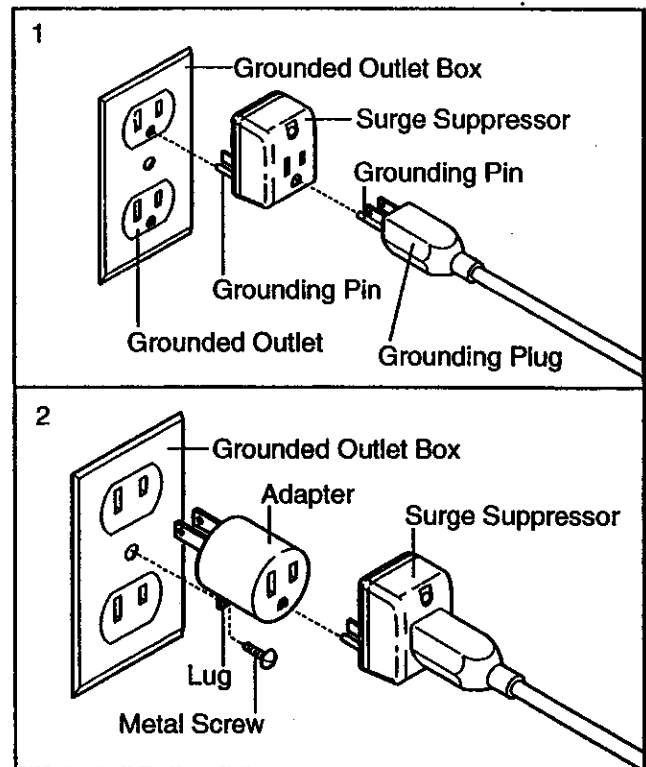

The temporary adapter should be used only until a properly grounded outlet (drawing 1) can be installed by a qualified electrician.

The green-colored rigid ear, lug, or the like extending from the adapter must be connected to a permanent ground such as a properly grounded outlet box cover. Whenever the adapter is used it must be held in place by a metal screw. **Some 2-pole receptacle outlet box covers are not grounded. Contact a qualified electrician to determine if the outlet box cover is grounded before using an adapter.**

## CONSOLE DIAGRAM

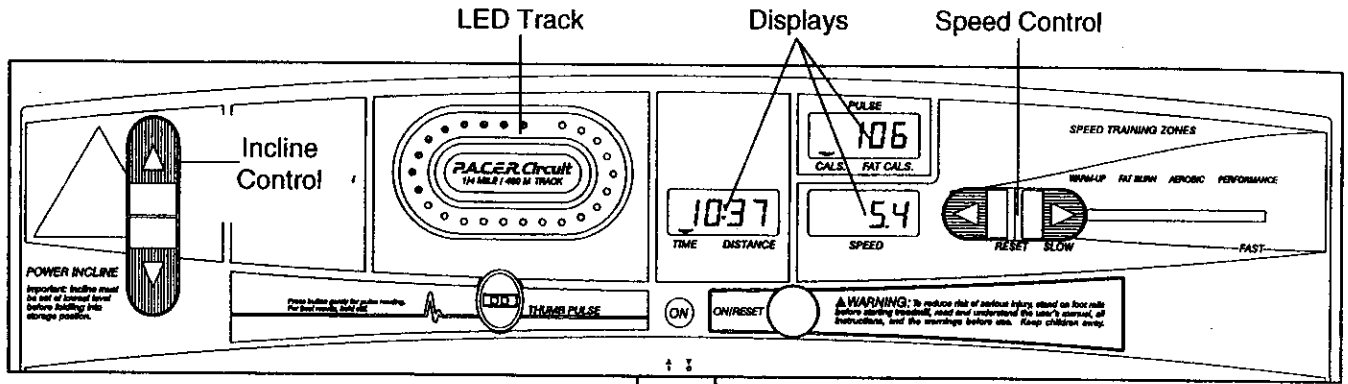

**Note:** If there is a thin sheet of clear plastic on the face of the console, remove it.

**CAUTION:** Before operating the console, read the following precautions.

- Do not stand on the walking belt when turning on the power.
- Always wear the clip (see the drawing above) while using the treadmill. When the key is removed from the console, the walking belt will stop.
- Adjust the speed in small increments.
- The training zones marked above the speed control are general guidelines only. See page 14 for more information.
- To reduce the possibility of electric shock, keep the console dry. Avoid spilling liquids on the console and use only a sealable water bottle.

## BATTERY INSTALLATION

The console requires three "AA" batteries (not included). Alkaline batteries are recommended. Open the battery cover as shown below. Insert three batteries into the battery compartment, making sure that the

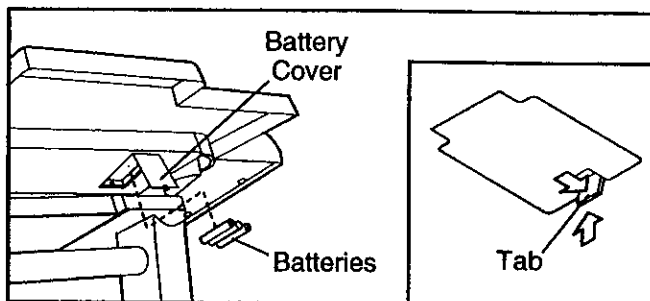

negative (-) ends of the batteries are touching the springs in the battery compartment. Close the battery cover, push up on the battery cover tab, and then push the tab forward as shown in the inset drawing. Be sure that the tab locks into place.

## STEP-BY-STEP CONSOLE OPERATION

Before operating the console, make sure that the power cord is properly plugged in. (See HOW TO PLUG IN THE POWER CORD on page 7.)

Stand on the foot rails of the treadmill. Find the clip attached to the key and slide the clip onto the waistband of your clothes. Next, insert the key into the console.

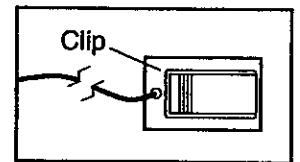

**Test the clip by carefully taking a few steps backward until the key is pulled from the console. If the key is not pulled from the console, adjust the position of the clip as needed.**

Follow the steps below to operate the console.

### 1 Insert the key fully into the power switch.

Inserting the key will not turn on the displays. The displays will turn on when the ON/RESET button is pressed or when the walking belt is started.

**Note:** If you just installed batteries, the displays will already be on.

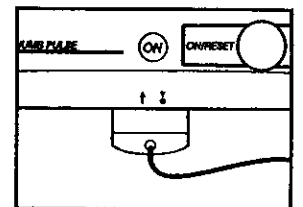



**2** Reset the speed control and start the walking belt.

Slide the speed control to the RESET position. (Note: Each time the walking belt is stopped, the speed control must be moved to the RESET position before the walking belt can be restarted.) Next, slowly slide the speed control to the right until the walking belt begins to move at slow speed. Step onto the walking belt and begin walking. As you exercise, change the speed of the walking belt as desired with the speed control.

To stop the walking belt, step onto the foot rails and slide the speed control to the RESET position.

Note: During the first few minutes that you use the treadmill, inspect the alignment of the walking belt, and align it if necessary (see page 13).

**3** Adjust the incline of the treadmill as desired.

To change the incline of the treadmill, press the top or bottom of the incline control until the desired incline level is reached.

**4** Follow your progress with the LED track and the three displays.

**The LED Track**—The LED track represents a distance of 1/4 mile. As you exercise, the indicators around the track will light in sequence until you have completed 1/4 mile. A new lap will then begin.

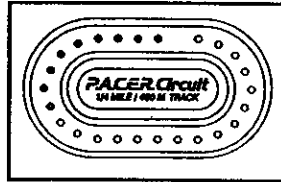

**TIME/DISTANCE display**—This display shows the elapsed time and the distance that you have walked or run, in miles. Every few seconds, the display will change from one number to the other, as shown by the arrows in the display.

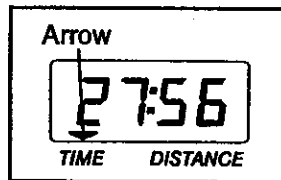

**CALS/PAT CALS/ PULSE display**—This display shows the approximate numbers of calories and fat calories you have burned. (See FAT BURNING on page 14.) Every few seconds, the display will change from one number to the other.

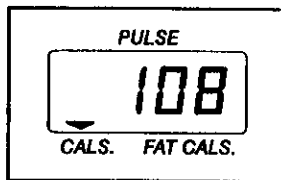

**SPEED display**—This display shows the speed of the walking belt, in miles per hour.

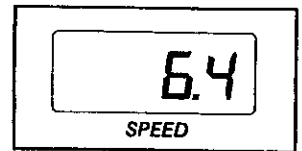

To reset the displays at any time, press the ON/RESET button.

**5** Measure your heart rate, if desired.

To measure your heart rate, stand on the foot rails and place your thumb on the pulse sensor as shown. The pulse sensor is pressure activated—fully press it down. Do not press too hard, or the circulation in your thumb will be restricted, and your pulse will not be detected.

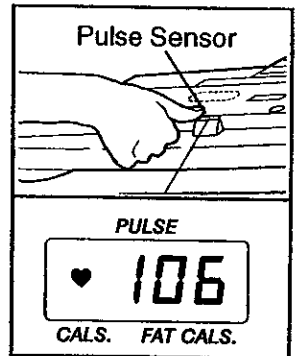

Next, raise your thumb slightly until the heart-shaped indicator in the CALS/FAT CALS/PULSE display flashes steadily. Hold your thumb at this level. After a few seconds, three dashes will appear in the display and then your heart rate will be shown. Hold your thumb on the pulse sensor for another 15 seconds for the most accurate reading.

If the displayed heart rate appears to be too high or too low, or if your heart rate is not displayed, lift your thumb off the pulse sensor and allow the display to reset. Then, press down on the pulse sensor as described above. Make sure that your thumb is positioned as shown, and that you are applying the proper amount of pressure. Remember to stand still while measuring your heart rate.

**6** When you are finished exercising, stop the walking belt and remove the key.

Step onto the foot rails, slide the speed control to the RESET position, and adjust the incline of the treadmill to the lowest level. The incline must be at the lowest level when the treadmill is raised to the storage position. Remove the key from the console. The displays will turn off about five minutes after the key is removed. Note: To conserve the batteries, the displays will automatically turn off any time that the walking belt is stopped and the ON/RESET button is not pressed for five minutes.

## HOW TO USE THE UPPER BODY ARMS

As you exercise on the treadmill, you can hold either the handrails or the upper body arms. The upper body arms are designed to exercise your arms, shoulders, and back for a total body workout. Hold one upper body arm with each hand, and move them forward and back as you walk on the treadmill.

To vary the intensity of your upper body exercise, the resistance of the upper body arms can be adjusted. To increase the resistance, turn the resistance knobs clockwise; to decrease the resistance, turn the knobs counterclockwise.

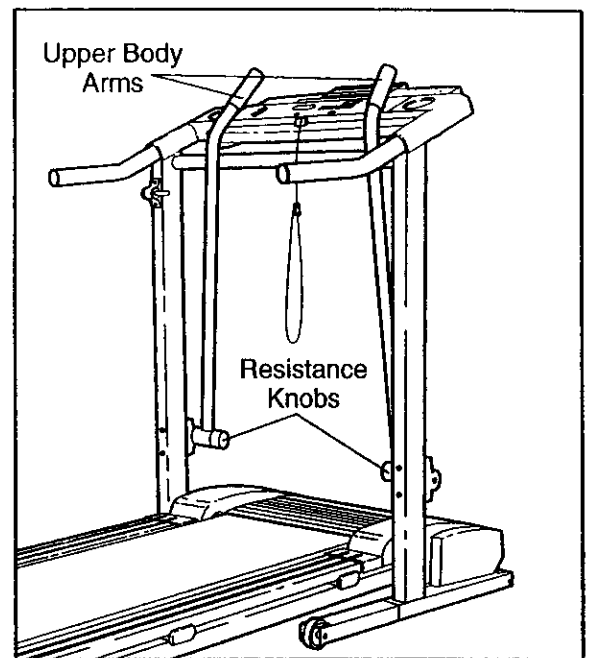

## HOW TO FOLD AND MOVE THE TREADMILL

### HOW TO FOLD THE TREADMILL FOR STORAGE

Before folding the treadmill, adjust the incline to the lowest position. If this is not done, the treadmill may be damaged. Next, unplug the power cord. **CAUTION: You must be able to safely lift 45 pounds (20 kg) in order to raise, lower, or move the treadmill.**

1. Hold the treadmill with your hands in the locations shown at the right. (**CAUTION: To decrease the possibility of injury, bend your legs and keep your back straight. As you raise the treadmill, make sure to lift with your legs rather than your back.**) Raise the treadmill about halfway to the vertical position.
2. Move your right hand to the position shown and hold the treadmill firmly. Hold the lock knob with your left hand and pull it to the left. Raise the treadmill until the lock knob is aligned with the slot in the catch. (Note: You may need to push the handrail to the left slightly). Slowly release the knob; make sure that the pin on the lock knob is inserted into the slot in the catch.

To protect the floor or carpet from damage, place a mat under the treadmill. Keep the treadmill out of direct sunlight. Do not leave the treadmill in the storage position in temperatures above 85° Fahrenheit.

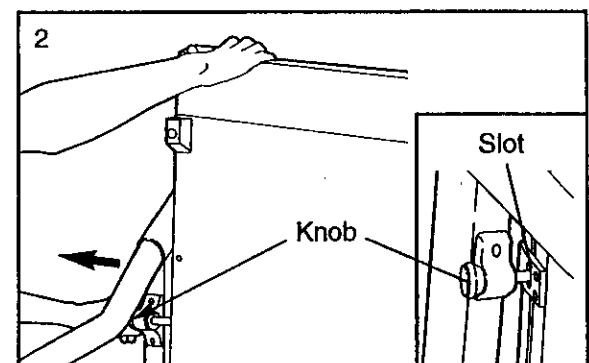
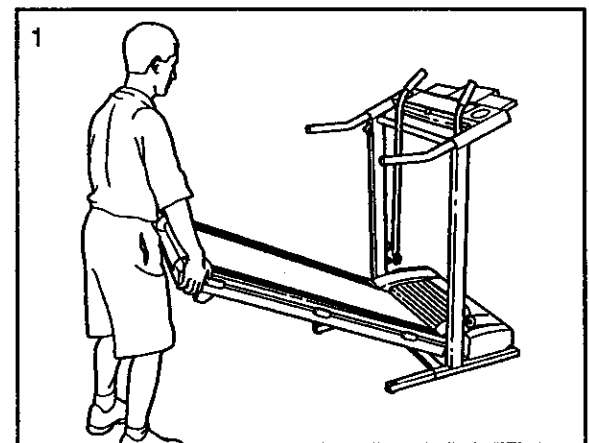

## HOW TO MOVE THE TREADMILL

Before moving the treadmill, convert the treadmill to the storage position as described above. **Make sure that the pin on the lock knob is inserted into the slot in the catch.**

1. Hold the handrails as shown and place one foot against a wheel.
2. Tilt the treadmill back until it rolls freely on the front wheels. Carefully move the treadmill to the desired location. **Never move the treadmill without tipping it back. To reduce the risk of injury, use extreme caution while moving the treadmill. Do not attempt to move the treadmill over an uneven surface.**
3. Place one foot on the wheel, and carefully lower the treadmill until it is resting in the storage position.

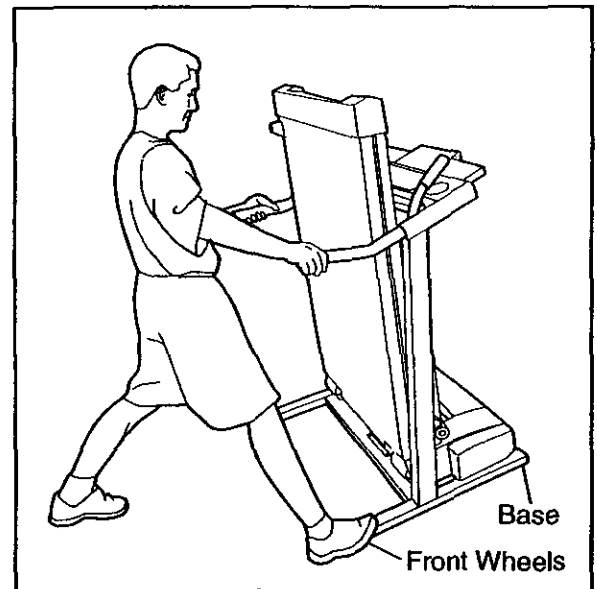

## HOW TO LOWER THE TREADMILL FOR USE

1. Hold the upper end of the treadmill with your right hand as shown. Using your left hand, pull the lock knob to the left and hold it. Pivot the treadmill until the frame and foot rail are past the pin on the lock knob. If necessary, push the handrail to the left slightly.
2. Hold the treadmill firmly with both hands, and lower the treadmill to the floor. **Do not drop the treadmill frame to the floor. To decrease the possibility of injury, bend your legs and keep your back straight.**

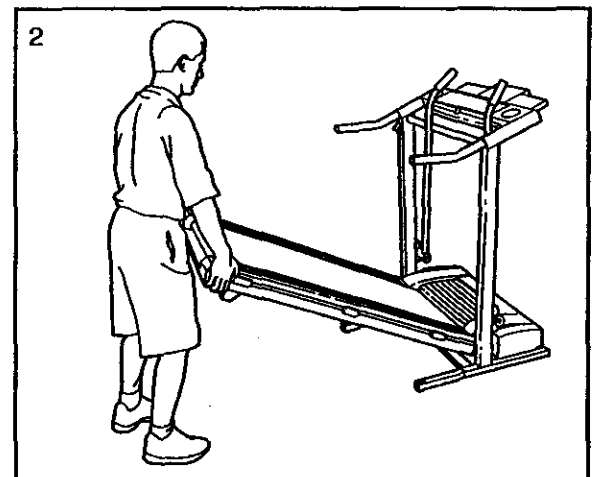
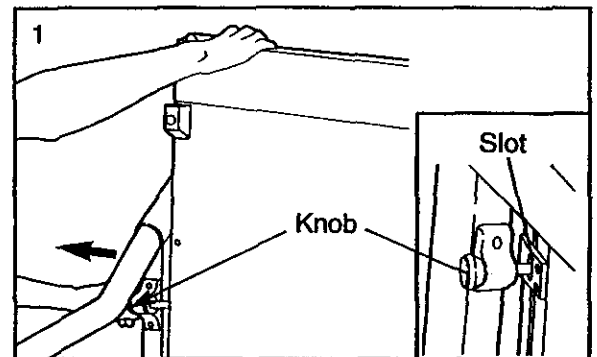

# TROUBLE-SHOOTING

Most treadmill problems can be solved by following the simple steps below. Find the symptom that applies, and follow the steps listed. If further assistance is needed, call our toll-free HELPLINE at 1-800-736-6879, Monday through Saturday, 7 a.m. until 7 p.m. Central Time (excluding holidays).

**PROBLEM:** The power does not turn on

**SOLUTION:** a. Make sure that the power cord is plugged into a surge suppressor, and that the surge suppressor is plugged into a properly grounded outlet (see page 7). Use only a single-outlet surge suppressor that meets all of the specifications described on page 7. Important: The treadmill is not compatible with GFCI-equipped outlets.

b. After the power cord has been plugged in, make sure that the key is fully inserted into the console.

c. Check the circuit breaker located on the treadmill near the power cord. If the switch protrudes as shown, the circuit breaker has tripped. To reset the circuit breaker, wait for five minutes and then press the switch back in.

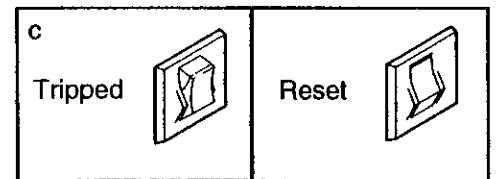

**PROBLEM:** The power turns off during use

**SOLUTION:** a. Check the circuit breaker located on the treadmill frame near the power cord (see c. above). If the circuit breaker has tripped, wait for five minutes and then press the switch back in.

b. Make sure that the power cord is plugged in.

c. Make sure that the two wires under the console are fully plugged in (refer to assembly step 4 on page 6). **WARNING: Do not disconnect or connect the wires while the power cord is plugged in.**

d. Unplug the power cord, wait for five minutes, and then plug the power cord back in.

e. Remove the key from the console. Reinsert the key fully into the console.

f. If the treadmill still will not run, please call our toll-free HELPLINE.

**PROBLEM:** The displays on the console do not function properly

**SOLUTION:** a. Remove the key from the console and **unplug the power cord**. Remove the screws from the hood and carefully remove the hood. Locate the Reed Switch (21) and the Magnet (43) on the left side of the Pulley (42). Turn the Pulley until the Magnet is aligned with the Reed Switch. **Make sure that the gap between the Magnet and the Reed Switch is about 1/8"**. If necessary, loosen the Reed Switch Screw (76) and move the Reed Switch slightly. Retighten the Screw. Re-attach the hood, and run the treadmill for a few minutes to check for a correct speed reading.

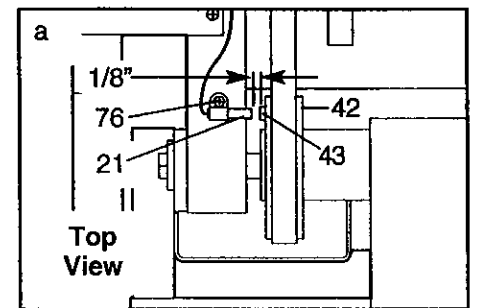

**PROBLEM:** The pulse display on the console does not function properly

**SOLUTION:** a. Wash your hands before using the pulse sensor. Clean the pulse sensor with a damp cloth and mild detergent.

**PROBLEM: The incline system does not function properly**

**SOLUTION:** a. Make sure that the two wires under the console are fully plugged in (refer to assembly step 4 on page 6). **WARNING: Do not disconnect or connect the wires while the treadmill power cord is plugged in.**

**PROBLEM: The walking belt slows when walked on**

**SOLUTION:** a. Use only a single-outlet surge suppressor that meets all of the specifications described on page 7.

- b. If the walking belt is overtightened, treadmill performance may decrease and the walking belt may become damaged. Remove the key and **UNPLUG THE POWER CORD**. Using the allen wrench, turn both rear roller adjustment bolts counterclockwise, 1/4 of a turn. When the walking belt is properly tightened, you should be able to lift each side of the walking belt 3 to 4 inches off the walking platform. Be careful to keep the walking belt centered. Plug in the power cord, insert the key and run the treadmill for a few minutes. Repeat until the walking belt is properly tightened.

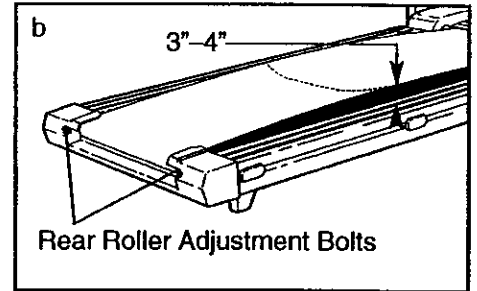

- c. If the walking belt still slows when walked on, please call our toll-free HELPLINE.

**PROBLEM: The walking belt is off-center or slips when walked on**

**SOLUTION:** a. If the walking belt is off-center, remove the key and **UNPLUG THE POWER CORD**. If the walking belt has shifted to the left, use the allen wrench to turn the left rear roller bolt clockwise 1/2 of a turn; if the walking belt has shifted to the right, turn the left rear roller bolt counterclockwise 1/2 of a turn. Be careful not to overtighten the walking belt. Plug in the power cord, insert the key and run the treadmill for a few minutes. Repeat until the walking belt is centered.

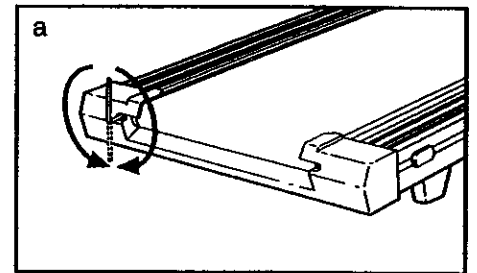

- b. If the walking belt slips when walked on, first remove the key and **UNPLUG THE POWER CORD**. Using the allen wrench, turn both rear roller bolts clockwise, 1/4 of a turn. When the walking belt is correctly tightened, you should be able to lift each side of the walking belt 3 to 4 inches off the walking platform. Be careful to keep the walking belt centered. Plug in the power cord, insert the key and carefully walk on the treadmill for a few minutes. Repeat until the walking belt is properly tightened.

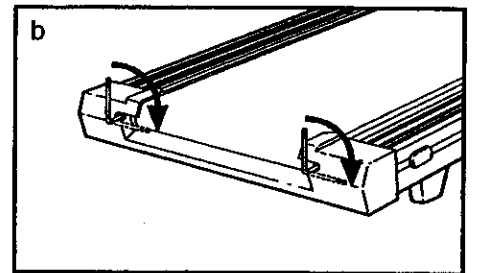

**PROBLEM: ONE OF THE UPPER BODY ARMS SQUEAKS DURING USE**

**SOLUTION:** a. A small amount of white marine grease, available at most hardware stores, is needed. Turn the Resistance Knob (119) counterclockwise until it can be removed. Remove the Resistance Cone (114) and the Upper Body Arm (110, 115), along with the 3/8" Washers (108), Spring Washer (116), Thrust Washers (117), and Thrust Bearing (118). (Note: If the Resistance Sleeve [113] comes out of the Resistance Bracket [112], press it back in.) Apply a thin layer of white marine grease to the outer surface of the Resistance Cone (114). Reattach all parts in the order shown at the right.

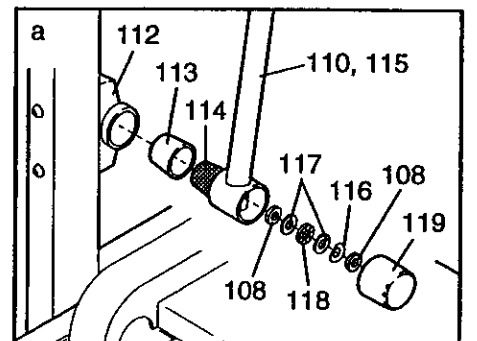

# CONDITIONING GUIDELINES

**⚠ WARNING:** Before beginning this or any exercise program, consult your physician. This is especially important for individuals over the age of 35 or individuals with pre-existing health problems.

The pulse sensor is not a medical device. Various factors, including your movement, may affect the accuracy of heart rate readings. The sensor is intended only as an exercise aid in determining heart rate trends in general.

The following guidelines will help you to plan your exercise program. For more detailed exercise information, obtain a reputable book or consult your physician.

## EXERCISE INTENSITY

Whether your goal is to burn fat or to strengthen your cardiovascular system, the key to achieving the desired results is to exercise with the proper intensity. The proper intensity level can be found by using your heart rate as a guide. The chart below shows recommended heart rates for fat burning and aerobic exercise.

AEROBIC	185	155	145	140	130	125	115
MAX FAT BURN	145	135	130	125	115	110	103
FAT BURN	125	120	115	110	105	95	90
Age	20	30	40	50	60	70	80

To find the proper heart rate for you, first find your age near the bottom of the chart (ages are rounded off to the nearest ten years). Next, find the three numbers above your age. The three numbers define your "training zone." The lower two numbers are recommended heart rates for fat burning; the higher number is the recommended heart rate for aerobic exercise.

## Fat Burning

To burn fat effectively, you must exercise at a relatively low intensity level for a sustained period of time. During the first few minutes of exercise, your body uses easily accessible *carbohydrate calories* for energy. Only after the first few minutes does your body begin to use stored *fat calories* for energy. If your goal

is to burn fat, adjust the speed and incline of the treadmill until your heart rate is near the lowest number in your training zone.

For maximum fat burning, adjust the speed and incline of the treadmill until your heart rate is near the middle number in your training zone.

## Aerobic Exercise

If your goal is to strengthen your cardiovascular system, your exercise must be "aerobic." Aerobic exercise is activity that requires large amounts of oxygen for prolonged periods of time. This increases the demand on the heart to pump blood to the muscles, and on the lungs to oxygenate the blood. For aerobic exercise, adjust the speed and incline of the treadmill until your heart rate is near the highest number in your training zone.

## WORKOUT GUIDELINES

Each workout should include the following three parts:

**A Warm-up**—Start each workout with 5 to 10 minutes of stretching and light exercise. A proper warm-up increases your body temperature, heart rate and circulation in preparation for exercise.

**Training Zone Exercise**—After warming up, increase the intensity of your exercise until your pulse is in your training zone for 20 to 60 minutes. (During the first few weeks of your exercise program, do not keep your pulse in your training zone for longer than 20 minutes.) Breathe regularly and deeply as you exercise—never hold your breath.

**A Cool-down**—Finish each workout with 5 to 10 minutes of stretching to cool down. This will increase the flexibility of your muscles and will help prevent post-exercise problems.

## EXERCISE FREQUENCY

To maintain or improve your condition, complete three workouts each week, with at least one day of rest between workouts. After a few months, you may complete up to five workouts each week if desired.

The key to success is to make exercise a regular and enjoyable part of your everyday life.

# PART LIST—Model No. 831.299620

R0102A

To locate the parts listed below, refer to the EXPLODED DRAWING attached in the center of this manual.

Key No.	Qty.	Description	Key No.	Qty.	Description	Key No.	Qty.	Description
1	1	Motor Belt	47	13	Belly Pan Fastener	92	10	Roller Adj. Washer/
2	1	Pulley/Flywheel/Fan	48	1	Shield			Handrail Washer
3	4	Motor Nut	49	2	Belt Guide	93	1	Book Holder
4*	1	Motor/Pulley/ Flywheel/ Fan	50	1	Battery Cover	94	1	Motor Hood
5	2	Incline Motor Bolt	51	1	Front Belly Pan	95	2	Front Wheel
6	2	Incline Motor Spacer	52	2	Base Pad	96	1	Incline Motor Shield
7	1	Incline Motor	53	3	Cable Tie Clamp	97	4	Thick Base Pad
8	1	Stop Bracket	54	4	Cable Tie	98	1	Trim Guard
9	1	Speed Control	55	1	Walking Belt	99	1	Upright Grommet
10	1	Incline Control	56	1	Spring	100	1	Allen Wrench
11	1	Lock Pin	57	1	Rear Roller	101	18	Screw
12	1	Frame	58	2	Rear Isolator	102	2	Handrail Endcap
13	1	Pin Clip	59	2	Rear Foot	103	2	Extension Leg
14	1	Lock Pin Collar	60	4	Rear Foot Screw	104	2	Extension Leg Cap
15	8	Incline Motor Nut	61	1	Ground Wire	105	1	Lock Knob
16	4	Belt Guide Screw	62	1	Hood Bracket Plate	106	1	Choke
17	1	Wire Harness	63	1	Belly Pan	107	4	Resistance Bracket Bolt
18	2	Rubber Hood Bracket	64	1	Rear Endcap			
19	1	Front Hood Bracket	65	2	Rear Roller Adj. Bolt	108	4	3/8" Washer
20	2	Warning Decal	66	1	Motor	109	2	Foam Grip
21	1	Reed Switch	67	1	Latch Decal	110	1	Left Upper Body Arm w/Foam Grip
22	1	Reed Switch Clip	68	4	Rear Platform Screw			
23	1	Left Handrail	69	2	Latch Catch Screw	111	2	Resistance Bolt
24	1	Controller	70	1	Latch Catch	112	2	Resistance Bracket
25	1	Electronics Bracket	71	1	Walking Platform	113	2	Resistance Sleeve
26	1	Circuit Breaker	72	5	8" Cable Tie	114	2	Resistance Cone
27	1	Power Cord	73	2	Interface Bracket	115	1	Right Upper Body Arm w/Foam Grip
28	1	Power Cord Grommet	74	1	Motor Tension Bolt			
29	20	Hood Screw	75	2	Foot Rail Insert	116	2	Spring Washer
30*	1	Latch Assembly	76	6	Reed Switch Screw/ Belly Pan Screw	117	4	Thrust Washer
31	1	Incline Frame	77	1	Storage Latch Bracket	118	2	Thrust Bearing
32	2	Frame Pivot Bolt	78*	2	Extension Leg Assembly	119	2	Resistance Knob
33	2	Frame Pivot Spacer				120	4	Star Washer
34	1	Tension Bushing	79	4	Long Screw	121	1	Foot Rail Cap (Right)
35	1	Front Roller Adj. Bolt	80	1	Wire Cover	122	7	Console Base Screw
36	4	Cage Nut	81	8	Motor Star Washer	#	1	8" White Wire, Pigtail
37	1	Motor Tension Nut	82	1	Upright	#	1	8" Green Wire, 2 Ring
38	4	Motor Bolt	83	2	Incline Leg Pivot Bolt			User's Manual
39	2	Cap Screw	84	1	Motor Tension Washer			
40	1	Foot Rail Cap (Left)	85	1	Right Handrail			
41	2	Foot Rail	86	2	Wheel Bolt			
42	1	Front Roller/Pulley	87	1	Console Base			
43	1	Magnet	88*	1	Console Assembly			
44	4	Platform Screw	89	4	Handrail Bolt			
45	4	Isolator	90	1	Key/Clip			
46	4	Isolator Screw	91	1	Incline Motor Belly Pan			

\* Includes all parts shown in the box

# These parts are not illustrated

EXPLODED DRAWING—Model No. 831.299620

R0102A

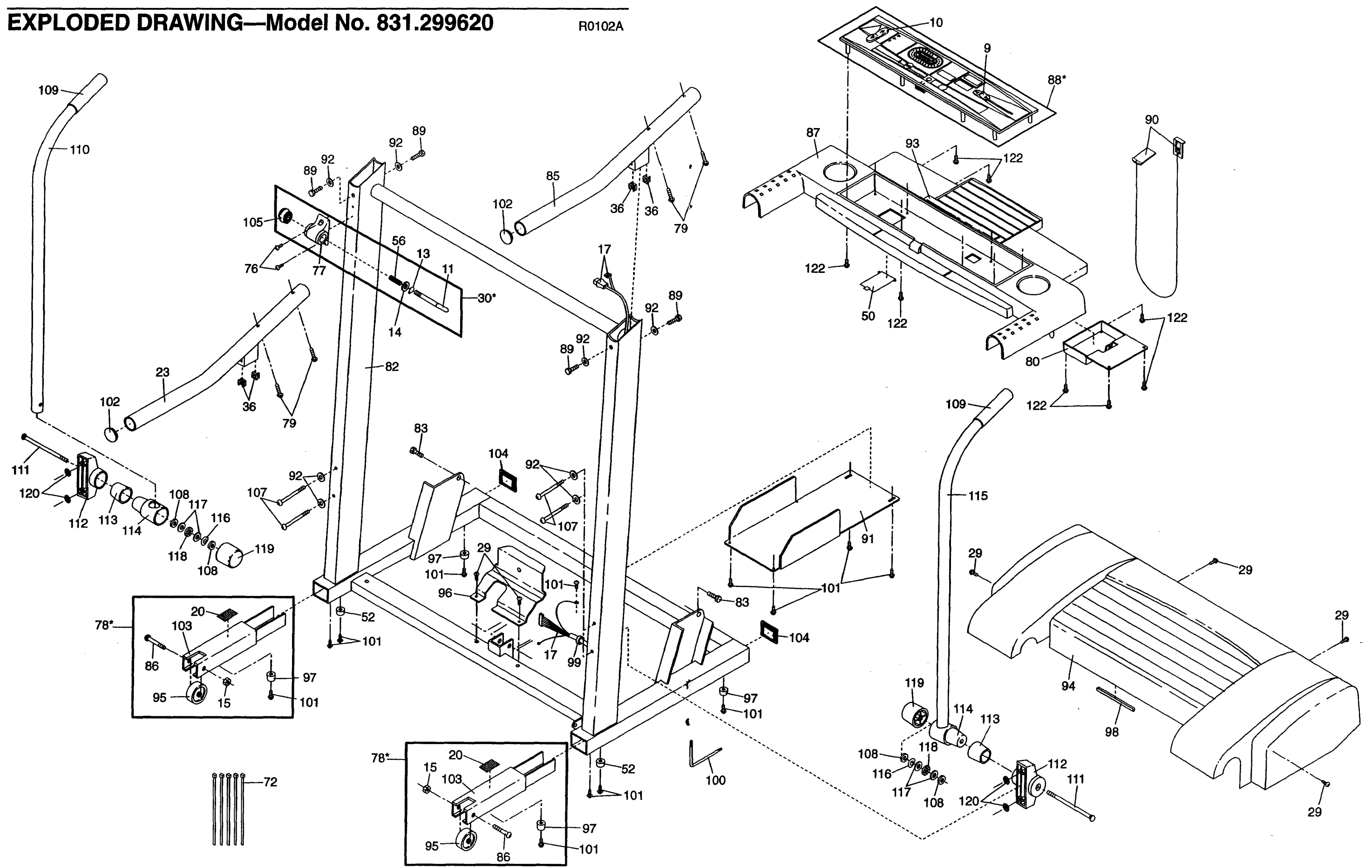



# EXPLODED DRAWING—Model No. 831.299620

R0102A

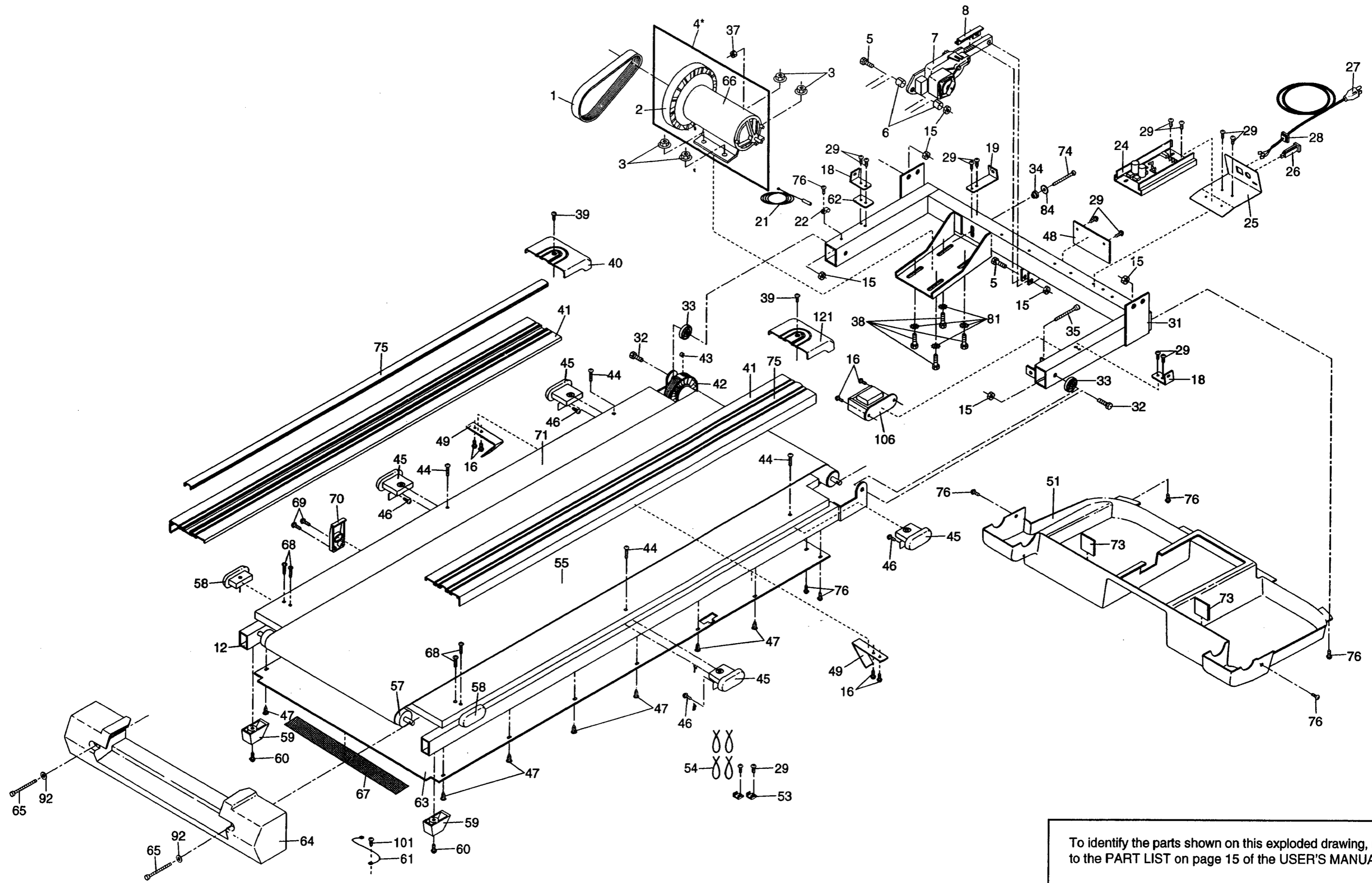

To identify the parts shown on this exploded drawing, refer to the PART LIST on page 15 of the USER'S MANUAL.



Model No. 831.299620

## QUESTIONS?

If you find that:

- you need help assembling or operating the PROFORM® CROSSWALK 590 LS treadmill
- a part is missing
- or you need to schedule repair service

call our toll-free HELPLINE

**1-800-736-6879**

Monday–Saturday, 7 am–7 pm  
Central Time (excluding holidays)

## REPLACEMENT PARTS

If parts become worn and need to be replaced, call the following toll-free number

**1-800-FON-PART**  
**(1-800-366-7278)**

The model number and serial number of your PROFORM CROSSWALK® 590 LS treadmill are listed on a decal attached to the frame. See the front cover of this manual to find the location of the decal.

All replacement parts are available for immediate purchase or special order when you visit your nearest SEARS Service Center. To request service or to order parts by telephone, call the toll-free numbers listed at the left.

When requesting help or service, or ordering parts, please be prepared to provide the following information:

- The NAME OF THE PRODUCT (PROFORM® CROSSWALK 590 LS treadmill)
- The MODEL NUMBER OF THE PRODUCT (831.299620)
- The KEY NUMBER AND DESCRIPTION OF THE PART (see the EXPLODED DRAWING and PART LIST in the center of this manual).

## FULL 90 DAY WARRANTY

For 90 days from the date of purchase, if failure occurs due to defect in material or workmanship in this SEARS TREADMILL EXERCISER, contact the nearest SEARS Service Center throughout the United States and SEARS will repair or replace the TREADMILL EXERCISER, free of charge.

This warranty does not apply when the TREADMILL EXERCISER is used commercially or for rental purposes.

This warranty gives you specific legal rights, and you may also have other rights which vary from state to state.

**SEARS, ROEBUCK AND CO., DEPT. 817WA, HOFFMAN ESTATES, IL 60179**