

Owner's Manual



GARDEN TRACTOR

23.0 HP, 48" Mower

Electric Start

6 Speed Transaxle

Model No.

917.275012

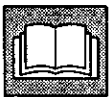
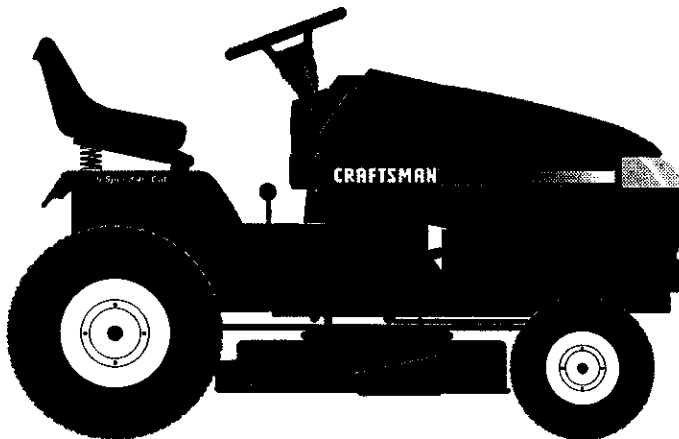

This product has a low emission engine which operates differently from previously built engines. Before you start the engine, read and understand this Owner's Manual.

CAUTION:

Read and follow all Safety Rules and Instructions before operating this equipment.

For answers to your questions about this product, Call:

1-800-659-5917

Sears Craftsman Help Line
5 am - 5 pm, Mon - Sat

SEARS, ROEBUCK AND CO., HOFFMAN ESTATES, IL 60179 U.S.A.

Visit our Craftsman website: www.sears.com/craftsman

TABLE OF CONTENTS

Warranty	2	Maintenance	16
Safety Rules	3	Service and Adjustments	21
Product Specifications	6	Storage	29
Assembly/Pre-Operation	8	Troubleshooting	30
Operation	10	Repair Parts	34
Maintenance Schedule	16	Sears Service	Back Cover

WARRANTY

LIMITED WARRANTY ON CRAFTSMAN RIDING EQUIPMENT

For two (2) years from the date of purchase, if this Craftsman Riding Equipment is maintained, lubricated and tuned up according to the instructions in the owner's manual, Sears will repair or replace free of charge any parts that are found to be defective in material or workmanship according to the guidelines of coverage listed below. Sears will also provide free labor for these applicable warranted parts for the two full years. During the first 30 days of purchase, there will be no charges to service the product at your home for issues covered by this warranty. (See exclusions below). For your convenience, IN HOME warranty service will still be available after the first 30 days of purchase, but a trip charge will apply. This charge will be waived if the Craftsman product is dropped off at an authorized Sears location. For the nearest authorized Sears location, please call 1-800-4-MY-HOME®. This warranty applies only while this product is within the United States.

This Warranty does not cover:

- Expendable items which become worn during normal use, including but not limited to blades, spark plugs, air cleaners, belts, and oil filters.
- Standard Maintenance Servicing, oil changes, or tune-ups
- Tire replacement or repair caused by punctures from outside objects, such as nails, thorns, stumps, or glass.
- Repairs necessary because of operator abuse, including but not limited to, damage caused by towing objects beyond the capability of the riding equipment, impacting objects that bend the frame or crankshaft, or over-speeding the engine.
- Repairs necessary because of operator negligence, including but not limited to, electrical and mechanical damage caused by improper storage, failure to use the proper grade and amount of engine oil, failure to keep the deck clear of flammable debris, or failure to maintain the equipment according to the instructions contained in the owner's manual.
- Engine (fuel system) cleaning or repairs caused by fuel determined to be contaminated or oxidized (stale). In general, fuel should be used within 30 days of its purchase date.
- Normal deterioration and wear of the exterior finishes, or product label replacement.
- Riding equipment used for commercial or rental purposes.

LIMITED WARRANTY ON BATTERY

For ninety (90) days from date of purchase, if any battery included with this riding equipment proves defective in material or workmanship and our testing determines the battery will not hold a charge, Sears will replace the battery at no charge. During the first 30 days of purchase, there will be no charges to replace the battery at your HOME. After the first 30 days, for your convenience, IN-HOME warranty service will still be available but a trip charge will apply. This charge will be waived if the Craftsman product is dropped off at an authorized Sears location. For the nearest authorized Sears location, please call 1-800-4-MY-HOME®.

This battery warranty applies only while this product is within the United States.

This warranty gives you specific legal rights, and you may also have other rights, which vary, from state to state.

Sears, Roebuck and Co., Dept. 817WA, Hoffman Estates, IL 60179

SAFETY RULES

IMPORTANT: This cutting machine is capable of amputating hands and feet and throwing objects. Failure to observe the following safety instructions could result in serious injury or death.

 Look for this symbol to point out important safety precautions. It means **CAUTION!!! BECOME ALERT!!! YOUR SAFETY IS INVOLVED.**

 **CAUTION:** In order to prevent accidental starting when setting up, transporting, adjusting or making repairs, always disconnect spark plug wire and place wire where it cannot contact spark plug.

 **CAUTION:** Do not coast down a hill in neutral, you may lose control of the tractor.

 **CAUTION:** Tow only the attachments that are recommended by and comply with specifications of the manufacturer of your tractor. Use common sense when towing. Operate only at the lowest possible speed when on a slope. Too heavy of a load, while on a slope, is dangerous. Tires can lose traction with the ground and cause you to lose control of your tractor.

 **WARNING:** Engine exhaust, some of its constituents, and certain vehicle components contain or emit chemicals known to the State of California to cause cancer and birth defects or other reproductive harm.

 **WARNING:** Battery posts, terminals and related accessories contain lead and lead compounds, chemicals known to the State of California to cause cancer and birth defects or other reproductive harm. **Wash hands after handling.**

I. GENERAL OPERATION

- Read, understand, and follow all instructions in the manual and on the machine before starting.
- Only allow responsible adults, who are familiar with the instructions, to operate the machine.
- Clear the area of objects such as rocks, toys, wire, etc., which could be picked up and thrown by the blade.
- Be sure the area is clear of other people before mowing. Stop machine if anyone enters the area.

- Never carry passengers.
- Do not mow in reverse unless absolutely necessary. Always look down and behind before and while backing.
- Be aware of the mower discharge direction and do not point it at anyone. Do not operate the mower without either the entire grass catcher or the guard in place.
- Slow down before turning.
- Never leave a running machine unattended. Always turn off blades, set parking brake, stop engine, and remove keys before dismounting.
- Turn off blades when not mowing.
- Stop engine before removing grass catcher or unclogging chute.
- Mow only in daylight or good artificial light.
- Do not operate the machine while under the influence of alcohol or drugs.
- Watch for traffic when operating near or crossing roadways.
- Use extra care when loading or unloading the machine into a trailer or truck.
- Data indicates that operators, age 60 years and above, are involved in a large percentage of riding mower-related injuries. These operators should evaluate their ability to operate the riding mower safely enough to protect themselves and others from serious injury.
- Keep machine free of grass, leaves or other debris build-up which can touch hot exhaust / engine parts and burn. Do not allow the mower deck to plow leaves or other debris which can cause build-up to occur. Clean any oil or fuel spillage before operating or storing the machine. Allow machine to cool before storage.

II. SLOPE OPERATION

Slopes are a major factor related to loss-of-control and tipover accidents, which can result in severe injury or death. All slopes require extra caution. If you cannot back up the slope or if you feel uneasy on it, do not mow it.

SAFETY RULES

DO:

- Mow up and down slopes, not across.
- Remove obstacles such as rocks, tree limbs, etc.
- Watch for holes, ruts, or bumps. Uneven terrain could overturn the machine. *Tall grass can hide obstacles.*
- Use slow speed. Choose a low gear so that you will not have to stop or shift while on the slope.
- Follow the manufacturer's recommendations for wheel weights or counterweights to improve stability.
- Use extra care with grass catchers or other attachments. These can change the stability of the machine.
- Keep all movement on the slopes *slow* and *gradual*. Do not make sudden changes in speed or direction.
- Avoid starting or stopping on a slope. If tires lose traction, disengage the blades and proceed slowly *straight* down the slope.

DO NOT:

- *Do not* turn on slopes unless necessary, and then, turn slowly and gradually downhill, if possible.
- *Do not* mow near drop-offs, ditches, or embankments. The mower could suddenly turn over if a wheel is over the edge of a cliff or ditch, or if an edge caves in.
- *Do not* mow on wet grass. Reduced traction could cause sliding.
- *Do not* try to stabilize the machine by putting your foot on the ground.
- *Do not* use grass catcher on steep slopes.

III. CHILDREN

Tragic accidents can occur if the operator is not alert to the presence of children. Children are often attracted to the machine and the mowing activity. *Never* assume that children will remain where you last saw them.

- Keep children out of the mowing area and under the watchful care of another responsible adult.
- Be alert and turn machine off if children enter the area.
- Before and when backing, look behind and *down* for small children.

- Never carry children. They may fall off and be seriously injured or interfere with safe machine operation.
- Never allow children to operate the machine.
- Use extra care when approaching blind corners, shrubs, trees, or other objects that may obscure vision.

IV. SERVICE

- Use extra care in handling gasoline and other fuels. They are flammable and vapors are explosive.
 - Use only an approved container.
 - Never remove gas cap or add fuel with the engine running. Allow engine to cool before refueling. Do not smoke.
 - Never refuel the machine indoors.
 - Never store the machine or fuel container inside where there is an open flame, such as a water heater.
- Never run a machine inside a closed area.
- Keep nuts and bolts, especially blade attachment bolts, tight and keep equipment in good condition.
- Never tamper with safety devices. Check their proper operation regularly.
- Keep machine free of grass, leaves, or other debris build-up. Clean oil or fuel spillage. Allow machine to cool before storing.
- Stop and inspect the equipment if you strike an object. Repair, if necessary, before restarting.
- Never make adjustments or repairs with the engine running.
- Grass catcher components are subject to wear, damage, and deterioration, which could expose moving parts or allow objects to be thrown. Frequently check components and replace with manufacturer's recommended parts, when necessary.
- Mower blades are sharp and can cut. Wrap the blade(s) or wear gloves, and use extra caution when servicing them.
- Check brake operation frequently. Adjust and service as required.

SAFETY RULES



- Be sure the area is clear of other people before mowing. Stop machine if anyone enters the area.
- Never carry passengers or children even with the blades off.
- Do not mow in reverse unless absolutely necessary. Always look down and behind before and while backing.
- Never carry children. They may fall off and be seriously injured or interfere with safe machine operation.
- Keep children out of the mowing area and under the watchful care of another responsible adult.
- Be alert and turn machine off if children enter the area.
- Before and when backing, look behind and down for small children.
- Mow up and down slopes (15° Max), not across.
- Remove obstacles such as rocks, tree limbs, etc.
- Watch for holes, ruts, or bumps. Uneven terrain could overturn the machine. Tall grass can hide obstacles.
- Use slow speed. Choose a low gear so that you will not have to stop or shift while on the slope.
- Avoid starting or stopping on a slope. If tires lose traction, disengage the blades and proceed slowly straight down the slope.
- If machine stops while going uphill, disengage blades, shift into reverse and back down slowly.
- Do not turn on slopes unless necessary, and then, turn slowly and gradually downhill, if possible.

PRODUCT SPECIFICATIONS

Gasoline Capacity and Type:	3.5 Gallons Unleaded Regular	
Oil Type: (API-SF-SJ):	SAE 10W30 (above 32°F) SAE 5W-30 (below 32°F)	
Oil Capacity:	W/ Filter:	4.5 Pints
	W/O Filter:	4.0 Pints
Spark Plug: (Gap: .030")	Champion RC12YC	
Ground Speed (MPH):		
Forward:	Hi:	Lo:
	0.7	1.7
	1.4	3.3
	2.3	5.4
Reverse:	0.9	2.1
Tire Pressure:	Front:	14 PSI
	Rear:	10 PSI
Charging System:	15 Amps @ 3600RPM	
Battery:	Amp/Hr:	35
	Min. CCA:	280
	Case Size:	U1R
Blade Bolt Torque:	45-55 Ft. Lbs.	

CONGRATULATIONS on your purchase of a new tractor. It has been designed, engineered and manufactured to give you the best possible dependability and performance.

Should you experience any problem you cannot easily remedy, please contact a Sears or other qualified service center. We have competent, well-trained technicians and the proper tools to service or repair this tractor.

Please read and retain this manual. The instructions will enable you to assemble and maintain your tractor properly. Always observe the "SAFETY RULES".

REPAIR AGREEMENT

A Repair Agreement is available on this product. Contact your nearest Sears store for details.

CUSTOMER RESPONSIBILITIES

- Read and observe the safety rules.
- Follow a regular schedule in maintaining, caring for and using your tractor.
- Follow the instructions under "Maintenance" and "Storage" sections of this owner's manual.

⚠WARNING: This tractor is equipped with an internal combustion engine and should not be used on or near any unimproved forest-covered, brush-covered or grass-covered land unless the engine's exhaust system is equipped with a spark arrester meeting applicable local or state laws (if any). If a spark arrester is used, it should be maintained in effective working order by the operator.

In the state of California the above is required by law (Section 4442 of the California Public Resources Code). Other states may have similar laws. Federal laws apply on federal lands. A spark arrester for the muffler is available through your nearest Sears service center (See REPAIR PARTS section of this manual).

UNASSEMBLED PARTS

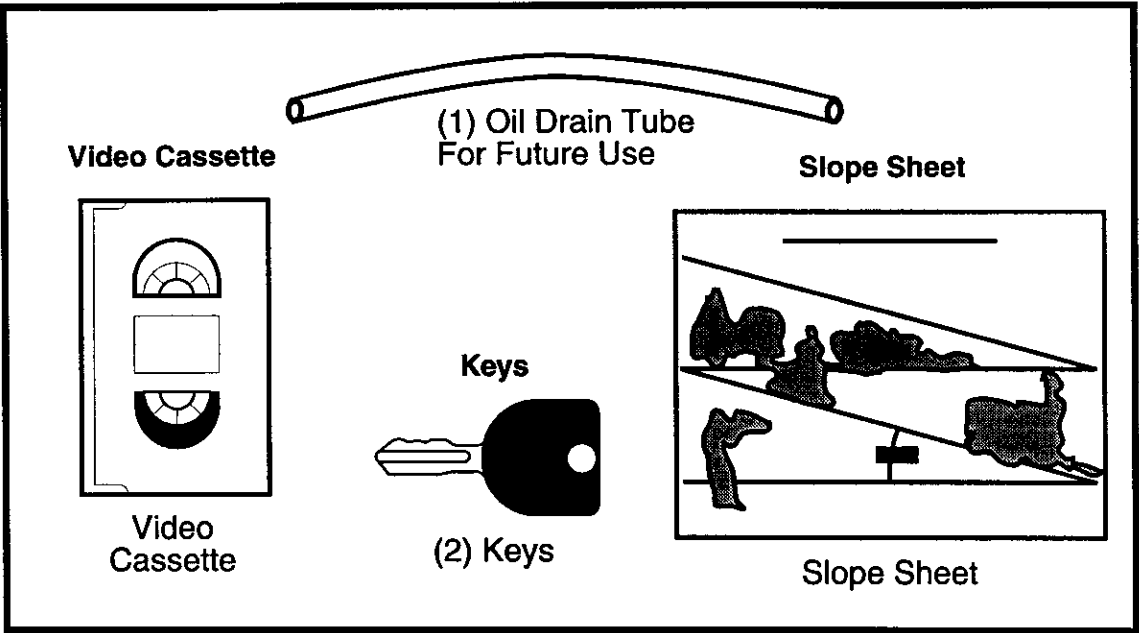

ASSEMBLY

Your new tractor has been assembled at the factory. Review the video cassette before you begin.

When right or left hand is mentioned in this manual, it means, from your point of view, when you are in the operating position (seated behind the steering wheel).

TO REMOVE TRACTOR FROM CARTON

UNPACK CARTON

1. Cut, from top to bottom, along lines on all four corners of carton, and lay panels flat.
2. Remove packing materials.
3. Remove protective materials from tractor hood and grille.

IMPORTANT: Check for and remove any staples in skid that may puncture tires where tractor is to roll off skid.

CHECK BATTERY

1. Lift hood to raised position.

NOTE: If this battery is put into service after month and year indicated on label (label located between terminals) charge battery for minimum of one hour at 6-10 amps. (See "BATTERY" in Maintenance section of this manual for charging instructions).

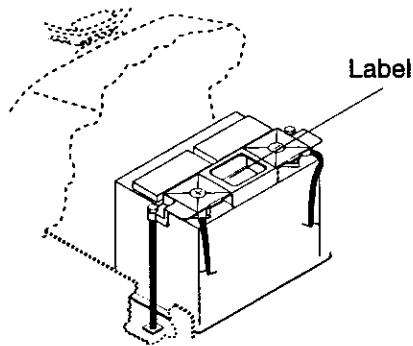

ADJUST SEAT

1. Raise seat and loosen adjustment knobs.
2. Lower seat into operating position and sit in seat.
3. Slide seat until a comfortable position is reached which allows you to press clutch/brake pedal all the way down.
4. Get off seat without moving its adjusted position.
5. Raise seat and tighten adjustment knob securely.

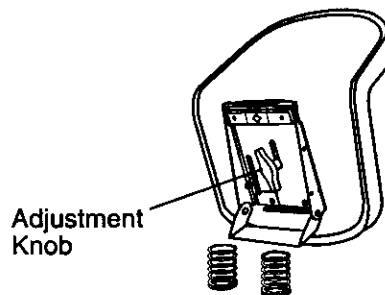

NOTE: You may now roll or drive your tractor off the skid. Follow the appropriate instruction below to remove the tractor from the skid.

TO ROLL TRACTOR OFF SKID (See Operation section for location and function of controls)

1. Press lift lever plunger and raise attachment lift lever to its highest position.
2. Release parking brake by depressing clutch/brake pedal.
3. Place gearshift lever in neutral (N) position.
4. Roll tractor forward off skid.

TO DRIVE TRACTOR OFF SKID (See Operation section for location and function of controls)

WARNING: Before starting, read, understand and follow all instructions in the Operation section of this manual. Be sure tractor is in a well-ventilated area. Be sure the area in front of tractor is clear of other people and objects.

1. Be sure all the above assembly steps have been completed.
2. Check engine oil level and fill fuel tank with gasoline.
3. Sit on seat in operating position, depress clutch/brake pedal and set the parking brake.
4. Place gear shift lever in neutral (N) position.
5. Press lift lever plunger and raise attachment lift lever to its highest position.
6. Start the engine. After engine has started, move throttle control to idle position.

7. Depress clutch/brake pedal into full "BRAKE" position and hold. Move gearshift lever to 1st gear.
8. Slowly release clutch/brake pedal and slowly drive tractor off skid.
9. Apply brake to stop tractor, set parking brake and place gearshift lever in neutral position.
10. Turn ignition key to "STOP" position. Continue with the instructions that follow.

CHECK TIRE PRESSURE

The tires on your tractor were overinflated at the factory for shipping purposes. Correct tire pressure is important for best cutting performance.

- Reduce tire pressure to PSI shown in "PRODUCT SPECIFICATIONS" section of this manual.

CHECK MOWER LEVELNESS

For best cutting results, mower should be properly leveled. See "TO LEVEL MOWER HOUSING" in the Service and Adjustments section of this manual.

CHECK FOR PROPER POSITION OF ALL BELTS

See the figures that are shown for replacing motion, mower drive, and mower blade drive belts in the Service and Adjustments section of this manual. Verify that the belts are routed correctly.

CHECK BRAKE SYSTEM

After you learn how to operate your tractor, check to see that the brake is properly adjusted. See "TO ADJUST BRAKE" in the Service and Adjustments section of this manual.

✓CHECKLIST

Before you operate and enjoy your new tractor, we wish to assure that you receive the best performance and satisfaction from this quality product.

Please review the following checklist:

- ✓ All assembly instructions have been completed.
- ✓ No remaining loose parts in carton.
- ✓ Battery is properly prepared and charged. (Minimum 1 hour at 6 amps).
- ✓ Seat is adjusted comfortably and tightened securely.
- ✓ All tires are properly inflated. (For shipping purposes, the tires were overinflated at the factory).
- ✓ Be sure mower deck is properly leveled side-to-side/front-to-rear for best cutting results. (Tires must be properly inflated for leveling).
- ✓ Check mower and drive belts. Be sure they are routed properly around pulleys and inside all belt keepers.
- ✓ Check wiring. See that all connections are still secure and wires are properly clamped.

While learning how to use your tractor, pay extra attention to the following important items:

- ✓ Engine oil is at proper level.
- ✓ Fuel tank is filled with fresh, clean, regular unleaded gasoline.
- ✓ Become familiar with all controls - their location and function. Operate them before you start the engine.
- ✓ Be sure brake system is in safe operating condition.

OPERATION

These symbols may appear on your tractor or in literature supplied with the product. Learn and understand their meaning.

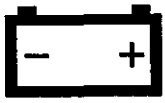

BATTERY



CAUTION OR WARNING



REVERSE



FORWARD



FAST



SLOW



ENGINE ON



ENGINE OFF



OIL PRESSURE

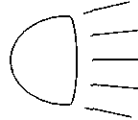

LIGHTS ON



OVER TEMP LIGHT

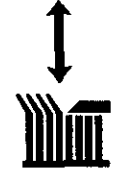

MOWER LIFT



FUEL



CHOKE



MOWER HEIGHT



PARKING BRAKE LOCKED



UNLOCKED



ATTACHMENT CLUTCH ENGAGED



REVERSE



NEUTRAL



HIGH



LOW



PARKING BRAKE



IGNITION



ATTACHMENT CLUTCH DISENGAGED



KEEP AREA CLEAR



SLOPE HAZARDS



(SEE SAFETY RULES SECTION)



DANGER, KEEP HANDS AND FEET AWAY

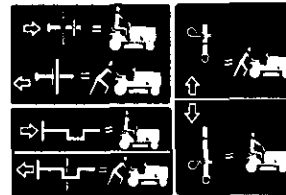

FREE WHEEL
(Automatic Models only)

KNOW YOUR TRACTOR

READ THIS OWNER'S MANUAL AND SAFETY RULES BEFORE OPERATING YOUR TRACTOR

Compare the illustrations with your tractor to familiarize yourself with the locations of various controls and adjustments. Save this manual for future reference.

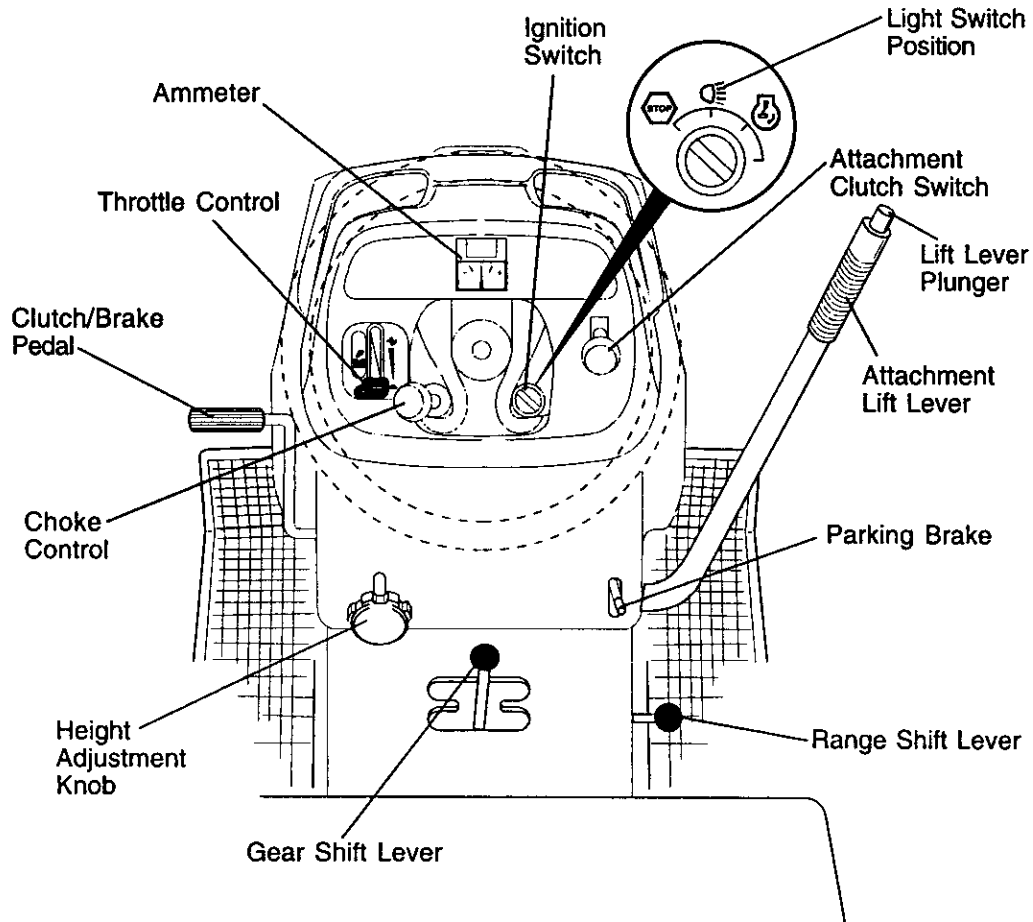

Our tractors conform to the safety standards of the American National Standards Institute.

ATTACHMENT CLUTCH SWITCH: Used to engage the mower blades, or other attachments mounted to your tractor.

LIGHT SWITCH POSITION: Turns the headlights on and off.

THROTTLE CONTROL: Used to control engine speed.

CLUTCH/BRAKE PEDAL: Used for declutching and braking the tractor and starting the engine.

CHOKE CONTROL: Used when starting a cold engine.

HEIGHT ADJUSTMENT KNOB: Used to adjust the mower cutting height.

GEARSHIFT LEVER: Selects the speed and direction of the tractor.

RANGESHIFT LEVER: Allows high (H) and low (L) speed for all forward and reverse gears.

ATTACHMENT LIFT LEVER: Used to raise and lower the mower deck or other attachments mounted to your tractor.

LIFT LEVER PLUNGER: Used to release attachment lift lever when changing its position.

IGNITION SWITCH: Used for starting and stopping the engine.

AMMETER: Indicates battery charging (+) or discharging (-).

PARKING BRAKE: Locks clutch/brake into the brake position.



The operation of any tractor can result in foreign objects thrown into the eyes, which can result in severe eye damage. Always wear safety glasses or eye shields while operating your tractor or performing any adjustments or repairs. We recommend standard safety glasses or a wide vision safety mask worn over spectacles.

HOW TO USE YOUR TRACTOR TO SET PARKING BRAKE

Your tractor is equipped with an operator presence sensing switch. When engine is running, any attempt by the operator to leave the seat without first setting the parking brake will shut off the engine.

1. Depress clutch/brake pedal all the way down and hold.
2. Pull parking brake lever up and release pressure from clutch/brake pedal. Pedal should remain in brake position. Make sure parking brake will hold tractor secure.

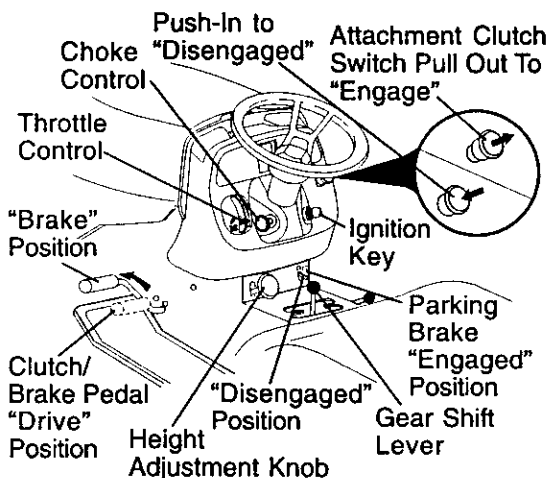

STOPPING

MOWER BLADES -

- To stop mower blades, push attachment clutch switch in to disengaged position.

GROUND DRIVE -

- To stop ground drive, depress clutch/brake pedal all the way down.
- Move gearshift lever to neutral (N) position.

ENGINE -

- Move throttle control to slow position.
- NOTE:** Failure to move throttle control to slow position to allow engine to idle before stopping may cause engine to "backfire".
- Turn ignition key to "STOP" position and remove key. Always remove key when leaving tractor to prevent unauthorized use.

- Never use choke to stop engine.
- IMPORTANT:** Leaving the ignition switch in any position other than "STOP" will cause the battery to discharge and go dead.

NOTE: Under certain conditions when tractor is standing idle with the engine running, hot engine exhaust gases may cause "browning" of grass. To eliminate this possibility, always stop engine when stopping tractor on grass areas.

CAUTION: Always stop tractor completely, as described above, before leaving the operator's position.

TO USE THROTTLE CONTROL

Always operate engine at full throttle.

- Operating engine at less than full throttle reduces the battery charging rate.
- Full throttle offers the best mower performance.

TO USE CHOKE CONTROL

Use choke control whenever you are starting a cold engine. Do not use to start a warm engine.

- To engage choke control, pull knob out. Slowly push knob in to disengage.

TO MOVE FORWARD AND BACKWARD

The direction and speed of movement is controlled by the gearshift lever.

1. Start tractor with clutch/brake pedal depressed and gearshift lever in neutral (N) position.
2. Move gearshift and range shift levers to desired position.
3. Slowly release clutch/brake pedal to start movement.

IMPORTANT: Bring tractor to a complete stop before shifting or changing gears. Failure to do so will shorten the useful life of your transaxle.

TO ADJUST MOWER CUTTING HEIGHT

The cutting height is controlled by turning the height adjustment knob in desired direction.

- Turn knob clockwise (↻) to raise cutting height.

- Turn knob counterclockwise (↺) to lower cutting height. The cutting height range is approximately 1-1/2" to 4-1/2". The heights are measured from the ground to the blade tip with the engine not running. These heights are approximate and may vary depending upon soil conditions, height of grass and types of grass being mowed.
- The average lawn should be cut to approximately 2-1/2 inches during the cool season and to over 3 inches during hot months. For healthier and better looking lawns, mow often and after moderate growth.
- For best cutting performance, grass over 6 inches in height should be mowed twice. Make the first cut relatively high; the second to desired height.

TO ADJUST GAUGE WHEELS

Gauge wheels are properly adjusted when they are slightly off the ground when mower is at the desired cutting height in operating position. Gauge wheels then keep the deck in proper position to help prevent scalping in most terrain conditions.

NOTE: Be sure tractor is on a flat level surface.

1. Lower mower and adjust mower to desired cutting height.
2. Remove retainer spring and clevis pin which secure each gauge wheel bar.
3. Lower gauge wheels to ground. Raise gauge wheels slightly to align holes in bracket and gauge wheel bar and insert clevis pin. Gauge wheels should be slightly off the ground.
4. Replace retainer spring into clevis pin.
5. Be sure all gauge wheels are in the same setting.

IMPORTANT: Be sure to readjust gauge wheels if you change the cutting height of the mower deck.

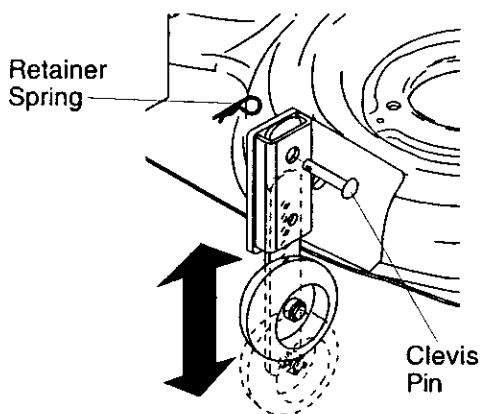

TO OPERATE MOWER

Your tractor is equipped with an operator presence sensing switch. Any attempt by the operator to leave the seat with the engine running and the attachment clutch engaged will shut off the engine.

1. Select desired height of cut.
2. Lower mower with attachment lift control.
3. Start mower blades by engaging attachment clutch control.

TO STOP MOWER BLADES - disengage attachment clutch control.

CAUTION: Do not operate the mower without either the entire grass catcher, on mowers so equipped, or the deflector shield in place.

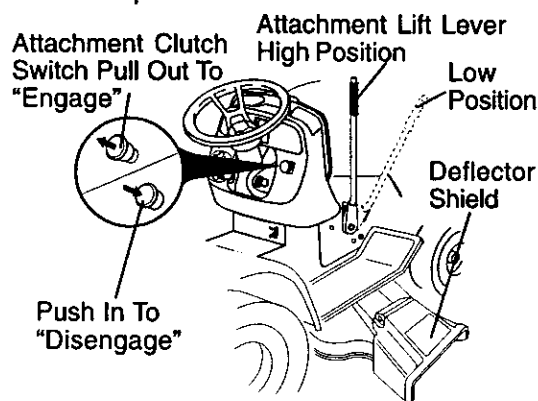

TO OPERATE ON HILLS

CAUTION: Do not drive up or down hills with slopes greater than 15° and do not drive across any slope. Use the slope guide provided at the back of this manual.

- Choose the slowest speed before starting up or down hills.
- Avoid stopping or changing speed on hills.
- If slowing is necessary, move throttle control lever to slower position.
- If stopping is absolutely necessary, push clutch/brake pedal quickly to brake position and engage parking brake.
- Move gearshift lever to 1st gear and range shift lever to low (L) position. Be sure you have allowed room for tractor to roll slightly as you restart movement.
- To restart movement, slowly release parking brake and clutch/brake pedal.
- Make all turns slowly.

TO TRANSPORT

- Raise attachment lift to highest position with attachment lift control.
- When pushing or towing your tractor, be sure gearshift lever is in neutral (N) position.
- Do not push or tow tractor at more than five (5) MPH.

NOTE: To protect hood from damage when transporting your tractor on a truck or a trailer, be sure hood is closed and secured to tractor. Use an appropriate means of tying hood to tractor (rope, cord, etc.).

TOWING CARTS AND OTHER ATTACHMENTS

Tow only the attachments that are recommended by and comply with specifications of the manufacturer of your tractor. Use common sense when towing. Too heavy of a load, while on a slope, is dangerous. Tires can lose traction with the ground and cause you to lose control of your tractor.

BEFORE STARTING THE ENGINE CHECK ENGINE OIL LEVEL

The engine in your tractor has been shipped, from the factory, already filled with summer weight oil.

1. Check engine oil with tractor on level ground.
 2. Unthread and remove oil fill cap/dipstick; wipe oil off. Reinsert the dipstick into the tube and rest oil fill cap on the tube. Do not thread the cap onto the tube. Remove and read oil level. If necessary, add oil until "FULL" mark on dipstick is reached. Do not overfill.
- For cold weather operation you should change oil for easier starting (See "OIL VISCOSITY CHART" in the Maintenance section of this manual).
 - To change engine oil, see the Maintenance section in this manual.

ADD GASOLINE

- Fill fuel tank to bottom of filler neck. Do not overfill. Use fresh, clean, regular unleaded gasoline with a minimum of 87 octane. (Use of leaded gasoline will increase carbon and lead oxide deposits and reduce valve life). Do not mix oil with gasoline. Purchase fuel in quantities that can be used within 30 days to assure fuel freshness.

CAUTION: Wipe off any spilled oil or fuel. Do not store, spill or use gasoline near an open flame.

IMPORTANT: When operating in temperatures below 32°F (0°C), use fresh, clean winter grade gasoline to help insure good cold weather starting.

CAUTION: Alcohol blended fuels (called gasohol or using ethanol or methanol) can attract moisture which leads to separation and formation of acids during storage. Acidic gas can damage the fuel system of an engine while in storage. To avoid engine problems, the fuel system should be emptied before storage of 30 days or longer. Drain the gas tank, start the engine and let it run until the fuel lines and carburetor are empty. Use fresh fuel next season. See Storage Instructions for additional information. Never use engine or carburetor cleaner products in the fuel tank or permanent damage may occur.

TO START ENGINE

When starting the engine for the first time or if the engine has run out of fuel, it will take extra cranking time to move fuel from the tank to the engine.

1. Sit on seat in operating position, depress clutch/brake pedal and set parking brake.
2. Place gear shift lever in neutral (N) position.
3. Move attachment clutch to disengaged position.
4. Move throttle control to fast position
5. Pull choke control out for a cold engine start attempt. For a warm engine start attempt the choke control may not be needed.

NOTE: Before starting, read the warm and cold starting procedures below.

6. Insert key into ignition and turn key clockwise to start position and release key as soon as engine starts. Do not run starter continuously for more than fifteen seconds per minute. If the engine does not start after several attempts, push choke control in, wait a few minutes and try again. If engine still does not start, pull the choke control out and retry.

WARM WEATHER STARTING (50° F and above)

7. When engine starts, slowly push choke control in until the engine begins to run smoothly. If the engine starts to run roughly, pull the choke control out slightly for a few seconds and then continue to push the control in slowly.

- The attachments and ground drive can now be used. If the engine does not accept the load, restart the engine and allow it to warm up for one minute using the choke as described above.

COLD WEATHER STARTING (50° F and below)

7. When engine starts, slowly push choke control in until the engine begins to run smoothly. Continue to push the choke control in small steps allowing the engine to accept small changes in speed and load, until the choke control is fully in. If the engine starts to run roughly, pull the choke control out slightly for a few seconds and then continue to push the control in slowly. This may require an engine warm-up period from several seconds to several minutes, depending on the temperature.

- The attachments can be used during the engine warm-up period and may require the choke control be pulled out slightly.

NOTE: If at a high altitude (above 3000 feet) or in cold temperatures (below 32 F) the carburetor fuel mixture may need to be adjusted for best engine performance (see "TO ADJUST CARBURETOR" in the Service and Adjustments section of this manual).

MOWING TIPS

- Tire chains cannot be used when the mower housing is attached to tractor.
- Mower should be properly leveled for best mowing performance. See "TO LEVEL MOWER HOUSING" in the Service and Adjustments section of this manual.
- The left hand side of mower should be used for trimming.
- Drive so that clippings are discharged onto the area that has been cut. Have the cut area to the right of the tractor. This will result in a more even distribution of clippings and more uniform cutting.
- When mowing large areas, start by turning to the right so that clippings will discharge away from shrubs, fences, driveways, etc. After one or two rounds, mow in the opposite direction making left hand turns until finished.

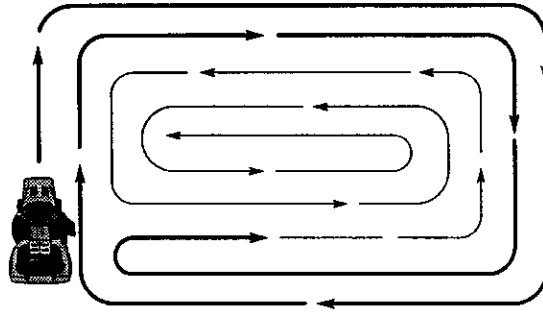

- If grass is extremely tall, it should be mowed twice to reduce load and possible fire hazard from dried clippings. Make first cut relatively high; the second to the desired height.
- Do not mow grass when it is wet. Wet grass will plug mower and leave undesirable clumps. Allow grass to dry before mowing.
- **Always operate engine at full throttle when mowing** to assure better mowing performance and proper discharge of material. Regulate ground speed by selecting a low enough gear to give the mower cutting performance as well as the quality of cut desired.
- When operating attachments, select a ground speed that will suit the terrain and give best performance of the attachment being used.

MAINTENANCE

MAINTENANCE SCHEDULE		BEFORE EACH USE	EVERY 8 HOURS	EVERY 25 HOURS	EVERY 50 HOURS	EVERY 100 HOURS	EVERY SEASON	BEFORE STORAGE	SERVICE DATES
T R A C T O R	Check Brake Operation	✓	✓						
	Check Tire Pressure	✓	✓						
	Check Operator Presence and Interlock Systems	✓							
	Check for Loose Fasteners	✓			✓ ⁵	✓			
	Sharpen/Replace Mower Blades			✓ ³					
	Lubrication Chart			✓			✓		
	Check Battery Level			✓ ⁴					
	Clean Battery and Terminals			✓			✓		
	Check Transaxle Cooling			✓					
	Check V-Belts				✓				
E N G I N E	Check Engine Oil Level	✓	✓						
	Change Engine Oil (with oil filter)			✓ ^{1,2}			✓		
	Change Engine Oil (without oil filter)			✓ ^{1,2}			✓		
	Clean Air Filter			✓ ²					
	Clean Air Screen			✓ ²					
	Inspect Muffler/Spark Arrester			✓					
	Replace Oil Filter (If equipped)				✓ ^{1,2}				
	Clean Engine Cooling Fins				✓ ²				
	Replace Spark Plug				✓		✓		
	Replace Air Filter Paper Cartridge				✓ ²				
Replace Fuel Filter						✓			

1 - Change more often when operating under a heavy load or in high ambient temperatures.
2 - Service more often when operating in dirty or dusty conditions.

3 - Replace blades more often when mowing in sandy soil.
4 - Not required if equipped with maintenance-free battery.
5 - Tighten front axle pivot bolt to 35 ft.-lbs. maximum. Do not overtighten.

GENERAL RECOMMENDATIONS

The warranty on this tractor does not cover items that have been subjected to operator abuse or negligence. To receive full value from the warranty, operator must maintain tractor as instructed in this manual. Some adjustments will need to be made periodically to properly maintain your tractor.

All adjustments in the Service and Adjustments section of this manual should be checked at least once each season.

- Once a year you should replace the spark plug, clean or replace air filter, and check blades and belts for wear. A new spark plug and clean air filter assure proper air-fuel mixture and help your engine run better and last longer.

BEFORE EACH USE

1. Check engine oil level.
2. Check brake operation.
3. Check tire pressure.
4. Check operator presence and interlock systems for proper operation.
5. Check for loose fasteners.

LUBRICATION CHART

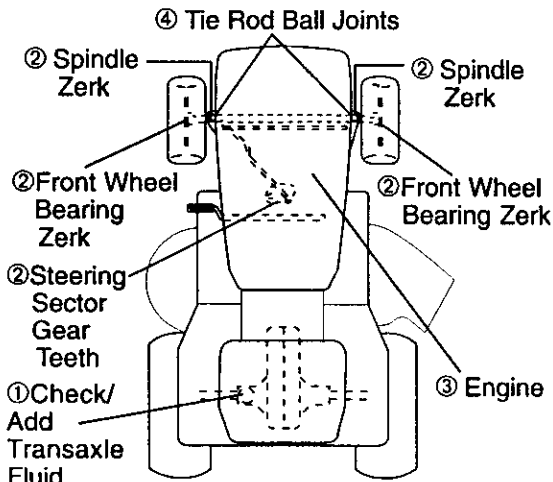

- ① SAE 30 or 10w30 motor oil
- ② General Purpose Grease
- ③ Refer to Maintenance "ENGINE" Section
- ④ Spray silicone lubricant (Move Boots to Lubricate)

IMPORTANT: Do not oil or grease the pivot points which have special nylon bearings. Viscous lubricants will attract dust and dirt that will shorten the life of the self-lubricating bearings. If you feel they must be lubricated, use only a dry, powdered graphite type lubricant sparingly.

TRACTOR

Always observe safety rules when performing any maintenance.

BRAKE OPERATION

If tractor requires more than six (6) feet stopping distance at high speed in highest gear, then brake must be adjusted. (See "TO ADJUST BRAKE" in the Service and Adjustments section of this manual).

TIRES

- Maintain proper air pressure in all tires (See "PRODUCT SPECIFICATIONS" section of this manual).
- Keep tires free of gasoline, oil, or insect control chemicals which can harm rubber.
- Avoid stumps, stones, deep ruts, sharp objects and other hazards that may cause tire damage.

NOTE: To seal tire punctures and prevent flat tires due to slow leaks, tire sealant may be purchased from your local parts dealer. Tire sealant also prevents tire dry rot and corrosion.

OPERATOR PRESENCE SYSTEM

Be sure operator presence and interlock systems are working properly. If your tractor does not function as described, repair the problem immediately.

- The engine should not start unless the clutch/brake pedal is fully depressed and attachment clutch control is in the disengaged position.
- When the engine is running, any attempt by the operator to leave the seat without first setting the parking brake should shut off the engine.
- When the engine is running and the attachment clutch is engaged, any attempt by the operator to leave the seat should shut off the engine.
- The attachment clutch should never operate unless the operator is in the seat.

BLADE CARE

For best results mower blades must be kept sharp. Replace bent or damaged blades.

BLADE REMOVAL

1. Raise mower to highest position to allow access to blades.

NOTE: Protect your hands with gloves and/or wrap blade with heavy cloth.

2. Remove blade bolt by turning counter-clockwise.

3. Install new or resharpened blade with stamped "THIS SIDE UP" facing deck and mandrel assembly.

IMPORTANT: To ensure proper assembly, center hole in blade must align with star on mandrel assembly.

4. Install and tighten blade bolt securely (45-55 Ft. Lbs. torque).

IMPORTANT: Special blade bolt is heat treated.

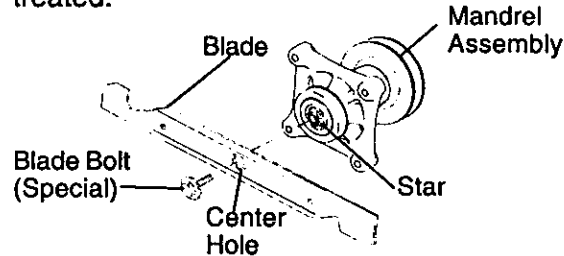

TO SHARPEN BLADE

NOTE: We do not recommend sharpening blade - but if you do, be sure the blade is balanced.

Care should be taken to keep the blade balanced. An unbalanced blade will cause excessive vibration and eventual damage to mower and engine.

- The blade can be sharpened with a file or on a grinding wheel. Do not attempt to sharpen while on the mower.
- To check blade balance, you will need a 5/8" diameter steel bolt, pin, or a cone balancer. (When using a cone balancer, follow the instructions supplied with balancer.)

NOTE: Do not use a nail for balancing blade. The lobes of the center hole may appear to be centered, but are not.

- Slide blade on to an unthreaded portion of the steel bolt or pin and hold the bolt or pin parallel with the ground. If blade is balanced, it should remain in a horizontal position. If either end of the blade moves downward, sharpen the heavy end until the blade is balanced.

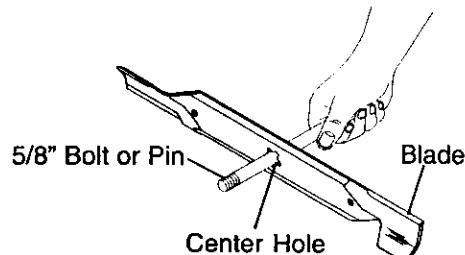

BATTERY

Your tractor has a battery charging system which is sufficient for normal use. However, periodic charging of the battery with an automotive charger will extend its life.

- Keep battery and terminals clean.
- Keep battery bolts tight.
- Keep small vent holes open.
- Recharge at 6-10 amperes for 1 hour.

NOTE: The original equipment battery on your tractor is maintenance free. Do not attempt to open or remove caps or covers. Adding or checking level of electrolyte is not necessary.

TO CLEAN BATTERY AND TERMINALS

Corrosion and dirt on the battery and terminals can cause the battery to "leak" power.

1. Remove terminal guard.
2. Disconnect **BLACK** battery cable first then **RED** battery cable and remove battery from tractor.
3. Rinse the battery with plain water and dry.
4. Clean terminals and battery cable ends with wire brush until bright.
5. Coat terminals with grease or petroleum jelly.
6. Reinstall battery (See "REPLACING BATTERY" in the SERVICE AND ADJUSTMENTS section of this manual).

TRANSAXLE COOLING

Keep transaxle free from build-up of dirt and chaff which can restrict cooling.

CHECK TRANSAXLE OIL LEVEL

1. Block up rear axle securely.
2. Remove left rear wheel by removing hub bolts.
3. Remove filler plug from transaxle. Oil level must be even with plug threads. If necessary, fill with SAE 30 motor oil, API SF-SJ. Replace filler plug.
4. Reassemble wheel to hub.

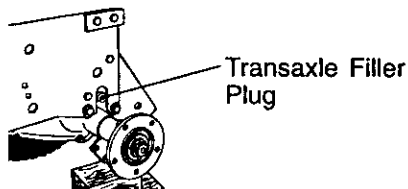

V-BELTS

Check V-belts for deterioration and wear after 100 hours of operation and replace if necessary. The belts are not adjustable. Replace belts if they begin to slip from wear.

ENGINE

LUBRICATION

Only use high quality detergent oil rated with API service classification SF-SJ. Select the oil's SAE viscosity grade according to your expected operating temperature.

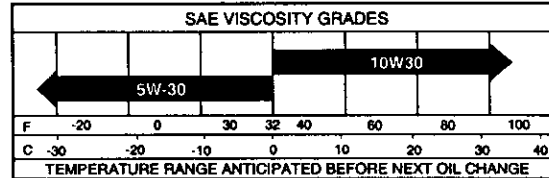

Change the oil after every 50 hours of operation or at least once a year if the tractor is not used for 50 hours in one year.

Check the crankcase oil level before starting the engine and after each eight (8) hours of operation. Tighten oil fill cap/dipstick securely each time you check the oil level.

TO CHANGE ENGINE OIL

Determine temperature range expected before oil change. All oil must meet API service classification SF-SJ.

- Be sure tractor is on level surface.
 - Oil will drain more freely when warm.
 - Catch oil in a suitable container.
1. Remove oil fill cap/dipstick. Be careful not to allow dirt to enter the engine when changing oil.
 2. Remove yellow cap from end of drain valve and install the drain tube onto the fitting.

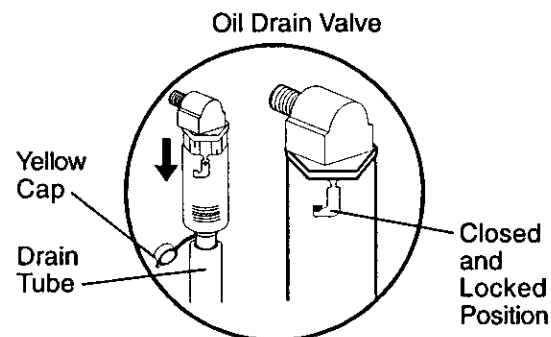

3. Unlock drain valve by pushing upward slightly and turning counterclockwise.
4. To open, pull down on the drain valve.
5. After oil has drained completely, close and lock the drain valve by pushing upward and turning clockwise until the pin is in the locked position as shown.
6. Remove the drain tube and replace the cap onto to the end of the drain valve.

7. Refill engine with oil through oil fill dipstick tube. Pour slowly. Do not overfill. For approximate capacity see "PRODUCT SPECIFICATIONS" section of this manual.
8. Use gauge on oil fill cap/dipstick for checking level. Insert dipstick into the tube and rest the oil fill cap on the tube. Do not thread the cap onto the tube when taking reading. Keep oil at "FULL" line on dipstick. Tighten cap onto the tube securely when finished.

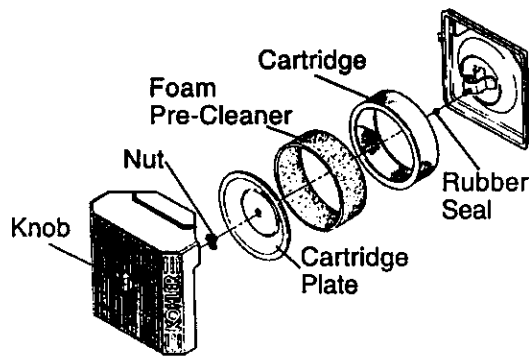

ENGINE OIL FILTER

Replace the engine oil filter every season or every other oil change if the tractor is used more than 100 hours in one year.

AIR FILTER

Your engine will not run properly using a dirty air filter. Clean the foam pre-cleaner after every 25 hours of operation or every season. Service paper cartridge every 100 hours of operation or every season, whichever occurs first.

Service air cleaner more often under dusty conditions.

1. Loosen knob and remove cover.

TO SERVICE PRE-CLEANER

2. Slide foam pre-cleaner off cartridge.
3. Wash it in liquid detergent and water.
4. Squeeze it dry in a clean cloth. Allow it to dry.
5. Saturate it in engine oil. Wrap it in clean, absorbent cloth and squeeze to remove excess oil.

TO SERVICE CARTRIDGE

- Replace a dirty, bent, or damaged cartridge.

NOTE: Do not wash the paper cartridge or use pressurized air, as this will damage the cartridge.

1. Remove nut and cartridge plate.
2. Reinstall the pre-cleaner (cleaned and oiled) over the paper cartridge.
3. Check rubber seal for damage and proper position around stud. Replace if necessary.
4. Reassemble air cleaner, cartridge plate, and nut.
5. Reinstall air cleaner cover and secure by tightening knob.

CLEAN AIR SCREEN

Air screen must be kept free of dirt and chaff to prevent engine damage from overheating. Clean with a wire brush or compressed air to remove dirt and stubborn dried gum fibers.

CLEAN AIR INTAKE/COOLING AREAS

To insure proper cooling, make sure the grass screen, cooling fins, and other external surfaces of the engine are kept clean at all times.

Every 100 hours of operation (more often under extremely dusty, dirty conditions), remove the blower housing and other cooling shrouds. Clean the cooling fins and external surfaces as necessary. Make sure the cooling shrouds are reinstalled.

NOTE: Operating the engine with a blocked grass screen, dirty or plugged cooling fins, and/or cooling shrouds removed will cause engine damage due to overheating.

MUFFLER

Inspect and replace corroded muffler and spark arrester (if equipped) as it could create a fire hazard and/or damage.

SPARK PLUG(S)

Replace spark plug(s) at the beginning of each mowing season or after every 100 hours of operation, whichever occurs first. Spark plug type and gap setting are shown in "PRODUCT SPECIFICATIONS" section of this manual.

IN-LINE FUEL FILTER

The fuel filter should be replaced once each season. If fuel filter becomes clogged, obstructing fuel flow to carburetor, replacement is required.

1. With engine cool, remove filter and plug fuel line sections.
2. Place new fuel filter in position in fuel line with arrow pointing towards carburetor.
3. Be sure there are no fuel line leaks and clamps are properly positioned.
4. Immediately wipe up any spilled gasoline.

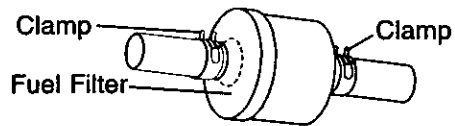

CLEANING

- Clean engine, battery, seat, finish, etc. of all foreign matter.
- Keep finished surfaces and wheels free of all gasoline, oil, etc.
- Protect painted surfaces with automotive type wax.

We do not recommend using a garden hose to clean your tractor unless the electrical system, muffler, air filter and carburetor are covered to keep water out. Water in engine can result in a shortened engine life.

SERVICE AND ADJUSTMENTS



WARNING: TO AVOID SERIOUS INJURY, BEFORE PERFORMING ANY SERVICE OR ADJUSTMENTS:

1. Depress clutch/brake pedal fully and set parking brake.
2. Place gearshift lever in neutral (N) position.
3. Place attachment clutch in "DISENGAGED" position.
4. Turn ignition key to "STOP" and remove key.
5. Make sure the blades and all moving parts have completely stopped.
6. Disconnect spark plug wire from spark plug and place wire where it cannot come in contact with plug.

TRACTOR

TO REMOVE MOWER

1. Place attachment clutch in "DISENGAGED" position.
2. If equipped, turn height adjustment knob to lowest setting.
3. Lower mower to its lowest position.
4. Remove retainer spring holding anti-sway bar to chassis bracket and disengage anti-sway bar from bracket.
5. Remove four retainer springs from front plate assembly and remove plate.
6. Remove retainer springs from suspension arms at deck and disengage arms from deck.
7. Raise attachment lift to its highest position.
8. Slide mower forward and remove belt from electric clutch pulley.
9. Slide mower out from under right side of tractor.

TO INSTALL MOWER

Be sure tractor is on level surface and mower suspension arms are raised with attachment lift control. Engage parking brake.

1. Swing anti-sway bar to left side of mower deck.
 2. Slide mower under tractor with deflector shield to right side of tractor.
- IMPORTANT:** Check belt for proper routing in all mower pulley grooves.
3. If equipped, turn height adjustment knob counterclockwise until it stops.
 4. Lower mower linkage with attachment lift control.
 5. Install belt into electric clutch pulley groove.
 6. Place the suspension arms on outward pointing deck pins. Retain with double loop retainer spring with loops up as shown.

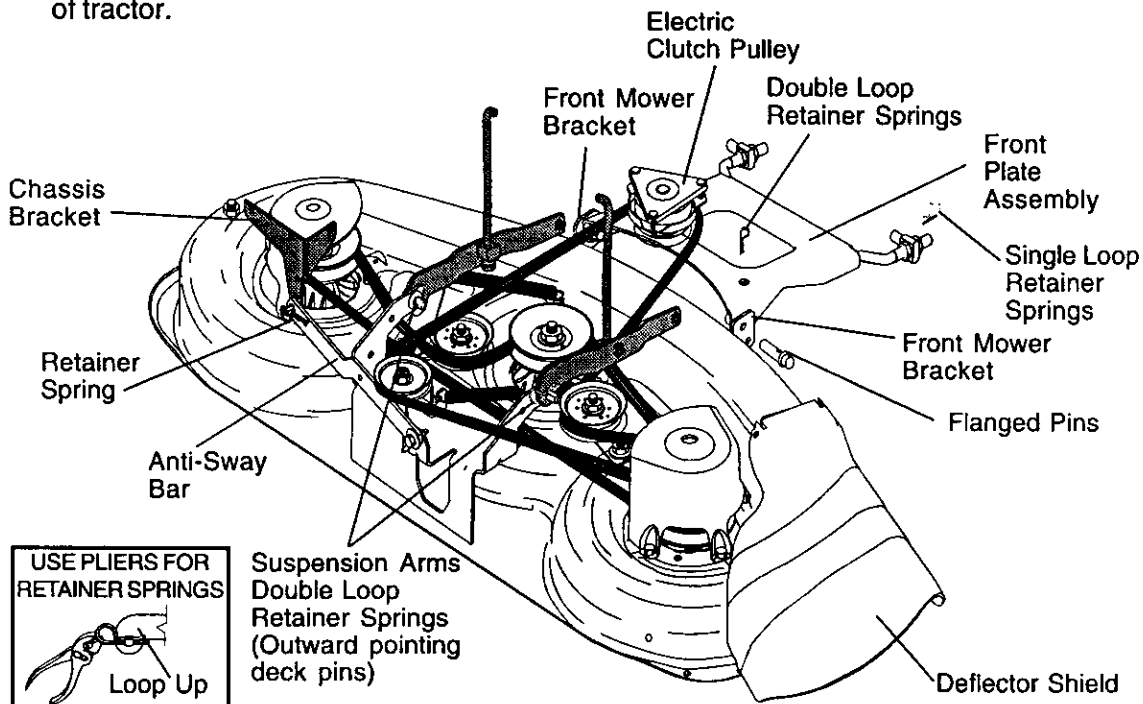

7. Install front plate assembly to tractor suspension brackets and retain with single loop retainer springs as shown.
8. Position front plate assembly between front mower brackets. Raise deck and plate assembly to align holes and insert flanged pins. Secure pins with double loop retainer springs between the plate and mower brackets.

NOTE: To assist in locating hole in flanged pin, the hole in pin is inline with notch on head of pin. If necessary, move mower side-to-side to give space between plate and mower brackets.

IMPORTANT: Check belt for proper routing in all mower pulley grooves.

9. Connect anti-sway bar to chassis bracket under left footrest and retain with double loop retainer spring.
10. If equipped, turn height adjustment knob clockwise to remove slack from mower suspension.
11. Raise deck to highest position.

TO LEVEL MOWER HOUSING

Adjust the mower while tractor is parked on level ground or driveway. Make sure tires are properly inflated (See "PRODUCT SPECIFICATIONS" section of this manual). If tires are over or underinflated, you will not properly adjust your mower.

SIDE-TO-SIDE ADJUSTMENT

- Raise mower to its highest position.
- Measure height from bottom edge of mower to ground level at front corners of mower. Distance "A" on both sides of mower should be the same.
- If adjustment is necessary, make adjustment on one side of mower only.
- To raise one side of mower, tighten lift link adjustment nut on that side.
- To lower one side of mower, loosen lift link adjustment nut on that side.

NOTE: Each full turn of adjustment nut will change mower height about 3/16".

- Recheck measurements after adjusting.

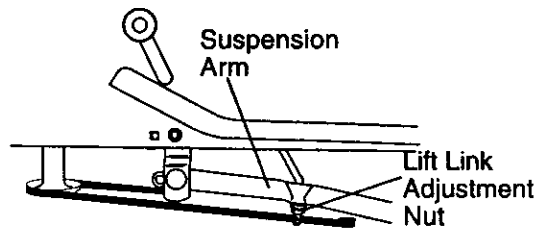
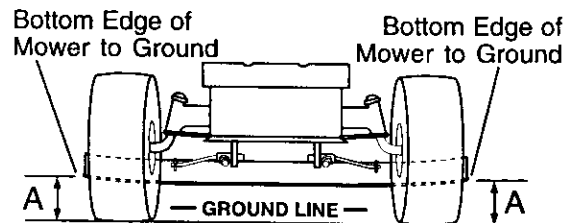

FRONT-TO-BACK ADJUSTMENT

IMPORTANT: Deck must be level side-to-side. If the following front-to-back adjustment is necessary, be sure to adjust both front links equally so mower will stay level side-to-side.

To obtain the best cutting results, the mower blades should be adjusted so the front tip is approximately 1/8" to 1/2" lower than the rear tip when the mower is in its highest position.

CAUTION: Blades are sharp. Protect your hands with gloves and/or wrap blade with heavy cloth.

Check adjustment on right side of tractor. Position any blade so the tip is pointing straight forward. Measure distance "B" at front and rear tip of blade

- Before making any necessary adjustments, check that both front plate links are equal in length.
- If links are not equal in length, adjust one link to same length as other link.
- To lower front of blade, loosen nut "C" on both front links an equal number of turns.

NOTE: Each full turn of nut "C" will change distance "B" by approximately 3/16".

- When distance "B" is 1/8" to 1/2" lower at front than rear, tighten nut "D" against trunnion on both front links.
- To raise front of blade, loosen nut "D" from trunnion on both front links. Tighten nut "C" on both front links an equal number of turns.
- When distance "B" is 1/8" to 1/2" lower at front than rear, tighten nut "D" against trunnion on both front links.
- Recheck side-to-side adjustment.

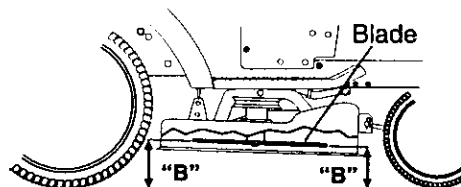

BOTH FRONT PLATE LINKS MUST BE EQUAL IN LENGTH

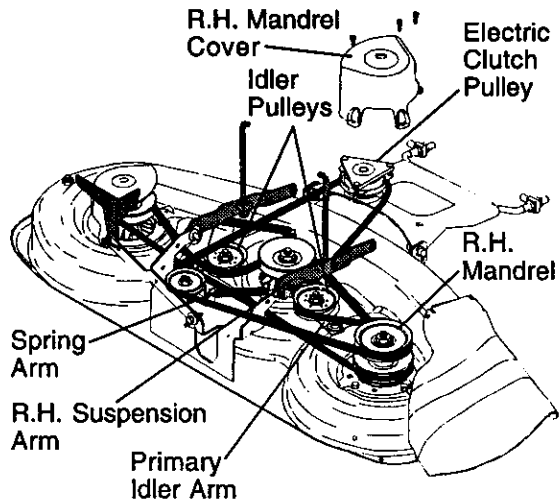
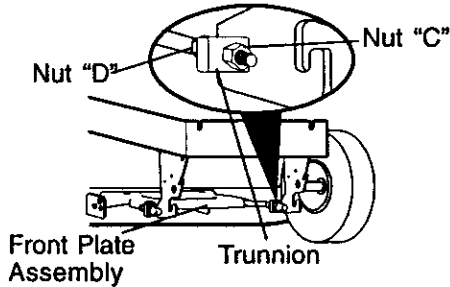
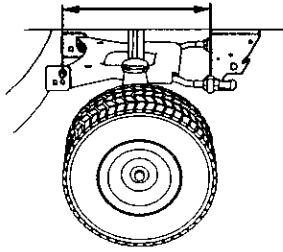

TO REPLACE MOWER BLADE (SECONDARY) DRIVE BELT

Park the tractor on level surface. Engage parking brake.

1. Remove mower (See "TO REMOVE MOWER" in this section of manual).
2. Remove screws from R.H. and L.H. mandrel covers and remove covers.

REMOVE MOWER DRIVE BELT

(Refer to "TO REMOVE MOWER DRIVE BELT" illustration in this section of manual).

3. Carefully roll belt over the top of R.H. mandrel pulley.
4. Remove belt from idler pulleys.
5. Check primary idler arm and two idlers to see that they rotate freely.
6. Be sure spring is securely hooked to primary idler arm and spring arm.

REMOVE MOWER BLADE (SECONDARY) DRIVE BELT

7. Carefully roll belt off L.H. mandrel pulley.
8. Remove belt from center mandrel pulley, idler pulley, and R.H. mandrel pulley.
9. Remove any dirt or grass which may have accumulated around mandrels and entire upper deck surface.
10. Check secondary idler arm and idler pulley to see that they rotate freely.
11. Be sure spring is hooked in secondary idler arm and secondary spring arm.

INSTALL NEW MOWER BLADE (SECONDARY) DRIVE BELT

12. Install new belt in lower groove of R.H. mandrel pulley, idler pulley, and center mandrel pulley as shown.
13. Carefully roll belt over L.H. mandrel pulley. Make sure belt is in all grooves properly.

TO REPLACE MOWER DRIVE BELT

MOWER DRIVE BELT REMOVAL

1. Park tractor on a level surface. Engage parking brake.
2. Lower mower to its lowest position.
3. Remove screws from R.H. mandrel cover and remove cover.
4. Remove any dirt or grass clippings which may have accumulated around mandrels and entire upper deck surface.
5. Disconnect R.H. suspension arm from rear deck bracket by removing retainer spring.
6. Carefully roll belt over the top of R.H. mandrel pulley.
7. Remove belt from electric clutch pulley.
8. Remove belt from idler pulleys.
9. Check primary idler arm and two idlers to see that they rotate freely.
10. Be sure spring is securely hooked to primary idler arm and spring arm.

MOWER DRIVE BELT INSTALLATION

11. Install belt in both idlers.
12. Install new belt onto electric clutch pulley.
13. Carefully roll belt into upper groove of R.H. mandrel pulley.
14. Carefully check belt routing making sure belt is in the grooves correctly.
15. Reconnect R.H. suspension arm to rear deck bracket with retainer spring.
16. Reassemble R.H. mandrel cover.

REINSTALL MOWER DRIVE BELT
(Refer to "TO REMOVE MOWER DRIVE BELT" illustration in this section of manual).

14. Install belt into upper groove of R.H. mandrel pulley and around both idlers. Pull belt to front of mower to remove slack.

15. Reinstall mandrel covers and securely tighten all screws.
 16. Carefully check belt routing making sure belt is in all grooves correctly.
 17. Reinstall mower to tractor (See "TO INSTALL MOWER" in this section of manual).

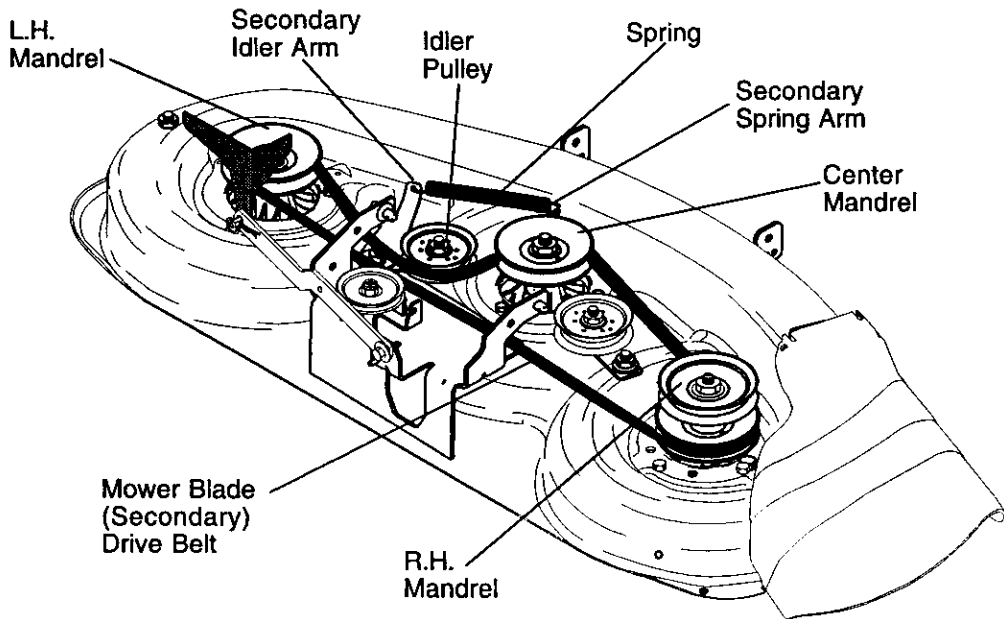

TO ADJUST ATTACHMENT CLUTCH

The electric clutch should provide years of service. The clutch has a built-in brake that stops the pulley within 5 seconds. Eventually, the internal brake will wear which may cause the mower blades to not engage, or, to not stop as required. Adjustments should be made by a Sears or other qualified service center.

1. Make sure attachment clutch and ignition switches are in "OFF" position.
2. Adjust the three nylon locknuts until space between clutch plate and rotor measures .012" at all three slot locations cut in the side of brake plate.

NOTE: After installing a new electric clutch, run tractor at full throttle and engage and disengage electric clutch 10 cycles to wear in clutch plate.

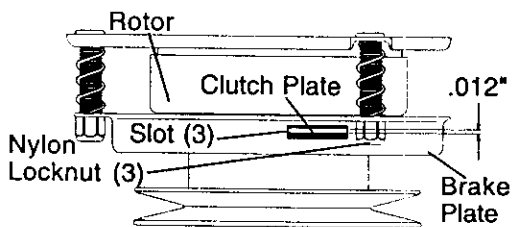

TO ADJUST BRAKE

Your tractor is equipped with an adjustable brake system which is mounted on the left side of the transaxle.

If tractor requires more than six (6) feet stopping distance at high speed in highest gear on a level dry concrete or paved surface, then brake must be adjusted.

1. Depress clutch/brake pedal and engage parking brake.
2. Measure distance between brake operating arm and nut "A" on brake rod.
3. If distance is other than 1-3/4", loosen jam nut and turn nut "A" until distance becomes 1-3/4". Retighten jam nut against nut "A".
4. Road test tractor for proper stopping distance as stated above. Readjust if necessary. If stopping distance is still greater than six (6) feet in highest gear, further maintenance is necessary. Contact a Sears or other qualified service center.

With parking brake "Engaged"

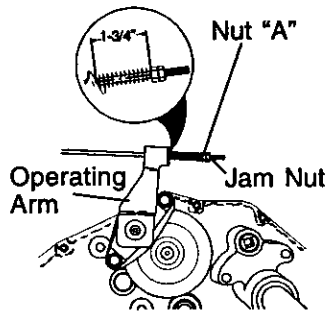

TO REPLACE MOTION DRIVE BELT

Park the tractor on level surface. Engage parking brake. For ease of service there is a belt installation guide decal on bottom of left footrest. It is not necessary to remove mower.

BELT REMOVAL -

1. Engage parking brake (creates slack in belt).
2. Remove mower drive belt from electric clutch pulley only (See "TO REPLACE MOWER DRIVE BELT" in this section of this manual).
3. Roll motion drive belt off transaxle pulley.
4. Roll belt off clutching idler pulleys, then off engine pulley and front V-idler pulley.
5. Pull belt out of all belt keepers.

BELT INSTALLATION -

1. Place V part of belt into grooves on engine pulley and front V-idler, making sure to route belt inside of belt keepers.
2. Put belt coming from V-idler above midspan belt keeper, then onto clutching idler pulleys as shown.
3. Make sure V part of belt engages V-idler.
4. Place belt around transaxle pulley, beginning at top. V part of belt should engage transaxle pulley.
5. Place long lower section of belt through loop in midspan belt keeper.
6. Check to be sure belt is on proper side of all belt keepers.
7. Reinstall mower drive belt onto electric clutch pulley.

IMPORTANT: Check Brake Adjustment.

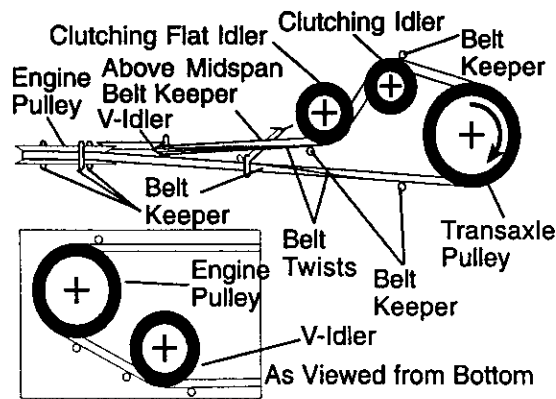

TO ADJUST STEERING WHEEL ALIGNMENT

If steering wheel crossbars are not horizontal (left to right) when wheels are positioned straight forward, remove steering wheel and reassemble per instructions in the Assembly section of this manual.

FRONT WHEEL TOE-IN ADJUSTMENT

Front wheel toe-in is required for proper steering operation. Toe-in was set at the factory and adjustment should not be necessary. If parts in the front axle or steering mechanism have been replaced or damaged, check toe-in and adjust if necessary.

TO CHECK TOE-IN -

1. Position front wheels straight ahead.
 2. Measure distance between wheels at front and rear of tires (dimensions "A" and "B").
- Front dimension "A" should be 1/8" to 1/4" less than rear dimension "B".

TO ADJUST TOE-IN -

1. Loosen jam nuts at adjustment sleeves on tie rod.
2. Adjust tie rod until dimension "A" is 1/8" to 1/4" less than dimension "B".
3. Tighten jam nuts securely.

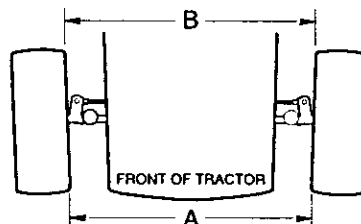

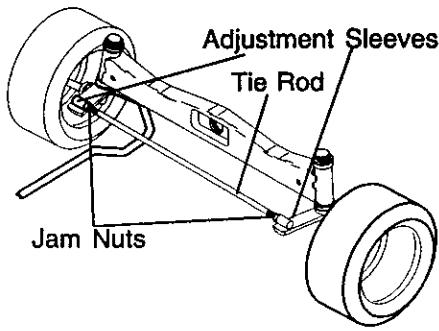

FRONT WHEEL CAMBER

The front wheel camber is not adjustable on your tractor. If damage has occurred to affect the front wheel camber, contact a Sears or other qualified service center

TO REMOVE WHEEL FOR REPAIRS

FRONT WHEEL -

1. Block up axle securely.
2. Remove axle cover, retaining ring and washers to allow wheel removal.
3. Repair tire and reassemble.
4. Replace washers and snap retaining ring securely in axle groove.
5. Replace axle cover.

REAR WHEEL -

1. Block rear axle securely.
2. Remove five (5) hub bolts to allow wheel removal.
3. Repair tire and reassemble. Replace and tighten hub bolts securely.

NOTE: To seal tire punctures and prevent flat tires due to slow leaks, purchase and use tire sealant from Sears. Tire sealant also prevents tire dry rot and corrosion.

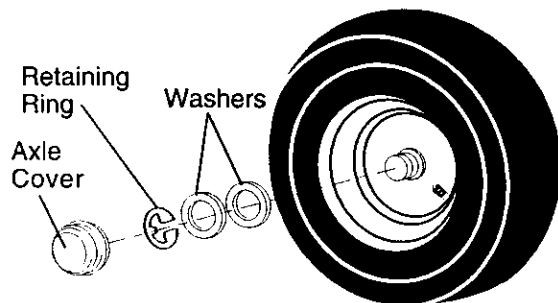

TO START ENGINE WITH A WEAK BATTERY

⚠WARNING: Lead-acid batteries generate explosive gases. Keep sparks, flame and smoking materials away from batteries. Always wear eye protection when around batteries.

If your battery is too weak to start the engine, it should be recharged. (See "BATTERY" in the MAINTENANCE section of this manual).

If "jumper cables" are used for emergency starting, follow this procedure:

IMPORTANT: Your tractor is equipped with a 12 volt system. The other vehicle must also be a 12 volt system. Do not use your tractor battery to start other vehicles.

TO ATTACH JUMPER CABLES -

1. Connect one end of the RED cable to the POSITIVE (+) terminal of each battery(A-B), taking care not to short against tractor chassis.
2. Connect one end of the BLACK cable to the NEGATIVE (-) terminal (C) of fully charged battery.
3. Connect the other end of the BLACK cable (D) to good chassis ground, away from fuel tank and battery.

TO REMOVE CABLES, REVERSE ORDER -

1. BLACK cable first from chassis and then from the fully charged battery.
2. RED cable last from both batteries.

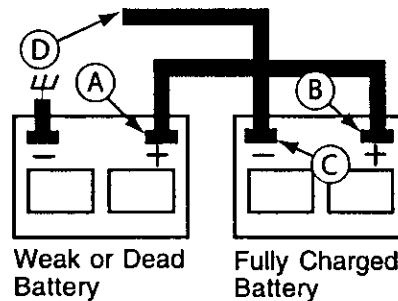

REPLACING BATTERY

⚠CAUTION: Do not short battery terminals by allowing a wrench or any other object to contact both terminals at the same time. Before connecting battery, remove metal bracelets, wristwatch bands, rings, etc.

Positive terminal must be connected first to prevent sparking from accidental grounding.

1. Lift hood to raised position.
2. Remove terminal guard.

3. Disconnect BLACK battery cable then RED battery cable and carefully remove battery from tractor.
4. Install new battery with terminals in same position as old battery.
5. Reinstall terminal guard.
6. First connect RED battery cable to positive (+) battery terminal with hex bolt and keps nut as shown. Tighten securely.
7. Connect BLACK grounding cable to negative (-) battery terminal with remaining hex bolt and keps nut. Tighten securely.
8. Close terminal access doors.
9. Close hood.

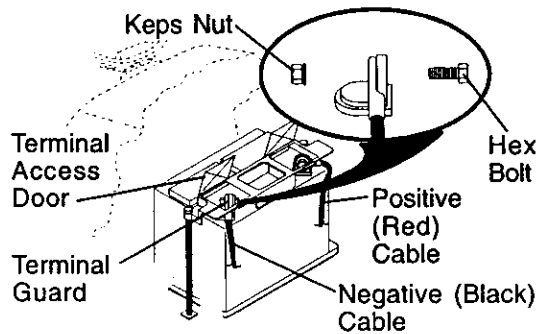
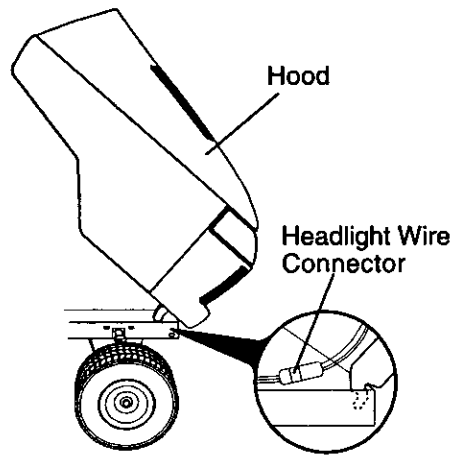

ENGINE

Maintenance, repair, or replacement of the emission control devices and systems, which are being done at the customer's expense, may be performed by any non-road engine repair establishment or individual. Warranty repairs must be performed by an authorized engine manufacturer's service outlet.

TO ADJUST THROTTLE CONTROL CABLE

The throttle control has been preset at the factory and adjustment should not be necessary. Check adjustment as described below before loosening cable. If adjustment is necessary, proceed as follows:

1. With engine not running, move throttle control lever to fast position.
2. Check that speed control lever is against stop screw. If it is not, loosen casing clamp screw and pull throttle cable until lever is against screw. Tighten clamp screw securely.

TO REPLACE HEADLIGHT BULB

1. Raise hood.
2. Pull bulb holder out of the hole in the backside of the grill.
3. Replace bulb in holder and push bulb holder securely back into the hole in the backside of the grill.
4. Close hood.

INTERLOCKS AND RELAYS

Loose or damaged wiring may cause your tractor to run poorly, stop running, or prevent it from starting.

- Check wiring. See electrical wiring diagram in the Repair Parts section.

TO REPLACE FUSE

Replace with 30 amp automotive-type plug-in fuse. The fuse holder is located behind the dash.

TO REMOVE HOOD AND GRILL ASSEMBLY

1. Raise hood.
2. Unsnap headlight wire connector.
3. Stand in front of tractor. Grasp hood at sides, tilt toward engine and lift off of tractor.
4. When replacing hood, be sure to reconnect the headlight wire connector.

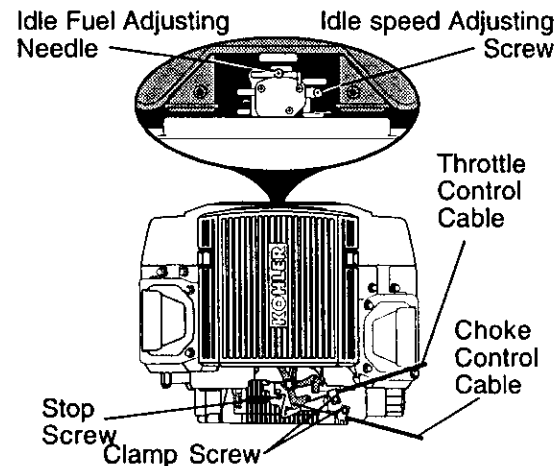

TO ADJUST CHOKE CONTROL

The choke control has been preset at the factory and adjustment should not be necessary. Check adjustment as described below before loosening cable. If adjustment is necessary, proceed as follows:

1. With engine not running, move choke control (located on dash panel) to full choke position.
2. Remove air cleaner cover, filter and cartridge plate to expose carburetor choke (See "AIR FILTER" in the Maintenance section of this manual).
3. Choke should be closed. If it is not, loosen casing clamp screw and move choke cable until choke is completely closed. Tighten casing clamp screw securely.
4. Reassemble air cleaner.

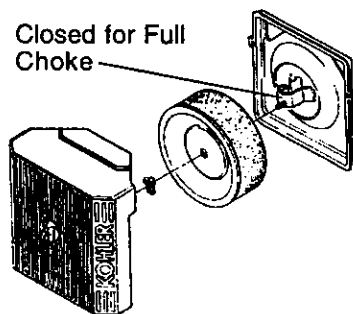

TO ADJUST CARBURETOR

The carburetor has been present at the factory and adjustment should not be necessary. However, minor adjustment may be required to compensate for differences in fuel, temperature, altitude or load. If the carburetor does need adjustment, proceed as follows:

In general, turning the adjusting needles **in** (clockwise) decreases the supply of fuel to the engine giving a leaner fuel/air mixture. Turning the adjusting needles **out** (counterclockwise) increases the supply of fuel to the engine giving a richer fuel/air mixture.

IMPORTANT: Damage to the needles and the seats in carburetor may result if screw is turned in too tight.

PRELIMINARY SETTING -

1. Be sure you have a clean air filter, and the throttle control cable is adjusted properly (see "TO ADJUST THROTTLE CONTROL CABLE" in the Service and Adjustments section of this manual).

2. With engine off turn idle fuel adjusting needle **in** (clockwise) closing it finger tight and then turn **out** (counterclockwise) 1 turn.

FINAL SETTING -

1. Start engine and allow to warm for five minutes. Make final adjustments with engine running and shift/motion control lever in neutral (N) position.

NOTE: The high idle is set at the factory and cannot be adjusted.

2. Idle speed setting - With throttle control lever in slow position, engine should idle at 1200 RPM. If engine idles too slow or fast, turn idle speed adjusting screw in or out until correct idle is attained.
3. Idle fuel needle setting - With throttle control lever in slow position, turn idle fuel adjusting needle **in** (clockwise) until engine speed decreases and then turn **out** (counterclockwise) approximately 3/4 turn to obtain the best low speed performance.
4. Recheck idle speed. Readjust if necessary.

ACCELERATION TEST -

5. Move throttle control lever from slow to fast position. If engine hesitates or dies, turn idle fuel adjusting needle **out** (counterclockwise) 1/8 turn. Repeat test and continue to adjust, if necessary, until engine accelerates smoothly.

High speed stop is factory adjusted. Do not adjust-damage may result.

IMPORTANT: Never tamper with the engine governor, which is factory set for proper engine speed. Overspeeding the engine above the factory high speed setting can be dangerous. If you think the engine-governed high speed needs adjusting, contact a Sears or other qualified service center, which has proper equipment and experience to make any necessary adjustments.

STORAGE

Immediately prepare your tractor for storage at the end of the season or if the tractor will not be used for 30 days or more.

CAUTION: Never store the tractor with gasoline in the tank inside a building where fumes may reach an open flame or spark. Allow the engine to cool before storing in any enclosure.

TRACTOR

Remove mower from tractor for winter storage. When mower is to be stored for a period of time, clean it thoroughly, remove all dirt, grease, leaves, etc. Store in a clean, dry area.

1. Clean entire tractor (See "CLEANING" in the Maintenance section of this manual).
2. Inspect and replace belts, if necessary (See belt replacement instructions in the Service and Adjustments section of this manual).
3. Lubricate as shown in the Maintenance section of this manual.
4. Be sure that all nuts, bolts and screws are securely fastened. Inspect moving parts for damage, breakage and wear. Replace if necessary.
5. Touch up all rusted or chipped paint surfaces; sand lightly before painting.

BATTERY

- Fully charge the battery for storage.
- After a period of time in storage, battery may require recharging.
- To help prevent corrosion and power leakage during long periods of storage, battery cables should be disconnected and battery cleaned thoroughly (see "TO CLEAN BATTERY AND TERMINALS" in the Maintenance section of this manual).
- After cleaning, leave cables disconnected and place cables where they cannot come in contact with battery terminals.
- If battery is removed from tractor for storage, do not store battery directly on concrete or damp surfaces.

ENGINE

FUEL SYSTEM

IMPORTANT: It is important to prevent gum deposits from forming in essential fuel system parts such as carburetor, fuel hose, or tank during storage. Also,

alcohol blended fuels (called gasohol or using ethanol or methanol) can attract moisture which leads to separation and formation of acids during storage. Acidic gas can damage the fuel system of an engine while in storage.

1. Drain the fuel tank.
 2. Start the engine and let it run until the fuel lines and carburetor are empty.
- Never use engine or carburetor cleaner products in the fuel tank or permanent damage may occur.
 - Use fresh fuel next season.

NOTE: Fuel stabilizer is an acceptable alternative in minimizing the formation of fuel gum deposits during storage. Add stabilizer to gasoline in fuel tank or storage container. Always follow the mix ratio found on stabilizer container. Run engine at least 10 minutes after adding stabilizer to allow the stabilizer to reach the carburetor. Do not drain the gas tank and carburetor if using fuel stabilizer.

ENGINE OIL

Drain oil (with engine warm) and replace with clean engine oil. (See "ENGINE" in the Maintenance section of this manual).

CYLINDER(S)

1. Remove spark plug(s).
2. Pour one ounce of oil through spark plug hole(s) into cylinder(s).
3. Turn ignition key to start position for a few seconds to distribute oil.
4. Replace with new spark plug(s).

OTHER

- Do not store gasoline from one season to another.
- Replace your gasoline can if your can starts to rust. Rust and/or dirt in your gasoline will cause problems.
- If possible, store your tractor indoors and cover it to give protection from dust and dirt.
- Cover your tractor with a suitable protective cover that does not retain moisture. Do not use plastic. Plastic cannot breathe which allows condensation to form and will cause your tractor to rust.

IMPORTANT: Never cover tractor while engine and exhaust areas are still warm.

TROUBLESHOOTING CHART:

See appropriate section in manual unless directed to Sears service center

PROBLEM	CAUSE	CORRECTION
Will not start	<ol style="list-style-type: none"> 1. Out of fuel. 2. Engine not "CHOKED" properly. 3. Engine flooded. 4. Bad spark plug. 5. Dirty air filter. 6. Dirty fuel filter. 7. Water in fuel. 8. Loose or damaged wiring. 9. Carburetor out of adjustment. 10. Engine valves out of adjustment. 	<ol style="list-style-type: none"> 1. Fill fuel tank. 2. See "TO START ENGINE" in Operation section. 3. Wait several minutes before attempting to start. 4. Replace spark plug. 5. Clean/replace air filter. 6. Replace fuel filter. 7. Drain fuel tank and carburetor, refill tank with fresh gasoline and replace fuel filter. 8. Check all wiring. 9. See "To Adjust Carburetor" in Service and Adjustments section. 10. Contact a Sears or other qualified service center.
Hard to start	<ol style="list-style-type: none"> 1. Dirty air filter. 2. Bad spark plug. 3. Weak or dead battery. 4. Dirty fuel filter. 5. Stale or dirty fuel. 6. Loose or damaged wiring. 7. Carburetor out of adjustment. 8. Engine valves out of adjustment. 	<ol style="list-style-type: none"> 1. Clean/replace air filter. 2. Replace spark plug. 3. Recharge or replace battery. 4. Replace fuel filter. 5. Drain fuel tank and refill with fresh gasoline. 6. Check all wiring. 7. See "To Adjust Carburetor" in Service and Adjustments section. 8. Contact a Sears or other qualified service center.
Engine will not turn over	<ol style="list-style-type: none"> 1. Clutch/brake pedal not depressed. 2. Attachment clutch is engaged. 3. Weak or dead battery. 4. Blown fuse. 5. Corroded battery terminals. 6. Loose or damaged wiring. 7. Faulty ignition switch. 8. Faulty solenoid or starter. 9. Faulty operator presence switch(es). 	<ol style="list-style-type: none"> 1. Depress clutch/brake pedal. 2. Disengage attachment clutch. 3. Recharge or replace battery. 4. Replace fuse. 5. Clean battery terminals. 6. Check all wiring. 7. Check/replace ignition switch. 8. Check/replace solenoid or starter. 9. Contact a Sears or other qualified service center.
Engine clicks but will not start	<ol style="list-style-type: none"> 1. Weak or dead battery. 2. Corroded battery terminals. 3. Loose or damaged wiring. 4. Faulty solenoid or starter. 	<ol style="list-style-type: none"> 1. Recharge or replace battery. 2. Clean battery terminals. 3. Check all wiring. 4. Check/replace solenoid or starter.

TROUBLESHOOTING CHART:

See appropriate section in manual unless directed to Sears service center

PROBLEM	CAUSE	CORRECTION
Loss of power	<ol style="list-style-type: none"> 1. Cutting too much grass/too fast. 2. Throttle in "CHOKE" position. 3. Build-up of grass, leaves and trash under mower. 4. Dirty air filter. 5. Low oil level/dirty oil. 6. Faulty spark plug. 7. Dirty fuel filter. 8. Stale or dirty fuel. 9. Water in fuel. 10. Spark plug wire loose. 11. Dirty engine air screen/fins. 12. Dirty/clogged muffler. 13. Loose or damaged wiring. 14. Carburetor out of adjustment. 15. Engine valves out of adjustment. 	<ol style="list-style-type: none"> 1. Set in "Higher Cut" position/ reduce speed. 2. Adjust throttle control. 3. Clean underside of mower housing. 4. Clean/replace air filter. 5. Check oil level/change oil. 6. Clean and regap or change spark plug. 7. Replace fuel filter. 8. Drain fuel tank and refill with fresh gasoline. 9. Drain fuel tank and carburetor, refill tank with fresh gasoline and replace fuel filter. 10. Connect and tighten spark plug wire. 11. Clean engine air screen/fins. 12. Clean/replace muffler. 13. Check all wiring. 14. See "To Adjust Carburetor" in Service and Adjustments section. 15. Contact a Sears or other qualified service center.
Excessive vibration	<ol style="list-style-type: none"> 1. Worn, bent or loose blade. 2. Bent blade mandrel. 3. Loose/damaged part(s). 	<ol style="list-style-type: none"> 1. Replace blade. Tighten blade bolt. 2. Contact a Sears or other qualified service center. 3. Tighten loose part(s). Replace damaged parts.
Engine continues to run when operator leaves seat with attachment clutch engaged	<ol style="list-style-type: none"> 1. Faulty operator-safety presence control system. 	<ol style="list-style-type: none"> 1. Check wiring, switches and connections. If not contact a Sears or other qualified service center.
Poor cut - uneven	<ol style="list-style-type: none"> 1. Worn, bent or loose blade. 2. Mower deck not level. 3. Buildup of grass, leaves, and trash under mower. 4. Bent blade mandrel. 5. Clogged mower deck vent holes from buildup of grass, leaves, and trash around mandrels. 	<ol style="list-style-type: none"> 1. Replace blade. Tighten blade bolt. 2. Level mower deck. 3. Clean underside of mower housing. 4. Contact a Sears or other qualified service center. 5. Clean around mandrels to open vent holes.

TROUBLESHOOTING CHART:

See appropriate section in manual unless directed to Sears service center

PROBLEM	CAUSE	CORRECTION
Mower blades will not rotate	<ol style="list-style-type: none">1. Obstruction in clutch mechanism.2. Worn/damaged mower drive belt.3. Frozen idler pulley.4. Frozen blade mandrel.	<ol style="list-style-type: none">1. Remove obstruction.2. Replace mower drive belt.3. Replace idler pulley.4. Contact a Sears or other qualified service center.
Poor grass discharge	<ol style="list-style-type: none">1. Engine speed too slow.2. Travel speed too fast.3. Wet grass.4. Mower deck not level.5. Low/uneven tire air pressure.6. Worn, bent or loose blade.7. Buildup of grass, leaves and trash under mower.8. Mower drive belt worn.9. Blades improperly installed.10. Improper blades used.11. Clogged mower deck vent holes from buildup of grass, leaves, and trash around mandrels.	<ol style="list-style-type: none">1. Place throttle control in "FAST" position.2. Shift to slower speed.3. Allow grass to dry before mowing.4. Level mower deck.5. Check tires for proper air pressure.6. Replace/sharpen blade. Tighten blade bolt.7. Clean underside of mower housing.8. Replace mower drive belt.9. Reinstall blades sharp edge down.10. Replace with blades listed in this manual.11. Clean around mandrels to open vent holes.
Headlight(s) not working (if so equipped)	<ol style="list-style-type: none">1. Switch is "OFF".2. Bulb(s) or lamp(s) burned out.3. Faulty light switch.4. Loose or damaged wiring.5. Blown fuse.	<ol style="list-style-type: none">1. Turn switch "ON".2. Replace bulb(s) or lamp(s).3. Check/replace light switch.4. Check wiring and connections.5. Replace fuse.
Battery will not charge	<ol style="list-style-type: none">1. Bad battery cell(s).2. Poor cable connections.3. Faulty regulator (if so equipped).4. Faulty alternator.	<ol style="list-style-type: none">1. Replace battery.2. Check/clean all connections.3. Replace regulator.4. Replace alternator.
Engine "backfires" when turning engine "OFF"	<ol style="list-style-type: none">1. Engine throttle control not set at "SLOW" position for 30 seconds before stopping engine.	<ol style="list-style-type: none">1. Move throttle control to "SLOW" position and allow to idle for 30 seconds before stopping engine.

TRACTOR -- MODEL NUMBER 917.275012

SCHEMATIC

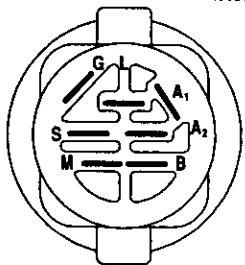
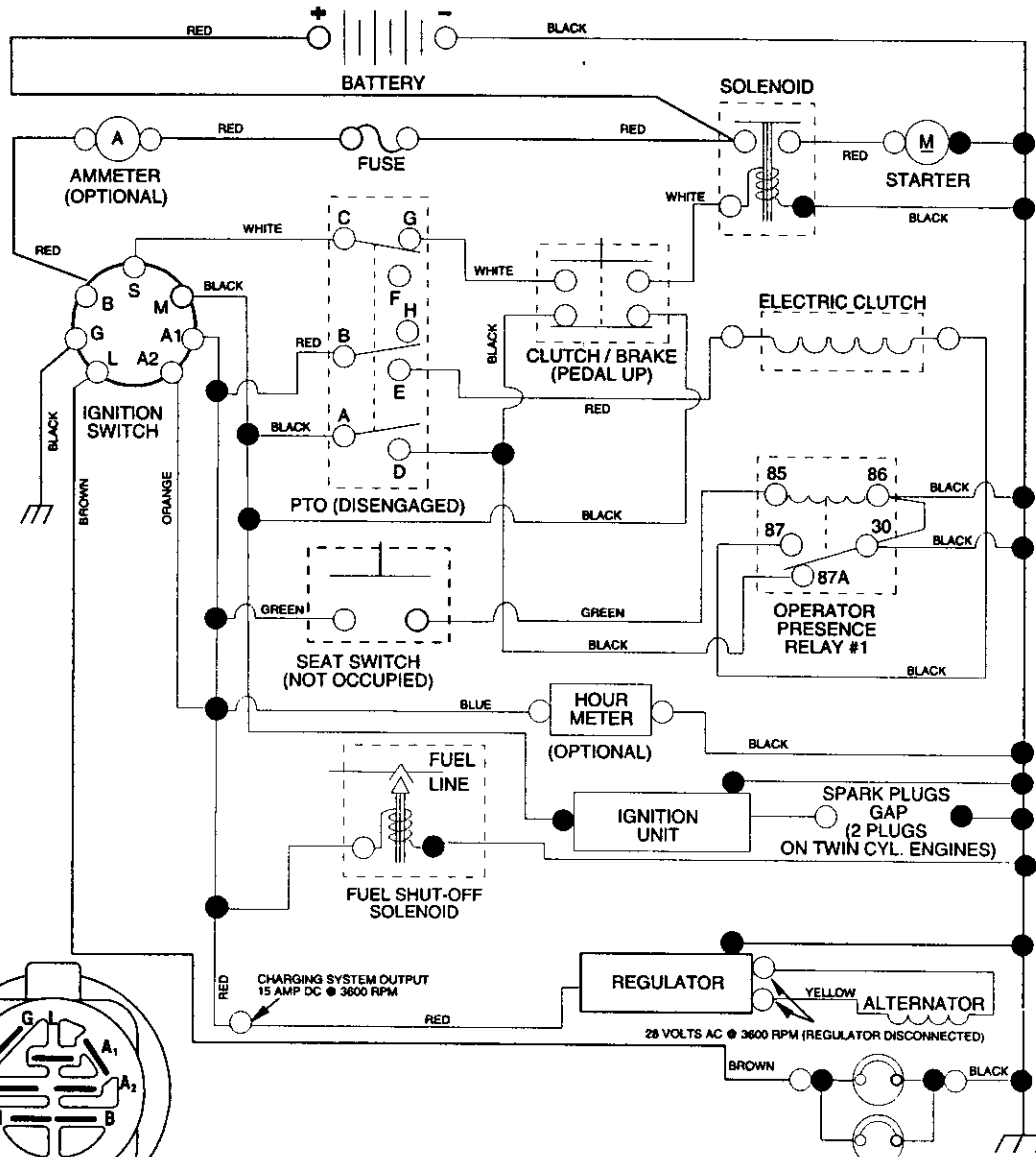

IGNITION SWITCH

POSITION	CIRCUIT	"MAKE"
OFF	M + G + A1	NONE
ON + LIGHTS	B + A1	L + A2
ON	B + A1	NONE
START	B + S + A1	NONE

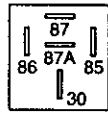

RELAY

PTO SWITCH	
POSITION	CIRCUIT
OFF	C + G, B + H
ON	C + F, B + E, A + D



REMOVABLE CONNECTIONS



NON-REMOVABLE CONNECTIONS

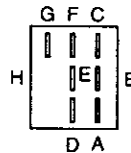

WIRING INSULATED CLIPS
NOTE: IF WIRING INSULATED CLIPS WERE REMOVED FOR SERVICING OF UNIT, THEY SHOULD BE REPLACED TO PROPERLY SECURE YOUR WIRING.

REPAIR PARTS

TRACTOR -- MODEL NUMBER 917.275012

ELECTRICAL

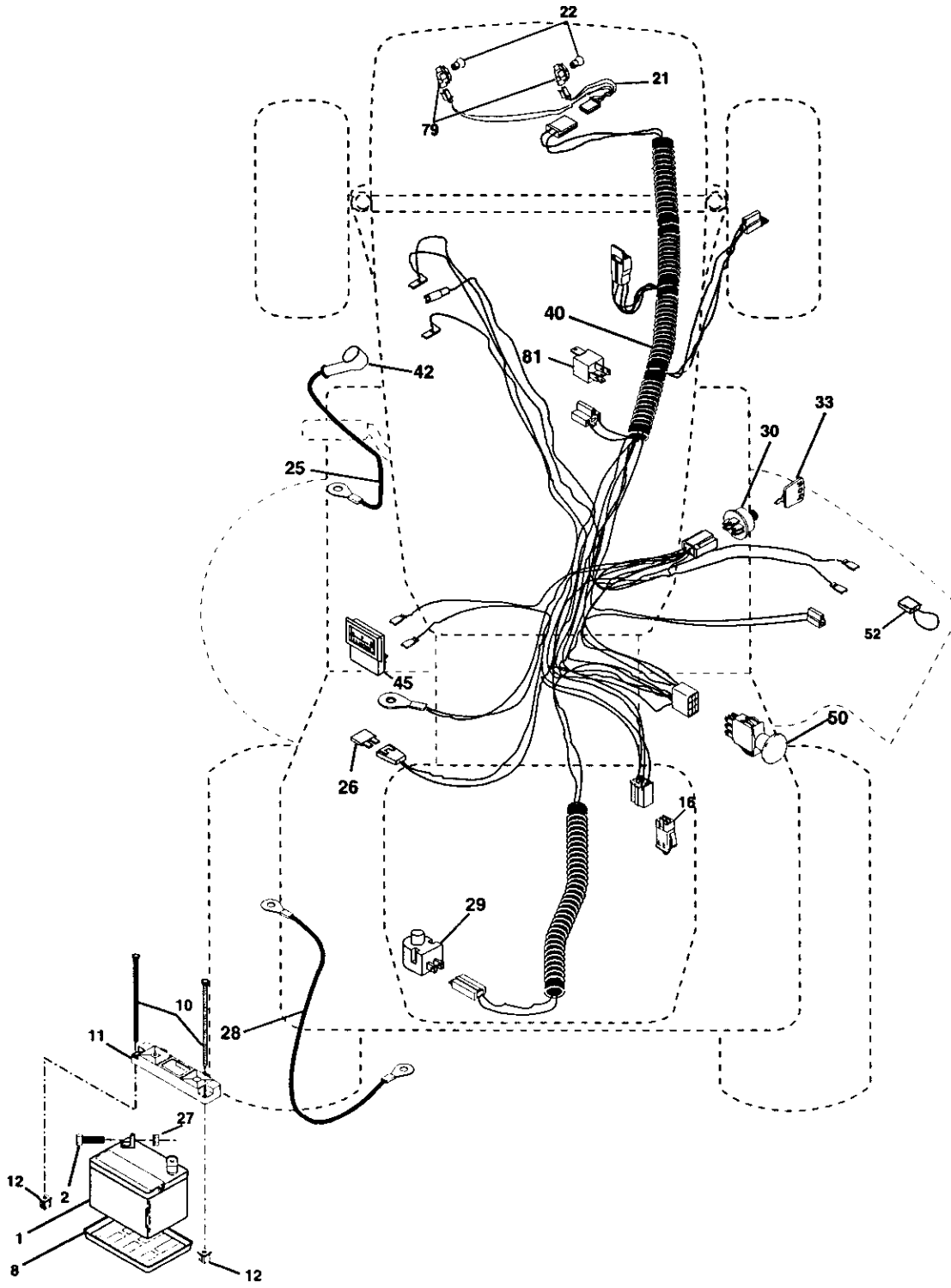

ELECTRICAL

TRACTOR -- MODEL NUMBER 917.275012

KEY PART NO.	PART NO.	DESCRIPTION
1	144927	Battery
2	74760412	Bolt Hex Head 1/4-20 x 3/4
8	7603J	Tray, Battery
10	145211	Bolt 1/4-20 x 7.5 Zinc
11	150109	Hold down Battery Dash Mount
12	145769	Nut Push Nylon 1/4"
16	176138	Switch Interlock Push-In
21	175688	Harness Socket Light W/4152J
22	4152J	Bulb Light
25	150755	Cable, Battery
26	108824X	Fuse
27	73510400	Nut Keps Hex 1/4-20 Unc
28	170697	Cable, Ground
29	160784	Switch, Plunger
30	175566	Switch, Ign
33	140403	Key, Ignition
40	170238	Harness Ign.
42	154336	Cover, Terminal
45	122822X	Ammeter
50	174652	Switch, PTO
52	141940	Hourmeter Adaptor
79	175242	Bulbholder Asm Incandescent SV
81	109748X	Relay Asm.

NOTE: All component dimensions given in U. S.
inches 1 inch = 25.4 mm

TRACTOR -- MODEL NUMBER 917.275012

CHASSIS AND ENCLOSURES

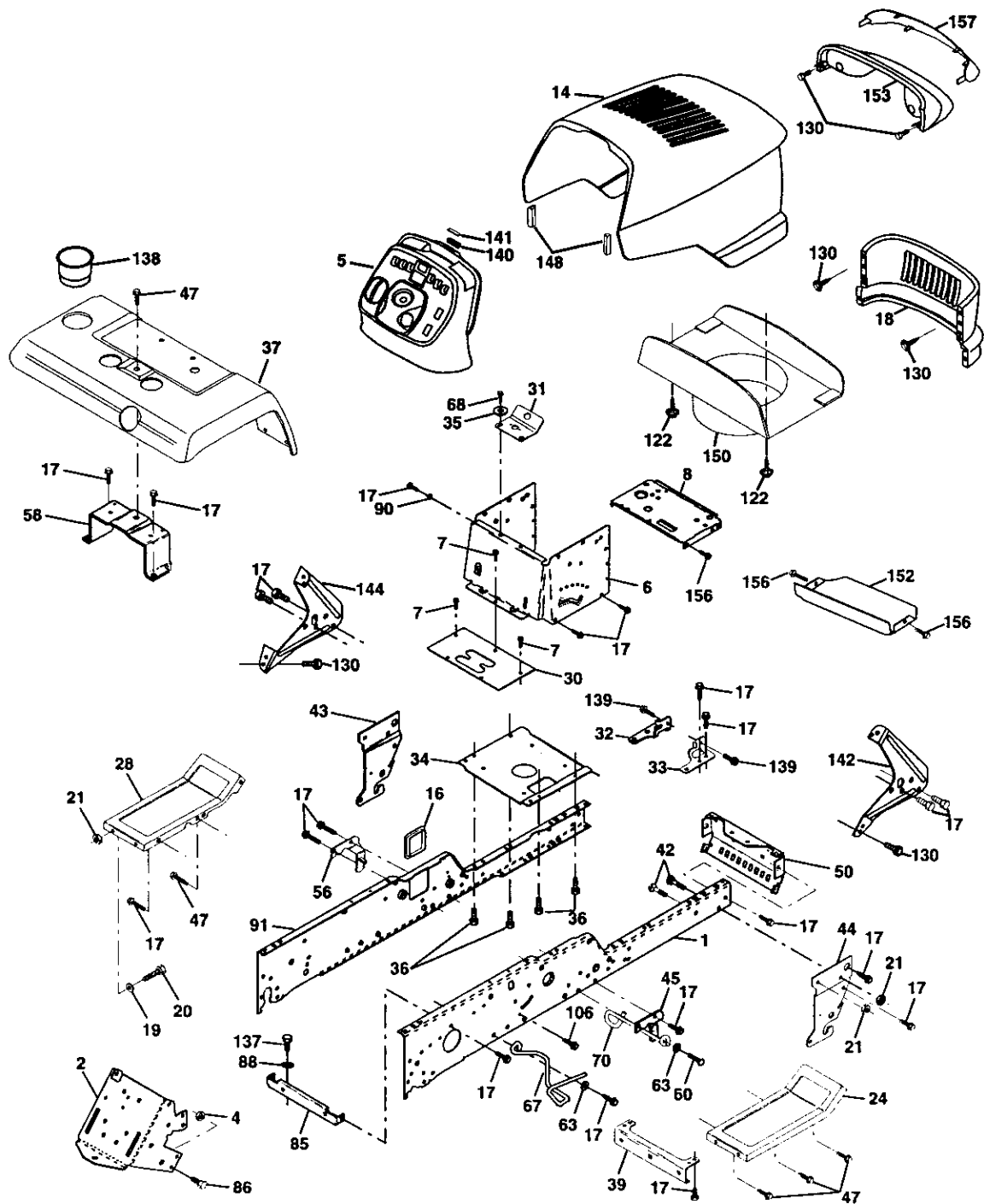

TRACTOR -- MODEL NUMBER 917.275012
CHASSIS AND ENCLOSURES

KEY PART NO.	NO.	DESCRIPTION
1	175465	Rail, Frame RH
2	175282	Drawbar, Gt
4	73680700	Nut, Crownlock Hex 7/16-14UNC
5	163976X428	Dash YTGT 2 Cyl
6	157882	Dash, Lower Vgt One Piece
7	17720408	Screw, Thd Cut 1/4-20 x 1/2
8	145166	Support, Battery
14	175259X558	Hood Asm
16	121794X	Cover, Access
17	17000612	Screw
18	174515X558	Grille
19	19131312	Washer 13/32x13/16x12 Ga.
20	74760616	Bolt Fin Hex 3/8-16 Unc x 1
21	STD541437	Nut Crownlock 3/8-16 Unc
24	179717X558	Footrest, RH
28	179716X558	Footrest, LH
30	145051X014	Saddle, Slksr Vgt
31	161419	Bracket Supt. Steering
32	161327	Bracket, Pivot Chassis Lh
33	161326	Bracket, Pivot Chassis Rh
34	177018	Plate Asm Engine Chassis
35	19111116	Washer 11/32x11/16x16 Ga.
36	17060512	Screw 5/16-18 x 3/4
37	167286X558	Fender
39	175278	Bracket, Axle Front
42	72140608	Bolt, Carriage 3/8-16 x 1
43	136939	Bracket, Spnsn Front Lh
44	136940	Bracket, Spnsn Front Rh
45	176018	Bracket Chassis
47	17670608	Screw Thdrol. 3/8-16 x 1/2
50	175476	Bracket, Chassis Front
56	176016	Bracket Asm., Susp Chassis Lh

KEY PART NO.	NO.	DESCRIPTION
58	175315	Bracket Asm., Fender
60	17490620	Screw Thdrol. 3/8-16 x 1-1/4
63	19131614	Washer 13/32 x 1 x 14 Ga.
67	156973	Guide, Belt Gear Drive
68	17490508	Screw Thdrol. 5/16-18 x 1/2
70	177679	Belt Keeper VGT Ground Drive
85	144911	Bracket, Support Transaxle
86	74760716	Bolt Fin Hex 7/16-14 UNC x 1
88	STD551143	Washer, Lock Hvy Hlcl Spr 7/16
90	STD551237	Washer, Lock External Tooth 3/8
91	175464	Rail, Frame Lh
106	17580520	Screw, Thdrol 5/16-18 x 1.25
122	161464	Screw Hex Wshd 8-18 x 7/8
130	164863	Screw HWHD Hi-Lo #13-16 x 3/4
137	74780716	Bolt Fin Hex 7/16-14 x1 Gr. 5
138	163975X428	Cupholder YTGT
139	171873	Bolt Shoulder 5/16-18 TT
140	163806	Magnet YTGT
141	163805	Striker Plate YTGT
142	161897	Bracket Dash Rh
144	161900	Bracket Dash Lh
148	164655	Extrusion Bumper
150	161237	Duct Heat Hood
152	177956	Shield Browning
153	179761	Light Box Asm w/Lens
156	17060512	Screw 5/16-18 x 3/4
157	161840	Lens Bar

NOTE: All component dimensions given in U.S. inches
1 inch = 25.4 mm

TRACTOR -- MODEL NUMBER 917.275012

GROUND DRIVE

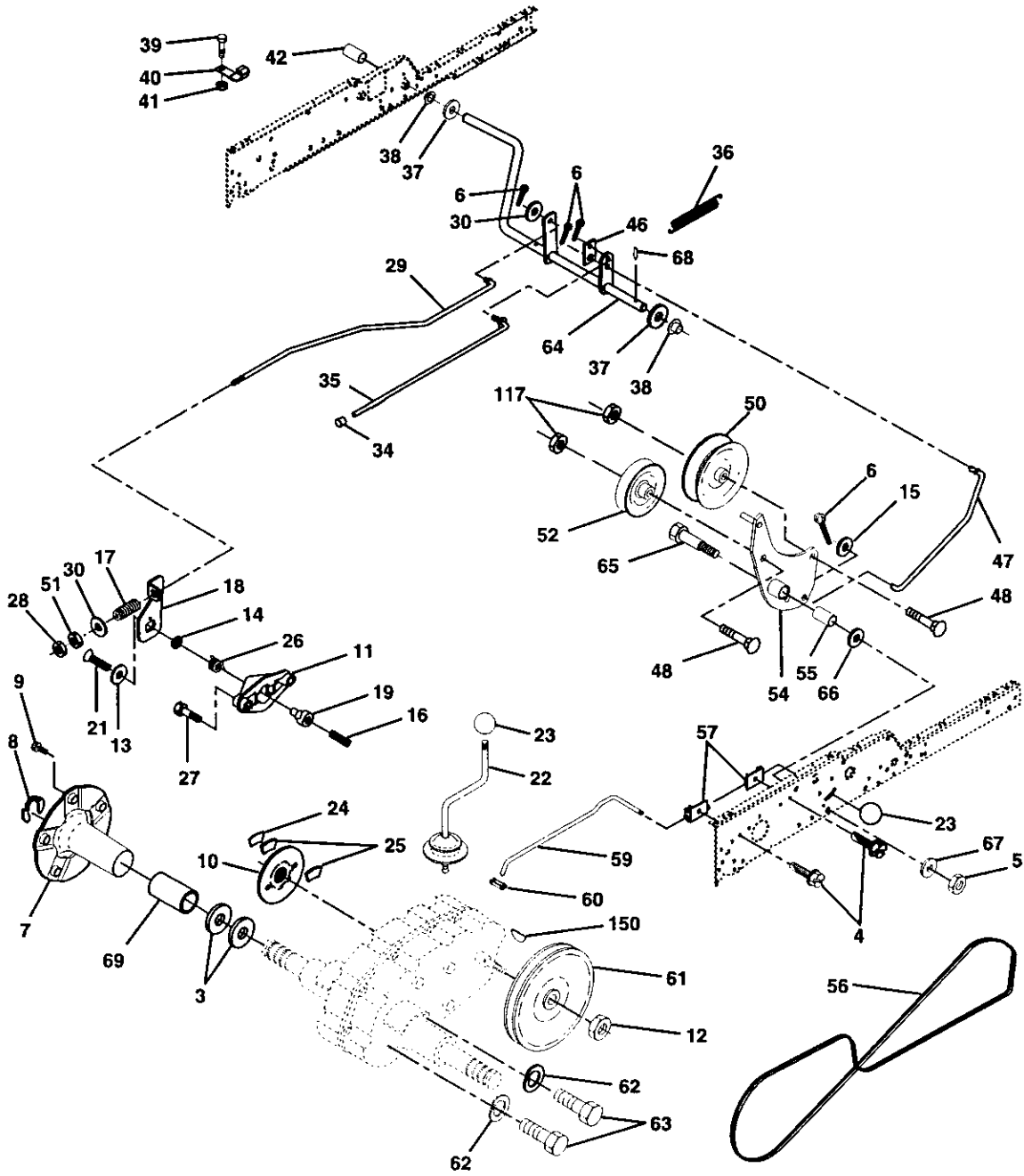

TRACTOR -- MODEL NUMBER 917.275012

GROUND DRIVE

KEY PART NO. NO.	DESCRIPTION	KEY PART NO. NO.	DESCRIPTION
3	7563R Washer, Thrust, Axle	38	150035 Nyliner
4	17490508 Screw Thdrol 5/16-18 x 3/4	39	74321016 Screw, Fin. #10-24 x 1
5	STD541437 Nut, Crownlock 3/8-16	40	178575 Actuator, Interlock Switch
6	STD561210 Pin, Cotter	41	73931000 Nut, Centerlock #10-24
7	149176 Wheel, Hub Assembly	42	8883R Cover, Pedal
8	12000034 Klip, Ring	46	145170 Retainer, Spring
9	140080 Bolt, Hub	47	138228 Clutch Rod
10	142509 Disc, Brake	48	72110612 Bolt, Carr. 3/8-16 x 1-1/2 Gr. 5
11	136927 Yoke, Brake Disc	50	131494 Pulley, Idler, Flat
12	73750800 Nutlock 1/2-20 Unf	51	STD541437 Nut, Crownlock 3/8-16 UNC
13	139419 Washer, Special	52	139123 Pulley, Idler, Grooved
14	138901 Bushing	54	161590 Clutch, Arm Assembly
15	STD551037 Washer 13/32x13/16 x 16 Ga.	55	105706X Bearing, Idler
16	143012 Set, Screw 1/4-28 x 3/4	56	137153 V-Belt
17	126909X Spring	57	141756 Bracket, Shift Rod, Hi-Lo
18	137104 Lever, Brake	59	122253X Shift Rod, Hi-Lo
19	136926 Cam, Brake Disc	60	122268X Spring Clip, Connecting Link
21	23260412 Screw, Flat Head 1/4-28 x 3/4	61	137524 Pulley, Transaxle
22	633A109 Gearshift, Lever Assembly	62	STD551143 Washer, Lock 7/16
23	106932X Knob	63	74760720 Bolt, Fin Hex 7/16-14 x 1-1/4
24	136925 Support, Puck Brake	64	154752 Shaft, Clutch/Brake Pedal
25	136923 Puck, Brake Top	65	179613 Bolt, Shoulder
26	137552 Spring, Return	66	140296 Washer, Hardened
27	17490528 Screw, Hex Wsh Thd. 5/16-18 x 1-3/4	67	19131312 Washer, Flat
28	73350600 Nut, Hex Jam 3/8-16	68	5142H Pin, Roll
29	137213 Brake, Rod	69	136327 Hub, Cover
30	19131616 Washer 13/32 x 1 x 16 Ga.	117	73900600 Nut, Lock Flg. 3/8-16 Unc
34	71673 Cap, Plunger	150	9858M1 Key, Woodruff
35	137648 Rod, Parking Brake		
36	149412 Spring, Drive Ground		
37	121749X Washer 25/32 x1-1/4 x 16 Ga.		

NOTE: All component dimensions given in U.S. inches
1 inch = 25.4 mm

TRACTOR -- MODEL NUMBER 917.275012
STEERING ASSEMBLY

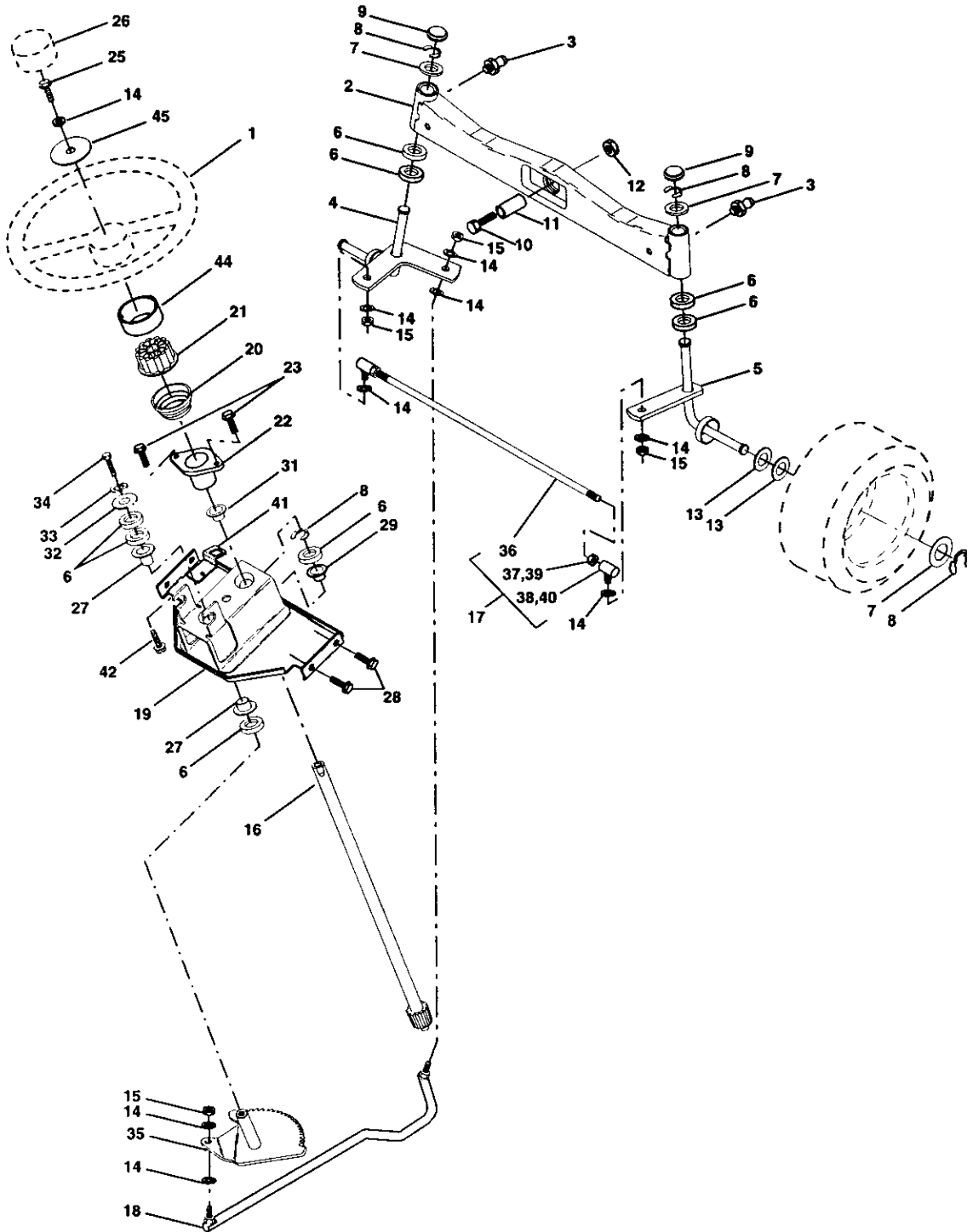

TRACTOR -- MODEL NUMBER 917.275012
STEERING ASSEMBLY

KEY PART NO.	PART NO.	DESCRIPTION
1	159944X428	Wheel, Steering
2	178557	Axle Asm., Front
3	6855M	Fitting, Grease
4	161849	Spindle Asm, LH
5	161848	Spindle Asm., RH
6	6266H	Bearing, Race Thrust Harden
7	121748X	Washer 25/32 x 1-5/8 x 16 Ga.
8	12000029	Ring, Klip #T5304-75
9	121232X	Cap, Spindle
10	74781044	Bolt, Fin Hex 5/8-11 x 2-3/4
11	136518	Spacer Bearing Axle Front
12	73901000	Nut, Lock Flange 5/8-11 Unc
13	121749X	Washer 25/32 x 1-1/4 x 16 Ga.
14	STD551137	Washer, Lock Hvy Hlcl Spr 3/8
15	STD541537	Nut, Lock Center 3/8-24 UNF
16	145103	Shaft Asm., Steering
17	137347	Rod Asm., Tie Ball J Ball Vgt (Inc. Key No. 36-40)
18	175572	Draglink, Ball Joint Solid Vgt
19	156011	Support Asm., Steering Vgt
20	163887X428	Boot, Steering
21	159945	Adapter, Wheel Steering
22	155105	Bushing, Strg. Blk
23	152927	Screw
25	STD523710	Bolt, Fin Hex 3/8-16 x 1 Gr. 5
26	159946X428	Cap, Wheel Steering
27	3366R	Bearing, Col. Strg.
28	17000612	Screw 3/8-16 x 3/4
29	104239X	Bearing, Flange
31	138136	Bushing, Nyliner Snap
32	19111610	Washer 11/32 x 1 x 10 Ga.
33	10040500	Washer, Lock Hvy Hlcl Spr 5/16
34	74780512	Bolt, Hex Hd 5/16-18 x 3/4
35	138059	Gear, Sector Steering
36	137156	Tie Rod
37	73360600	Jam Nut RH Thread
38	109850X	Joint Asm. Ball RH Thread
39	73700600	Jam Nut LH Thread
40	109851X	Joint Asm. Ball LH Thread
41	155246	Bracket Switch Interlock VGT 97
42	17490508	Screw Thdrol 5/16-18 x 1/2 Tyt
44	160135X428	Extension, Steering
45	19132411	Washer 13/32 x 1-1/20 x 11 Ga.

NOTE: All component dimensions given in U.S. inches
1 inch = 25.4 mm

TRACTOR -- MODEL NUMBER 917.275012

ENGINE

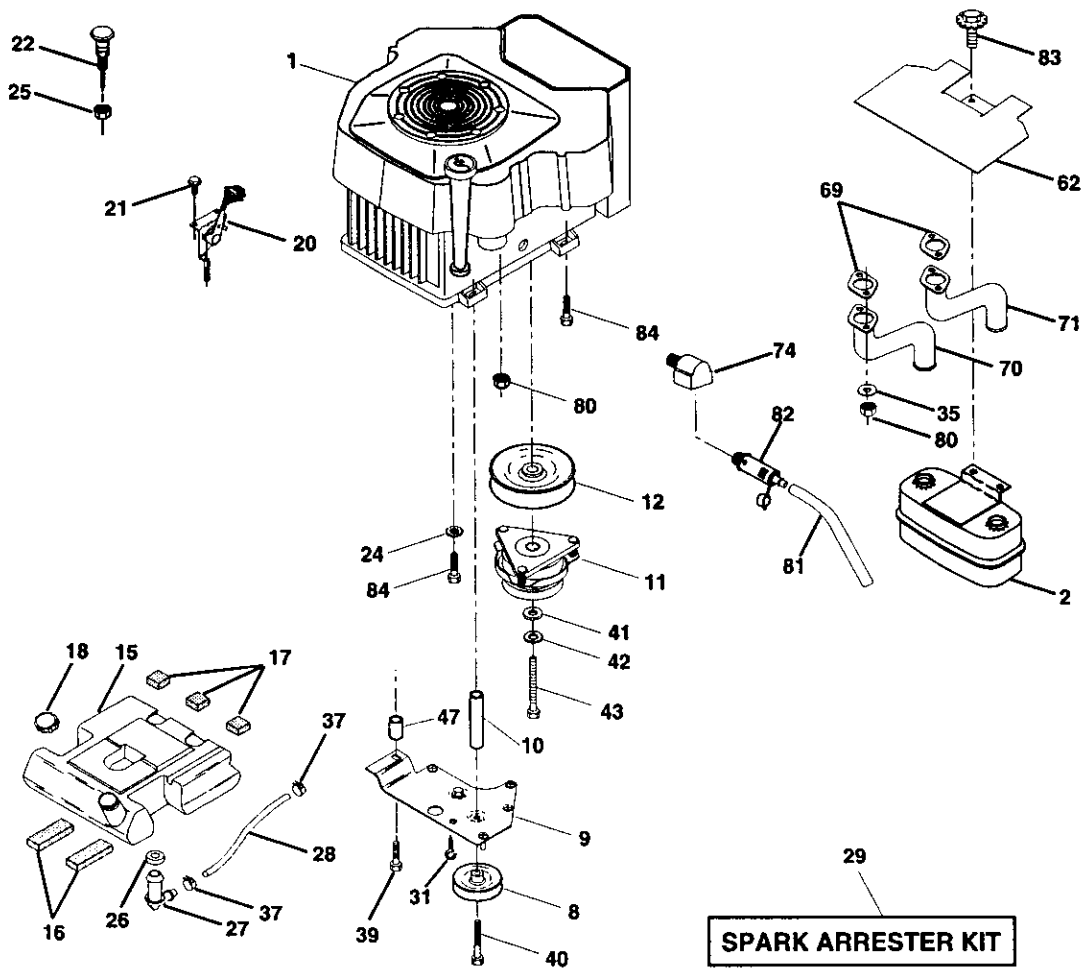

KEY PART NO. NO.

KEY PART NO.	NO.	DESCRIPTION
1	-----	Engine (See Breakdown) Kohler Model No. CV674-75544
2	149723	Muffler
8	121361X	Pulley V-Idler
9	177748	Keeper Asm. Belt Engine
10	175287	Spacer Engine
11	174605	Clutch Electric
12	143996	Pulley Engine VGT Elect Clutch
15	151346	Tank Fuel Rear
16	109227X	Pad Spacer
17	106082X	Pad Spacer
18	161493	Cap Asm Fuel
20	177328X428	Control Throttle
21	164863	Screw hwhd Hi-Lo #13-16x3/4
22	175441X428	Control Choke
24	STD551237	Washer Ext Tooth 3/8
25	73920600	Nut Keps 3/8 - 24 UNF
26	3645J	Bushing
27	139277	Stem Tank Fuel
28	7834R	Fuel Line
29	137180	Spark Arrester Kit

KEY PART NO. NO.

KEY PART NO.	NO.	DESCRIPTION
31	145006	Clip
35	10010500	Washer Split
37	123487X	Clamp Hose
39	17490636	Screw TT 3/8-16 x 2-1/4 UNC
40	17490664	Screw TT 3/8-16 x 4 UNC
41	126197X	Washer 1-1/2 OD x15/32 ID x .250
42	STD551143	Washer Lock 7/16
43	179953	Bolt Hex 7/16 - 20 x 3.75 Gr. 5
47	175288	Bushing
62	146629	Shield Heat Muffler
69	24-041-02	Gasket
70	175545	Tube Exhaust LH
71	175546	Tube Exhaust RH
74	162295	Elbow Street Brass
80	M73030800	Nut Flange
81	148456	Tube Drain Oil Easy
82	148315	Plug Drain Oil Easy
83	171877	Bolt 5/16-18unc x 3/4
84	17060624	Screw Thdrol 3/8-16 x 1-1/2

NOTE: All component dimensions given in U. S. inches 1 inch = 25.4 mm

TRACTOR -- MODEL NUMBER 917.275012

SEAT ASSEMBLY

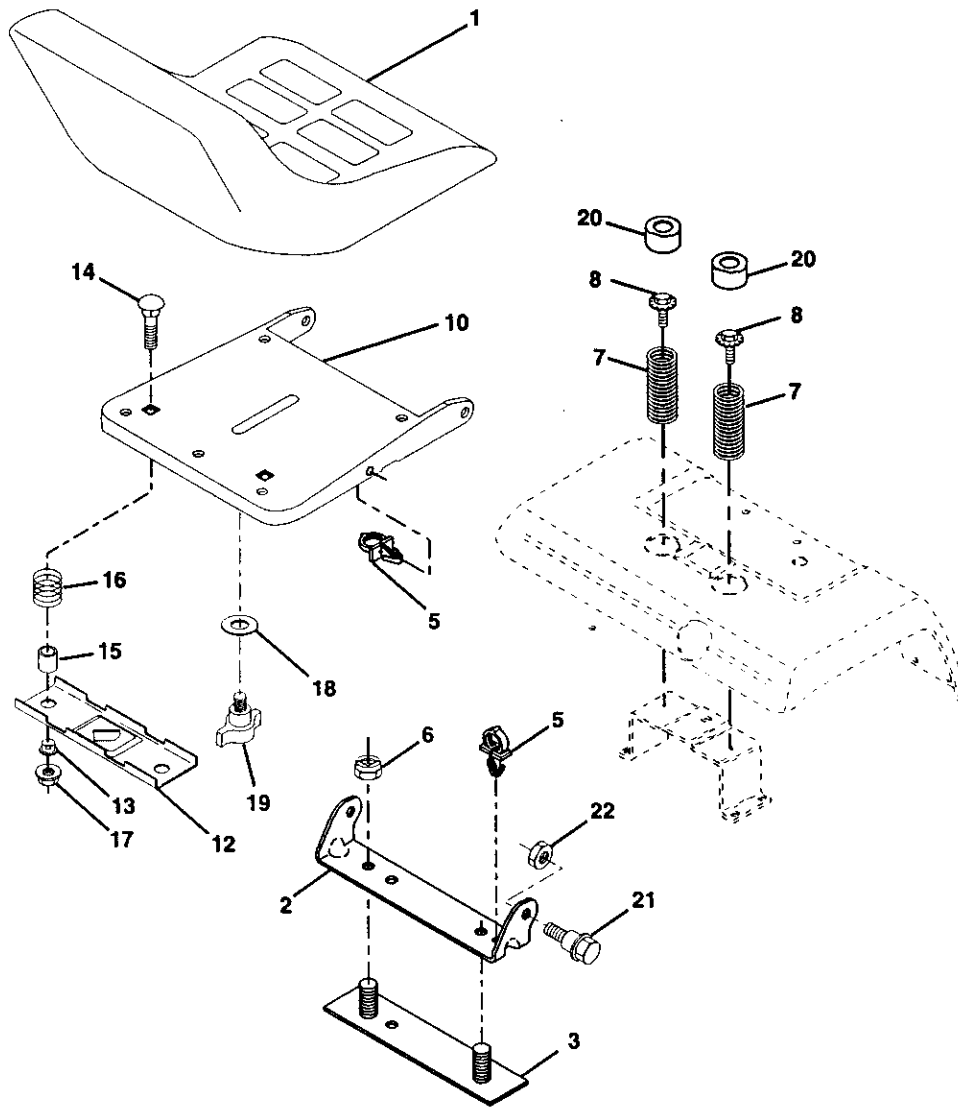

KEY PART NO. NO.

KEY PART NO.	NO.	DESCRIPTION
1	180598	Seat
2	180166	Bracket, Pivot Seat
3	140675	Strap, Fender
5	145006	Clip, Push In, Hinged
6	STD541437	Nut, Crownlock 3/8-16 Unc
7	124181X	Spring, Seat Cprsn
8	171877	Bolt 5/16-18Uncx3/4 w/Sems
10	180186	Pan, Seat
12	121246X	Bracket, Mounting Switch
13	121248X	Bushing, Snap
14	72050412	Bolt, Carriage 1/4-20 X 1-1/2

KEY PART NO. NO.

KEY PART NO.	NO.	DESCRIPTION
15	121249X	Spacer, Split
16	123740X	Spring, Cprsn
17	123976X	Nut, Lock 1/4 Lge Flg Gr. 5
18	19171912	Washer 17/32x1-3/16x12 Ga.
19	166369	Knob, Seat
20	124238X	Cap, Spring Seat
21	171852	Bolt, Shoulder 5/16-18
22	73800500	Nut, Lock Hx w/Ins. 5/16-18

NOTE: All component dimensions given in U. S. inches 1 inch = 25.4 mm

TRACTOR -- MODEL NUMBER 917.275012

DECALS

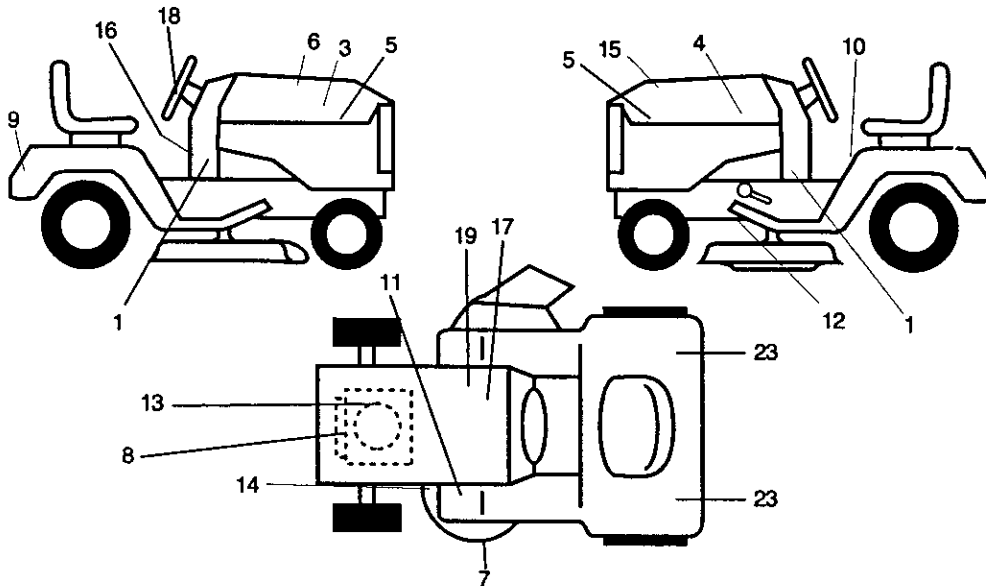

KEY NO.	PART NO.	DESCRIPTION
1	177375	Decal, Dash Panel, Lower
3	171702	Decal, Hood, RH
4	171703	Decal, Hood, LH
5	177415	Decal, Hood Side Panel
6	133644	Decal, Maintenance
7	178482	Decal Mower Heavy Duty
8	177416	Decal, Engine
9	163204	Decal, Fender, Craftsman
10	156439	Decal, Fender Danger
11	181249	Decal, Clutch/Brake
12	146047	Decal, V-Belt Drive Schematic
13	164884	Decal, Blower Housing

KEY NO.	PART NO.	DESCRIPTION
14	175291	Decal, V-Belt Schematic
15	177541	Decal, Repl Parts
16	164085	Decal, Dash Amm Eng.
17	149516	Decal, Battery Dnge/Poi
18	164065	Decal, Insert Strg
19	138047	Decal, Battery
23	106202X	Reflector, Taillight
--	138311	Decal, Handle Lft Height Adjust (Lift Handle)
--	179768X428	Pad, Footrest LH
--	179769X428	Pad, Footrest RH
--	182733	Manual, Owner's (Eng)
--	182734	Manual, Owner's (Span)

WHEELS & TIRES

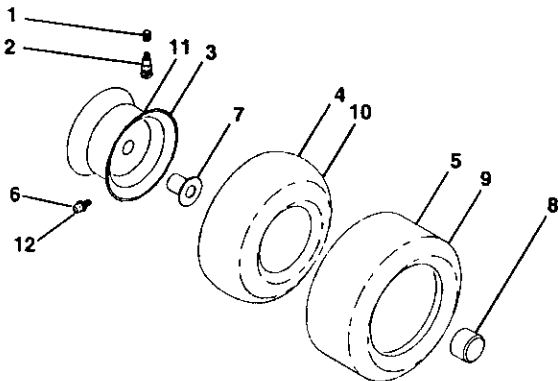

KEY NO.	PART NO.	DESCRIPTION
1	59192	Cap, Valve, Tire
2	65139	Stem, Valve
3	106228X427	Rim Assembly, Front
4	8134H	Tube, Front (Service Item Only)
5	106230X	Tire, Front
6	278H	Fitting, Grease (Front Wheel Only)
7	9040H	Bearing, Flange (Front Wheel Only)
8	104757X428	Cap, Axle (Front Wheel Only)
9	105588X	Tire, Rear
10	7154J	Tube, Rear (Service Item Only)
11	106277X428	Rim Assembly, Rear
12	6856M	Fitting, Grease
--	144334	Sealant, Tire (10 oz. Tube)

NOTE: All component dimensions given in U.S. inches
1 inch = 25.4 mm

TRACTOR -- MODEL NUMBER 917.275012

LIFT ASSEMBLY

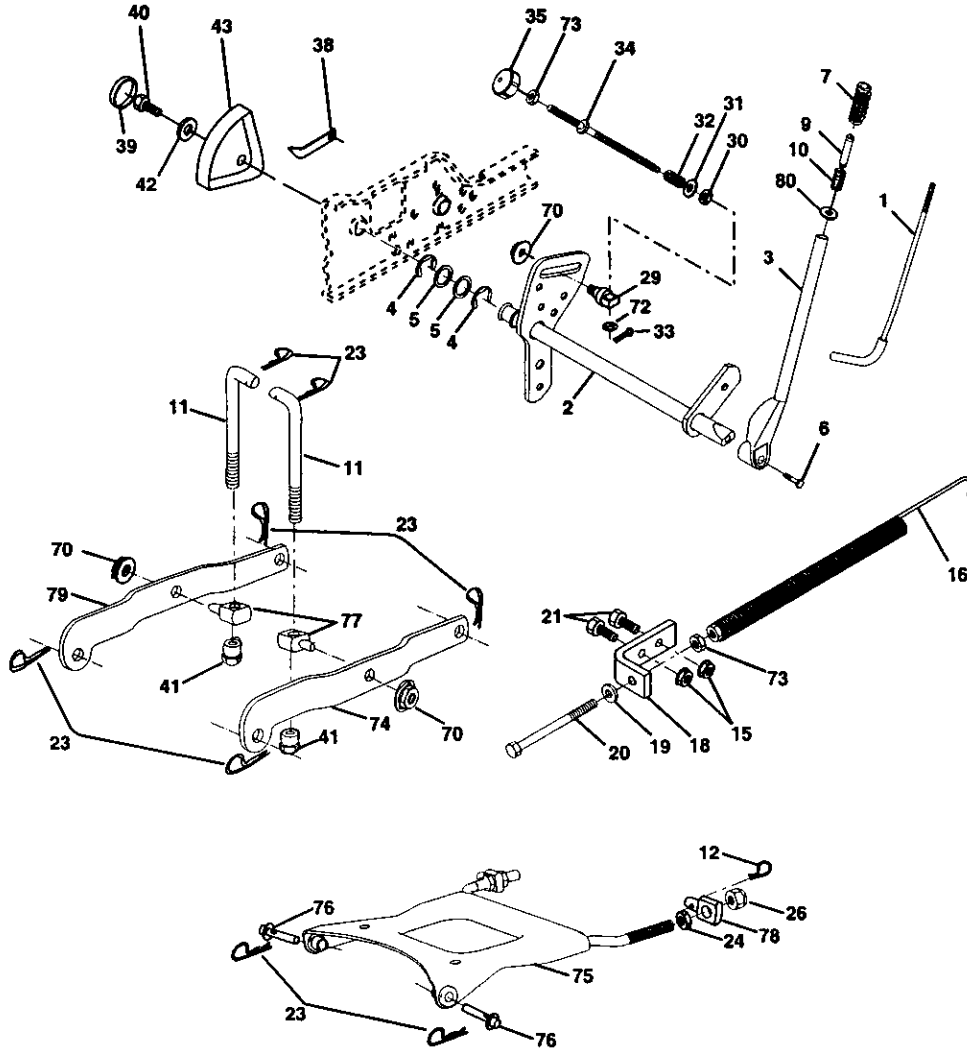

KEY PART NO. NO.

NO.	NO.	DESCRIPTION
1	121006X	Rod Asm., Lever
2	180045	Shaft Asm., Lift Vgt
3	159189	Lever Asm., Lift Rh
4	12000022	E-Ring Truarc #5133-87
5	19292016	Washer 29/32 x 1-1/4 x 16 Ga.
6	71110624	Bolt, Fin Hex 3/8-16 unc x1-1/2
7	175830	Grip, Handle Fluted
9	175831	Plunger, Button
10	2876H	Spring 2-1/8"
11	175375	Link Lift
12	163552	Retainer Spring
15	STD541437	Nut, Crownlock 3/8-16 Unc
16	674A247	Spring Asm., Assist Lift
18	143363	Bracket, Spring Assist
19	STD551037	Washer 13/32 x 13/16 x 16 Ga.
20	5328J	Bolt, Adjust Spring Assist
21	STD52710	Bolt, Fin Hex 3/8-16 x 1
23	STD624008	Retainer, Spring
24	73350800	Nut, Jam Hex 1/2-13 Unc
26	73680800	Nut, Crownlock 1/2-13 Unc
29	150233	Trunnion, Infin Height
30	110807X	Nut, Special
31	19131016	Washer 13/32 x 5/8 x 16 Ga.

KEY PART NO. NO.

NO.	NO.	DESCRIPTION
32	137150	Spring, Compression Inf Hgt
33	STD560907	Pin, Cotter 3/32 x 1/2
34	137167	Rod, Adj Lift
35	138057	Knob, Inf 3/8-16 Unc
38	155097	Pointer, Height Indicator
39	123935X	Plug, Hole
40	17060516	Screw 5/16-18 x 1
41	175994	Nut, Lift Link 7/16-20
42	19112410	Washer 11/32 x 1-1/2 x10 Ga.
43	123934X	Scale, Indicator Height
70	145212	Nut Hex Flange Lock
72	110452X	Nut Push Phos & Oil
73	73350600	Nut Hex Jam 3/8-16 Unc
74	175802	Arm Susp. RR. RH
75	175805	Plate Asm Susp. Front
76	175560	Pin Flange
77	176205	Trunnion Susp. Arm
78	175689	Trunnion Susp. Front
79	175378	Arm Susp. RR. LH
80	126684X	Washer Shim 1/4-5/8 x .062

NOTE: All component dimensions given in U.S. inches
1 inch = 25.4 mm

TRACTOR -- MODEL NUMBER 917.275012

MOWER DECK

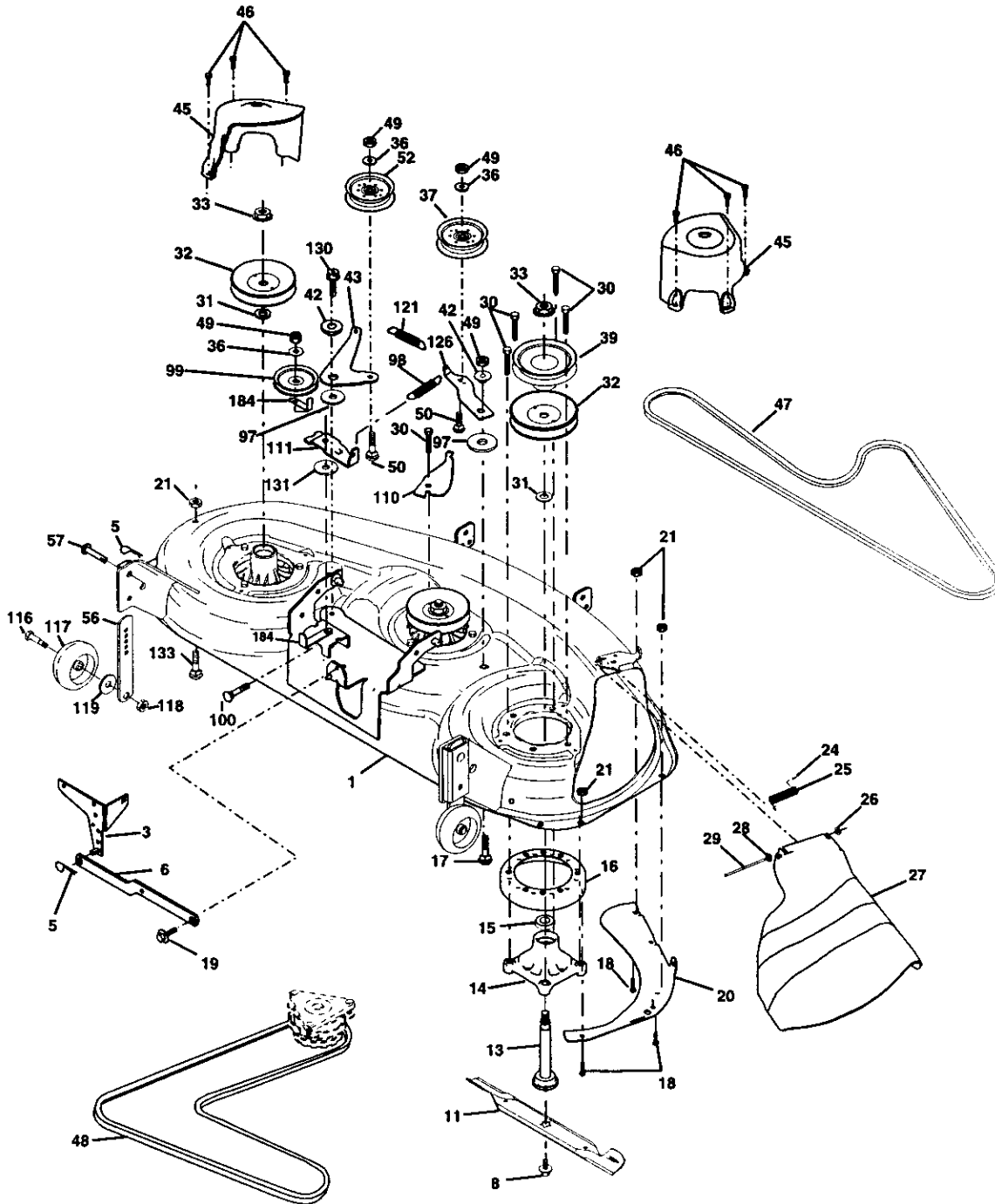

TRACTOR -- MODEL NUMBER 917.275012

MOWER DECK

KEY PART NO. NO.	DESCRIPTION	KEY PART NO. NO.	DESCRIPTION
1 180359	Deck Weldment Mower 48	46 137729	Screw, Thdroll. 1/4-20 x 5/8
3 178915	Bracket Asm., Sway Bar	47 180808	V-Belt, Mower, Secondary
5 4939M	Retainer Spring	48 174368	V-Belt, Mower, Primary
6 178024	Bar Sway Deck	49 73680600	Nut, Crownlock 3/8-16 UNC
8 174365	Bolt 7/16 Asm. Blade	50 72110612	Bolt, Carr. 3/8-16 x 1-1/2 Gr. 5
11 180054	Blade	52 175820	Pulley Idler Flat
13 175147	Shaft Asm. w/Lower Bearing	56 155986	Bar Pnt Adj.
14 174358	Housing Mandrel	57 156941	Pin Head Rivet
15 110485X	Bearing, Ball, Mandrel	97 133943	Washer Hardened
16 174493	Stripper Mandrel Deck	98 179479	Spring Primary Drive
17 72110610	Bolt RDHD Sq Neck 3/8-16 x 1.25	99 175080	Pulley Idler"V"
18 72140505	Bolt, Carriage 5/16-18 x 5/8	100 72110616	Bolt RDHD Sqnk 3/8-16 UNC x 2
19 132827	Bolt, Hex Hd, Shoulder 5/16-18	107 175294	Baffle Vac Edge Mower
20 174378	Baffle, Vortex Mower	108 72110404	Bolt Carr.
21 73680500	Nut, Crownlock 5/16-18 UNC	109 73680400	Nut Crownlock 1/4-20
24 105304X	Cap, Sleeve	110 175016	Arm Spring Secondary
25 178102	Spring, Torsion	111 174610	Arm Spring Fixed Tension
26 110452X	Nut, Push	113 72110506	Bolt Carr. 5/16-18 x 3/4
27 180655X428	Deflector Shield	116 137644	Bolt, Shoulder
28 19111016	Washer 11/32 x 5/8 x 16 Ga.	117 174873	Gauge Wheel
29 131491	Rod, Hinge Head	118 73930600	Nut, Centerlock 3/8-16 UNC
30 173984	Screw, Thdrol	119 19121414	Washer 3/8 x 7/8 x 14 Ga.
31 129963	Washer, Spacer Mower Vented	121 174371	Spring Secondary Drive
32 177865	Pulley, Mandrel	126 174372	Arm, Idler, Primary Deck
33 178342	Nut, Flg. Top Lock Cntr. 9/16	130 17060616	Screw 3/8-16 x 1.0
36 19131316	Washer 13/32 x 13/16 x 16 Ga.	131 19131606	Washer 13/32 x 1/4 x 16 Ga.
37 177968	Pulley, Idler, Primary	184 173979	Keeper Belt Idler Plated
39 174375	Pulley, Idler, Driven	-- 181704	Replacement Mower, Complete
42 165723	Spacer, Retainer	-- 174357	Mandrel Asm. Service (Includes Key Nos. 13-15)
43 174373	Arm, Idler Secondary		
45 174343	Cover, Mandrel Deck		

NOTE: All component dimensions given in U. S. inches 1 inch = 25.4 mm

TRACTOR -- MODEL NUMBER 917.275012

TRANSAXLE

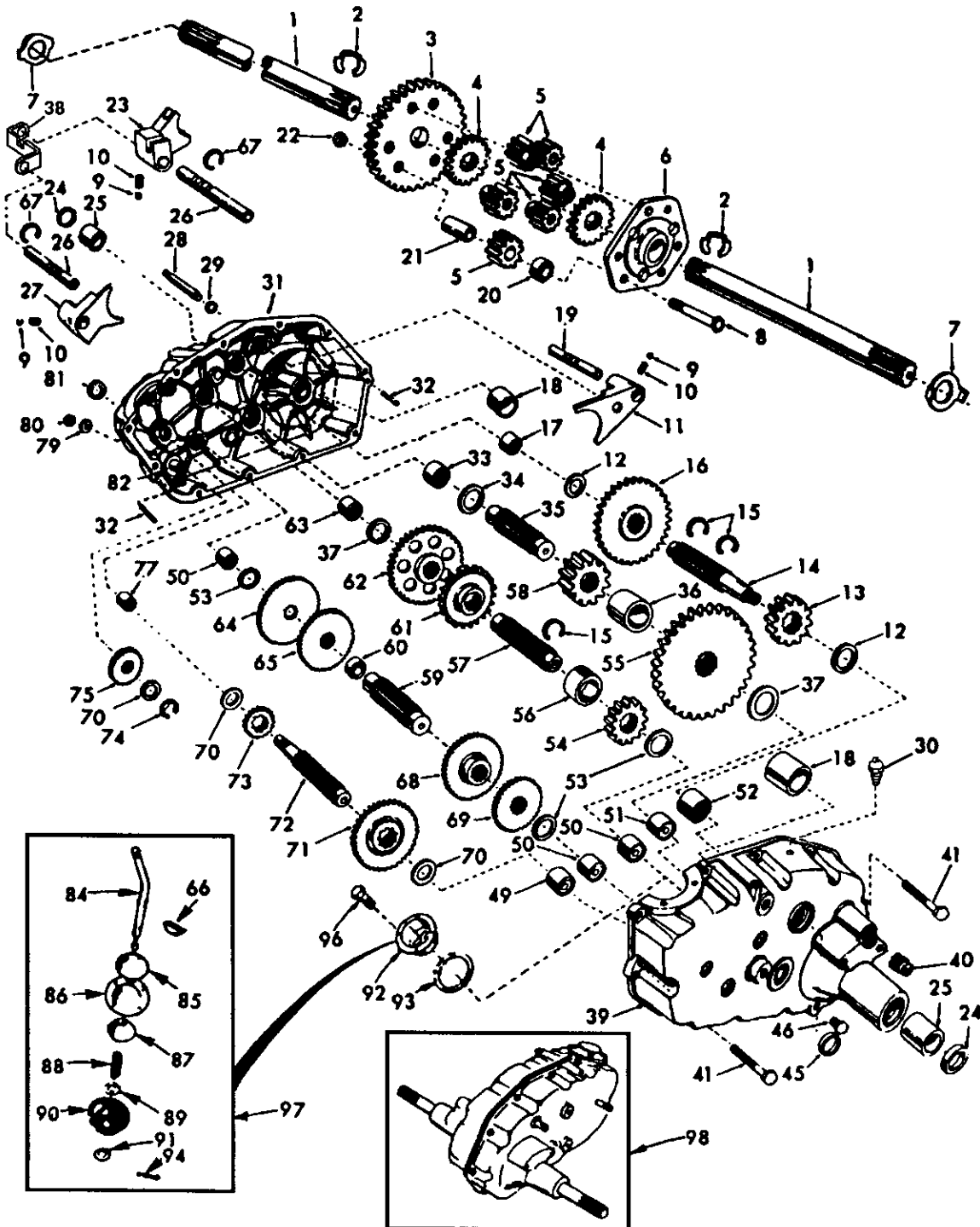

TRACTOR -- MODEL NUMBER 917.275012

TRANSAXLE

KEY PART NO.	KEY PART NO.	DESCRIPTION	KEY PART NO.	KEY PART NO.	DESCRIPTION
1	4197R	Axle Shaft	52	8119M	Needle Bearing
2	12000034	Retaining Ring	53	4220R	Thrust Bearing Race
3	4199R	Final Drive Gear	54	4209R	3rd Reduction Pinion, Low
4	4216R	Differential Gear	55	4213R	4th Reduction Gear
5	4215R	Differential Pinion	56	4442R	3rd Reduction Pinion Spacer
6	4217R	Differential Carrier	57	4195R	2nd Reduction Gear Shaft
7	174728	Axle Thrust Washer	58	4214R	Final Drive Pinion
8	74020652	Bolt, Hex Head 3/8-24 x 3-1/4 (1" Thread Length)	59	4194R	1st Reduction Gear Shaft
9	7392M	Steel Ball	60	7528R	1st Reduction Shaft Spacer
10	137261	Spring Shift Fork Detent	61	4208R	3rd Reduction Pinion High
11	4985R	Shift Fork, High-Low Range	62	4207R	2nd Reduction Gear
12	6266H	Thrust Bearing Race	63	7398H	Needle Bearing
13	4212R	4th Reduction Pinion	64	4203R	Low Speed Gear and 2nd Reduction Pinion Cluster
14	137125	Shaft, Brake	65	4204R	Reverse Gear
15	6276H	Snap Ring, Crescent Type	66	2898J	Key, Hi-Pro 1/8 x 17/32
16	633A63	High-Low Range Gears	67	12000033	Klip Ring
17	8118M	Needle Bearing	68	4205R	Intermediate Speed Gear
18	8740H1	Sintered Iron Bearing	69	4206R	High Speed Gear
19	122238X	Shift Fork Shaft, High-Low Range	70	1370H	Thrust Bearing Race
20	4218R	Differential Pinion Spacer	71	633A69	Intermediate and High Speed Cluster Pinions
21	6252H1	Differential Pinion Bushing	72	139120	Input Shaft
22	7810H	Gripco Centerlock Nut 3/8-24	73	4201R	Low Speed Pinion
23	6262H	Shift Fork, R.H.	74	12000008	E-Ring
24	7393R	Oil Seal	75	1153R	Reverse Idler Gear
25	992R1	Sintered Iron Bearing	77	6803J	Needle Bearing
26	139111	Shift Fork Shaft	79	1167R	Sealing Washer
27	4986R	Shift Fork, L.H.	80	73360700	Nut, Hex, Jam 7/16-20
28	122254X	Shift Shaft, High-Low Range	81	6270H	Oil Seal
29	6269H	Oil Seal	82	136984	Reverse Idler Shaft
30	5855H	Pressure Relief Valve	84	5384J	Gearshift Lever, Bent
31	174731	Gearcase, Reverse Idler Shaft and Bearings, R.H. (Includes Key No.'s 17, 18, 25, 33, 50, 63, 77 and 82)	85	2978J	Gearshift Cap
32	6277H	Dowel Pin	86	633A85	Gearshift Ball Cover and Pin
33	4225R	Needle Bearing	87	8739H1	Shift Lever Guide Ball, Keyed
34	7396H	Thrust Bearing Race	88	4924H	Spring
35	4198R	4th Reduction Gear Shaft	89	19151516	Washer 15/32 x 15/16 x 16 Ga.
36	4200R	4th Reduction Gear Spacer	90	110542X	Shift Mechanism Seal
37	7395H	Thrust Bearing Race	91	19181511	Washer 9/16 x 15/16 x 12 Ga.
38	160789	Gate, Lower, Shift	92	75J	Gearshift Gate and Reinforcement
39	174729	Gearcase and Bearings, L.H. (Includes Key numbers 18, 25, 49, 50 (2), 51 and 52)	93	6274H	Shift Ball Cover Gasket
40	13320400	Pipe Plug 1/2-14 N.P.T.	94	76020412	Cotter Pin 1/8 x 3/4
41	17580520	Bolt, Hex 5/16-18 UNC x 1-1/4	96	159783	Screw, Hex, Washer, HD.
45	6271H	Oil Seal	97	633A109	Gearshift Lever Assembly
46	13060200	Pipe Plug 1/4-18 N.P.T.	98	174742	Transaxle, 6 Speed, Complete Assembly
49	4895H	Needle Bearing			
50	4222R	Needle Bearing			
51	1529R	Needle Bearing			

NOTE: All component dimensions given in U.S. inches
1 inch = 25.4 mm

**TRACTOR -- MODEL NUMBER 917.275012
 KOHLER ENGINE-MODEL NUMBER CV674, TYPE NUMBER 75544**

CYLINDER HEAD, VALVE AND BREATHER

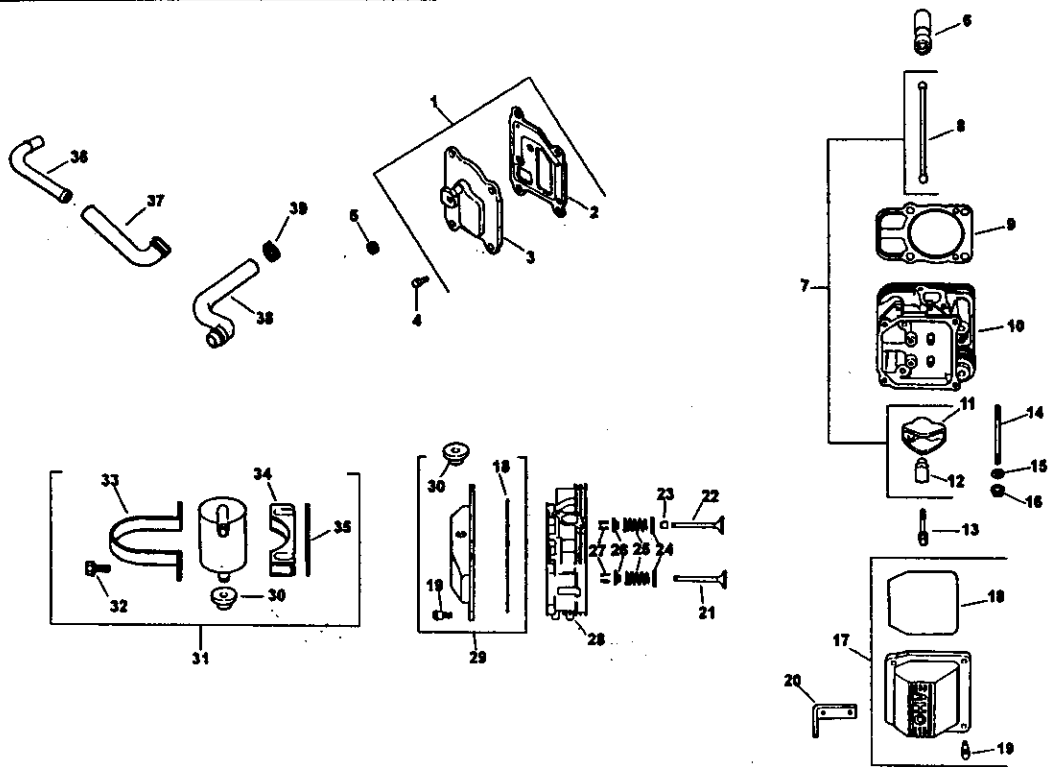

CRANKCASE

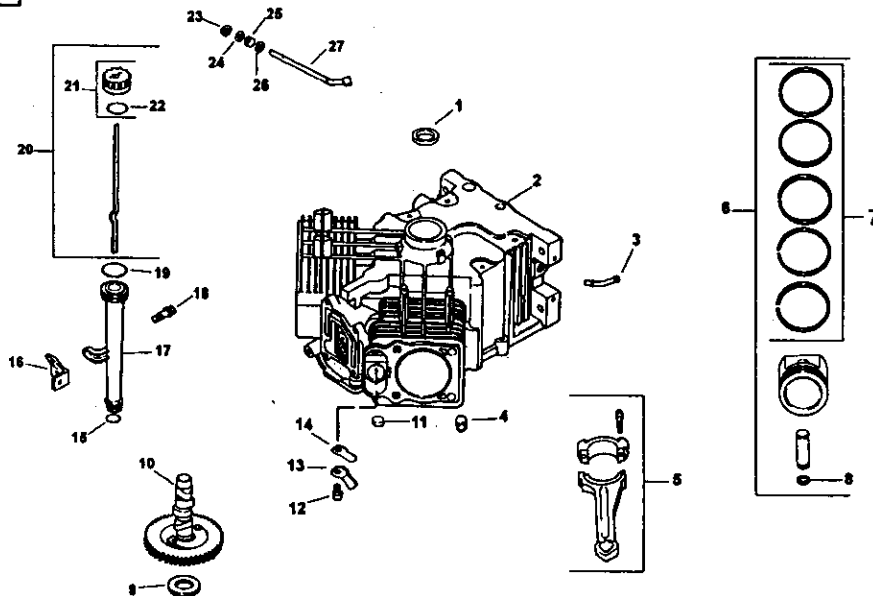

TRACTOR -- MODEL NUMBER 917.275012
KOHLER ENGINE-MODEL NUMBER CV674, TYPE NUMBER 75544

HEAD/VALVE/BREATHER

KEY PART NO. NO.	DESCRIPTION
1.	24-033-03-S Kit, breather cover w/gasket (Includes 2, 3)
2.	24-041-23-S Gasket, breather
3.	24-096-59-S Cover, breather
4.	M-645020-S Screw, hex. flange M6x1.0x20 (4)
5.	X-75-23-S Plug, allen hd. 1/8"
6.	25-351-01-S Lifter, valve (4)
7.	24-755-66-S Kit, valve train (Includes 8, 11, 12)
8.	24-411-05-S Rod, push (4)
9.	24-041-40-S Gasket, cylinder head (2)
10.	24-318-70-S Head assembly, #2 cylinder
11.	25-186-01-S Arm, rocker (4)
12.	24-599-01-S Pivot, rocker arm (4)
13.	M-640034-S Screw, hex. flange M6x1.0x34 (4)
14.	24-072-09-S Stud, cylinder head M8x1.25x20, M10x1.5x33, 105 mm long (8)
15.	24 468 16-S Washer, flat 8 mm (8)
16.	24 100 10-S Nut, hex. flange M8x1.25 (2)
17.	24-755-74-S Kit, valve cover - plain (Includes 18, 19)
18.	24-153-16-S O-Ring
19.	24-086-32-S Screw, shoulder (4)
20.	24-445-01-S Strap, lifting
21.	24-016-01-S Valve, exhaust (Std.) (2)
22.	24-016-02-S Valve, exhaust (.25) (2)
22.	24-017-01-S Valve, intake (Std.) (2)
22.	24-017-02-S Valve, intake (.25) (2)
23.	24-032-05-S Seal, valve stem (2)
24.	235011-S Retainer, spring (4)
25.	24-089-02-S Spring, valve (4)
26.	12-173-01-S Cap, valve spring (4)
27.	12-755-03-S Kit, retainer (4)
28.	24-318-67-S Head assembly, #1 cylinder
29.	24-755-76-S Kit, valve cover - breather (Incl.18, 19, 30)
30.	25-313-02-S Grommet, rubber
31.	24-755-57-S Kit, breather separator (Includes 30, 32-35)
32.	M-545016-S Screw, hex. flange M5x0.8x16 (2)
33.	24-445-02-S Strap, breather
34.	24-126-44-S Bracket, breather separator
35.	24-112-12-S Spacer
36.	24-294-06-S Fitting
37.	24-326-13-S Hose, breather
38.	24-326-14-S Hose, breather
39.	25-237-14-S Clamp, hose (2)

CRANKCASE

KEY PART NO. NO.	DESCRIPTION
1.	24-032-01-S Seal, oil front
2.	Crankcase (USE: Miniblock 24 782 14)
3.	24-294-13-S Fitting
4.	24-380-13-S Pin, dowel locating (6)
5.	24-067-13-S Connecting Rod (Std.) (2)
5.	24-067-14-S Connecting Rod (.25) (2)
6.	24-874-09-S Piston w/Ring Set (Std.) (2) (Includes 7, 8)
	24-874-10-S Piston w/Ring Set (.25) (2)
	24-874-11-S Piston w/Ring Set (.50) (2)
	24-874-15-S Kit, piston w/ring set (.08)
7.	24-108-08-S Ring Set (Std.) (2)
	24-108-09-S Ring Set (.25) (2)
	24-108-10-S Ring Set (.50) (2)
8.	24-018-01-S Retainer, piston pin (4)
9.	12-422-09-S Shim, camshaft (A.R.)
	12-422-13-S Shim, camshaft (A.R.)
	12-422-07-S Shim, camshaft (A.R.)
	12-422-08-S Shim, camshaft (A.R.)
	12-422-10-S Shim, camshaft
	12-422-11-S Shim, camshaft (A.R.)
	12-422-12-S Shim, camshaft (A.R.)
10.	24-012-10-S Camshaft
11.	52-139-09-S Plug, cup
12.	M-545010-S Screw, hex. flange M5x0.8x10 (2)
13.	24-018-04-S Retainer, reed (2)
14.	24-402-05-S Reed, breather (2)
15.	12-153-01-S O-Ring, lower oil fill tube
16.	24-126-19-S Bracket, oil fill tube
17.	12-123-04-S Tube, oil fill
18.	M-545016-S Screw, hex. flange M5x0.8x16
19.	12-153-02-S O-Ring, upper oil fill tube
20.	24-038-04-S Dipstick assembly (Includes 21, 22)
21.	24-755-46-S Kit, oil fill cap (Includes 22)
22.	12-153-03-S O-Ring, dipstick
23.	24-018-09-S Ring, retainer
24.	M-931010-S Washer, nylon (top)
25.	28-032-09-S Seal, governor cross shaft
26.	24-468-15-S Washer (bottom)
27.	24-144-33-S Shaft, governor cross

NOTE: All component dimensions given in U.S. inches 1 inch = 25.4 mm

TRACTOR -- MODEL NUMBER 917.275012
KOHLER ENGINE-MODEL NUMBER CV674, TYPE NUMBER 75544

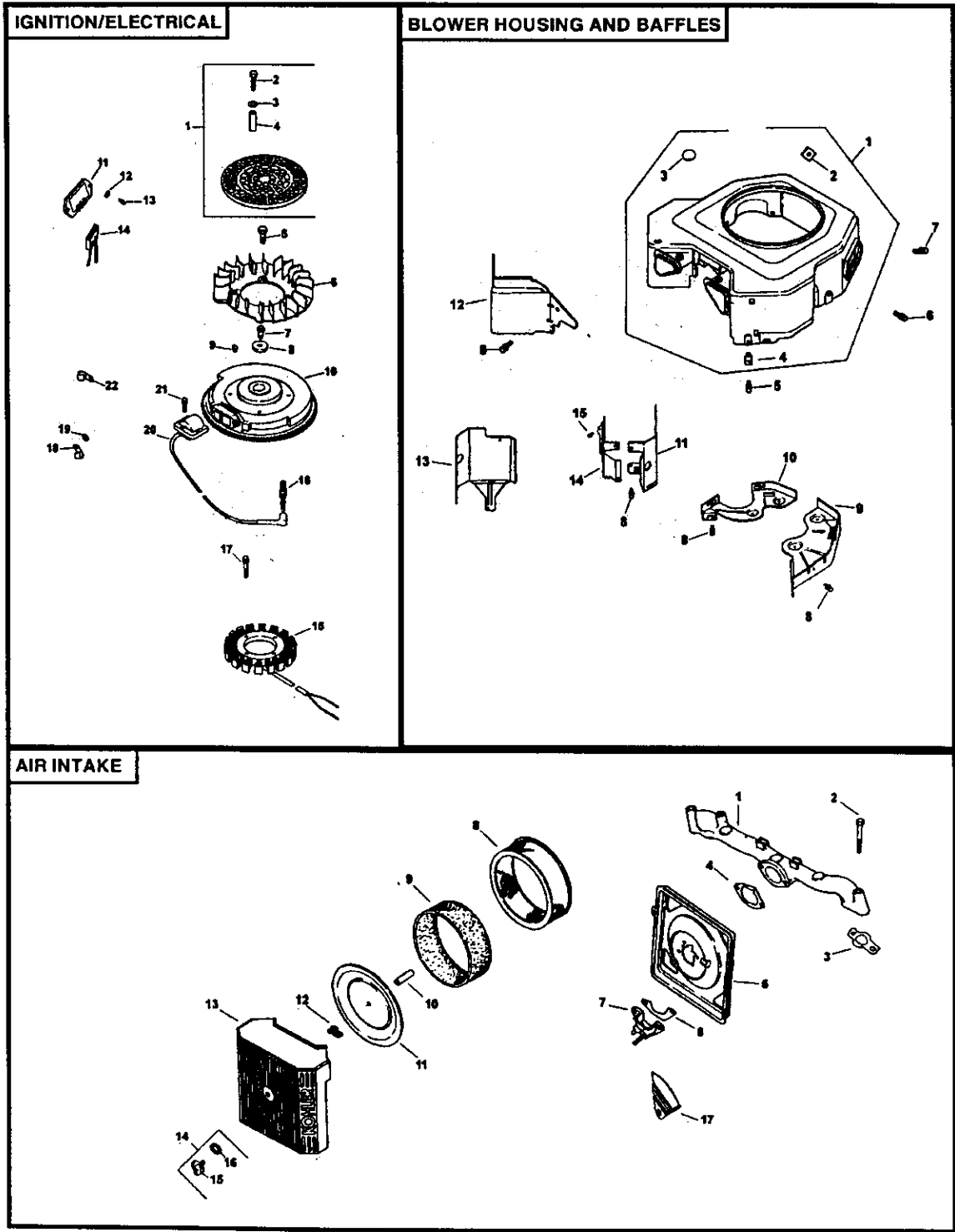

**TRACTOR -- MODEL NUMBER 917.275012
KOHLER ENGINE-MODEL NUMBER CV674, TYPE NUMBER 75544**

IGNITION/CHARGING

KEY NO.	PART NO.	DESCRIPTION
1.	54-755-15-S	Kit, grass screen (Includes 2-4, and 24 113 18-S)
2.	M-403025-S	Screw, hex. cap M4x0.7x25 (4)
3.	X-25-92-S	Washer, plain 5/16" (4)
4.	24-112-04-S	Spacer, grass screen (4)
5.	25-086-47-S	Bolt, shoulder (4)
6.	24-157-03-S	Fan
7.	12-086-14-S	Screw, hex. flange M10x1.5x46
8.	12-468-03-S	Washer, plain 3/8"
9.	X-42-15-S	Key
10.	24-025-04-S	Flywheel
11.	25-403-03-S	Rectifier-regulator
12.	X-25-92-S	Washer, plain 3/16" (2)
13.	24-086-18-S	Screw, phillips hd. 11-16x7/8 (2)
14.	236602-S	Connector (3 contact)
15.	54-755-09-S	Kit, 15 amp stator (Includes 24 126 71-S)
16.	12-132-06-S	Spark Plug (2)
17.	M-548025-S	Screw, hex, cap M5x0.8x25 (2)
18.	48-154-02-S	Clip, cable
19.	X-25-63-S	Washer, plain 1/4"
20.	24-584-01-S	Module, ignition (2)
21.	M-545020-S	Screw, hex flange M5x0.8x20 (4)
22.	235173-S	Clip, cable

NOT ILLUSTRATED

24-126-71-S	Bracket, stator wire
X-22-11-S	Washer, lock 1/4"
24-176-82-S	Harness, wiring Lead, black (rect.-reg. 6" - 12 gauge insulated grip barrel eyelets)
24-113-18-S	Decal, grass screen
25-454-03-S	Tie, wire (3)

BLOWER HOUSING & BAFFLES

KEY NO.	PART NO.	DESCRIPTION
1.	24-027-20-S	Housing, blower (Includes 2-4)
2.	24-100-01-S	Nut, plastic (3)
3.	25-139-16-S	Plug, button 9/16"
4.	24-100-02-S	Nut, plastic (2)
5.	M-545020-S	Screw, hex. flange M5x0.8x20 (4)
6.	M-545016-S	Screw, hex. flange M5x0.8x16 (3)
7.	M-551016-S	Screw, hex. flange M5x0.8x16
8.	M-645016-S	Screw, hex. flange M6x1.0x16 (6)
9.	24-146-16-S	Plate, backing - # 2 side
10.	24-146-20-S	Plate, backing - # 1 side
11.	24-063-20-S	Baffle, cylinder barrel-# 2 side
12.	24-063-14-S	Baffle, valley - #2 side
13.	24-063-58-S	Baffle, cylinder barrel-# 1 side
14.	24-063-23-S	Baffle, valley - #1 side
15.	M-545010-S	Screw, hex. flange M5x0.8x10 (2)

NOT ILLUSTRATED

24-096-66-S	Cover, control
24-086-06-S	Screw, phillips hd. 11-16x3/4" (2)

AIR INTAKE/FILTRATION

KEY NO.	PART NO.	DESCRIPTION
1.	24-164-06-S	Manifold, intake
2.	M-651055-S	Screw, hex. flange M6x1.0x55 (4)
3.	24-041-01-S	Gasket, intake manifold (2)
4.	24-041-14-S	Gasket, air cleaner base
5.	24-094-18-S	Base, air cleaner
6.	24-041-13-S	Gasket, fuel spitback cup
7.	24-109-09-S	Cup, fuel spitback
8.	24-083-03-S	Element, air cleaner
9.	24-083-05-S	Precleaner, element
10.	231032-S	Seal, breather
11.	24-096-01-S	Cover, inner air cleaner
12.	12-100-01-S	Wing Nut
13.	24-096-73-S	Cover, air cleaner
14.	54-755-01-S	Kit, knob with seal (Includes 15 & 16)
15.	25-341-03-S	Knob, cover
16.	24-153-20-S	O-Ring
17.	24-063-51-S	Baffle, spitback cup

NOTE: All component dimensions given in U.S. inches 1 inch = 25.4 mm

TRACTOR -- MODEL NUMBER 917.275012
KOHLER ENGINE-MODEL NUMBER CV674, TYPE NUMBER 75544

STARTING SYSTEM

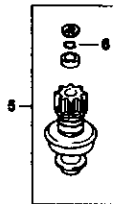
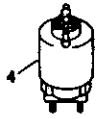
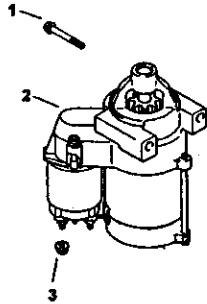

ENGINE CONTROLS

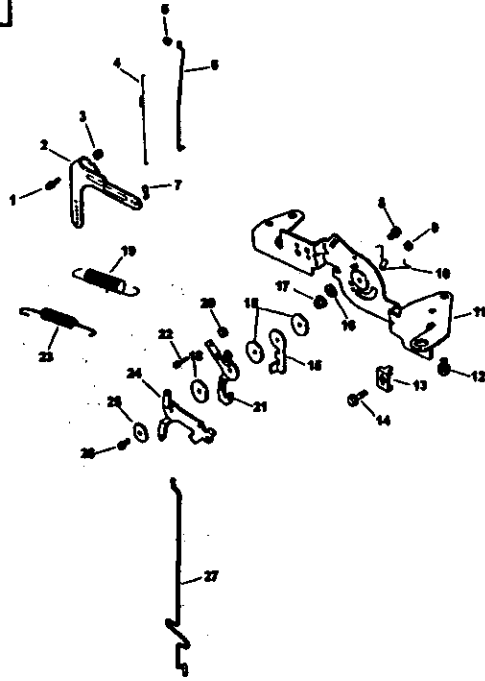

OIL PAN / LUBRICATION

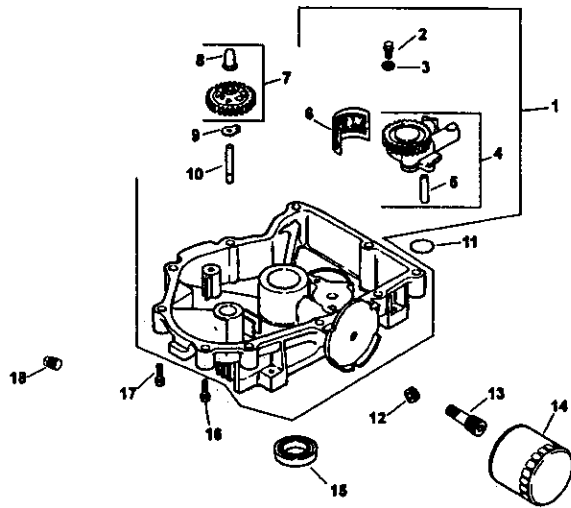

**TRACTOR -- MODEL NUMBER 917.275012
 KOHLER ENGINE-MODEL NUMBER CV674, TYPE NUMBER 75544**

STARTING SYSTEM

KEY PART NO. NO.	DESCRIPTION
1. M-839080-S	Screw, hex. flange M8x1.25x80 (2)
2. 25-098-08-S	Starter, solenoid shift (Includes 4-7)
3. M-841080-S	Nut, hex. flange M8x1.25
4. 25-435-04-S	Kit, solenoid
5. 25-755-33-S	Kit, pinion drive (Includes 6)
6. 25-141-05-S	Ring
7. 25-221-01-S	Kit, brush

ENGINE CONTROLS

KEY PART NO. NO.	DESCRIPTION
1. 24 211 03-S	Bolt, round head square neck
2. 24-090-33-S	Lever, governor
3. M-641060-S	Nut, hex. flange M6x1.0
4. 24-089-01-S	Spring, linkage
5. 25-158-08-S	Bushing, linkage retaining
6. 24-079-04-S	Linkage, throttle
7. 25-158-11-S	Bushing, throttle linkage
8. M-545016-S	Screw, hex. flange M5x0.8x16
9. M-547050-S	Nut, hex. lock M5x0.8
10. 24-089-03-S	Spring, choke return
11. 24-126-56-S	Bracket, control
12. M-645016-S	Screw, hex. flange M6x1.0x16 (4)
13. 12-237-01-S	Clamp, cable (2)
14. 24-086-43-S	Screw, hex. flange M5x0.8x16 (2)
15. 24-090-07-S	Lever, throttle actuator
16. X-20-1-S	Washer, lock 1/4"
17. M-541050-S	Nut, hex. flange M5x0.8
18. 24-468-01-S	Washer, plain 5.5 mm (3)
19. 24-089-45-S	Spring, governor
20. M-446030-S	Nut, hex M4x0.7
21. 24-090-13-S	Lever, throttle control
22. M-545020-S	Screw, hex. flange M5x0.8x20
23. 24-089-51-S	Spring, throttle limiter
24. 24-090-05-S	Lever, choke
25. 41-468-03-S	Washer, spring 1/4"
26. M-403025-S	Screw, hex. cap M4x0.7x25
27. 24-079-05-S	Linkage, choke

OIL PAN/LUBRICATION

KEY PART NO. NO.	DESCRIPTION
1. 24-199-07-S	Pan, oil assembly (Includes 2-10)
2. M-645025-S	Screw, hex. flange M6x1.0x25 (2)
3. M-631005-S	Washer, plain 6 mm (2)
4. 24-393-08-S	Oil pump assembly (Includes 5)
5. 24-123-05-S	Tube, oil pickup
6. 24-162-26-S	Screen, oil
7. 24-043-12-S	Kit, governor gear w/pin (Includes 8)
8. 12-380-01-S	Pin, governor regulating
9. 52-448-02-S	Tab, locking
10. 12-144-02-S	Shaft, governor gear
11. 24-153-08-S	O-Ring
12. X-75-32-S	Plug, hex. ctsk. 3/8"
13. 24-136-01-S	Nipple, oil filter
14. 52-050-02-S	Filter, oil
15. 52-032-08-S	Seal, oil (PTO end)
16. 24-086-17-S	Screw, hex. flange M8x1.25x45
17. 24-086-16-S	Screw, hex. flange M8x1.25x45 (9)
18. X-75-10-S	Plug, sq. hd. solid 3/8" N.P.T.F.

NOTE: All component dimensions given in U.S. inches 1 inch = 25.4 mm

TRACTOR -- MODEL NUMBER 917.275012
KOHLER ENGINE-MODEL NUMBER CV674, TYPE NUMBER 75544

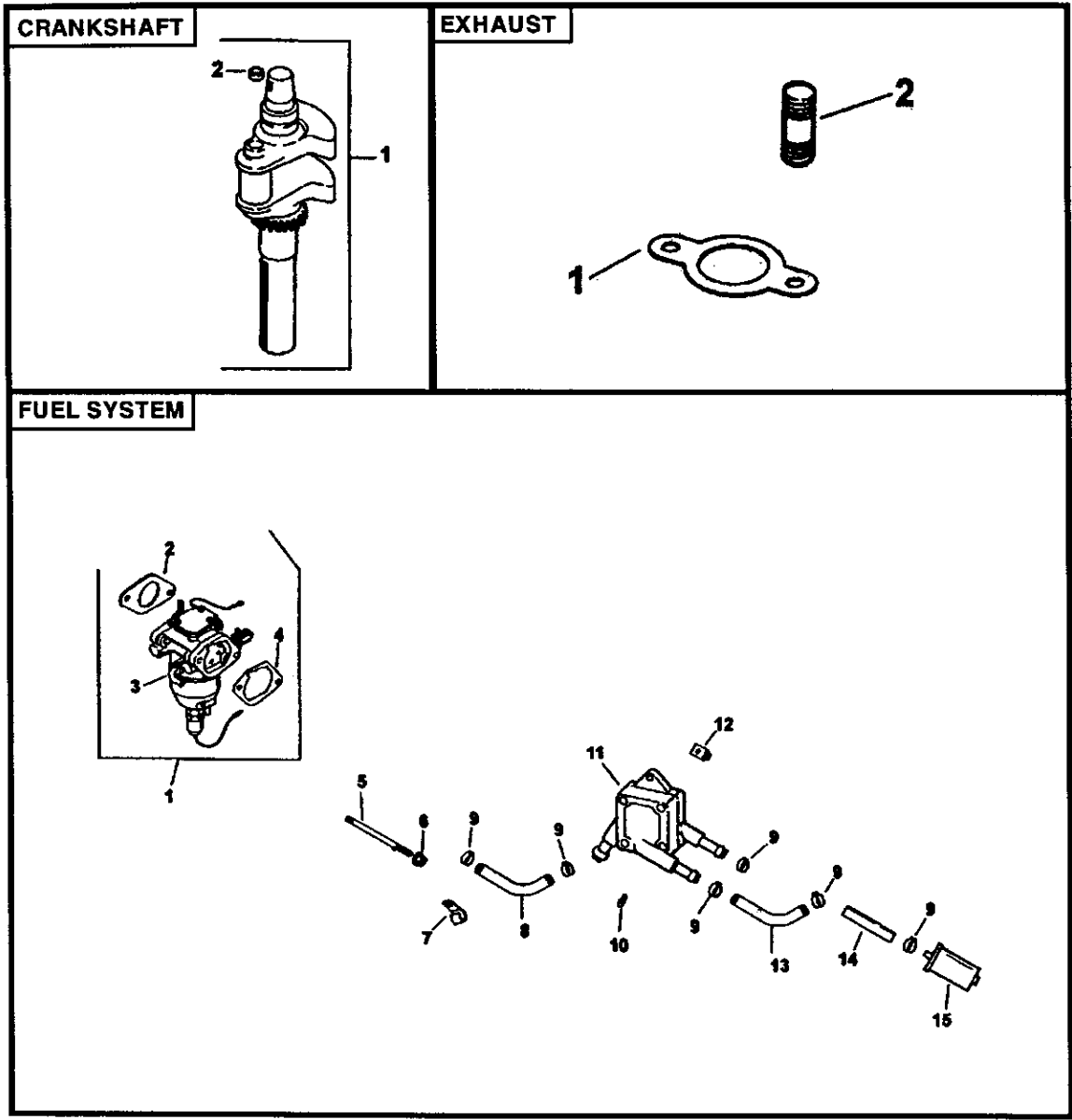

**TRACTOR -- MODEL NUMBER 917.275012
 KOHLER ENGINE-MODEL NUMBER CV674, TYPE NUMBER 75544**

CRANKSHAFT

**KEY PART
 NO. NO.**

DESCRIPTION

- 1. 24-014-72-S Crankshaft (Includes 2)
- 2. 52-139-09-S Plug, cup

EXHAUST

**KEY PART
 NO. NO.**

DESCRIPTION

- 1. 24-041-02-S Gasket, exhaust (2)
- 2. 25-072-04-S Stud, M8x1.25x33 (4)

- PA-75544 Replacement Engine
- 24 782 14 Miniblock
- 24 755 108-S Gasket Set

FUEL SYSTEM

**KEY PART
 NO. NO.**

DESCRIPTION

- 1. 24-853-61-S Kit, carburetor w/gaskets
(Includes 2-4)
- 2. 24-041-15-S Gasket, carburetor
- 3. 24-053-61 Carburetor assembly (For
information only not
available separately)
(Service with Kits 24 757 36-
S, 24 757 38-S)
- 4. 24 041 14-S Gasket, air cleaner base
- 5. M-629095-S Stud, M6x1.0x95 (2)
- 6. M-641060-S Nut, hex. flange M6x1.0 (2)
- 7. 47-154-01-S Clip, cable
- 8. 52-353-22-S Line, fuel 12"
- 9. 25-237-14-S Clamp, hose (6)
- 10. 24-086-12-S Screw, hex. cap. M6x1.7x18
(2)
- 11. 24-393-16-S Pump, fuel - pulse
- 12. 24-100-01-S Nut, plastic (2)
- 13. 24-353-03-S Line, fuel 10-5/8"
- 14. 15-353-04-S Line, fuel 11-1/2"
- 15. 24-050-02-S Filter, fuel

NOT ILLUSTRATED

- 24 757 36-S Kit, choke repair
- 24 757 38-S Kit, gasket repair

NOTE: All component dimensions given in U.S.
 inches 1 inch = 25.4 mm

SERVICE NOTES

SUGGESTED GUIDE FOR SIGHTING SLOPES FOR SAFE OPERATION

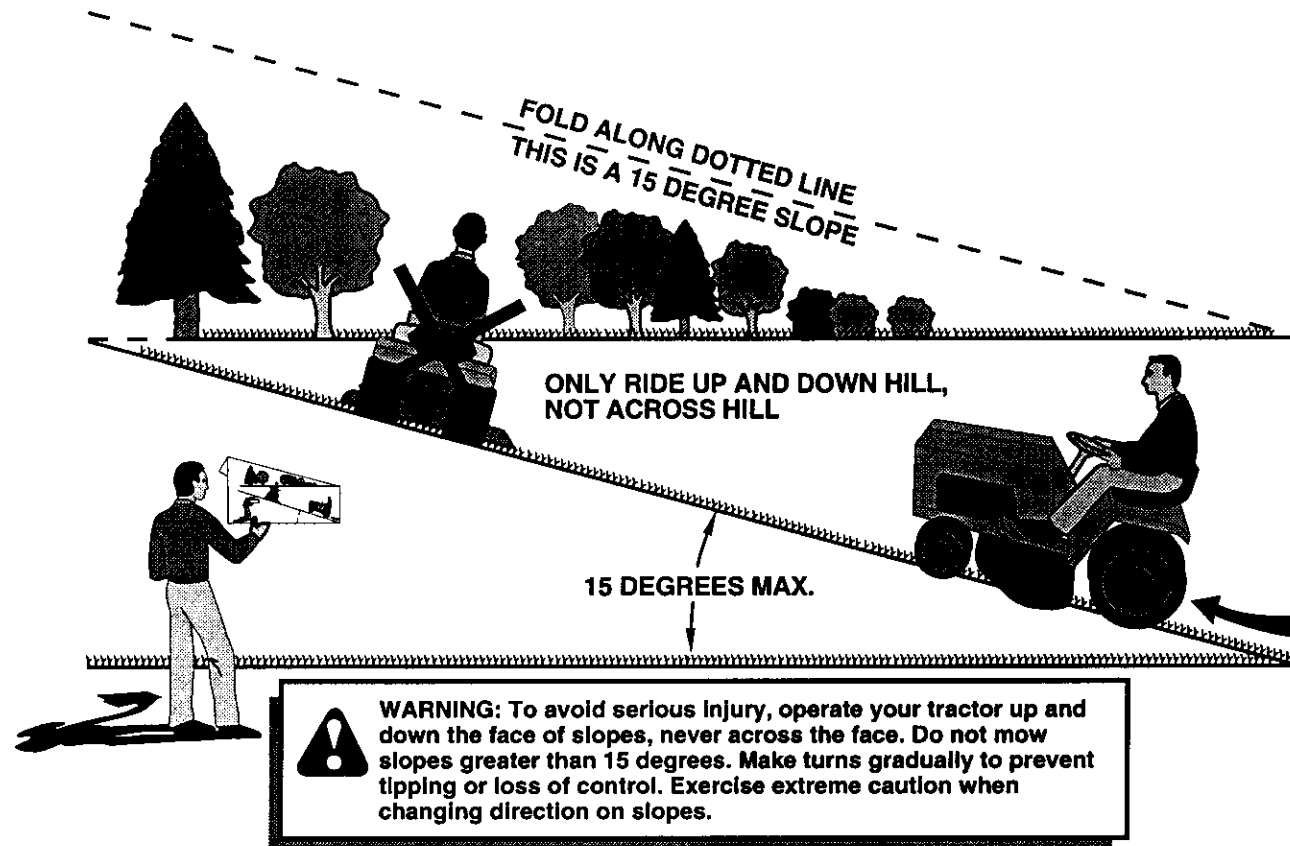

1. Fold this page along dotted line indicated above.
2. Hold page before you so that its left edge is vertically parallel to a tree trunk or other upright structure.
3. Sight across the fold in the direction of hill slope you want to measure.
4. Compare the angle of the fold with the slope of the hill.

Get it fixed, at your home or ours!

For repair of major brand appliances in your own home . . .
no matter who made it, no matter who sold it!

1-800-4-MY-HOME[®] Anytime, day or night
(1-800-469-4663) (U.S.A. and Canada)
www.sears.com www.sears.ca

For repair of carry-in products like vacuums, lawn equipment, and
electronics, call for the nearest **Sears Parts and Repair Center**.

1-800-488-1222 Anytime, day or night (U.S.A. only)
www.sears.com

For the replacement parts, accessories and owner's manuals
that you need to do-it-yourself, call **Sears PartsDirectSM**!

1-800-366-PART 6 a.m. – 11 p.m., 7 days a week
(1-800-366-7278) (U.S.A. only)
www.sears.com/partsdirect

To purchase or inquire about a Sears Service Agreement
or Sears Maintenance Agreement:

1-800-827-6655 (U.S.A.) **1-800-361-6665** (Canada)
7 a.m. – 5 p.m., CST, Mon. – Sat. 9 a.m. – 8 p.m. EST, M – F, 4 p.m. Sat.

Para pedir servicio de reparación a
domicilio, y para ordenar piezas:

1-888-SU-HOGARSM
(1-888-784-6427)

Au Canada pour service en français:

1-800-LE-FOYER^{MC}
(1-800-533-6937)
www.sears.ca



© Sears, Roebuck and Co.

® Registered Trademark / TM Trademark / SM Service Mark of Sears, Roebuck and Co.

® Marca Registrada / TM Marca de Fábrica / SM Marca de Servicio de Sears, Roebuck and Co.

^{MC} Marque de commerce / ^{MD} Marque déposée de Sears, Roebuck and Co.