

Panasonic®

Digital Camera Operating Instructions

Model No. **PV-SD4090**

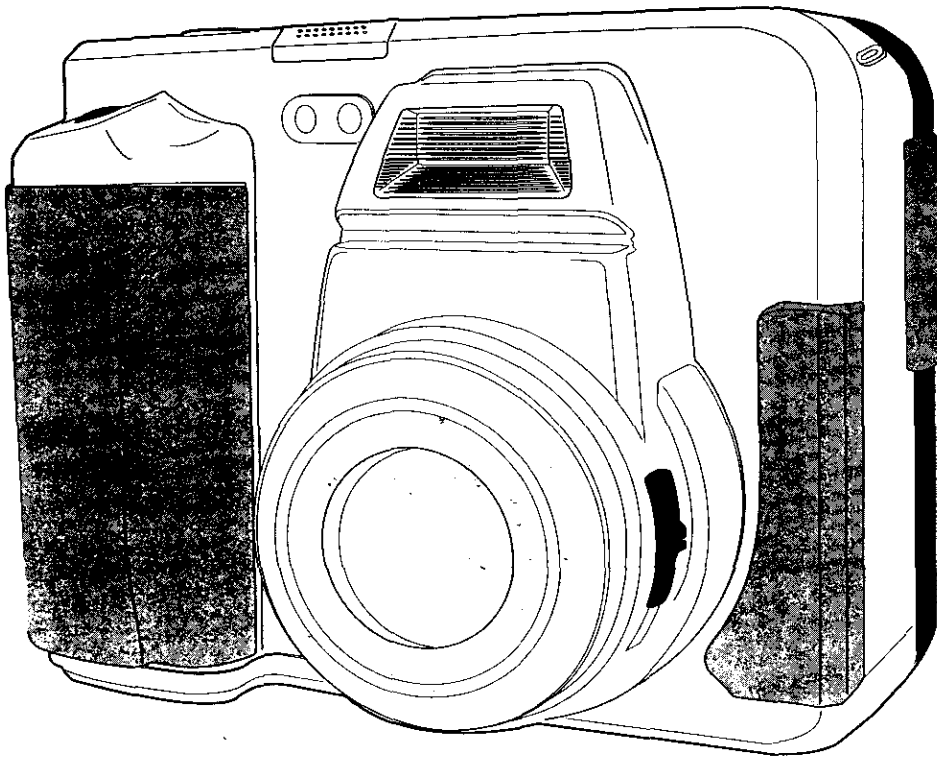

SUPER DISK™

 PalmCam®

For assistance, call 1-800-272-7033.

Before attempting to connect, operate or adjust this product, please read these instructions thoroughly, and keep them for future reference.

LSQT0179A

Things You Should Know

Attach your purchase receipt here

Thank you and congratulations

On your purchase of this state of the art Panasonic Digital Camera. This product has been manufactured and tested to Panasonic's highest standards to give you the best in performance and reliability. **Save this operating instruction manual** as an operating and information guide.

Date of Purchase

Dealer Purchased From

Dealer Address

Dealer Phone No.

Model No.

Serial No.

Unpack your Digital Camera

Please confirm that the following items are packed in the Digital Camera box. They are provided to help you use or set up your Digital Camera.

1pc. Digital Camera
(PV-SD4090)

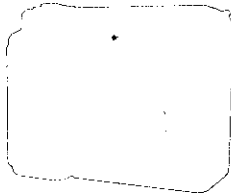

1 pc. AC Adaptor (LSSQ0219) with
AC Cable (VJAW0044)

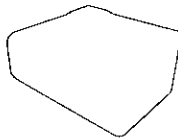

1pc. DC POWER
Cable (LSJA0277)



1 pc. USB Cable
(LSJA0265)



1pc. A/V Cable
(LSJA0278)



1pc. Lithium Ion
Battery Pack
(PV-DBP5)

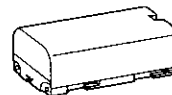

1pc. SuperDisk
Diskette (LSFT0188)



1pc. Camera Strap
(LSFC0013)



1pc. CD-ROM of USB Driver Software for Windows 98
and Macintosh / File Converter for Windows 95/98 /
QuickTime™ Software / Adobe PhotoDeluxe Software
for Windows 95/98 and Macintosh
(LSFT0189)

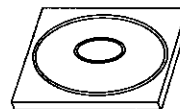

SuperDisk and the SuperDisk logo are trademarks of Imation Corporation. The Circle-Pyramid Logo is a registered trademark of Imation Corporation. Microsoft and Windows are registered trademarks of Microsoft in the United States and other countries.

Macintosh and iMac are registered trademark of Apple Computer Inc.

QuickTime and the QuickTime logo are trademarks used under license. QuickTime is registered in the US and other countries.

Adobe, the Adobe logo & PhotoDeluxe are trademarks of Adobe Systems Inc.

All product/brand names are trademarks or registered trademarks of the respective holders.

Safety Precautions

Getting Started

WARNING: TO PREVENT FIRE OR SHOCK HAZARD, DO NOT EXPOSE THIS EQUIPMENT TO RAIN OR MOISTURE.

Note: This equipment has been tested and found to comply with Part 15 of the FCC rules. These limits are designed to provide reasonable protection against harmful interference when operated in a residential environment.

If this equipment does cause interference to radio or television reception, which can be determined by turning the equipment off and on, use the equipment in another location and/or utilize an electrical outlet different from that used by the receiver.

If necessary, consult the dealer or an experienced radio/TV technician for help. You may find the booklet, 'Something About Interference' available from FCC local regional offices helpful.

FCC Warning:

To assure continued FCC compliance, use only the provided shielded interface cable with ferrite core when connecting digital camera to computer in accordance with instruction herein. Also, any unauthorized changes or modifications to this equipment could void the user's authority to operate.

Declaration of Conformity

Model Number : PV-SD4090
Trade Name : Panasonic
Responsibility Party : Matsushita Electric Corporation of America
Address : One Panasonic Way Secaucus New Jersey 07094
Telephone Number : 1-800-211-PANA (7262)

This device complies with Part 15 of the FCC Rules. Operation is subject to the following two conditions: (1) This device may not cause harmful interference, and (2) this device must accept any interference received, including interference that may cause undesired operation.

CAUTION:

UNIT IS A CLASS I LASER PRODUCT. HOWEVER THIS UNIT USES A VISIBLE LASER BEAM WHICH COULD CAUSE HAZARDOUS RADIATION EXPOSURE IF DIRECTED. BE SURE TO OPERATE THE UNIT CORRECTLY AS INSTRUCTED.

WHEN THIS UNIT IS PLUGGED TO THE WALL OUTLET. DO NOT PLACE YOUR EYES CLOSE TO THE OPENING OF THE DISC TRAY AND OTHER OPENINGS TO LOOK INTO THE INSIDE OF THIS UNIT.

USE OF CONTROLS OR ADJUSTMENTS OR PERFORMANCE OF PROCEDURES OTHER THAN THOSE SPECIFIED. HEREIN MAY RESULT IN HAZARDOUS RADIATION EXPOSURE.

DO NOT OPEN COVERS AND DO NOT REPAIR YOURSELF. REFER SERVICING TO QUALIFIED PERSONNEL.

CAUTION:

LASER RADIATION WHEN OPEN.
DO NOT STARE INTO BEAM.

ATTENTION:

RAYONNEMENT LASER EN CAS
D'OUVERTURE.
NE PAS REGARDER DANS LE
FAISCEAU.

(inside of product)

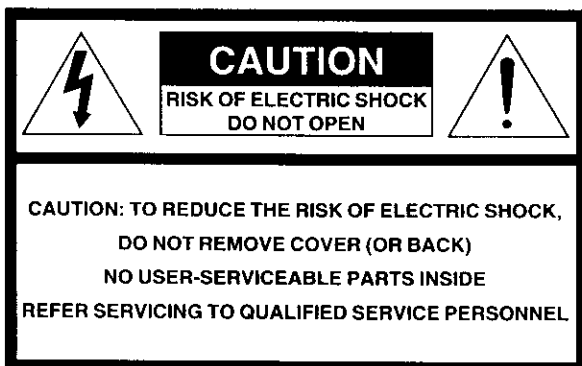

CAUTION
RISK OF ELECTRIC SHOCK
DO NOT OPEN

**CAUTION: TO REDUCE THE RISK OF ELECTRIC SHOCK,
DO NOT REMOVE COVER (OR BACK)
NO USER-SERVICEABLE PARTS INSIDE
REFER SERVICING TO QUALIFIED SERVICE PERSONNEL.**



This symbol warns the user that uninsulated voltage within the unit may have sufficient magnitude to cause electric shock. Therefore, it is dangerous to make any kind of contact with any inside part of this unit.



This symbol alerts the user that important literature concerning the operation and maintenance of this unit has been included. Therefore, it should be read carefully in order to avoid any problems.

The above markings are located on the appliance bottom cover.

Important Safeguards

1. **Read Instructions** — All the safety and operating instructions should be read before the unit is operated.
2. **Retain Instructions** — The safety and operating instructions should be retained for future reference.
3. **Heed Warnings** — All warnings on the unit and in the operating instructions should be adhered to.
4. **Follow Instructions** — All operating and maintenance instructions should be followed.
5. **Cleaning** — Unplug this video unit from the wall outlet before cleaning. Do not use liquid or aerosol cleaners. Use a dry cloth for cleaning.
6. **Attachments** — Do not use attachments not recommended by the video product manufacturer as they may be hazardous.
7. **Water and Moisture** — Do not use this video unit near water — for example near a bath tub, wash bowl, kitchen sink, or laundry tub, in a wet basement, or near a swimming pool, and the like.
8. **Accessories** — Do not place this video unit on an unstable cart, stand, tripod, bracket, or table. The video unit may fall, causing serious injury to a child or adult, and serious damage to the unit. Use only with a cart, stand, tripod, bracket, or table recommended by the manufacturer, or sold with the video unit. Any mounting of the unit should follow the manufacturer's instructions and should use a mounting accessory recommended by the manufacturer. An appliance and cart combination should be moved with care. Quick stops, excessive force, and uneven surfaces may cause the appliance and cart combination to overturn.
9. **Ventilation** — Slots and openings in the cabinet are provided for ventilation and to ensure reliable operation of the video unit and to protect it from overheating. These openings must not be blocked or covered. Never place the video unit on a bed, sofa, rug, or other similar surface, or near or over a radiator or heat register. This video unit should not be placed in a built-in installation such as a bookcase or rack unless proper ventilation is provided or the manufacturer's instructions have been adhered to.
10. **Power Sources** — This video unit should be operated only from the type of power source indicated on the marking label. If you are not sure of the type of power supply to your home, consult your appliance dealer or local power company. For video units intended to be operated from battery power, or other sources, refer to the operating instructions.
11. **Grounding or Polarization** — This video unit may be equipped with either a polarized 2-wire AC (Alternating Current) line plug (a plug having one blade wider than the other) or 3-wire grounding type plug, a plug having a third (grounding) pin.
The 2-wire polarized plug will fit into the power outlet only one way. This is a safety feature. If you are unable to insert the plug fully into the outlet, try reversing the plug. If the plug still fails to fit, contact your electrician to replace your obsolete outlet. Do not defeat the safety purpose of the polarized plug.
The 3-wire grounding type plug will fit into a grounding type power outlet. This is a safety feature. If you are unable to insert the plug into the outlet, contact your electrician to replace your obsolete outlet. Do not defeat the safety purpose of the grounding type plug.
12. **Power-Cord Protection** — Power-supply cords should be routed so that they are not likely to be walked on or pinched by items placed upon or against them, paying particular attention to cords of plugs, convenience receptacles, and the point where they exit from the unit.
13. **Lightning** — For added protection of this video unit receiver during a lightning storm, or when it is left unattended and unused for long periods of time, unplug it from the wall outlet and disconnect the antenna or cable system. This will prevent damage to the video unit due to lightning and power-line surges.
14. **Overloading** — Do not overload wall outlets and extension cords as this can result in a risk of fire or electric shock.
15. **Objects and Liquids** — Never push objects of any kind into this video unit through openings as they may touch dangerous voltage points or short out parts that could result in a fire or electric shock. Never spill liquid of any kind onto the video unit.
16. **Servicing** — Do not attempt to service this video unit yourself as opening or removing covers may expose you to dangerous voltage or other hazards. Refer all servicing to qualified service personnel.



Important Safeguards

17. **Damage Requiring Service** — Unplug this video unit from the wall outlet and refer servicing to qualified service personnel under the following conditions:
 - a. When the power-supply cord or plug is damaged.
 - b. If any liquid has been spilled onto, or objects have fallen into the video unit.
 - c. If the video unit has been exposed to rain or water.
 - d. If the video unit does not operate normally by following the operating instructions. Adjust only those controls that are covered by the operating instructions, as an improper adjustment of other controls may result in damage and will often require extensive work by a qualified technician to restore the video unit to its normal operation.
 - e. If the video unit has been dropped or the cabinet has been damaged.
 - f. When the video unit exhibits a distinct change in performance — this indicates a need for service.
18. **Replacement Parts** — When replacement parts are required, be sure the service technician has used replacement parts specified by the manufacturer or have the same characteristics as the original part. Unauthorized substitutions may result in fire, electric shock or other hazards.
19. **Safety Check** — Upon completion of any service or repairs to this video unit, ask the service technician to perform safety checks to determine that the video unit is in safe operating order.

Precautions

USE & LOCATION

- **TO AVOID SHOCK HAZARD ...** Your Digital Camera and power supply should not be exposed to rain or moisture. Do not connect the power supply or operate your Digital Camera if it gets wet. Your Digital Camera has been designed for outdoor use, however it is not designed to sustain direct exposure to water, rain, sleet, snow, sand, dust, or a direct splashing from a pool or even a cup of coffee. This action could permanently damage the internal parts of your Digital Camera. Do not attempt to disassemble this unit. There are no user serviceable parts inside. Unplug your Digital Camera from the power supply and have it serviced.
- **DO NOT AIM YOUR DIGITAL CAMERA AT THE SUN OR OTHER BRIGHT OBJECTS.**
- **DO NOT EXPOSE YOUR DIGITAL CAMERA TO EXTENDED HIGH TEMPERATURE ...** Such as, in direct sunlight, inside a closed car, next to a heater, etc... This action could permanently damage the internal parts of your Digital Camera.
- **AVOID SUDDEN CHANGES IN TEMPERATURE ...** If the unit is suddenly moved from a cold place to a warm place, moisture may form inside the unit.
- **DO NOT LEAVE YOUR DIGITAL CAMERA OR THE POWER SUPPLY TURNED ON WHEN NOT IN USE.**
- **STORAGE OF YOUR DIGITAL CAMERA ...** Store and handle your Digital Camera in a manner that will not subject it to unnecessary movement (avoid shaking and striking). Your Digital Camera contains a sensitive pick-up device which could be damaged by improper handling or storage.

CARE

- **TO CLEAN YOUR DIGITAL CAMERA ...** Do not use strong or abrasive detergents when cleaning your Digital Camera body.
- **TO PROTECT THE LENS ...** Do not touch the surface of the lens with your hand. Use a commercial Digital Camera lens solution and lens paper when cleaning the lens. Improper cleaning can scratch the lens coating.
- **TO PROTECT THE FINISH OF YOUR DIGITAL CAMERA ...** Before handling your Digital Camera, make sure your hands and face are free from any chemical products, such as suntan lotion, as it may damage the finish.

Table of Contents

Getting Started

Things You Should Know	2
Safety Precautions	3
Important Safeguards	4
Precautions	5
Special Digital Camera Features	7
Index of Controls	8
On Screen Display (OSD)	10
LCD Monitor Indication	11
Power Supply	13
Attaching the Camera Strap	16
Inserting the SuperDisk™ Diskette or Floppy Disk	17
Operating the MENU Screen	19
Setting the Clock	21

Basic Operation

Capturing Images	22
Adjusting LCD Viewfinder Brightness	28
Playing Back Captured Images	29
Viewing Images on a TV Screen and Transferring Images to a VCR	33

Special Features

Using the Built-in Flash	34
White Balance	35
Light Metering	36
Self Timer Recording	37
Adjusting the Iris Manually	38
Time Lapse Recording	39
To Delete Specific Images	40
Formatting the Disk Media	41
To Copy Image Pages	42
To Copy All Images	43
Slide Show	44
Transferring Your Images (Windows 98)	45
Transferring Your Images (Macintosh)	54
SuperDisk Drive	61
Using the SuperDisk Drive (Windows 98)	62
Using the SuperDisk Drive (Macintosh)	64
Using the SuperDisk Drive	65
Print Mark	66

For Your Information

Digital Camera Accessory	67
Digital Camera Accessory Order Form	68
Before Requesting Service	69
Warning Indications	70
Specifications	72
Warranty	73
Service Center Directory	74
Index	75

Special Digital Camera Features

Getting Started



Our PV-SD4090 enables you to capture and save a large amount of image data using the memory storage of the SuperDisk Drive. Image data can be easily transferred to your Personal Computer using the USB interface.

- 1.3 Mega Pixel CCD
- Removable 120MB SuperDisk™ Diskette (stores up to 1,500 shots on one diskette)
- Floppy Disk Compatible
- Easy Connection to a PC using a USB interface
- Use as an External Storage Device for a PC
- 2.5 in. TFT LCD Display
- Audio Capability
- Still image, Burst, Motion Image, and Time Lapse Recording Capability
- DPOF Compatible
- A/V Out
- Lithium Ion Battery

Note

- Do not subject unit to a strong impact during record or playback. Unit may not function normally.
- Do not use in extreme heat (104 °F and above). This may damage the disk. Also, in extremely hot places (104 °F and above), remove the disk from the camera and store to avoid damaging disk.
- **Be sure to make a backup copy of important data.**

Index of Controls

Front View

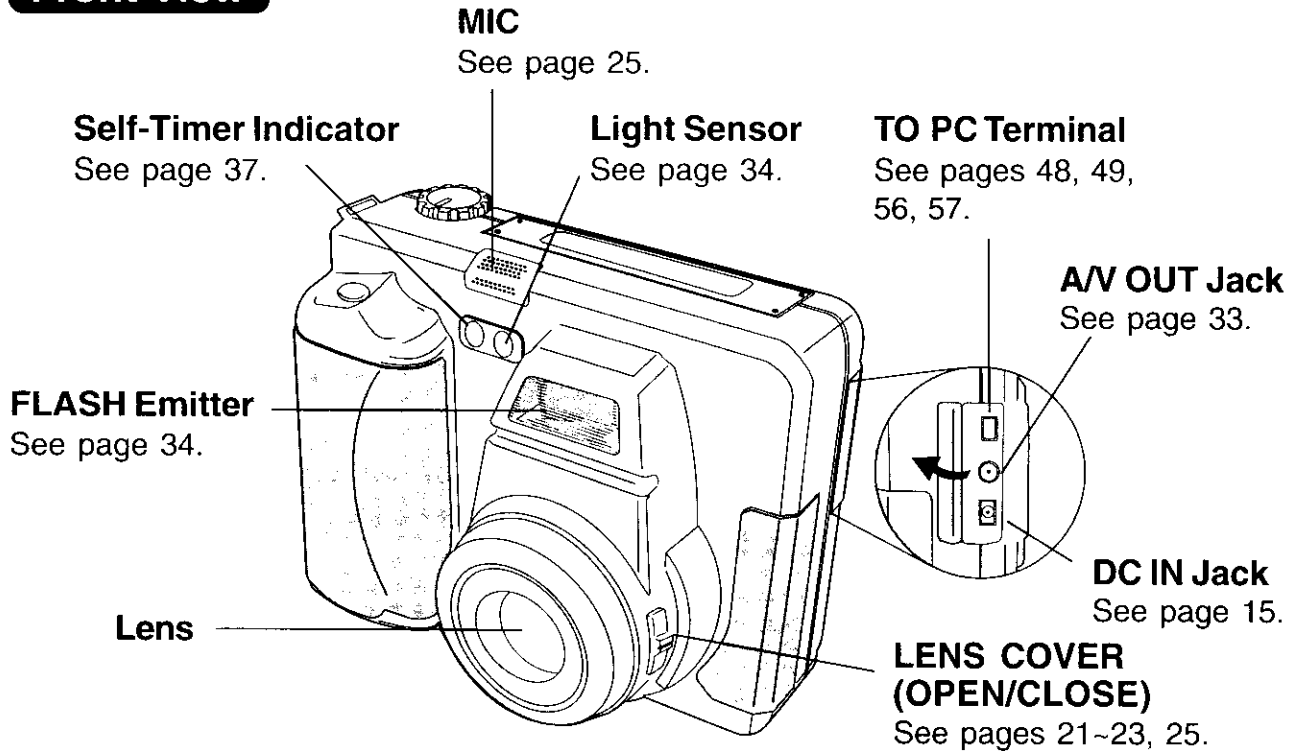

Rear View

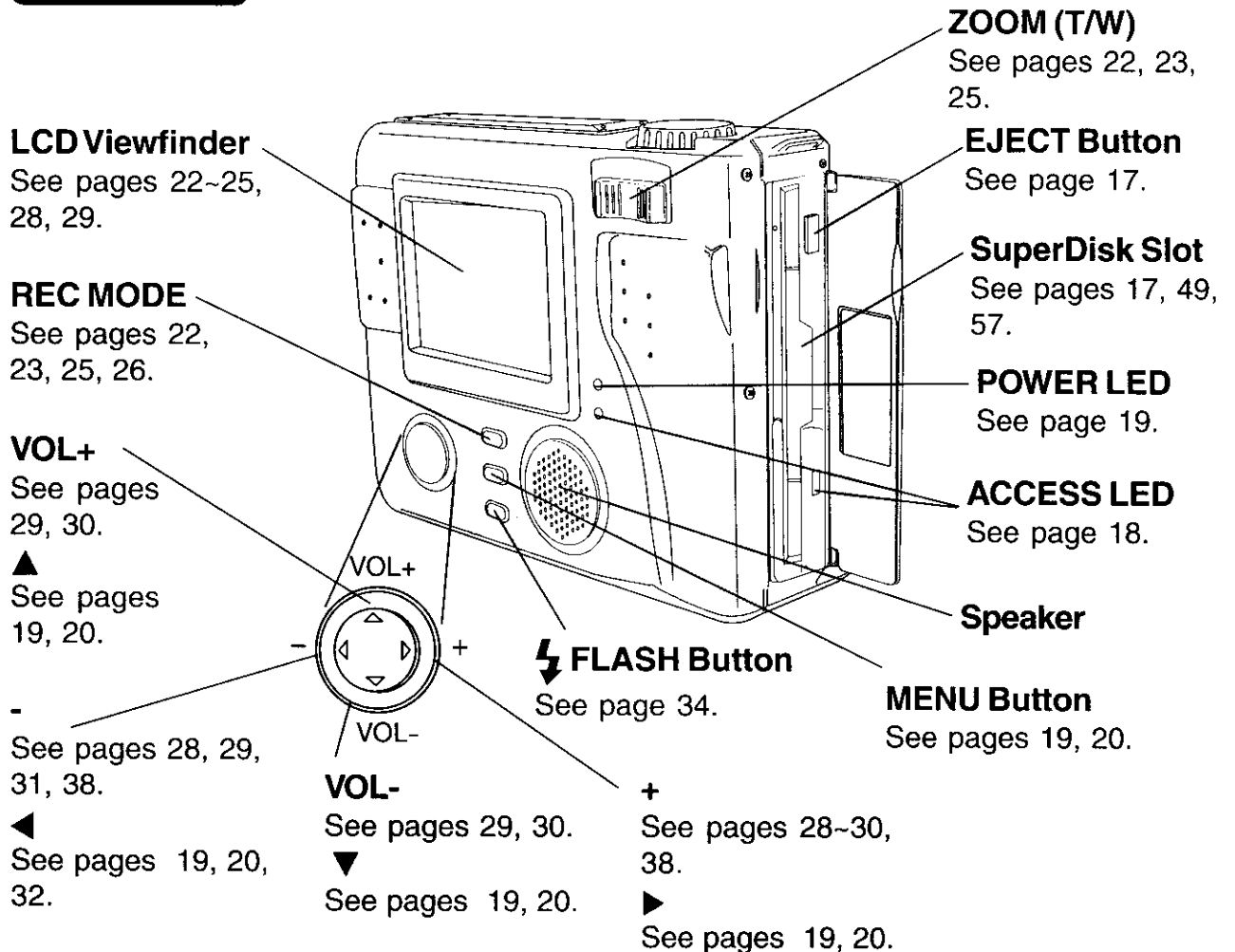

Index of Controls

Top View

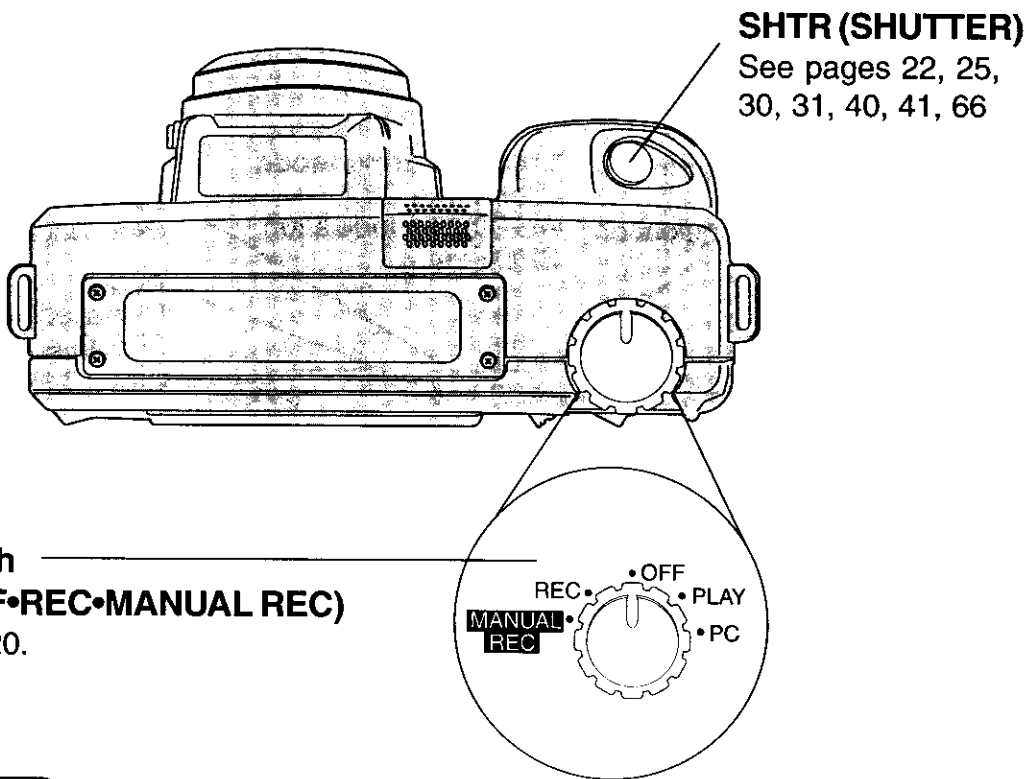

Bottom View

Battery Compartment
See page 14.

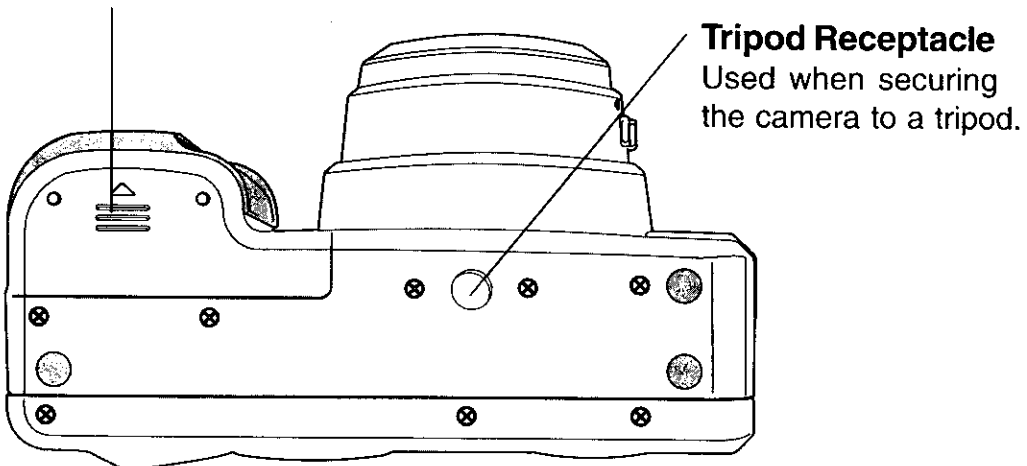

On Screen Display (OSD)

The indication displayed on the LCD screen will tell you the operation status of the Digital Camera.

REC OSD

White Balance Mode

(See page 35.)

AUTO : No Indication
 INDOOR : ☆
 OUTDOOR : ✨
 WHITE SET: WS

Light Metering Mode

(See page 36.)

AUTO: No Indication
 SPOT : □

Self-Timer Mode

(See page 37.)

Audio

Displayed when image with AUDIO is recorded.
 (See pages 23, 25.)

Flash Mode

(See page 34.)

AUTO : No Indication
 ON : ⚡
 RED EYE: 👁
 OFF : ☹



SLOW

(See pages 22, 23.)

Displayed If SLOW SHUTTER is set to ON in the MENU screen.

Image Pages left in memory

Recording Mode :

SF(Super Fine), F(Fine), N(Normal),
 ZOOM(Zoom),  (Motion Image Rec Mode),
 (Burst Rec Mode).
 (See page 26.)

REC

Displayed when image is recorded.

Low Light Warning

"LIGHT" will appear when the light level is inadequate. In this case, more light should be provided or use flash to achieve better picture quality and color.

Date/Time Indication

(See page 21.)

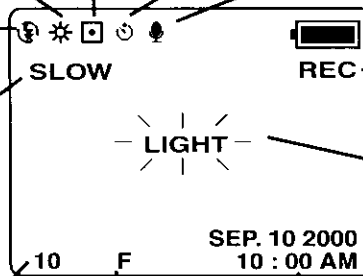

PLAY OSD

Print Number
 (See page 66.)

Print Mark
 (See page 66.)

Directory/
 Image Number

AUDIO

Displayed when image with AUDIO is played.
 Not displayed when movie is played. (See pages 29, 30.)

Battery Condition

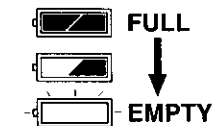

As the Battery is depleted, the indication changes.

POWER LED will flash when battery is empty.

Displayed Image Page and its captured mode SF(Super Fine), F(Fine), N(Normal), or  (Motion Image Rec Mode).

• If the image is captured in ZOOM or  (Burst Rec Mode), the displayed image mode will be N(Normal).

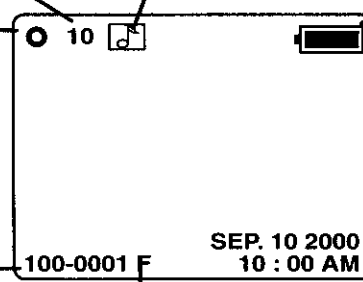

LCD Monitor Indication

Recording Menu

< REC Mode >

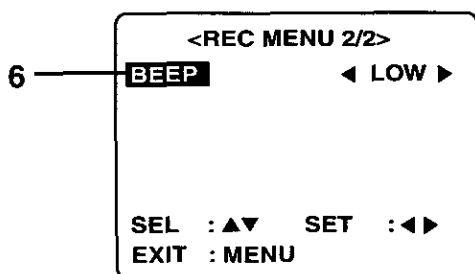
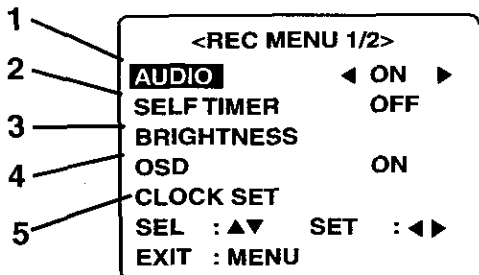

< MANUAL REC Mode >

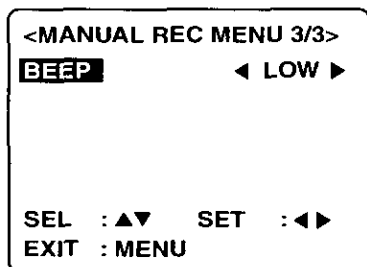
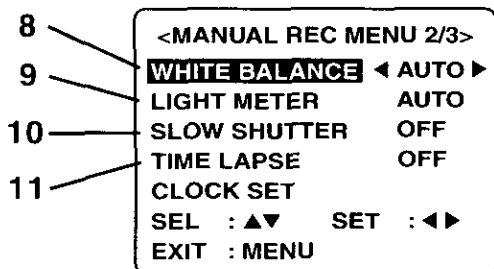
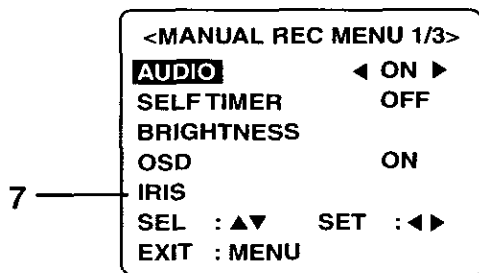

- AUDIO** (See Pages 23, 25, 29, 30.)
To select audio recording on/off.
- SELF TIMER** (See Page 37.)
To set Self Timer.
- BRIGHTNESS** (See Page 28.)
To adjust LCD Viewfinder brightness.
- OSD** (See Pages 10, 12.)
To select OSD display on/off.
- CLOCK SET** (See Page 21.)
To set clock.
- BEEP** (See Page 27.)
To select beep mode when capturing images.

- IRIS** (See Page 38.)
To adjust Iris manually.
- WHITE BALANCE** (See Page 35.)
To change to one of the 4 White Balance modes.
- LIGHT METER** (See Page 36.)
To change to AUTO or SPOT.
- SLOW SHUTTER** (See Pages 22, 23.)
To select slow shutter. By changing the shutter speed, you can capturing a more beautiful image also in a comparatively dark place.
- TIME LAPSE** (See Page 39.)
To set time lapse recording.

LCD Monitor Indication

Playback Menu

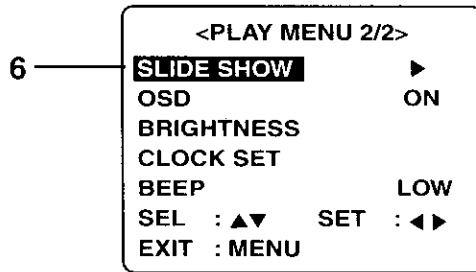
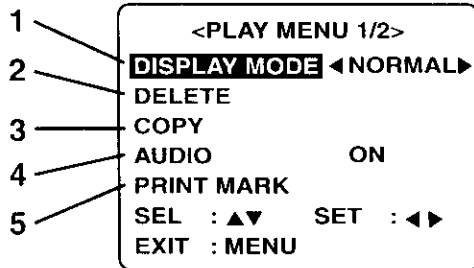

1. **DISPLAY MODE** (See Pages 29, 30, 32.)
Select playback mode.
2. **DELETE** (See Pages 40, 41.)
Delete image from SuperDisk Diskette or Floppy Disk.
3. **COPY** (See Pages 42, 43.)
To set copy.
4. **AUDIO** (See Pages 29, 30.)
To select audio on/off when playing back.
5. **PRINT MARK** (See Page 66.)
To set print mark.
6. **SLIDE SHOW** (See Page 44.)
Playback images as slide show.

On Screen Display Order

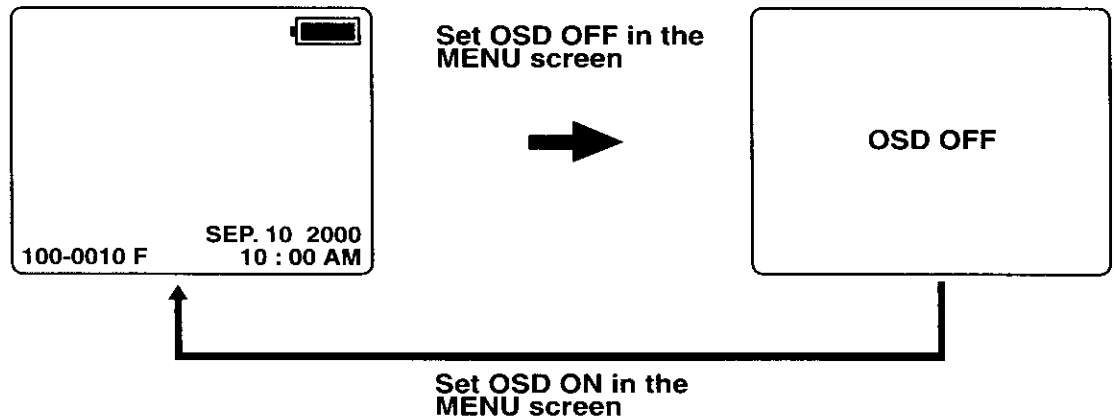

Note

- Press MENU to display MENU screen, and then select OSD: ON. If you select OFF, OSDs will not be displayed.

Charge the Battery Pack on the AC Adaptor

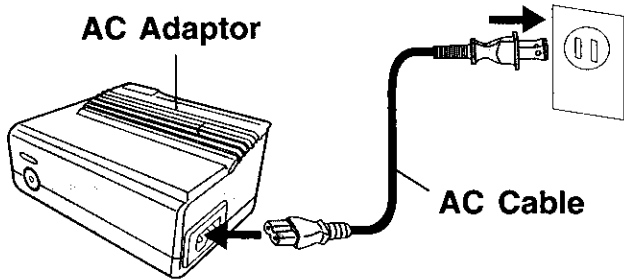

- 1** Connect AC Cable (supplied) to AC IN on the AC Adaptor and plug the AC Adaptor into an AC outlet.
 - POWER LED lamp will light.
 - Disconnect DC Cable if it is connected to AC Adaptor.

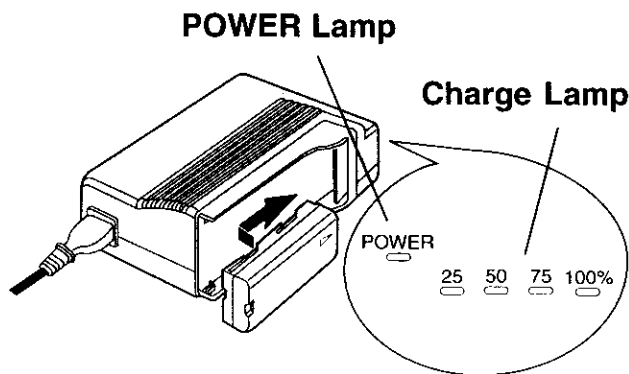

- 2** Attach the battery as shown to charge.
 - Charge Lamps on the AC Adaptor will flash and then turn solid green to indicate current charge level. When all 4 lamps are constantly on, the battery is fully charged. (approx. 1 hour 20 minutes.)

- 3** Remove the Battery.
Slide the Battery out and then lift up.

About the Charge Lamps

- The four Charge Lamps “25%”, “50%”, “75%” and “100%” flash and then remain lit one after another to indicate how much the Battery has been charged. When all four lamps are lit, charging is finished.
- The Charge Lamps give a good approximate indication of the charging condition under normal ambient temperature. However, when charging at high or low temperature, the charge lamps may differ considerably from the actual charging condition.

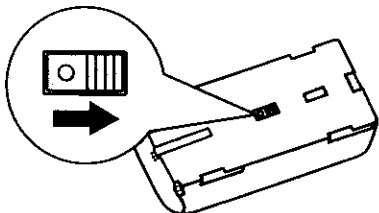

Battery Charging Confirmation Marker

Use this marker as a reminder to yourself when the battery is fully charged or in need of a charge. This marker performs no function and is for your reference only.

- The Battery is no longer serviceable if the operation time is very short, even after a sufficient charge.

Power Supply

Loading the Lithium Battery

Bottom View

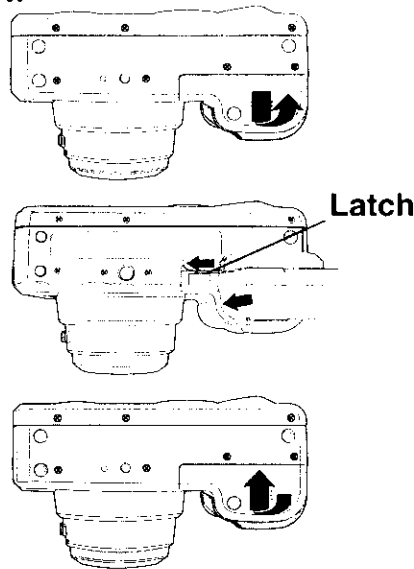

- 1** Slide the Battery Compartment lid in the direction of the arrow and swing it open.
- 2** While sliding Latch, insert the Lithium Ion Battery until it locks into place.
 - Be sure to use a Lithium Ion Battery. Be sure that the direction of the arrow on the battery is facing down when inserting it into the camera.
- 3** Swing the Battery Compartment lid down and slide it shut.

WARNING! Do not dispose of in fire, put in backwards, disassemble, or short circuit; otherwise battery may leak or burst, causing possible personal injury.

Battery Notes

Caution:

- Charge only with specified charger.
- The Battery can be charged within a temperature range of 32° F (0° C) and 104° F (40° C).
- The Battery may be warm after charging or just after use. This is normal.
- Do not use an insufficiently charged or worn out Battery.
- In extreme cold surroundings, Battery charging time will increase.

Safety precautions:

- Do not get the Battery near, or dispose of in fire.
- Do not directly connect (short circuit) the positive (+) and negative (–) terminals.
- Never attempt to disassemble or reassemble the Battery.

To avoid damage to the Battery:

- Do not drop or jar the Battery.
- Use the Battery with specified models only.
- If the Battery is used in extremely high temperatures, a safety device will automatically prevent operation.

To insure longer battery life:

- **While not in use, remove Battery from the Digital Camera and AC Adaptor and store in a cool, dark, dry place.** If you leave the Battery in the Digital Camera or on the AC Adaptor for a long time, the Battery will no longer be rechargeable.
- Keep the Battery terminals clean.

Operation Time

When using the supplied Panasonic Lithium Ion Batteries, you will have a maximum of about 200 images (at an ambient temperature of 25 ° C).

- Capturing an image every 30 seconds.
- Using Flash once for every other capture.
- Recording mode is Fine.

CAUTION

Replace with Panasonic PV-DBP5 or CGR-B/202A1B only. Use of another battery may present a risk of fire or explosion. **Caution**-battery may explode if mistreated.

Do not recharge, disassemble or dispose of in fire. Keep battery out of reach of children. Danger of explosion if battery is incorrectly inserted. Dispose of used battery promptly.

Using AC Adaptor

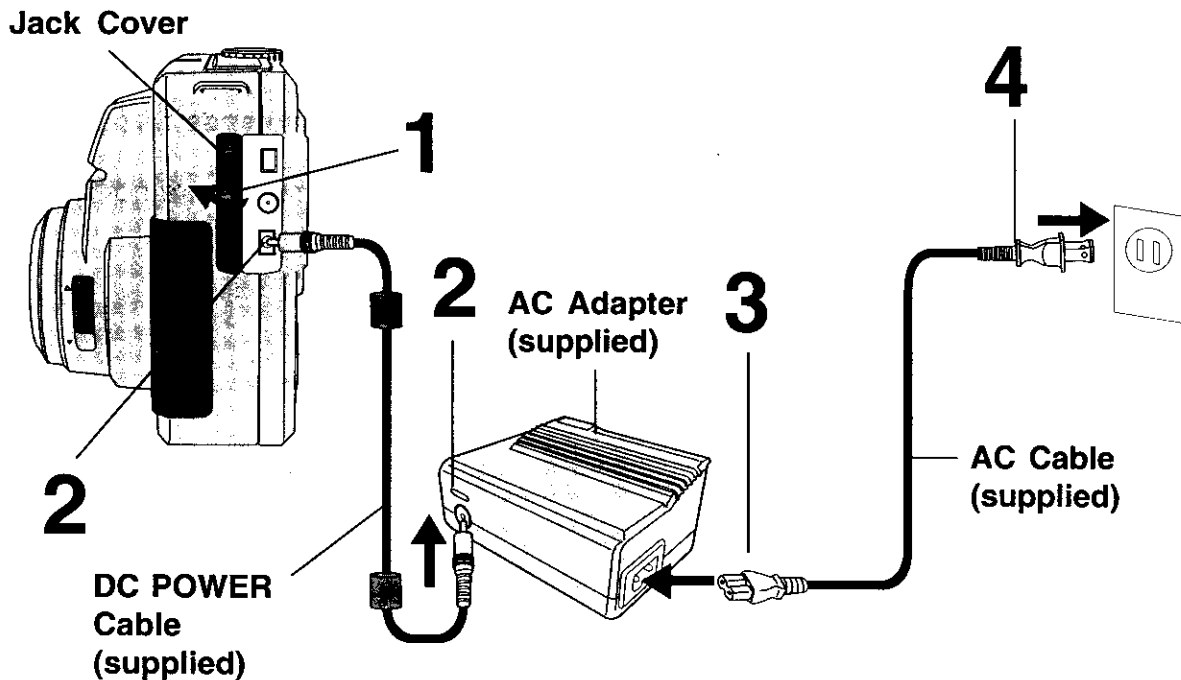

- 1** Pull up the Jack Cover.
- 2** Connect DC POWER Cable (supplied) to DC OUT on the AC Adaptor and DC IN on the Digital Camera.
- 3** Connect AC Cable (supplied) to AC IN on the AC Adaptor.
- 4** Plug the AC Adaptor into an AC outlet.

Note

- While not in use, unplug the AC Adaptor from the AC outlet.
- Use the supplied Panasonic AC Adaptor.
- Do not connect AC Adaptor after turning POWER on.
- When the DC Cable is connected during charging, the power supply is given priority and charging will not be possible.

Attaching the Camera Strap

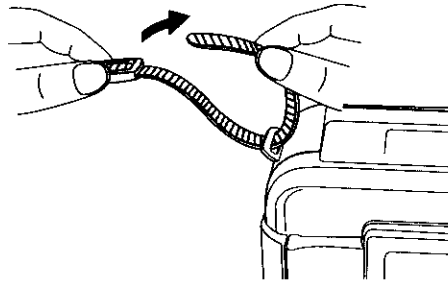

1 Thread the strap ends through the Strap Attachment Rings.

2 Reinsert the strap ends through their buckles.
• Make sure the straps are not twisted.

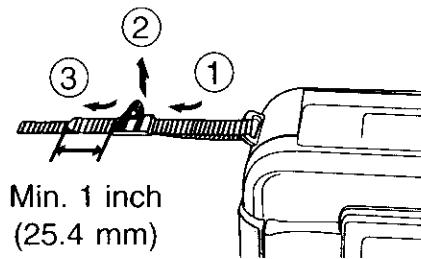

Adjust the Length

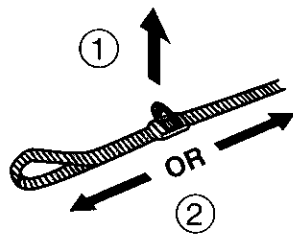

1 Loosen the strap from the Buckle and create a loop.

2 Pull the strap firmly through the Buckle to shorten or lengthen the strap.

Inserting the SuperDisk™ Diskette or Floppy Disk

Inserting the Disk Media:

- The captured images will be stored on the Disk Media.
- Be sure to insert the Disk Media before using the camera.

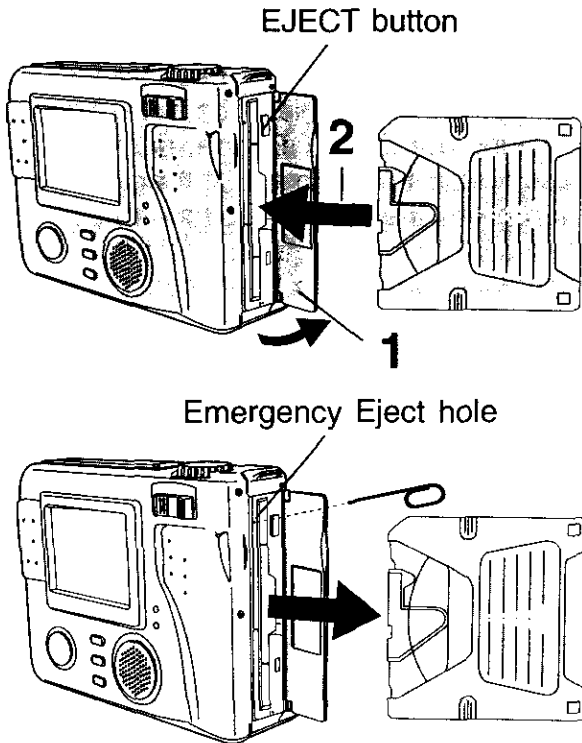

- 1** Open the cover. Insert the Disk Media.
- 2** Push the Disk Media fully into the SuperDisk Drive.

Removing the Disk Media:

Set the POWER Switch to REC, PLAY or PC. Push the EJECT button so the Disk Media pops out. (Be careful not to drop the Disk Media.)

Emergency Ejection of the Disk Media:

If, for some reason, the Disk Media does not eject automatically, you can eject manually. (Turn POWER OFF before proceeding.) Insert a straightened paper clip, etc., (diameter = 1~1.5 mm, min. length = 30 mm) into the Emergency Eject hole.

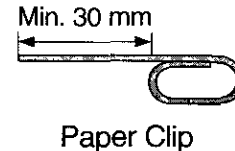

Using a Floppy Disk

A Floppy Disk (not supplied) which has been formatted to Windows on your Floppy Disk Drive can be used in the SuperDisk Drive. (See pages 61, 64.)

When using a new Floppy Disk, it is recommended that the Disk be inserted into the Digital Camera and formatted (Quick Format).

If a read error occurs in the PC Floppy Disk Drive, use the Digital Camera to read the data.

SuperDisk Diskette	120MB Format
Floppy Disk (2HD)	1.44MB Format

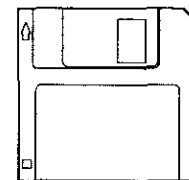
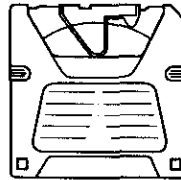

*SuperDisk Diskette *Floppy Disk (2HD)

***The SuperDisk Diskette is only supported by Windows® 98 or Mac OS 8.1 or later. For other operating systems, you should use Floppy Disk.**

Note

- Only DOS formatted floppy disks can be used with this Camera. Macintosh OS formatted floppy disks must be re-formatted to DOS with this camera.
- You can use this unit as a SuperDisk Drive. (See pages 48, 56.)
- The SuperDisk Diskette is only used for SuperDisk Drive.
- To format the Disk Media, see pages 62, 64.

Inserting the SuperDisk™ Diskette or Floppy Disk

Note

- Do not bend, drop, apply high pressure or subject the Disk Media to strong shocks.
- Do not store it in places with high temperature, high humidity, a lot of dust, or static electricity and strong electromagnetic waves.
- Keep the Disk Media's contacts free from dust, water or other foreign substances. Do not touch them with your fingers, etc.
- Do not disassemble or deform the Disk Media.
- Be sure to make a backup copy of important data.
- Make sure that you do not insert the Disk Media in the wrong direction.
- Do not, under any circumstances, eject the Disk Media immediately after pressing the SHUTTER Button (during recording of an image) or while deleting (when "PLEASE WAIT" is displayed). This could damage the format of the Disk Media and make them unusable.
- When the Disk Media does not eject after pressing the EJECT Button, push the Disk Media fully into the slot again and then press the EJECT Button firmly.
- "NO DISK" will appear on the LCD Viewfinder when the Disk Media is not inserted.
- "DISK ERROR" will appear on the LCD Viewfinder if the Disk Media is defective.

Caution

- The ACCESS LED lamp will flash when the Digital Camera is accessing the Disk Media. Please never expose this unit to large vibrations or impacts while ACCESS LED lamp is flashing. And, do not turn off the Power, take out a Disk Media, or remove the battery when ACCESS LED lamp is flashing.

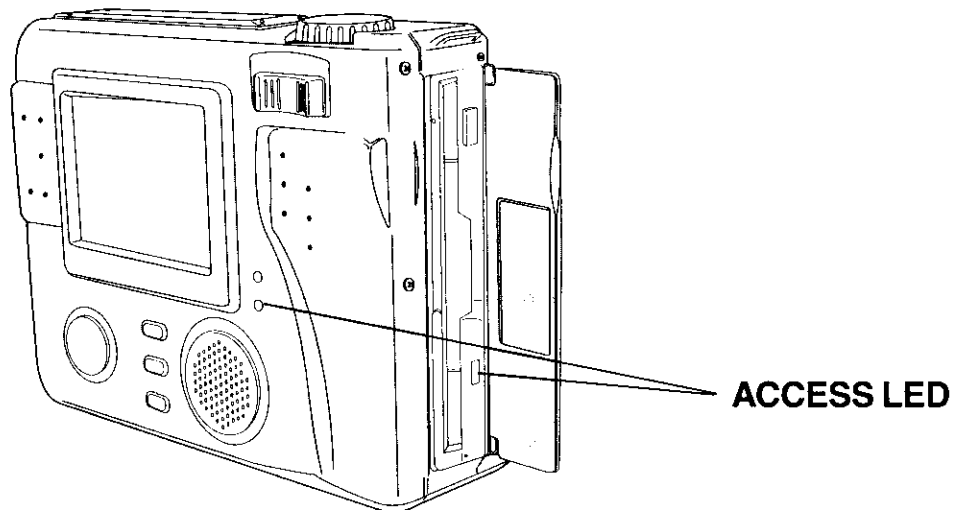

For additional information regarding Imation SuperDisk products, please call 1-888-466-3456.

Operating the MENU Screen

How to operate the MENU screen

Please refer to pages 11~12 for explanation of each menu item.

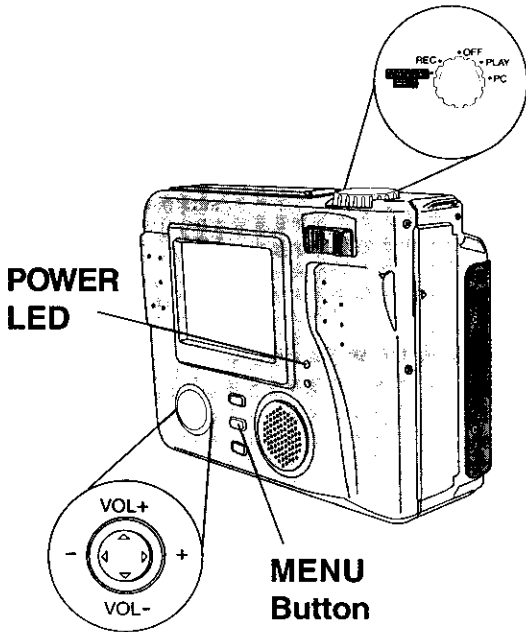

Example of Menu Screens

<REC menu>

```
<REC MENU 1/2>
AUDIO      ◀ ON ▶
SELFTIMER  OFF
BRIGHTNESS
OSD        ON
CLOCK SET
SEL : ▲▼  SET : ◀▶
EXIT : MENU
```

<MANUAL REC menu>

```
<MANUAL REC MENU 1/3>
AUDIO      ◀ ON ▶
SELFTIMER  OFF
BRIGHTNESS
OSD        ON
IRIS
SEL : ▲▼  SET : ◀▶
EXIT : MENU
```

<PLAY menu>

```
<PLAY MENU 1/2>
DISPLAY MODE ◀NORMAL▶
DELETE
COPY
AUDIO      ON
PRINT MARK
SEL : ▲▼  SET : ◀▶
EXIT : MENU
```

When selecting REC mode

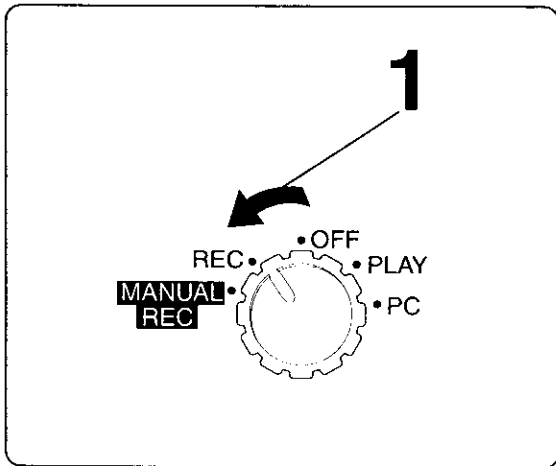

1 Open the Lens Cover. Set POWER Switch to REC.

- Turn the dial so that it clicks into position.
- The POWER LED lamp lights up.

2 Press MENU to display MENU screen.

```
<REC MENU 1/2>
AUDIO      ◀ ON ▶
SELFTIMER  OFF
BRIGHTNESS
OSD        ON
CLOCK SET
SEL : ▲▼  SET : ◀▶
EXIT : MENU
```

3 Press ▲ or ▼ to select the item.

```
<REC MENU 1/2>
AUDIO      ON
SELFTIMER  OFF
BRIGHTNESS
OSD        ◀ ON ▶
CLOCK SET
SEL : ▲▼  SET : ◀▶
EXIT : MENU
```

4 Press ◀ or ▶ to set it.

```
<REC MENU 1/2>
AUDIO      ON
SELFTIMER  OFF
BRIGHTNESS
OSD        ◀ OFF ▶
CLOCK SET
SEL : ▲▼  SET : ◀▶
EXIT : MENU
```

5 Press MENU to exit.

Operating the MENU Screen

When selecting MANUAL REC mode

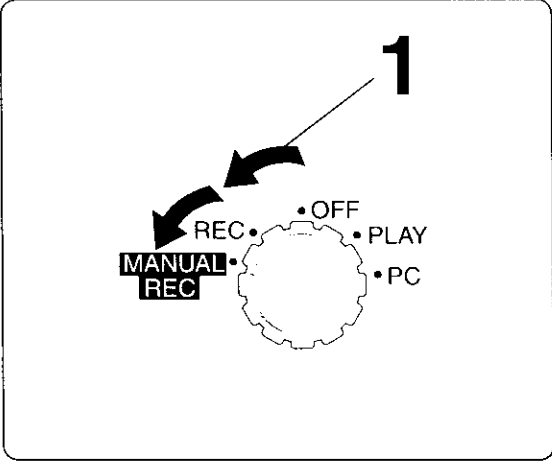

- 1 **Open the Lens Cover. Set POWER Switch to MANUAL REC.**
 - Turn the dial so that it clicks into position.
 - The POWER LED lamp lights up.

When selecting PLAY mode

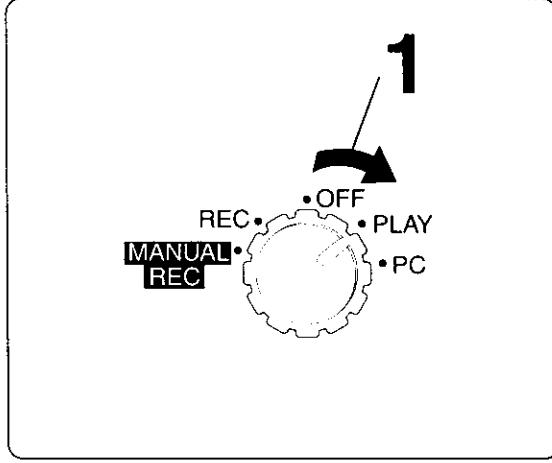

- 1 **Set POWER Switch to PLAY.**
 - Turn the dial so that it clicks into position.
 - The POWER LED lamp lights up.

Note

- While REC is sufficient for normal recording, select MANUAL REC when you want to make more precise settings.
- The REC, MANUAL REC, and PLAY menus consist of multiple pages. Press ▼ or ▲ repeatedly to scroll to the next or previous menu page.
- REC and PLAY functions cannot be operated while MENU screen is displayed.

- 2 Press MENU to display MENU screen.

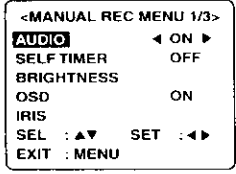

- 3 Press ▲ or ▼ to select the item.

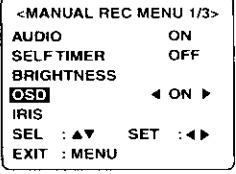

- 4 Press ◀ or ▶ to set it.

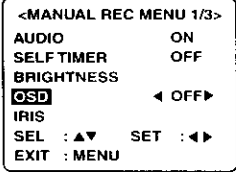

- 5 Press MENU to exit.

- 2 Press MENU to display the MENU screen.

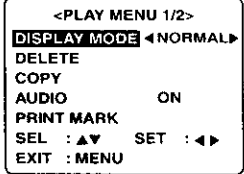

- 3 Press ▲ or ▼ to select the item.



- 4 Press ◀ or ▶ to set it.

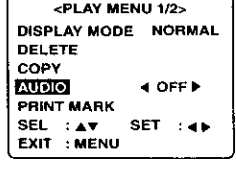

- 5 Press MENU to exit.

Setting the Clock

Before you begin

Open the Lens Cover. Set the POWER Switch to REC, MANUAL REC or PLAY. (See pages 19~20.) Press MENU to display the MENU screen.

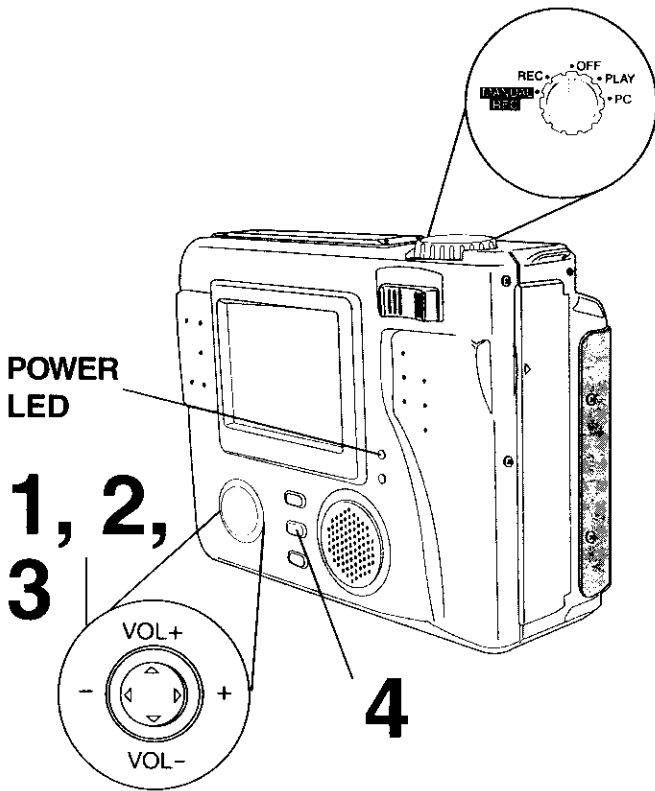

1 Press ▲ or ▼ to select CLOCK SET in the MENU screen.

<REC mode>

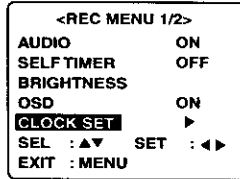

<MANUAL REC mode>

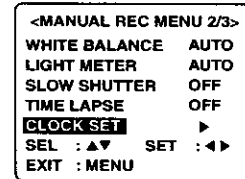

<PLAY mode>



2 Press ▶ to display CLOCK SET menu.

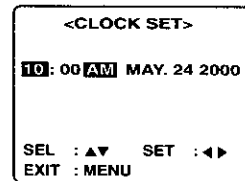

3 Press or hold down ▲ or ▼ to select hour, then press ▶ to set.

- Repeat for minute, month, day and year.
- Double check all items before exiting the menu.

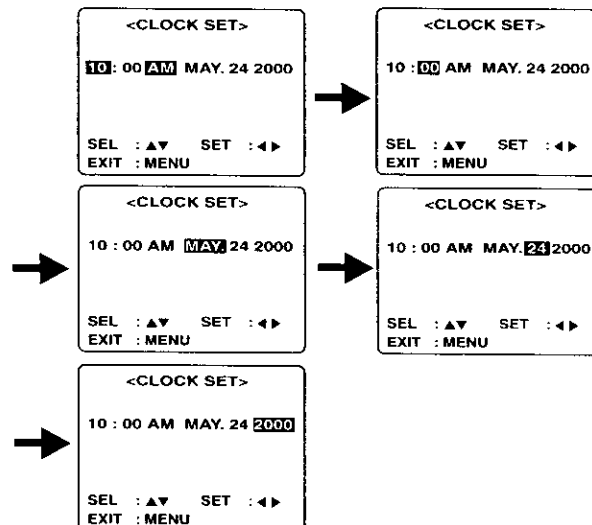

4 Press MENU twice to exit. Clock starts when menu is exited.

Note

- To make corrections, repeat steps 1~3.
- The clock will continue to operate about 8 hours after the battery has been removed. If you need to set clock again, repeat steps above.

Capturing Images

Super Fine Mode, Fine Mode, Normal Mode, Zoom Mode

—Before you begin—
Open the Lens Cover. Set the POWER Switch to REC or MANUAL REC.
 (See pages 19~20.)

3, 4

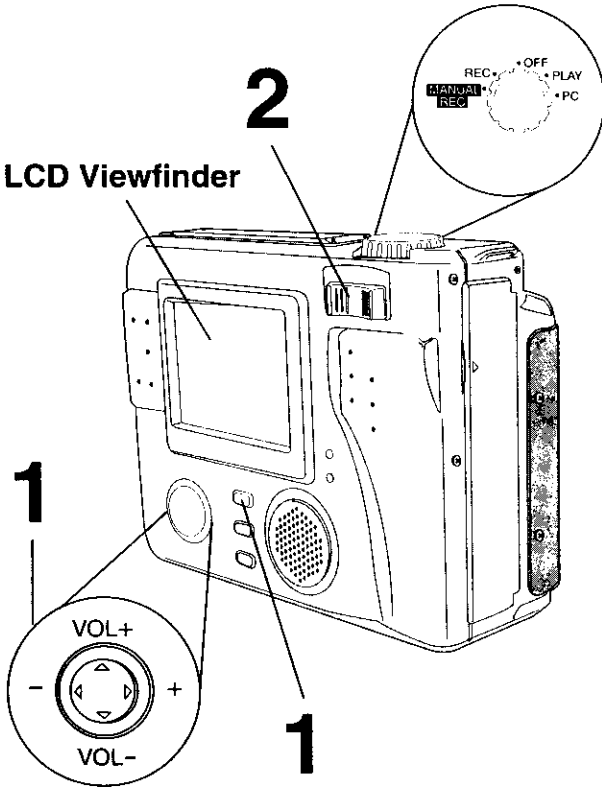
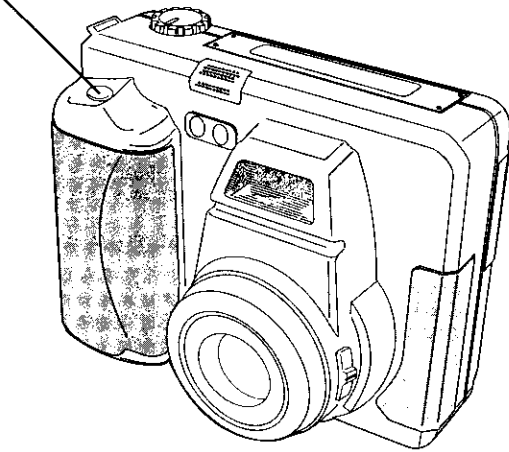

22

- 1 Press REC MODE** repeatedly to select recording mode (SF, F, N, ZOOM). (See page 26.)
 - If you want to use SLOW SHUTTER: In Manual mode, press MENU to display the MENU screen, and then press ▲ or ▼ to select SLOW SHUTTER. Press ◀ or ▶ to select ON. (See page 11.)

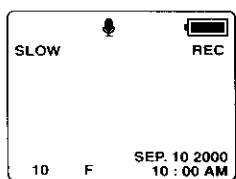
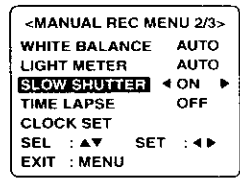

- 2 Press ZOOM T or W** to zoom In and Out.
 - Zoom magnification level is up to x3.
 - There is no zoom indication on the LCD Viewfinder.
- 3 Press SHTR** down halfway to lock Auto Focus.
 - Beep sounds twice. (See page 27.)
- 4 Press SHTR** down the rest of the way to actually capture the image.
 - Shutter sounds once. (See page 27.)
 - While the Digital Camera processes the image, REC will blink on the LCD Viewfinder and the captured image will be displayed on the LCD Viewfinder for a few seconds.

Note

- While the captured image is displayed on the LCD Viewfinder you cannot capture another image. Until that image is no longer displayed on the screen.
- The power automatically shuts off to conserve power if there is no activity for over one minute while the battery is used as a power source. Press SHTR to return POWER on.
- Do not subject unit to a strong impact during record or playback. Unit may not function normally.
- Do not use in extreme heat (104 °F and above). This may damage the disk. Also, in extremely hot places (104 °F and above), remove the disk from the camera and store to avoid damaging disk.

For assistance, call 1-800-272-7033.

Capturing Images

Capturing images (AUDIO ON)

You can record audio with a still image. The still image and audio can then be played back in the PLAY mode. (See page 20.) Please follow the instructions below.

Before you begin

Open the Lens Cover. Set the POWER Switch to REC or MANUAL REC. (See pages 19~20.)

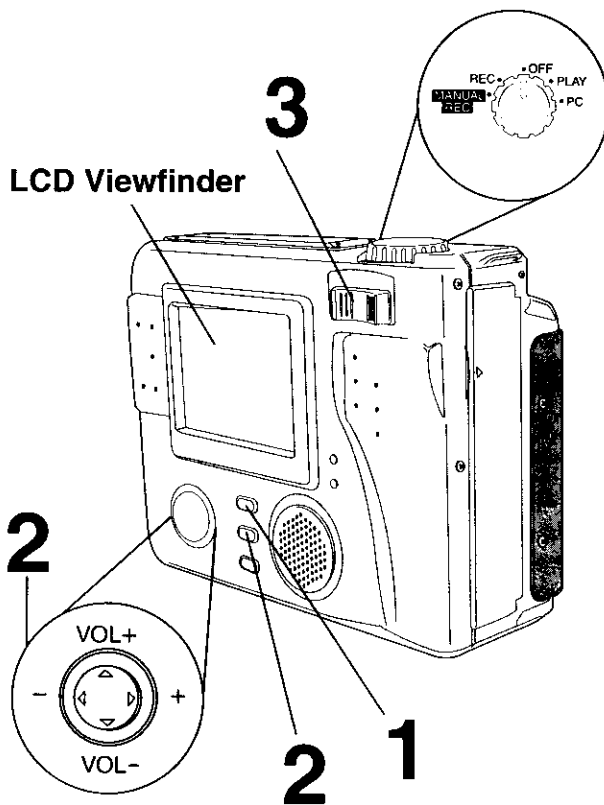

1 Press **REC MODE** repeatedly to select recording mode (SF, F, N, ZOOM). (See page 26.)

2 Press **MENU** to select AUDIO and then press **◀** or **▶** to select AUDIO ON.

<REC mode>

<REC MENU 1/2>	
AUDIO	◀ ON ▶
SELF TIMER	OFF
BRIGHTNESS	
OSD	ON
CLOCK SET	
SEL : ▲▼	SET : ◀▶
EXIT : MENU	

<MANUAL REC mode>

<MANUAL REC MENU 1/3>	
AUDIO	◀ ON ▶
SELF TIMER	OFF
BRIGHTNESS	
OSD	ON
IRIS	
SEL : ▲▼	SET : ◀▶
EXIT : MENU	

- Press **MENU** to exit.
- When AUDIO is ON, The  is displayed on the screen.

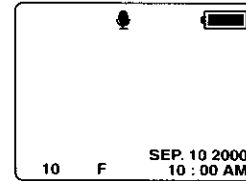

- If you want to use SLOW SHUTTER: Press **MENU** to display the MENU screen, and then press **▶** or **▼** to select SLOW SHUTTER. Press **◀** or **▶** to select ON (MANUAL REC only). (See page 11.)

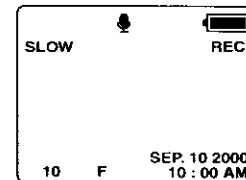

3 Press **ZOOM T** or **W** to zoom In and Out.

- Zoom magnification level is up to x3.
- There is no zoom indication on the LCD Viewfinder.

(Continued on next page)

Capturing Images

4, 5

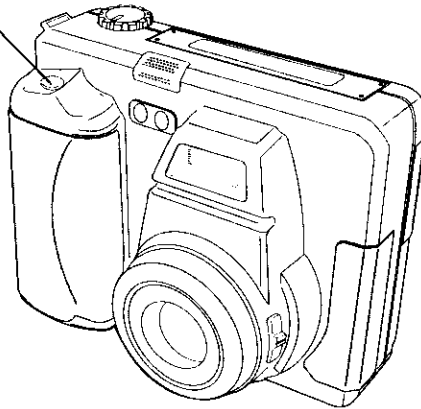

- 4** Press **SHTR** down halfway to lock Auto Focus.
- Beep sounds twice. (see page 27.)

- 5** Press **SHTR** down the rest of the way to actually capture the image.
- Shutter sounds once. (See page 27.)
 - You can record the audio for 5 seconds by pressing the **SHTR** button.

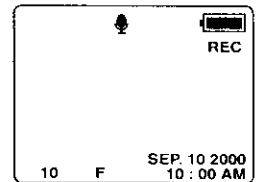



- While the Digital Camera processes the image, **REC** OSD will appear on the LCD. The captured image will be displayed on the LCD Viewfinder for a few seconds.

Note

- When a captured image is displayed on the LCD Viewfinder, you will not be able to capture another image until that image is no longer displayed on the screen.
- The power automatically shuts off to conserve power if there is no activity for over one minute while the battery is used as a power source. Press **SHTR** to return **POWER** on.
- Do not subject unit to a strong impact during record or playback. Unit may not function normally.
- Do not use in extreme heat (104 °F and above). This may damage the disk. Also, in extremely hot places (104 °F and above), remove the disk from the camera and store to avoid damaging disk.

Capturing Images

Motion Image Rec Mode Burst Rec Mode



You can capture a motion image by selecting  in REC MODE. And you can capture a burst image by selecting  in REC MODE.

Before you begin

Open the Lens Cover. Set the POWER to REC or MANUAL REC. (See pages 19~20.)

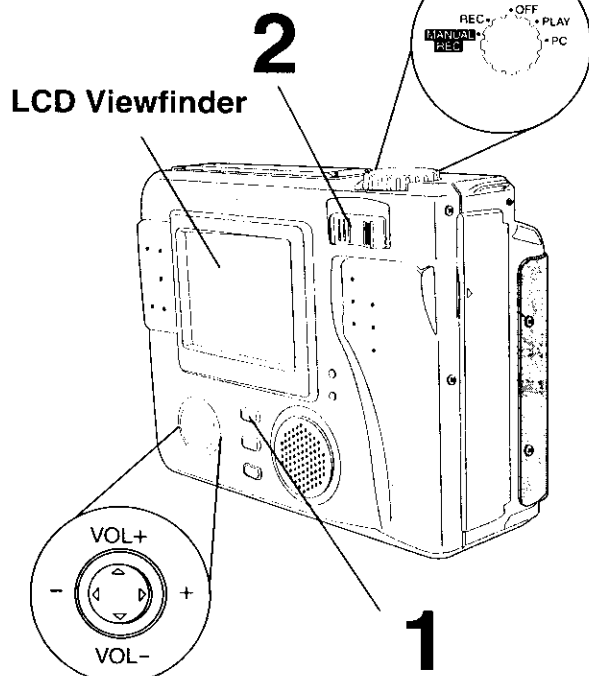
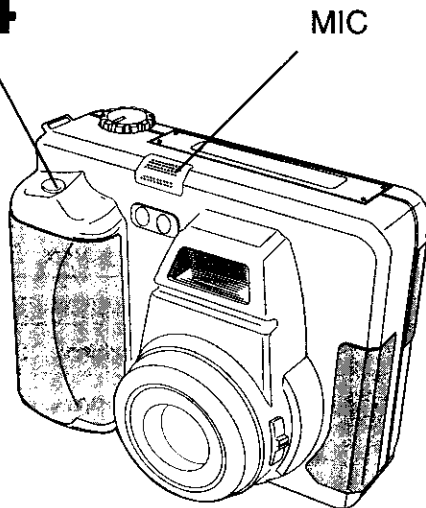
3, 4



- 1 Press **REC MODE** repeatedly to select Motion () or Burst () recording mode.
- 2 Press **ZOOM T** or **W** to zoom In and Out.
 - Zoom magnification level is up to x3.
 - There is no zoom indication on the LCD Viewfinder.
- 3 Press **SHTR** down halfway to lock Auto Focus.
 - Beep sounds twice. (See page 27.)
- 4 Hold down the **SHTR** button the rest of the way to actually capture the image. If you select **AUDIO ON**, audio will be recorded through the MIC.

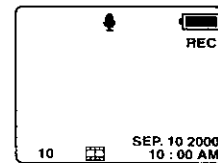

REC MODE

- A Motion Image  can be captured up to 10 seconds while SHTR is pressed with audio.

REC MODE

- A Burst Image  can be captured every 0.5 seconds/frame up to 16 frames while SHTR pressed.
- While the Digital Camera processes the image, REC will blink on the LCD Viewfinder and the captured image will be displayed on the LCD Viewfinder for a few seconds.
- Cannot record audio.

Note

- If you select , you can not record audio.
- When a captured image is displayed on the LCD Viewfinder, you will not be able to capture another image until that image is no longer displayed on the screen.
- The power automatically shuts off to conserve power if there is no activity for over one minute while the battery is used as a power source. Press SHTR to return POWER on.

Capturing Images

Recording Mode

Recording Mode



- SF : Super Fine Mode (with audio)**
Select this mode when you want the highest quality resolution with the lowest compression (i.e. for printing).
- F : Fine Mode (with audio)**
Select this mode when you want a high resolution (i.e. for printing or for archiving an image).
- N : Normal Mode (with audio)**
Select this mode when you want a lower resolution image (i.e. for e-mailing or posting on the Internet).
- ZOOM : Zoom Mode (with audio)**
Using ZOOM mode magnifies the image to twice its normal size.
-  **: Motion Image Rec Mode (with audio)**
Capture an image every 0.1 seconds/frame for up to 10 seconds while the SHTR button is pressed. This creates a mini movie.
• REC will blink on the LCD Viewfinder while processing a motion image.
-  **: Burst Rec Mode**
Capture image every 0.5 seconds/frame up to 16 frames while shutter button is pressed.
• If the number of remaining pages is less than 16, only the number of images equal to the remaining memory will be captured.

Image Resolution and Capacity (SuperDisk Diskette)





REC Mode	Image Resolution	Capacity (w/supplied Super Disk)
SF	1,280 × 960	Approx. 450 images
F	1,280 × 960	Approx. 900 images
N	640 × 480	Approx. 1500 images
ZOOM	640 × 480	Approx. 1500 images
	320 × 240	10 sec. × Approx. 90 sets
	640 × 480	Approx. 1500 images

Image Resolution and Capacity (Floppy Disk)

REC Mode	Image Resolution	Capacity (w/Floppy Disk)
SF	1,280 × 960	Approx. 5 images
F	1,280 × 960	Approx. 10 images
N	640 × 480	Approx. 17 images
ZOOM	640 × 480	Approx. 17 images
	320 × 240	10 sec. × Approx. 1 set
	640 × 480	Approx. 17 images

- The number of images given for each mode applies when all images are taken in same mode.
- You can change recording modes at any time before capturing an image.
- The number of images that can be captured may differ depending on the subject. After capturing an image, the number may not decrease, or it may decrease by two. This is normal.

Capturing Images

Beep

Set Digital Camera to beep (low or high volume), when an image is captured, or set to OFF.

Before you begin

Set the **POWER Switch** to **REC**, **MANUAL REC** or **PLAY**. (See pages 19~20.) Press **MENU** to display the **MENU** screen.

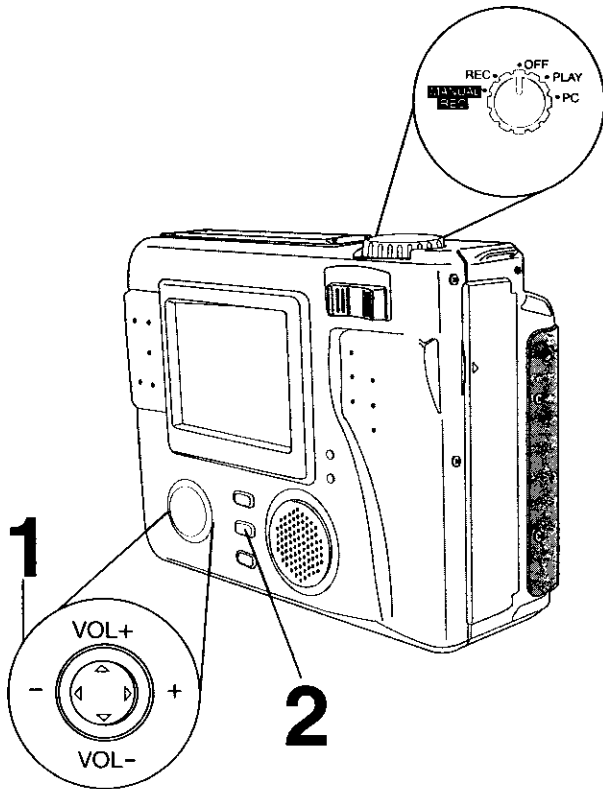

Note

- You can select BEEP mode in the REC, MANUAL REC and PLAY mode.
- If you change the setting, repeat step 2.

- 1 Press **▲** or **▼** to select BEEP and Press **◀** or **▶** to select one of the three settings shown below.

<REC mode>

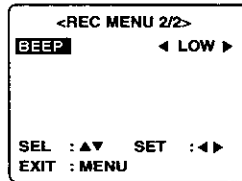

<MANUAL REC mode>

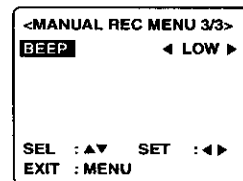

<PLAY mode>

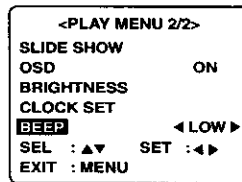

- OFF** : Select to turn OFF the beep sound.
LOW : Select to hear a low beep sound.
HIGH : Select to hear a loud beep sound.

- 2 Press **MENU** to exit.

Digital Camera will beep:

- Once when the BEEP is set to LOW or HIGH in the MENU mode as follows.
When you press the REC MODE, MENU or FLASH buttons.
When you press the **▲**, **▼**, **◀**, or **▶** buttons while adjusting Brightness, Iris and Volume.
When you press the **◀** or **▶** button while adjusting Brightness, Iris and volume.
- Twice when you press the shutter button half way to adjust the focus.

Adjusting LCD Viewfinder Brightness

You may want to brighten or darken the LCD (Liquid Crystal Display) Viewfinder for easier viewing. This adjustment will not affect the captured image brightness.

Before you begin

Set POWER Switch to REC, MANUAL REC, or PLAY. (See pages 19~20.)

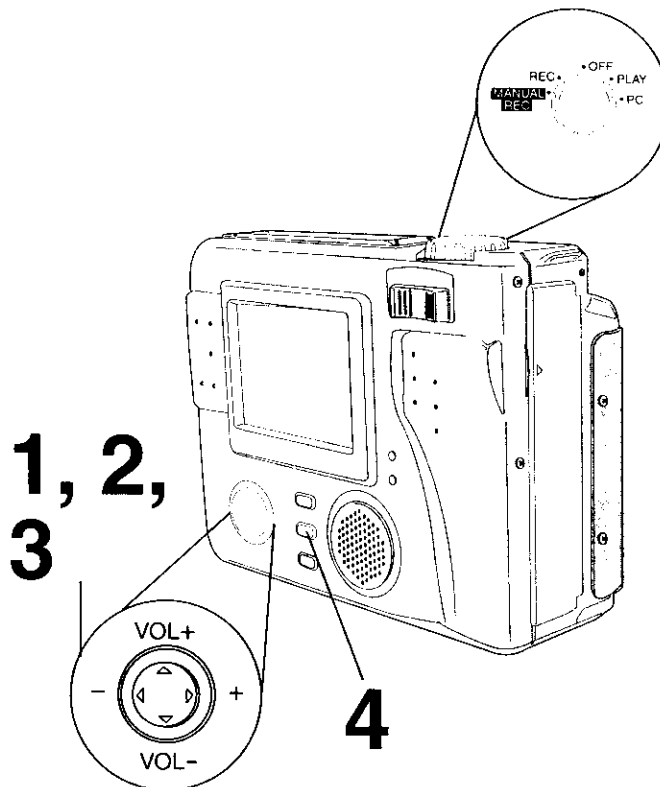

Note

- The brightness level set in this menu is not related to the brightness of the captured image.

- Press **▲** or **▼** to select BRIGHTNESS in the MENU screen.

<REC mode>

<REC MENU 1/2>	
AUDIO	ON
SELF TIMER	OFF
BRIGHTNESS	▶
OSD	ON
CLOCK SET	
SEL : ▲▼	SET : ◀▶
EXIT : MENU	

<MANUAL REC mode>

<MANUAL REC MENU 1/3>	
AUDIO	ON
SELF TIMER	OFF
BRIGHTNESS	▶
OSD	ON
IRIS	
SEL : ▲▼	SET : ◀▶
EXIT : MENU	

<PLAY mode>

<PLAY MENU 2/2>	
SLIDE SHOW	
OSD	ON
BRIGHTNESS	▶
CLOCK SET	
BEEP	LOW
SEL : ▲▼	SET : ◀▶
EXIT : MENU	

- Press **▶** to display LCD BRIGHTNESS screen.

<LCD BRIGHTNESS>	
-	□□□■□□□+
SET : ◀▶	
EXIT : MENU	

- Press **◀** (-) or **▶** (+) to change the brightness of the LCD Viewfinder; (+) for brighter, (-) for darker.

- Press **MENU** twice to exit.

Note

- The original BRIGHTNESS will be restored when the Digital Camera is turned off.

Playing Back Captured Images

Manual Playback

You can playback recorded images on the LCD Viewfinder.

Before you begin

Set the POWER Switch to PLAY. (See pages 19~20.)

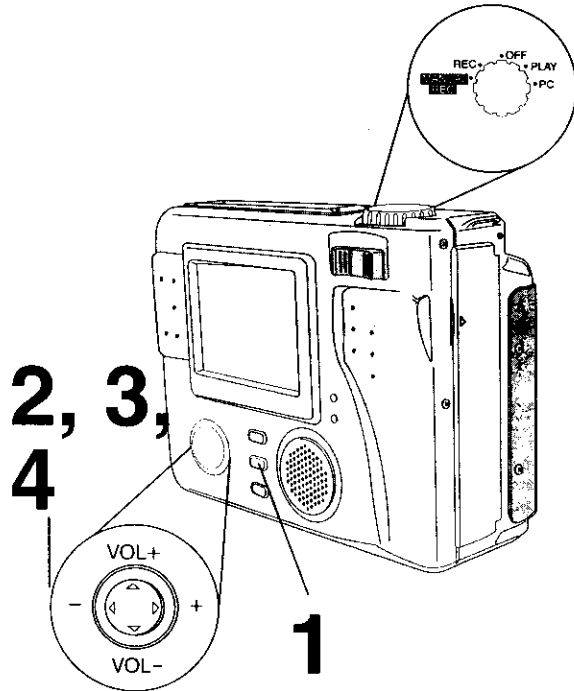

Note

- When selecting AUDIO ON, a still image with audio will be played. The volume of audio can be adjusted by pressing VOL +/-.

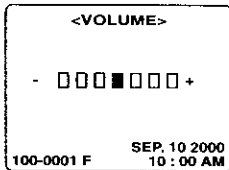

- Do not subject unit to a strong impact during record or playback. Unit may not function normally.
- Do not use in extreme heat (104 °F and above). This may damage the disk. Also, in extremely hot places (104 °F and above), remove the disk from the camera and store to avoid damaging disk.
- The power automatically shuts off to conserve power if there is no activity for over two minutes while the battery is used as a power source. Press SHTR to return POWER on.

- 1 Press MENU to display PLAY MENU and press ► to set DISPLAY MODE to NORMAL.

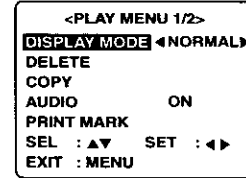

- 2 Press ▲ or ▼ to select AUDIO, and press ◀ or ▶ to select AUDIO ON or OFF. Press MENU to exit.

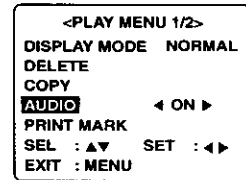

- 3 Press ► (+) or ◀ (-) repeatedly, [► (+) for ascending order, and ◀ (-) for descending order] to change the displayed image on the LCD Viewfinder.

- The image page number and recording mode are displayed at the bottom of the screen.

<AUDIO ON>

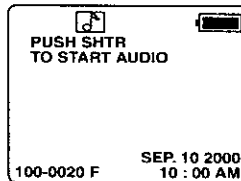

<AUDIO OFF>

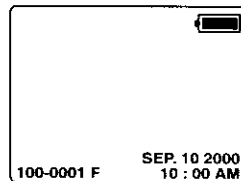

- If there are no images in memory, a blue back screen will be displayed.

- 4 Hold down ► (+) or ◀ (-), [► (+) for ascending order, and ◀ (-) for descending order] to quickly advance the images on the LCD Viewfinder.

- Page number is changed continuously while ► (+) or ◀ (-) is held down.
- Selected page is displayed when button is released.

Basic Operation

Playing Back Captured Images

Motion Image Playback

When a captured image in  (Motion Image Rec) mode is displayed. (See page 25.)

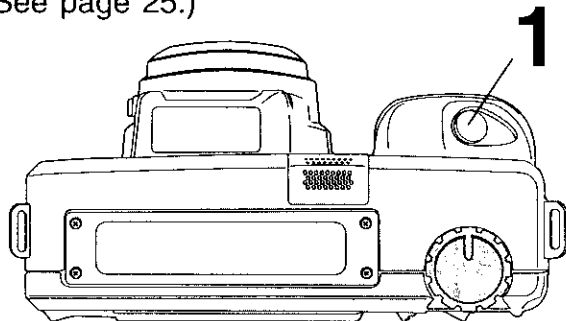

The following message will appear.

- Adjust the volume by pressing VOL +/-.

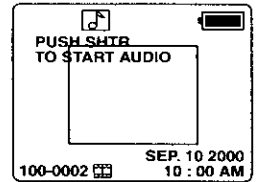

- 1 Press **SHTR** to start playback of Motion image.

Multi Playback

If you select  in the PLAY MENU, you will be able to see Thumbnail images on the LCD Viewfinder (each Thumbnail page will contain 9 images).

Before you begin
Set the **POWER Switch** to **PLAY**. (See pages 19~20.)

- 1 Press **▲** or **▼** to select **DISPLAY MODE** in the MENU screen. And, press **◀** or **▶** to select .

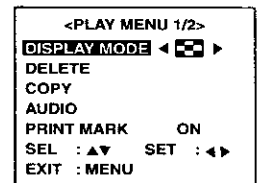

- 2 Press **MENU**. A Multi Image Playback screen will appear.

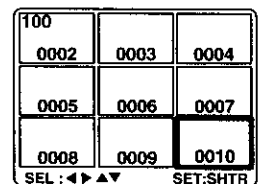

- When many images are stored in the Disk Media, it may take a while for the Multi Image screen to playback.

- 3 Press **▶ (+)** repeatedly to scroll forward through Multi Image pages (each page contains 9 images).
 - All images will be displayed as still images.

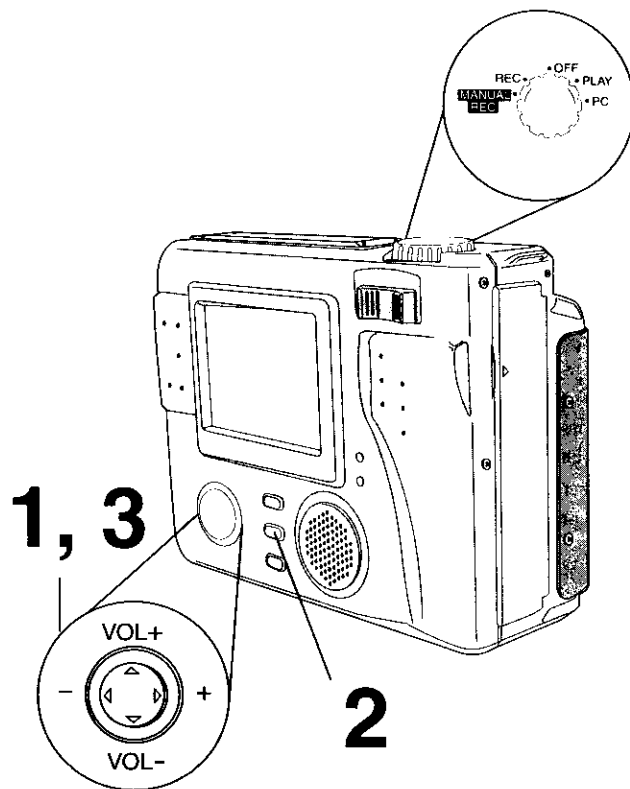
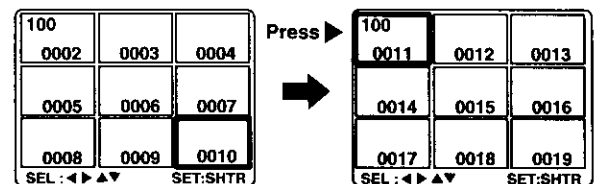

Playing Back Captured Images

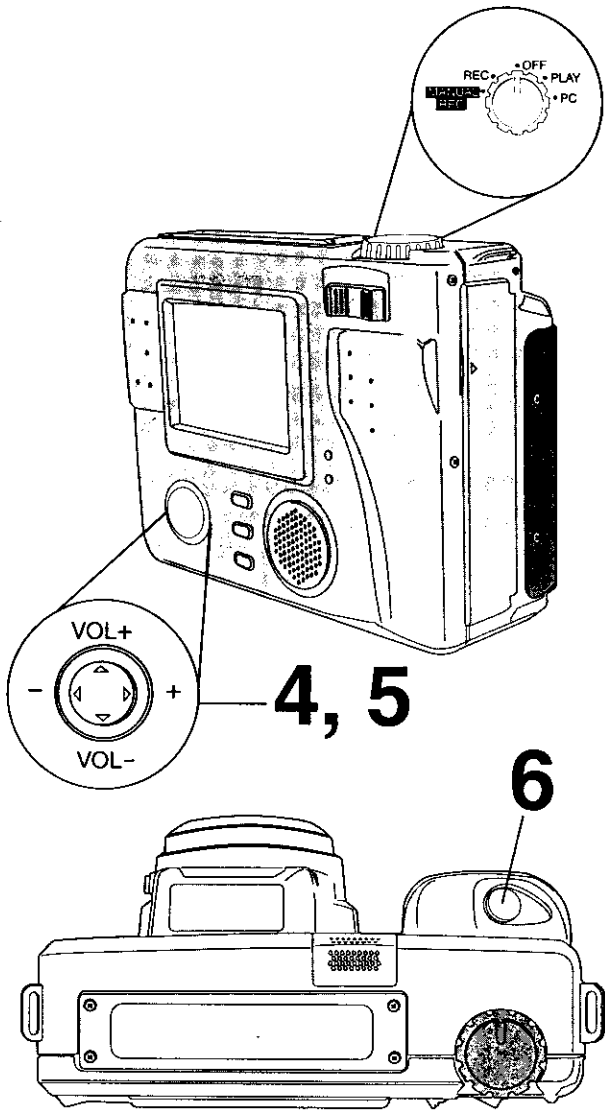

4 Press ◀ (-) to move back through the images on the page until the number of the image you want to select is highlighted.

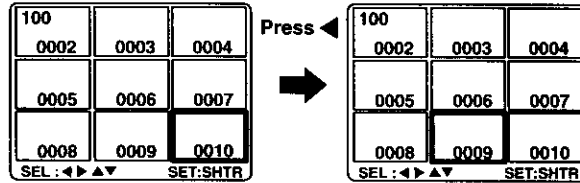

5 Press ▲ or ▼ to go directly to the next or previous page of images.

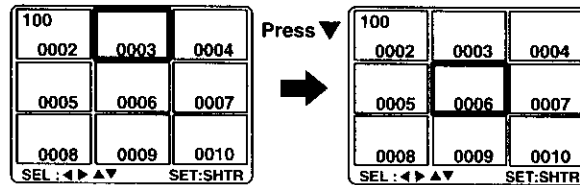
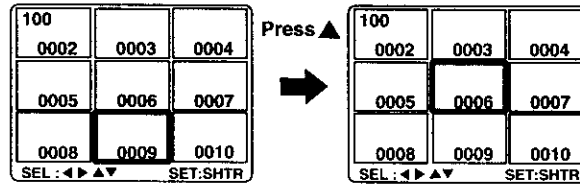

6 Press SHTR to playback the selected image, and to return to Manual Playback.

Basic Operation

Playing Back Captured Images

Zoom Playback

Before you begin
Set the **POWER** Switch to **PLAY**. (See pages 19~20.)

1 Press **MENU** to display **PLAY MENU** and press **▶** to set display mode to **ZOOM**.

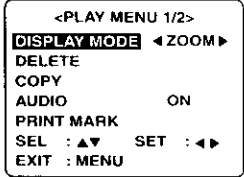

2 Press **MENU** to zoom(x2) in on the center portion of the image.

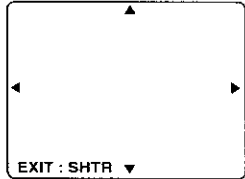

3 Press **▶**, **◀**, **▲**, or **▼** repeatedly to change the zooming area.

4 Press **SHTR** to restore the image to its normal size.

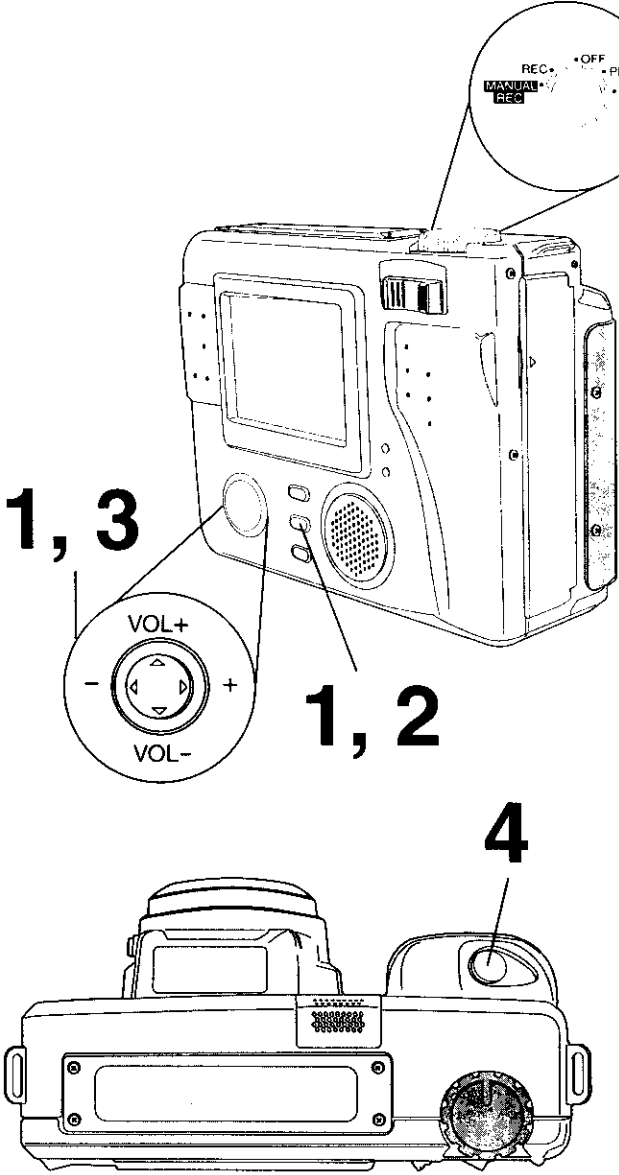

Viewing Images on a TV Screen and Transferring Images to a VCR

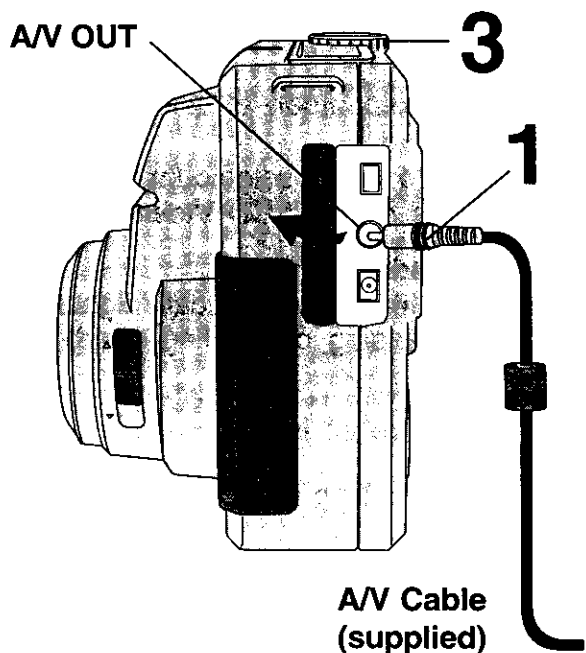

- 1** Connect the Digital Camera to your TV or VCR using the A/V Cable (supplied) as shown.
- 2** Turn on your TV and select its video input mode. Then, select its line input mode. (Refer to your TV manual.)
- 3** Set the Digital Camera POWER to PLAY. You may select playback as described on page 29 to page 32.
 - The POWER LED lamp lights up.
- 4** Start a recording of the desired images. (Refer to your VCR manual.)

Note

- For extended periods of use, it is recommended to use the AC Adaptor (supplied) as a power source.

Basic Operation

TV Monitor

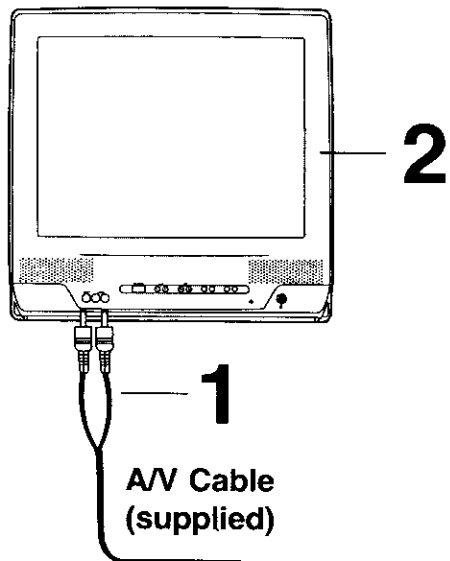

VCR Monitor

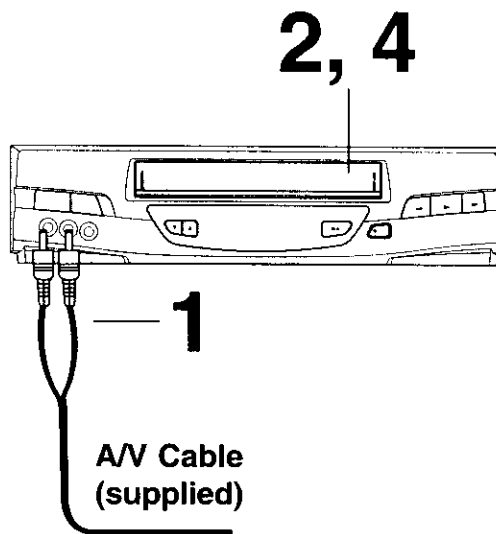

Connect the A/V OUT Terminal on the Camera and the AUDIO IN/VIDEO IN on the VCR or TV using the A/V Cable (supplied).

Using the Built-in Flash

This camera features a Built-in Flash which can be used to capture images in dimly lit conditions.

—Before you begin—

Set the **POWER Switch** to **REC** or **MANUAL REC.** (See pages 19~20.)

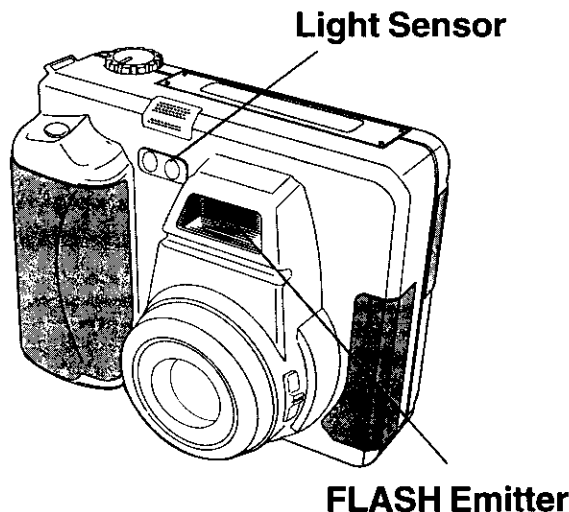
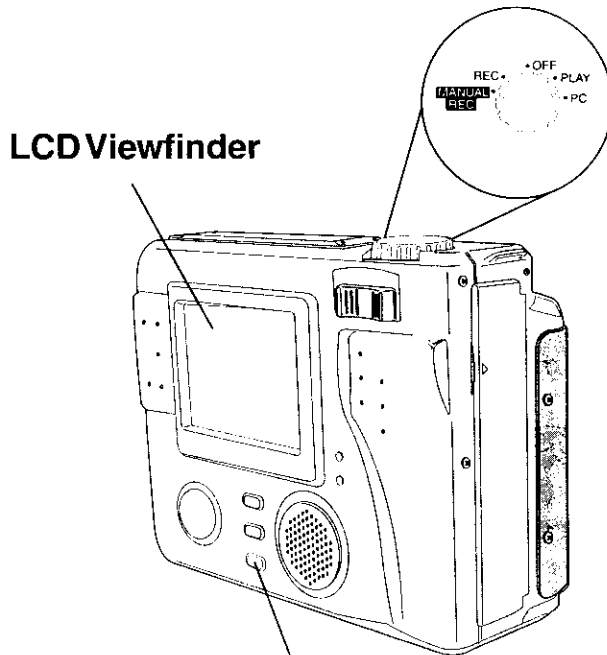



1 Press  repeatedly to select flash mode.
The mode that is selected will be displayed on the LCD Viewfinder.

AUTO (No indication) :



The flash automatically lights depending on lighting conditions.

 : The flash will light whenever you capture an image.

 : This setting reduces the red reflections in the eye when the flash lights. The flash will light twice, once before capturing and then once during capturing. (The flash will light whenever you capture an image.)

 : The flash will not light even when you capture an image. (MANUAL REC mode only.)

Note

- The effective range of the flash is roughly 7.8 inches (20 cm) to 9.8 feet (3 m). If you are using the flash in very bright areas, the image background may become dark.
- Do not use the flash close to a person's face as it may be harmful to the eyes. Especially when capturing images of infants or small children, keep at least 3.3 feet (1 m) away.
- When the recording mode is set to  (Motion Image Rec) or  (Burst Rec), the flash mode will go to  (OFF).
- Do not cover the FLASH Emitter and Light Sensor with your finger or other object.

White Balance

Auto White Balance automatically maintains optimum color balance in most lighting conditions.

Before you begin

Set the **POWER Switch to MANUAL REC.** (See pages 19~20.)

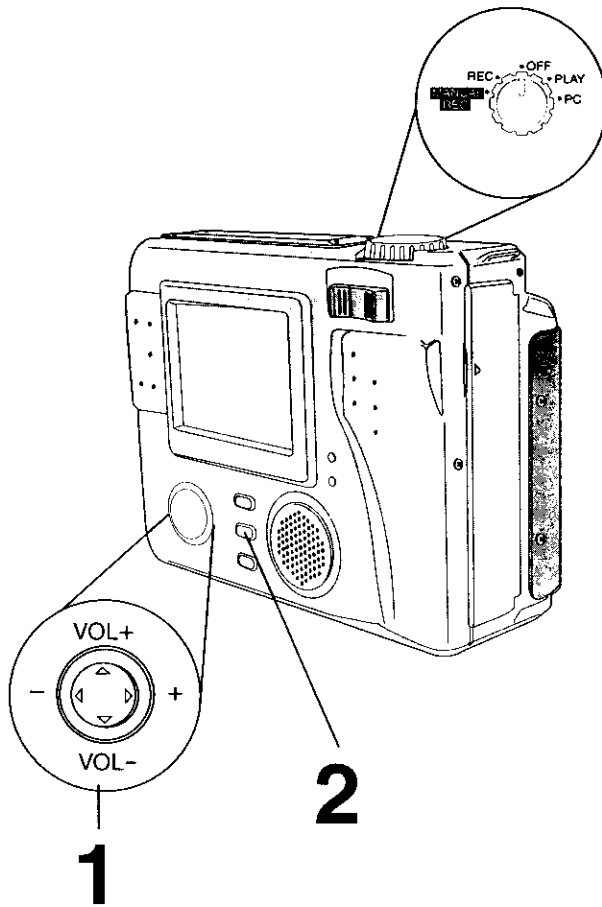

- 1 Press **▲** or **▼** to select **WHITE BALANCE** and press **◀** or **▶** to select one of the four settings shown below.
 - Default setting is **AUTO**.

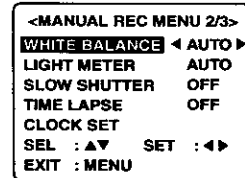

AUTO (No indication) :

Automatically maintains optimum color balance in most lighting conditions.



: When the source illumination is a halogen lamp.



: When shooting outdoors on a sunny day.

WS (SET) : Manually set the color Balance. To set the color balance to a fixed position based on the current lighting level, press the **SHTR** button while shooting a white object.

This setting will be maintained until the **MENU** button is pressed to exit. The color balance will then return to the **AUTO** setting.

Special Features

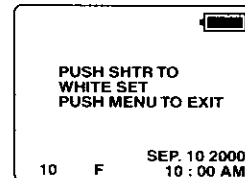

- 2 Press **MENU** to exit.

- Selected mode will appear on the LCD Viewfinder. (See page 10.)

Note

- When the Camera is set to **POWER OFF**, the white balance setting will be stored in Camera memory. When the Camera is set to **POWER ON**, the white balance setting will default to the previous setting.

Light Metering

According to the recording condition and purpose, set light metering to measure exposure time.

Before you begin

Set the **POWER Switch** to **MANUAL REC.** (See pages 19~20.)

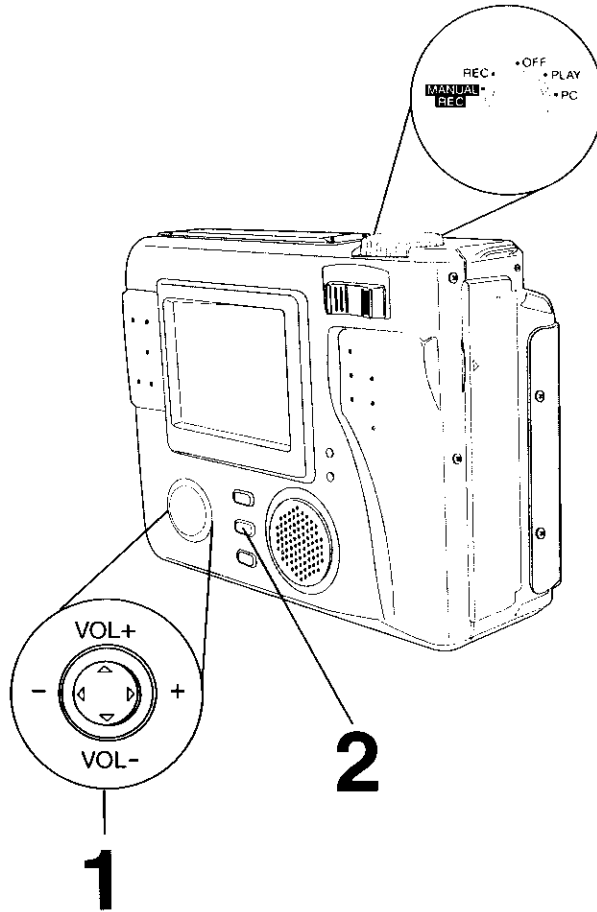

- 1 Press **▲** or **▼** to select **LIGHT METER** and press **◀** or **▶** to select one of the two settings shown below.
 - Default setting is **AUTO**.

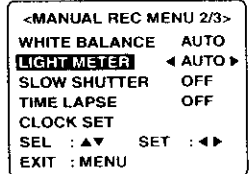

AUTO (No indication) :

Ideal for normal capturing, the focus is set to the center portion of the finder and the entire image is metered.

- ◻ : A small sphere in the center portion of the finder is metered. This mode is useful for capturing back lit conditions, such as when the subject is brightly lit.

2 Press **MENU** to exit.

- Selected mode will appear on the LCD Viewfinder. (See page 11.)

Self Timer Recording

The Self-Timer allows you to capture an image about 10 seconds after pressing the shutter.

Before you begin

Set the **POWER** Switch to **REC** or **MANUAL REC.** (See pages 19~20.)

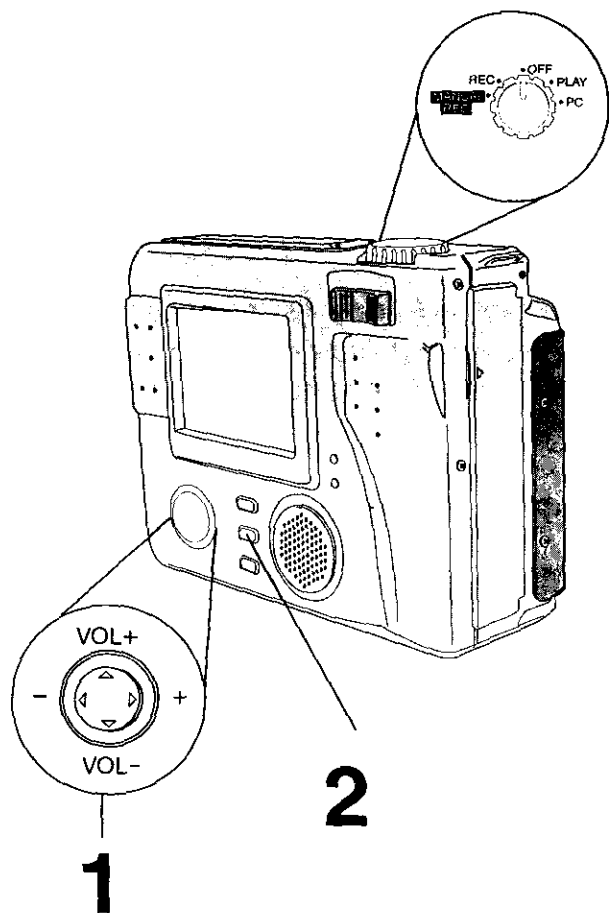

- 1 Press **▲** or **▼** to select **SELF TIMER** and press **◀** or **▶** to select **ON**. This puts the camera in self-timer mode.

<REC Mode> **<MANUAL REC Mode>**

```

<REC MENU 1/2>
AUDIO          ON
SELF TIMER    ◀ ON ▶
BRIGHTNESS
OSD           ON
CLOCK SET
SEL : ▲▼     SET : ◀▶
EXIT : MENU
    
```

```

<MANUAL REC MENU 1/3>
AUDIO          ON
SELF TIMER    ◀ ON ▶
BRIGHTNESS
OSD           ON
IRIS
SEL : ▲▼     SET : ◀▶
EXIT : MENU
    
```

- After **ON** is selected and **MENU** is pressed,  mark will appear on the LCD Viewfinder (see page 10).

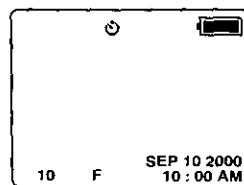

- 2 Press **MENU** to exit.

- 3 Press **SHTR.**

- The Self-Timer Indicator lights up. The indicator starts flashing rapidly after about 8 seconds and the image is captured about 2 seconds later.
- The Self-Timer setting returns to **OFF** mode each time an image is captured. Repeat these steps each time Self-Timer is used.

Self-Timer Indicator

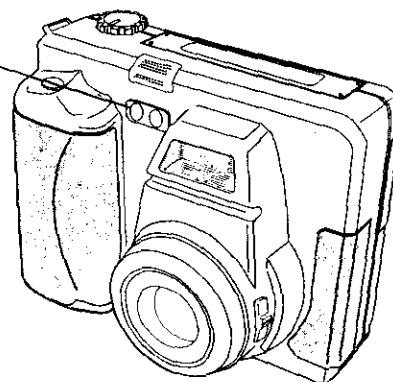
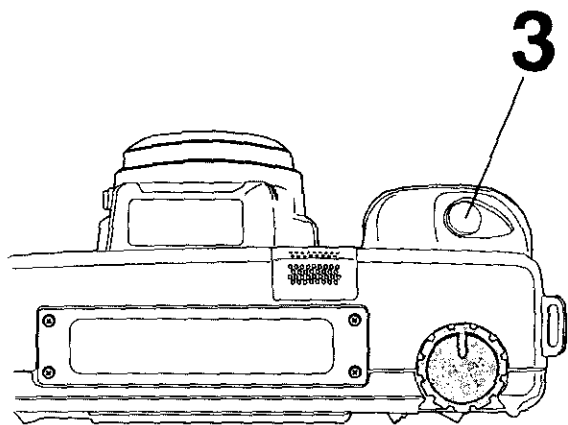

Special Features

Adjusting the Iris Manually

Normally, the camera adjusts the exposure automatically. However, when the background is extremely bright, or when the subject is backlit, you can compensate by adjusting the Iris manually.

Before you begin

Set the **POWER** to **MANUAL REC.** (See pages 19~20.)

1 Press **▲** or **▼** to select IRIS.

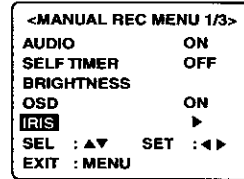

2 Press **▶** to display IRIS screen.

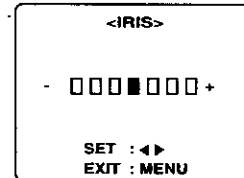

3 Press **◀ (-)** or **▶ (+)** to change the IRIS; Press (+) to increase the brightness, Press (-) to decrease the brightness.

4 Press **MENU** twice to exit.

Note

- There are 7 brightness compensation levels ranging from -3 to +3.
- A blue sky may appear somewhat whiter when the brightness is increased.
- The brightness cannot be adequately compensated for in extreme backlight conditions.
- The original exposure is automatically restored when the power is turned off.

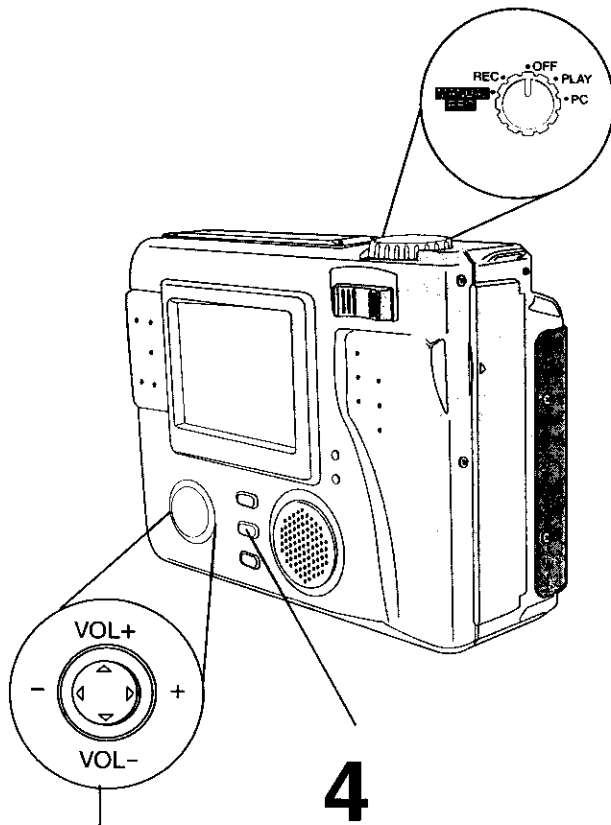

1, 2, 3

4

Time Lapse Recording

Time Lapse enables you to set the camera to automatically capture an image from once every minute to once every 24 hours.

Before you begin
Set the **POWER Switch** to **MANUAL REC.** (See pages 19~20.)

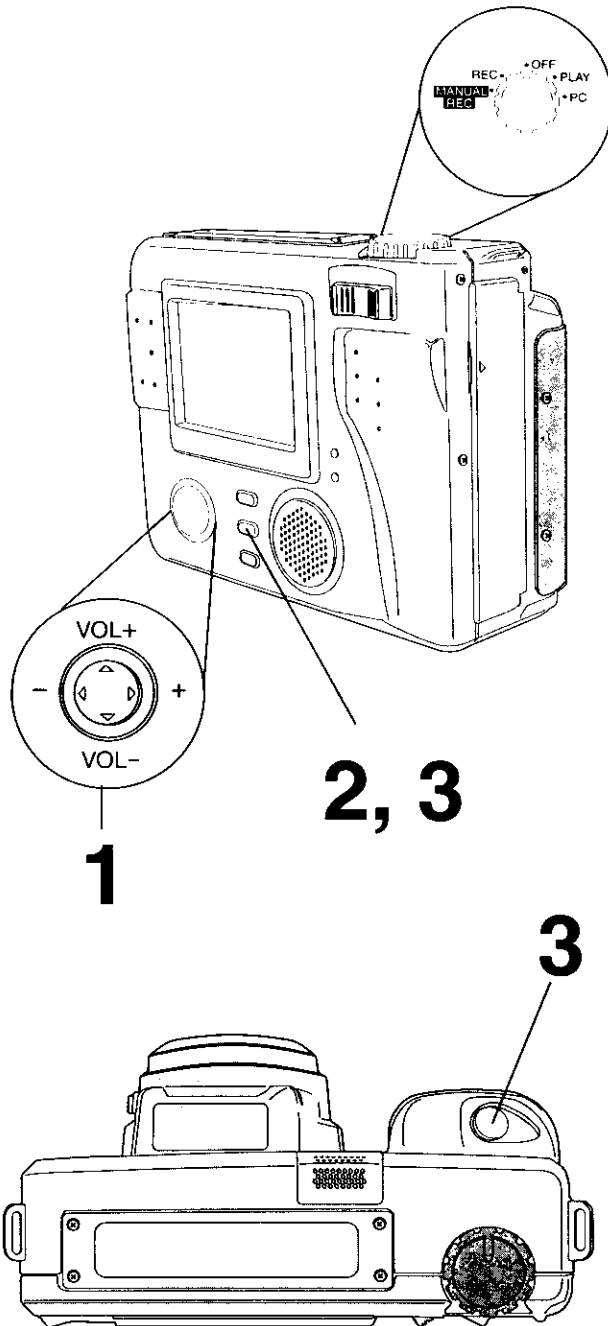

1 Press **▲** or **▼** to select **TIME LAPSE** and press **▶** to select time interval. You can select a capture rate of approx. 1MIN, 5MIN, 10MIN, 30MIN, 1HOUR, 6HOUR, 12HOUR, or 24HOUR.

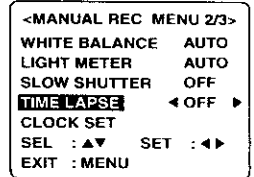

- Time Lapse feature is available with Super Fine (SF), Fine (F), Normal (N) and Zoom mode.
- If the REC mode is set to or , please change REC mode. (See page 26.)

2 Press **MENU** to set time lapse mode.

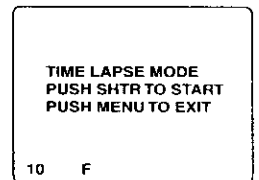

3 Press **SHTR** to start time lapse mode recording.

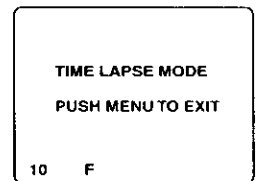

- REC will blink on the LCD Viewfinder while image is being processed.
- Press **MENU** to exit this mode.

Note

- During time lapse recording (even during non-recording intervals), the battery may become depleted. Therefore, using an AC Adaptor (supplied) is recommended.

To Delete Specific Images

You can delete unwanted images and increase the remaining image memory.

Warning: Once deleted, images cannot be restored.

Before you begin

Set the **POWER Switch** to **PLAY**. (See pages 19~20.)

- 1 Press **▲** or **▼** to select **DELETE** and press **▶** to display **DELETE** menu.

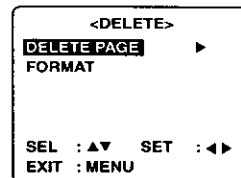
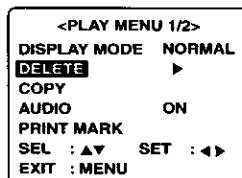

- 2 Press **▶** to display **DELETE PAGE** menu.

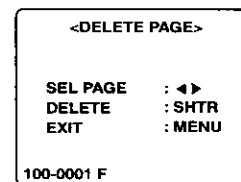

- 3 Press **◀** or **▶** to select the image page to be deleted.

- 4 Press **SHTR** to delete a image.
 - To delete other specific image pages, please repeat steps 3~4.
 - Press **MENU** twice to exit.

Note

- To delete all image data, refer to "Formatting the Disk Media" on page 41.

Important:

- While deleting image, **do not turn off the Digital Camera or unplug the AC Adaptor** (supplied) because this will cause irreversible damage to the memory, resulting in reduced image storage capacity.

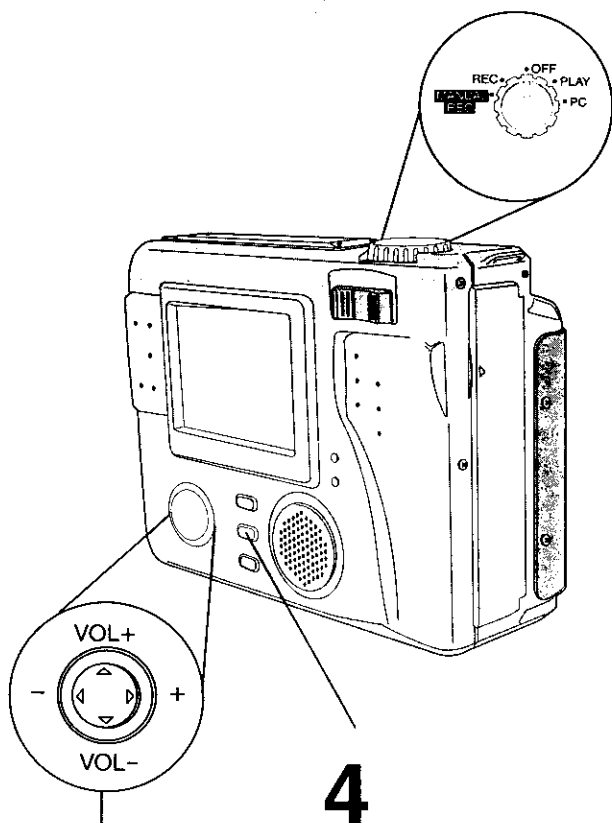

1, 2, 3

4

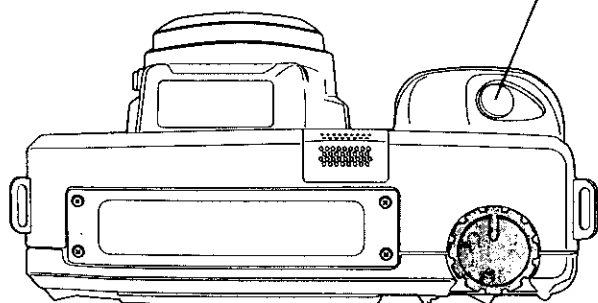

Formatting the Disk Media

You can easily format your Disk Media using this operation. Formatting of the Disk Media is done in the quick format.

Warning: Formatting permanently removes all image data as well as any other files on the Disk.

Before you begin

Set the **POWER** Switch to **PLAY**. (See pages 19~20.)

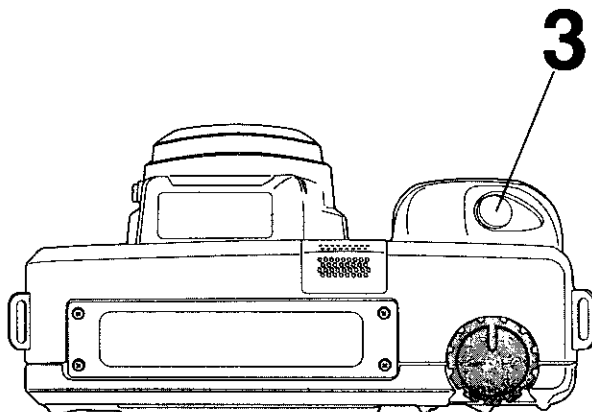
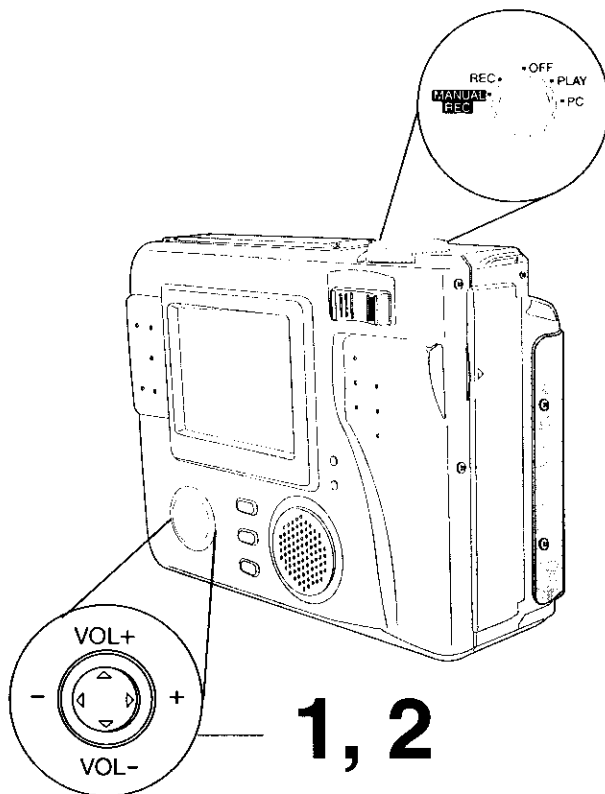

- 1 Press **▲** or **▼** to select **FORMAT** and press **▶** to display **FORMAT** menu.

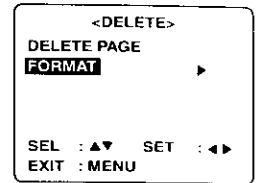

- 2 Press **▲** or **▼** to select **YES**.

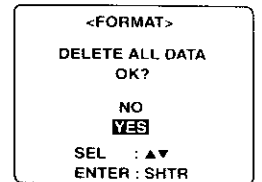

- To exit this menu, press **▲** or **▼** to select **NO** and press **SHTR**.

- 3 Press **SHTR** to format.



- "PLEASE WAIT" will be displayed on screen as all images are deleted from memory. Deletion is complete when "NO IMAGE" is displayed.

Important:

- While "PLEASE WAIT" is displayed, do not turn off the **Digital Camera** or unplug the **AC Adaptor** (supplied) because this will cause irreversible damage to the memory, resulting in reduced image storage capacity.
- When a Floppy Disk formatted with Macintosh is inserted, **DISK ERROR** is displayed and formatting cannot be done.

To Copy Image Pages

You can copy specific images from one Disk Media to another Disk Media using this operation.

Before you begin

Set the **POWER Switch** to **PLAY**. (See pages 19~20.)

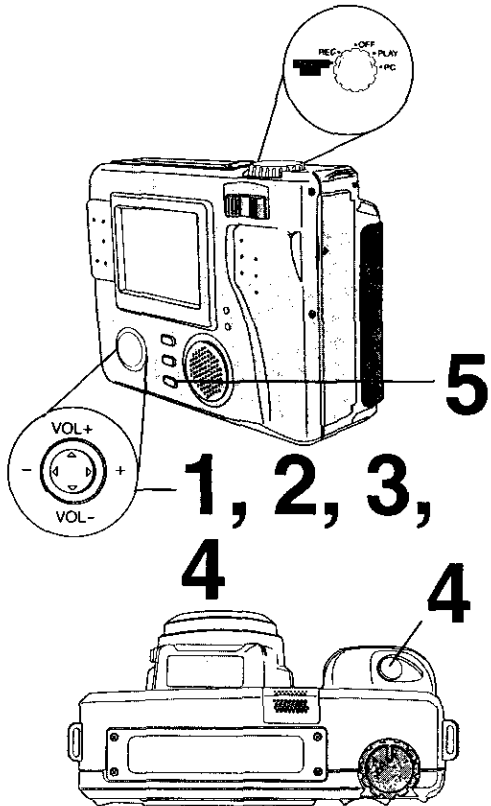

Important:

- While "PLEASE WAIT" is displayed, **do not turn off the Digital Camera or unplug the AC Adaptor** (supplied) because this will cause irreversible damage to the memory, resulting in reduced image storage capacity.

Note

- If the memory capacity of the Disk Media that you want to copy to is not sufficient, the following message will appear.

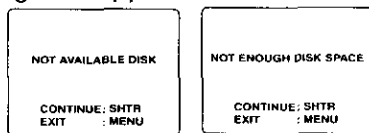

- You can copy images from a SuperDisk Diskette to another SuperDisk Diskette providing the **TARGET** disk has enough space. You can copy images from a Floppy Disk to another Floppy Disk or a SuperDisk Diskette providing the **TARGET** disk has enough space.

- 1 Press **▲** or **▼** to select **COPY**.

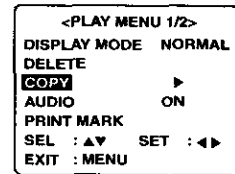

- 2 Press **▶** to display **COPY** menu and select **COPY PAGE**.

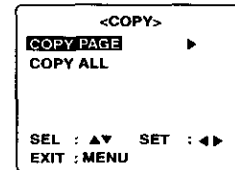

- 3 Press **▶** to display **COPY PAGE** menu.

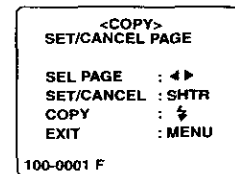

- 4 Press **◀** or **▶** to select image you want to copy and **press SHTR** to stamp copy mark. A "C" mark will appear on the image.

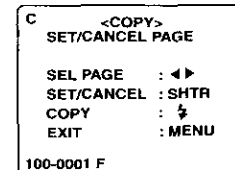

- Repeat step 4 to stamp other images.
- Press **SHTR** again to cancel copy mark.

- 5 Press **⚡** to copy.

- "PLEASE WAIT", then "PLEASE CHANGE DISK" is displayed. After Disk is changed, "PLEASE WAIT" is displayed as images are copied. When copying is complete, the screen below will be displayed.

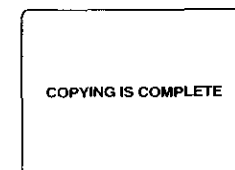

- Press **MENU** twice to exit.

To Copy All Images

You can copy all of the images stored on a Disk Media to another Disk Media using this operation.

Before you begin
Set the **POWER Switch** to **PLAY**. (See pages 19~20.)

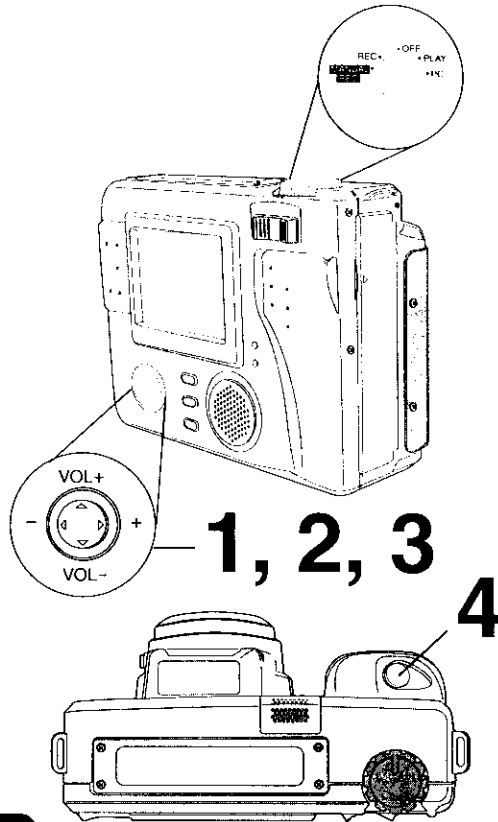

Note

- When copying images from one disk to another, the images are temporarily stored in camera memory before being copied to the target disk. As the camera memory is only equal to about one Floppy Disk, all the SuperDisk Diskette images cannot be stored and COPY ALL cannot be used. If COPY ALL is selected when SuperDisk is the source, "CANNOT COPY ALL THE SUPERDISK" will be displayed.
- If the memory capacity of the SuperDisk Diskette or Floppy Disk that you want to copy to is not sufficient, the following message will appear.



- You can copy images from a Floppy Disk to another Floppy Disk or a SuperDisk Diskette providing the TARGET disk has enough space.

1 Press **▲** or **▼** to select **COPY**.

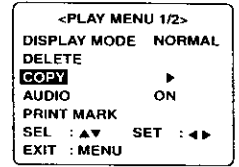

2 Press **▶** to display **COPY** menu and select **COPY ALL**.

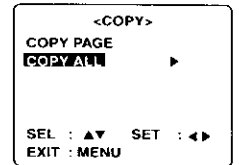

3 Press **▶** to display **COPY ALL** menu and press **▲** or **▼** to select **YES**.

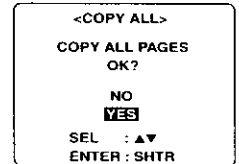

- Select **NO** to return to the **COPY MENU**.

4 Press **SHTR** to copy.



- "PLEASE WAIT", then "PLEASE CHANGE DISK" is displayed. After Disk is changed, "PLEASE WAIT" is displayed as all of the images are copied. When copying is complete, the screen below will be displayed.

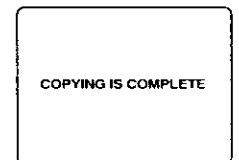

- Press **MENU** twice to exit.

Important:

- While "PLEASE WAIT" is displayed, **do not turn off the Digital Camera or unplug the AC Adaptor** (supplied) because this will cause irreversible damage to the memory, resulting in reduced image storage capacity.

Slide Show

You can playback captured images as a slide show.

Before you begin

Set the POWER Switch to PLAY. (See pages 19~20.)

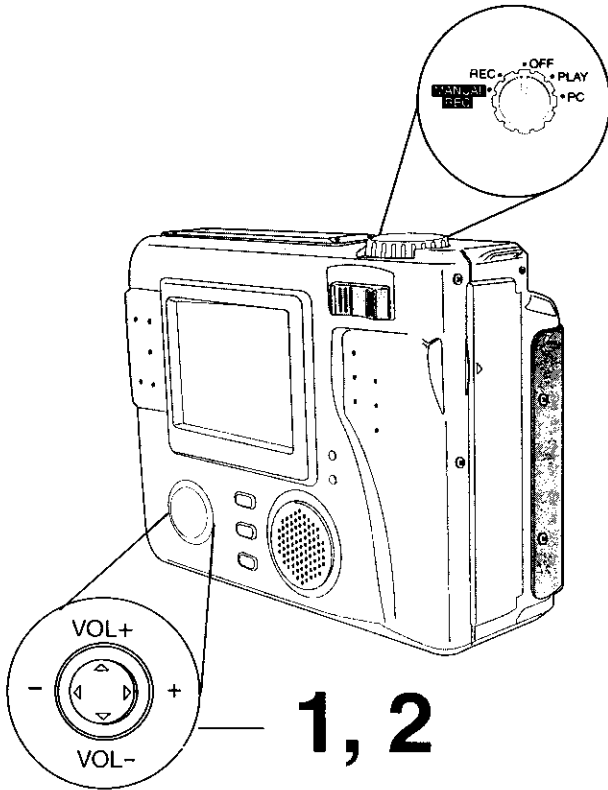

1 Press ▲ or ▼ to select SLIDE SHOW.

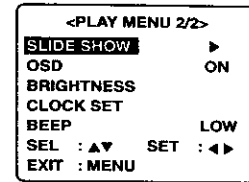

2 Press ▶ to start slide show.

SLIDE SHOW START
PUSH MENU TO EXIT

• Press **MENU** to exit this mode.

SLIDE SHOW STOP

Note

- SLIDE SHOW automatically stops after approx. 20minutes.

Important:

- SLIDE SHOW during execution, **do not turn off the Digital Camera or unplug the AC Adaptor** (supplied) because this will cause irreversible damage to the memory, resulting in reduced image storage capacity.

Transferring Your Images (Windows 98)

System Requirements:

- IBM PC/AT or compatible
- Windows 98 (Pre-installed PC with USB port)
- 486 CPU or higher (Pentium recommended)
- 32MB on-board memory
- 10MB available hard disk space
- 256 Color Monitor or Full Color Monitor recommended (24bits per pixel or 16.7 million colors)
- CD-ROM drive (for installation)
- USB Port
- Mouse or other pointing device

USB Driver Installation

- 1** Turn on the PC (Personal Computer) and start up Windows 98.
- 2** Insert supplied Software CD-ROM into the CD-ROM Drive.
- 3** Click the “Start” button and then click “Run”.



- 4** Type in “D:\Panasonic\Driver\Setup.exe” and then click “OK”.

Note “D” Denotes the CD-ROM drive designation.

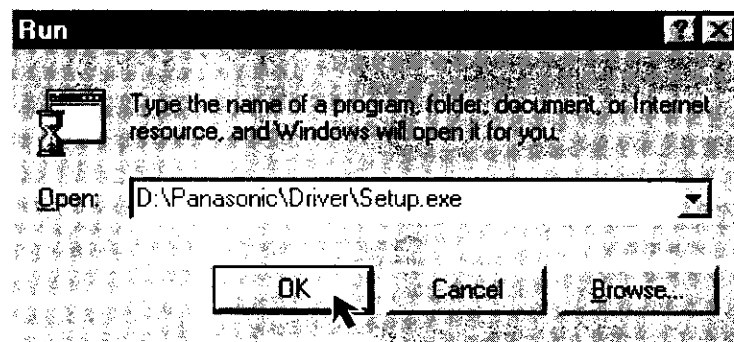

- 5** Follow the instructions as they appear on your PC screen.

Transferring Your Images (Windows 98)

PalmCam File Converter Installation

- When transferring non-Design rule for Camera File system format images from your PC to the Digital Camera, you will need to convert the images data to Design rule for Camera File system format so that the Camera can read it.

Note

- The Design rule for Camera File system was standardized by the Japan Electronic Industry Development Association (JEIDA) with the main purpose of developing an environment in which image files such as those from Digital Still Cameras can easily be exchanged with other related devices.

1 Turn on the PC (Personal Computer) and start up Windows 98.

2 Insert supplied Software CD-ROM into the CD-ROM Drive.

3 Click the “Start” button and then click “Run”.

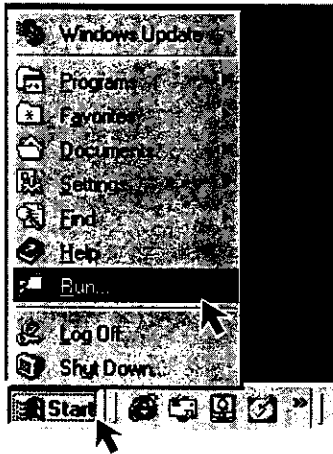

4 Type in “D:\Panasonic\Palmcam\Setup.exe” and then click “OK”.

Note “D” Denotes the CD-ROM drive designation.

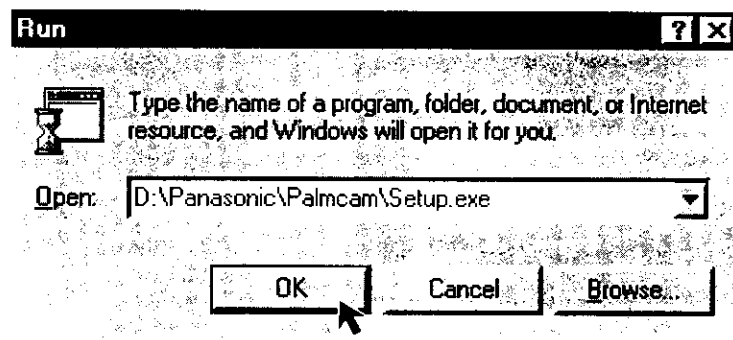

5 Follow the instructions as they appear on your PC screen.

Transferring Your Images (Windows 98)

QuickTime™ Driver Installation

- The QuickTime™ Driver, when installed, allows your Digital Camera to transfer Motion Image Recording files to your PC.

Note

- For information on Apple QuickTime, visit their website at :<http://www.info.apple.com/info.apple.com/support/>

1 Turn on the PC (Personal Computer) and start up Windows 98.

2 Insert supplied Software CD-ROM into the CD-ROM drive.

3 Click the “Start” button and then click “Run”.

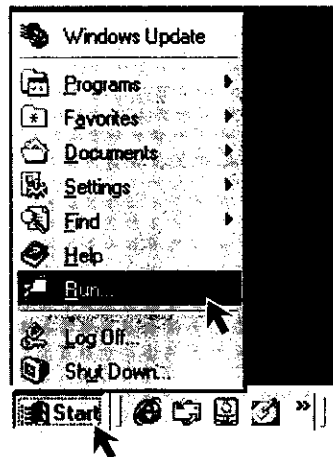

4 Type in “D:\QTM\QuickTimeInstaller.exe” and click “OK”.

Note “D” Denotes the CD-ROM drive designation.

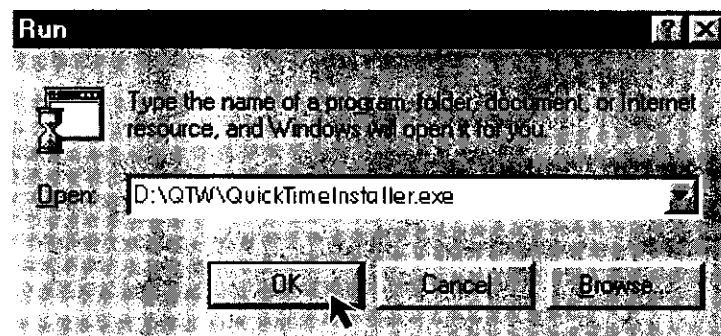

5 Follow the instructions as they appear on your PC screen.

QuickTime and the QuickTime logo are trademarks used under license. QuickTime is registered in the U.S, and other countries.



Transferring Your Images (Windows 98)

By using the included USB cable to connect to a PC, you can use your SuperDisk camera as an external storage device.

*The SuperDisk Diskette is only supported by Windows® 98 or Mac OS 8.1 or later. For other operating systems, you should use Floppy Disk.

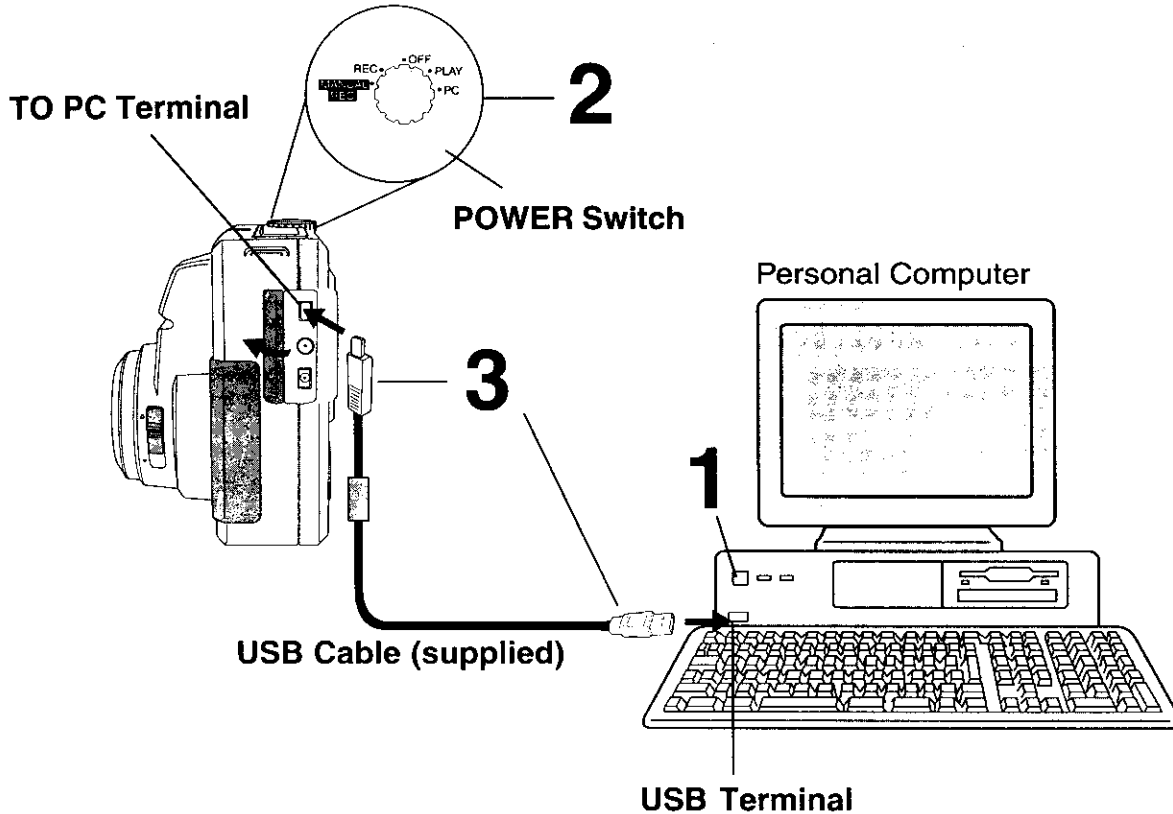

Connection

- 1** Turn on your PC.
- 2** Set the **POWER Switch** to **PC** on the Digital Camera.
 - The POWER LED lamp lights up.
 - LCD Viewfinder is off in PC mode.
- 3** Connect the Digital Camera to your PC (Windows) using the USB Cable (supplied).
 - You can use this Digital Camera as a SuperDisk Drive. (See pages 61, 62, 63, 65.)

Note

- For extended periods of use, it is recommended to use the AC Adaptor (supplied) as a power source.
- Once the USB driver is installed, the Digital Camera can be connected even after the PC has been started. The USB Cable (supplied) must be connected as described in the above steps.

Transferring Your Images (Windows 98)

Reading and Writing the Disk Media

To read or write to the Disk Media using Windows 98 follow the instructions below.

Before you begin
Set the POWER Switch to PC.

Connect the Digital Camera to the PC using the supplied USB Cable, refer to page 48 for additional details.

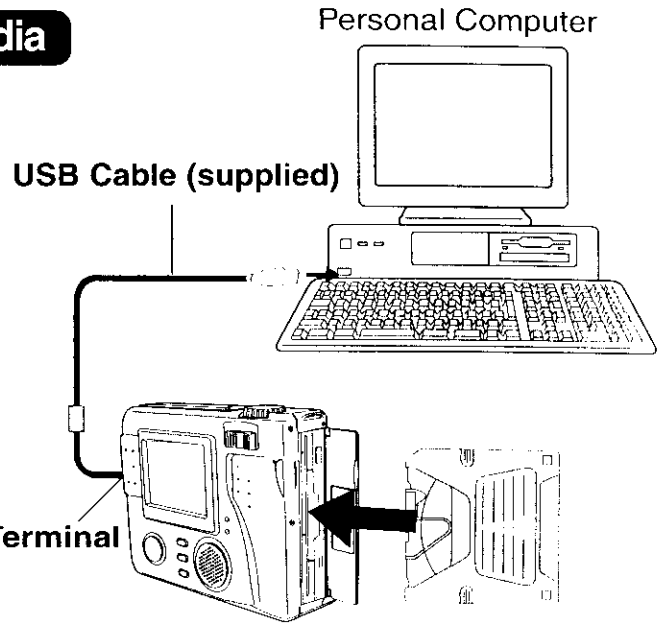

Reading the Disk Media

- 1 Insert the Disk Media into the Digital Camera slot.
- 2 Click "Start", "Programs" and "Image Viewing Software (for Example : PHOTODELUXE)".
Click "Adobe", "PhotoDeluxe Home Edition 3.1" and "Adobe PhotoDeluxe Home Edition 3.1".
The initial screen of the Image Viewing Software is displayed.

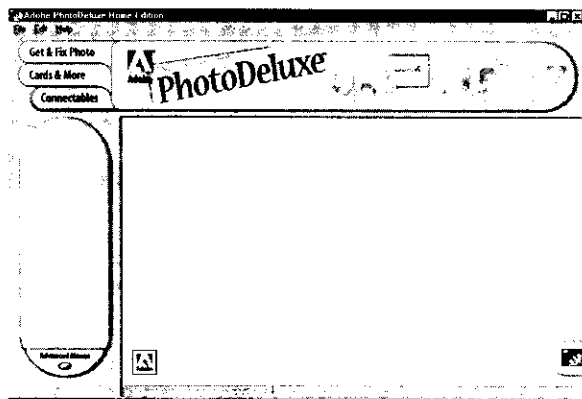
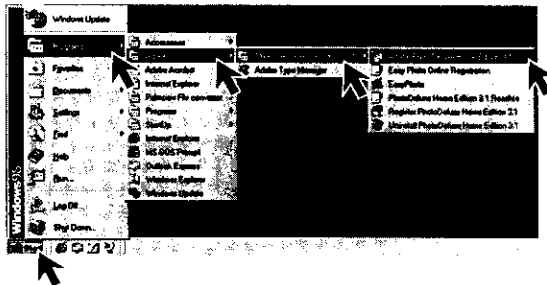

Note

- When playing back Motion images, start QuickTime.

(Continued on next page)

Transferring Your Images (Windows 98)

- 3** Click on the “File” Menu and “Open File”.
The File Open MENU is displayed.

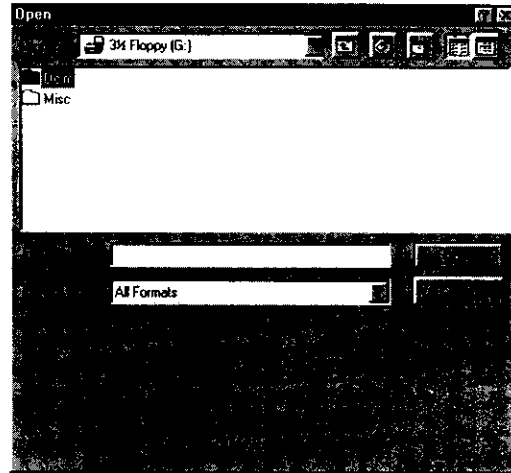
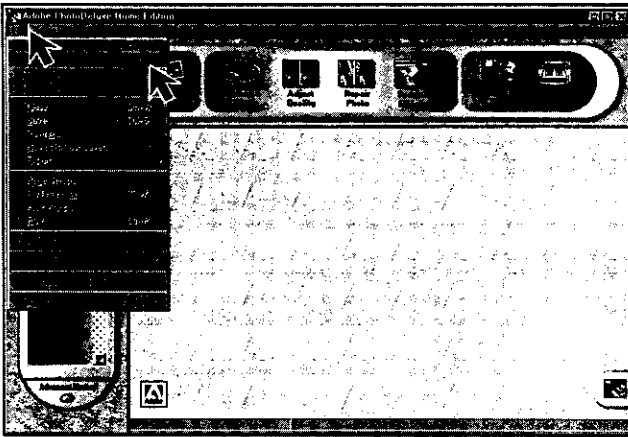

Select the 3.5" FD Drive for the Digital Camera and find the image data file in the Digital Camera.

- When the Digital Camera POWER Switch is set to PC, the Digital Camera Drive is recognized as the 3.5" FD Drive with the latest drive letter, for example (G:).
- The Camera Disk consists of Dcim and Misc Folders.
- The Dcim Folder is used to store image data, and the Misc Folder is used to store Print Mark data.
- Image data is stored in the “100 Pana” folder with the file number starting from “P1000001”. When the 1000th image data is written, the “101 Pana” folder is created and the file number starts from “P1010001”.
- The file numbers once deleted cannot be used.
- If the file number is changed, the Digital Camera cannot read the file.

- 4** Open the image to View the image.

Note

- End all the applications, if, after playing back a Motion image, etc. with "QuickTime", you want to change from PC mode to another mode. Only change from PC mode while a message, such as the one shown at the right is displayed.



Transferring Your Images (Windows 98)

Writing to the Disk Media

- 1 Insert the Disk Media into the Digital Camera slot.
- 2 Click “Start”, “Programs”, and “Windows Explorer”.



- 3 You can write to the Disk Media by simply dragging and dropping a file or folder from the Digital Camera Drive to another Drive. You can also drag and drop a file or folder from another Drive to the Drive of the Digital Camera.

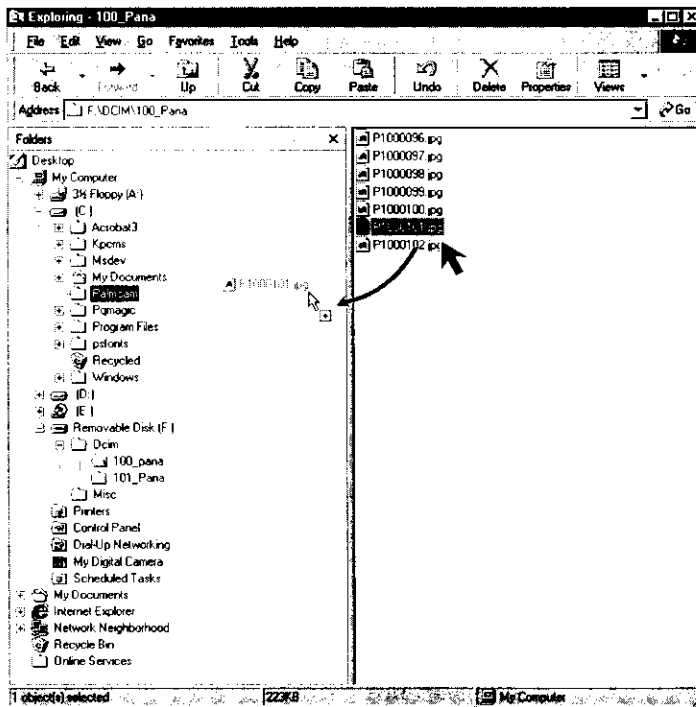

Transferring Your Images (Windows 98)

PalmCam File Conversion

When the Digital Camera can not playback the image data which is transferred from another Drive to the Drive of the Digital Camera, even if the data is JPEG, PalmCam File Conversion is necessary.

Before you begin
Set the POWER Switch to PC.

Connect the Digital Camera to the PC using the supplied USB Cable, refer to page 48 for additional details.

1 Insert the Disk Media into the Digital Camera. (See page 17.)

2 Click the "Start", "Programs", "Palmcam File Converter" and "PalmCam File Converter".

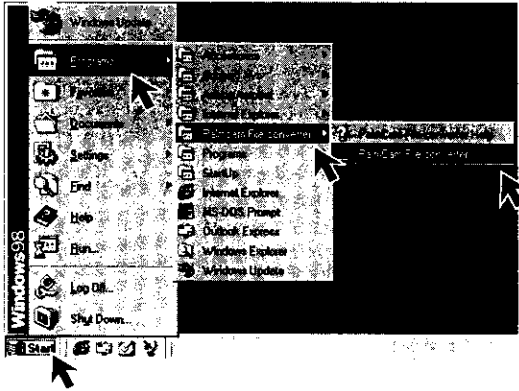

3 Click "File Selection" then select all images to be converted, select camera drive, click on "Convert".

- You can convert the format of the image data from your PC to the Digital Camera.

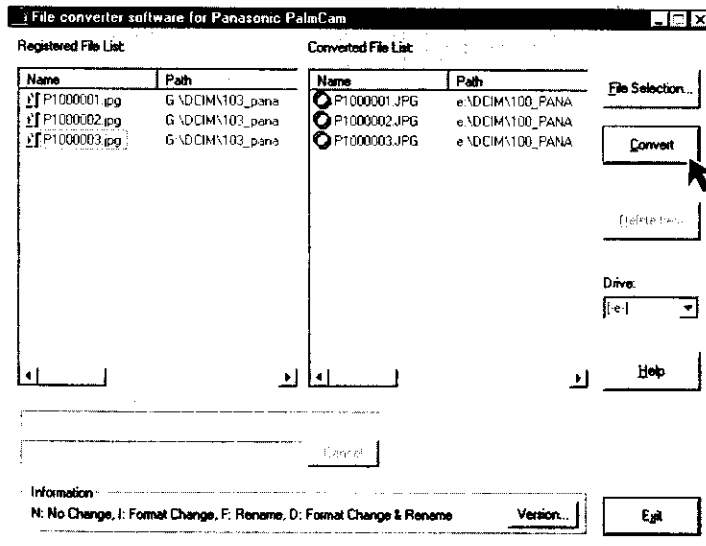

- Use the "Help" of "PalmCam File Converter" for the instructions in detail.

Transferring Your Images (Windows 98)

Deleting a File (Folder) from the SuperDisk Drive

To delete a file (folder) from the Digital Camera.

- Click on the file or folder you want to delete. Then from the "File" menu click on "Delete" to delete the file.

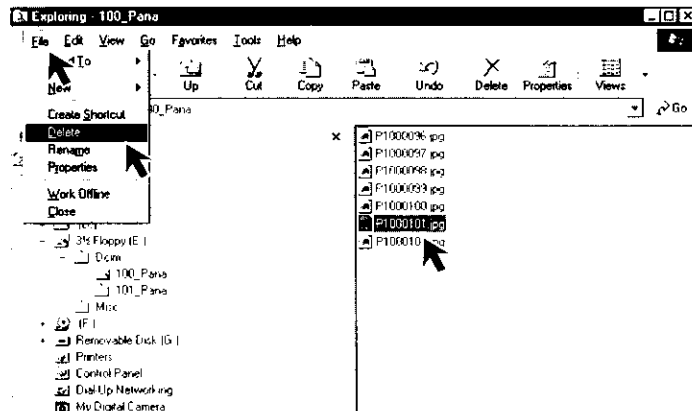

Disconnection

1 End all applications and close all windows. (i.e. QuickTime, PhotoDeluxe, etc.)

2 Eject the Disk Media from the Digital Camera. (See page 17.)

- You can also remove the Disk Media by right clicking on the SuperDisk Drive icon in "Windows Explorer" and "My Computer" and then clicking on "Eject".

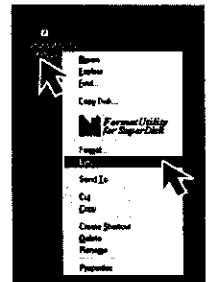

3 Disconnect the USB Cable (supplied) from your PC and change the POWER Switch on the Digital Camera setting from PC mode to another selection. Make sure that all of the applications and all of the windows are closed. Then press the SHTR button.

Note

- If the USB Cable (supplied) is connected before the AC Adaptor is connected, or, if the AC Adaptor is disconnected before the USB Cable is disconnected, it is possible that Windows 98 will abort the operation.
- The USB Cable (supplied) must be disconnected as described in the above steps.

Transferring Your Images (Macintosh)

System Requirements:

- Mac OS 8.1, 8.5, 8.5.1, 8.6
- iMac or Power Macintosh G3 with USB Port
- 32MB of RAM
- 10MB available hard disk space
- 256 Color Monitor or Full Color Monitor recommended (24bits per pixel or 16.7 million colors)
- CD-ROM drive (for installation)
- USB Port
- Mouse or other pointing device

USB Driver Installation

- 1** Turn on the Macintosh.
- 2** Insert the supplied Software CD-ROM into the CD-ROM Drive.
- 3** Double click the "PHOTODELUXE".
- 4** Double click on "Panasonic", "PalmCam" and "DSC&SuperDisk Driver".
- 5** Follow the instructions as they appear on your PC screen.



When the USB Driver is installed, the following changes will occur.

- The Mac OS ROM in the Mac OS 8.1 system folder is changed from 1.1 to 1.1.2.
- The USB Driver of the SuperDisk Drive is installed in the function expansion folder of the System folder.
- Inquire about Mac OS and Firmware updates at the Apple Computer Inc. web site (<http://www.apple.com/>).

Transferring Your Images (Macintosh)

QuickTime™ Driver Installation

- The QuickTime™ Driver, when installed, allows your Digital Camera to transfer Motion Image Recording files to your PC.

Note

- For information on Apple QuickTime, visit their website at :<http://www.info.apple.com/info.apple.com/support/>

- 1** Turn on the Macintosh.
- 2** Insert the supplied Software CD-ROM into the CD-ROM Drive.
- 3** Double click the “PHOTODELUXE”.
- 4** Double click on “QT 4.02” and “QuickTime Installer”.
- 5** Follow the instructions as they appear on your PC screen.

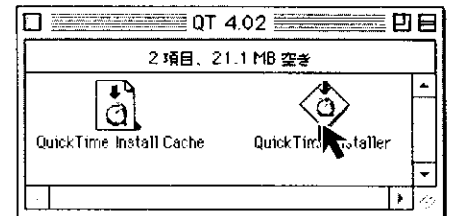

PalmCam File Converter Installation

- The Mac software is currently not available, but will be available in the future on our website at www.panasonic.com/palmcam or by calling 1-800-272-7033.

Transferring Your Images (Macintosh)

By using the included USB cable to connect to a PC, you can use your SuperDisk camera as an external storage device.

*The SuperDisk Diskette is only supported by Windows® 98 or Mac OS 8.1 or later. For other operating systems, you should use Floppy Disk.

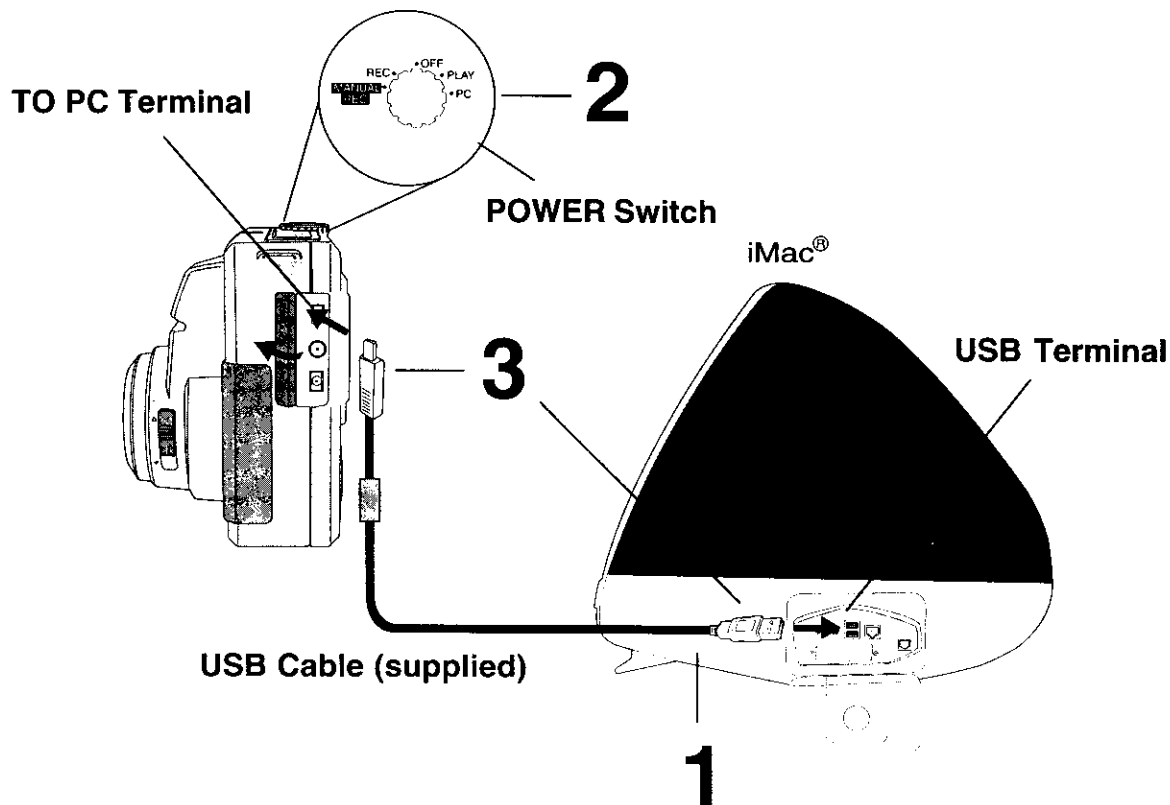

Connection

- 1** Turn on your PC.
- 2** Set **POWER Switch** to **PC** on the Digital Camera.
 - The **POWER LED** lamp lights up.
 - **LCD Viewfinder** is off in **PC** mode.
- 3** Connect the **Digital Camera** to your **PC** using the **USB Cable (supplied)**.
 - You can use this **Digital Camera** as a **SuperDisk Drive**. (See pages 61, 64, 65.)

Note

- For extended periods of use, it is recommended to use the **AC Adaptor (supplied)** as a power source.
- Once the **USB driver** is installed, the **Digital Camera** can be connected even after the **PC** has been started. The **USB Cable (supplied)** must be connected as described in the above steps.

Transferring Your Images (Macintosh)

Reading and Writing the Disk Media

To read or write to the Disk Media using Macintosh follow the instructions below.

Before you begin

Set the POWER Switch to PC.

Connect the Digital Camera to the PC using the supplied USB Cable, refer to page 56 for additional details.

USB Cable (supplied)

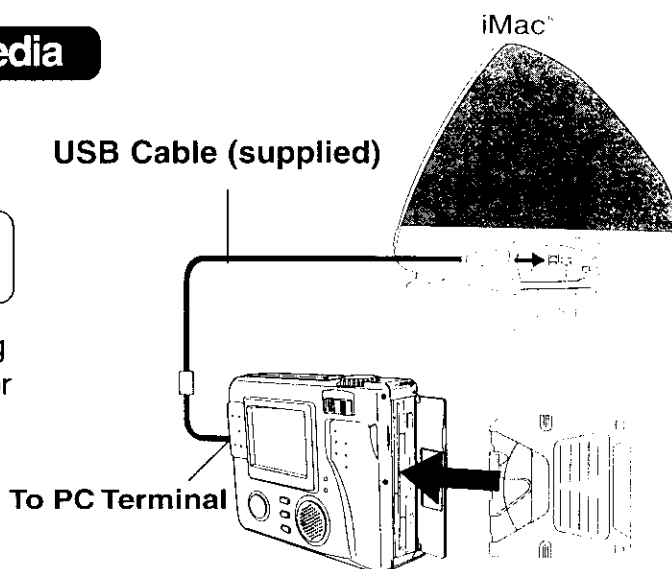

Reading the Disk Media

- 1 Insert the Disk Media into the Digital Camera slot.
- 2 Click “Apple Menu”, “Macintosh HD”, “Adobe PhotoDeluxe™ 2.0” and “Adobe PhotoDeluxe™”.
The initial screen of the Image Viewing Software is displayed.

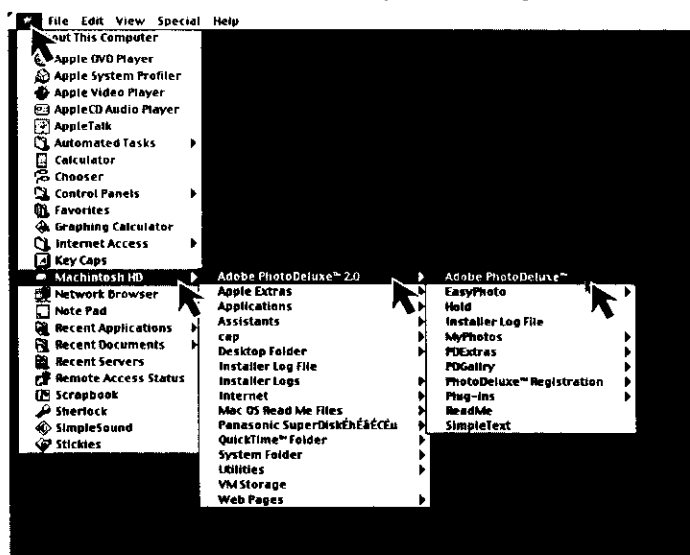

Note

- When playing back Motion images, start QuickTime.

Transferring Your Images (Macintosh)

- 3** Click on the "File" Menu and "Open File".
The File Open MENU is displayed.

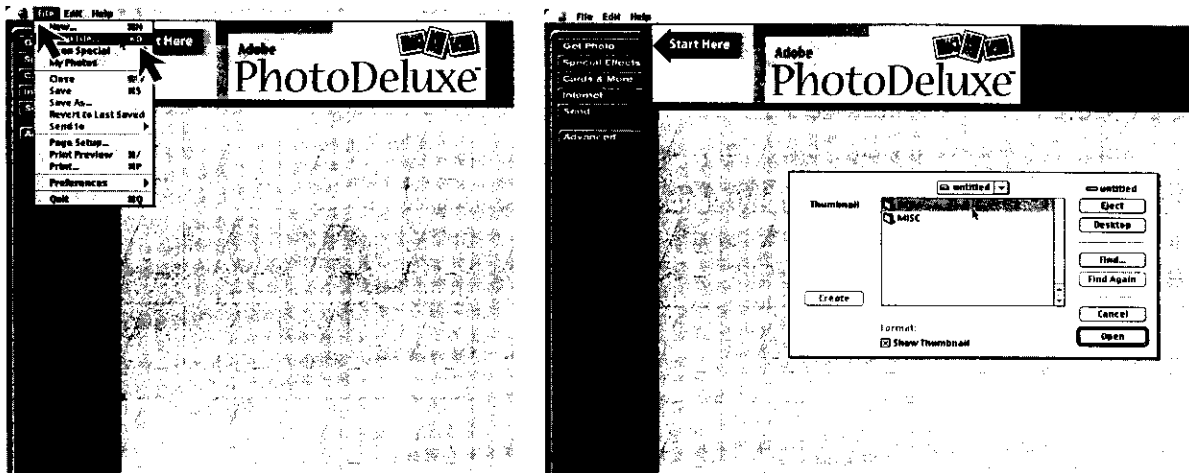

Select the 3.5" FD Drive for the Digital Camera and find the image data file in the Digital Camera.

- When the Digital Camera POWER Switch is set to PC, the Digital Camera Drive is recognized as the 3.5" FD Drive.
- The Camera Disk consists of DCIM and MISC Folders.
- The DCIM Folder is used to store image data, and the MISC Folder is used to store Print Mark data.
- Image data is stored in the "100 PANA" folder with the file number starting from "P1000001". When the 1000th image data is written, the "101 Pana" folder is created and the file number starts from "P1010001".
- The file numbers once deleted cannot be used.
- If the file number is changed, the Digital Camera cannot read the file.

- 4** Open the image to View the image.

Note

- End all the applications, if, after playing back a Motion image, etc. with "QuickTime", you want to change from PC mode to another mode. Only change from PC mode while a message, such as the one shown at the right is displayed.



Transferring Your Images (Macintosh)

Writing to the Disk Media

1 Insert the Disk Media into the Digital Camera slot.

2 Click the icon displayed on the desktop.



3 You can write to the Disk Media by simply dragging and dropping a file or folder from Digital Camera Drive to another Drive.

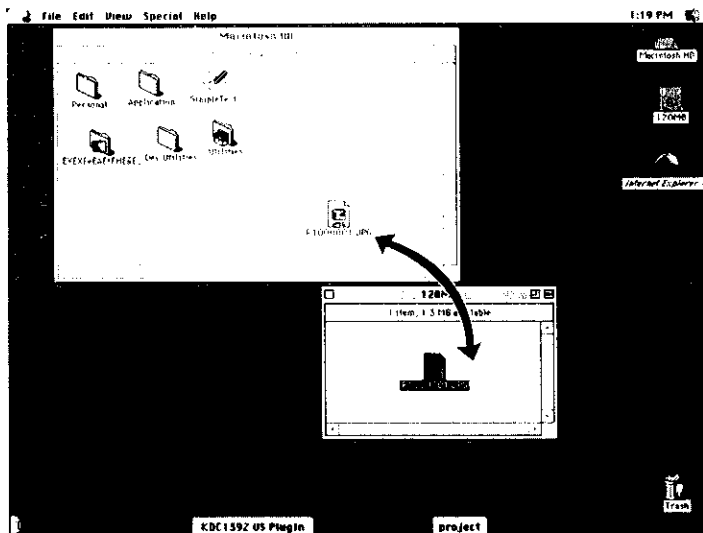

Deleting a File (Folder) from the SuperDisk Drive

To delete a file (folder) from the Digital Camera.

- Drag and Drop the selected file or folder into the “Trash” icon.

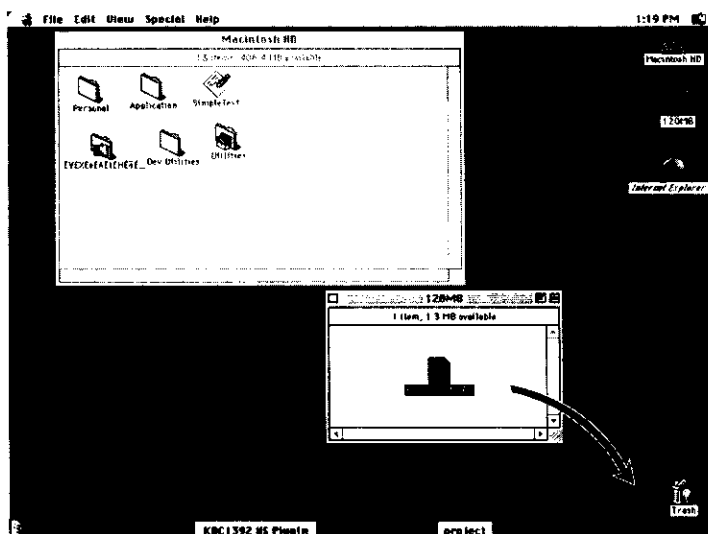

Transferring Your Images (Macintosh)

Disconnection

- 1** End all applications and close all windows. (i.e. QuickTime, PhotoDeluxe, etc.)
- 2** Eject the Disk Media from the Digital Camera. (See page 17.)
- 3** Disconnect the USB Cable (supplied) from your PC and change the POWER Switch on the Digital Camera setting from PC mode to another selection. Make sure that all of the applications and all of the windows are closed. Then press the SHTR button.

Note

- If the USB Cable (Supplied) is connected before the AC Adaptor is connected, or, if the AC Adaptor is disconnected before the USB Cable is disconnected, it is possible that Macintosh will abort the operation.
- The USB Cable (supplied) must be disconnected as described in the above steps.

Removing the Disk Media

- When the PC recognizes the Disk Media, an icon, like the one shown right, is displayed on the desktop.
- You can remove Disk Media from the Digital Camera by dragging and dropping the Disk Media icon on the desktop into the "Trash" icon.
- While the PC is starting up, the Disk Media cannot be removed, even if the EJECT button on the Digital Camera is pressed.
- When a damaged Disk Media is inserted in the Digital Camera, the Disk Media icon will not appear on the PC desktop. In this case, the Disk Media can be removed by pressing the EJECT button on the Digital Camera.

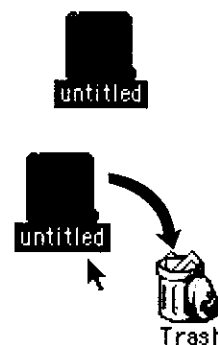

You can use this Digital Camera as an external SuperDisk storage drive. You can only use SuperDisk Diskette media or 2HD Floppy Disks in this camera.

Note

- When a DOS formatted Floppy Disk is read by a Macintosh, the PC/File Exchange function will be necessary.

Media Format Type & Explanation

Type	Format Style	Explanation	Note
SuperDisk Diskette	DOS Format (120MB)	This format is usable with DOS and Windows.	This format is usable with Windows and Macintosh.
Floppy Disk (2HD)	DOS Format (1.44MB)	This format is usable with DOS and Windows.	This format is usable with Windows and Macintosh.

Note

Adverse conditions, such as those described below, are confirmed in PC Exchange Ver. 2.2.1 and also File Exchange Ver. 3.0.

- **Do not format a SuperDisk Diskette that is in the DOS format on a Macintosh.** If you use the DOS format with a Macintosh, the SuperDisk Diskette will not be able to be read or written to.

WRITE Protecting the Disk Media

You can prohibit the writing to or deletion of data from the Disk Media by using the PROTECT switch as shown below.

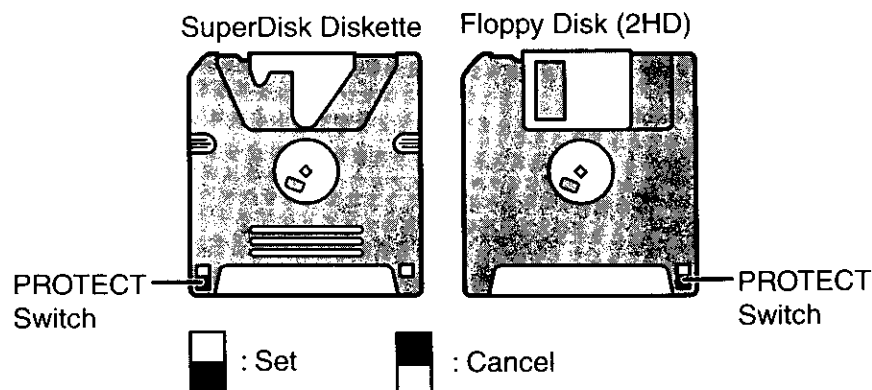

Using the SuperDisk Drive (Windows 98)

Before Formatting

Before formatting the Disk Media, close all applications and all windows. If you format the Disk Media while any of the disk's files are open, an error may occur on the display.

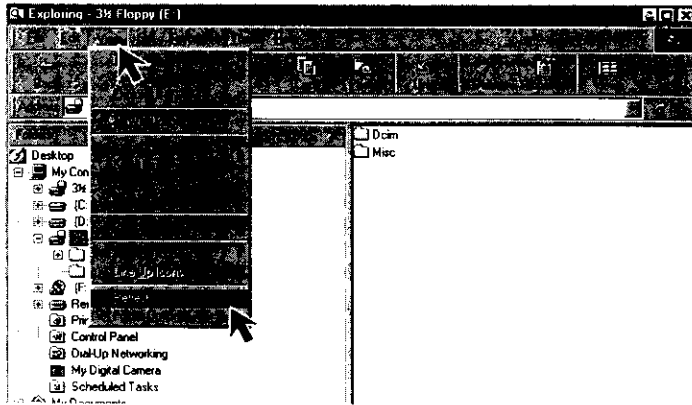

Formatting the Disk Media

1 Insert the Disk Media into the Digital Camera slot.

2 Click "My Computer". Click right mouse button on the Digital Camera icon.

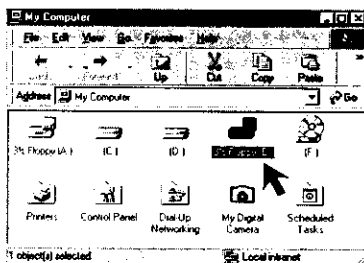

3 Click "FormatUtility for SuperDisk".

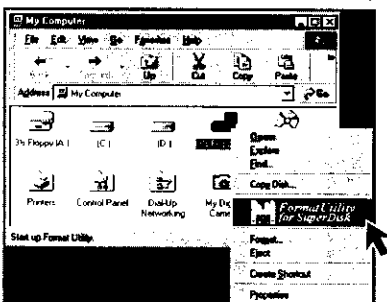

4 Follow the instructions as they appear on your PC screen.

Using the SuperDisk Drive (Windows 98)

Copying the Disk Media

- The DISKCOPY command at the DOS prompt cannot be used.

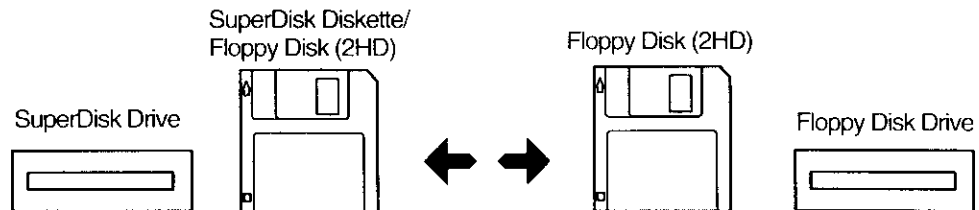

- Disk copy cannot be performed with SuperDisk Diskette.

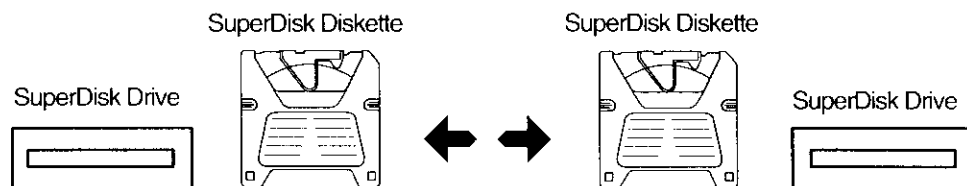

- Explorer CopyDisk is only possible with 2HD Floppy Disk.

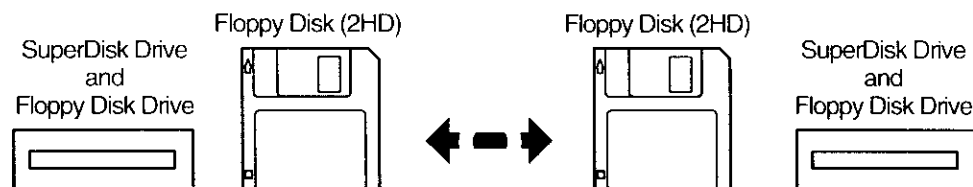

When using Windows Explorer, etc. and you attempt to copy a previously used 2HD Floppy Disk from the Floppy Disk Drive to the Digital Camera with the CopyDisk utility, please note the following.

After PC start up, when CopyDisk is attempted the first time, a Windows error message box may be displayed and CopyDisk may fail.

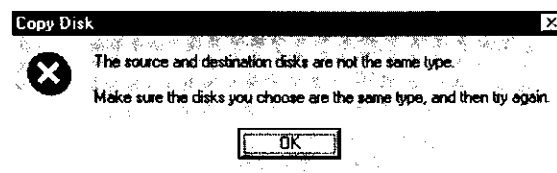

In this case, switch the source Floppy Disk and the target Floppy Disk so that CopyDisk is performed from the Digital Camera to the Floppy Disk Drive. By doing this, CopyDisk will function properly.

Using the SuperDisk Drive (Macintosh)

Formatting the Disk Media

Note

- Do not format the Disk Media under DOS format with Macintosh.

1 Insert the SuperDisk Diskette or Floppy Disk into the Digital Camera slot.

2 Click the SuperDisk Diskette or Floppy Disk icon displayed on the desktop.



3 Select "Erase Disk" in the "Special" MENU.

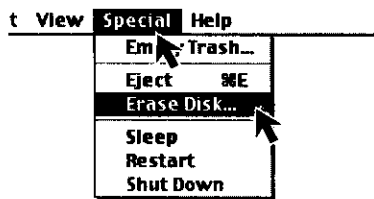

4 Select format style. Then, click "Erase".

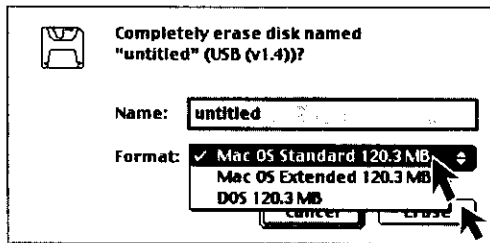

Note

- When using the Disk Media that was formatted to Mac OS standard format or Mac OS expanded format in the Digital Camera, format again in the Digital Camera.
- When "File Sharing" is used, formatting may be impossible. In this case, either quit "File Sharing" or turn AppleTalk off in the control panel.
- In Camera mode (REC, MANUAL REC, PLAY), only PC Exchange Ver. 2.2.1 in DOS format can be used.

Using the SuperDisk Drive

Important Operating Notes

- **FORMAT command cannot be used.**

The FORMAT command at the DOS prompt cannot be used for the Digital Camera.

- **DISKCOPY command cannot be used.**

The DISKCOPY command at the DOS prompt cannot be used for the Digital Camera.

- **You cannot boot your PC from this Digital Camera.**

- **When using the Digital Camera, never remove the Disk Media while data is being written to it.**

If the Disk Media is removed while it is being written, it may become completely unusable.

- **When a Defective Disk is inserted into the Digital Camera, it will take a longer than usual time for the drive to recognize the disk.**

This is normal, so please wait for a while.

- **If the Disk Media is not inserted into the SuperDisk Drive, "FormatUtility for Super Disk" will not be displayed.**

Insert the Disk Media. After the busy light goes out, right click on the SuperDisk icon.

- **According to the use limitations of "QuickTime for Windows", files stored in the SuperDisk Driver may not play back normally.**

- **Unable to place in Suspend/ Resume mode.**

While the SuperDisk Driver is reading/writing to the Disk Media, please do not place in Suspend/ Resume mode.

- **This Digital Camera is not compatible with Flash Pass.**

- **Using a head cleaner caution.**

When using a head cleaner, please use the product described below and limit cleaning to about 7 seconds.

Name of article : Imation 3.5" Dry Head Cleaning Disk
Article No. : 74040183035

Print Mark

Use this feature when a laboratory service that supports DPOF (Digital Print Order Format) is used.

Before you begin

Set the **POWER** Switch to **PLAY**. (See pages 19~20.)

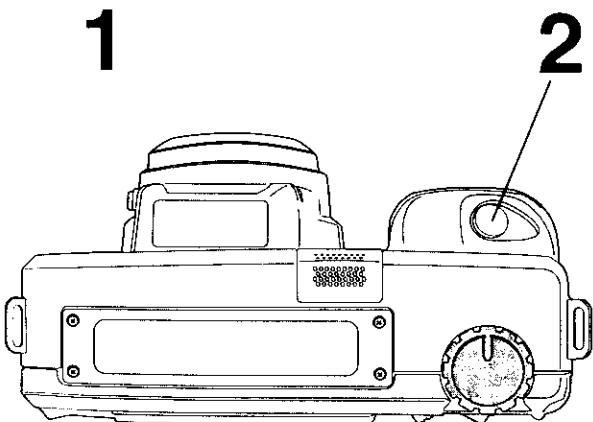
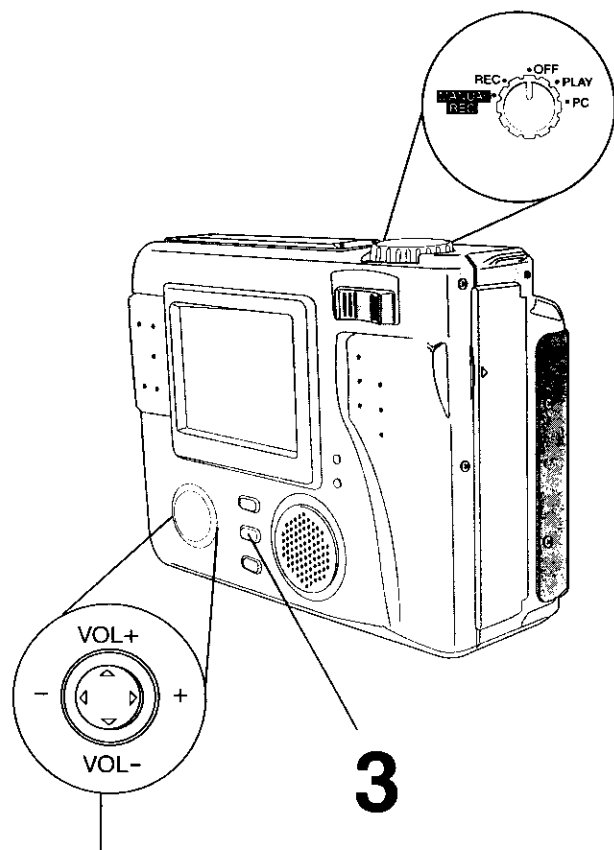

Stamp Print Marker

- 1 Press **▲** or **▼** to select **PRINT MARK** and press **▶** to display **PRINT MARK** menu.

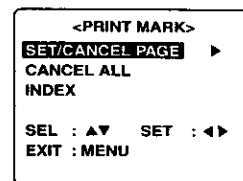

- Select "SET/CANCEL PAGE" to select image, "CANCEL ALL" to cancel all image print marks, and "INDEX" to set or clear index print on all pages.

- 2 Press **◀** or **▶** to select the image page you want to mark for printing and press **SHTR** to stamp print mark. A "O" mark will appear on the image. Press **▲** or **▼** to select number of copies to print. (up to 99)

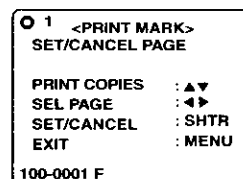

- Repeat step 2 to stamp other images.
- Press **SHTR** again to cancel print mark.

- 3 Press **MENU** to exit this menu.



This print mark is based on DPOF (Digital Print Order Format).

Digital Camera Accessory

For ordering instructions, see the Accessory Order Form page.

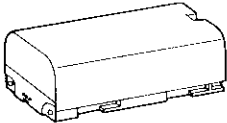
Accessory #	Figure	Description	Price
CGR-B/ 202A1B		Lithium Ion Battery	\$100.00

Digital Camera Accessory Order Form

Please photocopy this form when placing an order.

1. Model # _____

2. Items Ordered

Accessory #	Description	Price Each	Quantity	Total Price
Subtotal				
Your State & Local Sales Tax				
Shipping & Handling				5.00
Total Enclosed				

3. Method of payment (check one)

- Check of Money Order enclosed (NO C.O.D.SHIPMENTS)
- VISA Credit Card # _____
- MasterCard Expiration Date _____
- Discover Customer Signature _____

Make Check or Money Order to: MATSUSHITA ACCESSORIES

(Please do not send cash)

4. Shipping information (UPS delivery requires complete street address)

Ship To:

Mr.

Mrs.

Ms. _____

First Last

Phone #:

Day ()

Street Address

Night ()

City State Zip

TO OBTAIN ANY OF OUR DIGITAL CAMERA ACCESSORIES YOU CAN DO ANY OF THE FOLLOWING:

VISIT YOUR LOCAL PANASONIC DEALER

OR

CALL PANASONIC'S ACCESSORY ORDER LINE AT 1-800-272-7033 [8:30 AM-8 PM M-F, EST]

OR

MAIL THIS ORDER TO: PANASONIC SERVICES COMPANY ACCESSORY ORDER OFFICE
20421 84th Avenue South Kent, WA. 98032

Before Requesting Service

If you have a problem with your Digital Camera, it may be something you can correct yourself.

Check the list below for symptoms and corrections.

Symptom	Solution
Cannot charge the Battery Pack.	<ul style="list-style-type: none"> • Make sure the rechargeable Lithium Ion Battery Pack is attached. (p 13) • Make sure all necessary connections are correct and tight. (p 13)
No power.	<ul style="list-style-type: none"> • Lithium Ion Battery is depleted. (p 14) • Make sure polarities are aligned properly. (p 14) • When the unit is moved from a cold place to a warm place, it may not function. In this case, please wait one hour before using the unit.
Power shuts off automatically.	<ul style="list-style-type: none"> • Auto shut off feature is on. Press SHTR, or set POWER Switch to OFF, and then set to REC or MANUAL REC. (pp 19, 20, 22.)
Cannot capture the image.	<ul style="list-style-type: none"> • SuperDisk Diskette (FD) is not inserted. (p 17) • Make sure the POWER switch is set to REC or MANUAL REC. (pp 19, 20.) • No memory. Delete some images before capturing images. (p 40)
No Picture on the LCD Viewfinder.	<ul style="list-style-type: none"> • Auto shut off feature is on. Set the POWER to OFF and then set to REC or MANUAL REC. (pp 19, 20, 22.)
LCD Viewfinder image is too bright or dark.	<ul style="list-style-type: none"> • Make sure the LCD Viewfinder brightness setting is adjusted properly. (p 28)
Flash will not light.	<ul style="list-style-type: none"> • The flash mode is set to  (OFF) mode. Change flash mode. (p 34)
Cannot playback.	<ul style="list-style-type: none"> • SuperDisk Diskette (FD) is not inserted. (p 17) • There are no images on the SuperDisk Diskette (FD). (pp 22~25.) • Make sure the POWER switch is set to PLAY. (p 20) • PalmCam File Conversion. (p 52)
No picture on the TV (if connected).	<ul style="list-style-type: none"> • Make sure all necessary connections are correct and tight. (p 33) • Make sure the TV is set to video input mode. (p 33)
Can not transfer images on the PC Connection.	<ul style="list-style-type: none"> • Make sure all necessary connections are correct and tight. (pp 48, 56.) • Make sure the SuperDisk Driver is installed. • Set Camera to PC mode. (pp 48, 56.)

Warning Indications







These displays will alert you of a missed operation or provide further instructions.

Indication	Phenomenon	Solution
SYSTEM ERROR	Failed USB handshake.	If, after Power Switch is set to OFF, then REC or PLAY again, SYSTEM ERROR is still displayed, the camera may be broken and needs repair.
DRIVE ERROR	Failed to initialize the drive.	If, after Power Switch is set to OFF, then REC or PLAY again, DRIVE ERROR is still displayed, the camera may be broken and needs repair.
WRITE ERROR	Failed to write.	If the problem occurred while capturing, please capture again. If WRITE ERROR is still displayed, the disk may be defective, or could not be read. Please reinsert the disk or change disks. If the problem occurred while setting a COPY or PRINT MARK, please try again. If WRITE ERROR, repeat this procedure.
READ ERROR	Failed to read.	The camera cannot read this image. Press + or - button to play the next image. A READ ERROR file cannot be delete in DELETE menu. Please format the disk, or delete with the PC.
DISK ERROR (PUSH SHTR TO FORMAT)	Unsuitable disk.	If PUSH SHTR TO FORMAT is displayed, you may format the disk. If PUSH SHTR TO FORMAT is not displayed, the disk cannot be formatted. (Disks that can be formatted were once formatted under DOS or Mac.)
DELETE ERROR	Failed to delete the file.	If, after attempting to delete again, DELETE ERROR is displayed, the disk may be defective. Change disks.
FORMAT ERROR	Failed to format the disk.	If, after attempting to format again, FORMAT ERROR is displayed, the disk may be defective. Change disks.

Warning Indications

Indication	Phenomenon	Solution
THIS DISK IS PROTECTED	The disk is protected.	If THIS DISK IS PROTECTED is displayed, change disks or disengage protect.
NOT ENOUGH MEMORY PUSH MENU TO EXIT	Insufficient disk memory. (1.44MB) Copy capacity was exceeded.	If NOT ENOUGH MEMORY is displayed, delete unnecessary images. Or, decrease or change the images to be copied.
NOT ENOUGH DISK SPACE CONTINUE : SHTR EXIT : MENU	Insufficient space on target disk compared to source disk.	After pressing SHTR to CONTINUE, switch to a disk with enough space, or press MENU to EXIT.
NOT AVAILABLE DISK SPACE CONTINUE : SHTR EXIT : MENU	The disk cannot be copied.	The disk is unusable or protected. After pressing SHTR to CONTINUE, switch to a disk with enough space, or press MENU to EXIT.
CANNOT COPY ALL THE SUPERDISK	Cannot copy all the images.	It is impossible to select ALL COPY when SuperDisk is the source. Please select COPY PAGE to copy.
PLEASE OPEN LENS COVER	Lens Cover is closed.	Please open the Lens Cover.

Specifications

CCD	1/2.7 inch (9.34 mm) 1,320 k Pixels	
Lens	f=5.2-15.6 mm (equivalent to a 34-102 mm lens on a 35 mm still camera.)/F2.8-4.7	
Focus	Auto / Preset (Zone)	
Focusing Area	7.9 inch (20 cm) ∞ (approx.)	
Iris (Shutter Speed)	F2.8/F8 (wide)	
Shutter Speed	1/30-1/750 seconds (Auto), 1/4-1/750 seconds (Slow Shutter mode)	
White Balance	Auto/Indoor/Outdoor/White Set	
LCD Viewfinder	2.5 inch (63.4 mm) TFT Color LCD with 112 k pixels	
Flash	Built-in	
Microphone	Built-in (Mono)	
Speaker	Built-in (Mono)	
Memory	Floppy Disk (1.44 MB)/SuperDisk Diskette(120MB)	
Image Size	1,280 × 960 pixels (Super Fine, Fine) 640 × 480 pixels (Normal, Zoom,  mode) 320 × 240 pixels ( mode)	
Image Storage (Floppy Disk)	Approx. 5 images (Super Fine mode) Approx. 10 images (Fine mode) Approx. 17 images (Normal, Zoom,  mode) 10 sec. × Approx. 1 set ( mode)	
(SuperDisk Diskette)	Approx. 450 images (Super Fine mode) Approx. 900 images (Fine mode) Approx. 1,500 images (Normal, Zoom,  mode) 10 sec. × Approx. 90 sets ( mode)	
Image Format (Still Image With Audio)	JPEG (Design Rule for Camera File System)	
(Motion Image)	JPEG, QuickTime	
Digital Interface	QuickTime (320 x 240 pixel Still image with Audio)	
Video Signal	USB	
Power Supply	NTSC Composite	
Power Consumption	Lithium Ion Battery (1250 mAh, 7.2 V)/AC Adaptor (input 110-240 V AC)	
	Digital Camera	7.2 V, DC 1.8 A
	AC Adaptor (supplied)	input 110/120/220/240 V AC, 50/60 Hz 20 W
Operating Temperature	32 – 104 °F/0 – 40 °C	
Operating Humidity	10 % – 75 %	
Weight	Digital Camera	1.53 lbs approx./695 g approx.
	AC Adaptor (supplied)	0.39 lbs approx./180 g approx
Dimensions	Digital Camera	5-5/8 (W) × 4-3/8 (H) × 3-1/4 (D) inch 143 (W) × 112 (H) × 84 (D) mm
	AC Adaptor (supplied)	3-7/8 (W) × 1-5/8 (H) × 2-7/8 (D) inch 97 (W) × 43 (H) × 73 (D) mm

Weight and dimensions shown are approximate.
Design and specifications are subject to change without notice.

Panasonic Consumer Electronics Company, Division of Matsushita Electric Corporation of America
 One Panasonic Way Secaucus,
 New Jersey 07094

Panasonic Sales Company, Division of Matsushita Electric of Puerto Rico, Inc.
 Ave. 65 de Infantería. Km. 9.5
 San Gabriel Industrial Park, Carolina, Puerto Rico 00985

PANASONIC/QUASAR Video Products Limited Warranty

Panasonic Consumer Electronics Company or Panasonic Sales Company (collectively referred to as "the Warrantor") will repair this product with new or refurbished parts, free of charge, in the USA or Puerto Rico, in the event of a defect in materials or workmanship as follows (all time periods commence from the date of the original purchase):

PRODUCT	PARTS	LABOR
CAMCORDER	ONE (1) YEAR, EXCEPT CCD IMAGE SENSOR	NINETY (90) DAYS
DIGITAL CAMERA	CCD IMAGE SENSOR - SIX (6) MONTHS	NINETY (90) DAYS
VCR	ONE (1) YEAR	NINETY (90) DAYS
A/V MIXER	ONE (1) YEAR	NINETY (90) DAYS
MONITOR-VCR	ONE (1) YEAR, EXCEPT CRT CRT - TWO (2) YEARS	NINETY (90) DAYS CRT- NINETY (90) DAYS CUSTOMER PAYS ALL LABOR CHARGES AFTER 90 DAYS

Monitor-VCR In-home or carry-in Service: 22" (diagonal) CRT / LCD and Larger
Monitor-VCR Carry-in Service: 21" (diagonal) CRT / LCD and smaller

Batteries (if included) - New rechargeable batteries in exchange for defective rechargeable batteries for ten (10) days. Non-rechargeable batteries are not warranted.

Tape (if included) - New video cassette tape in exchange for a defective video cassette tape for five (5) days.

In-home, carry-in or mail-in service, as applicable, in the USA can be obtained during the warranty period by contacting a Panasonic Services Company (PASC) Factory Servicenter listed in the Service Directory. Or call toll free 1-800-272-7033, to locate an authorized PASC Servicenter. Carry-in or mail-in service in Puerto Rico can be obtained during the warranty period by calling the Panasonic Sales Company telephone number listed in the Servicenter Directory.

This warranty is extended only to the original purchaser. A purchase receipt or other proof of the date of the original purchase is required before warranty service is rendered.

This warranty only covers failures due to defects in materials and workmanship which occur during normal use and does not cover normal maintenance, including, but not limited to, video and audio head cleaning. The warranty does not cover damage which occurs in shipment, or failures which are caused by products not supplied by the warrantor, or failures which result from accident, misuse, abuse, neglect, mishandling, misapplication, alteration, modification, faulty installation, set-up adjustments, improper antenna, inadequate signal pickup, maladjustment of consumer controls, improper operation, power line surge, improper voltage supply, lightning damage, commercial use such as hotel, office, restaurant, or other business or rental use of the product, or service by anyone other than a PASC Factory Servicenter or a PASC authorized Servicenter, or damage that is attributable to acts of God.

LIMITS AND EXCLUSIONS

There are no express warranties except as listed above. THE WARRANTOR SHALL NOT BE LIABLE FOR INCIDENTAL OR CONSEQUENTIAL DAMAGES (INCLUDING, WITHOUT LIMITATION, DAMAGE TO TAPES) RESULTING FROM THE USE OF THIS PRODUCTS, OR ARISING OUT OF ANY BREACH OF THE WARRANTY. ALL EXPRESS AND IMPLIED WARRANTIES, INCLUDING THE WARRANTIES OF MERCHANTABILITY AND FITNESS FOR PARTICULAR PURPOSE, ARE LIMITED TO THE APPLICABLE WARRANTY PERIOD SET FORTH ABOVE. Some states do not allow the exclusion or limitation of incidental or consequential damages, or limitations on how long an implied warranty lasts, so the above exclusions or limitations may not apply to you.

This warranty gives you specific legal rights and you may also have other rights which vary from state to state.

If a problem with this product develops during or after the warranty period, you may contact your dealer or Servicenter. If the problem is not handled to your satisfaction, then write to the Customer Satisfaction Center at the Panasonic Consumer Electronics Company address above.

SERVICE CALLS WHICH DO NOT INVOLVE DEFECTIVE MATERIALS OR WORKMANSHIP AS DETERMINED BY THE WARRANTOR, IN ITS SOLE DISCRETION, ARE NOT COVERED. COSTS OF SUCH SERVICE CALLS ARE THE RESPONSIBILITY OF THE PURCHASER.

warvid 10/20/97

Service Center Directory

For Product Information, operating Assistance, Literature Request, Dealer Locations, and all Customer Service inquiries please contact:

1-800-272-7033, Monday-Friday 8:30am-8pm EST.

Web Site: <http://WWW.Panasonic.com>

You can purchase parts, accessories or locate your nearest servicer by visiting our Web Site.

Product Repairs

Centralized Factory Servicer

MAIL TO : Panasonic Services Company
1705 N. Randall Road,
Elgin, IL 60123-7847
Attention: Digital Camera Repair

Please carefully pack and ship, prepaid and insured, to the Elgin centralized repair Factory Servicer. While there will be added handling delays, you may bring your unit to one of the following locations who will then forward the unit to Elgin for repair.
Customer's in Puerto Rico, please ship or carry in to location below ("Service in Puerto Rico").

Factory Servicer Locations

CALIFORNIA

6550 Katella Avenue
Cypress, CA 90630

800 Dubuque Avenue
S. San Francisco,
CA 94080

20201 Sherman Way
Suite 102
Canoga Park, CA 91306

3878 Ruffin Road
Suite A
San Diego, CA 92123

COLORADO

1640 South Abilene
Street Suite D
Aurora, CO 80012

FLORIDA

3700 North 29th Avenue
Suite 102
Hollywood, FL 33020

GEORGIA

8655 Roswell Road
Suite 100
Atlanta, GA 30350

ILLINOIS

1703 North Randall Road
Elgin, IL 60123
(Pick-up / Drop-off only)

9060 Golf Road
Niles, IL 60714

MARYLAND

62 Mountain Road
Glen Burnie MD 21061

MASSACHUSETTS

60 Glacier Drive,
Suite G
Westwood, MA 02090

MICHIGAN

37048 Van Dyke Avenue
Sterling Heights, MI
48312

MINNESOTA

7850-12th Avenue South
Airport Business Center
Bloomington, MN 55425

OHIO

2236 Waycross Road
Civic Center Plaza
Forest Park, OH 45240

PENNSYLVANIA

2221 Cabot Blvd. West
Suite B
Langhorne, PA 19047

Chartiers Valley
Shopping Center
1025 Washington Pike
Bridgeville, PA 15017

TENNESSEE

919-8th Avenue South
Nashville, TN 37203

TEXAS

7482 Harwin Drive
Houston, TX 77036

13615 Welch Road
Suite 101
Farmers Branch,
TX 75244

WASHINGTON

20425-84th Avenue
South
Kent, WA 98032

HAWAII

99-859 Iwaiwa Street
Aiea, Hawaii 96701
Phone (808) 488-1996
Fax (808) 486-4369

Service in Puerto Rico

Matsushita Electric of Puerto Rico, Inc. Panasonic Sales Company/ Factory Servicer:
Ave. 65 de Infantería. Km. 9.5 San Gabriel Industrial Park Carolina, Puerto Rico 00985
Phone (787) 750-4300 Fax (787) 768-2910

Accessory Purchases:

Customer Orders Only 1-800-272-7033

As of October '97

A			
AC Adaptor (Supplied)		2, 13, 15	
AC Cable (Supplied)		2, 13, 15	
Accessory (optional)		67	
Accessory (Supplied)		2	
A/V Cable		2, 33	
B			
Battery Remaining Indication		10	
Beep		27	
Brightness (LCD Viewfinder)		28	
Built-in Flash		34	
C			
Camera Strap		2, 16	
Capturing Images		22, 23, 24, 25, 27	
Copy Image		42, 43	
D			
DC POWER Cable		2, 15	
Delete Image		40	
F			
Formatting the Disk Media		41	
I			
Iris		38	
Index of Controls		8, 9	
L			
LCD Viewfinder		22~25, 28, 29	
Low Light Warning		10	
Light Metering		36	
Lithium Ion Battery		2, 13, 14, 67	
M			
Manual Playback		29	
MENU Screen		19, 20	
Multi Playback		30, 31	
O			
On Screen Display (OSD)		10, 12	
P			
Playback		29, 30, 31, 32	
Playback Menu		12	
POWER Supply		13, 14, 15	
Print Mark (DPOF)		66	
R			
Recording Menu		11	
S			
Self Timer		11, 37	
Setting the Clock		21	
Service Center Directory		74	
Slide Show		44	
Slow Shutter		22, 23	
Special Digital Camera Features		7	
Specifications		72	
SuperDisk		2, 17	
SuperDisk Drive		61~65	
T			
Transferring Images		33, 45~60	
Time Lapse		39	
W			
Warranty		73	
White Balance		35	
Z			
Zoom Playback		32	

**Panasonic Consumer
Electronics Company, Division
of Matsushita Electric
Corporation of America**
One Panasonic Way Secaucus,
New Jersey 07094

**Panasonic Sales Company,
Division of Matsushita Electric
of Puerto Rico, Inc. ("PSC")**
Ave. 65 de Infantería, Km. 9.5
San Gabriel Industrial Park
Carolina, Puerto Rico 00985

Printed in Japan
LSQT0179A
S1199-0