

Operator's Manual

CRAFTSMAN[®]

P R O F E S S I O N A L

3/8 in. PROFESSIONAL ELECTRIC DRILL

Variable Speed / Reversible
Double Insulated

Model No.
315.269390

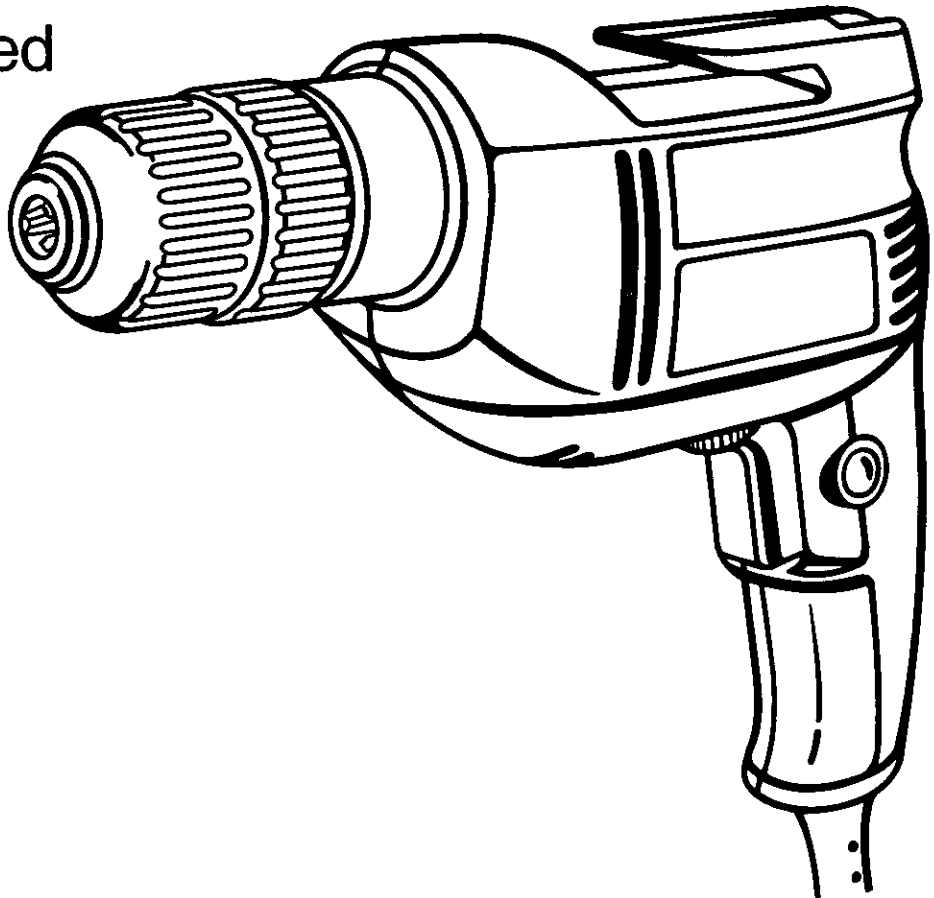

Save this manual for
future reference.

⚠ CAUTION: Read and follow
all Safety Rules and Operating
Instructions before first use of
this product.

Customer Help Line: 1-800-932-3188

Sears, Roebuck and Co., 3333 Beverly Rd., Hoffman Estates, IL 60179 USA
Visit the Craftsman web page: www.sears.com/craftsman

- Safety
- Features
- Operation
- Maintenance
- Parts List



TABLE OF CONTENTS

■ Table of Contents	2
■ General Safety Rules	2-3
■ Specific Safety Rules	4
■ Symbols	5
■ Features	5-6
■ Operation	7-10
■ Maintenance	11
■ Accessories	12
■ Warranty	12
■ Exploded View and Repair Parts List	13
■ Parts Ordering / Service	14

GENERAL SAFETY RULES

⚠ WARNING: Read and understand all instructions. Failure to follow all instructions listed below may result in electric shock, fire, and/or serious personal injury.

SAVE THESE INSTRUCTIONS

Work Area

- **Keep your work area clean and well lit.** Cluttered benches and dark areas invite accidents.
- **Do not operate power tools in explosive atmospheres, such as in the presence of flammable liquids, gases, or dust.** Power tools create sparks which may ignite the dust or fumes.
- **Keep bystanders, children, and visitors away while operating a power tool.** Distractions can cause you to lose control.

Electrical Safety

- **Double insulated tools are equipped with a polarized plug (one blade is wider than the other).** This plug will fit in a polarized outlet only one way. If the plug does not fit fully in the outlet, reverse the plug. If it still does not fit, contact a qualified electrician to install a polarized outlet. **Do not change the plug in any way.** Double insulation  eliminates the need for the three-wire grounded power cord and grounded power supply system.
- **Avoid body contact with grounded surfaces, such as pipes, radiators, ranges, and refrigerators.** There is an increased risk of electric shock if your body is grounded.
- **Don't expose power tools to rain or wet conditions.** Water entering a power tool will increase the risk of electric shock.
- **Do not abuse the cord. Never use the cord to carry the tools or pull the plug from an outlet.**

Keep cord away from heat, oil, sharp edges, or moving parts. Replace damaged cords immediately. Damaged cords increase the risk of electric shock.

- **When operating a power tool outside, use an outdoor extension cord marked "W-A" or "W."** These cords are rated for outdoor use and reduce the risk of electric shock.

Personal Safety

- **Stay alert, watch what you are doing, and use common sense when operating a power tool. Do not use tool while tired or under the influence of drugs, alcohol, or medication.** A moment of inattention while operating power tools may result in serious personal injury.
- **Dress properly. Do not wear loose clothing or jewelry. Contain long hair. Keep your hair, clothing, and gloves away from moving parts.** Loose clothes, jewelry, or long hair can be caught in moving parts.
- **Avoid accidental starting. Be sure switch is off before plugging in.** Carrying tools with your finger on the switch or plugging in tools that have the switch on invites accidents.
- **Remove adjusting keys or wrenches before turning the tool on.** A wrench or a key that is left attached to a rotating part of the tool may result in personal injury.
- **Do not overreach. Keep proper footing and balance at all times.** Proper footing and balance enables better control of the tool in unexpected situations.
- **Use safety equipment. Always wear eye protection.** Dust mask, nonskid safety shoes, hard hat, or hearing protection must be used for appropriate conditions.

GENERAL SAFETY RULES

Tool Use and Care

- **Use clamps or other practical way to secure and support the workpiece to a stable platform.** Holding the work by hand or against your body is unstable and may lead to loss of control.
- **Do not force tool. Use the correct tool for your application.** The correct tool will do the job better and safer at the rate for which it is designed.
- **Do not use tool if switch does not turn it on or off.** Any tool that cannot be controlled with the switch is dangerous and must be repaired.
- **Disconnect the plug from the power source before making any adjustments, changing accessories, or storing the tool.** Such preventive safety measures reduce the risk of starting the tool accidentally.
- **Store idle tools out of the reach of children and other untrained persons.** Tools are dangerous in the hands of untrained users.
- **Maintain tools with care. Keep cutting tools sharp and clean.** Properly maintained tools with sharp cutting edges are less likely to bind and are easier to control.

- **Check for misalignment or binding of moving parts, breakage of parts, and any other condition that may affect the tool's operation. If damaged, have the tool serviced before using.** Many accidents are caused by poorly maintained tools.
- **Use only accessories that are recommended by the manufacturer for your model.** Accessories that may be suitable for one tool may become hazardous when used on another tool.

Service

- **Tool service must be performed only by qualified repair personnel.** Service or maintenance performed by unqualified personnel could result in a risk of injury.
- **When servicing a tool, use only identical replacement parts. Follow instructions in the Maintenance section of this manual.** Use of unauthorized parts or failure to follow Maintenance Instructions may create a risk of electric shock or injury.

SPECIFIC SAFETY RULES

Hold tool by insulated gripping surfaces when performing an operation where the cutting tool may contact hidden wiring or its cord. Contact with a "live" wire will make exposed metal parts of the tool "live" and shock the operator.

Additional Rules for Safe Operation

- **Know your power tool.** Read operator's manual carefully. Learn its applications and limitations, as well as the specific potential hazards related to this tool. Following this rule will reduce the risk of electric shock, fire, or serious injury.
- **Always wear safety glasses.** Everyday eyeglasses have only impact-resistant lenses; they are **NOT** safety glasses. Following this rule will reduce the risk of serious personal injury.
- **Protect your lungs.** Wear a face or dust mask if the operation is dusty. Following this rule will reduce the risk of serious personal injury.
- **Protect your hearing.** Wear hearing protection during extended periods of operation. Following this rule will reduce the risk of serious personal injury.
- **Inspect tool cords periodically and, if damaged, have repaired at your nearest Factory Service Center or other Authorized Service Organization.** Constantly stay aware of cord location. Following this rule will reduce the risk of electric shock or fire.
- **Check damaged parts.** Before further use of the tool, a guard or other part that is damaged should be carefully checked to determine that it will operate properly and perform its intended function. Check for alignment of moving parts, binding of moving parts, breakage of parts, mounting, and any other conditions that may affect its operation. A guard or other part that is damaged should be properly repaired or replaced by an authorized service center. Following this rule will reduce the risk of electric shock, fire, or serious injury.
- **Don't abuse cord.** Never carry the tool by the cord or yank it to disconnect it from the receptacle. Keep cord away from heat, oil, and sharp edges. Following this rule will reduce the risk of electric shock or fire.
- **Make sure your extension cord is in good condition.** When using an extension cord, be sure to use one heavy enough to carry the current your product will draw. A wire gage size (A.W.G.) of at least 16 is recommended for an extension cord 100 feet or less in length. A cord exceeding 100 feet is not recommended. If in doubt, use the next heavier gage. The smaller the gage number, the heavier the cord. An undersized cord will cause a drop in line voltage resulting in loss of power and overheating.
- **Inspect for and remove all nails from lumber before drilling.** Following this rule will reduce the risk of serious personal injury.
- **Drugs, alcohol, medication.** Do not operate tool while under the influence of drugs, alcohol, or any medication. Following this rule will reduce the risk of electric shock, fire, or serious personal injury.
- **Save these instructions.** Refer to them frequently and use them to instruct others who may use this tool. If you loan someone this tool, loan them these instructions also.





WARNING: Some dust created by power sanding, sawing, grinding, drilling, and other construction activities contains chemicals known to cause cancer, birth defects or other reproductive harm. Some examples of these chemicals are:

- lead from lead-based paints,
- crystalline silica from bricks and cement and other masonry products, and
- arsenic and chromium from chemically-treated lumber.

Your risk from these exposures varies, depending on how often you do this type of work. To reduce your exposure to these chemicals: work in a well ventilated area, and work with approved safety equipment, such as those dust masks that are specially designed to filter out microscopic particles.

SYMBOLS

Important: Some of the following symbols may be used on your tool. Please study them and learn their meaning. Proper interpretation of these symbols will allow you to operate the tool better and safer.

SYMBOL	NAME	DESIGNATION/EXPLANATION
V	Volts	Voltage
A	Amperes	Current
Hz	Hertz	Frequency (cycles per second)
W	Watt	Power
min	Minutes	Time
~	Alternating Current	Type or a characteristic of current
n_0	No Load Speed	Rotational speed, at no load
	Class II Construction	Designates Double Insulated Construction tools
.../min	Revolutions or Reciprocation Per Minute	Revolutions, strokes, surface speed, orbits etc. per minute
	Safety Alert Symbol	Indicates danger, warning or caution. It means attention!!! Your safety is involved.

The purpose of safety symbols is to attract your attention to possible dangers. The safety symbols, and the explanations with them, deserve your careful attention and understanding. The safety warnings do not by themselves eliminate any danger. The instructions or warnings they give are not substitutes for proper accident prevention measures.

SYMBOL MEANING



SAFETY ALERT SYMBOL:

Indicates danger, warning, or caution. May be used in conjunction with other symbols or pictographs.



DANGER: Failure to obey a safety warning will result in serious injury to yourself or to others. Always follow the safety precautions to reduce the risk of fire, electric shock and personal injury.



WARNING: Failure to obey a safety warning can result in serious injury to yourself or to others. Always follow the safety precautions to reduce the risk of fire, electric shock and personal injury.



CAUTION: Failure to obey a safety warning may result in property damage or personal injury to yourself or to others. Always follow the safety precautions to reduce the risk of fire, electric shock and personal injury.

NOTE: Advises you of information or instructions vital to the operation or maintenance of the equipment.

SAVE THESE INSTRUCTIONS

FEATURES

KNOW YOUR ELECTRIC DRILL

See Figure 1.

Before attempting to use your drill, familiarize yourself with all operating features and safety requirements.

Your drill has many features for making drilling operations more pleasant and enjoyable. Safety, performance, and dependability have been given top priority in the design of this drill making it easy to maintain and operate.

CAUTION: Carefully read through this entire operator's manual before using your new drill. Pay close attention to the Rules For Safe Operation, Warnings, and Cautions. If you use your drill properly and only for what it is intended, you will enjoy years of safe, reliable service.

ELECTRICAL CONNECTION

Your drill has a precision built electric motor. It should be connected to a **power supply that is 120 volts, 60 Hz, AC only (normal household current)**. Do not operate this tool on direct current (DC). A substantial voltage drop will cause a loss of power and the motor will overheat. If your drill does not operate when plugged into an outlet, double-check the power supply.

APPLICATIONS

(Use only for the purpose listed below)

- Drilling in wood.
- Drilling in ceramics, plastics, fiberglass, and laminates.
- Drilling in both hard and soft metals.
- Using driving accessories, such as driving screws with screwdriver bits.
- Mixing paints.

PRODUCT SPECIFICATIONS

Chuck Capacity	1/16 in. to 3/8 in.
Horsepower	1/2
Input	120 Volts, 60 Hz, AC
Rating	6.0 Amperes
No Load Speed ..	0-2500 RPM
Net Weight	3.875 lbs.

LEVEL AND BELT CLIP

Two convenient features provided on your drill are a level and a belt clip. The level is recessed in the motor housing on your drill. It can be used to keep drill bits level during both horizontal and vertical drilling operations. The belt clip is molded into the top of the motor housing on your drill.

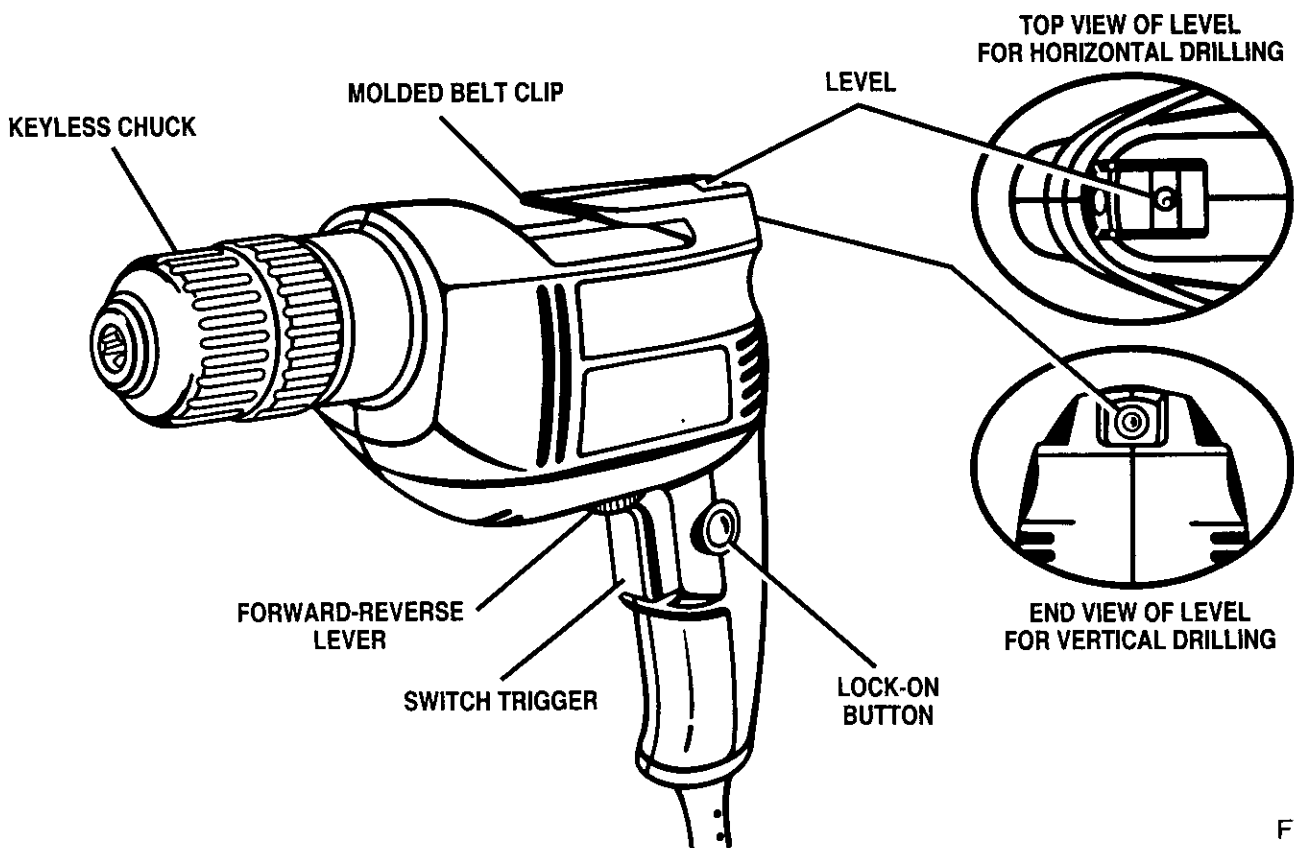

Fig. 1

WARNING: Do not allow familiarity with tools to make you careless. Remember that a careless fraction of a second is sufficient to inflict severe injury.

OPERATION

⚠ WARNING: If any parts are missing, do not operate this tool until the missing parts are replaced. Failure to do so could result in possible serious personal injury.

⚠ WARNING: Always wear safety goggles or safety glasses with side shields when operating your drill. Failure to do so could result in dust, shavings, loose particles or foreign objects being thrown into your eyes, causing possible serious injury.

SWITCH

See Figure 2.

To turn your drill **ON**, depress the switch trigger. Release switch trigger to turn your drill **OFF**.

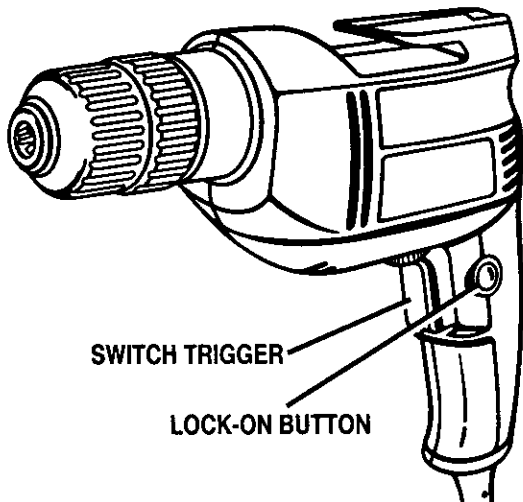

Fig. 2

LOCK-ON BUTTON

See Figure 2.

Your drill is equipped with a lock-on feature, which is convenient when continuous drilling for extended periods of time is required. To lock-on, depress the switch trigger, push in and hold the lock-on button located on the side of the handle, then release switch trigger. Release lock-on button and your drill will continue running.

To release the lock, depress the switch trigger and release.

If you have the lock-on feature engaged during use and your drill becomes disconnected from power supply, disengage the lock-on feature immediately.

KEYLESS CHUCK

See Figure 3.

Your new drill has a keyless chuck. As the name implies, you can hand tighten or release drill bit in the chuck jaws. Grasp and hold the collar of the chuck with one hand. Rotate the chuck body with your other hand. The arrows shown in figure 3 indicate which direction

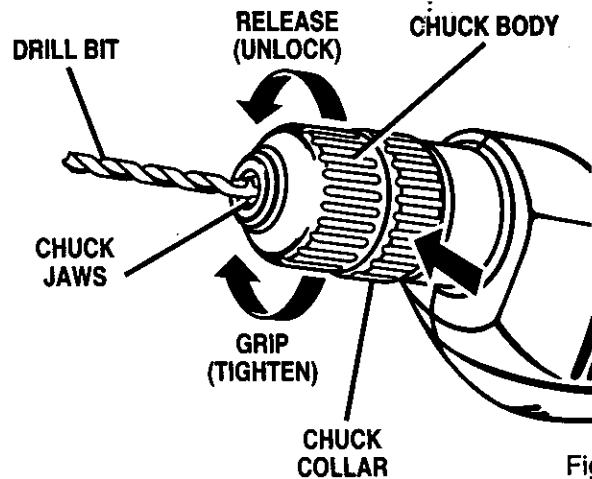

Fig. 3

to rotate the chuck body in order to **GRIP** (tighten) or **RELEASE** (unlock) the drill bit.

⚠ WARNING: Do not hold the chuck body with one hand and use the power of the drill to tighten chuck jaws on drill bit. The chuck body could slip in your hand or your hand could slip and come in contact with a rotating drill bit. This could cause an accident resulting in serious personal injury.

REVERSIBLE

See Figure 4.

Your electric drill has the feature of being reversible. The direction of chuck rotation is controlled by a lever located above the switch trigger. With your drill held in normal operating position, the direction of rotation lever should be positioned to the left of the switch for drilling. The drill direction is reversed when the lever is to the right of the switch.

The design of the switch will not permit changing the direction of rotation while the drill is running. Release the switch trigger and allow the drill to stop before changing its direction.

Note: Your drill will not run unless the switch lever is pushed fully to the left or right.

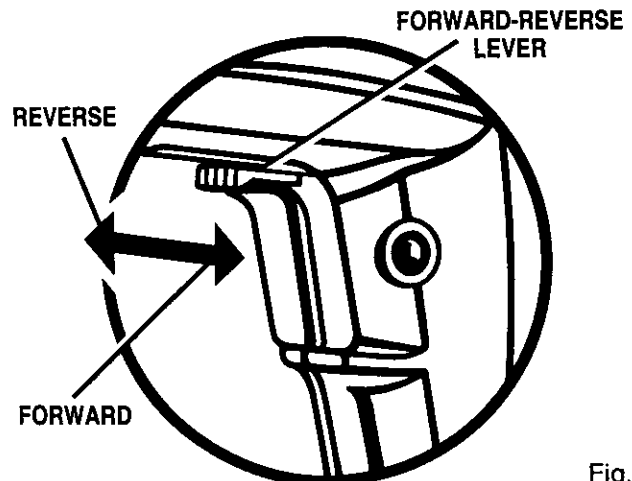

Fig. 4

OPERATION

VARIABLE SPEED

See Figure 5.

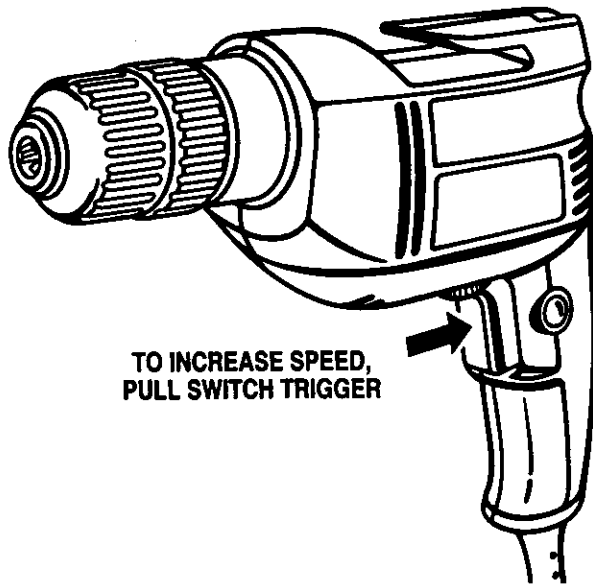

Fig. 5

Your drill has a variable speed switch designed to allow operator control of speed and torque limits. The speed and torque of your drill can be increased by depressing the switch trigger.

Note: Depress switch trigger all the way for maximum speed and torque of your drill. Depress switch trigger only part of the way for less speed and torque.

Avoid running your drill at low speeds for extended periods of time. Running at low speeds under constant usage may cause your drill to become overheated. If this occurs, cool your drill by running it without a load and at full speed.

The following guidelines may be used in determining correct speed for various applications:

- **Low speed** is ideal when minimum speed and power is required. For example, starting holes without center punching, driving screws, mixing paint, and drilling in ceramics.
- **Medium speed** is suitable for drilling hard metals, plastics, and laminates.
- **High speed** produces best results when maximum power is required. For example, drilling in wood; soft metals such as aluminum, brass, and copper, and when using driving accessories.

⚠ WARNING: Your drill should never be connected to power supply when you are assembling parts, making adjustments, installing or removing drill bits, cleaning, or when not in use. Disconnecting your drill will prevent accidental starting that could cause serious personal injury.

TO INSTALL BITS

See Figure 6.

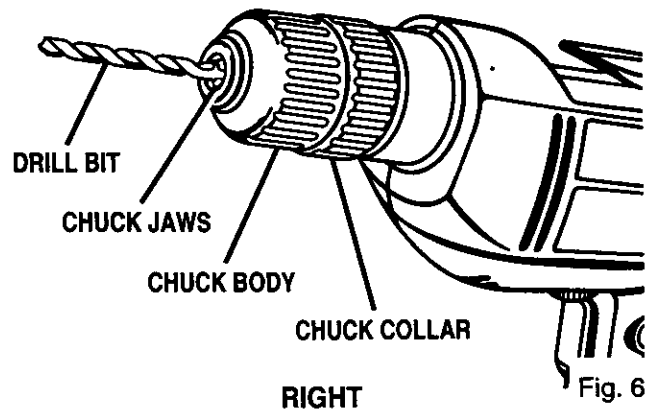

Fig. 6

- Unplug your drill.

⚠ WARNING: Failure to unplug your drill could result in accidental starting causing serious injury.

- Open or close the chuck jaws to a point where the opening is slightly larger than the drill bit you intend to use. Also, raise the front of your drill slightly to keep the drill bit from falling out of the chuck jaws.
- Insert drill bit into chuck the full length of the jaws.

⚠ WARNING: Do not insert drill bit into chuck jaws and tighten as shown in figure 7. This could cause drill bit to be thrown from your drill resulting in possible serious personal injury or damage to your chuck.

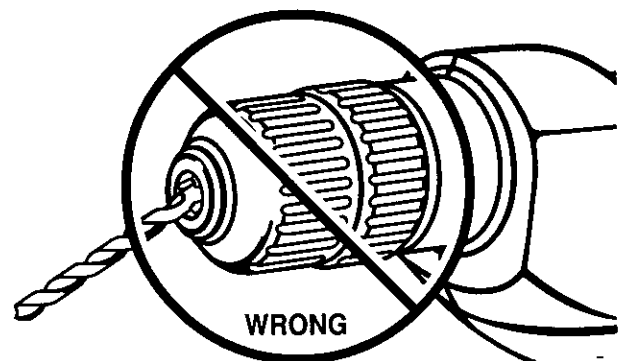

Fig. 7

- Tighten the chuck jaws on drill bit.
- To tighten: grasp and hold the collar of the chuck with one hand, while rotating the chuck body with your other hand.

Note: Rotate the chuck body in the direction of the arrow marked **GRIP** to tighten chuck jaws.

- **Do not** use a wrench to tighten or loosen the chuck jaws.

OPERATION

TO REMOVE BITS

- Unplug your drill.

⚠ WARNING: Failure to unplug your drill could result in accidental starting causing serious injury.

- Loosen the chuck jaws from drill bit.
- To loosen: grasp and hold the collar of the chuck with one hand, while rotating chuck body with your other hand.

Note: Rotate the chuck body in the direction of the arrow marked **RELEASE** to loosen chuck jaws.

- **Do not** use a wrench to tighten or loosen the chuck jaws.
- Remove drill bit from chuck jaws.

DRILLING

See Figures 8 and 9.

- Depress and release switch trigger to be sure your drill is in **OFF** position before connecting it to power supply.
- Check the direction of rotation lever for correct setting (forward or reverse). See Figure 4.
- Secure the material to be drilled in a vise or with clamps to keep it from turning as the drill bit rotates.
- Plug your drill into power supply source.
- Hold your drill firmly and place bit at point to be drilled.
- Depress the switch trigger to start your drill. Do not lock the switch **ON** for jobs where your drill may need to be stopped suddenly.
- Move the drill bit into the workpiece applying only enough pressure to keep the bit cutting. Do not force your drill or apply side pressure to elongate a hole. Let your drill and bit do the work. See Figures 8 and 9.

⚠ WARNING: Be prepared for binding or bit breakthrough. When these situations occur, drill has a tendency to grab and kick opposite to the direction of rotation and could cause loss of control when breaking through materials. If not prepared, this loss of control can result in possible serious injury.

When drilling hard, smooth surfaces use a center punch to mark the desired hole location. This will prevent the drill bit from slipping off center as the hole is started. However, the variable speed feature allows starting holes without center punching if desired. To accomplish this, operate your drill at a low speed until the hole is started.

When drilling metals use a light oil on the drill bit to keep it from overheating. The oil will prolong the life of the bit and increase the drilling action.

If the bit jams in the work piece or if your drill stalls, stop the tool immediately. Remove the bit from the work piece and determine the reason for jamming.

LEVEL DRILLING

See Figures 8 and 9.

A convenient feature provided on your drill is a level. It is recessed in the motor housing on your drill. It can be used to keep drill bits level during both horizontal and vertical drilling operations.

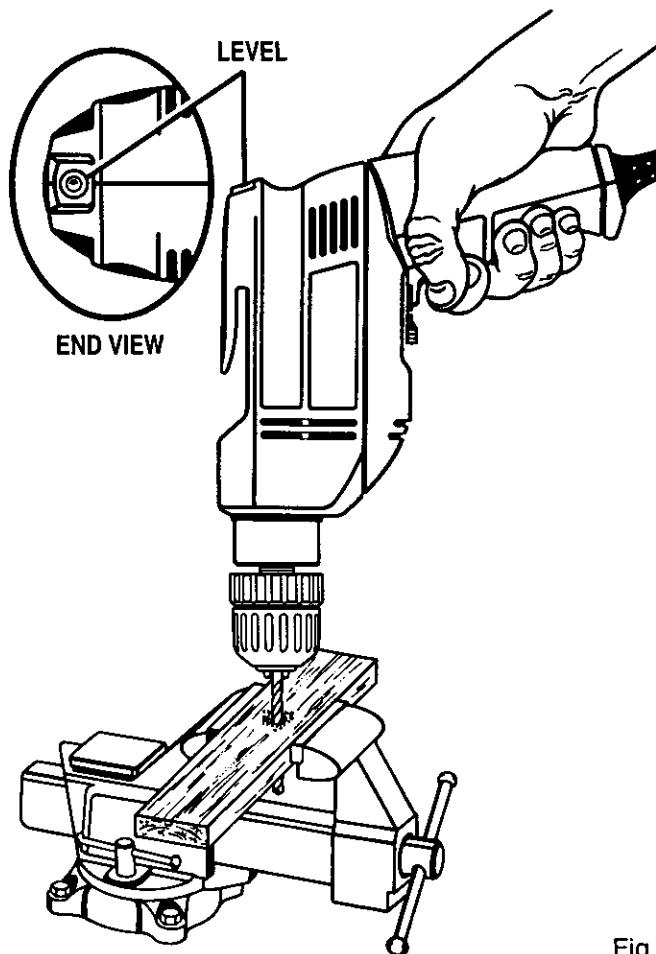

Fig. 8

OPERATION

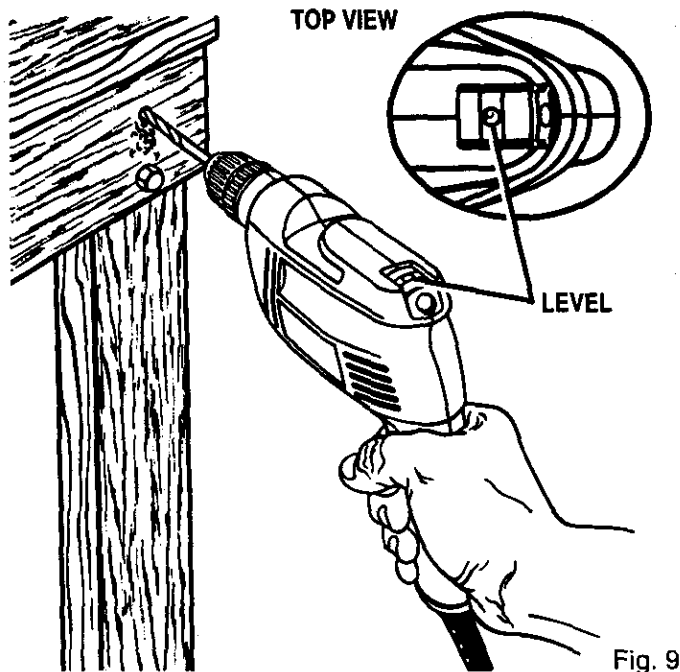

Fig. 9

CHUCK REMOVAL

See Figures 10, 11, and 12.

The chuck must be removed in order to use some accessories. To remove:

- Unplug your drill.

⚠ WARNING: Failure to unplug your drill could result in accidental starting causing serious injury.

- Insert a 8 mm (5/16 in.) or larger hex key wrench into the chuck of your drill and tighten the chuck jaws securely.
- Tap the hex key wrench sharply with a mallet in a clockwise direction. See Figure 10. This will loosen the screw in the chuck for easy removal.

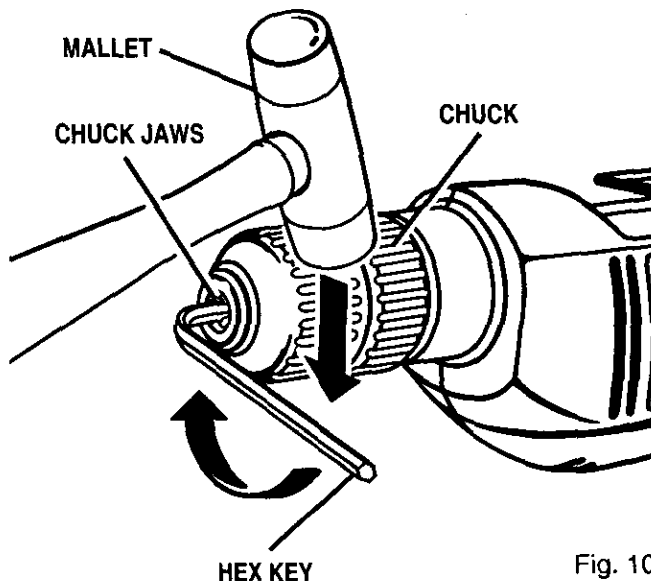

Fig. 10

- Open the chuck jaws and remove hex key wrench. Remove the chuck screw by turning it in a clockwise direction. See Figure 11.

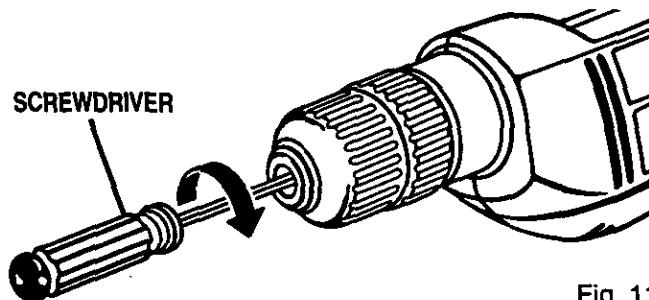

Fig. 11

Note: The chuck screw has left hand threads.

- Insert hex key wrench into chuck and tighten chuck jaws securely. Tap sharply with a mallet in a counterclockwise direction. This will loosen the chuck on the spindle. It can now be unscrewed by hand. See Figure 12.

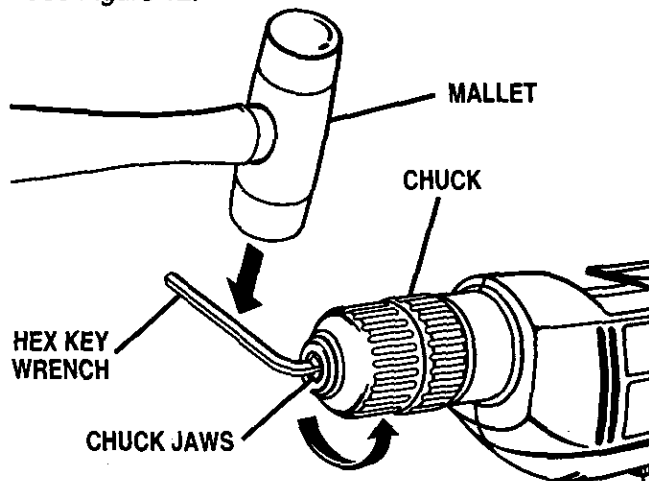

Fig. 12

The chuck may at times become loose on the spindle and develop a wobble. Also, the chuck screw may become loose causing the chuck jaws to bind and prevent them from closing. To tighten, follow these steps:

- Unplug your drill.
- ⚠ **WARNING:** Failure to unplug your drill could result in accidental starting causing serious injury.
- Insert hex key wrench into chuck and tighten chuck jaws securely. Tap hex key wrench sharply with a mallet in a clockwise direction. This will tighten the chuck on the spindle.
- Open the chuck jaws and remove the hex key wrench.
- Tighten the chuck screw.

Note: The chuck screw has left hand threads.

MAINTENANCE

GENERAL

Only the parts shown on parts list, page 13, are intended to be repaired or replaced by the customer. All other parts represent an important part of the double insulation system and should be serviced only at a Sears Service Center.

Avoid using solvents when cleaning plastic parts. Most plastics are susceptible to damage from various types of commercial solvents and may be damaged by their use. Use clean cloths to remove dirt, carbon dust, etc.

⚠ WARNING: Do not at any time let brake fluids, gasoline, petroleum-based products, penetrating oils, etc. come in contact with plastic parts. They contain chemicals that can damage, weaken or destroy plastic.

It has been found that electric tools are subject to accelerated wear and possible premature failure when they are used on fiberglass boats, sports cars, wallboard, spackling compounds, or plaster. The chips and grindings from these materials are highly abrasive to electric tool parts, such as bearings, brushes, commutators, etc. Consequently, it is not recommended that this tool be used for extended work on any fiberglass material, wallboard, spackling compounds, or plaster. During any use on these materials, it is extremely important that the tool is cleaned frequently by blowing with an air jet.

LUBRICATION

All of the bearings in this tool are lubricated with a sufficient amount of high-grade lubricant for the life of the unit under normal operating conditions. Therefore, no further lubrication is required.

⚠ WARNING: Always wear safety goggles or safety glasses with side shields during power tool operation or when blowing dust. If operation is dusty, also wear a dust mask.

DOUBLE INSULATION

Double insulation is a concept in safety in electric power tools, which eliminates the need for the usual three-wire grounded power cord. All exposed metal parts are isolated from the internal metal motor components with protecting insulation. Double insulated tools do not need to be grounded.

IMPORTANT

Servicing of a tool with double insulation requires extreme care and knowledge of the system and should be performed only by a qualified service technician. For service, we suggest you return the tool to your nearest Sears store for repair. Always use original factory replacement parts when servicing.

EXTENSION CORDS

The use of any extension cord will cause some loss of power. To keep the loss to a minimum and to prevent tool overheating, use an extension cord that is heavy enough to carry the current the tool will draw.

A wire gage size (A.W.G.) of at least 16 is recommended for an extension cord 100 feet or less in length. When working outdoors, use an extension cord that is suitable for outdoor use. The cord's jacket will be marked **WA**.

⚠ CAUTION: Keep extension cords away from the drilling area and position the cord so that it will not get caught on lumber, tools, etc., during drilling operation.

⚠ WARNING: Check extension cords before each use. If damaged replace immediately. Never use tool with a damaged cord since touching the damaged area could cause electrical shock resulting in serious injury.

Extension cords suitable for use with your drill are available at your nearest Sears Retail Store.

ACCESSORIES

The following recommended accessories are currently available at Sears retail stores.

- | | |
|---------------------------------------|--------------|
| ■ High Speed Bits (For wood or metal) | 1/2 in. Max. |
| ■ Masonry Bits | 3/4 in. Max. |
| ■ Wood Boring Bits | 1 in. Max. |
| ■ Hole Saws | 2 in. Max. |
| ■ Doweling Jig | |
| ■ Drill Stand | |
| ■ Wire Brushes, All | |

⚠ WARNING: The use of attachments or accessories not listed might be hazardous.

⚠ WARNING:



The operation of any drill can result in foreign objects being thrown into your eyes, which can result in severe eye damage. Before beginning power tool operation, always wear safety goggles or safety glasses with side shields and a full face shield when needed. We recommend Wide Vision Safety Mask for use over eyeglasses or standard safety glasses with side shields. Always wear eye protection which is marked to comply with ANSI Z87.1.

WARRANTY

FULL ONE YEAR WARRANTY ON CRAFTSMAN PROFESSIONAL ELECTRIC DRILL

If this **CRAFTSMAN** Drill fails due to a defect in material or workmanship within one year from the date of purchase, Sears will replace it, free of charge.

WARRANTY SERVICE IS AVAILABLE BY SIMPLY RETURNING THE TOOL TO THE NEAREST SEARS STORE IN THE UNITED STATES.

This warranty gives you specific legal rights, and you may also have other rights which vary from state to state.

Sears, Roebuck and Co., Dept. 817WA, Hoffman Estates, IL 60179

SAVE THESE INSTRUCTIONS

**CRAFTSMAN 3/8 in. PROFESSIONAL ELECTRIC DRILL
MODEL NO. 315.269390**

The model number will be found on a plate attached to the motor housing. Always mention the model number in all correspondence regarding your **ELECTRIC DRILL** or when ordering repair parts.

SEE BACK PAGE FOR PARTS ORDERING INSTRUCTIONS

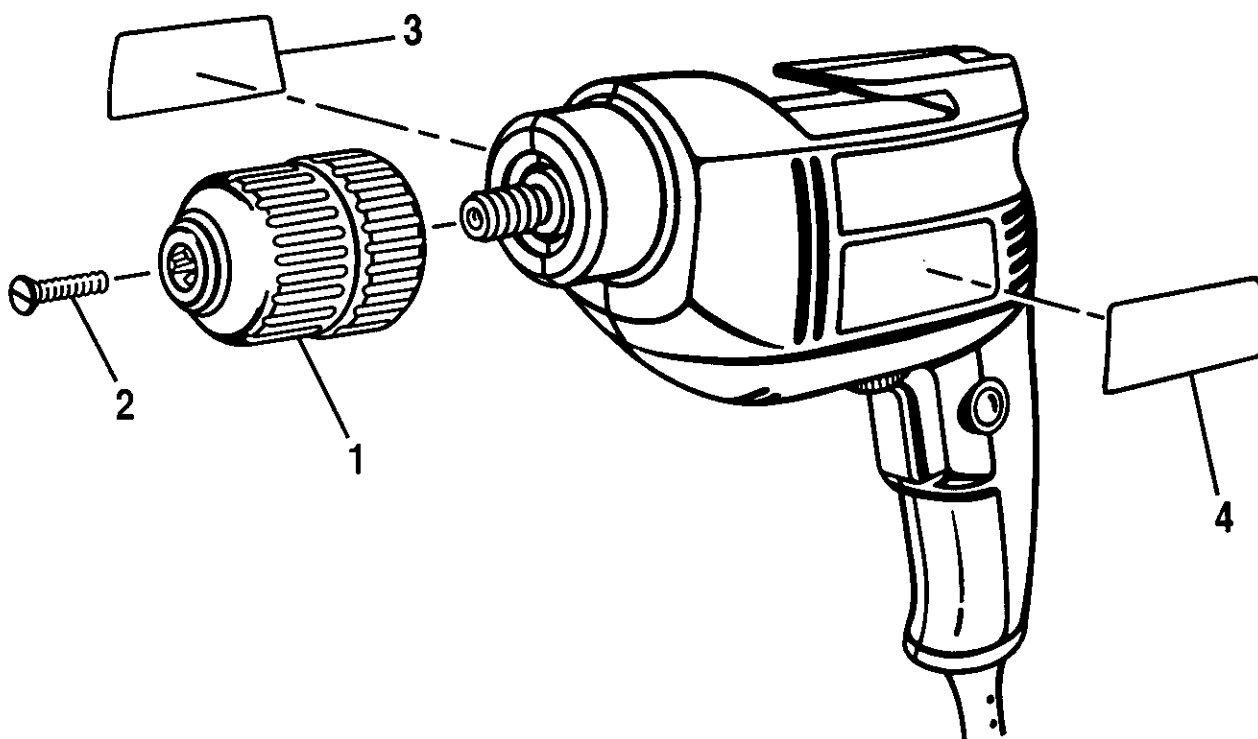

PARTS LIST

Key No.	Part No.	Description	Quan.
1	981570-002	3/8 in. Chuck	1
2	616478-003	Screw (Special)	1
3	983063-001	Data Plate	1
4	983090-001	Logo Plate	1
	972000-948	Operator's Manual	

For repair of major brand appliances **in your own home...**
no matter who made it, no matter who sold it!

1-800-4-MY-HOMESM Anytime, day or night
(1-800-469-4663)

www.sears.com

To bring in products such as vacuums, lawn equipment and electronics
for repair, call for the location of your nearest **Sears Parts & Repair Center.**

1-800-488-1222 Anytime, day or night

www.sears.com

For the replacement parts, accessories and owner's manuals
that you need to do-it-yourself, call **Sears PartsDirectSM**!

1-800-366-PART 6 a.m. – 11 p.m. CST,
(1-800-366-7278) 7 days a week

www.sears.com/partsdirect

To purchase or inquire about a Sears Service Agreement:

1-800-827-6655

7 a.m. – 5 p.m. CST, Mon. – Sat.

Para pedir servicio de reparación a domicilio,
y para ordenar piezas con entrega a domicilio:

1-888-SU-HOGARSM
(1-888-784-6427)

Au Canada pour service en français:

1-877-LE-FOYERSM
(1-877-533-6937)

