

RCA

VCR User's Guide

Changing Entertainment. Again.



VR355/VR545

Important Information

WARNING

To reduce the risk of fire or electric shock, do not expose this product to rain or moisture.

CAUTION

RISK OF ELECTRIC SHOCK. DO NOT OPEN.

To reduce the risk of electric shock, do not remove cover (or back). No user serviceable parts inside. Refer servicing to qualified service personnel.



This symbol indicates "dangerous voltage" inside the product that presents a risk of electric shock or personal injury.



This symbol indicates important instructions accompanying the product.

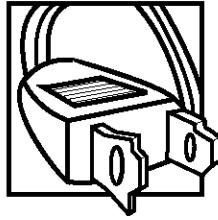

Caution: To prevent electric shock, match wide blade of plug to wide slot, fully insert.

Attention: Pour éviter les chocs électriques, introduire la lame la plus large de la fiche dans la borne correspondante de la prise et pousser jusqu'au fond.

Refer to the identification/rating label located on the back panel of your product for its proper operating voltage.

FCC Regulations state that unauthorized changes or modifications to this equipment may void the user's authority to operate it.

Cable TV Installer: This reminder is provided to call your attention to Article 820-40 of the National Electrical Code (Section 54 of the Canadian Electrical Code, Part 1) which provides guidelines for proper grounding and, in particular, specifies that the cable ground shall be connected to the grounding system of the building as close to the point of cable entry as practical.

Product Registration

Please fill out the product registration card and return it immediately. Returning the card allows us to contact you if needed.

Keep your sales receipt to obtain warranty parts and service and for proof of purchase. Attach it here and record the serial and model numbers in case you need them. The numbers are located on the back of the product.

Model No. **VR355/VR545** _____

Serial No. _____

Purchase Date: _____

Dealer/Address/Phone: _____

Key Features Overview

Your VCR is equipped with features that will add to your recording experience. The following information summarizes a few of these features. Chapter 3 provides more information about the rest of the VCR's features and how to use them.



Unified Remote Control

Description: The VCR's remote control can operate most RCA, GE, and Proscan TVs with no additional steps.

Requirements: Point the remote at the active device to see if it can be operated.

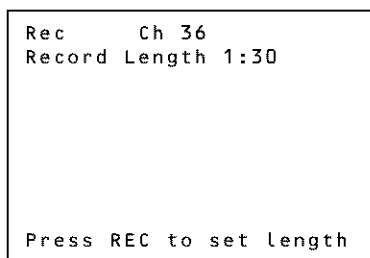

Express Recording (XPR)

Description: XPR quickly records the remaining portion of a program in progress. XPR is a great way to capture the end of a sporting event that has run into overtime or a live broadcast that runs long.

Requirements: The Record button on the VCR front panel or remote control.

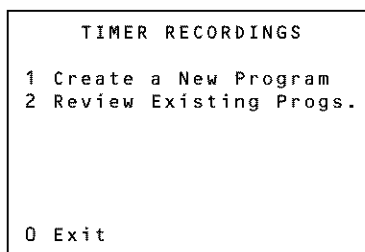

Timer Recordings

Description: Your VCR allows you to program up to eight different future broadcasts to be recorded. You can catch a one-time, daily, or weekly broadcast to record.

Requirements: The VCR's clock must be set correctly. A tape with its safety tab in place and enough tape to record a program must be inserted into the VCR. For a cable box or satellite receiver, turn it on and tune it to the channel you want to record before the recording is to begin.

ShowSaver™ Memory Protection

Description: Set timer programs are stored indefinitely using the VCR's permanent memory so you'll never have to worry about losing your programs due to an extended power outage.

Requirements: Store a daily or weekly timer program in the VCR's memory.



Pro-Tect Plus™ Locking

Description: Locks the VCR so that buttons on the front panel and remote control won't operate the VCR. This feature protects timer programs from frustrating accidents such as being left on at the time of recording.

Requirements: Lock the VCR by pressing and holding the ON•OFF button on the remote control for six seconds until *SAFE* appears on the front panel display. Unlock the VCR by pressing and holding the ON•OFF button on the remote control, again for six seconds. *SAFE* disappears from the front panel display when the lock on the system has been released.

SQPB S-VHS Quasi Playback

Description: Your VCR will be able to play back tapes recorded in S-VHS or S-VHS-ET mode (in VHS quality).

Requirements: Insert a tape recorded in S-VHS or S-VHS-ET mode and pressing the PLAY button on the remote control or PLAY•PAUSE on the VCR.

Table of Contents

Product Registration	i
Introduction	1
Key Features Overview	1
Connections & Setup	5
Things to Consider Before Connecting Components	6
Cable Considerations	6
Choose Your Connection	7
Using the RF Coaxial Cable to Connect the VCR to a TV	7
TV + VCR	8
TV + VCR + Satellite Receiver	9
TV + VCR + Cable Box	10
Set the VCR's CH 3/4 Switch	11
Plug in the VCR	11
Put Batteries in the Remote Control	11
Turn on the TV and VCR	11
Tune the TV	11
Using the Remote Control to	
Navigate On-Screen Menus	12
Complete the QuickSet Guide	12
Accessing Menus	12
VCR Basics	13
Playing a Tape	13
Automatic Rewind	13
Tape Eject	13
Recording	13
Check the Safety Tab	13
Using the VCR's Menu System	15
Using On-Screen Menus to Set Up Features	16
Language	16
Cable Box Setup	16
VCR Channels List	17
Auto Channel Searching	17
Changing the Signal Type	18
Adding or Removing Channels	18
Time and Date	19
Auto Clock Set Feature	19
To Turn Auto Clock Set ON	19
Setting the Time Zone	19
Setting Daylight-Saving Time	20
Setting Time and Date Manually	20
Additional Set Up Features in the Preferences Menu	20
Remote VCR1/VCR2 Option	21
Auto Play	21
Auto TV/VCR	21
EnergySaver	22
Front Panel Brightness (VCR Display)	22
Tape Speed	22
Set Auto Repeat	23

Table of Contents

Using the Remote Control	25
Using the Remote Control	26
Buttons of the Remote Control	26
Using the INPUT Button	27
Operating a Television with the VCR's Remote Control	28
Using the VCR's Features	29
Recording Features	30
Express Recording (XPR)	30
Timer Recording	31
Stopping a Timer Recording	31
Reviewing and Clearing Programs	31
Copying and Editing Tapes Using Two VCRs	32
Picture Search Options	32
Forward and Reverse Search	32
Slow Motion	33
Frame Advance	33
Index Search	33
Zero Search	34
Pro-Tect Plus™ Locking Feature	34
Tracking	35
Time Counter	35
On-Screen Displays	36
Other Information	37
Troubleshooting	38
General Problems	38
Playback Problems	39
Recording Problems	41
Front Panel	42
Display Panel	43
Back Panel	44
Cleaning the VCR	45
Specifications (VR355)	45
Specifications (VR545)	45
How to Find Your TV's Video Input Channel	46
Advanced Connection	47
TV + VCR + Satellite Receiver	47
Warranty	48
Glossary	49
Index	50

Connections & Setup

Chapter Overview:

- Things to Consider Before Connecting
- Choosing Your Connection
- Making Connections
- Why You Should Connect with Audio/Video Jacks
- Navigating On-Screen Menus
- Completing the QuickSet™ Guide
- Basic Recording

Changing Entertainment. Again.



Things to Consider Before Connecting Components

Protect Components From Power Surges

- Connect all components before plugging any power cords into the wall outlet.
- Always turn off the TV and other components before you connect or disconnect any cables.

Position Cables to Avoid Audio Hum or Interference

- Insert all cable plugs firmly into their jacks.
- Place any Audio/Video (A/V) cables to the side(s) of the TV's back panel instead of straight down the back after connecting components.
- Try not to coil any twin-lead cables and keep them away from all A/V cables as much as possible.
- Make sure all antennas and cables are properly grounded. Refer to the *Safety Tips* sheet packed with your unit for detailed information.

Protect Components From Overheating

- Never block ventilation slots in any component. Arrange the components so that air can circulate freely.
- Do not stack components.
- Allow adequate ventilation when placing components in a stand.
- Place an amplifier or satellite receiver on the top shelf of a stand so heated air rising from it will not flow around other components.

Cable Considerations

The RF coaxial cable supplied with your VCR carries both sound and picture information. This is the cable used in all connection diagrams illustrated in this chapter.

If your TV has A/V input jacks, you should use A/V cables (not supplied) to connect the VCR to the TV. A/V cables provide better picture and sound quality than an RF coaxial cable. If you would like to hook up your VCR using A/V cables, refer to the *Advanced Connection* information on page 47 in the *Other Information* chapter of the manual.



RF Coaxial Cable

Using the RF Coaxial Cable to Connect the VCR to a TV







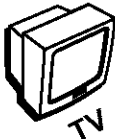

This graphic shows the RF coaxial cable supplied with your VCR. This will be the cable used for the basic connections represented in this chapter.

Notes: To hear stereo sound, you will need to purchase Audio/Video (A/V) cables (not provided) and connect the VCR to the TV. A/V jacks and cables also provide a superior image and sound quality. For details about using this advanced setup, see the instructions on page 47.

Using A/V jacks to connect the VCR to the TV requires tuning to the TV's Video Line Input to see the VCR's picture. For more information about finding your TV's Video Line Input, see page 46.

Choose Your Connection

There are several ways to hook up your VCR depending on the components connected. Please use the following chart to determine which connection is best for you and proceed to the appropriate page.

Components	Connection Title	Go To
 	TV + VCR	page 8
  	TV + VCR + Satellite Receiver	page 9
  	TV + VCR + Cable Box	page 10

Connections & Setup

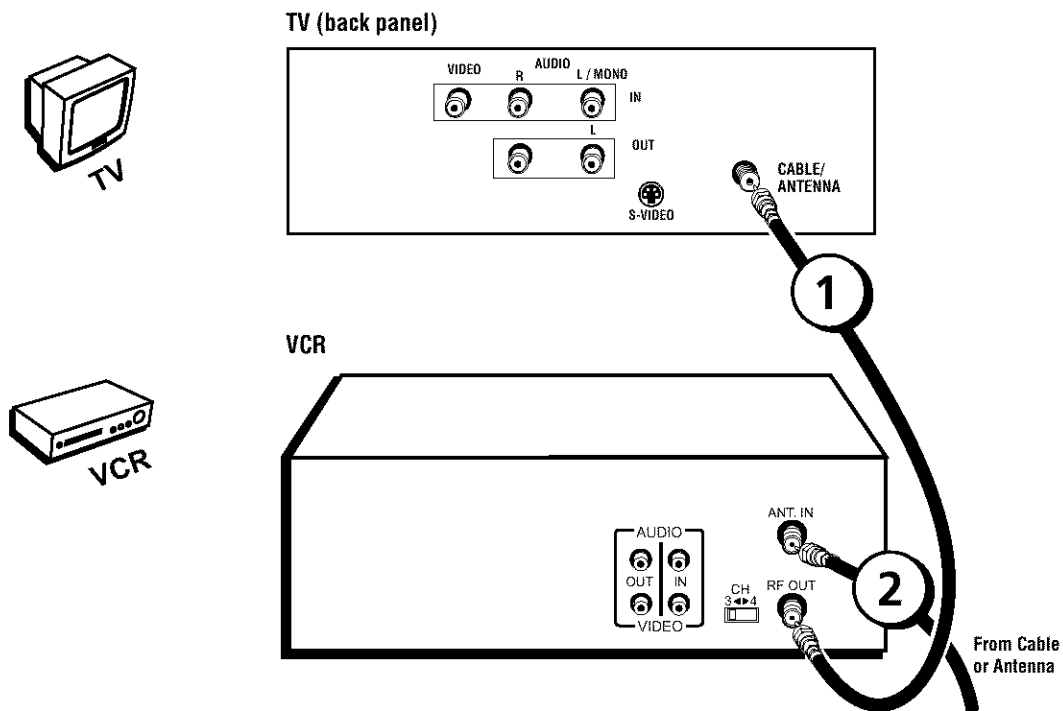

TV + VCR

Note: Your television back panel may not look exactly like the model shown here.

1. Connect the VCR to the TV

Connect one end of the supplied RF coaxial cable to the RF OUT jack on the back of the VCR and the other end to the TV's Antenna IN jack.

2. Connect the antenna/cable feed to the VCR

Connect the cable or antenna RF coaxial cable to the ANT. IN jack on your VCR.

Note: Flip the CH 3/4 switch on the back of the VCR to the channel that is *not* used in your area. This will be the channel that the TV must be tuned to in order to see the VCR's picture.

Go To Page 11

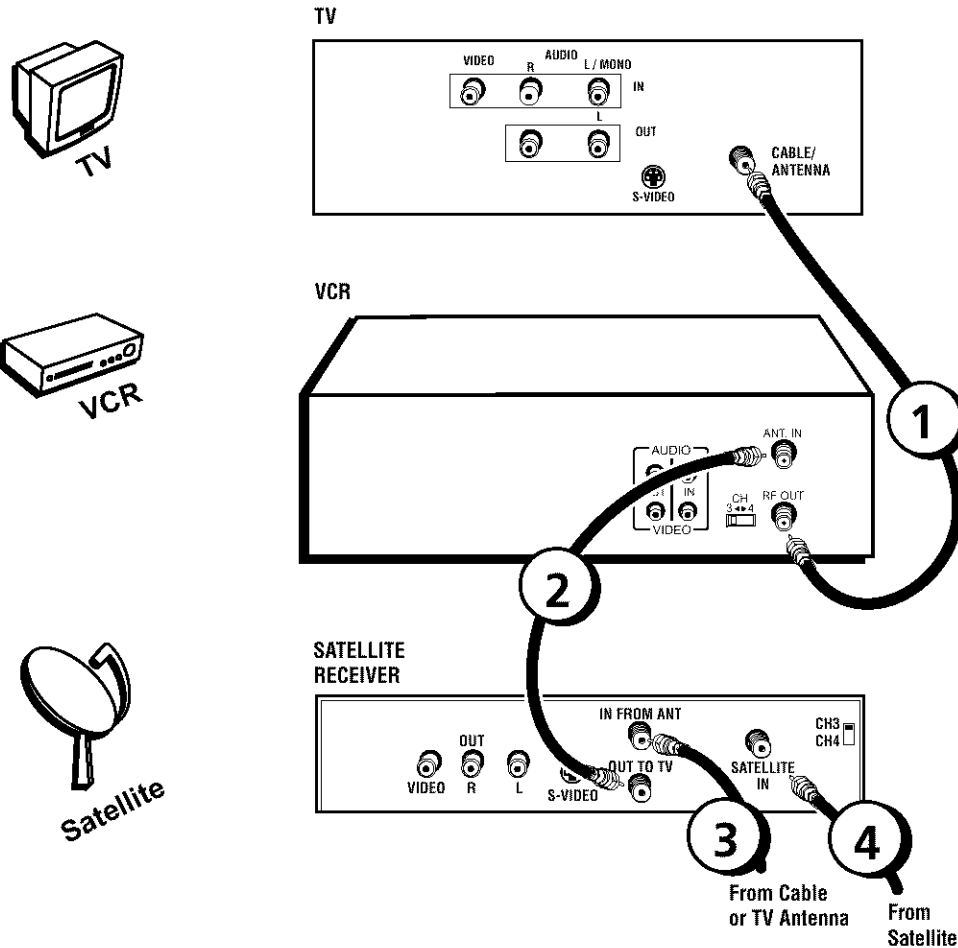

TV + VCR + Satellite Receiver

Note: Your television and/or satellite receiver back panels may not look exactly like the models shown here.

1. Connect the VCR to the TV

Connect one end of the supplied RF coaxial cable to the VCR's RF OUT jack and the other end to the TV's antenna input jack.

2. Connect satellite receiver to the VCR

Connect an RF coaxial cable to the RF OUT jack on the cable box and to the CABLE/ANTENNA input jack on the TV.

3. Connect the antenna to your satellite receiver

If necessary, connect an antenna or cable box RF coaxial cable (not included) to the antenna input jack on the satellite receiver.

4. Connect the satellite feed to the satellite receiver

Connect the satellite receiver's RF coaxial cable feed (not included) to the satellite input jack on the satellite receiver.

Go To Page 11

Connections & Setup

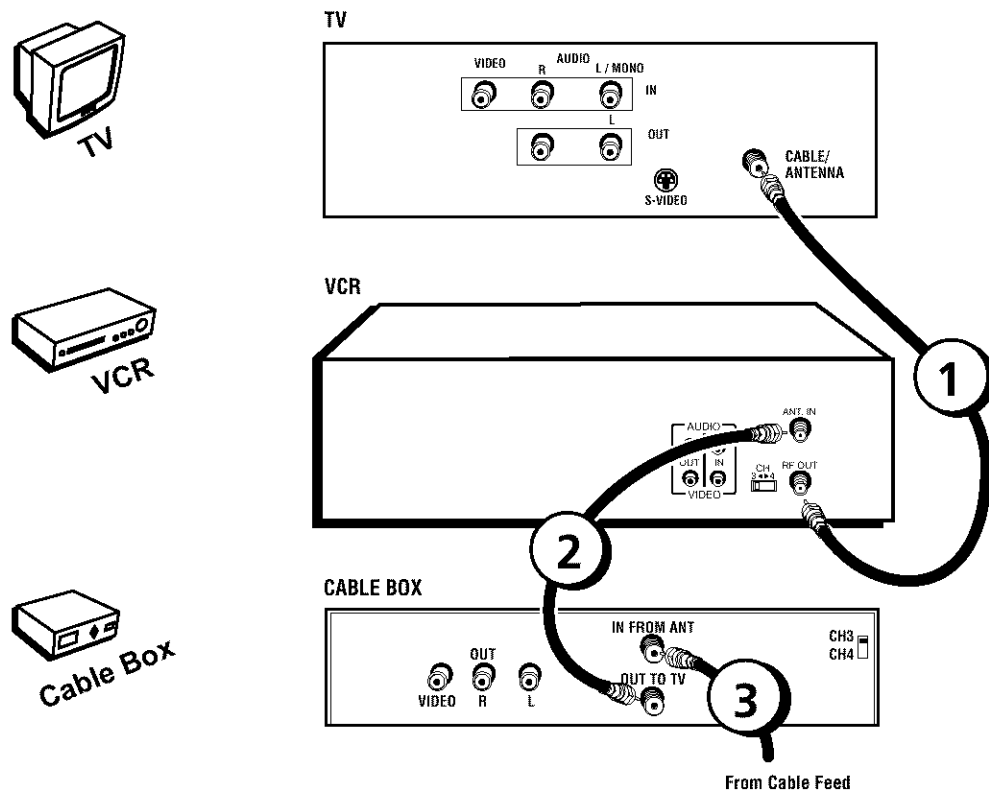

TV + VCR + Cable Box

Note: Your television and/or cable box back panels may not look exactly like the models shown here.

1. Connect the VCR to the TV

Connect one end of the supplied RF coaxial cable to the RF OUT jack on the back of the VCR and the other end to the TV's Antenna IN jack.

2. Connect the cable box to the VCR

Connect one end of a second RF coaxial cable (not included) to the cable box's TV output jack and the other end to the ANT. IN jack on the VCR.

3. Connect the cable feed to your cable box

Connect the RF coaxial cable feed (not included) to the antenna input jack on the cable box.

Go To Page 11

Set the VCR's CH 3/4 Switch

The CH 3/4 switch on back of the VCR determines what channel the TV must be tuned to see the VCR's image. Choose whichever channel is not used locally in your area.

Note: If you connected components using A/V jacks and cables, the VCR's signal must be viewed using the TV's Video Line Input. To find the Video Line Input, refer to the manual that came with the TV or see *How to Find Your TV's Video Line Input* on page 46 in the *Other Information* section of this manual.

Plug in the VCR

Your VCR's power cord has a plastic band strung through the blades. **Remove the plastic band before plugging the cord into the power outlet.** To remove the band, cut with a pair of scissors and pull it free of the blades. Once the plastic is removed, match the wide blade of the power cord to the wide slot in the AC outlet. Be sure to insert the plug completely.

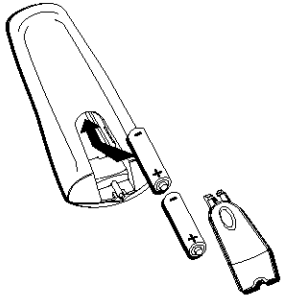

Put Batteries in the Remote Control

1. Remove the battery compartment cover on the remote control.
2. Insert new batteries matching the polarities (+ and -) on the batteries with the diagram in the battery compartment.
3. Put the battery compartment cover back on the remote.

Turn on the TV and VCR

Turn on the TV and press the VCR button on the remote control to turn it on.

Note: If you have an RCA, GE, or Proscan TV, your VCR's remote control may be able to operate it without any additional steps. Press the TV button on the remote control and then the ON•OFF button. If neither one turns on the TV, it cannot be operated by the remote control.

Tune the TV

Tune the TV to the VCR viewing channel. The VCR viewing channel is channel 3, 4, or the TV's video line input.

- If you connect your VCR using RF coaxial cable only, turn the TV to channel 3 or 4 (whichever was set on the CH 3/4 switch).
- If you connected the VCR using A/V jacks and cables, select the TV's video line input. For more information see *How to Find the TV's Video Line Input* on page 46 in the *Other Information* section of this manual.

Using the Remote Control to Navigate On-Screen Menus

The technical term is “Navigation” – how you move through the on-screen menus. The theory is the same for all the menu screens; press the corresponding number button on the remote control to select the desired on-screen menu choice.

Note: Selecting a menu item can take you to another menu, activate a choice, or activate a data entry field (such as the hour field in the Set Time menu).

Complete the QuickSet Guide

The menu system in your VCR allows you to customize your preferences as well as use all the VCR’s features. To help you use the VCR as quickly as possible, there is an initial QuickSet Guide that walks you through several important setup steps at one time.

The first time you turn on the VCR, you will be able to set up available channels, time and date information, and more. The first menu you will see asks which language you prefer to have the on-screen menus appear in.

```
Select a language.  
Seleccione un idioma.  
Choisissez une langue.  
  
1 English  
2 Español  
3 Français
```

Note: With numbered menu choices, press the corresponding number button on the remote control to select it. In the case of the language menu, press 1 for English, 2 for Español (Spanish), or 3 for Français (French).

The remaining menus throughout the setup will appear in the language chosen. Just follow the step-by-step procedures until the QuickSet Guide is complete.

Accessing Menus

The series of preferences that are set in the QuickSet Guide can also be handled individually using the VCR’s on-screen menu system. There are other settings not covered in the initial setup that are also handled using the on-screen menus.

For example, if you decide to run the QuickSet Guide again, you can access the *Setup* menu by pressing the remote control’s MENU button. Once the *Main Menu* is displayed, press the 4 button to choose *Setup*. From there, you can start the QuickSet Guide from the beginning.

All on-screen menus are accessed the same way, starting in the *Main Menu* which is displayed by pressing the remote control’s MENU button.

Note: See Chapter Two, *Using On-Screen Menus*, for details about changing the VCR’s individual settings.

```
VCR MAIN MENU  
  
1 Timer Recordings  
2 Time  
3 Channels  
4 Setup  
5 Preferences  
6 Language  
  
0 Exit
```

All of the VCR’s menus are accessed through the Main Menu. Press the remote control’s MENU button to start.

VCR Basics

Once your initial settings are complete, you can begin using your VCR. In order to begin, you must first understand some basic concepts.

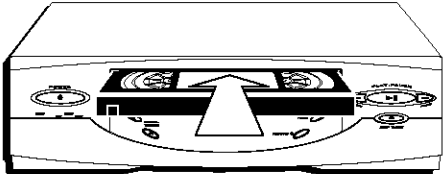

Automatic Tracking

The VCR has automatic tracking which adjusts the picture when playing back a tape recorded on another VCR. To adjust tracking manually, use the TRACKING +/- buttons on the remote control.

Playing a Tape

1. Tune the TV to your VCR viewing channel (03, 04, or the video line input).
2. Insert a tape in the VCR.

If the Auto Play feature is set to ON, the tape automatically begins playback (if the safety tab on the tape is removed).

- Press FWD or REV (FORWARD or REVERSE on the remote control) to cue the tape at the desired starting position.
- Press PLAY (if necessary) to begin tape play.
- Press PAUSE for stop action.
- Press TRACKING up or down (TRACKING + or – on the remote control) to remove any streaks from the picture, if necessary.
- Press STOP to stop playback.

Automatic Rewind

The VCR automatically rewinds the tape if it reaches the end of the tape during playback. If the tape has the safety tab removed, you can press the ON•OFF button to turn off the VCR once finished.

Tape Eject

Press the EJECT button on the VCR when stopped to eject the tape. You can also press and hold the remote control's STOP button for three seconds.

Recording

To Capture Programming with Basic Recording Methods:

1. Set the tape speed by pressing the SPEED button on the remote control (see *Tape Speed* on page 22 for information about recording speeds).
2. Press the RECORD button to begin recording.
3. Press the STOP button to halt recording.

If you just want to pause the recording for a short time (like during a commercial), press PAUSE instead of STOP.



Safety Tab

Check the Safety Tab

No matter which recording option you use, make sure there is a tape in the VCR with its safety tab in place. You cannot record on a tape with its safety tab removed. If the safety tab is removed and you want to record, simply cover the hole with adhesive tape.

This page left blank intentionally

Using the VCR's Menu System

Chapter Overview:

- Setting Up the VCR's Preferences
- Using On-Screen Menus
- Cable Box Setup
- Setting Time and Date
- Setting VCR Preferences

Changing Entertainment. Again.



Using On-Screen Menus to Set Up Features

You set up many of the VCR's features by using the menu system as discussed in the previous section. Each feature that appears in the QuickSet Guide is explained in this section as well as a few other features you should set up to get the most out of your VCR.

Note: Not all the VCR screens are shown in this manual when explaining the features.

Language

Selecting your preferred language determines how the on-screen displays will appear. To change the language:

1. Press MENU to display the *VCR MAIN MENU*.
2. Press the 6 button to select *LANGUAGE*.
3. Select English, Spanish (Español), or French (Français).

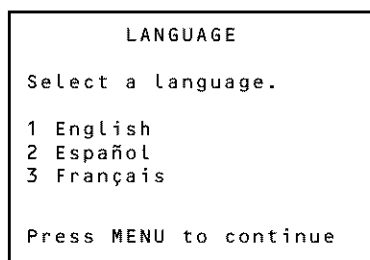

Is Something Missing?

These instructions will not show all of the step-by-step on-screen menus. Make sure to follow the instructions completely to get to the menus being discussed.

Cable Box Setup

This set up applies **only** when all channels are received through a cable box. In this case, the VCR will automatically enter the channel used to view cable box programming. Your VCR will use this channel for all future timer recordings.

1. Press MENU to display the *VCR MAIN MENU*.
2. Press 3 to display the *CHANNELS* menu.
3. Press 4 to display the *CABLE BOX SETUP* menu.

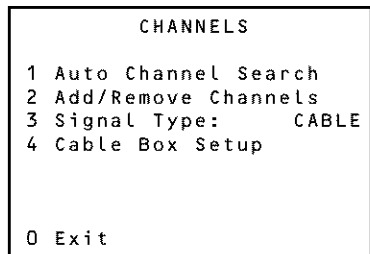

```
CABLE BOX SETUP
Do you use your cable
box to receive ALL
channels or only SOME
channels?

1 ALL channels
2 Only SOME channels
3 Cancel setup
```

```
CABLE BOX SETUP
On what channel does
the VCR receive signals
from the cable box?
(usually 3, 4, or Video)

--

Enter 01-13 or INPUT
Press MENU to cancel
```

4. Select one of the three choices. If "ALL Channels" is selected, enter the output channel of the cable box (usually 03 or 04), or if A/V jacks connect the VCR to the TV, press the INPUT button on the VCR's remote control.
5. Once you complete the setup, the VCR confirms that it will now receive all signals on the designated channel.

VCR Channels List

Your VCR may come with a list of channels preset at the factory. Even though it may come with such a list, you may want to add or delete certain channels.

Note: If you use a cable box to view *all channels*, this step is not necessary.

Auto Channel Searching

Note: Use Auto Channel Search to place all available channels in memory.

If you ever change cable or antenna signals, you may need to run the Auto Channel Search feature again.

1. Press the MENU button to display the *VCR MAIN MENU*.
2. Press 3 to select *Channels*.
3. Press 1 to select *Auto Channel Search*.
4. Select one of the three options:

```
AUTO CHANNEL SEARCH
What type of signal
are you using?

1 Cable TV
2 Antenna
3 Detect Automatically

0 Cancel
```

Cable TV searches for cable stations.

Antenna searches for local broadcast stations.

Detect Automatically decides which input to use for you.

Notes: With *Detect Automatically*, a strong cable or antenna signal in your area may cause channels to be detected inaccurately. If this should happen, manually select the input signal for the system you have.

The VCR begins scanning for channels available in the area (taking about one-to-two minutes). When scanning is complete, the VCR tunes to the lowest channel available. After completing Auto Channel Search, pressing the remote control's CHAN + or - buttons should only select active channels.

Changing the Signal Type

This feature is useful if your cable signal goes out; it allows you to switch to a regular antenna for alternate television reception.

1. Press the MENU button to display the *VCR MAIN MENU*.
2. Press the 3 button to choose *Channels*.
3. Press 3 to choose between *Signal Type: Cable* and *Antenna*. When finished, press 0 to exit back to the Main Menu and 0 again to exit to normal viewing.

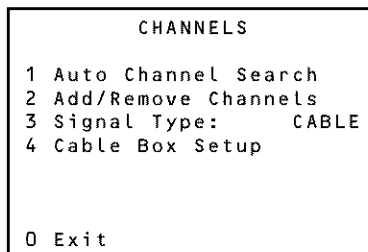

Adding or Removing Channels

You might want to add or remove channels after using Auto Channel Search, especially if there are weak signals or channels with content you don't care for.

1. Press the MENU button to display the *VCR MAIN MENU*.
2. Press 4 to choose *Channels*.
3. Press 2 to choose *Add/Remove Channels*. To go to the channel you want to add or remove, use the remote control's CHANNEL + or - buttons or enter a specific channel number using the number buttons.

Once the desired channel is displayed, the on-screen menu will tell you if the channel is currently in the VCR's viewing list. Press the CLEAR button to remove a channel from the available channels list or press the INFO button to add it.

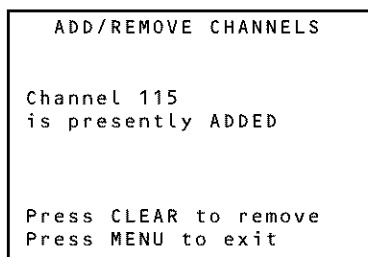

4. Once finished adding/deleting channels, press the MENU button to exit out of the menus.

Note: To view active channels, use the remote control's CHANNEL + and - buttons. You can also access channels not available in the active channel list by using the remote control's number buttons to enter the specific channel number.

Time and Date

Your VCR gives you two ways to set the time and date; manually or by using the Auto Clock Set feature. Using Auto Clock Set enables the time to be updated each time the VCR is turned off by using time and date information carried in certain broadcast signals.

Auto Clock Set Feature

The Auto Clock Set feature is set to *ON* by default at the factory. In the *ON* setting, the VCR looks for a channel carrying time data and updates the clock automatically. In order for Auto Clock Set to work properly though, certain steps must first be completed such as Auto Channel Search, setting the time zone, and setting the Daylight-Saving feature.

Notes: Auto Clock Set is available only in limited areas.

You must set available channels, time zone, and Daylight-Saving settings for Auto Clock Set to work.

When using Auto Clock Set with a cable box, the VCR will not reset the clock after a power outage unless the cable box is tuned to the channel carrying time data.

If the time does not automatically set after trying for ten minutes, manually set the time and date information using the *TIME* menu (see the next page for information on manually setting time and date information).

To Turn Auto Clock Set ON

Note: make sure that available channels, time zone, and Daylight-Saving features are set before turning on Auto Clock Set.

1. Press MENU to display the *VCR MAIN MENU*.
2. Press 2 to choose *Time*.
3. Press the 2 button repeatedly to toggle between *Auto Clock Set ON* and *OFF*.

```
TIME
1 Set Time and Date
2 Auto Clock Set:  ON
3 Set Time Zone
4 Set Daylight Savings

Time Data was found
on channel 20.

0 Exit
```

Setting the Time Zone

1. Press MENU to display the *VCR MAIN MENU*.
2. Press 2 to choose *Time*.
3. Press 3 to chose *Set Time Zone*.
4. Select your time zone by pressing the corresponding number button.

If you select *Automatic* for your time zone, the VCR sets the clock using the first time information it finds. If the time set is not correct, select another time zone or set the time and date through the menu system.

```
SET TIME ZONE
What is your Time Zone?
1 Eastern
2 Central
3 Mountain
4 Pacific
5 Alaska
6 Hawaii
7 Automatic
Press MENU to continue
```

Setting Daylight-Saving Time

1. Press MENU to display the *VCR MAIN MENU*.
2. Press 2 to choose *Time*.
3. Press 4 to choose *Set Daylight Saving*.
4. Select the appropriate option.

```
SET DAYLIGHT SAVING
Does your area observe
Daylight Saving Time
from April to October?

1 Yes, DST is observed
2 No
3 Automatic
Press MENU to continue
```

Notes: DST stands for Daylight-Saving Time.

If you choose *Automatic* for the time zone, the VCR sets the clock using any DST information broadcast in the channel's signal.

Displaying Time and Date

Pressing the *INFO* button on the remote control or VCR displays the time and date on screen temporarily.

```
SET TIME AND DATE

Time --:--
      (hh:mm)

Date --/--/--

Press MENU to cancel
```

Setting Time and Date Manually

If Auto Clock Set was unsuccessful, set the time and date manually in the *TIME* menu. Auto Clock Set is automatically turned off when time and date information is set this way.

1. Press MENU to display the *VCR MAIN MENU*.
2. Press 2 to choose *Time*.
3. Press 1 to choose *Set Time and Date*.
4. Enter the data using the number buttons. Press 0 before single-digit numbers and follow the on-screen directions to exit the menus.

```
PREFERENCES
1 Remote Control: VCR1
2 Auto Play:      ON
3 Auto TV/VCR:   ON
4 EnergySaver:   2:00
5 Front Panel:   BRIGHT
6 Tape Speed:    SLP
7 Set Auto Repeat

0 Exit
```

The *PREFERENCES* menu allows changes to be made to a variety of different VCR features.

Additional Set Up Features in the Preferences Menu

Note: The features described on the following pages are all accessed through the *PREFERENCES* menu.

To Access the *PREFERENCES* menu:

1. Press MENU to display the *VCR MAIN MENU*.
2. Press 5 to select *Preferences*.

You are now ready to select an item from the *PREFERENCES* menu to set up.

Remote VCR1/VCR2 Option

Some universal remote controls have buttons labeled VCR1 and VCR2. These remotes can operate up to two VCRs. If you have a universal remote control with this ability, your RCA VCR can be controlled with either the VCR1 or VCR2 button. See the documentation that came with your universal remote control for details about programming it to control your RCA VCR.

In the Preferences menu, press 1 to select the Remote Control feature. Then press the VCR2 button on your universal remote control to change the setting.

The VCR will only respond to the universal remote control's VCR2 button. To change the remote control setting back to VCR1, display the PREFERENCES menu, press 1, and then press the VCR1 button on the universal remote control.

Note: Remember you must press VCR1 or VCR2 on a universal remote control (not included)—whichever is selected in the menu—before the remote will operate the VCR.

Auto Play

With Auto Play turned ON (the factory default setting), the VCR automatically starts playback when you insert a tape with its safety tab removed.

To Access Auto Play:

1. In the *PREFERENCES* menu, press 2 repeatedly to switch between *Auto Play: ON* and *OFF*.
 - Select *ON* if you want a tape with its safety tab removed to start playing automatically when inserted.
 - Select *OFF* if you *do not* want a tape with its safety tab removed to start playing automatically.

Auto TV/VCR

To control whether the VCR's TV/VCR setting changes automatically to VCR-viewing mode when turned on, use the Auto TV/VCR setting.

To Access Auto TV/VCR:

1. In the *PREFERENCES* menu, press 3 to repeatedly to toggle between *Auto TV/VCR: ON* and *OFF*.

Note: Pressing the TV•VCR button on the remote control will switch between VCR and TV-viewing modes. When in VCR-viewing mode, VCR is displayed on the front panel. The VCR indicator turns off when in TV-viewing mode.

- Select *ON* to switch VCR-viewing mode on automatically when the power is turned on. The VCR must be connected to the TV using the supplied RF coaxial cable.
- Select *OFF* to remain in the TV-viewing mode when the VCR is initially turned on. Leaving Auto TV/VCR off is useful if you use A/V cables to connect the VCR to the TV and you watch the VCR's picture using the TV's video line input. This way, the antenna/cable signal will not be interrupted by the VCR.

Using On-Screen Menus

PREFERENCES	
1	Remote Control: VCR1
2	Auto Play: ON
3	Auto TV/VCR: ON
4	EnergySaver: 2:00
5	Front Panel: BRIGHT
6	Tape Speed: SLP
7	Set Auto Repeat
0	Exit

The PREFERENCES menu allows changes to be made to a variety of different VCR features.

EnergySaver

By default, the VCR automatically turns off after two hours of inactivity. This can be changed in the *PREFERENCES* menu by pressing the 4 button repeatedly to change the time delay or to disable the feature altogether.

- Select *OFF* and the VCR will stay on until you shut it off.
- Select *1:00*, *2:00*, or *3:00* and the VCR will turn off after one, two, or three hours of inactivity.

Thirty seconds before automatically shutting off, the VCR displays an on-screen message reading, *The VCR will turn off in 30 seconds. Press any key to cancel.* Pressing any remote control or VCR front panel button will halt the countdown.

If you use the VCR's tuner instead of your TV to view channels, you may want to turn off this feature.

Front Panel Brightness (VCR Display)

You can change the brightness level of the VCR's front panel display. In the *PREFERENCES* menu, press the 5 button repeatedly to toggle between options:

- *AUTO* means the display brightens when the VCR is on and dims when the VCR is off.
- *BRIGHT* keeps the display bright whether the VCR is on or off.
- *DIM* keeps the display at a low brightness level whether the VCR is on or off.

Recording Speeds

SP (Standard Play)
Gives the best quality recording, but fewer programs can be recorded on the tape.

SLP (Super Long Play)
Gives three times the recording time of tapes recorded in *SP* mode.

Recording Times

Cassette	SP	SLP
T-120	2 Hr	6 Hr
T-160	2 Hr/40 Min	8 Hr

Tape Speed

You can choose a preferred tape speed for recording; either Standard Play (SP) or Super Long Play (SLP). The speed selected appears in the VCR's display panel and in timer recording menus.

To Select a Preferred Tape Speed:

- In the *PREFERENCES* menu, press the 6 button repeatedly to switch between *SP* and *SLP* settings.

Note: For an explanation of recording speeds, see the note to the left.

To Override the Preferred Tape Speed:

- Press the *SPEED* button on the remote control.
- Set the tape speed in the timer recording menu.

When you turn off the VCR, the tape speed reverts to the one you have selected as the default.

```
AUTO REPEAT

Set the length of time
you want the tape to
play in a repeating loop

Loop from 0:00 to -:--
                        (h:mm)
Press CLEAR to turn off
Press MENU to exit
```

Set Auto Repeat

A tape can be set to play the same segment over and over in a repeating loop with the Set Auto Repeat feature. Set Auto Repeat uses the VCR's memory counter to determine the duration of the loop.

In the *PREFERENCES* menu, press the 7 button to choose *Set Auto Repeat*. The *Set Auto Repeat* menu will ask for a loop end time to be specified:

- The CLEAR button will erase all three numbers entered and move the cursor back to the first position (hours).
- The *Press CLEAR to turn off* message will appear only after the first number has been entered into the end time.
- Auto Repeat is set back to --:-- by resetting the dialog box, ejecting a tape, powering off the VCR, power interruption, or by recording start.

When a duration time has been set:

- The VCR will automatically switch to rewind if the counter meets or goes past the set Auto Repeat duration.
- The VCR will automatically switch to playback during rewind if the counter equals or is less than 0:00.
- The Auto Repeat may be adjusted by setting the counter to 00:00. This can be done by pressing the CLEAR button while the tape counter is on screen or on the front panel display.
- The counter will not reset while rewinding in an Auto Repeat loop.

This Page Left Blank Intentionally

Using the Remote Control

Chapter Overview:

- Buttons on the Remote Control
- Programming the Remote to Operate Other Components
- How To Use the Remote After You've Programmed It

Changing Entertainment. Again.



Using the Remote Control

Your VCR's remote control is capable of controlling more than just your VCR. If you have compatible RCA, GE, or Proscan TV, you may be able to control it without any additional steps.

In order for the VCR's remote control to operate a compatible RCA, GE, or Proscan TV, you must first press the TV button on the remote control. For example, if you wanted to change the TV's channel, you would need to hit the TV button first to put the remote control in TV-controlling mode, and then press the CHAN up or down button. To rewind a tape in the VCR, you would first press the VCR button on the remote control to put it into VCR-controlling mode, and then press the REVERSE button.

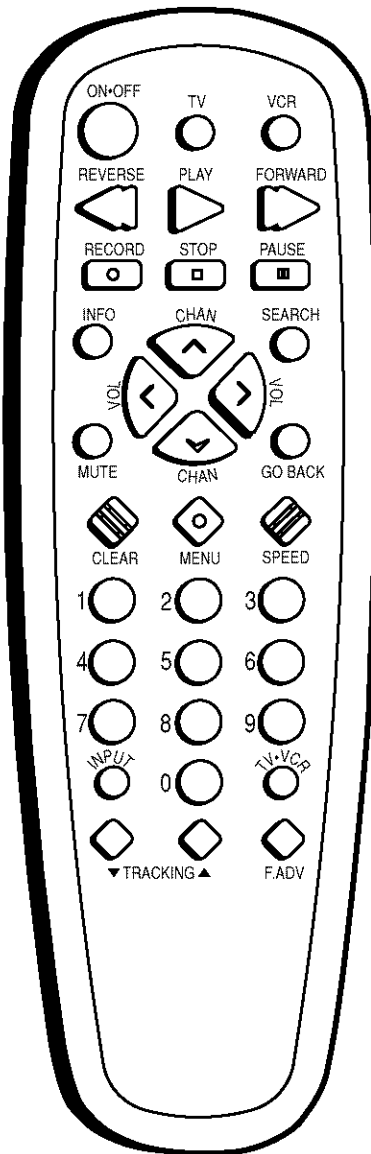

Buttons of the Remote Control

0-9 (Number buttons) Enter channel numbers and time settings directly through the remote control.

To enter a two-digit channel, press the two digits. To enter a three-digit channel, press and hold the first digit for two seconds until two dashes appear to the right of the number, then add the second two. Example: to tune to channel 123, press and hold 1 for two seconds, then, when the dashes appear (--) press 2, then press 3.

CHAN (up and down) buttons Scan up or down through the VCR's stored channels. Press once to change the channel up or down; press and hold to continue changing channels.

CLEAR Removes any menu or display from the screen and returns the display to the normal signal.

FORWARD Advances the tape in the VCR forward. If in PLAY mode, the FORWARD button starts fast-motion scan. If the tape in STOP mode, the FORWARD button starts fast forwarding.

F. ADV (Frame Advance) Advances the tape one frame at a time during play-pause mode.

GO BACK Depending on which component the remote control is set to operate, this button returns the TV or VCR to the previously viewed channel.

INFO Shows the VCR's status displays on the TV screen. Press the INFO button once to display the day, date, time, and tape counter. Press the INFO button a second time to display just the tape counter. Press the INFO button a third time to clear the displays.

INPUT Selects between the video line inputs and the VCR's tuner. Video line input refers to the signal coming from another component connected to the A/V input jacks on the back or front of the VCR.

Using the Remote Control

MENU Displays the VCR's Main Menu. This is the first step when accessing any on-screen menu such as Language, Preferences, Timer Recordings, etc.

MUTE Lowers the TV volume to its minimum level. Press the MUTE button again to restore the TV's volume to its previous level.

ON•OFF Turns the power of the active device (either the TV or VCR) on or off.

PAUSE Pauses playback and recording operations in VCR mode.

PLAY Starts playback when in VCR mode. Pressing PLAY while in Pause mode will also start playback too.

RECORD Starts recording when in VCR mode.

REVERSE If you're operating a VCR with the remote control, press REVERSE to go backwards on a videotape. While in playback mode, pressing and holding REVERSE starts reverse playback.

SEARCH Displays Index and Zero Search menus on-screen. Press this button once to display the Index Search screen and a second time to display the Zero Search screen.

SPEED Overrides the set recording speed (either SP or SLP).

STOP If you're operating a VCR, this button stops playback and recording operations.

TRACKING up and down Allows the manual reduction of streaks which may appear on the picture during regular or slow-motion playback. Reduces picture "jitter" during stop-action (paused) playback.

TV Puts the remote control in TV mode. This button will automatically turn on most RCA, GE, and Proscan TVs.

TV/VCR Toggles the VCR between TV and VCR viewing modes.

VCR Puts the remote control in VCR mode.

VOL (up and down) buttons Decrease or increase the TV volume.

Using the INPUT Button

Use the INPUT button to toggle through the available video line input sources (toggles between video line input(s) and regular broadcasting) and to view the connected component's image (like a camcorder's playback picture) through the VCR.

1. Press the remote control's VCR button to place the remote control in VCR mode. Make sure that the VCR is turned ON.
2. Press the remote control's INPUT button to tune to the video line input source which allows you to see the component's image.
3. Press the INPUT button again to tune back to the broadcast image you were previously watching through the VCR.

Using the Remote Control

Operating a Television with the VCR's Remote Control

The unified remote control that came with your VCR can operate most RCA, GE, and Proscan TVs without any additional steps. To see if the VCR's remote control can operate your RCA, GE, or Proscan TV, point it at the unit and press the TV button to put the remote control into TV-operating mode. Then, press the ON•OFF button. If the TV responds to the command, it can be operated using the VCR's remote control.

Using the VCR's Features

Chapter Overview:

- Recording
- Express Recording (XPR)
- Timer Recordings
- Copying and Editing Tapes

Changing Entertainment. Again.



Recording Features

Your VCR provides many ways to capture programming:

1. **Recording** lets you press one button to record a program.
2. **Express Recording (XPR)** allows recording to start while a program is being watched. This feature automatically stops recording after a designated period of time.
3. **Timer Recording** program the VCR for a daily, weekly, or one-time recording which will automatically start and stop at the times you set.

Express Recording (XPR)

Use XPR to quickly record the remaining portion of a program being watched. XPR is a great way to capture the end of a sporting event that has run into overtime or a live broadcast that runs long.

XPR works in 30-minute increments. You can capture the last 30, 60, 90, etc. minutes of programming (providing on tape length), up to four hours total.

To Activate XPR:

1. If necessary, turn on the VCR and tune it to the channel with the desired programming.
2. If necessary, insert a tape with its safety tab in place into the VCR. Make sure it is cued to record at the proper starting point.
Note: To override the preferred tape speed setting, press the **SPEED** button on the remote control repeatedly to toggle between **SP** and **SLP** choices.
3. Press the **RECORD** button on the remote control or VCR front panel to start recording.
4. Repeatedly press the **RECORD** button to set up the recording duration.
 - Each press of the **RECORD** button adds 30 minutes of recording time.
 - The VCR automatically turns off after recording for the set time.
 - To stop an XPR recording, press and hold the **STOP** button on the remote control or VCR front panel for several seconds until **STOP** appears on the VCR on-screen display.

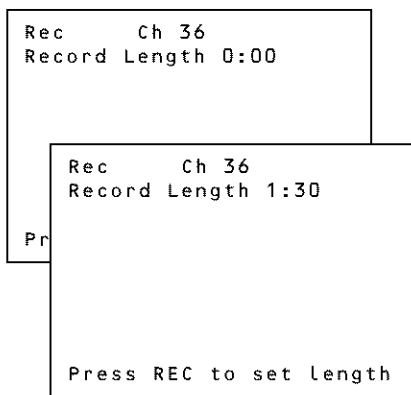

Timer Recording

You can program up to eight different broadcasts to be recorded.

Notes– In order for a timer recording to work:

- The VCR's clock must be set correctly.
- Insert a tape with its safety tab in place and enough tape to record the program.
- If you've set up the VCR for a cable box for all channels, the output of your cable box appears in the channel item of the *Timer Recording* menu.
- *PROGRAMS OVERLAP* appears if two programs whose times overlap are entered.
- *TIMER* appears in the display when you turn off the VCR and a timer recording has been set. *TIMER* flashes if there is no tape in the VCR when a timer recording has been set and the unit is turned off.
- For a cable box or satellite receiver, turn it on and tune it to the channel you want to record before the recording is to begin.

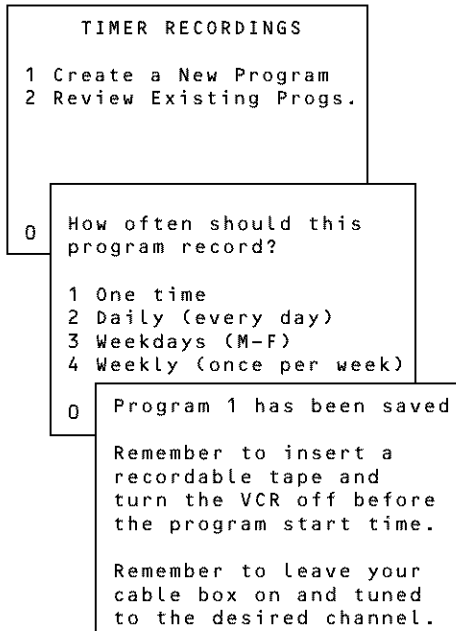

To Set Up to as Many as Eight Timer Recording Programs:

1. Press the MENU button to display the *VCR MAIN MENU*.
2. Press the 2 button to choose *TIMER RECORDINGS*.
3. Press the 1 button to choose *Create a New Program*.
4. Select how often you want the program to record.
5. Enter the data for the program with the number buttons.

The data includes the channel number (press INPUT to select the Video Line Input if using A/V jacks to connect the VCR to the TV), and start and end times (including AM or PM). The start date is automatically entered based on the VCR clock. Both the recording date and speed can be changed.

6. Review the information to make sure it is correct.
7. Press the MENU button to save.

Stopping a Timer Recording

To stop or cancel a timer recording in progress (even an Express Recording):

Press and hold the STOP button for several seconds until *STOP* appears in the on-screen display.

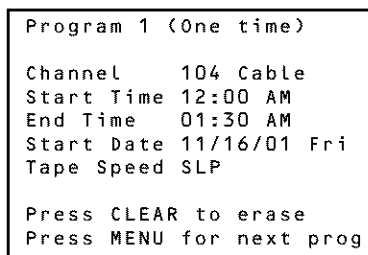

Reviewing and Clearing Programs

To review programs that you have already set up:

1. Press the MENU button to display the *VCR Main Menu*.
2. Press the 2 button to choose *TIMER RECORDINGS*.
3. Press the 2 button to choose *Review Existing Progs.*
4. Press CLEAR to erase or MENU to see the next saved timer recording program.

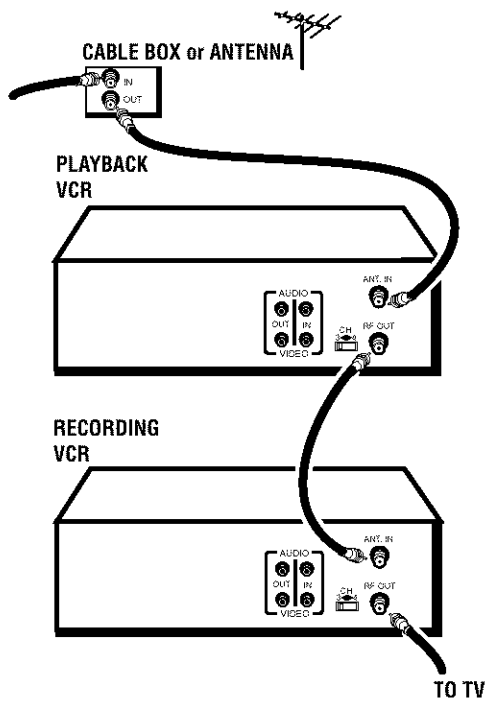

Caution:

The unauthorized recording of satellite broadcasts, television programs, or other copyrighted materials may infringe the rights of others.

Insert Tape:

Don't forget to insert a recorded tape when using the search features.

Copying and Editing Tapes Using Two VCRs

Use one VCR as the *playback* VCR and the other as the *recording* VCR.

1. Turn on the TV and VCRs.
2. Tune the TV to the VCR viewing channel (either 03, 04, or the TV's Video Line Input).
3. If you connected your VCR using the ANT. IN and RF OUT jacks, tune the *recording* VCR to channel 3 or 4—whichever is selected on the back of the *playback* VCR.

If you have connected your VCR using the A/V jacks, press INPUT on the *recording* VCR's remote control to select the Video Line Input.

4. Insert the tape you want to copy into the *playback* VCR. Insert a tape with its safety tab in place into the *recording* VCR.
5. Press PLAY on the *playback* VCR to begin playback. When you reach the point on the tape or program where you want to begin copying, press the PAUSE button. You may need to adjust the tracking.
6. Press the RECORD button, then press PAUSE on the *recording* VCR.
7. Press the PAUSE buttons on *both* VCRs at the same time to begin copying the tape.
8. To edit segments that you do not want to copy:
 - Press PAUSE on *recording* VCR to pause copying.
 - Locate the next segment you want to copy on the *playback* VCR by using FWD, REV, and PLAY, and then press PAUSE.
 - Press PAUSE on *both* VCRs at the same time to resume copying.
9. Press STOP on *both* VCRs when finished.

Picture Search Options

The basic way to search during playback is using the remote control's FORWARD or REVERSE buttons (FWD and REV on the VCR). This section contains several other options available for searching a tape.

Forward and Reverse Search

You can search a tape during playback either forward or reverse in direction.

Note: Sound is turned off during picture search.

1. Press the FORWARD button to search forward or the REVERSE button to search backwards.
2. Press the FORWARD, REVERSE, or PLAY button to return to normal playback.

Slow Motion

You can view a tape during play or play-pause mode using Slow Motion search.

1. In pause mode, press the FORWARD (FWD) or REVERSE (REV) button to start slow-motion playback.
2. Press the FORWARD button to increase or the REVERSE button to decrease the search speed.
3. Use the TRACKING + or – buttons to remove any streaks from the picture.

Note: Some lines cannot be avoided with the VR355 model VCR due to the fact it is a 2-head VCR.

4. Press the PLAY button to return to normal playback.

The VCR switches automatically from slow-motion playback to stop after a few uninterrupted minutes.

Frame Advance

Frame Advance lets you view single-frame action during playback.

1. While playback is in progress, press the remote control's PAUSE button (PLAY/PAUSE on the VCR) to freeze the action.
2. Press the F. ADV button on the remote control each time you want to view the next frame of the recording.
3. Press the PAUSE or PLAY button on the remote control (PLAY/PAUSE on the VCR) to return to normal playback.

Index Search

The VCR has a "VHS Index Search System" that automatically records index marks on the tape every time you start a recording. During playback you can locate the program you want to play by the number of index marks or by scanning. The VCR will search forward or reverse from the location you are at on the tape.

To Activate Index Search:

1. While playing back, press the STOP button to freeze the action.
2. Press the SEARCH button on the remote control to display the *INDEX SEARCH* screen on the TV screen.

```
INDEX SEARCH

Press REV or FWD
to begin scanning
OR
enter a specific
index number
--
Press SEARCH to exit
```

3. If you want to search through a certain number of index marks, press two number buttons to enter the number of marks you want to search. Press the CLEAR button on the remote control to correct an entry.

Continues on next page

VCR Features

4. Press the FORWARD button to search forward or the REVERSE button to search in reverse. The VCR will locate your index mark and begin playback. If you did not enter a specific index number, the VCR will locate the next index mark and begin playback.
5. Press STOP to stop Index Search.

Notes— Certain index marks may be missed by the VCR including:

- Marks too close to the current location of the tape.
- Those at the beginning of a recording lasting five minutes or less.
- Index marks that start at the beginning of the tape.

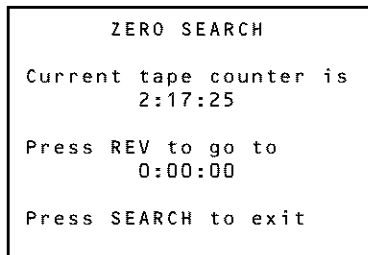

Zero Search

The Zero Search feature enables the VCR to quickly return to the 0:00:00 counter reading from anywhere on the tape. This is a convenient way to play a segment of the tape several times.

1. Cue a tape to the spot you wish to return to.
2. Press the CLEAR button twice to reset the counter to 0:00:00.
3. Continue playing the tape.
4. Press the STOP button.
5. Press the SEARCH button repeatedly until the *ZERO SEARCH* menu appears on screen.
6. Press the REVERSE button (REV on the VCR) to return to 0:00:00 on the tape.
7. Repeat as necessary.



Pro-Tect Plus™ Locking Feature

To disable VCR usage or to protect set timer recordings, the unit can be locked so that the buttons on the VCR or remote control don't work.

- **To Lock:** Press and hold either the remote control's ON•OFF or VCR button until *SAFE* appears in the display to indicate Pro-Tect Plus is active. *SAFE* also appears if the VCR is turned on while the feature is activated.
- **To Unlock:** Press and hold either the remote control's ON•OFF or VCR button until *SAFE* disappears from the front panel display. Unlocking is the only way to use the VCR.

Tracking

Your VCR has automatic tracking which removes streaks and noise from the picture. Automatic tracking is activated when you insert a tape or turn on the VCR. Occasionally you may need to manually adjust tracking, especially if the tape was recorded on a different VCR. Use the TRACKING -/+ buttons on the VCR front panel or remote control to remove streaks and noise. You can also use tracking when pausing a tape to reduce the noise of the stilled picture.

When manually adjusting the picture, automatic tracking is turned off. To turn automatic tracking back on, eject the tape and reinsert it.

Note: Tracking has no effect when recording—only during playback.

Some lines cannot be avoided with the VR355 model VCR due to the fact it is a 2-head VCR.

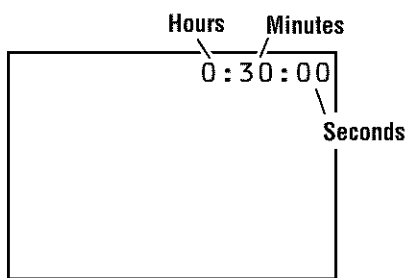

Time Counter

The time counter shows the actual time used when recording or playing back a tape. The time counter helps locate the beginning or end of recorded events. It resets to 0:00:00 whenever a tape is ejected from the VCR.

For example, if you record a 30-minute program at the beginning of a tape, rewind it, and then want to go to the end of the first program to start another recording:

1. Press the INFO button **twice** to display only the time counter.
2. Press the CLEAR button to reset the time counter to 0:00:00.
3. Press the remote control's FORWARD button (FWD on the VCR) to advance a tape until the time counter reads 0:30:00.
4. Press the STOP button. This is the approximate end of a 30-minute program (you may want to press the PLAY button to verify). When the tape is cued correctly, you can begin recording.
5. Press the INFO button to remove the time counter from the screen and return to the normal display mode.

On-Screen Displays

Pressing the INFO button displays the status of the VCR (Stop, Play Record, etc.) as well as the channel number, time counter position, date, time, and tape speed on the TV screen.

Note: The date and time must be set before they can be displayed.

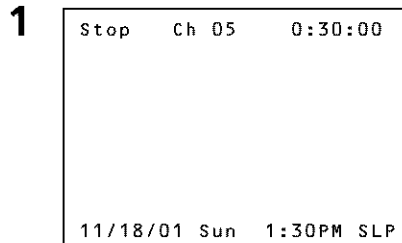

On-screen display (times out)

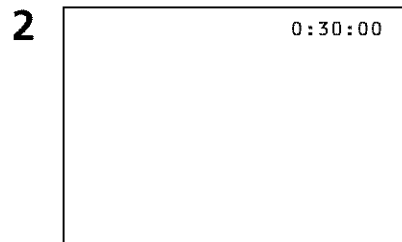

Time counter only (does not time out)



No displays will appear (useful for dubbing)

1. Press the INFO button to show the on-screen displays. The current time is displayed in the VCR's front panel.

2. Press INFO again to have only the time counter remain on the screen. The time counter is also displayed in the VCR's front panel.

3. Press INFO again to have no displays appear on the TV screen. The time counter remains in the VCR's display panel. This is useful for dubbing tapes.

4. Press the INFO button again to return to the normal display. The current time is displayed in the VCR's display panel.

Note: Turning off the VCR also resets the displays.

Other Information

Chapter Overview:

- Troubleshooting
- Front, Rear, and Display Panel Diagram
- Specifications
- Care and Cleaning
- Warranty Information
- Finding the TV's Video Line Input
- Glossary
- Index

Changing Entertainment. Again.



Troubleshooting

Most problems with your VCR are addressed in this Troubleshooting section. If you ever have any problems with the VCR's general, playback, or recording abilities, refer to this section first.

General Problems

No power

- Check to make sure the VCR is plugged into a working outlet.
- Check to make sure connections between devices are correct and snug.

The VCR does not respond to the remote control

- To put the remote control in VCR-operating mode, press the VCR button first. The remote control should then operate the VCR.
- Make sure there are no objects between the VCR and the remote control.
- The remote control's batteries may need changing.
- Remove the remote control's batteries for at least one minute, then replace. This resets the factory default settings, which may require reprogramming to operate other components.

The remote control no longer operates an RCA, GE, or Proscan TV

- Press the TV button to put remote control in TV-controlling mode. The remote control should then operate the TV.

There's poor quality or no picture for normal TV viewing

- If using RF coaxial cables to connect the VCR to the TV, make sure the VCR indicator is not displayed on the VCR's front panel (press the remote control's TV•VCR button to toggle between VCR and TV-viewing modes).

If using A/V jacks and cables to connect the VCR to the TV, press the remote control's INPUT button when in TV-controlling mode to access the TV's Video Line Input).

- Tune the TV to an active channel.
- All cables should be securely inserted and connected to the proper jacks.

Cannot select channels over 69

- Cable channels over 69 can only be selected if Signal Type: CABLE/ANTENNA feature is set to CABLE in the *CHANNELS* menu.

TIMER flashes on the VCR front panel

- The clock is not set.
- Check to make sure there is a tape in the VCR when a timer recording is set.

Rewind does not operate

- Check the tape to insure it is not already rewound.
- Check the tape to insure it is not damaged or broken.

The incorrect time or date is shown

- A power interruption may have occurred and Automatic Clock Set was not turned on or did not work properly. Check the time zone and Daylight-Saving settings in the *TIME* menu.
- Make sure the VCR or cable box is tuned to the time data channel (check with your service provider for information about time data).
- Auto Clock Set is not supported in all areas or by digital satellite receivers. Set the time and date manually using the *TIME* menu.

The time did not adjust for Daylight-Saving Time

- Make sure the Daylight-Saving Time feature is set correctly in the *TIME* menu.

The VCR makes noise when it is stopped

- This is normal. The VCR removes the tape from the playheads when stopping. The cylinders inside the VCR will continue to rotate for a few minutes after stopping.

The VCR will not find active channels correctly using the Auto Channel Search feature

- Make sure all cable connections are secure and correct.
- Make sure that Signal Type: CABLE/ANTENNA, is set correctly in the *CHANNELS* menu.
- If *Detect Automatically* was selected for the Signal Type in the *AUTO CHANNEL SEARCH* menu, try using either CABLE TV or ANTENNA instead.
- Auto Channel Search may not be necessary if using a cable box to view all channels. Contact your local cable company for more information.

On-screen menus appear in a foreign language

- Check the *LANGUAGE* menu to choose a preferred on-screen language.

Playback Problems

Snowy or no picture during playback

- Press the TV•VCR button on the remote control or VCR front panel to go into VCR-viewing mode (*VCR* appears on the VCR's display panel LCD when in VCR-viewing mode).
- Check that the TV channel selected (either 03 or 04) matches the channel set with CH. 3/4 switch on the VCR's back panel.
- Make sure the TV's fine tuning is correct for the channel selected.
- All cables should be securely connected to the proper jacks.
- If using A/V jacks and cables to connect components, make sure the TV is tuned to its Video Line Input to see the VCR's signal.
- Try another tape.
- Picture *noise* is normal during search, stop action, frame advance, and slow-motion playback.

Other Information

Streaks appear in the picture during normal playback

- Press one of the remote control's TRACKING buttons to adjust for the best picture.
- Make sure the tape used is in good condition and not worn out.

Tapes play back in slow motion

- Press the PLAY button to return to normal playback mode.

A tape with its safety tab removed doesn't start to play automatically

- Make sure the Auto Play feature is set to *ON* in the *PREFERENCES* menu.

The time counter is not working or it is not working in search modes

- The time counter does not advance during unrecorded portions of tape. When an unrecorded segment of tape is encountered, the time counter will hold its count until recorded material is detected again.
- A minus sign (–) appears in front of the displayed time if you rewind a tape back further than a counter reading of 0:00:00.

The VCR will not play

- Make sure there is a tape in the VCR.
- Try ejecting, then reinserting the tape.
- Check to make sure the tape is not damaged or broken.
- Make sure the VCR is not in Pause mode. Press the remote control's PAUSE or PLAY button to return to normal playback.
- Make sure the Pro-Tect Plus feature is not activated (press and hold the STOP button on the remote control or VCR front panel for several seconds until *SAFE* disappears from the front panel display to deactivate this feature).
- If unable to record, make sure the safety tab on the tape is in place.

The time counter disappears during picture search

- This is normal.

Recording Problems

The VCR will not record

- Make sure there is a tape in the VCR.
- Try ejecting, then reinserting the tape.
- Check to make sure the tape is not damaged or broken.
- Make sure the VCR is not in Pause mode. Press the remote control's PAUSE or PLAY button to return to normal playback.
- Make sure the Pro-Tect Plus feature is not activated (press and hold the STOP button on the remote control or VCR front panel for several seconds until SAFE disappears from the front panel).
- If unable to record, make sure the safety tab on the tape is in place.

A timer recording didn't record or the wrong program recorded

- Make sure any connected cable box or satellite receiver was turned on when the recording time began.
- Make sure the program information was entered correctly (i.e. channel number and start/stop times).
- A power interruption may have occurred. Reset the time and date and try again.
- Time (including AM or PM) and date information may be incorrect.
- Make sure the timer program did not exceed the tape's length and that the tape was cued correctly.
- Make sure the VCR was turned off when recording started.
- Make sure there was a tape in the VCR and that its safety tab was in place.
- The VCR ejects a tape when its end is reached during a timer recording.

Other Information

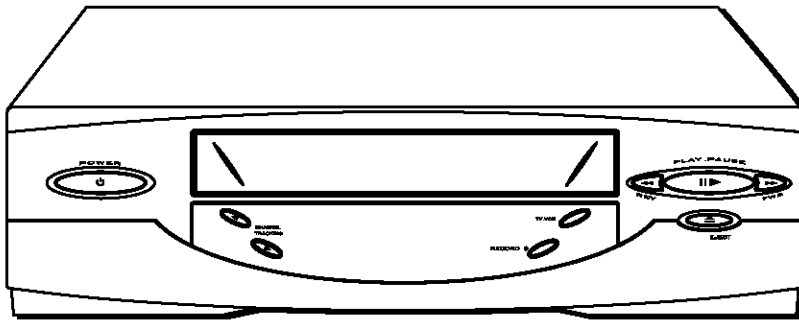

Front Panel

CHANNEL • TRACKING and Up ▲ and Down ▼ Selects next higher or lower channel in the VCR's channel memory. Adjusts tracking when a tape is playing.

FWD Forwards the tape when the VCR is stopped. Searches the picture forward during playback. Starts slow motion during play-pause and increases slow-motion speed.

PLAY • PAUSE Plays a tape. Pauses action for viewing during playback. Pauses recording to prevent recording of unwanted scenes.

POWER Turns the VCR on or off.

RECORD Starts VCR recording. Used for express recording.

REV Rewinds the tape when the VCR is stopped. Searches the picture in reverse during playback. Starts slow motion during play-pause and decreases slow-motion speed.

STOP • EJECT A single press of this button stops normal VCR functions such as record, playback, rewind, fast-forward, or pause. If pressed a second time, this button ejects an inserted tape.

TV • VCR Switches the picture signal so that it either comes from the VCR or the TV cable/antenna signal.



Display Panel

Clock/Counter Displays current time, time counter, tape speed, or channel numbers when switching channels.

FUNCTION DISPLAYS:

- BYE** The VCR is turned off.
- EJEC** A tape is being ejected.
- FF** A tape is fast-forwarding.
- HI** The VCR is turned on.
- PLAY** A tape is in playback mode.
- PLAY (Flashing)** Playback is paused; a still-frame image is displayed.
- REC** The VCR is recording. Also denotes a timer recording in progress.
- REC (Flashing)** A recording is paused.
- REW** A tape is rewinding.
- SAFE** The Pro-Tect Plus™ locking feature is active.
- SRCH** The VCR is searching forward.
- SRCH** The VCR is searching in reverse.
- SLOW** A tape is playing back in slow motion.
- STOP** A tape is in stop mode.
- 0:00, 0:30, 1:00, etc.** An Express Recording is in progress.

Tape In indicator (⏏) Displays when the VCR has a tape inserted.

TIMER Displayed when an Express Recording (XPR) or timer recording is under way or when the VCR is set for a timer recording and the power is turned OFF. *TIMER* flashes on the VCR front panel when a timer recording is set and no tape is inserted in the VCR.

VCR indicator Indicates that the VCR is in VCR-display mode. Press the TV•VCR button to toggle between VCR and TV viewing modes.

- VCR indicator is ON when the picture displayed is from the VCR's tuner.
- VCR indicator is OFF when the picture displayed is from the TV's tuner.

Other Information

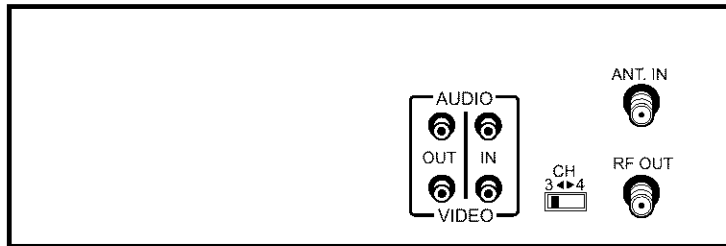

Back Panel

ANT. IN jack Receives an antenna or cable system signal when the VCR is attached using RF coaxial cables.

AUDIO and VIDEO IN jacks Receives signals from another component (such as a VCR or camcorder) when connected to these jacks. Use the INPUT button on the remote control to select the Video Line Input when recording from these jacks.

AUDIO and VIDEO OUT jacks Sends signals from the VCR to another component (like a TV or VCR), when connected to these jacks.

CH. 3/4 switch Determines the channel which the TV must be tuned to in order to see the VCR's picture. Not used when connecting the VCR to the TV using Audio/Video cables.

RF OUT jack Passes the VCR's signal to the TV using the supplied RF coaxial cable.

<h2>Specifications (VR355)</h2>	<h2>Specifications (VR545)</h2>
Format: VHS	Format: VHS
Record/Playback System: Video: 2-head Audio: VHS Mono record playback system	Record/Playback System: Video: 4-head Audio: VHS Mono record playback system
Video Signal System: EIA standard: NTSC color	Video Signal System: EIA standard: NTSC color
Antenna: 75-ohm external VHF/UHF combined antenna terminal	Antenna: 75-ohm external VHF/UHF combined antenna terminal
Tuner: USA: 181 channels capability* (125 cable channels) Canada: 178 channels capability* (122 cable channels)	Tuner: USA: 181 channels capability* (125 cable channels) Canada: 178 channels capability* (122 cable channels)
Type: AutoProgramming frequency synthesis	Type: AutoProgramming frequency synthesis
Power Requirement: 120V AC, 60 Hz	Power Requirement: 120V AC, 60 Hz
Power Consumption: 16 watts (standby < 3.3 watts)	Power Consumption: 23 watts (standby < 3.3 watts)
Dimensions: 3.7 inches high (94 mm) 14.2 inches wide (360 mm) 9.4 inches deep (240 mm)	Dimensions: 3.7 inches high (94 mm) 14.2 inches wide (360 mm) 9.4 inches deep (240 mm)
Weight: 5.72 pounds (2.7 kg)	Weight: 5.72 pounds (2.7 kg)
Storage Temperature Range: -22°F to +149°F (-30°C to +65°C)	Storage Temperature Range: -22°F to +149°F (-30°C to +65°C)
Operating Temperature Range: +41°F to +104°F (+5°C to +40°C)	Operating Temperature Range: +41°F to +104°F (+5°C to +40°C)
*Check your cable company's compatibility requirements.	*Check your cable company's compatibility requirements.

Cleaning the VCR

Use a soft cloth or dusting attachment of your vacuum cleaner to dust your VCR. Remove dust from the ventilation holes on the top, back, sides, and bottom of the VCR and all connected components.

Plastic surfaces are easily scratched and can be marred by alcohol and various solvents. Avoid excessive use of oil-based furniture polishes since the materials used in the cabinet will accumulate more dust. We recommend using a nonabrasive, antistatic cleaner and polisher.

Other Information

How to Find Your TV's Video Input Channel

You need to tune your TV to the video line input if you are using the VCR's Audio/Video (A/V) OUT jacks to connect to the TV's A/V input jacks. You must select the video line input before you can see the VCR's menus, the cable/antenna reception, and the content that's on a tape.

The video line input for TVs varies by brand and model. Below are some steps to try to find your TV's video line input:

- If your TV brand is RCA, GE, or Proscan, press the TV button on the VCR's remote control, then press the INPUT button.

If those options do not work, try the following ideas. You might access the video line input by:

- Pressing a button on the TV's remote control (see table below).
- Selecting a specific channel from the TV's on-screen menu system (see table below).
- Tuning directly to the video line input by selecting a specific channel number (see table below)
- Going through all available channels by pressing the channel up or down buttons on the TV or its remote control.

Common Video Line Input scenarios:

Video Input Channel Variations		
Button/Switch on the TV	Button on the TV Remote	Channel Number
VIDEO	VID 1	00
SIGNAL	LINE	90
VID 1	VID	91
VID 2	VIDEO	92
S-VID	S-VID	93
S-VIDEO	INPUT	VID 1
	S-VIDEO	VID 2
	SOURCE	
	AUX	

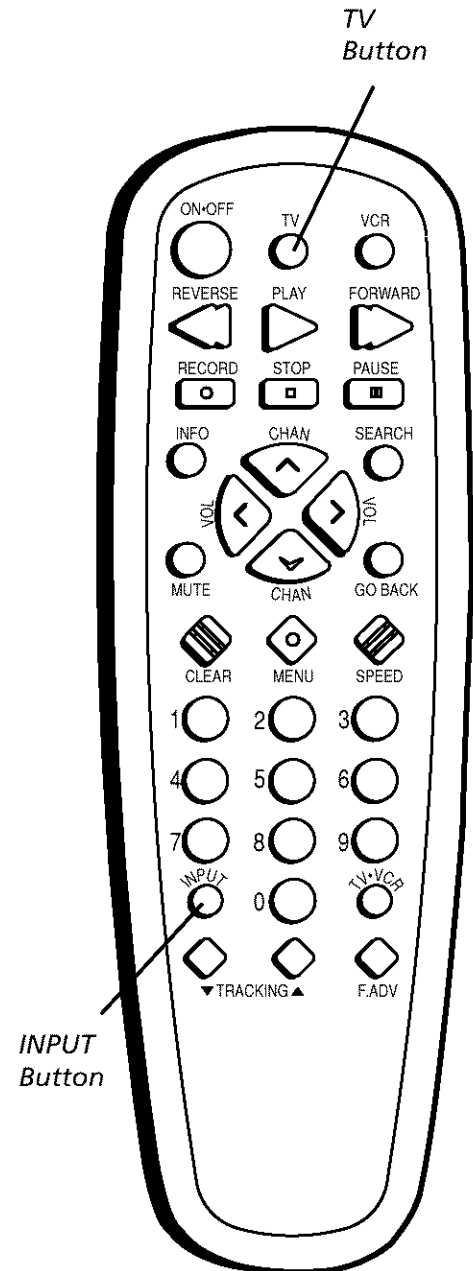

Advanced Connection

TV + VCR + Satellite Receiver

- **Cables: A/V and RF Coaxial**

Note: Your satellite receiver and television back panels may not look exactly like the models shown here. This connection can also be used for a cable box.

1. Connect the VCR to the TV

- Connect one end of the supplied RF coaxial cable to the RF OUT jack on the back of the VCR and the other end to the TV's antenna input jack.
- Connect the A/V cables. Connect an audio cable to the VCR's Audio OUT jack and the other end to the TV's corresponding audio input jack (if your TV has more than one audio input jack, use the L channel jack to make the connection). Connect one end of the video cable to the VCR's VIDEO OUT jack, and the other end to the TV's video input jack.



2. Connect the satellite receiver to the VCR

- Connect one end of a second RF coaxial cable (not included) to the VCR's ANT. IN jack. Connect the other end to the satellite receiver's antenna output jack.
- Connect the A/V cables. Connect an audio cable to the VCR's Audio IN jack and the other end to the satellite receiver's audio output jack (if your satellite receiver has more than one audio out jack, use the L channel jack to make the connection). Connect one end of the video cable to the VCR's VIDEO IN jack, and the other end to the receiver's video output jack.

3. Connect a TV antenna or cable feed to the satellite receiver

If you have cable or a standard TV antenna, connect its RF coaxial cable (not included) to the antenna input jack on the satellite receiver.

4. Connect the satellite antenna's cable to the satellite receiver

Connect the satellite antenna's RF coaxial cable feed (not included) to the receiver's satellite input jack.

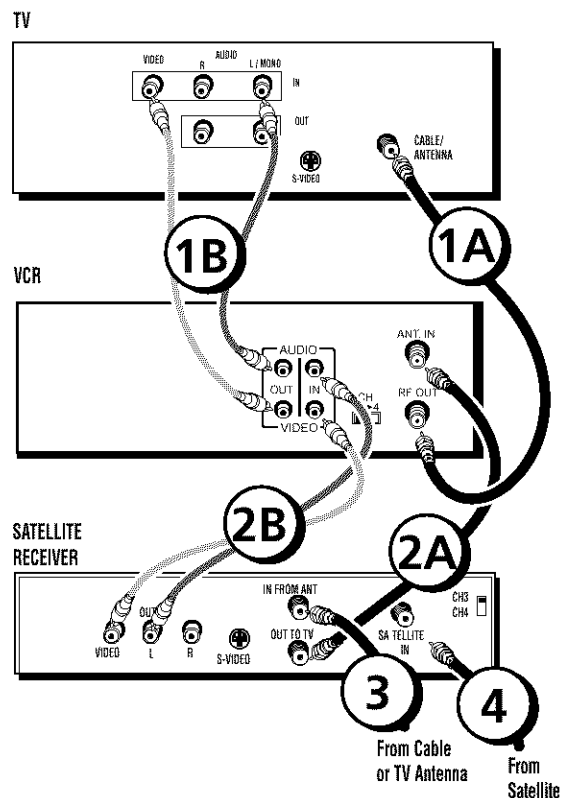

Other Information

RCA VCR Limited Warranty

What your warranty covers:

- Any defect in materials or workmanship.

For how long after your purchase:

- 90 days for labor charges.
- One year for parts.

The warranty period for rental units begins with the first rental or 45 days from date of shipment to the rental firm, whichever comes first.

What we will do:

- Pay any Authorized RCA VCR Service Center the labor charges to repair your VCR.
- Pay any Authorized RCA VCR Service Center for the new or, at our option, refurbished replacement parts required to repair your VCR.

How you get service:

- Take your VCR to any Authorized RCA VCR Service Center. To identify your nearest Authorized RCA VCR Service Center, ask your dealer, look in the Yellow Pages, or call 1-800-336-1900.
- Show the Authorized Service Center Representative your evidence of purchase date or first rental.
- Pick up your VCR when repairs are completed.

What your warranty *does not* cover:

- Customer instruction. (Your Owner's Manual clearly describes how to install, adjust, and operate your VCR. Any additional information should be obtained from your dealer.)
- Installation and related adjustments.
- Signal reception problems not caused by your VCR.
- Damage from misuse or neglect.
- Cleaning of video/audio heads.
- Batteries.
- A VCR that has been modified or incorporated into other products or is used for institutional or other commercial purposes.
- A VCR purchased or serviced outside the U.S.A.
- Acts of nature, such as but not limited to lightning damage.

Product Registration:

- Please complete and mail the Product Registration Card packed with your VCR. It will make it easier to contact you should it ever be necessary. The return of the card is not required for warranty coverage.

How State Law relates to warranty:

- This warranty gives you specific legal rights and you also may have other rights that vary from state to state.

If you purchased your VCR unit outside the United States:

- This warranty does not apply. Contact your dealer for warranty information.

Service calls which do not involve defective materials or workmanship are not covered by this warranty. Costs of such service calls are the sole responsibility of the purchaser.

Glossary

A/V Jacks & Cables Commonly called “RCA-type” cables. Improves picture and sound quality over RF Coaxial cables. A/V cables are required to play sound through a stereo.

EnergySaver Automatically turns the VCR off after a user-defined period of inactivity.

Express Recording (XPR) A method of timer recording which tapes for a set period of time using 30-minute increments.

Pro-Tect Plus™ Allows the VCR to be disabled so that the front panel and remote control buttons don't work. Useful for protecting timer recordings.

QuickSet Guide An first-time use, interactive, menu-based system that walks you through several setup steps in a series of questions. The QuickSet Guide is also available in the VCR's Main Menu.

VCR Channels List The active list of channels available to the VCR using the CHANNEL +/- buttons.

XPR See *Express Recording*.

Index

A

ADD/REMOVE CHANNELS screen 18
Arrow buttons 42
AUDIO IN jacks 47
Audio/Video (A/V) jacks 17, 44
Auto channel search 17
Auto clock feature 19
Auto play feature 13, 21
Auto TV/VCR feature 21
Automatic rewind 13
Automatic tracking 13, 35

B

Back panel jacks 44
Basic recording 13
Batteries (remote control) 11
BYE display 43

C

Cable box setup 16
Cables
 positioning 6
CH + button 26
CH - button 26
CHANNEL buttons 17, 42
Channels, adding/removing 18
CHANNELS menu 16, 18
CLEAR button 26, 33
Clock display 43
Connections 8
Controls
 back panel 44
 front panel 42
Copying tapes 32

D

Date and time setting 19
Design specifications 45
Display panel 43
Displays, on screen 36

E

EJECT button 13
EnergySaver feature 22
Express Recording (XPR) 1, 30

F

F. ADV button 33
FF display 43
FORWARD button 13, 26, 32
Frame advance 33
Front panel controls 42
FWD button 32, 35, 42

G

GO BACK button 26

H

HI display 43

I

Index search 33
Indicators (display panel) 43
INFO button 35
INPUT button 31, 32, 46

L

LANGUAGE menu 16
Locking feature 34

M

MENU button 16, 31
MUTE button 27

N

Number buttons 20, 26

O

ON•OFF button 34
On-screen displays 36
Overheating 6

P

PAUSE button 13, 27, 32
Picture search options 32
PLAY button 13, 27, 32
PLAY display 43
PLAY/PAUSE button 33
POWER button 13
Power surges 6
Pro-Tect Plus 34

Q

QuickSet guide 16

R

REC display 43
RECORD button 13, 30, 42
Recording
 basic 13
 copying /editing tapes 32
 Express (XPR) 1, 30
 speeds 22, 24
 timer 31
Remote, batteries 11
Removing/adding channels 18
REV button 32, 42
REVERSE button 13, 27, 32
Reviewing timer programs 31
REW display 43
Rewind, automatic 13

S

- SAFE display 34
- Safety tab 13, 21
- Search
 - forward 32
 - reverse 32
- SEARCH button 33
- Set up
 - auto play feature 21
 - auto TV/VCR feature 21
 - cable box 16
 - Daylight-saving 20
 - front panel 22
 - language feature 16
 - PREFERENCES menu 20
 - tape speed feature 22
 - time and date 19
 - time zone 19
 - using menu system 16
- Signal type
 - changing 18
 - selecting 18
- SLOW display 43
- Slow motion 33
- Specifications 45
- Speed
 - SLP 22
 - SP 22
- SPEED button 13, 22, 30
- Speeds, recording 22
- SRCH displays 43
- STOP button 13, 27, 30, 34, 42
- STOP display 43

T

- Tab, safety 13
- Tape eject 13
- Tape speeds 22
- Time and date 19
- Time counter 35
- Time counter display 36
- Time display on TV 36

- Timer programs
 - clearing 31
 - reviewing 31
- Timer recording 31
 - stopping 31
- Tracking 35
- TRACKING buttons
 - 13, 27, 33, 35, 42
- Troubleshooting 38
- TV button 27, 46
- TV•VCR button 21
- TV's video input channel 46

V

- VCR
 - connecting 8
- VCR indicator 43
- VCR MAIN MENU 16, 19
- VCR viewing channel 11, 13
- VOL+ button 27
- VOL- button 27

Z

- Zero search 34

This page left blank intentionally

This page left blank intentionally

Please do not send any products to the Indianapolis address listed in this manual or on the carton. This will only add delays in service for your product.

Thomson multimedia Inc.

10330 North Meridian Street
Indianapolis, IN 46290

©2001 Thomson multimedia Inc.
Trademark(s)® Registered
Marca(s) Registrada(s)
Printed in Indonesia
TOCOM 1570808A