

Owner's Manual



Permanently Lubricated Single Stage Horizontal Portable **AIR COMPRESSOR**

Model No.
919.165180

- **Safety Guidelines**
- **Assembly**
- **Operation**
- **Maintenance**
- **Service and Adjustments**
- **Troubleshooting**
- **Repair Parts**
- **Español**

CAUTION: Read the Safety Guidelines
and All Instructions Carefully Before
Operating.

Sears, Roebuck and Co., Hoffman Estates, IL 60170 U.S.A.
Visit our Craftsman website: www.sears.com/craftsman

TABLE OF CONTENTS

WARRANTY2
SPECIFICATION CHART3
SAFETY GUIDELINES3-8
GLOSSARY9
ACCESSORIES9
DUTY CYCLE9
ASSEMBLY10
INSTALLATION11-12
OPERATION13-15
MAINTENANCE16-17
SERVICE AND ADJUSTMENTS18-19
STORAGE20
TROUBLESHOOTING GUIDE21-23
REPAIR PARTS24-27
ESPAÑOL28-49
HOW TO ORDER REPAIR PARTSback cover

WARRANTY

FULL ONE YEAR WARRANTY AIR COMPRESSOR

If this air compressor fails due to a defect in material or workmanship within one year from the date of purchase, RETURN IT TO THE NEAREST SEARS REPAIR CENTER THROUGHOUT THE UNITED STATES AND SEARS WILL REPAIR IT, FREE OF CHARGE. If purchased from Orchard Supply Hardware, return to the nearest Orchard Store and Orchard will repair it, free of charge.

If this air compressor is used for commercial or rental purposes, the warranty will apply for ninety days from the date of purchase.

This warranty gives you specific legal rights and you may have other rights which vary from state to state.

Sears, Roebuck and Co., Dept. 817WA, Hoffman Estates, IL 60179

SPECIFICATION TABLE

Model No.	919-165180
Max. Developed HP	5.5
Bore	2.38"
Stroke	1.35"
Voltage-Single Phase	120
Minimum Branch Circuit Requirement	15 amps
Fuse Type	Time Delay
Air Tank Capacity	25 gallons
Approximate Cut-in Pressure	110
Approximate Cut-out Pressure	135
SCFM @ 40 psig	8.4
SCFM @ 90 psig	6.2

Refer to Glossary for abbreviations.

SAFETY GUIDELINES - DEFINITIONS

This manual contains information that is important for you to know and understand. This information relates to protecting **YOUR SAFETY** and **PREVENTING EQUIPMENT PROBLEMS**. To help you recognize this information, we use the symbols below. Please read the manual and pay attention to these sections.

<p>▲ DANGER Indicates an imminently hazardous situation which, if not avoided, <u>will</u> result in <u>death or serious injury</u>.</p>	<p>▲ CAUTION Indicates a potentially hazardous situation which, if not avoided, <u>may</u> result in <u>minor or moderate injury</u>.</p>
<p>▲ WARNING Indicates a potentially hazardous situation which, if not avoided, <u>could</u> result in <u>death or serious injury</u>.</p>	<p>CAUTION Used without the safety alert symbol indicates a potentially hazardous situation which, if not avoided, may result in <u>property damage</u>.</p>

IMPORTANT SAFETY INSTRUCTIONS

▲ WARNING Some dust created by power sanding, sawing, grinding, drilling, and other construction activities contains chemicals known (to the State of California) to cause cancer, birth defects or other reproductive harm. Some examples of these chemicals are:

- lead from lead-based paints
- crystalline silica from bricks and cement and other masonry products
- arsenic and chromium from chemically-treated lumber

Your risk from these exposures varies, depending on how often you do this type of work. To reduce your exposure to these chemicals: work in a well ventilated area, and work with approved safety equipment, always wear **MSHA/NIOSH** approved, properly fitting face mask or respirator when using such tools.

When using air tools, basic safety precautions should always be followed to reduce the risk of personal injury.

IMPORTANT SAFETY INSTRUCTIONS



SAVE THESE INSTRUCTIONS



IMPROPER OPERATION OR MAINTENANCE OF THIS PRODUCT COULD RESULT IN SERIOUS INJURY AND PROPERTY DAMAGE. READ AND UNDERSTAND ALL WARNINGS AND OPERATING INSTRUCTIONS BEFORE USING THIS EQUIPMENT.

HAZARD

WARNING: RISK OF EXPLOSION OR FIRE



WHAT CAN HAPPEN	HOW TO PREVENT IT
IT IS NORMAL FOR ELECTRICAL CONTACTS WITHIN THE MOTOR AND PRESSURE SWITCH TO SPARK.	ALWAYS OPERATE THE COMPRESSOR IN A WELL VENTILATED AREA FREE OF COMBUSTIBLE MATERIALS, GASOLINE OR SOLVENT VAPORS.
IF ELECTRICAL SPARKS FROM COMPRESSOR COME INTO CONTACT WITH FLAMMABLE VAPORS, THEY MAY IGNITE, CAUSING FIRE OR EXPLOSION.	IF SPRAYING FLAMMABLE MATERIALS, LOCATE COMPRESSOR AT LEAST 20 FEET AWAY FROM SPRAY AREA. AN ADDITIONAL LENGTH OF HOSE MAY BE REQUIRED. STORE FLAMMABLE MATERIALS IN A SECURE LOCATION AWAY FROM COMPRESSOR.
RESTRICTING ANY OF THE COMPRESSOR VENTILATION OPENINGS WILL CAUSE SERIOUS OVERHEATING AND COULD CAUSE FIRE.	NEVER PLACE OBJECTS AGAINST OR ON TOP OF COMPRESSOR. OPERATE COMPRESSOR IN AN OPEN AREA AT LEAST 12 INCHES AWAY FROM ANY WALL OR OBSTRUCTION THAT WOULD RESTRICT THE FLOW OF FRESH AIR TO THE VENTILATION OPENINGS. OPERATE COMPRESSOR IN A CLEAN, DRY, WELL VENTILATED AREA. DO NOT OPERATE UNIT INDOORS OR IN ANY CONFINED AREA.
UNATTENDED OPERATION OF THIS PRODUCT COULD RESULT IN PERSONAL INJURY OR PROPERTY DAMAGE. TO REDUCE THE RISK OF FIRE, DO NOT ALLOW THE COMPRESSOR TO OPERATE UNATTENDED.	ALWAYS REMAIN IN ATTENDANCE WITH THE PRODUCT WHEN IT IS OPERATING. ALWAYS DISCONNECT ELECTRICAL POWER BY MOVING PRESSURE SWITCH LEVER TO THE OFF POSITION AND DRAIN TANK DAILY OR AFTER EACH USE.

HAZARD

WARNING: RISK OF BURSTING



AIR TANK: THE FOLLOWING CONDITIONS COULD LEAD TO A WEAKENING OF THE TANK, AND RESULT IN A VIOLENT TANK EXPLOSION AND COULD CAUSE PROPERTY DAMAGE OR SERIOUS INJURY.

WHAT CAN HAPPEN	HOW TO PREVENT IT
<ol style="list-style-type: none"> 1. FAILURE TO PROPERLY DRAIN CONDENSED WATER FROM THE TANK, CAUSING RUST AND THINNING OF THE STEEL TANK. 2. MODIFICATIONS OR ATTEMPTED REPAIRS TO THE TANK. 3. UNAUTHORIZED MODIFICATIONS TO THE UNLOADER VALVE, SAFETY VALVE, OR ANY OTHER COMPONENTS WHICH CONTROL TANK PRESSURE. 4. EXCESSIVE VIBRATION CAN WEAKEN THE AIR TANK AND CAUSE RUPTURE OR EXPLOSION. 	<p>DRAIN TANK DAILY OR AFTER EACH USE. IF TANK DEVELOPS A LEAK, REPLACE IT IMMEDIATELY WITH A NEW TANK OR REPLACE THE ENTIRE COMPRESSOR.</p> <p>NEVER DRILL INTO, WELD, OR MAKE ANY MODIFICATIONS TO THE TANK OR ITS ATTACHMENTS.</p> <p>THE TANK IS DESIGNED TO WITHSTAND SPECIFIC OPERATING PRESSURES. NEVER MAKE ADJUSTMENTS OR PARTS SUBSTITUTIONS TO ALTER THE FACTORY SET OPERATING PRESSURES.</p>
<p><u>ATTACHMENTS & ACCESSORIES:</u> EXCEEDING THE PRESSURE RATING OF AIR TOOLS, SPRAY GUNS, AIR OPERATED ACCESSORIES, TIRES AND OTHER INFLATABLES CAN CAUSE THEM TO EXPLODE OR FLY APART, AND COULD RESULT IN SERIOUS INJURY.</p>	<p>FOR ESSENTIAL CONTROL OF AIR PRESSURE, YOU MUST INSTALL A PRESSURE REGULATOR AND PRESSURE GAUGE TO THE AIR OUTLET (IF NOT EQUIPPED) OF YOUR COMPRESSOR. FOLLOW THE EQUIPMENT MANUFACTURERS RECOMMENDATION AND NEVER EXCEED THE MAXIMUM ALLOWABLE PRESSURE RATING OF ATTACHMENTS. NEVER USE COMPRESSOR TO INFLATE SMALL LOW-PRESSURE OBJECTS SUCH AS CHILDREN'S TOYS, FOOTBALLS, BASKETBALLS, ETC.</p>

HAZARD

WARNING: RISK FROM FLYING OBJECTS



WHAT CAN HAPPEN	HOW TO PREVENT IT
<p>THE COMPRESSED AIR STREAM CAN CAUSE SOFT TISSUE DAMAGE TO EXPOSED SKIN AND CAN PROPEL DIRT, CHIPS, LOOSE PARTICLES AND SMALL OBJECTS AT HIGH SPEED, RESULTING IN PROPERTY DAMAGE OR PERSONAL INJURY.</p>	<p>ALWAYS WEAR ANSI Z87.1 APPROVED SAFETY GLASSES WITH SIDE SHIELDS WHEN USING THE COMPRESSOR.</p> <p>NEVER POINT ANY NOZZLE OR SPRAYER TOWARD ANY PART OF THE BODY OR AT OTHER PEOPLE OR ANIMALS.</p> <p>ALWAYS TURN THE COMPRESSOR OFF AND BLEED PRESSURE FROM THE AIR HOSE AND TANK BEFORE ATTEMPTING MAINTENANCE, ATTACHING TOOLS OR ACCESSORIES.</p>

HAZARD

WARNING: RISK OF ELECTRICAL SHOCK



WHAT CAN HAPPEN	HOW TO PREVENT IT
YOUR AIR COMPRESSOR IS POWERED BY ELECTRICITY. LIKE ANY OTHER ELECTRICALLY POWERED DEVICE, IF IT IS NOT USED PROPERLY IT MAY CAUSE ELECTRIC SHOCK.	NEVER OPERATE THE COMPRESSOR OUTDOORS WHEN IT IS RAINING OR IN WET CONDITIONS. NEVER OPERATE COMPRESSOR WITH PROTECTIVE COVERS REMOVED OR DAMAGED.
REPAIRS ATTEMPTED BY UNQUALIFIED PERSONNEL CAN RESULT IN SERIOUS INJURY OR DEATH BY ELECTROCUTION.	ANY ELECTRICAL WIRING OR REPAIRS REQUIRED ON THIS PRODUCT SHOULD BE PERFORMED BY AUTHORIZED SERVICE CENTER PERSONNEL IN ACCORDANCE WITH NATIONAL AND LOCAL ELECTRICAL CODES.
ELECTRICAL GROUNDING: FAILURE TO PROVIDE ADEQUATE GROUNDING TO THIS PRODUCT COULD RESULT IN SERIOUS INJURY OR DEATH FROM ELECTROCUTION. SEE GROUNDING INSTRUCTIONS.	MAKE CERTAIN THAT THE ELECTRICAL CIRCUIT TO WHICH THE COMPRESSOR IS CONNECTED PROVIDES PROPER ELECTRICAL GROUNDING, CORRECT VOLTAGE AND ADEQUATE FUSE PROTECTION.

HAZARD

WARNING: RISK TO BREATHING



WHAT CAN HAPPEN	HOW TO PREVENT IT
THE COMPRESSED AIR DIRECTLY FROM YOUR COMPRESSOR IS NOT SAFE FOR BREATHING. THE AIR STREAM MAY CONTAIN CARBON MONOXIDE, TOXIC VAPORS, OR SOLID PARTICLES FROM THE TANK. BREATHING THESE CONTAMINANTS CAN CAUSE SERIOUS INJURY OR DEATH.	AIR OBTAINED DIRECTLY FROM THE COMPRESSOR SHOULD NEVER BE USED TO SUPPLY AIR FOR HUMAN CONSUMPTION. IN ORDER TO USE AIR PRODUCED BY THIS COMPRESSOR FOR BREATHING, SUITABLE FILTERS AND IN-LINE SAFETY EQUIPMENT MUST BE PROPERLY INSTALLED. IN-LINE FILTERS AND SAFETY EQUIPMENT USED IN CONJUNCTION WITH THE COMPRESSOR MUST BE CAPABLE OF TREATING AIR TO ALL APPLICABLE LOCAL AND FEDERAL CODES PRIOR TO HUMAN CONSUMPTION.
SPRAYED MATERIALS SUCH AS PAINT, PAINT SOLVENTS, PAINT REMOVER, INSECTICIDES, WEED KILLERS, MAY CONTAIN HARMFUL VAPORS AND POISONS.	WORK IN AN AREA WITH GOOD CROSS-VENTILATION. READ AND FOLLOW THE SAFETY INSTRUCTIONS PROVIDED ON THE LABEL OR SAFETY DATA SHEETS FOR THE MATERIAL YOU ARE SPRAYING. USE A NIOSH/MSHA APPROVED RESPIRATOR DESIGNED FOR USE WITH YOUR SPECIFIC APPLICATION.

HAZARD

WARNING: RISK OF BURNS



WHAT CAN HAPPEN	HOW TO PREVENT IT
TOUCHING EXPOSED METAL SUCH AS THE COMPRESSOR HEAD OR OUTLET TUBES, CAN RESULT IN SERIOUS BURNS.	NEVER TOUCH ANY EXPOSED METAL PARTS ON COMPRESSOR DURING OR IMMEDIATELY AFTER OPERATION. COMPRESSOR WILL REMAIN HOT FOR SEVERAL MINUTES AFTER OPERATION. DO NOT REACH AROUND PROTECTIVE SHROUDS OR ATTEMPT MAINTENANCE UNTIL UNIT HAS BEEN ALLOWED TO COOL.

HAZARD

WARNING: RISK FROM MOVING PARTS



WHAT CAN HAPPEN	HOW TO PREVENT IT
MOVING PARTS SUCH AS THE PULLEY, FLYWHEEL AND BELT CAN CAUSE SERIOUS INJURY IF THEY COME INTO CONTACT WITH YOU OR YOUR CLOTHING.	NEVER OPERATE THE COMPRESSOR WITH GUARDS OR COVERS WHICH ARE DAMAGED OR REMOVED.
ATTEMPTING TO OPERATE COMPRESSOR WITH DAMAGED OR MISSING PARTS OR ATTEMPTING TO REPAIR COMPRESSOR WITH PROTECTIVE SHROUDS REMOVED CAN EXPOSE YOU TO MOVING PARTS AND CAN RESULT IN SERIOUS INJURY.	ANY REPAIRS REQUIRED ON THIS PRODUCT SHOULD BE PERFORMED BY AUTHORIZED SERVICE CENTER PERSONNEL.

HAZARD

WARNING: RISK OF FALLING



WHAT CAN HAPPEN	HOW TO PREVENT IT
A PORTABLE COMPRESSOR CAN FALL FROM A TABLE, WORKBENCH OR ROOF CAUSING DAMAGE TO THE COMPRESSOR AND COULD RESULT IN SERIOUS INJURY OR DEATH TO THE OPERATOR.	ALWAYS OPERATE COMPRESSOR IN A STABLE SECURE POSITION TO PREVENT ACCIDENTAL MOVEMENT OF THE UNIT. NEVER OPERATE COMPRESSOR ON A ROOF OR OTHER ELEVATED POSITION. USE ADDITIONAL AIR HOSE TO REACH HIGH LOCATIONS.

HAZARD

WARNING: RISK OF PROPERTY DAMAGE WHEN TRANSPORTING COMPRESSOR



(Fire, Inhalation, Damage to Vehicle Surfaces)

WHAT CAN HAPPEN	HOW TO PREVENT IT
OIL CAN LEAK OR SPILL AND COULD RESULT IN FIRE OR BREATHING HAZARD, SERIOUS INJURY OR DEATH CAN RESULT. OIL LEAKS WILL DAMAGE CARPET, PAINT OR OTHER SURFACES IN VEHICLES OR TRAILERS.	ALWAYS PLACE COMPRESSOR ON A PROTECTIVE MAT WHEN TRANSPORTING TO PROTECT AGAINST DAMAGE TO VEHICLE FROM LEAKS. REMOVE COMPRESSOR FROM VEHICLE IMMEDIATELY UPON ARRIVAL AT YOUR DESTINATION.

HAZARD

WARNING: RISK OF UNSAFE OPERATION



WHAT CAN HAPPEN	HOW TO PREVENT IT
UNSAFE OPERATION OF YOUR AIR COMPRESSOR COULD LEAD TO SERIOUS INJURY OR DEATH TO YOU OR OTHERS.	REVIEW AND UNDERSTAND ALL INSTRUCTIONS AND WARNINGS IN THIS MANUAL. BECOME FAMILIAR WITH THE OPERATION AND CONTROLS OF THE AIR COMPRESSOR. KEEP OPERATING AREA CLEAR OF ALL PERSONS, PETS, AND OBSTACLES. KEEP CHILDREN AWAY FROM THE AIR COMPRESSOR AT ALL TIMES. DO NOT OPERATE THE PRODUCT WHEN FATIGUED OR UNDER THE INFLUENCE OF ALCOHOL OR DRUGS. STAY ALERT AT ALL TIMES. NEVER DEFEAT THE SAFETY FEATURES OF THIS PRODUCT. EQUIP AREA OF OPERATION WITH A FIRE EXTINGUISHER. DO NOT OPERATE MACHINE WITH MISSING, BROKEN, OR UNAUTHORIZED PARTS.

GLOSSARY

Become familiar with these terms before operating the unit.

CFM: Cubic feet per minute.

SCFM: Standard cubic feet per minute; a unit of measure of air delivery.

PSIG: Pounds per square inch gauge; a unit of measure of pressure.

Code Certification: Products that bear one or more of the following marks: UL, CUL, ETL, CETL, have been evaluated by OSHA certified independent safety laboratories and meet the applicable Underwriters Laboratories Standards for Safety.

Cut-In Pressure: While the motor is off, air tank pressure drops as you continue to use your accessory.

When the tank pressure drops to a certain low level the motor will restart automatically. The low pressure at which the motor automatically restarts is called "cut-in" pressure.

Cut-Out Pressure: When an air compressor is turned on and begins to run, air pressure in the air tank begins to build. It builds to a certain high pressure before the motor automatically shuts off, protecting your air tank from pressure higher than its capacity. The high pressure at which the motor shuts off is called "cut-out" pressure.

Branch Circuit: Circuit carrying electricity from electrical panel to outlet.

ACCESSORIES

This unit is capable of powering the following Accessories. The accessories are available through the current Power and Hand Tool Catalog or full-line Sears stores.

Accessories

- In Line Filter
- Tire Air Chuck
- Quick Connector Sets (various sizes)
- Air Pressure Regulators

- Oil Fog Lubricators
- Air Hose: 1/4", 3/8" or 1/2" I.D. in various lengths

Refer to the selection chart located on the unit to select the tools this unit is capable of powering.

DUTY CYCLE

Air compressors should be operated on not more than a 50% duty cycle. This means an air compressor that pumps air more than 50% of one hour is considered misuse, because

the air compressor is undersized for the required air demand. Maximum compressor pumping time per hour is 30 minutes.

ASSEMBLY

Contents of Carton

- 1 - Air Compressor
- 1 - Handle
- 4 - Self Tapping Screw
- 2 - Wheels
- 2 - Shoulder Bolts, 3/8-16
- 2 - Hex Nuts, 3/8-16
- 1 - Rubber Strip

Tools Required for Assembly

- 1 - 9/16" socket or open end wrench
- 1 - 1/2" socket or open end wrench

Unpacking

1. Remove unit from carton and discard all packaging. **NOTE:** Save all parts bags.

Assemble Handle

1. Insert the handle inside the compressor saddle and line up the two bolt holes on each side.
2. Install the four screws, two on each side.
3. Tighten securely.

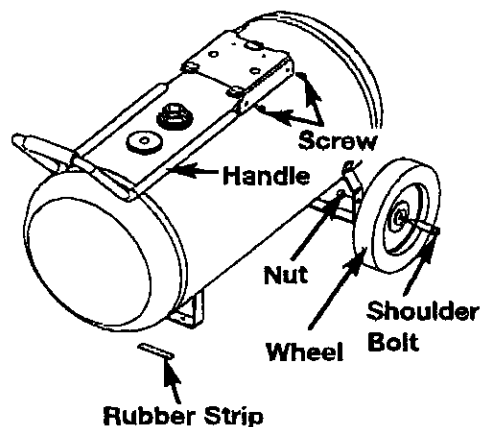

Assemble Wheels

CAUTION It will be necessary to brace or support one side of the air compressor when installing the wheels because the air compressor will have a tendency to tip.

1. Attach wheels with shoulder bolts and nuts as shown.
2. Tighten securely. **NOTE:** The air compressor will sit level if the wheels are properly installed.

CAUTION The wheels and handle do not provide adequate clearance, stability or support for pulling the unit up and down stairs or steps. The unit must be lifted, or pushed up a ramp.

Assemble Rubber Strip

1. Clean and dry underside of air tank leg opposite wheels.
2. Remove the protective paper strip from the adhesive backed rubber foot strip.
3. Attach the rubber foot strip to the bottom of leg. Press firmly into place.

INSTALLATION

HOW TO SET UP YOUR UNIT

Location of the Air Compressor

Locate the air compressor in a clean, dry and well ventilated area. The air compressor should be located at least 12" away from the wall or other obstructions that will interfere with the flow of air. The air compressor pump and shroud are designed to allow for proper cooling. The ventilation openings on the compressor are necessary to maintain proper operating temperature. Do not place rags or other containers on or near these openings. The air filter must be kept clear of obstructions which could reduce air flow to the air compressor.

GROUNDING INSTRUCTIONS

⚠ WARNING RISK OF ELECTRICAL

SHOCK. In the event of a short circuit, grounding reduces the risk of shock by providing an escape wire for the electric current. This air compressor must be properly grounded.

The portable air compressor is equipped with a cord having a grounding wire with an appropriate grounding plug (see following illustrations). The plug must be used with an outlet that has been installed and grounded in accordance with all local codes and ordinances.

1. The cord set and plug with this unit contains a grounding pin. This plug **MUST** be used with a grounded outlet.

IMPORTANT: The outlet being used must be installed and grounded in accordance with all local codes and ordinances.

2. Make sure the outlet being used has the same configuration as the grounded plug. **DO NOT USE AN ADAPTER.** See illustration.

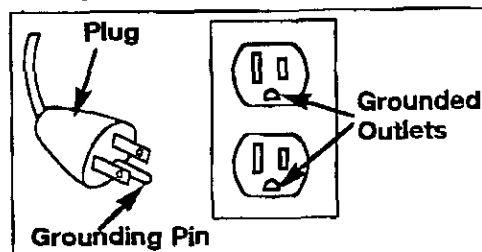

3. Inspect the plug and cord before each use. Do not use if there are signs of damage.
4. If these grounding instructions are not completely understood, or if in doubt as to whether the compressor is properly grounded, have the installation checked by a qualified electrician.

⚠ WARNING IMPROPER GROUNDING CAN RESULT IN ELECTRICAL SHOCK.

Do not modify the plug provided. If it does not fit the available outlet, a correct outlet should be installed by a qualified electrician.

Repairs to the cord set or plug **MUST** be made by a qualified electrician.

Extension Cords

Using extension cords is not recommended. The use of extension cords will cause voltage to drop resulting in power loss to the motor and overheating.

Instead of using extension cords attach extra air hoses to each other starting at the air outlet.

If an extension cord must be used, be sure it is:

- a 3-wire extension cord that has a 3-blade grounding plug, and a 3-slot receptacle that will accept the plug on the product
- in good condition
- no longer than 50 feet
- 12 gauge (AWG) or larger. (Wire size increases as gauge number decreases. 10 AWG and 8 AWG may also be used. DO NOT USE 14 OR 16 AWG.)

Voltage and Circuit Protection

Refer to the specification table for the voltage and minimum branch circuit requirements.

Certain air compressors can be operated on a 15 amp circuit if the following conditions are met.

1. Voltage supply through branch circuit is 15 amps.
2. Circuit is not used to supply any other electrical needs (lights, appliances, etc.).
3. Extension cords comply with specifications.
4. Circuit is equipped with a 15 amp circuit breaker or 15 amp time delay fuse. **NOTE:** If compressor is connected to a circuit protected by fuses, use only time delay fuses. Time delay fuses should be marked "D" in Canada and "T" in the US.

If any of the above conditions cannot be met, or if operation of the compressor repeatedly causes interruption of the power, it may be necessary to operate it from a 20 amp circuit. It is not necessary to change the cord set.

OPERATION

Know Your Air Compressor

READ THIS OWNER'S MANUAL AND SAFETY RULES BEFORE OPERATING YOUR UNIT. Compare the illustrations with your unit to familiarize yourself with the location of various controls and adjustments. Save this manual for future reference.

Description of Operation

Become familiar with these controls before operating the unit.

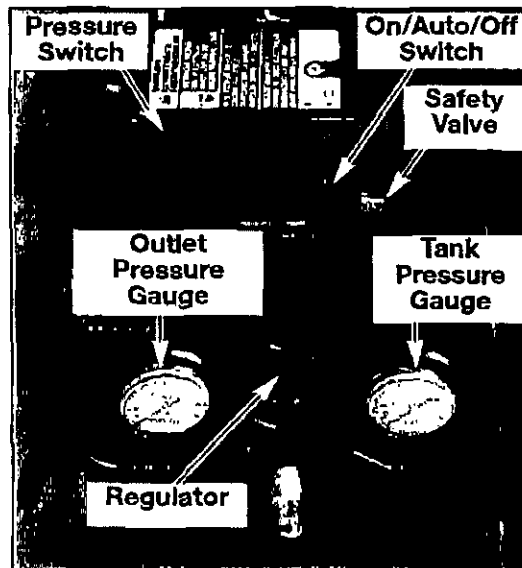

On/Auto/Off Switch: Turn this switch ON to provide automatic power to the pressure switch and OFF to remove power at the end of each use.

Pressure Switch: The pressure switch automatically starts the motor when the air tank pressure drops below the factory set "cut-in" pressure. It stops the motor when the air tank pressure reaches the factory set "cut-out" pressure.

Safety Valve: If the pressure switch does not shut off the air compressor at its "cut-out" pressure setting, the safety valve will protect against high pressure by "popping out" at its factory set pressure (slightly higher than the pressure switch "cut-out" setting).

Outlet Pressure Gauge: The outlet pressure gauge indicates the air pressure available at the outlet side of the regulator. This pressure is controlled by the regulator and is always less than or equal to the tank pressure.

Tank Pressure Gauge: The tank pressure gauge indicates the reserve air pressure in the tank.

Regulator: Controls the air pressure shown on the outlet pressure gauge. Pull the knob out and turn clockwise to increase pressure and counterclockwise to decrease pressure. When the desired pressure is reached push knob in to lock in place.

Drain Valve:

The drain valve is located at the base of the air tank and is used to drain condensation at the end of each use.

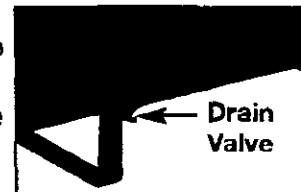

Cooling System (not shown): This compressor contains an advanced design cooling system. At the heart of this cooling system is an engineered fan. It is perfectly normal for this fan to blow air through the vent holes in large amounts. You know that the cooling system is working when air is being expelled.

Air Compressor Pump (not shown): Compresses air into the air tank. Working air is not available until the compressor has raised the air tank pressure above that required at the air outlet.

Check Valve: When the air compressor is operating, the check valve is "open", allowing compressed air to enter the air tank. When the air compressor reaches "cut-out" pressure, the check valve "closes", allowing air pressure to remain inside the air tank.

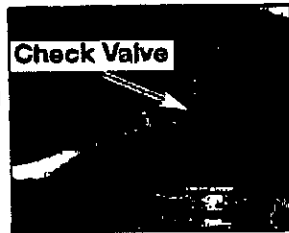

Pressure Release Valve: The pressure release valve located on the side of the pressure switch, is designed to automatically release compressed air from the compressor head and the outlet tube when the air compressor reaches "cut-out" pressure or is shut off. The pressure release valve

allows the motor to restart freely. When the motor stops running, air will be heard escaping



from this valve for a few seconds. No air should be heard leaking when the motor is running or after the unit reaches "cut-out" pressure.

Air Intake Filter (not shown): This filter is designed to clean air coming into the pump. This filter must always be clean and ventilation openings free from obstructions. See "Maintenance".

Motor Overload Protector: The motor has an automatic reset thermal overload protector. If the motor overheats for any reason, the overload protector will shut off the motor. The motor must be allowed to cool down before restarting. The compressor will automatically restart after the motor cools.

If the overload protector shuts the motor off frequently, check for a possible voltage problem. Low voltage can also be suspected when:

1. The motor does not get up to full power or speed.
2. Fuses blow out when starting the motor; lights dim and remain dim when motor is started and is running.

How to Use Your Unit

How to Stop:

1. Set the On/Auto/Off lever to "OFF".

Before First Start Up:

⚠ WARNING Serious damage may result if the following break-in instructions are not closely followed.

This procedure is required **before** the air compressor is put into service and when the check valve or a complete compressor pump has been replaced.

1. Make sure the On/Auto/Off lever is in the "OFF" position.

NOTE: If quick connect is installed, pull coupler back until it clicks to prevent air from escaping through the quick connect.

2. Plug the power cord into the correct branch circuit receptacle. (Refer to Voltage and Circuit Protection paragraph in the Installation section of this manual.)
3. Open the drain valve fully (counterclockwise) to permit air to escape and prevent air pressure build up in the air tank during the break-in period.

NOTE: Always drain tank on a washable surface or in a suitable container to prevent damaging or staining surfaces.

4. Move the On/Auto/Off lever to "ON/AUTO" position. The compressor will start.
5. Run the compressor for 15 minutes. Make sure the drain valve is open and there is minimal air pressure build-up in tank.
6. After 15 minutes, close the drain valve (clockwise). The air receiver will fill to "cut-out" pressure and the motor will stop.

The compressor is now ready for use.

Before Each Start-Up:

1. Place On/Auto/Off lever to "OFF".
2. Pull regulator knob out, turn counterclockwise until it stops. Push knob in to lock in place.
3. Attach hose and accessories.
NOTE: The hose or accessory will require a quick connect plug if the air outlet is equipped with a quick connect.

⚠ WARNING Too much air pressure causes a hazardous risk of bursting. Check the manufacturer's maximum pressure rating for air tools and accessories. The regulator outlet pressure must never exceed the maximum pressure rating.

How to Start:

1. Turn the On/Auto/Off lever to "AUTO" and allow tank pressure to build. Motor will stop when tank pressure reaches "cut-out" pressure.
2. Pull the regulator knob out and turn clockwise to increase pressure. When the desired pressure is reached push knob in to lock in place. The compressor is ready for use.

NOTE: Always operate the air compressor in well-ventilated areas free of gasoline or other combustible vapors. If the compressor is being used to operate a sprayer DO NOT place near the spray area.

MAINTENANCE

Customer Responsibilities

	Before each use	Daily or after each use	Every 40 hours	Every 100 hours	Yearly
Check Safety Valve	●				
Drain Tank		●			
Air Filter			●(1)	●	
Air compressor pump intake and exhaust valves					●
1- more frequent in dusty or humid conditions					

⚠ WARNING Unit cycles automatically when power is on. When performing maintenance, you may be exposed to voltage sources, compressed air, or moving parts. Personal injuries can occur. Before performing any maintenance or repair, disconnect power source from the compressor and bleed off all air pressure.

To ensure efficient operation and longer life of the air compressor outfit, a routine maintenance schedule should be prepared and followed. The following routine maintenance schedule is geared to an outfit in a normal working environment operating on a daily basis. If necessary, the schedule should be modified to suit the conditions under which your compressor is used. The modifications will depend upon the hours of operation and the working environment. Compressor outfits in an extremely dirty and/or hostile environment will require a greater frequency of all maintenance checks.

NOTE: See "Operation" section for the location of controls.

To Check Safety Valve

⚠ WARNING If the safety valve does not work properly, over-pressurization may occur, causing air tank rupture or an explosion.

1. Before starting compressor, pull the ring on the safety valve to make sure that the safety valve operates freely. If the valve is stuck or does not operate smoothly, it must be replaced with the same type of valve.

To Drain Tank

1. Set the On/Auto/Off lever to "OFF".
2. Pull the regulator knob out and turn clockwise to set the outlet pressure to zero.
3. Remove the air tool or accessory.
4. Pull ring on safety valve allowing air to bleed from the tank until tank pressure is approximately 20 psi. Release safety valve ring.
5. Drain water from air tank by opening drain valve (counter-clockwise) on bottom of tank.

⚠ WARNING Water will condense in the air tank. If not drained, water will corrode and weaken the air tank causing a risk of air tank rupture.

6. After the water has been drained, close the drain valve (clockwise). The air compressor can now be stored.

NOTE: If drain valve is plugged, release all air pressure. The valve can then be removed, cleaned, the reinstalled.

Air Filter - Inspection and Replacement

⚠WARNING Hot surfaces. Risk of burn. Air Compressor heads are exposed when filter cover is removed. Allow compressor to cool prior to servicing.

A dirty air filter will not allow the compressor to operate at full capacity. Keep the air filter clean at all times.

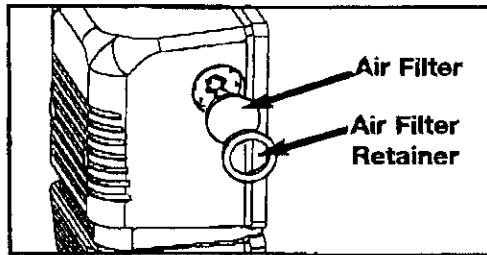

1. Remove the air filter retainer.
2. Remove the air filter and make sure it is clean.

IMPORTANT: Do not operate the compressor with the air filter removed.

3. If dirty, rinse air filter with warm water and squeeze dry.
4. Replace air filter and air filter retainer.

NOTE: If the air filter is extremely dirty it will need to be replaced. Refer to the "Repair Parts" for the correct part number.

Air Compressor Pump Intake and Exhaust Valves

Once a year have a Trained Service Technician check the air compressor pump intake and exhaust valves.

SERVICE AND ADJUSTMENTS

⚠ WARNING Unit cycles automatically when power is on. When doing Maintenance, you may be exposed to voltage sources, compressed air or moving parts. Personal injuries can occur. Before performing any Maintenance or repair, unplug the compressor and bleed off all air pressure.

ALL MAINTENANCE AND REPAIR OPERATIONS NOT LISTED MUST BE PERFORMED BY A TRAINED SERVICE TECHNICIAN.

- ⚠ WARNING** Before servicing:
- Unplug or disconnect electrical supply to the air compressor.
 - Bleed tank of pressure.
 - Allow the air compressor to cool.

To Replace or Clean Check Valve

1. Release all air pressure from air tank. See "To Drain Tank" in the Maintenance section.
2. Unplug air compressor.
3. Remove shrouds.
4. Using an adjustable wrench, loosen outlet tube nut at air tank and pump. Carefully move outlet tube away from check valve.

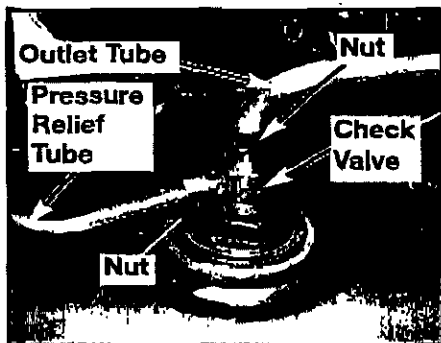

5. Using an adjustable wrench, loosen pressure relief tube nut at air tank and pressure switch. Carefully move pressure relief tube away from check valve.

6. Unscrew the check valve (turn counterclockwise) using a 7/8" open end wrench. **Note** the orientation for reassembly.
7. Using a screwdriver, carefully push the valve disc up and down. **NOTE:** The valve disc should move freely up and down on a spring which holds the valve disc in the closed position; if not the check valve needs to be cleaned or replaced.

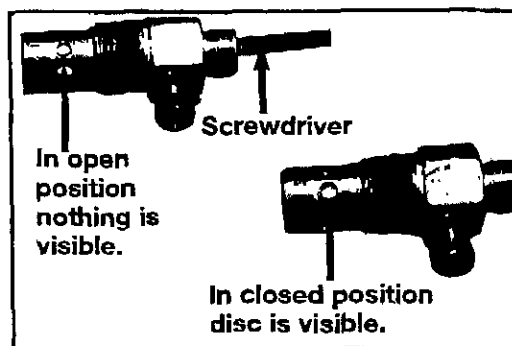

8. Clean or replace the check valve. A solvent, such as paint or varnish remover can be used to clean the check valve.
9. Apply sealant to the check valve threads. Reinstall the check valve (turn clockwise).
10. Replace the pressure release tube. Tighten nuts.
11. Replace the outlet tube and tighten nuts.
12. Replace shrouds.
13. Perform the Break-in Procedure. See "Break-in Procedure" in the Operation section.

To Replace Regulator

1. Release all air pressure from air tank. See "To Drain Tank" in the Maintenance section.
2. Unplug air compressor.
3. Remove the regulator ring and remove the console cover.

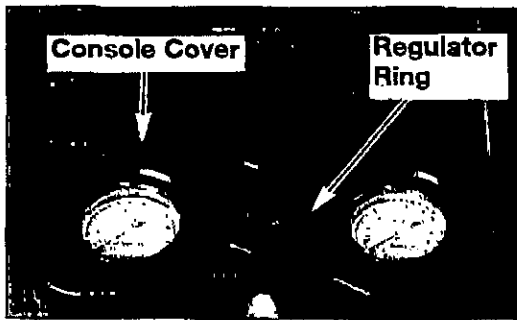

4. Remove the outlet pressure gauge, tank pressure gauge, and quick connect (if equipped) from the regulator.
5. Remove the regulator.

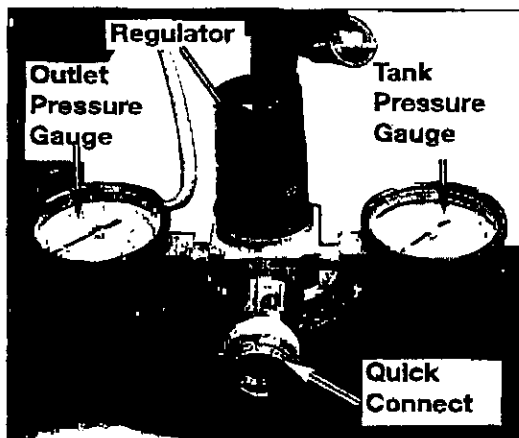

6. Apply pipe sealant tape to the nipple.
7. Assemble the regulator and orient as shown.

NOTE: Arrow indicates flow of air. Make sure it is pointing in the direction of air flow.

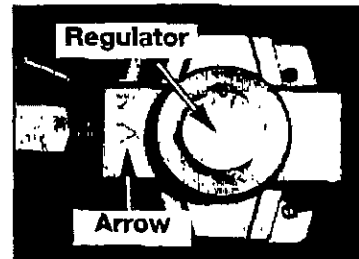

8. Reapply pipe sealant to outlet pressure gauge and quick connect.
9. Reassemble outlet pressure gauge, tank pressure gauge, and quick connect. Orient outlet pressure gauge and tank pressure gauge to read correctly. Tighten quick connect with wrench.
10. Replace console cover and regulator ring.

STORAGE

Before you store the air compressor, make sure you do the following:

1. Review the "Maintenance" section on the preceding pages and perform scheduled maintenance as necessary.
2. Set the On/Auto/Off lever to "OFF".
3. Turn the regulator counterclockwise and set the outlet pressure to zero.
4. Remove the air tool or accessory.
5. Pull ring on safety valve allowing air to bleed from the tank until tank pressure is approximately 20 psi. Release safety valve ring.
6. Drain water from air tank by opening drain valve on bottom of tank.

⚠ WARNING Water will condense in the air tank. If not drained, water will corrode and weaken the air tank causing a risk of air tank rupture.

7. After the water has been drained, close the drain or drain valve.

NOTE: If drain valve is plugged, release all air pressure. The valve can then be removed, cleaned, then reinstalled.

8. Protect the electrical cord and air hose from damage (such as being stepped on or run over). Wind them loosely around the compressor handle.

Store the air compressor in a clean and dry location.

TROUBLESHOOTING

⚠ WARNING Performing repairs may expose voltage sources, moving parts or compressed air sources, moving parts or compressed air sources. Personal injury may occur. Prior to attempting any repairs, unplug the air compressor and bleed off all air tank air pressure.

PROBLEM	CAUSE	CORRECTION
Excessive tank pressure - safety valve pops off.	Pressure switch does not shut off motor when compressor reaches "cut-out" pressure.	Move On/Auto/Off lever to the "OFF" position, if the outfit does not shut off contact a Trained Service Technician.
	Pressure switch "cut-out" too high.	Contact a Trained Service Technician.
Air leaks at fittings.	Tube fittings are not tight enough.	Tighten fittings where air can be heard escaping. Check fittings with soapy water solution. Do Not Overtighten.
Air leaks at or inside check valve	Check valve seat damaged.	A defective check valve results in a constant air leak at the pressure release valve when there is pressure in the tank and the compressor is shut off. Replace check valve. Refer to the "To Replace or Clean Check Valve" in the "Service and Adjustment" section.
Air leaks at pressure switch release valve.	Defective pressure switch release valve.	Contact a Trained Service Technician.
Air leaks in air tank or at air tank welds.	Defective air tank.	Air tank must be replaced. Do not repair the leak. ⚠ WARNING Do not drill into, weld or otherwise modify air tank or it will weaken. The tank can rupture or explode.
Air leaks between head and valve plate.	Leaking seal.	Contact a Trained Service Technician.

PROBLEM	CAUSE	CORRECTION
Pressure reading on the regulated pressure gauge drops when an accessory is used.	It is normal for "some" pressure drop to occur.	<p>If there is an excessive amount of pressure drop when the accessory is used, adjust the regulator following the instructions in the "Description of Operation" paragraph in the "Operation Section."</p> <p>NOTE: Adjust the regulated pressure under flow conditions (while accessory is being used).</p>
Knocking Noise.	<p>Possible defect in safety valve.</p> <p>Defective check valve.</p>	<p>Operate safety valve manually by pulling on ring. If valve still leaks, it should be replaced.</p> <p>Remove and clean, or replace.</p>
Compressor is not supplying enough air to operate accessories.	<p>Prolonged excessive use of air.</p> <p>Compressor is not large enough for air requirement.</p> <p>Hole in hose.</p> <p>Check valve restricted.</p> <p>Air leaks.</p> <p>Restricted air intake filter</p>	<p>Decrease amount of air usage.</p> <p>Check the accessory air requirement. If it is higher than the SCFM or pressure supplied by your air compressor, you need a larger compressor.</p> <p>Check and replace if required.</p> <p>Remove and clean, or replace.</p> <p>Tighten fittings.</p> <p>Clean or replace air intake filter. Do not operate the air compressor with the filter removed. Refer to the "Air Filter" paragraph in the "Maintenance" section.</p>
Regulator knob has continuous air leak.	Damaged regulator	Replace

PROBLEM	CAUSE	CORRECTION
Regulator will not shut off air outlet.	Damaged regulator	Replace
Motor will not run.	<p>Motor overload protection switch has tripped</p> <p>Tank pressure exceeds pressure switch "cut-in" pressure.</p> <p>Extension cord is wrong length or gauge.</p> <p>Check valve stuck open.</p> <p>Loose electrical connections.</p> <p>Possible defective motor or starting capacitor.</p> <p>Paint spray on internal motor parts.</p> <p>Pressure release valve on pressure switch has not unloaded head pressure.</p> <p>Fuse blown, circuit breaker tripped.</p>	<p>Let motor cool off and overload switch will automatically reset.</p> <p>Motor will start automatically when tank pressure drops below "cut-in" pressure of pressure switch.</p> <p>Check for proper gauge wire and cord length.</p> <p>Remove and clean, or replace.</p> <p>Check wiring connection inside pressure switch and terminal box area.</p> <p>Have checked by a Trained Service Technician.</p> <p>Have checked by a Trained Service Technician. Do not operate the compressor in the paint spray area. See flammable vapor warning.</p> <p>Bleed the line by pushing the lever on the pressure switch to the "off" position; if the valve does not open, replace switch.</p> <ol style="list-style-type: none"> 1. Check fuse box for blown fuse and replace as necessary. Reset circuit breaker. Do not use a fuse or circuit breaker with higher rating than that specified for your particular branch circuit. 2. Check for proper fuse. You should use a time delay fuse. 3. Check for low voltage conditions and/or proper extension cord. 4. Disconnect the other electrical appliances from circuit or operate the compressor on its own branch circuit.

AIR COMPRESSOR DIAGRAM

Air Compressor Model Number 919.165180

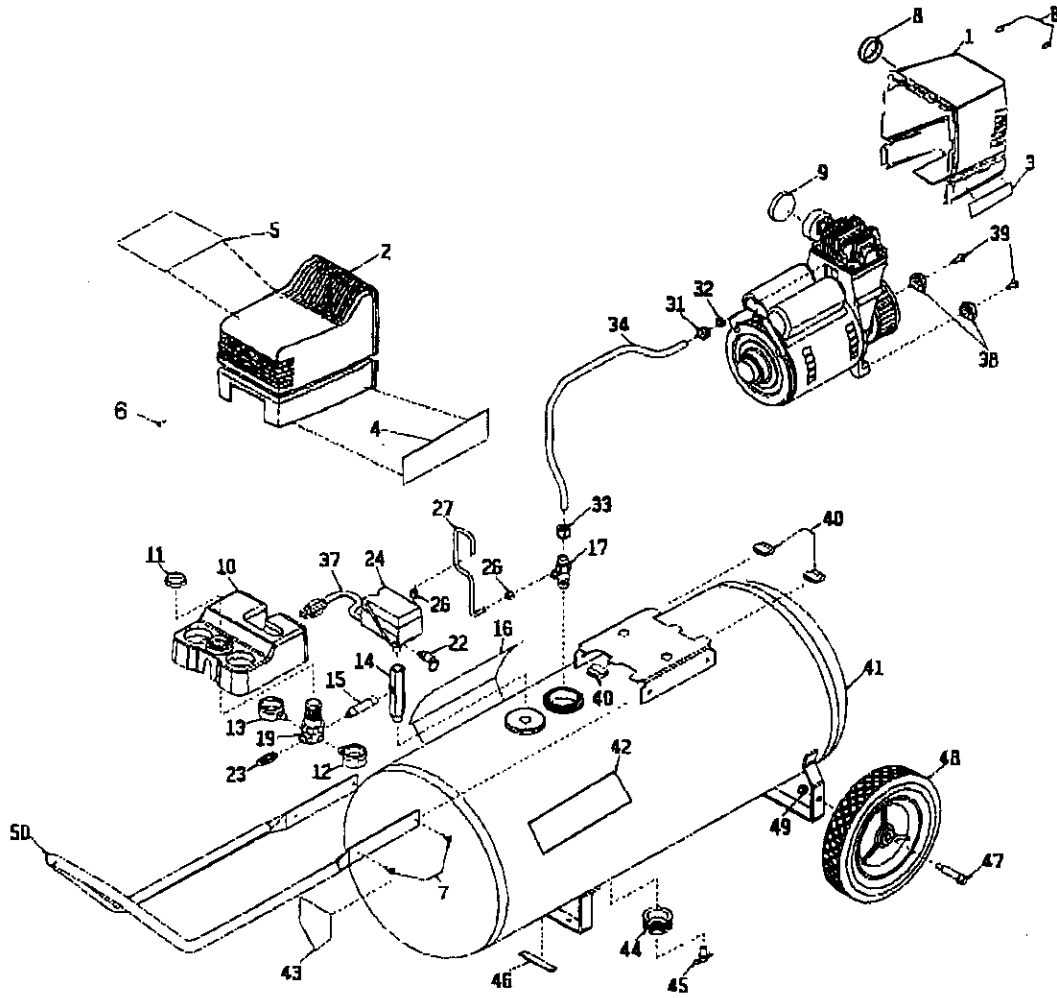

PARTS LIST

Air Compressor Model Number 919.165180

KEY	NO.	PART NO.	DESCRIPTION
	1	CAC-1317	Front Shroud
	2	AC-0029	Rear Shroud
	3	LA-3367	Label, Performance
	4	D24584	Label, Billboard
	5	LA-3162	Label, Maintenance
	6	ACG-408	Fastener Assembly (3 used-Torque 15-25 in.-lbs.)
	7	SSF-981	Screw Hex Head Self Tapping (4 used)
+	8	CAC-1373	Filter Retainer
+	9	CAC-1372	Foam Filter
	10	AC-0012	Console
	11	CAC-61	Ring, Panel Mounting
	12	Z-AC-0009-1	Gauge, Right Hand
	13	Z-AC-0010-1	Gauge, Left Hand
	14	AC-0027-2	Manifold
	15	SSP-480	Nipple, 1/4 x 2.5"
	16	LA-3021	Label, Warning
	17	AC-0631	Check Valve
	19	AC-0007	Regulator
	22	97503734	Safety Valve
	23	H-2101	Adapter
	24	Z-AC-0758	Pressure Switch
	26	SSP-7811	Nut Sleeve Assembly 1/4" (2 used)
	27	AC-0028	Pressure Relief Tube
	31	SSP-7821-1	Compression Nut (Torque 100-120 in.-lbs.)
	32	SSG-3105	O-Ring
	33	SSP-7813	Nut Sleeve Assembly 3/8"
	34	AC-0097	Outlet Tube
	37	SUDL-413-2	Cord Assembly
	38	ACG-18	Cap, Saddle Mount (2 used)
	39	91895680	Screw, 1/4-20 x .75" (2 used- Torque 9-12 ft.-lbs.)
	40	ACG-19	Isolator (3 used)
	41	Z-D22655	Tank, 25 Gallon
	42	LA-3069	Label, Craftsman
	43	LA-3027	Label, Drain Tank
	44	SSP-470-1	Hex Reducer Bushing
	45	SS-2707	Drain Valve
	46	SUDL-6-1	Strip, Rubber Foot
	47	CAC-60	Shoulder Bolt (2 used)
	48	D23138	Wheel (2 used)
	49	SSF-8080-ZN	Hex Nut 3/8" (2 used)
	50	AC-0564	Handle

AIR COMPRESSOR PUMP DIAGRAM

Air Compressor Model Number 919.165180

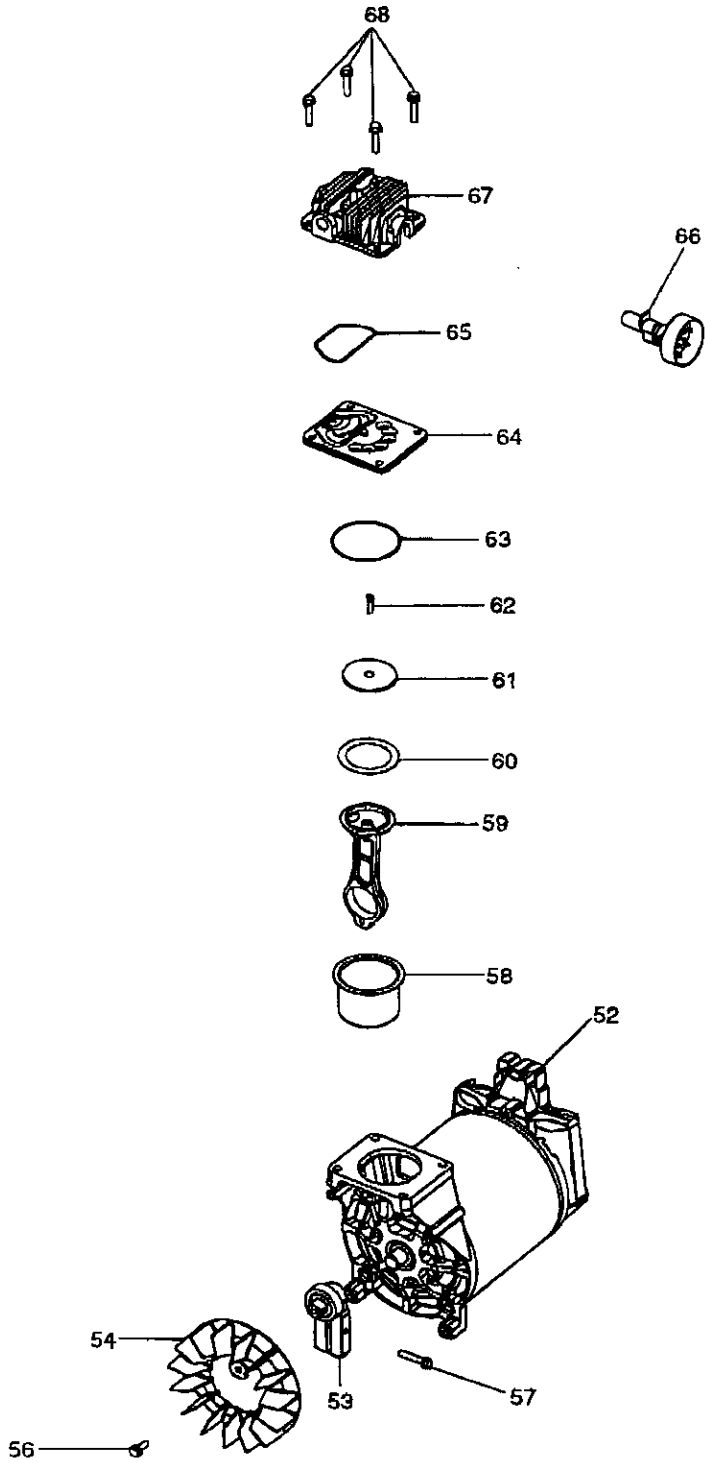

PARTS LIST

Air Compressor Model Number 919.165180

KEY NO.	<u>PART NUMBER</u>	<u>DESCRIPTION</u>
52	Z-D23360	Motor
53	Z-AC-0140	Eccentric Bearing
54	AC-0108	Fan
56	SSF-586	Screw 1/4-20 UNC x .75"
57	SSF-615	Screw 1/4-20 UNC x 1.25"
>x58	-----	Cylinder Sleeve
> 59	-----	Connecting Rod Assembly
>x60	DAC-308	Formed Compression Ring
> 61	ACG-29	Connecting Rod Cap
>x62	SSF-3158-1	Screw 10 - 24 x .75", T25 (2 used)
>x63	SSG-8156	O-Ring
64	Z-AC-0032	Valve Plate Assembly
>x65	ACG-45	O-Ring
66	CAC-1371	Muffler
67	AC-0037	Head
68	SSF-927	Screw 1/4-20 x 1.125" THD (4 used)
<u>Not Illustrated</u>		
	D24580	Owners Manual
x	K-0650	Compression Ring Kit
>	KK-4835	Connecting Rod Kit
+	KK-5041	Muffler/Foam Kit