

RCA

USER'S GUIDE



videocassette recorder videocasset
te recorder videocassette recorder v
ideocassette recorder videocassett
erecorder videocassette recorder vi
deocassette recorder videocassette
recorder videocassette recorder vid
eocassette recorder videocassette r
ecorder videocassette recorder vide
ocassette recorder videocassette r
corder videocassette recorder video
cassette recorder videocassette rec
order videocassette recorder videoc
assette recorder videocassette reco
rdervideocassette recorder videocas
ssetterecorder videocassette recor
dervideocassette recorder videocas
setterecorder videocassette recorder
ervideocassette recorder videocass
etterecorder videocassette recorder
rvideocassette recorder videocasse
tterecorder videocassette reco
rdervideocassette recorder vide
ocassette recorder
videocassette recorder
ecorder
oeca
ett
cor
vide
sse
e

A black and white photograph of two dogs. On the left is a small, light-colored dog, possibly a Chihuahua or similar breed. On the right is a larger, white dog with black spots and floppy ears, likely a Weimaraner. Both dogs are looking towards the camera.

SAFETY INFORMATION

WARNING

To reduce risk of fire or shock hazard, do not expose this product to rain or moisture.

WARNING

RISK OF ELECTRIC SHOCK
DO NOT OPEN

TO REDUCE THE RISK OF ELECTRIC SHOCK, DO NOT REMOVE COVER (OR BACK). NO USER SERVICEABLE PARTS INSIDE. REFER SERVICING TO QUALIFIED SERVICE PERSONNEL.



This symbol indicates important instructions accompanying the product.



This symbol indicates "dangerous voltage" inside the product that presents a risk of electric shock or personal injury.

Cautions

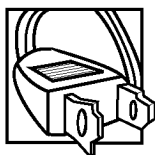

Caution: To reduce the risk of electric shock, match the wide blade of the power cord to the wide slot in the AC outlet. Be sure to insert the plug completely.

Attention: Pour éviter les chocs électriques, introduire la lame la plus large de la fiche dans la borne correspondante de la prise et pousser jusqu'au fond.

Refer to the identification/rating label located on the back panel of your product for its proper operating voltage.

FCC Regulations state that unauthorized changes or modifications to this equipment may void the user's authority to operate it.

Cable TV Installer: This reminder is provided to call your attention to Article 820-40 of the National Electrical Code (Section 54 of the Canadian Electrical Code, Part 1) which provides guidelines for proper grounding and, in particular, specifies that the cable ground shall be connected to the grounding system of the building as close to the point of cable entry as practical.

Care and Cleaning:

Use a soft cloth or the dusting attachment of your vacuum cleaner to dust your VCR. Remove dust from both top and bottom ventilation holes.

Plastic surfaces are easily scratched and can be marred by alcohol and various solvents. Avoid excessive use of oil-based furniture polishes since the materials used in the cabinet will accumulate more dust. A nonabrasive, antistatic cleaner/polisher is recommended.

Product Registration

Please fill out the product registration card and return it immediately. Returning the card allows us to contact you if needed.

Keep your sales receipt to obtain warranty parts and service and for proof of purchase. Attach it here and record the serial and model numbers in case you need them. The numbers are located on the back of the receiver.

Model No. VR352

Serial No. _____

Purchase Date: _____

Dealer/Address/Phone: _____

TABLE OF CONTENTS

First Things First	3
Setting Up the VCR	7
Using the Menu to Set Up Features	8
Language Selection	8
Cable Box Setup	9
VCR Channels List	10
To Auto Channel Search	10
To Change the Signal Type	11
To Add or Remove Channels	12
Time and Date	12
Set Daylight-Saving Time	12
Set the Time and Date	13
VCR Plus+ Channels	14
VCR Plus+ Worksheet	15
Additional Set-up Features in the Preferences Menu	16
Remote VCR1/VCR2 Option	16
Auto Play	17
EnergySaver	17
Front Panel Brightness (VCR Display)	18
Preferred Tape Speed	18
VCR Basics	19
Remote Buttons	20
Component Buttons	20
VCR Function Buttons	20
TV Function Buttons	21
Playing a Tape	22
Automatic Rewind	23
Tape Eject	23
Recording	23
Check the Safety Tab	23
Recording	25
Recording Features	26
Express Recording (XPR)	26
Timer Recording	27
Timer Recording with VCR Plus+	28
Setting Up the Channel List	28
Using VCR Plus+ Programming Codes	28
Stopping a Timer Recording	30
Reviewing and Clearing Programs	30
Using Two VCRs for Copying and Editing Tapes	31

TABLE OF CONTENTS

Program the Remote	33
About Programming the Remote	34
Programming the Remote to Control a TV	34
Operate the TV	34
TV Codes	35
Other Features	37
Picture Search Options	38
Forward and Reverse Search	38
Commercial Scan (Search Button)	38
Frame Advance	38
Index Search	39
Go-To Search	40
Pro-Tect Plus™ Locking Feature	40
Tracking	41
Time Counter	41
On-screen Displays	42
Things to Know Before Connecting Components	43
Connections	43
Connecting Your VCR	44
Jacks and Cables	44
RF Jacks and Coaxial Cables (F-type)	44
Audio/Video Jacks and Cables (RCA-type)	44
Choosing a VCR Connection	45
Advantages of Audio/Video Cable Connections ..	45
TV with RF Jack Only	46
TV with Audio/Video Jacks	47
TV with Audio/Video Jacks and Cable Box to Unscramble Pay Channels Only	48
Reference	49
Front Panel	50
Clock/Counter Display	51
Back Panel	52
How to Find Your TV's Video Input Channel	53
Troubleshooting Tips	54
Specifications	57
Cleaning the VCR	57
Limited Warranty	58
Index	59

FIRST THINGS FIRST

WELCOME TO YOUR NEW VCR...

To help you get started using your VCR with as little reading possible, we've put all the basic information needed in the first three sections. To help you along, there's even an initial set-up feature the first time you turn on your VCR which walks you through several set up steps at once.

GETTING STARTED

Before this first step, though, learning about the time and date, your remote control's features, working with channels, and basic video tape operations are essential to get all you can out of the VCR. Once you are comfortable with these features, feel free to refer to other sections because they cover the more detailed information.

WHAT REMAINS?

The final sections of this manual contain playback and recording information, a detailed connections section, and a reference section including troubleshooting tips, warranty information, and an index.

1 FIRST THINGS FIRST



2 SETTING UP THE VCR



3 VCR BASICS



4 RECORDING



5 PROGRAM THE REMOTE



6 OTHER FEATURES



7 CONNECTIONS



8 REFERENCE

READ ME!

These note boxes give you tips for your new video cassette recorder.

FIRST THINGS FIRST

STEP 1: WHAT'S IN THE BOX?

The following items come packed in the box:

- VCR
- Remote control
- RF coaxial cable

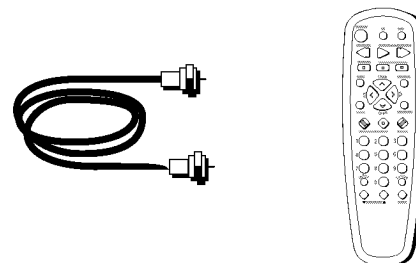
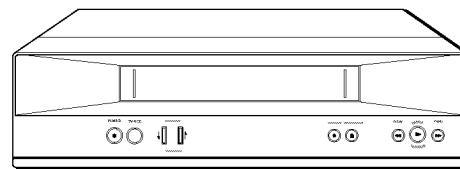

STEP 2: INSTALL BATTERIES IN THE REMOTE CONTROL

Follow these steps whenever you need to install or change the batteries in your VCR remote.

1. Remove the cover of the battery compartment.
2. Place the batteries into the remote's back panel. Match the positive (+) and negative (-) ends of each battery to the diagram inside the battery compartment.
3. Replace the cover.

STEP 3: CONNECT YOUR VCR

If you connect your VCR to your home antenna or cable system and then to your TV, use the VCR's ANT IN and RF OUT jacks for a good signal as shown to the right.

If you have a TV with AUDIO/VIDEO jacks, use the jacks for a better connection. Refer to the section, *Connections*, toward the back of the manual, for additional connection options.

STEP 4: PLUG IN THE VCR

Your VCR's power cord has a plastic band strung through the blades. **Remove plastic band before plugging the cord into the power outlet.** To remove band, cut with a pair of scissors and pull it free of the blades. Once the plastic is removed, match the wide blade of the power cord to the wide slot in the AC outlet. Be sure to insert the plug completely.

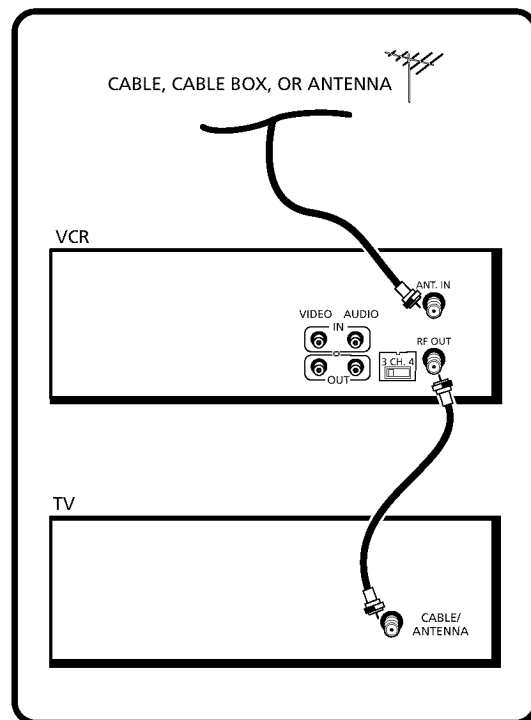

FIRST THINGS FIRST

STEP 5: TUNE THE TV

Tune the TV to the VCR viewing channel. The VCR viewing channel is channel 3 or 4 or the TV's video input.

- If you connect your VCR using the ANTENNA connectors with RF coaxial cable, set the 3 CH. 4 switch to channel 3 or channel 4 — the channel you want to use on your TV.
- If you connect your VCR using the AUDIO/VIDEO jacks with audio/video cables, select the TV's video input with the remote control's INPUT button to see the signal. If you have trouble understanding the VIDEO INPUT CHANNEL, look to page 53 for more information.

STEP 6: TURN ON THE VCR

Press POWER on the VCR's front panel or the VCR button on the remote control to turn on the VCR. The first time you turn the VCR on, a menu screen appears. This is the start of an interactive set up which helps you select specific features of your VCR. You can cancel out of this initial set up once you are past the first screen (see next step), but this process walks you through a series of screens reducing the time needed to program your VCR.

STEP 7: INITIAL SETUP

The first on-screen menu during the initial set up asks which language you prefer to use for your VCR. Use the remote control's number buttons to select options.

1. Press 1 for English, 2 for Español (Spanish), or 3 for Français (French).

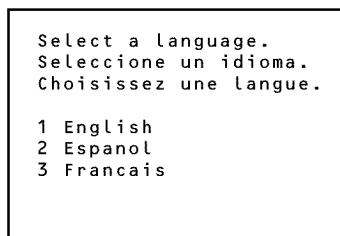

The remaining menus throughout the set up will appear in the chosen language. Follow the on-screen instructions to complete the initial set up process.

VCR Viewing Channel

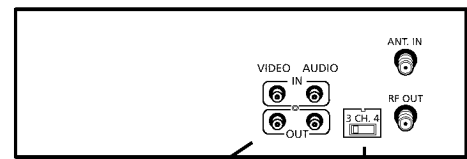

A/V input/output jacks

Channel 3/4 switch

When using the ANT IN and RF OUT jacks to connect your VCR, tune your TV to channel 3 or 4.

The 3-4 switch on the back of the VCR determines which TV channel is used to see VCR output.

When using the AUDIO/VIDEO jacks to connect your VCR, tune your TV to the TV's video input channel with the INPUT button on your remote control. For more information about selecting your video input channel, see page 53.

FIRST THINGS FIRST

STEP 8: ACCESSING MENUS

The MENU and number buttons let you access, select, and change your VCR's preferences individually. For example, to select a different preferred on-screen language than the one selected during the initial set up, do the following:

1. Press MENU to display the VCR MAIN MENU.

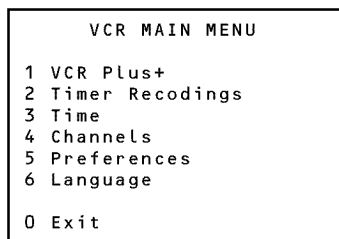

2. Press 6 to display the LANGUAGE menu.

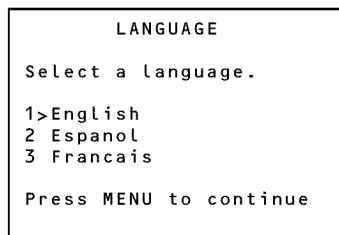

3. On the remote control, press one (1) for English, two (2) for Spanish, and three (3) for French.

All other on-screen menus are worked with in similar ways using the remote control to follow on-screen instructions. See *Additional Set-Up Features* in the next section for detailed information about accessing menus.

NEXT SECTION: LEARNING THE MENUS OF YOUR VCR

Now that you understand how to move around through menus, go to the next section to set up individual menus of your VCR.

SETTING UP THE VCR

ON-SCREEN GUIDE AND ADDITIONAL SET-UP FEATURES

Below is a list of features that need to set up before using your VCR for the first time. Many of these menus are covered during the initial set up, but if you ever want to change a menu, refer to this section.

- Language
- Cable Box Set Up
- VCR Channel List (Auto Channel Search)
- Daylight-Saving Time and Time Zone
- Time and Date
- VCR Plus+ Channels
- Remote VCRI/VCR2
- Auto Play
- EnergySaver
- Front Panel Brightness
- Preferred Tape Speed

1 FIRST THINGS FIRST



2 SETTING UP THE VCR



3 VCR BASICS



4 RECORDING



5 PROGRAM THE REMOTE



6 OTHER FEATURES



7 CONNECTIONS



8 REFERENCE

SETTING UP THE VCR

USING THE MENU TO SET UP FEATURES

You can set up your VCR's features by using the remote control's buttons to enter your choices from on-screen instructions. Each menu item is explained in this section. For each numbered selection on the menus, use the same numbered button on the remote control to select it.

LANGUAGE SELECTION

If you did not complete this step in the previous section during the initial set up, it is time to select your preferred language. Once this step is complete, all on-screen displays will appear in that language.

1. On your remote control, press the MENU button to display the VCR MAIN MENU.

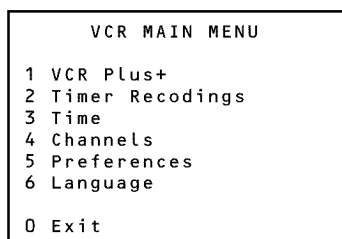

2. Press 6 to select the LANGUAGE menu.

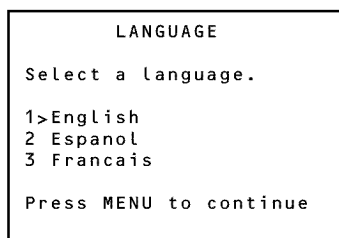

3. Select 1) English, 2) Español (Spanish), or 3) Français (French) by pressing the appropriate number on the remote control's key pad. An arrow indicates the selection you've made. Once you have made your choice, press MENU on the remote to continue back to the MAIN MENU screen.

Is Something Missing?

Not all the VCR screens will always be shown in this manual when explaining the features.

SETTING UP THE VCR

CABLE BOX SETUP

This set up applies **only** when all channels are received through a cable box. In this case, the VCR will automatically enter the channel used to view cable box programming. Your VCR will use this channel for all future timer recordings.

1. Press MENU to display the VCR MAIN MENU.

```
VCR MAIN MENU
1 VCR Plus+
2 Timer Recodings
3 Time
4 Channels
5 Preferences
6 Language
0 Exit
```

2. Press 4 to display the CHANNELS menu.

```
CHANNELS
1 Auto Channel Search
2 Add/Remove Channels
3 Signal Type: CABLE
4 VCR Plus+ Channel list
5 Cable Box Setup
0 Exit
```

3. Press 5 to display CABLE BOX SETUP. Then select one of the three choices.

```
CABLE BOX SETUP
Do you use your cable
box to receive ALL
channels or only SOME
Channels?
1 ALL channels
2 Only SOME channels
3 Cancel setup
```

4. If you selected ALL CHANNELS, enter the output channel of your cable box (usually 03 or 04), or press the INPUT button on your remote control for video line input if you use AUDIO/VIDEO jacks.

```
CABLE BOX SETUP
On what channel does
the VCR receive signals
from the cable box?
(usually 3, 4, or Video)
--
Enter 01-13 or INPUT
Press MENU to cancel
```

Cable Box Setup

ALL channels: enter two numbers for output channel of your cable box or press INPUT if you connect your cable box with AUDIO/VIDEO jacks.

Only SOME channels: if you only use the cable box to tune premium channels.

Cancel setup: select to cancel.

SETTING UP THE VCR

```
CABLE BOX SETUP
On what channel does
the VCR receive signals
from the cable box?
(usually 3, 4 or video)

04

Press CLEAR to correct
Press MENU to continue
```

5. Once you complete the setup, the VCR confirms that the VCR will now receive all signals on the designated channel. For example:

```
CABLE BOX SETUP

The VCR will now
receive all signals
from the cable box
on channel 04.

Press MENU to continue
```

VCR CHANNELS LIST

If you use a cable box for *all channels*, this step is not necessary. Your VCR may come with a channel list preset at the factory, but you may want to add or delete some channels depending on whether they are active.

Auto Channel Search

1. Press MENU to display the VCR MAIN MENU.

```
VCR MAIN MENU

1 VCR Plus+
2 Timer Recodings
3 Time
4 Channels
5 Preferences
6 Language

0 Exit
```

2. Press 4 to display the CHANNELS menu.

Auto Channel Search

Use the Auto Channel Search feature to place all available channels in memory.

If you ever change cable or antenna signals, you may need to Auto Channel Search again.

SETTING UP THE VCR

```
CHANNELS
1 Auto Channel Search
2 Add/Remove Channels
3 Signal Type: CABLE
4 VCR Plus+ Channel List
5 Cable Box Setup

0 Exit
```

3. Press 1 to display the AUTO CHANNEL SEARCH menu.

```
AUTO CHANNEL SEARCH
What type of signal
are you using?
1 Cable TV
2 Antenna
3>Detect Automatically

0 Cancel
```

4. Select one of the three AUTO CHANNEL SEARCH options, your choice will be marked with an arrow symbol at the left:
 - *Cable TV* searches for cable channels
 - *Antenna* searches for local broadcast stations
 - *Detect Automatically* will make this decision for you

```
AUTO CHANNEL SEARCH

Now scanning channel 14

Press any key to cancel
```

The VCR begins scanning for the available channels—this takes a few minutes. When the scan is complete, the VCR tunes to the lowest channel number. At this point, pressing CHAN up or down should only select the active channels.

Changing the Signal Type

1. Press MENU to display the VCR MAIN MENU.
2. Press 4 to display the CHANNELS menu.
3. Press 3 to change the Signal Type between CABLE and ANTENNA.

Detect Automatically

A strong cable or antenna signal in your area may cause Auto Detect to mis-detect. If this should happen, select 1 or 2 for the system you have.

Selecting Channels

The CHANNEL up and down buttons access those channels active in your VCR channel list.

You can still access channels not in the channel list by using the number.

SETTING UP THE VCR

Adding or Removing Channels

You may want to add or remove channels after you Auto Channel Search, especially if some of the channels have weak signals or you don't want to watch them.

1. Press MENU to display the VCR MAIN MENU.
2. Press 4 to display the CHANNELS menu.
3. Press 2 to display the ADD/REMOVE CHANNELS screen. Use CHAN up or down or number buttons to go to the channels you want to remove or add.

```
ADD/REMOVE CHANNELS

Channel 115
is presently ADDED

Press CLEAR to remove
Press MENU to exit
```

```
ADD/REMOVE CHANNELS

Channel 115
is presently REMOVED

Press INFO to add
Press MENU to exit
```

4. Follow the on-screen instructions to finish this set up.

TIME AND DATE

Before you set the time and date, set the Auto DST (Daylight-Saving Time) feature to ON or OFF for your area.

Setting Daylight-Saving Time

1. Press MENU to display the VCR MAIN MENU.

```
VCR MAIN MENU

1 VCR Plus+
2 Timer Recodings
3 Time
4 Channels
5 Preferences
6 Language

0 Exit
```

2. Press 3 to display the TIME menu.

Spring forward; Fall backward

In the Spring, daylight-saving time begins on the first Sunday in April. Because the clock automatically changes from 2:00 AM to 3:00 AM (forward one hour), remember to include the extra hour for timer recording falling within this time frame.

In the Autumn, daylight-saving time ends on the last Sunday in October. The VCR clock automatically changes from 2:00 AM to 1:00 AM (back one hour). Therefore, it can affect your recording length.

SETTING UP THE VCR

```
TIME
1 Set Time and Date
2 Auto DST:      ON
0 Exit
```

3. Press 2 to switch between AUTO DST ON or OFF.

 - Select ON if you want the VCR's clock to automatically adjust for daylight-saving time.
 - Select OFF if you do not want the VCR's clock to adjust for daylight-saving time.

Setting the Time and Date

1. Press MENU to display the VCR MAIN MENU.
2. Press 3 to display the TIME menu.
3. Press 1 to display the SET TIME AND DATE menu.

```
SET TIME AND DATE
Time --:--
      (hh:mm)
Date --/--/--
Press MENU to cancel
```

4. Enter the data using the number buttons. Press 0 before single-digit numbers and follow the on-screen directions.

```
SET TIME AND DATE
Time 12:34 PM
Date 11/18/97 Tuesday
Press CLEAR to correct
Press MENU to set
```

Time/Date Display

Pressing INFO on the remote displays the time and date on the screen.

SETTING UP THE VCR

VCR Plus+ CHANNELS

Using VCR Plus+ can make programming timer recordings for cable or off-air antenna easier, but you have to put in a little time right now to set up a channel list. A worksheet and abbreviated codes for typical cable services in the U.S. and Canada are provided.

1. Press MENU to display the VCR MAIN MENU.

```
VCR MAIN MENU
1 VCR Plus+
2 Timer Recordings
3 Time
4 Channels
5 Preferences
6 Language
0 Exit
```

2. Press 4 to display the CHANNELS menu.

```
CHANNELS
1 Auto Channel Search
2 Add/Remove Channels
3 Signal Type: CABLE
4 VCR Plus+ Channel List
5 Cable Box Setup
0 Exit
```

3. Press 4 to display the VCR Plus+ Channel List screen.

```
VCR+ Channel My Channel
5 --
4 --
3 -> -> -> --
2 --
1 --

Use CH+/- to select
Press 0-9 to change
Press MENU to save
```

4. Enter the data following the on-screen directions using your worksheet.

```
VCR+ Channel My Channel
5 46
4 --
3 -> -> -> 23
2 --
1 --

Use CH+/- to select
Press 0-9 to change
Press MENU to save
```

Two-Digit VCR Plus+ Channel Numbers for Cable TV (USA List)

35	American Movie Classics
39	Arts &-Entertainment
57	Black Entertainment
54	Bravo
42	Cable News Network
45	Cinemax
98	Cinemax 2
37	The Discovery Channel
53	The Disney Channel
63	Entertainment Television
34	ESPN Sports Network
47	The Family Channel
33	Home Box Office
95	Home Box Office 2
96	Home Box Office 3
51	The Learning Channel
46	Lifetime
58	The Movie Channel
48	Music Television
49	The Nashville Network
38	Nickelodeon
64	Nostalgia Television
99	Quality Value Cable
41	Showtime
97	Showtime 2
59	Sports Channel
52	Turner Network Television
44	USA-Network
62	Video Hits 1
93	Viewer's Choice 1
94	Viewer's Choice 2
55	WGN Chicago
43	WTBS Atlanta
60	WWOR-New York

See next page for Canadian List

VCR Plus+ Channel List

Refer to your local television list for a complete VCR Plus+ channel list for your viewing area or contact your cable company. Using the list may save you some time.

Screen is for an example only.

SETTING UP THE VCR

ADDITIONAL SET-UP FEATURES IN THE PREFERENCES MENU

The features in this section are all accessed through the PREFERENCES menu.

1. Press MENU to display the VCR MAIN MENU.

```
VCR MAIN MENU
1 VCR Plus+
2 Timer Recodings
3 Time
4 Channels
5 Preferences
6 Language
0 Exit
```

2. Press 5 to display the PREFERENCES menu.

```
PREFERENCES
1 Remote Control: VCR1
2 Auto Play: ON
3 EnergySaver: 2:00
4 Front Panel: AUTO
5 Tape Speed: SLP
0 Exit
```

Now you are ready to select a category from the menu to set up.

REMOTE VCR1/VCR2 OPTION

If you own a compatible RCA, GE, or ProScan remote that has a VCR2, VCR2•LD, or VCR2•DVD button, this feature allows you to set this VCR to respond to that button.

Press 1 to select the Remote Control item. Then press the VCR2, VCR2•LD, or VCR2•DVD button to change.

<pre>PREFERENCES (PRESS VCR2 TO CHANGE) 2 Auto Play: OFF 3 EnergySaver: 2:00 4 Front Panel: AUTO 5 Tape Speed: SLP 0 Exit</pre>	<pre>PREFERENCES 1 Remote Control: VCR2 2 Auto Play: OFF 3 EnergySaver: 2:00 4 Front Panel: AUTO 5 Tape Speed: SLP 0 Exit</pre>
---	---

Remote Control Option

Changing the remote option to VCR2 disables the remote that came with your VCR.

SETTING UP THE VCR

The VCR only responds to a compatible remote control's VCR2, VCR2•LD, or VCR2•DVD button. If you change the remote setting to VCR2, the remote that came with your VCR will no longer control it.

Use the compatible remote to change the remote setting back to VCR1. Display the PREFERENCES menu, press 1, and then press VCR on the VCR's remote.

AUTO PLAY

This feature allows the VCR to automatically start playing when you insert a tape with the safety tab removed. Press 2 to switch between ON or OFF.

- Select ON if you want a tape with its safety tab removed to start playing automatically when the tape is inserted.
- Select OFF if you *do not* want a tape with its safety tab removed to start playing automatically.

ENERGYSAVER

By default, this VCR automatically turns off after two hours of inactivity. Press 3 to change the time delay, or to disable the feature.

- OFF: The VCR will remain turned on until you shut it off.
- 1:00, 2:00, or 3:00: The VCR turns off after one, two, or three hours of inactivity.

Thirty seconds before shutting off, the VCR will warn you with a screen reading, "The VCR will turn off in 30 seconds. Press any key to cancel."

If you use the VCR's tuner instead of your TV to tune channels, you may want to turn this feature off.

PREFERENCES	
1 Remote Control:	VCR1
2 Auto Play:	ON
3 EnergySaver:	2:00
4 Front Panel:	AUTO
5 Tape Speed:	SLP
0 Exit	

The PREFERENCES menu allows you to access settings for your remote control, EnergySaver and front panel brightness options.

Auto Play

For a tape to be able to start playing automatically, it must have the safety tab removed. All rented movies and purchased movies should have this tab removed.

SETTING UP THE VCR

FRONT PANEL BRIGHTNESS (VCR DISPLAY)

You can change the brightness level of the fluorescent display panel on the front of the VCR. Press 4 on the remote control repeatedly to switch between the options.

- AUTO brightens the display when the VCR is on and dims the display when the VCR is off.
- BRIGHT keeps the display bright.
- DIM keeps the display at a low brightness level.

PREFERRED TAPE SPEED

You can set the preferred tape speed. Press 5 repeatedly to switch between the options.

- SP sets the preferred recording speed to SP.
- SLP sets the preferred recording speed to SLP.

PREFERENCES	
1 Remote Control:	VCR1
2 Auto Play:	ON
3 EnergySaver:	2:00
4 Front Panel:	AUTO
5 Tape Speed:	SLP
0 Exit	

The PREFERENCES menu allows you to access settings for your front panel brightness feature.

Tape Speeds

SP (Standard Play)

Gives the best quality recording, but fewer programs can be recorded on the tape. Special effects such as pause, slow motion, picture search, and frame advance work well when you play back tapes recorded in this speed.

SLP (Super Long Play)

Gives three times the recording time of tapes recorded in SP. Special effects such as pause, slow motion, picture search, and frame advance work well when you play back tapes recorded in this speed.

Recording Time:

Cassette	SP	SLP
T-120	2Hr	6Hr
T-160	2Hr	8Hr

VCR BASICS

LEARN THE BASICS TO GET YOU STARTED

These VCR basics should be enough for you to begin enjoying your VCR. Learning the remote control functions, playing a recorded tape, and recording a program should do just that.

This section shows you the basics of using your VCR. It discusses things like using the remote control, playing a tape, and recording programs.

1 FIRST THINGS FIRST



2 SETTING UP THE VCR



3 VCR BASICS



4 RECORDING



5 PROGRAM THE REMOTE



6 OTHER FEATURES



7 CONNECTIONS



8 REFERENCE

VCR Basics tells you what you need to know in order to watch a movie or tape your favorite show.

VCR BASICS

REMOTE BUTTONS

The remote control is capable of controlling your VCR and many brands of televisions. If you have an RCA, ProScan, or GE TV, you may be able to control it without having to program the remote.

COMPONENT BUTTONS

ON•OFF Controls power of VCR when remote is set to control the VCR. Controls power of the TV when the remote is set to control the TV. This button can also turn some compatible components on and off if the remote is programmed.

TV Turns on a compatible RCA, ProScan, or GE TV and sets the remote to control the TV. Also used with the OFF button to turn on or off a different brand of TV (if programmed) and sets the remote to control the TV.

VCR Turns on a compatible RCA, ProScan, or GE VCR and sets the remote to control the VCR.

VCR FUNCTION BUTTONS

CHAN Up or Down Selects next higher or lower channel in the VCR's channel memory.

CLEAR Resets time counter to 0:00:00. Allows you to change entries when setting the clock or a timer recording.

F ADV Lets you view one frame with each press of the button when tape is in pause.

FORWARD Fast forwards the tape when the VCR is stopped. Searches forward through a tape during playback. Starts slow motion during play-pause and increases slow-motion speed.

GO BACK Switches between two channels. Select one channel and then select another using the number buttons. Press GO BACK to switch between the two channels.

INFO Shows the status displays on the TV screen.

INPUT Selects between the line input and the VCR's tuner. Line input refers to the signal coming from the component connected to the AUDIO/VIDEO IN jacks on the back of the VCR. For more information about VIDEO INPUT, see page 53.

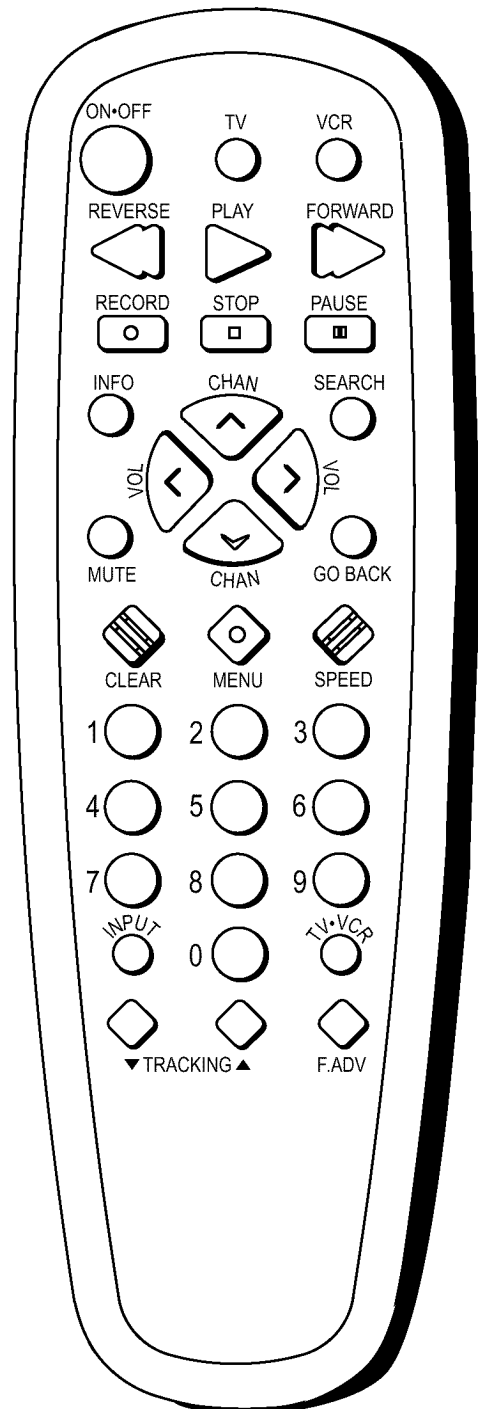

VCR BASICS

MENU Brings up VCR MAIN MENU on the TV screen.

Numbers (0 through 9) Select a channel up to 99 by pressing two numbers. Select a cable channel over 99 by pressing and holding 1 until 1 -- appears on the screen. Then press the other two numbers.

ON•OFF Controls power of the VCR when the remote is set to control the VCR. Controls power of other components if the remote is programmed.

PAUSE Pauses playback or recording. Press PAUSE again to return to playback or recording.

PLAY Plays a tape.

RECORD Starts VCR recording. Also used for express recording.

REVERSE Rewinds the tape when the VCR is stopped. Searches backward through a tape during playback. Starts slow motion during play-pause and decreases slow-motion speed.

SEARCH Displays Index and Go-To Search menus on TV screen when VCR is stopped. Advances the tape 30 seconds of recorded material during playback. Each press advances the tape an additional 30 seconds up to five minutes.

SPEED Selects a recording speed (SP or SLP).

STOP Stops the current VCR function such as record, playback, rewind, or fast forward. Also ejects the tape if held for three seconds while the tape is in stop mode.

TRACKING Up or Down Lets you manually reduce the streaks that may appear on the picture during play, slow motion, or pause. Reduces picture "jitter" during stop-action playback.

TV•VCR Switches the picture signal so that it either comes from the VCR or the cable/antenna system.

TV FUNCTION BUTTONS

CHAN Up or Down Selects next higher or lower channel in the TV's channel memory.

CLEAR Removes menus or status displays from the screen.

GO BACK Switches between two channels. Select one channel and then select another using the number buttons. Press GO BACK to switch between the two channels.

TV Buttons

The TV buttons may not control all features on the model of TV you have.

VCR BASICS

INFO Shows the TV's status displays on the TV screen.

MUTE Reduces volume to minimum level.

Numbers (0 through 9) Select a channel up to 99 by pressing two numbers. Select a cable channel over 99 by pressing and holding 1 until 1 -- appears on the screen. Then press the other two numbers.

ON•OFF Controls the power of the TV when the remote is set to control the TV.

VOL Up and Down Raises and lowers sound of TV.

PLAYING A TAPE

1. Tune the TV to your VCR viewing channel (3, 4, or TV's video input).
2. Insert a tape in the VCR.

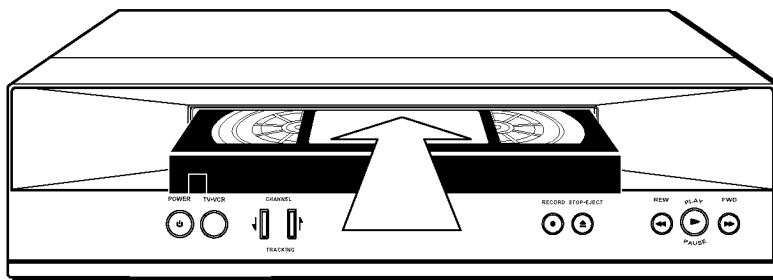

If the Auto Play feature is set to ON, the tape automatically begins playback (if the safety tab on the cassette is removed).

- Press FWD or REV (FORWARD or REVERSE on remote) to position the tape.
- Press PLAY•PAUSE (if necessary) on the VCR (PLAY on remote) to begin tape play.
- Press PLAY•PAUSE (PAUSE on remote) for stop action.
- Press TRACKING up or down to remove any streaks from the picture, if necessary.
- Press STOP•EJECT on VCR (STOP on remote) to stop playback.

If you have trouble getting a picture on the screen, refer to the **INPUT CHANNEL** section on page 53 or the "troubleshooting" section starting on page 54.

Pause

If you pause, the VCR automatically switches from pause to stop after a few minutes to reduce tape wear.

VCR BASICS

AUTOMATIC REWIND

The VCR automatically rewinds the tape if it reaches the end of the tape during playback. While rewinding, you can press POWER and the VCR will turn off after rewinding.

TAPE EJECT

Press STOP•EJECT on the VCR (STOP on remote) when it is stopped to eject the tape.

RECORDING

If you want to record something that you're watching, you can use basic recording. For more detailed information, refer to the "Recording" section of the manual starting on page 25.

1. Set the tape speed by pressing the SPEED button on the remote (see "Tape Speed" in *Setting Up the VCR* section for information about tape speed settings).
2. Press the RECORD button to begin recording.
3. Press STOP to stop recording.

If you just want to pause the recording for a short time (such as during a commercial), press PAUSE instead of STOP.

CHECK THE SAFETY TAB

No matter which recording option you use, you need to make sure there is a tape in the VCR, and that the tape's safety tab is in place. You cannot record on a tape with the safety tab removed.

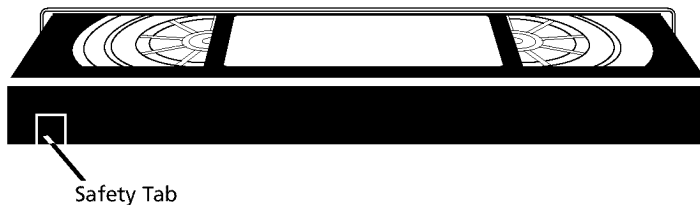

If the safety tab is removed and you want to record over it, simply cover the hole with vinyl tape.

Automatic Tracking

The VCR has automatic tracking which adjusts the picture when playing back a tape recorded on another VCR. Automatic tracking is turned on whenever a tape is inserted or the VCR's power is turned on.

RECORDING

SEVERAL RECORDING OPTIONS

Now that you've gone through the necessary steps to operate your VCR, I'll explain the different recording features that are available.

Recording Features:

- Recording (explained in *VCR Basics* section)
- Express Recording
- Timer Recording
- Timer Recordings with VCR Plus+ Programming System
- Copying and Editing Tapes

1 FIRST THINGS FIRST



2 SETTING UP THE VCR



3 VCR BASICS



4 RECORDING



5 PROGRAM THE REMOTE



6 OTHER FEATURES



7 CONNECTIONS



8 REFERENCE

RECORDING

RECORDING FEATURES

There are four ways to record programs:

- **Recording** lets you press one button to start recording a program (See *VCR Basics* section)
- **Express Recording** lets you start recording a program you are watching, and then set the VCR to automatically stop recording after a designated period of time.
- **Timer Recording** lets you program the VCR to automatically start and stop recording at a predetermined time.
- **Timer Recording with VCR Plus+** lets you program the VCR just by entering a PlusCode number found in TV guides.

EXPRESS RECORDING (XPR)

Use express recording when you want to quickly record the remaining portion of the program you are watching.

1. Set the tape speed by pressing the SPEED button on the remote.
2. Press the RECORD button to begin recording.
3. Repeatedly press the RECORD button to set up the recording duration.

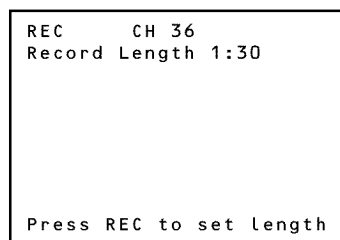
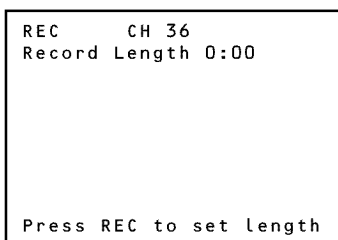

Each time you press the RECORD button, you increase the recording time (up to 4 hours).

The VCR continues to record for the amount of time you indicate, and then automatically turns off.

To stop an express recording, press and hold STOP for three seconds.

Express Recording

Express recording is a great way to tape the last quarter of the game, or the last part of a movie when you have to leave.

RECORDING

TIMER RECORDING

You can set up as many as eight timer recording programs.

1. Press MENU to display the VCR MAIN MENU.

```
VCR MAIN MENU
1 VCR Plus+
2 Timer Recordings
3 Time
4 Channels
5 Preferences
6 Language
0 Exit
```

2. Press 2 to display the TIMER RECORDINGS menu.

```
TIMER RECORDINGS
1 Create a New Program
2 Review Existing Progs.
3 Use VCR PLUS+ Code
0 Exit
```

3. Select 1 to Create a New Program.

```
How often should this
program record?
1 One time
2 Daily (every day)
3 Weekdays (M-F)
4 Weekly (once per week)
0 Cancel
```

4. Select how often you want the program to record.

```
Program 1 (One time)
Channel    --
Start Time ---:--
End Time   ---:--
Start Date --/--/--
Tape Speed SLP
Press MENU to cancel
```

5. Enter the data for the program with the number buttons.

The data includes the channel number (press INPUT to select the line input), start time including AM or PM, and end time. The start date is automatically entered based on the VCR clock. The date and/or speed can be changed when flashing.

Timer Recording Information

The clock must be set correctly.

Insert a tape with the safety tab in place and enough tape to record the program.

PROGRAMS OVERLAP appears if you have entered two programs where the times overlap.

The **TIMER** indicator appears in the display when you turn off the VCR and a timer recording has been set. It flashes if there is no tape in the VCR.

When recording from a cable box or satellite receiver, turn it on and tune it to the channel you want to record before the recording is to begin. The VCR channel should be set to the cable box's output channel, usually Channel 3 or 4.

RECORDING

- Review the information to make sure it is correct, and then press MENU to save.

```

Program 1 (One Time)
Channel      03 Cable
Start Time  08:00 PM
End Time    09:30 PM
Start Date  11/15/99 MON
Tape Speed  SLP
             1=SP 2=SLP
Press CLEAR to correct
Press MENU to save
    
```

```

Program 1 has been saved
Remember to insert a
recordable tape and
turn the VCR off before
the program start time.
Remember to leave your
cable box on and tuned
to the desired channel.
    
```

TIMER RECORDING WITH VCR Plus+

You can use VCR Plus+ to simplify timer programming if you have cable TV and don't receive all channels through a cable box or if you receive your TV signal off-air.

Setting Up the Channel List

If you did not set up the VCR Plus+ programming channel list, you can do it now.

- Display the CHANNELS menu from the VCR MAIN MENU.
- Display the VCR Plus+ Channel List menu.
- Go to *Setting Up Your VCR* if you need more information on setting up your VCR Plus+ channel list.

Using VCR Plus+ Programming Codes

- Press MENU to bring up the VCR MAIN MENU.

```

VCR MAIN MENU
1 VCR Plus+
2 Timer Recodings
3 Time
4 Channels
5 Preferences
6 Language
0 Exit
    
```

- Press 1 to display the VCR Plus+ programming menu.

```

VCR PLUS+
Enter PlusCode Number
(from TV Listing)
-
Press MENU to cancel
    
```

```

VCR MAIN MENU
1 VCR Plus+
2 Timer Recodings
3 Time
    
```

```

CHANNELS
1 Auto Channel Search
2 Add/Remove Channels
3 Signal Type: CABLE
4 VCR Plus+ Channel List
    
```

```

VCR+ Channel My Channel
5          46
4          --
3 -> -> -> 23
2          --
1          --
Use CH+/- to select
Press 0-9 to change
Press MENU to save
    
```

If you receive all channels through your cable box on Channel 3 or 4, you must use the regular Timer Recording method to record programs.

RECORDING

3. Enter the VCR PlusCode shown in your local television programming guide.

```
VCR PLUS+
Enter PlusCode Number
  (from TV listing)
  12876-

Press CLEAR to correct
Press MENU when done
```

4. Press MENU to enter the VCR PlusCode number.

```
How often should this
program record?

1 One time
2 Daily (every day)
3 Weekdays (M-F)
4 Weekly (once per week)

0 Cancel
```

5. Indicate how often you want the program to be recorded.

```
Program 1 (One time)

Channel    03 Cable
Start Time 08:00 PM
End Time   09:30 PM
Start Date 10/24/98 SAT
Tape Speed SLP

Press CLEAR to adjust
Press MENU to save
```

6. Change the speed with the SPEED button on the remote or the program end time with the CLEAR button on the remote (if necessary).

Changing the end time comes in handy when you are recording a program, such as a sporting event, that may exceed the scheduled broadcast time.

7. Press MENU to save the program.

```
Program 1 has been saved

Remember to insert a
recordable tape and
turn the VCR off before
the program start time.

Remember to leave your
cable box on and tuned
to the desired channel.
```

VCR Plus+ Programming Recording

Clock must be set correctly.

Insert a tape with the safety tab in place and enough tape to record the program.

The output of your cable box appears in the Channel item of the timer recording menu if you've set up the VCR for a cable box for all channels. The correct channel and start & stop time will also appear if the VCR is set up to control the cable box.

UNRECOGNIZED NUMBER... PLEASE RE-ENTER appears when the VCR does not recognize the PlusCode number.

PROGRAMS OVERLAP appears if you have entered two programs where the times overlap.

The **TIMER** indicator appears in the display when you turn off the VCR and a timer recording has been set. It flashes if there is no tape in the VCR.

For a cable box the VCR can control, turn it on before the recording is to begin.

For a cable box the VCR cannot control, turn it on and tune it to the channel you want to record before the recording is to begin.

RECORDING

STOPPING A TIMER RECORDING

To stop or cancel a timer recording in progress (even an express recording):

- Press and hold the STOP button for a few seconds.

REVIEWING AND CLEARING PROGRAMS

To review programs that you have already set up:

1. Press MENU to display the VCR MAIN MENU.

```
VCR MAIN MENU
1 VCR Plus+
2 Timer Recordings
3 Time
4 Channels
5 Preferences
6 Language
0 Exit
```

2. Press 2 to displayed to display the TIMER RECORDINGS menu.

```
TIMER RECORDINGS
1 Create a New Program
2 Review Existing Progs.
3 Use VCR Plus+ Code
0 Exit
```

2. Press 2 to display the REVIEW EXISTING PROGS. screen.

```
Program 1 (One time)
Channel 104 Cable
Start Time 12:00 AM
End Time 01:30 AM
Start Date 10/24/97 FRI
Tape Speed SLP
Press CLEAR to erase
Press MENU for next prog
```

3. Press CLEAR to erase items or MENU to see the next program.

RECORDING

USING TWO VCRs FOR COPYING AND EDITING TAPES

Use one VCR as the *playback VCR* and the other as the *recording VCR*.

1. Connect the VCRs using the diagram below.
2. Turn on both VCRs and TV.
3. Tune the TV to the VCR viewing channel (either 3, 4, or TV's video input).
4. If you are using coaxial cables for the connection, tune *recording VCR* to channel 3 or 4—the one selected on the *playback VCR*.

If you are using audio/video cables, select the line input on the *recording VCR*.

5. Insert the tape you want to copy into *playback VCR*. Insert a blank tape with its safety tab in place into *recording VCR*.
6. Using visual search, locate the segment you want to copy on the *playback VCR*. Pause the tape at this location.
7. Press RECORD on the *recording VCR*, then PAUSE.
8. Press PAUSE on both VCRs to begin copying.
9. Press PAUSE on both VCRs to stop copying.
10. Repeat steps 6–9 to copy or edit additional segments.

Caution:

The unauthorized recording of satellite broadcasts, television programs, or other copyrighted materials may infringe the rights of others.

Two VCR Connection

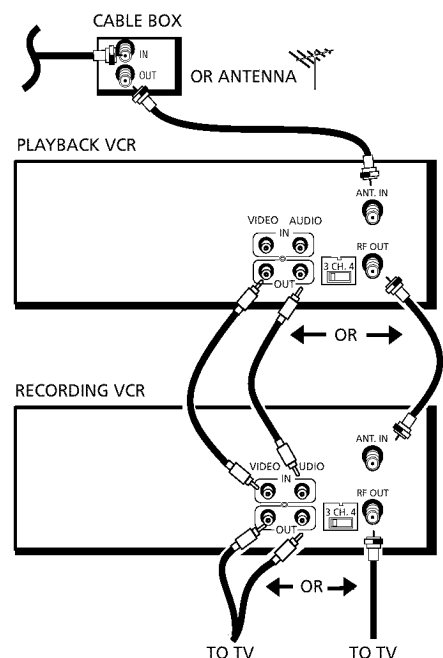

PROGRAM THE REMOTE

CONTROL YOUR TELEVISION

The remote can be programmed to control a television.

It is programmed to control an **RCA, GE, or ProScan TV**. Other manufacturer's brands need to be programmed.

1 FIRST THINGS FIRST



2 SETTING UP THE VCR



3 VCR BASICS



4 RECORDING



5 PROGRAM THE REMOTE



6 OTHER FEATURES



7 CONNECTIONS



8 REFERENCE

PROGRAM THE REMOTE

ABOUT PROGRAMMING THE REMOTE

The remote can be programmed to control other brands or remote controllable TVs, digital satellite receivers, and cable boxes. It is already programmed to operate most RCA, ProScan, and GE televisions and digital satellite receivers.

PROGRAMMING THE REMOTE TO CONTROL A TV

If the TV does not turn on when you press the TV button, the remote needs to be programmed.

Follow these steps to program the remote to control your particular TV:

1. Turn on the TV.
2. Find your TV brand and code number(s) on the code list on the next page.
3. Press and hold the TV button on the remote.
4. Enter the code from the code list.
5. Release TV, and then press CHAN up or down. If the TV responds to the remote commands, the remote is programmed.
6. If the TV does not respond, repeat these steps using the next code listed for your TV's brand

OPERATING THE TV

After you set up the remote, see which buttons operate your TV.

1. Point the remote at the TV, and press the TV button.
If the TV does not turn on, press the TV button and then press the PWR button.
2. You may want to experiment to see which buttons operate your TV. Try pressing buttons, such as VOL and MUTE. See "TV Function Buttons" in the *VCR Basics* Section for details.

This remote may not operate all models of the brands that are shown.

Note the difference between the TV and VCR on-screen displays to see which one the remote is operating.

PROGRAM THE REMOTE

TV Codes

Akai	03	NAD	07
AOC	06,12	NEC	06
Candle	06	Panasonic	04,08,11
Citizen	06	Philco	04,06,12
Colortyme	06	Philips	03,04,06,12
Concerto	06	Pioneer	06
Curtis Mathes	01,06	Portland	06,12
Daewoo	06,12	ProScan	01
Daytron	06	Proton	06
Electrohome	06,12	Quasar	11
Emerson	06	Radio Shack	01,05,13
Envision	05,06	RCA	01,06,12
Fisher	05,08	Realistic	05
GE	00,01,06,11	Sampo	06
Goldstar	06,12	Samsung	06,09,12
Hallmark	06	Sanyo	05,08
Hitachi	06,14	Sears	01,05,06,07, 08,10,12
Infinity	04	Sharp	06,13
J C Penney	00,01,06,09,12	Sony	03
JBL	04	Soundesign	06
Jensen	06	Sylvania	04,06,12
JVC	10,11	Technics	11
Kawasho	03,06	Techwood	06
Kenwood	06,12	Teknika	06
Loewe	04	TMK	06
Luxman	06	Toshiba	05,07,08,09
LXI	04,05,07	Universal	00
Magnavox	04,06,12	Victor	10
Marantz	04,06	Wards	00,01,04,06,12,13
MGA	06,12	Yamaha	12
Mitsubishi	06,12	Zenith	02
MTC	06		

OTHER FEATURES

FEATURES TO ENHANCE VCR OPERATION

- Picture Search Options
- Pro-Tect Plus™ Locking
- Tracking
- Time Counter
- On-Screen Displays

1 FIRST THINGS FIRST



2 SETTING UP THE VCR



3 VCR BASICS



4 RECORDING



5 PROGRAM THE REMOTE



6 OTHER FEATURES



7 CONNECTIONS



8 REFERENCE

OTHER FEATURES

PICTURE SEARCH OPTIONS

The most basic way to search during playback is using the FORWARD (FWD on the VCR) or REVERSE (REV on the VCR) buttons. This section contains several other options available for searching a tape.

FORWARD AND REVERSE SEARCH

You can search a tape during playback. Sound is turned off during picture search. Search works well for tapes recorded at the SLP speed.

1. Press FORWARD (FWD) to search forward or REVERSE (REV) to search in reverse.
2. Press FORWARD (FWD) or REVERSE (REV) again or press PLAY to return to normal playback.

COMMERCIAL SCAN (SEARCH BUTTON)

This is useful for skipping commercials or short program segments.

1. Press SEARCH once during playback to advance the tape approximately 30 seconds of recorded material.
2. Each press of the SEARCH button adds an additional 30 seconds up to five minutes.

FRAME ADVANCE

Frame advance lets you view one-stop action frame after another during playback. Frame advance works well for tapes recorded at the SLP speed.

1. Press PAUSE to “freeze” the action.
2. Press F ADV each time you want to view a frame of the scene.
3. Press PAUSE or PLAY to return to normal playback.

OTHER FEATURES

INDEX SEARCH

The VCR has a "VHS Index Search System" that automatically records an index mark on the tape every time you start a recording.

During playback you can locate the program you want to play by the number of index marks or by scanning. The VCR will search forward or reverse from the location you are on the tape.

To Search:

1. Press STOP.
2. Press SEARCH on the remote to display the INDEX SEARCH menu on the TV screen.
3. If you want to search through a certain number of index marks, press two number buttons to enter the number of marks you want to search. Press CLEAR on the remote to correct an entry.
4. Press FWD to search forward or REV to search in reverse. The VCR will locate your index mark and begin playback. If you did not enter a specific index number, the VCR will locate the next index mark and begin playback.
5. Press STOP to stop index searching.

Some index marks may be missed by the VCR:

- A mark too close to your location on the tape.
- The mark at the beginning of a recorded segment of five minutes or less.
- The first index mark on the tape when you start at the beginning of the tape.

```
INDEX SEARCH
Press REV OR FWD
to begin scanning
OR
enter a specific
index number
--
Press SEARCH to exit
```

```
INDEX SEARCH
Searching for
index number 12...
Press STOP to cancel
```

```
INDEX SEARCH
Searching for
index marks...
Press STOP to cancel
```

OTHER FEATURES

GO-TO SEARCH

The Go-To Search feature enables the VCR to quickly locate a counter reading anywhere on the tape. When the VCR locates the counter reading, it will begin playback.

1. Press STOP.
2. Press SEARCH on the remote until the GO-TO SEARCH menu appears on the screen.
3. Press number buttons to enter the hour(s) and/or minutes of the counter reading you want the VCR to "go to". Press CLEAR on the remote to correct an entry.
4. Press FWD to search forward or REV to search in reverse.
5. Press STOP to stop Go-To searching.

```
GO-TO SEARCH
Current tape counter is
      2:17:25
Press REV or FWD
to go to 0:00:00
Press SEARCH to exit.
```

PRO-TECT PLUS™ LOCKING FEATURE

To disable the usage of the VCR, or to protect your timer recordings, you can lock the VCR so that the buttons on the VCR or remote won't work.

- To Lock: Press and hold either the remote's POWER or OFF button. All lighted digits on the front panel will flash when activated. The digits will also flash if you turn on the VCR when this feature is activated.
- To Unlock the feature and turn on the VCR: Press and hold either the remote's POWER or VCR button for six seconds.

Locking Your VCR

If a timer recording is programmed, make sure your VCR is turned off. Locking your VCR prevents the VCR from being accidentally turned on.

OTHER FEATURES

TRACKING

Your VCR has automatic tracking which removes the streaks or snow from the picture. Automatic tracking is activated when you insert a tape or turn on the VCR. Occasionally you may need to manually adjust tracking, especially if the tape was recorded on a different VCR. Just use the TRACK buttons to remove the streaks or snow. You can also use tracking when you pause a tape to reduce jittering of the picture.

When you manually adjust the picture, automatic tracking is turned off. To turn automatic tracking back on, press both TRACK buttons on the front of the VCR at the same time, or eject the tape and re-insert it. Tracking has no effect during recording—only playback.

TIME COUNTER

The time counter shows the actual time it takes to record a program or play back a segment of a recorded tape. It helps locate the beginning or end of programs you taped. The time counter resets to 0:00:00 whenever the tape is ejected from the VCR.

For example, if you record a 30-minute program at the beginning of the tape and you want to go to the end of that program to begin another recording, you would:

1. Press INFO **twice** to display the time counter.
2. Press CLEAR to reset the time counter to 0:00:00.
3. Press FWD to forward the tape until the time counter reads 0:30:00.
4. Press STOP. This is the approximate end of the program. (You may want to press PLAY to verify.) Now, you can begin recording at this spot.
5. Press INFO twice to remove the time counter from the screen and return to the normal display mode.

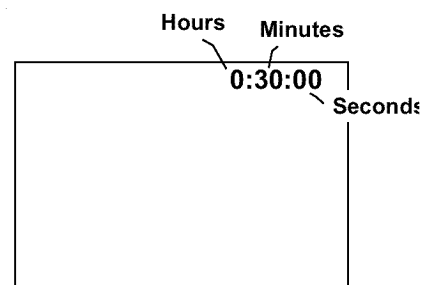

OTHER FEATURES

ON-SCREEN DISPLAYS

The INFO button shows the status of the VCR (STOP, PLAY, RECORD, etc.), channel number, time counter, date, time, and tape speed on the TV screen. The date and time must be set before they can be displayed.

1. Press INFO to see the on-screen displays.
2. Press INFO again to have only the time counter remain on the screen.
3. Press INFO again to have no displays appear on the TV screen. This is useful for dubbing tapes.

Turning off the VCR also resets the displays.

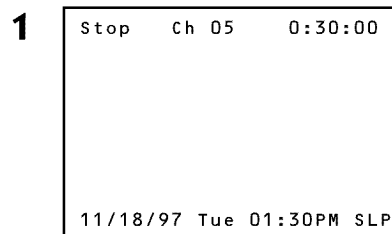

On-screen display (times out)

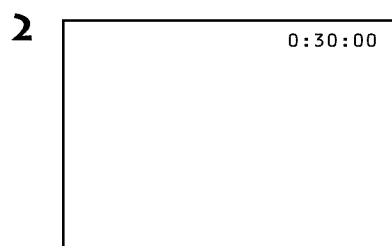

Time counter only (does not time out)



*No displays will appear
(useful for dubbing)*

CONNECTIONS

THINGS TO KNOW BEFORE CONNECTING COMPONENTS

Protect Your Components from Power Surges

- Connect all components before plugging any power cords into the wall outlet.
- Always turn off the TV and other components before you connect or disconnect any cables.

Position Cables Correctly to Avoid Audio Hum or Interference

- Insert all cable plugs firmly into their jacks.
- Place the audio/video cables to the sides of the back panel of the TV instead of straight down the middle after you connect your components.
- Try not to coil any twin-lead cables and keep them away from the audio/video cables as much as possible.
- Make sure all antennas and cables are properly grounded. Refer to the Safety Tips sheet packed with your unit.

Protect Your Components from Overheating

- Do not block ventilation holes in any of the components. Arrange the components so that air can circulate freely.
- Do not stack components.
- Allow adequate ventilation when placing your components in a stand.
- Place an amplifier or satellite receiver on the top shelf of the stand so heated air rising from it will not flow around other components.

1 FIRST THINGS FIRST



2 SETTING UP THE VCR



3 VCR BASICS



4 RECORDING



5 PROGRAM THE REMOTE



6 OTHER FEATURES



7 CONNECTIONS



8 REFERENCE

CONNECTIONS

CONNECTING YOUR VCR

Refer to these pages to help you connect your VCR.

JACKS AND CABLES

RF Jacks and Coaxial Cables (F-type)

The RF jacks provide good picture and mono sound quality, and must be used if audio/video connections are not available for your TV.

These jacks are required for antenna or cable-TV connections. The RF jacks on the VCR are labeled ANT IN and RF OUT. The coaxial cable supplied with your VCR is used to connect the VCR's RF OUT jack and your TV's antenna input.



RF Jack

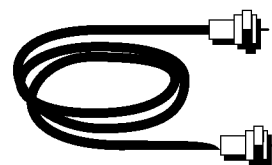

Audio/Video Jacks and Cables (RCA-type)

The AUDIO/VIDEO jacks provide very good picture quality and sound, and can be used if your TV has audio/video input jacks.

These jacks are used for most audio/video connections between components. The VCR AUDIO/VIDEO jacks are color coded (yellow for video, white for audio). If your TV has two inputs for audio (stereo), use the one labeled MONO. Otherwise, you may need a Y-adaptor to hear sound from both channels.



Audio/Video Jack

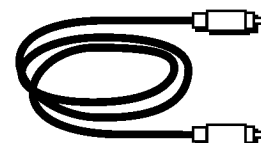

CONNECTIONS

CHOOSING A VCR CONNECTION

There are several different ways to connect your VCR, depending on whether or not you have cable service, and if you have a cable box, and whether some of the channels are scrambled, and maybe you have a satellite receiver along with cable (but no cable box), or a satellite receiver and no cable or... well, you get the picture.

Five connections are described in this section and one of them should provide you with a VCR connection that works.

- TV with RF jack only
- TV with audio/video jacks
- TV with audio/video jacks and cable box to unscramble pay channels only

If you need to connect additional components not shown in the diagrams here (and are unsure of how to connect them), refer to the instruction manual that came with that particular component.

ADVANTAGES OF AUDIO/VIDEO CABLE CONNECTIONS

Using a simple coaxial cable connection gives you good picture quality. If your television has audio/video jacks, I highly recommend using them to get even better picture quality and mono sound when recording and playing back videotapes. These connections give you more convenient operation by not having to share the TV's antenna signal.

CONNECTIONS

TV WITH RF JACK ONLY

This connection assumes:

- You are connecting antenna, cable, or cable box system.
- Your television has only an RF input jack.

This connection provides:

- Mono sound playback from VCR.
- Record one channel while watching another (except when using a cable box for all channels).

To use this connection, you must have:

- one coaxial cable for cable/antenna connection
- coaxial cable for cable box connection.

To connect:

1. Connect cables as shown.
2. Return to *First Things First*, then follow the steps.

Using This Connection

Tune your TV to channel 3 or 4, whichever one you selected with the 3 CH. 4 switch on the back of the VCR.

To play a tape:

1. Insert a tape.
2. If necessary, press PLAY.

To record one program and watch another:

1. Begin recording a program using one of the recording features.
2. Press the TV•VCR button and select a different channel on the TV.

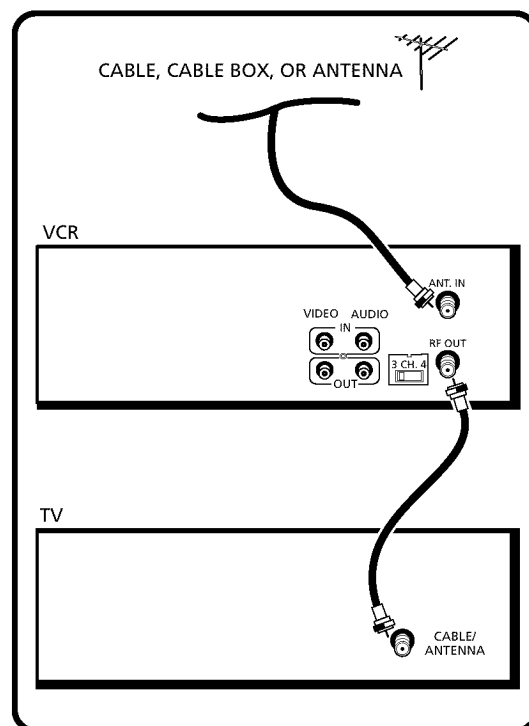

CONNECTIONS

TV WITH AUDIO/VIDEO JACKS

This connection assumes:

- You are connecting an antenna, cable, or cable box system.
- Your television has audio/video jacks.

This connection provides:

- Mono sound playback from VCR.
- Record one channel while watching another (except when using a cable box for all channels).

To use this connection, you must have:

- one coaxial cable for a cable/antenna connection, or two coaxial cables for cable box connection
- two audio/video cables

To connect:

1. Connect cables as shown.
2. Return to *First Things First*, then follow the steps.

Using This Connection

Tune your TV to its video input channel.

To play a tape:

1. Insert a tape.
2. If necessary, press PLAY.

To record one program and watch another:

1. Begin recording a program using one of the recording features.
2. Select a different channel on the TV.

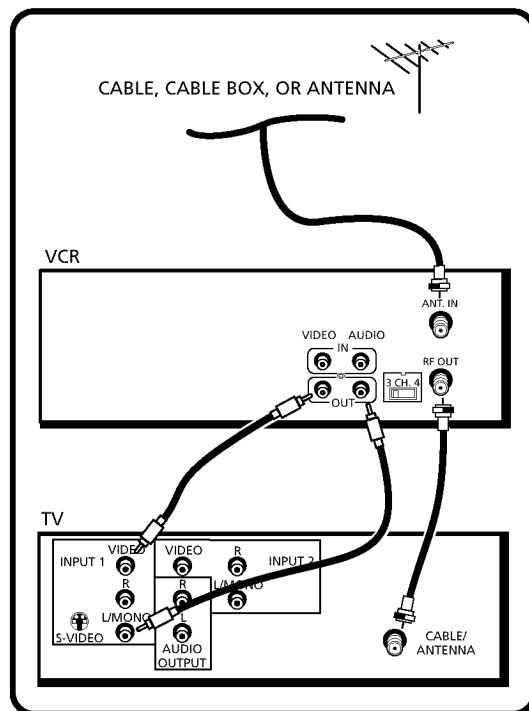

CONNECTIONS

TV WITH AUDIO/VIDEO JACKS AND CABLE BOX TO UNSCRAMBLE PAY CHANNELS ONLY

This connection assumes:

- You are using a cable box only to unscramble premium channels.
- Your TV has audio/video input jacks.

This connection provides:

- Mono sound playback from VCR.
- Recording a scrambled or unscrambled channel through the cable box while watching an unscrambled channel.

To use this connection, you must have:

- (3) coaxial cables
- (2) audio/video cables
- (1) splitter

To connect:

1. Connect cables as shown.
2. Return to *First Things First*, then follow the steps.

Using This Connection

Tune your TV to its video input channel.

To play a tape:

1. Insert a tape.
2. If necessary, press PLAY.

To record a scrambled or unscrambled program and watch another unscrambled program:

1. Begin recording a scrambled or unscrambled program through the cable box using one of the recording features.
2. Select an unscrambled channel on the TV.

All scrambled channels must be viewed through the VCR.

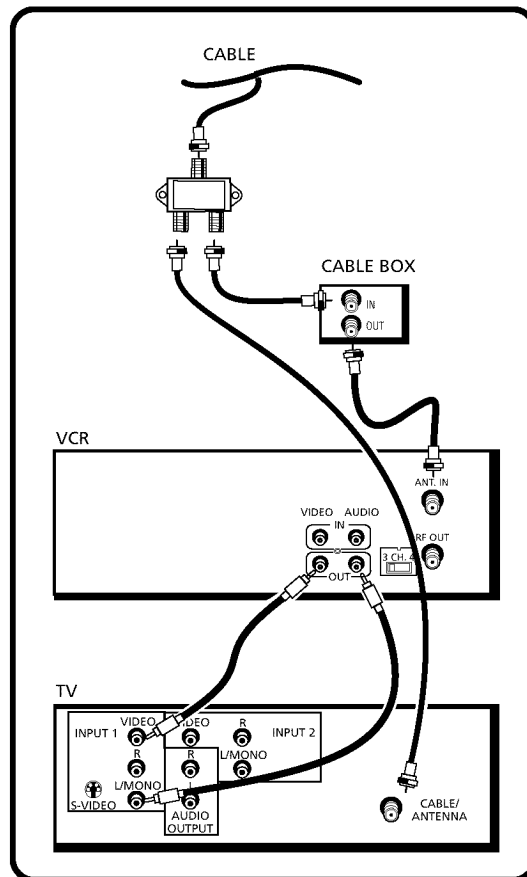

REFERENCE

This section gives you some additional information about the VCR, including a description of the unit's controls and display.

You also will find a *Troubleshooting Tips* section in this Appendix, which might help to resolve some of those simple problems.

Finally, this section contains your warranty information.

1 FIRST THINGS FIRST



2 SETTING UP THE VCR



3 VCR BASICS



4 RECORDING



5 PROGRAM THE REMOTE



6 OTHER FEATURES



7 CONNECTIONS



8 REFERENCE

REFERENCE

FRONT PANEL

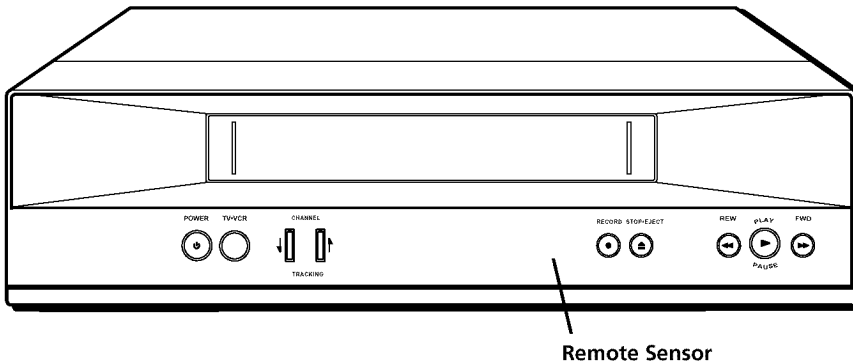

CHANNEL/TRACKING Up or Down Selects next higher or lower channel in the VCR's channel memory. Adjusts tracking when a tape is playing. Press both together to recenter tracking.

FWD Forwards the tape when the VCR is stopped. Searches the picture forward during playback. Starts slow-motion during play-pause and increases slow-motion speed.

PLAY•PAUSE Plays a tape. Pauses action for viewing during playback. Pauses recording to prevent recording of unwanted scenes.

POWER Turns the VCR on or off.

RECORD Starts VCR recording. Used for express recording.

Remote Sensor Receives signals from the remote control. Aim the remote at this sensor.

REW Rewinds the tape when the VCR is stopped. Searches the picture in reverse during playback. Starts slow motion during play-pause and decreases slow-motion speed.

STOP•EJECT Stops the normal functions such as record, playback, rewind, fast-forward, or pause. Ejects the tape when the VCR is stopped.

SPEED Selects a recording speed (SP or SLP)

TV•VCR Switches the picture signal so that it either comes from the VCR or cable/antenna system.

REFERENCE

CLOCK/COUNTER DISPLAY

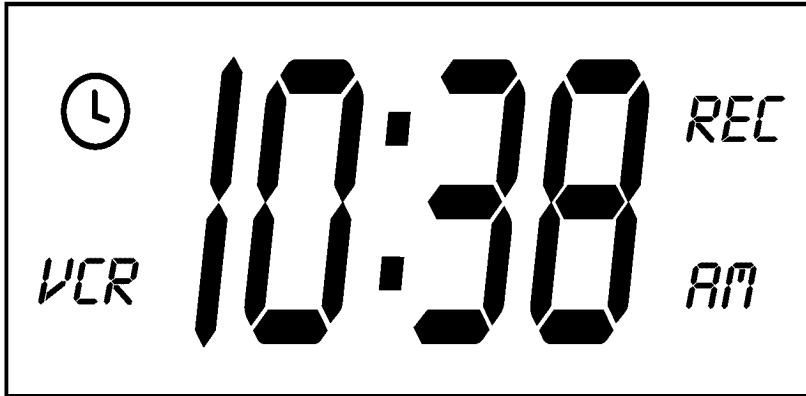

TIME The current time appears. Only an AM indicator appears with the time. There is no indicator for PM.

TIME COUNTER This shows the actual time it takes to play back a segment of a recorded tape. This counter helps locate the beginning or end of programs taped.

REC INDICATOR Lights when the VCR is recording.

TIMER INDICATOR (⌚) Lights during an express or timer recording or when the VCR is set for a timer recording and the VCR is turned off. Flashes when the clock is not set. Flashes when the timer recording is set and there is no tape in the VCR.

VCR INDICATOR (Applies only if the VCR Viewing Channel is 3 or 4.) Press the TV•VCR button on the remote or front VCR panel to turn on or off.

- VCR Indicator on: Picture from VCR
- VCR Indicator off: Picture from the TV channel.

REFERENCE

BACK PANEL

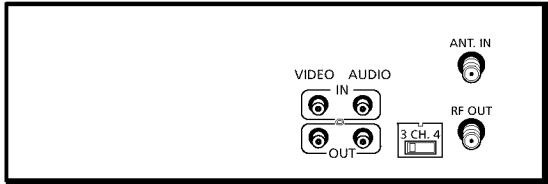

3 CH. 4 Switch Selects the channel to which you will tune the TV to see the VCR picture if you connect the VCR using one of the basic hookups.

AUDIO and VIDEO IN Jacks Receives signals from another component, like a VCR or camcorder, when it is connected to these jacks. Use INPUT on the remote to select "L" to record from these jacks. For more information about the VIDEO INPUT, see page 53.

AUDIO and VIDEO OUT Jacks Sends signals from VCR to another component, like a TV or VCR, when it is connected to these jacks.

ANT IN Jack Receives a signal from an antenna or cable system when attached.

RF OUT Jack Passes signal to TV using the cable supplied.

REFERENCE

HOW TO FIND YOUR TV'S VIDEO INPUT CHANNEL

You need to tune your TV to the Video Input Channel if you are using the VCR's VIDEO/STEREO OUT jacks to connect to the TV's VIDEO/STEREO INPUT jacks. You must select this "channel" before you can see the VCR's menus, the cable or antenna reception, and the content that's on a tape.

The video channel on TVs varies for different brands and different models. Below are some steps to try:

- If your TV brand is RCA, GE, or PROSCAN, press the TV button on the remote control that came with the VCR. Then press the INPUT button on the remote.
- If you have another brand of TV, consult the section, VCR BASICS, to see if the VCR's remote control can be set to control your TV. If so, follow the step above.

If those options do not work, try the following ideas. You might access the Video Input Channel by:

- pressing a button on the remote (see table below)
- selecting the channel from the TV's menu system (see table below)
- tuning directly to the channel by selecting a specific channel number (see table below)
- going through all the channels in the channel list by pressing the channel up or down buttons on the TV.

Some common scenarios are listed in the Video Input Channel Variations table that follows:

Video Input Channel Variations		
Button/Switch on the TV	Button on the TV Remote	Channel Number
VIDEO	VID 1	00
SIGNAL	LINE	90
VID 1	VID	91
VID 2	VIDEO	92
S-VID	S-VID	93
S-VIDEO	INPUT	VID 1
	S-VIDEO	VID 2
	SOURCE	
	AUX	

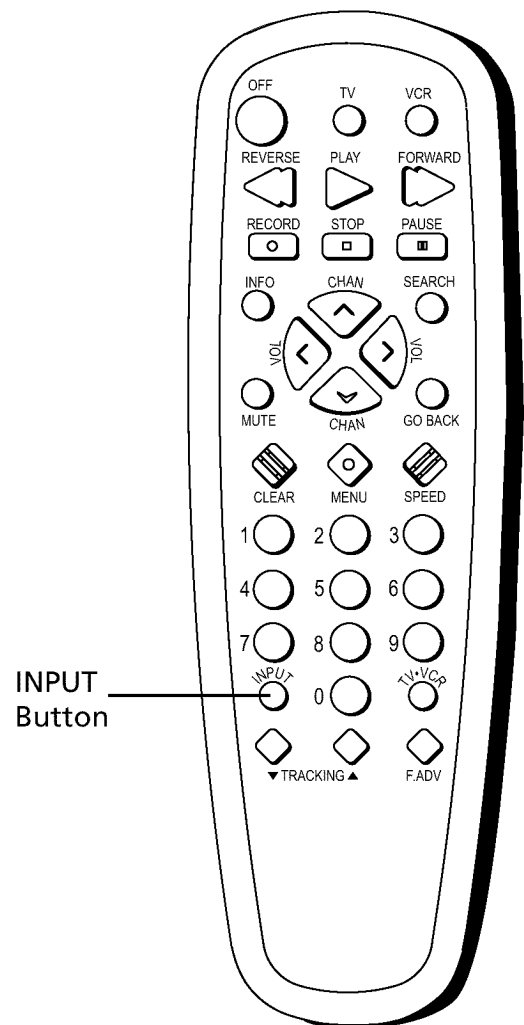

TROUBLESHOOTING TIPS

No power

- Check to make sure it is plugged into an operating outlet.
- Check to make sure your connections are correct.

VCR does not respond to remote

- Press VCR to set remote to control the VCR.
- Check to make sure there are no objects between the VCR and remote.
- The batteries may need changing.
- Make sure the Remote VCR1/VCR2 setting is set to VCR1 so the remote that came packed with your VCR can operate it.

Poor or no picture for normal TV viewing

- Check to make sure the VCR indicator is off.
- Check to make sure the TV is switched to an active channel.
- Check to make sure the antenna connections are secure and correct.

Snowy or no picture during playback

- Press TV•VCR to turn VCR indicator on.
- Check TV channel selected (3 or 4) to make sure it matches the channel selected with 3 CH. 4 switch on back of VCR.
- Check to make sure the TV's fine tuning is correct for the channel you have selected.
- Check video cable connections between VCR and TV monitor.
- Check to make sure the TV monitor is set to video input.
- Try another tape.
- Some snow/streaks are normal during search, stop action, frame advance, and slow-motion playback.

Streaks in picture during normal playback

- Press one of the TRACKING buttons to move streaks up or down for the best picture.
- Check to make sure the tape is of good quality and not worn out.

Time counter not working or time counter not working in search modes

- The time counter does not advance during unrecorded portions of tape. When an unrecorded segment of tape is encountered, the time counter will hold its count until recorded material is detected again.

REFERENCE

- A minus (–) will appear in front of the time if you rewind the tape farther back than a counter reading of 0:00:00.
- The time counter disappears during search; this is normal.

Will not record or play

- Check to make sure there is a tape in the VCR.
- Try ejecting and reinserting the cassette.
- Check to make sure the tape is not broken.
- Check to make sure the VCR is not in pause mode. Press PAUSE or PLAY to return to normal playback.
- Check the ProTect Plus™ feature.

Rewind does not operate

- Check to make sure the tape is not already rewound.

VCR Plus+ or timer recording not made or wrong program recorded

- Check to make sure the correct VCR Plus+ code is entered.
- Check to make sure the cable box or satellite receiver was turned on when recording was to begin.
- Check to make sure the program was entered correctly (wrong channel or times).
- Power interruption. Reset the clock.
- Check to see if time and date are correct – including AM/PM.
- Check to make sure the program did not exceed the tape's length or the tape was not rewound beforehand.
- Check to make sure the VCR was turned off at the time recording was to start.
- Check to make sure there was a tape in the VCR and the cassette's safety tab was intact.
- VCR ejects cassette when the end of the tape is reached during a timer recording.
- Check to make sure VCR Plus+ setup was completed correctly.

Will not record

- Check to make sure the safety tab is intact.
- Check to make sure the VCR is not in the line mode. Press INPUT on the remote.

Internal clock shows incorrect time or date

- Power interruption.
- Check to make sure the clock is set accurately (check AM/PM and date).
- Check Daylight-Saving setting. The clock may have adjusted for daylight-saving time.

REFERENCE

Time did not adjust for daylight-saving time

- Check to make sure daylight-saving feature is set correctly.

VCR makes noise when stopped

- VCR is removing tape from heads. This is normal. The head cylinder inside the VCR will continue to rotate for a few minutes after you put the VCR in the stop mode.

Will not AUTO CHANNEL SEARCH active channels correctly

- Check to make sure the antenna connections are secure and correct.
- Check to make sure the Signal Type: CABLE/ANTENNA feature is set correctly.
- If Detect Automatically was selected for the Signal Type in the AUTO CHANNEL SEARCH menu, try using either CABLE TV or ANTENNA instead.
- May not be necessary if using a cable box for all channels. Contact your local cable company for more information.

Tape plays back in slow motion

- Press PLAY to return to normal playback.

Cannot select channels over 69

- Cable channels over 69 can only be selected if Signal Type: CABLE/ANTENNA feature is set to CABLE.

Cassette with safety tab removed does not start to play automatically

- Check to make sure the Auto Play ON/OFF feature is set to ON.

TIMER indicator flashes

- Clock is not set.
- Check to make sure there is a cassette in the VCR when a timer recording is set.
- TIMER and RECORD indicators flash when the ProTect Plus™ Locking feature is activated.

Time counter disappears during searching

- This is normal.

On-screen menus appear in English, French, or Spanish

- Check LANGUAGE feature.

REFERENCE

SPECIFICATIONS

Format:	VHS
Record/Playback System:	Video: 2-head Audio: Mono record/playback system
Video Signal System:	EIA standard: NTSC color
Antenna:	75-ohm external VHF/UHF combined antenna terminal
Tuner:	USA: 181 channels capability* (125 cable channels) Canada: 178 channels capability* (122 cable channels)
Type:	AutoProgramming frequency synthesis
Power Requirement:	120V AC, 60 Hz
Power Consumption:	17 watts (standby < 3 watts)
Dimensions:	3.54 inches high (90 mm) 14.1 inches wide (360 mm) 10.9 inches deep (273 mm)
Weight:	7.8 pounds (3.55 kg)
Storage Temperature Range:	- 22°F to +149°F (-30°C to +65°C)
Operating Temperature Range:	+41°F to +104°F (+5°C to +40°C)

*Check your cable company's compatibility requirements.

CLEANING THE VCR

Use a soft cloth or dusting attachment of your vacuum cleaner to dust your VCR. Remove dust from the ventilation holes on the top, back, sides, and bottom of the cabinet.

Plastic surfaces are easily scratched and can be marred by alcohol and various solvents. Avoid excessive use of oil-based furniture polishes since the materials used in the cabinet will accumulate more dust. We recommend using a nonabrasive, antistatic cleaner and polisher.

Specifications are subject to change.

REFERENCE

LIMITED WARRANTY

What your warranty covers:

- Any defect in materials or workmanship.

For how long after your purchase:

- Ninety days for labor charges.
- One year for parts.

The warranty period for rental units begins with the first rental or 45 days from date of shipment to the rental firm, whichever comes first.

What we will do:

- Pay any Authorized RCA VCR Service Center the labor charges to repair your VCR.
- Pay any Authorized RCA VCR Service Center for the new or, at our option, refurbished replacement parts required to repair your VCR.

How you get service:

- Take your VCR to any Authorized RCA VCR Service Center. To identify your nearest Authorized RCA VCR Service Center, ask your dealer, look in the Yellow Pages, or call 1-800-336-1900.
- Show the Authorized Service Center Representative your evidence or purchase date or first rental.
- Pick up your VCR when repairs are completed.

What your warranty does not cover:

- Customer instruction. (Your Owner's Manual clearly describes how to install, adjust, and operate your VCR. Any additional information should be obtained from your Dealer.)
- Installation and related adjustments.
- Signal reception problems not caused by your VCR.
- Damage from misuse or neglect.
- Cleaning of video/audio heads.
- Batteries.
- A VCR that has been modified or incorporated into other products or is used for institutional or other commercial purposes.
- A VCR purchased or serviced outside the USA.
- Acts of God, such as but not limited to lightning damage.

Product Registration:

- Please complete and mail the Product Registration Card packed with your VCR. It will make it easier to contact you should it ever be necessary. The return of the card is not required for warranty coverage.

How state law relates to this warranty:

- This warranty gives you specific legal rights and you also may have other rights that vary from state to state.

If you purchased your VCR outside the United States:

- This warranty does not apply. Contact your dealer for warranty information.

INDEX

A

Adding/removing channels 12
ANT IN jack 5, 52
Audio/video jacks 5, 20, 52
Auto channel search 10
Auto play feature 17, 22
Automatic rewind 23
Automatic tracking 23

B

Back Panel diagram 52
Batteries
 installing in the remote 4

C

Cable box setup 9
Cables 44
CHAN buttons 20, 21, 34
Channel 3/4 switch 5
Channel List 28
CHANNEL/TRACKING buttons 50
Channels
 detecting automatically 10, 11
Channels, adding/removing 12
Channels list, VCR 9
Cleaning the VCR 57
CLEAR button 20, 21
Clearing programs 30
Coaxial Cables
 positioning 43
Commercial Scan 38
Component buttons 20
Connecting Your VCR 44
Connecting your VCR 4
Connections 43

audio/video cable 45
TV, a/v jacks, box to unscramble pay channel 48
TV with a/v jacks 47
TV with RF jack only 46
Two VCRs 31
Copying and editing tapes 31

D

Date and Time, setting 12
Daylight-saving time 12

E

Ejecting a tape 23
EnergySaver feature 17
Express Recording (XPR) 26

F

F ADV button 20, 22
Forward and reverse search 38
Frame advance 38
Front panel brightness 18
Front panel diagram 50
FWD button 20, 50

G

GO BACK button 20, 21
Go-To search 40

I

Index search 40
INFO button 20
Initial Setup 5
INPUT button 20

INDEX

J

- Jacks
 - ANT IN 52
 - Audio/Video 52
 - audio/Video 20
 - RF OUT 52
- Jacks, types of 44

L

- Language feature 8
- Locking feature 40

M

- MENU button 6, 9, 21
- MUTE button 22, 34

N

- Number buttons 6, 13, 21

O

- ON•OFF button 34
- On-screen Displays 42
- Overheating 43

P

- PAUSE button 21, 22, 23
- Picture search options 38
- PLAY button 21, 22
- PLAY•PAUSE button 50
- Playing a tape 22
- Plugging in the VCR 4
- POWER button 20, 23, 50
- Power surges 43
- Pro-Tect Plus™ Locking feature 40
- Problem solving 54
- Programming the remote 33
 - to operate TVs 34
- PROGRAMS OVERLAP message 29

R

- RECORD button 21, 23, 50
- Recording
 - copying and editing tapes 31
 - Express (XPR) 26
 - speeds 18
 - timer 27
 - VCR Plus+ 28
 - XPR (Express) 26
- Remote Control
 - buttons 20
 - installing batteries 4
 - TV/VCR function buttons 21
- Removing/adding channels 12
- REV button 21, 50
- Reviewing programs 30
- Rewind, automatic 23
- RF OUT jack 5, 52

INDEX

S

Safety tab 23

Search

- Commercial Scan 38
- forward and reverse 38
- frame advance 38
- go-to 40
- index 40

SEARCH button 21

Set up

- cable box 9
- initial 5
- language 8
- using menus 8

Signal type, changing 11

SLOW buttons 22

SLP 23

SP 23

Specifications 57

SPEED button 21, 23

Speeds, recording/playback

- SLP 18
- SP 18

STOP button 21, 23

STOP•EJECT button 50

T

Tape

- ejecting 23
- playing 22

Tape Speeds

- LP 18
- SLP 18

Time and Date

- Daylight Saving 12
- setting manually 13

Time Counter 41

TIMER indicator 29

Timer recording 26, 27

- stopping 30
- with VCR Plus+ 26

Tips, troubleshooting 54

Tracking 41

TRACKING buttons 21

Troubleshooting tips 54

TV button 20, 34

TV codes 35

TV function buttons 21

TV, programming the remote to control 34

TV•VCR button 21

V

VCR button 20

VCR channel list 9

VCR, cleaning 57

VCR connections 44

VCR MAIN MENU 9

VCR Plus+ channel list 14

VCR viewing channel 5

VOL buttons 22, 34

W

Warranty 58

X

XPR (express recording) 26

If your VCR needs service, please contact your dealer or the nearest Servicenter from the yellow pages. Please do not send any products to the Indianapolis address listed in this manual or on the carton. This will only add delays in service for your product.

 **THOMSON CONSUMER ELECTRONICS**
10330 North Meridian Street
Indianapolis, IN 46290

©1998 Thomson Consumer Electronics, Inc.
Trademark(s)® Registered
Marca(s) Registrada(s)
Printed in Korea
TOCOM 15407760

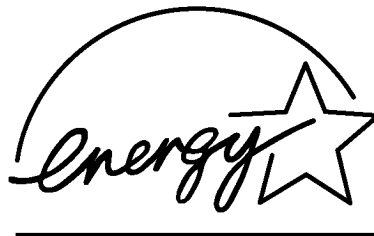

As an ENERGY STAR® Partner, Thomson Consumer Electronics has determined that this product or product model meets the ENERGY STAR® guidelines for energy efficiency.