

RCA

USER'S GUIDE

camcordercamcordercamcor
dercamcordercamcordercam
cordercamcordercamcorder
camcordercamcordercamcor
dercamcordercamcordercam
cordercamcordercamcorder
camcordercamcordercamcor
dercamcordercamcordercam
cordercamcordercamcorder
camcordercamcordercamcor
dercamcordercamcordercam
cordercamcordercamcorder
camcordercamcordercamcor
dercamcordercamcordercam
cordercamcordercamcorder
camcordercamcordercamcor
dercamcordercamcordercam
cordercamcordercamcorder
camcordercamcordercamcor
dercamcordercamcordercam
cordercamcordercamcorder
camcordercamcordercamcor
dercamcordercamcordercam
corderca mcorder
camcor derca
mcord erc
am cor
de rca
m cord
er cam
co rd
e r





CC4252

Important Safety Information

Be sure to read all the safety information before you begin to use this product.

WARNING: To reduce the risk of fire or shock hazard, do not expose camcorder or AC adapter/charger to rain or moisture.

CAUTION RISK OF ELECTRIC SHOCK DO NOT OPEN		This symbol indicates “dangerous voltage” inside the product that presents a risk of electric shock or personal injury.
ATTENTION RISQUE DE CHOC ELECTRIQUE NE PAS OUVRIR		This symbol indicates important instructions accompanying the product.

TO REDUCE THE RISK OF ELECTRIC SHOCK, DO NOT REMOVE THE COVER (OR BACK). NO USER-SERVICEABLE PARTS ARE INSIDE. REFER SERVICING TO QUALIFIED SERVICE PERSONNEL.

Cautions

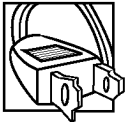

CAUTION: To prevent electric shock, match wide blade of plug to wide slot, fully insert.

ATTENTION: Pour éviter les chocs électriques, introduire la lame la plus large de la fiche dans la borne correspondante de la prise et pousser jusqu'au fond.

To reduce risk of injury, charge only rechargeable batteries recommended by the manufacturer for this camcorder. Other types of batteries may burst causing damage and personal injury.

FCC Regulations state that unauthorized changes or modifications to this equipment may void the user's authority to operate it.

Product Registration

Please fill out the product registration card and return it immediately. Returning this card allows us to contact you if needed.

Keep your sales receipt for proof of purchase to obtain warranty parts and service and attach it here. Record the serial number and model numbers located on the bottom of the camcorder.

Model No: CC4252
Serial No: _____
Purchase Date: _____
Purchased From: _____

Assistance

We want to make sure you enjoy your new camcorder. If you have any questions, call:

Camcorder Exchange Warranty.....800-283-6503 (pages 55-56)

Customer Service.....800-336-1900 (page 54)

Accessories..... 800-338-0376 (pages 41-47)

Table of Contents

First Time Operation	3	Battery Level Indicator	13
Assistance	3	Battery Care	14
Attaching the Adaptor/Charger ..	4	Battery Storage	14
Using the Handstrap and		Battery Safety Precautions ..	14
Lens Cap	4	Optional Car Cord Adaptor	15
Turning on the Camcorder	5	Videocassettes	16
Inserting a Tape	5	Erase Protection.....	16
Adjusting the Viewfinder.....	6	Recording and Playback	
Starting and Stopping Recording	6	Speeds	16
Playing Back Recordings	7	Inserting and Removing	17
Turning the Camcorder OFF	7	Care and Storage	17
Replacing the Lens Cap.....	7	Date and Time Display	18
Operating Controls	8	Setting.....	18
Reviewing Camcorder Controls .	9	Correcting.....	18
Adaptor Charger	10	Recording Time and Date.....	19
Using	10	Viewfinder Displays	19
Removing	10	Selecting	19
Powering Your Camcorder	10	Charging the Clock Battery	19
Battery Power	11	Recording	20
Charging the Battery	11	Using the Viewfinder	20
Batteries.....	12	Eyepiece Focus Control	20
Charging	12		
Removing	12		

Table of Contents

Tilt Adjustment	21	Stop-Action Pause	34
Bright Control	21	Tracking	35
Viewfinder Displays	22	Playback on a TV Using A/V Inputs	36
Display Button	24	Installation	36
Quick Review Feature	24	How to Copy Tapes on the VCR	37
Camera Edit Feature	25	Viewing What the Camcorder is Seeing	37
Auto Shot Feature	25	Playing Back on a TV Without A/V Inputs	38
Microphone	25	Playback Operation	39
Auto Focus	25	Viewing What the Camcorder is Recording	39
Macro Focus	25	Normal TV Viewing	39
Tape Remaining Display	26	Accessories	40
Electronic Indexing	26	Attaching the Shoulder Strap ...	40
Zooming	27	Optional Accessories	41
Using the Zoom Buttons	27	Lens Hood Removing	44
Tape Counter	28	Accessory Order Form	45
Memory Stop Feature	28	Trouble Shooting	48
Recording Tips	29	Camcorder Care and Maintenance	51
Travel Tips	29	Specifications	53
Titler	30	Waranty	55
Creating	31	Index	57
Correcting Errors	31		
Chart of Characters	31		
Recording in the Camcorder	32		
Recording While Copying	32		
Playback	33		
Viewfinder Playback	33		
Playing Back a Tape	33		
Features	34		
Tape Positioning	34		
Visual Searching	34		

First-Time Operation

This section describes the steps necessary to set up your camcorder to record. Refer to the other sections for detailed operation and feature options.

Assistance

The toll-free numbers are available to help you with any problem you may encounter.

Camcorder Exchange Warranty.....	800-283-6503
Customer Service.....	800-336-1900
Accessories.....	800-338-0376

1. Unpack the camcorder and accessories.

- Save the packing materials and box in case you ever need to ship or store your camcorder.
- The items shown below are packed with your camcorder. If any are missing or appear damaged, contact your dealer immediately.

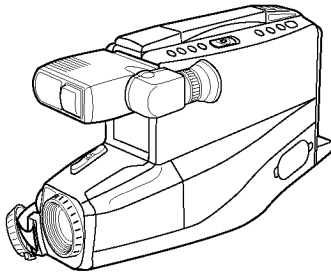

Model CC4252

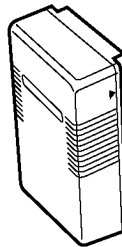

WARNING:
LEAD-ACID
BATTERY.
MUST BE
DISPOSED OF
PROPERLY.

Rechargeable 10-Volt Battery
Stock No. EP096FS

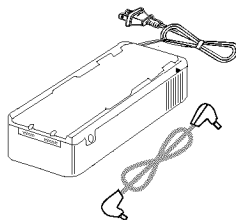

AC Adapter/Charger: Stock No. 241044
DC Cable: Stock No. 23328

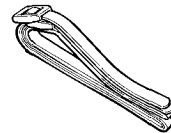

Shoulder Strap
Stock No. 241305 or
Stock No. 227327

Caution: Do not use this adapter/charger for any purpose other than charging the EP096FS or EP096FL battery pack or supplying power to the camcorder.

(Continued on next page)

First-Time Operation

2. Attach the adapter/charger.

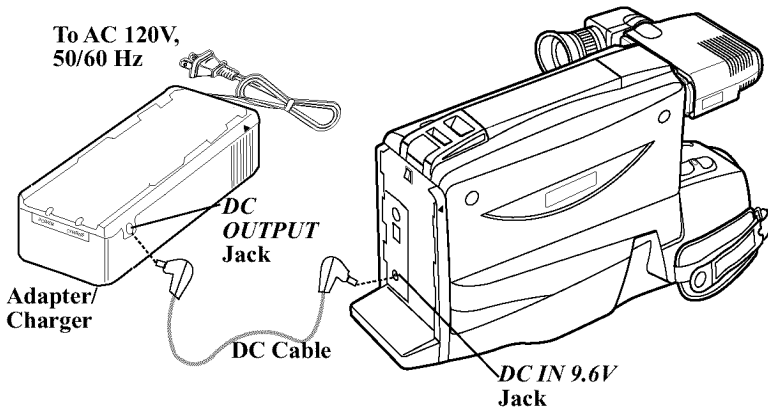

Since the battery must be charged before it can be used the first time, attach the adapter/charger to the camcorder.

1. Attach one end of the adapter/charger's DC cable to the *DC OUTPUT* jack on the side of the adapter/charger.
2. Attach the other end of the cable to the *DC IN 9.6V* jack on the camcorder.
3. Plug the adapter/charger's plug into an operating outlet.
4. *Details are on page 10.*

3. Adjust the handstrap, remove lens cap, and attach it to the handstrap.

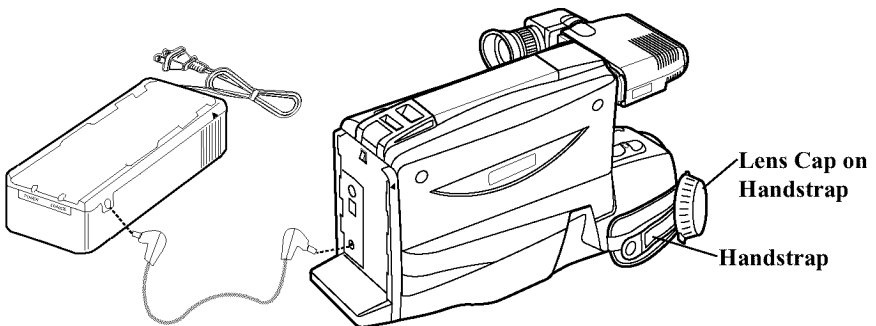

1. Open the handstrap, insert your hand, and adjust the handstrap to fit your hand.
2. Remove the lens cap and attach it to the handstrap *where shown*.

First-Time Operation

4. Insert a tape.

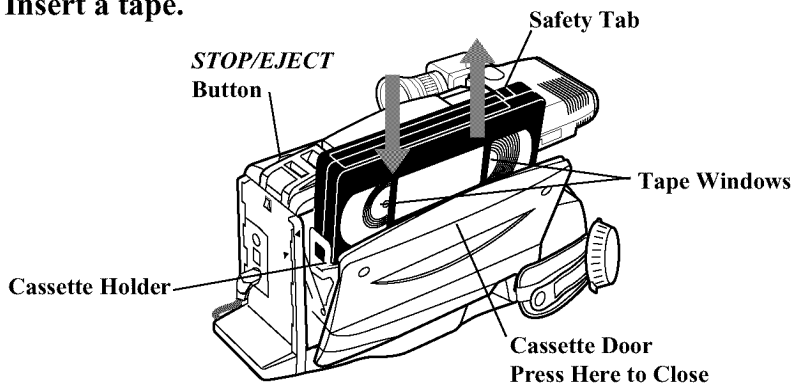

- Press *STOP/EJECT* to open the cassette compartment.
- Insert the cassette with the safety tab facing up and the tape windows facing out.
- Press the cassette down gently until it locks into place, and close the cassette compartment door.
- *Details are on page 17.*

5. Turn on the camcorder.

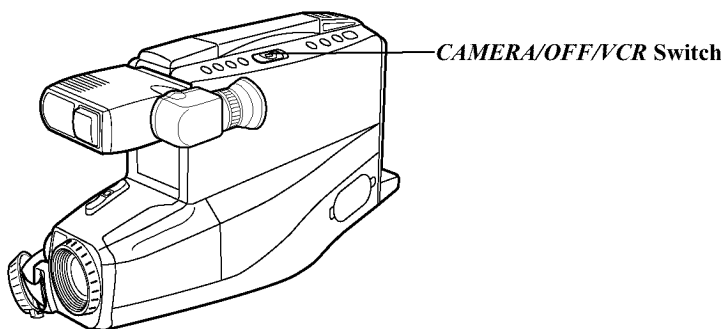

- Press and hold the small button on the *CAMERA/OFF/VCR* switch while sliding it to *CAMERA*. The camcorder enters record-pause.
- The position of this switch tells the camcorder whether you want to record (*CAMERA*), turn the power off (*OFF*), or play back tapes (*VCR*).
- The camcorder will automatically turn off if it remains in record-pause for five minutes. Place the switch to *OFF* and then back to *CAMERA* to turn the camcorder back on.

(Continued on next page)

First-Time Operation

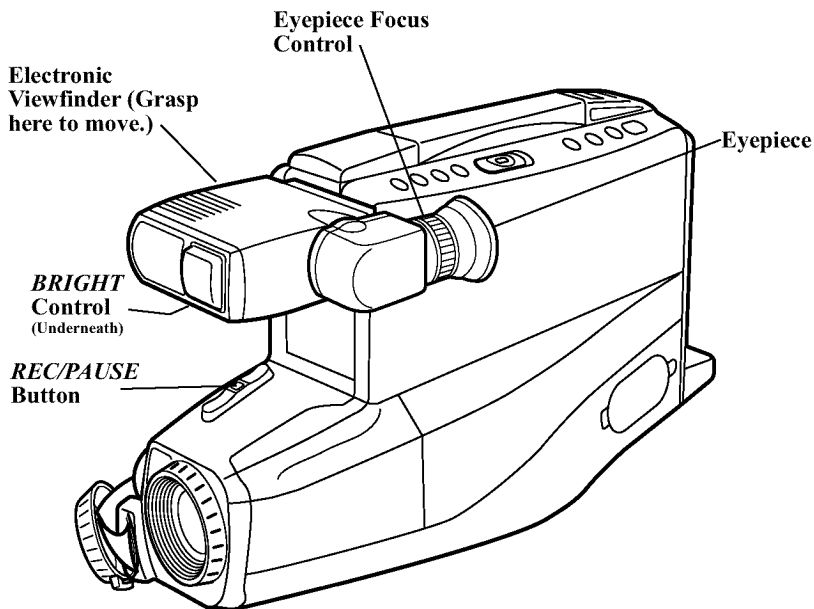

6. Adjust the viewfinder and eyepiece focus control.

- Grasp the viewfinder and rotate it horizontally.
- Pull the viewfinder out from the camcorder and rotate the eyepiece into a comfortable viewing position.

Caution: Pulling on the eyepiece might damage the eyepiece or camcorder.

- Turn the eyepiece focus control to adjust the focus of the viewfinder for your vision.
- Adjust the brightness of the image in the viewfinder by turning the *BRIGHT* control.

7. Start and stop recording.

- Press and release the *REC/PAUSE* button to start recording. *REC* appears in the viewfinder when the camcorder is recording.
- Press and release the *REC/PAUSE* button again to stop recording. The camcorder is now in the record-pause mode (**||** appears in the viewfinder when the camcorder is in record-pause).

First-Time Operation

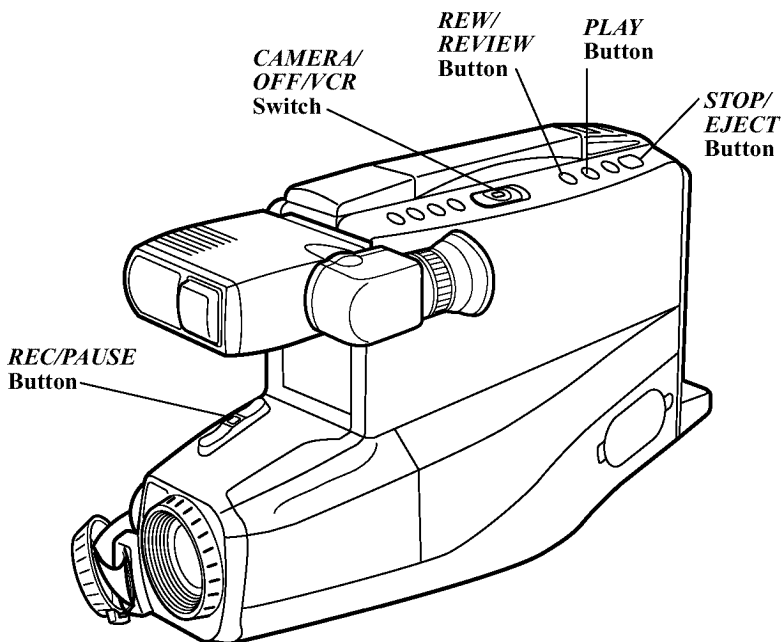

8. Play back what you have recorded.

- Press the *REC/PAUSE* button to pause recording.
- Press and hold the small button while you set the *CAMERA/OFF/VCR* switch to *VCR*.
- Press *REW/REVIEW* to rewind the tape.
- Press *PLAY* to play back the tape.
- Press *STOP/EJECT* when you are finished playing back the tape.
- *Details on viewfinder playback are on page 33.*

9. Set the *CAMERA/OFF/VCR* switch to *OFF* to turn off the camcorder.

10. Replace the lens cap.

(Continued on next page)

First-Time Operation

11. Review camcorder's operating controls.

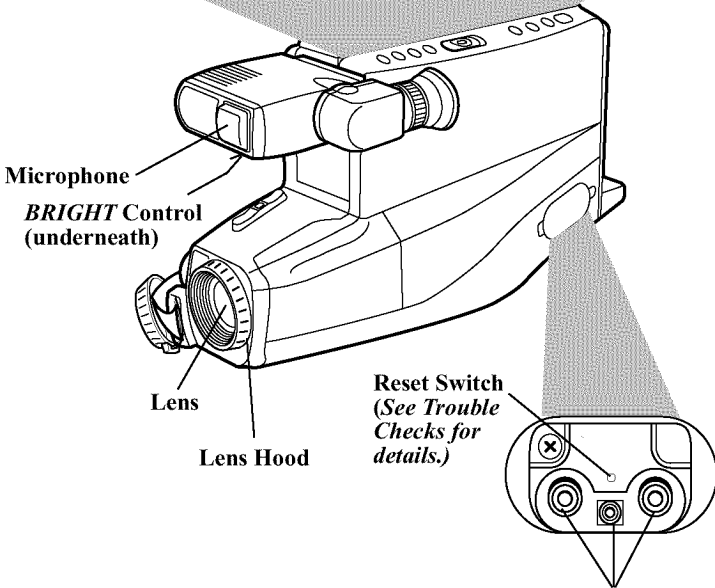
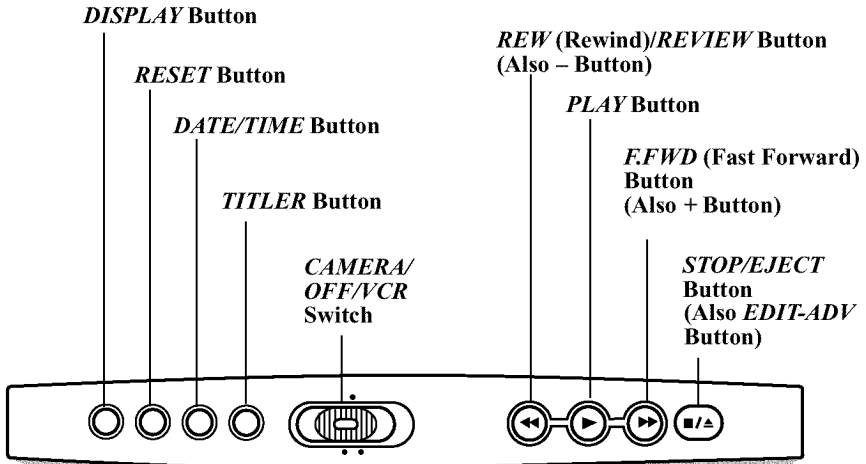

VIDEO, AUDIO and RF DC OUT Jacks (Located Behind Small Cover)

First-Time Operation

11. Review camcorder's operating controls. (*continued*)

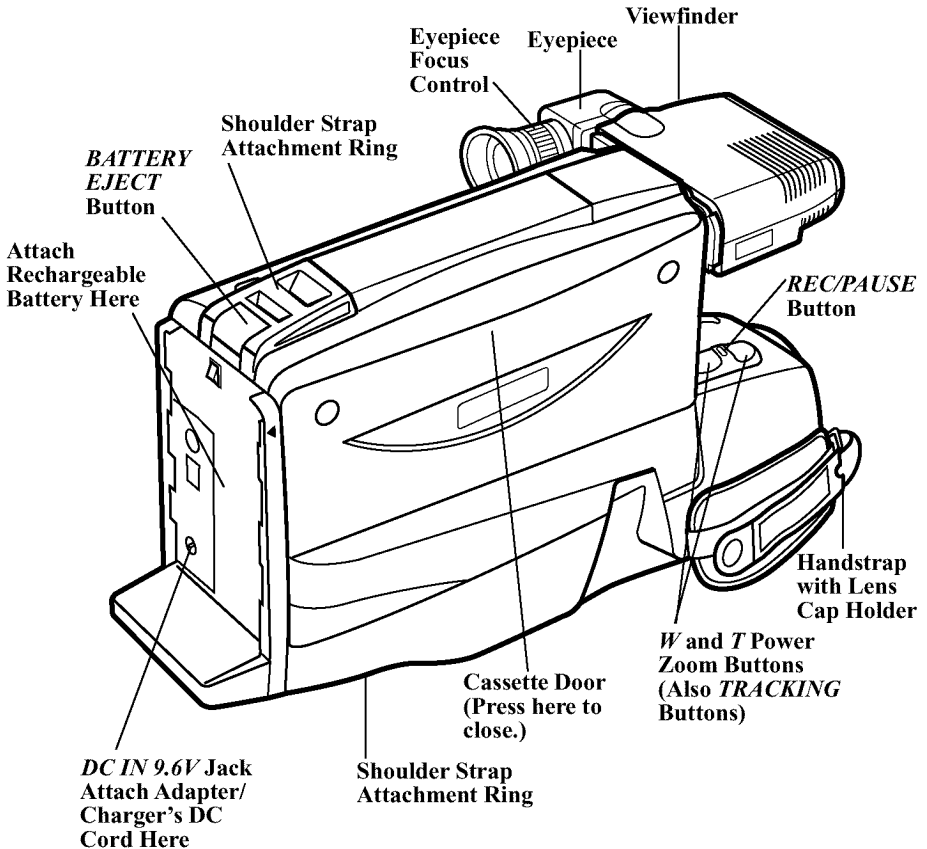

Power Your Camcorder

Use the Adapter/Charger to Power Your Camcorder

The adapter/charger attaches to the camcorder and lets you power your camcorder directly from standard household power. The adapter/charger operates on 120 volts, 50/60 Hz, and can be used to power the camcorder or recharge the battery.

Caution: Do not attempt to use a “power converter” to use your AC adapter/charger on a power source other than 120 volts, 50/60 Hz, or the adapter/charger and camcorder may be damaged. If you wish to operate the AC adapter/charger on a power source other than 120 volts, 50/60 Hz, use only a transformer-type power converter. **Do not use “solid-state” or “switching-type” power converters. They will damage your AC adapter/charger.** An optional CPS014, shown on page 42, is designed for use on 100-240 volts, 50/60 Hz.

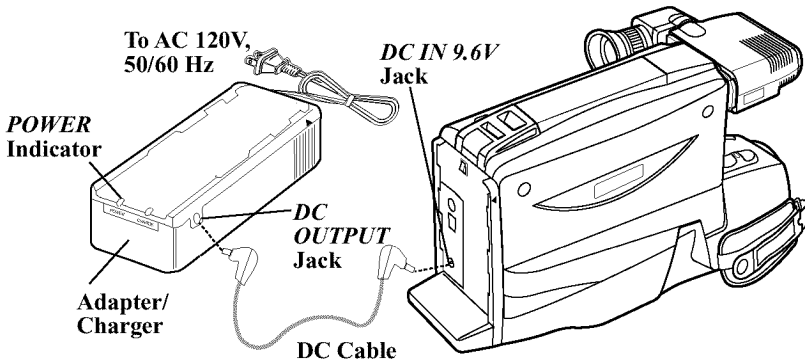

Caution: Do not use this adapter/charger for any other purpose other than charging the EP096FS or EP096FL battery pack or supplying power to the camcorder.

Attaching the Adapter/Charger

1. Attach one end of the adapter/charger's DC cable to the *DC OUTPUT* jack on the adapter/charger.
2. Attach the other end of the cable to the *DC IN 9.6V* jack on the camcorder.
3. Plug the adapter/charger's plug into an operating outlet. The *POWER* indicator on the adapter/charger lights when it is properly connected.

Notes: The adapter/charger cannot charge the battery and operate the camcorder at the same time. If you connect both, the adapter/charger will power the camcorder. Remove the

adapter/charger's cable from the *DC OUTPUT* jack to charge the battery.

When using the adapter/charger to power the camcorder, the battery level indicator may display . This indicator is used for battery operation and has no meaning when using the adapter/charger to power the camcorder.

Removing the Adapter/Charger

1. Unplug the adapter/charger from the wall outlet.
2. Remove the DC cable from the adapter/charger and camcorder.

Power Your Camcorder

Use the Battery and Charger to Power the Camera

Charging the Battery

The battery must be charged before it can be used the first time. Initial charging will take approximately two hours. The camcorder's operating time depends on how often you turn the power on and off and how much you use zoom and pause. Conserve battery power by turning the camcorder off during recording breaks.

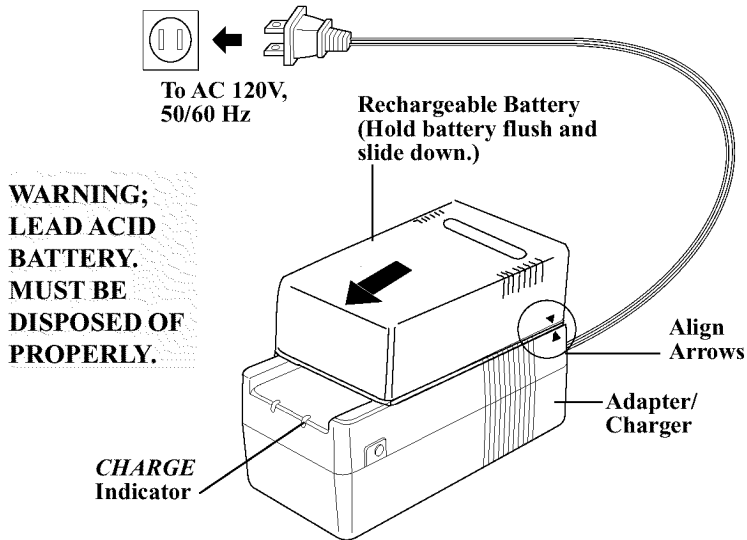

Caution: When a battery is attached to the adapter/charger, do not turn them upside down. The battery may fall off and be damaged or cause injury.

Charging the Battery

If the DC cable is attached to the *DC OUTPUT* jack on the adapter/charger, remove it.

1. Align reference mark on battery with mark on adapter/charger.
2. Hold the battery flush against the adapter/charger and slide it in the direction of the arrow.
3. Plug adapter/charger into nearest AC outlet (120V, 50/60Hz).

4. If the battery is properly connected, the adapter/charger's *CHARGE* indicator lights.

Note: Your battery will provide better service if you charge it before and after use and store it at room temperature.

5. Remove the charged battery by sliding it up and off the adapter/charger.
6. Attach the charged battery to the camcorder *as shown on the next page*.

Power Your Camcorder

Using the Battery to Power Your Camcorder *(continued)*

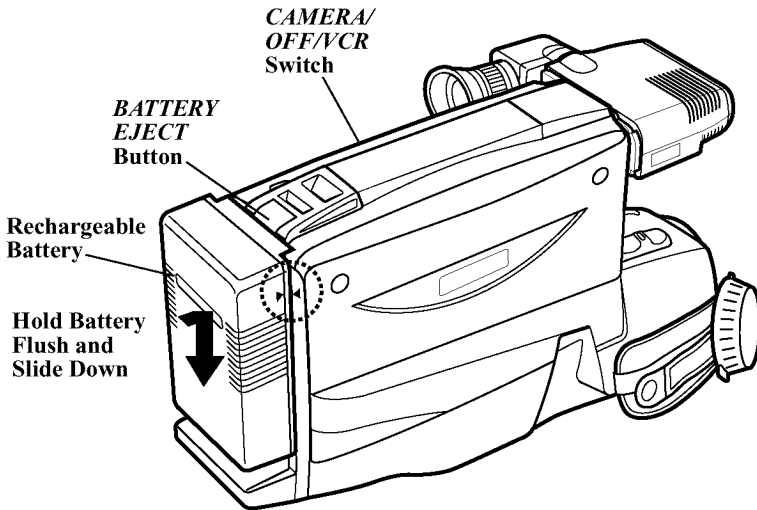

Charging the Battery

If the DC cable is attached to the camcorder, remove it before attaching the battery.

1. Align the reference arrow on the battery to the arrow on the back of the camcorder.
2. Hold the battery flush against the camcorder while sliding it down in the direction of the arrow.

3. Press and hold the small button on the *CAMERA/OFF/VCR* switch while you slide it to *CAMERA*.

Removing the Battery

1. Set the *CAMERA/OFF/VCR* switch to *OFF*.
2. Press and hold the *BATTERY EJECT* button and remove the battery.

ATTENTION: THE RECHARGEABLE BATTERY CONTAINED IN THIS PRODUCT IS RECYCLABLE. AT THE END OF ITS USEFUL LIFE, UNDER VARIOUS STATE LAWS, IT MAY BE ILLEGAL TO DISPOSE OF THIS BATTERY IN THE MUNICIPAL WASTE STREAM. CHECK WITH YOUR LOCAL SOLID WASTE OFFICIALS FOR DETAILS IN YOUR AREA FOR RECYCLING OPTIONS OR PROPER DISPOSAL.



Pb

Power Your Camcorder

Use the Battery to Power Your Camcorder *(continued)*



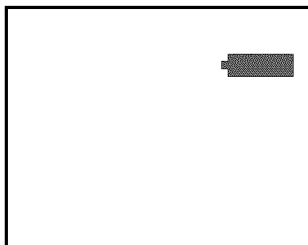

Battery Level Indicator

The battery level indicator appears in the viewfinder and shows you the amount of power in the rechargeable battery.



**Battery Level Indicator Display
in Viewfinder**

Note: If the battery level display does not appear, press *DISPLAY*.

- When  appears, the battery is fully charged.
- As the power is used  and  appear.
- When the battery power is almost gone,  flashes in the viewfinder. Recharge the battery or use the adapter/charger before continuing to use the camcorder. Set the *CAMERA/OFF/VCR* switch to *OFF* to turn off the camcorder before replacing the battery.

Notes: When recording using the rechargeable battery, the battery level indicator flashes to warn you of low battery power even if you do not have the battery level indicator displayed.

The battery level indicator will not be recorded on the tape when it appears in the viewfinder.

The battery level indicator has no meaning when you use the adapter/charger or optional car cord to power the camcorder.

Cautions: When a battery reaches empty during use, the camcorder turns off. The battery should still have enough reserve power to eject the cassette when you press *STOP/EJECT*.

If the camcorder does not eject the cassette when you press *STOP/EJECT*, **do not force the cassette door open**. This will damage your camcorder.

Before attempting to eject the cassette, power the camcorder with the adapter/charger or recharge the battery.

Power Your Camcorder

Use the Battery to Power Your Camcorder *(continued)*

Battery Care

- Your battery will provide better service and longer performance if you charge it before and after use, and store it at normal room temperature.
- The battery should be charged at a temperature of 32°F-95°F (0°C-35°C) to prevent damage.
- Do not operate the battery at temperatures below 14°F (-10°C) or above 95°F (35°C). The battery might be damaged if operated at temperatures above 122°F (50°C). Operation time will decrease at extremely low temperatures.
- After repeated chargings and use the operation time will decrease. When the operation time becomes too short to be useful, it is time to replace the battery.

Battery Storage

- Store the battery at normal room temperature.
- Lead acid batteries discharge if not used. Recharge the battery at least once ever six months or you may not be able to recharge it.
- A battery stored for a long period might not supply power for the specified time. Additional rechargings might help restore the battery's operation time.

Battery Safety Precautions

- Batteries being recharged that have not been used for an extended period may continue to charge after the normal time. Do not charge a battery for more than 24 hours.
- If the *CHARGE* indicator on the adapter/charger starts flashing, remove the battery, and reattach it. If after several attempts, the indicator continues to flash, your battery cannot take a charge and must be replaced.
- Throwing the battery into a fire or exposing the battery to excessive heat – over 149°F (65°C) could be hazardous.
- Do not short the battery's terminals.
- Allow the battery to cool down before attaching it to the adapter/charger. The *CHARGE* indicator will not light and the battery will not charge if you attach a hot battery.
- Do not attempt to disassemble or modify the battery. There are no user-serviceable parts inside.
- Use the battery only with specified AC adapter/chargers and camcorders.
- If leakage from a damaged battery contacts your skin or clothing, wash it off immediately with running water.

Power Your Camcorder

Using the RCA Optional Car Cord Adapter

The optional DCC096 car cord *shown on page 41* allows you to power your camcorder from the cigarette lighter socket of a car, truck, or RV. It converts 12-volts to a 9.6-volt output.

Note: Consult the installation and operating instructions enclosed with the DCC096 for complete operating instructions.

Caution: The DCC096 car cord is designed to be used only with vehicles having 12-volt negative ground electrical systems.

Warning: To avoid possible damage to the camcorder, use only the DCC096 car cord. It has positive tip polarity and is capable of converting 12 volts to 9.6 volts.

Using the DCC096 Car Cord Adapter

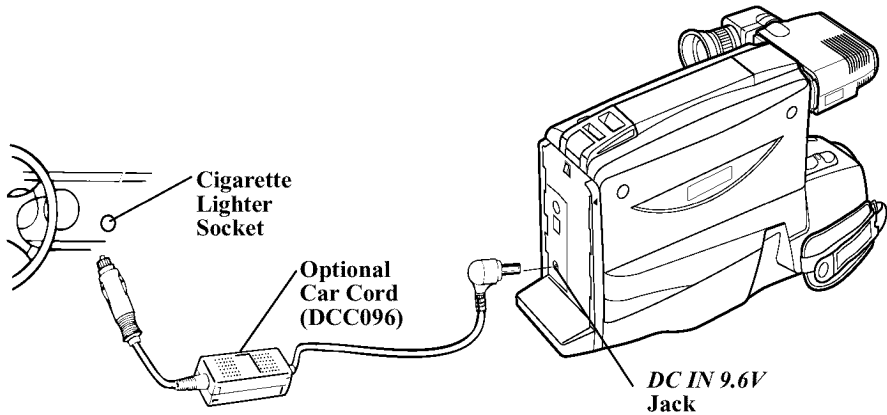

1. Set the *CAMERA/OFF/VCR* switch to *OFF* to turn off the camcorder.
2. If the battery or DC cable is attached to the camcorder, remove it.
3. Insert the small plug on the car cord to the *DC IN 9.6V* jack located on the back of the camcorder.
4. Take the vehicle's cigarette lighter out of the socket.
5. Insert the car cord's cigarette lighter plug into the vehicle's cigarette lighter socket.
6. Press and hold the small button on the *CAMERA/OFF/VCR* switch while you set it to *CAMERA* to turn on the camcorder.

Notes: The vehicle does not have to be turned on for the camcorder to operate from the DC car cord.

When using the car cord to power the camcorder, the battery level indicator has no meaning.

Videocassettes

Make sure you select good quality tapes for your camcorder. Use of poor quality tapes or tapes that have been damaged or mishandled can contaminate the video heads, resulting in a snowy picture or no picture at all during playback. Because there is no control over the type of tape purchased or rented by consumers, **head cleaning is not covered under warranty**. It is considered normal maintenance.

If a snowy picture or no-picture condition persists, consider the use of a dry chemical nonabrasive head-cleaning tape. Be sure to follow the directions with the head-cleaning kit carefully. Improper use of a head cleaner might damage your camcorder.

Erase Protection – Safety Tab

You can use your videocassettes over and over again. To erase a previous recording, record over it.



To prevent accidental erasure, break off the tab.

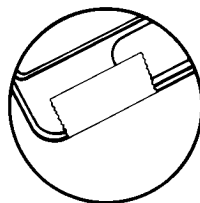

To record on the tape again, cover the hole with vinyl tape.

Recording and Playback Speed and Times

The camcorder records and plays back in VHS standard speed (SP). Listed below are the maximum recording times for popular VHS cassettes.

CASSETTE	RECORDING TIME
T-60	60 Min.
T-120	2 Hrs.
T-160	2 Hrs., 40 Min.
T-180	3 Hrs.

Videocassettes

Inserting and Removing Cassettes

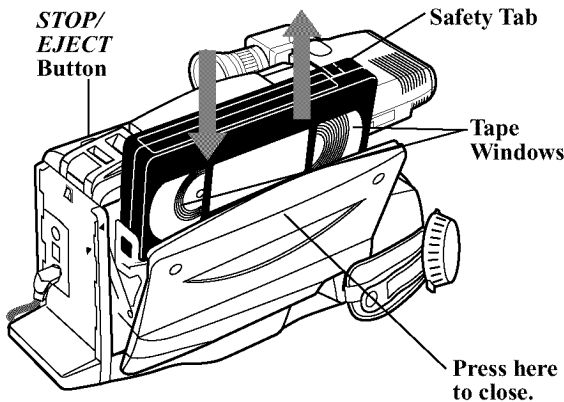

Caution: Insert the cassette only one way with the tape wheel facing up and the tape windows facing out. The cassette should slide easily into the holder. Gently push the cassette down until it locks into place.

1. Attach a power source to the camcorder.
2. Press the *STOP/EJECT* button. The cassette holder opens automatically.
3. Insert the cassette with the tape wheel facing up and tape windows facing
4. Gently close the cassette holder with your hand.

out. Gently push the cassette down until it locks into place.

Cassette Care and Storage

- When you are finished with a cassette, rewind it, remove it from the camcorder, and label it.
- Store cassettes vertically in their protective cases at normal room temperatures. Do not leave your camcorder or cassettes in a car or outdoors for an extended period. Excessive heat or cold might damage your cassettes.
- Keep the cassette away from strong magnetic fields such as electric motors and other devices.
- Keep dust from entering the cassette compartment. All dust is abrasive and causes excessive wear on the tape and the camcorder's recording or playback heads.
- Do not use cassettes with damaged or spliced tape.
- Do not use a cassette if it has been damaged or exposed to moisture. The tape may jam and/or damage your camcorder.
- Break off the safety tab to prevent accidental erasure of your recording.

Date and Time Display

Setting the Time and Date

You must set the correct date and time before it can be displayed and recorded on your tapes. The built-in clock cell must be charged *as described on the next page*.

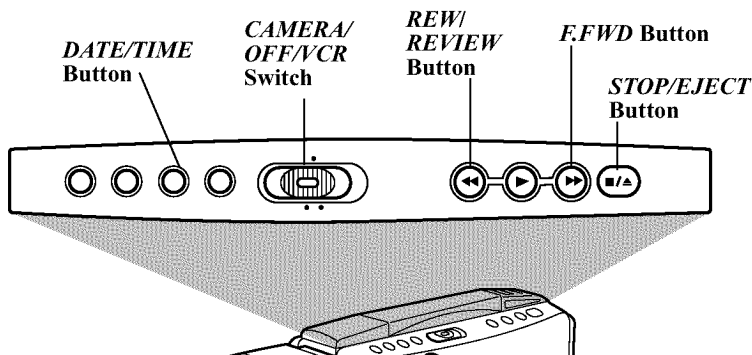

1. Attach a power supply to the camcorder.
2. Press and hold the small button on the *CAMERA/OFF/VCR* switch while you set it to *CAMERA*.
3. Press the *DATE/TIME* button to display the date and time in the viewfinder.
A flashing cursor lets you know which part of the display you are setting. If the flashing cursor does not appear, press and hold *DATE/TIME* and then press *STOP/EJECT*.
4. Repeatedly press the *F.FWD* or *REW/REVIEW* until the correct month appears. Press and hold the button to advance the digits faster.
5. When the correct month is displayed, press *STOP/EJECT*. The cursor moves to the next part of the display.
6. Repeat steps 4 and 5 to set the correct month, day, year, hour, minute(s), and *AM/PM*.
7. After setting *AM* or *PM*, press the *DATE/TIME* button to remove the flashing cursor and start the internal clock.

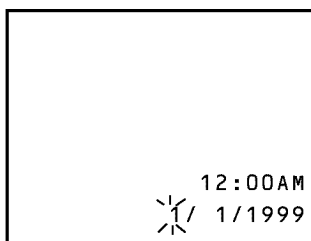

To Correct the Date or Time

To correct the date or time, press and hold the *DATE/TIME* button and then press *STOP/EJECT*. The display appears along with the flashing cursor. Use *STOP/EJECT*, *F.FWD*, and *REW/REVIEW* to correct the time or date. Press *DATE/TIME* to remove the flashing cursor and start the clock.

4. Repeatedly press the *F.FWD* or *REW/REVIEW* until the correct month appears. Press and hold the button to advance the digits faster.

Date and Time Display

Record the Time and Date, *AUTO* Date, Auto *TITLE*, or Date

The time and date, *AUTO* date, auto *TITLE*, date only, or no date can be recorded on your tape. Whenever one of these displays appear, it is recorded.

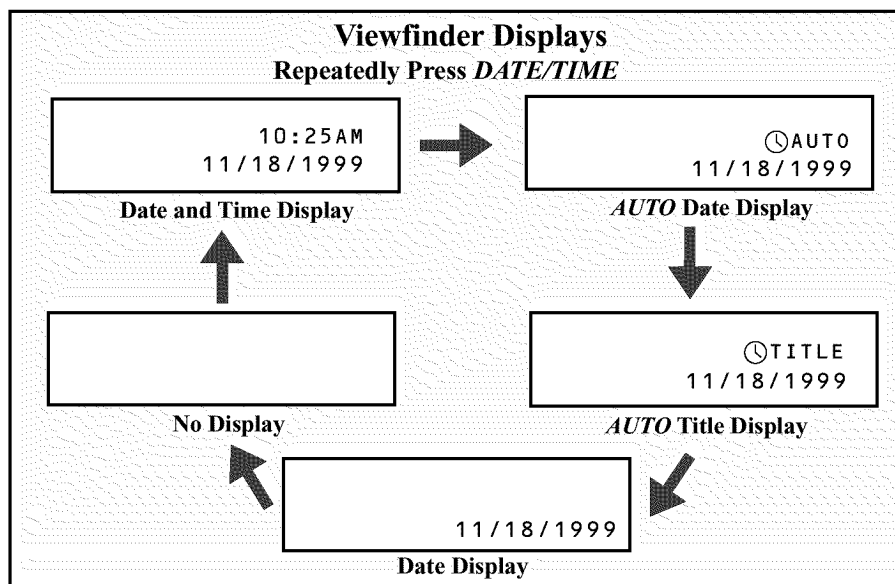

To Select the Display to Record

1. Repeatedly press *DATE/TIME* to select the display you want to record.
 - **Date and Time Display:** The date and time are displayed and recorded.
 - ⌚ **AUTO Date:** The date is automatically recorded for approximately ten seconds at the beginning of the recording.
 - ⌚ **TITLE:** The date and title you have created are displayed and recorded.
 - **Date Display:** The date is displayed and recorded.
 - **No Display:** No display is displayed or recorded.

Charge the Built-in Clock Battery

The camcorder has a built-in rechargeable battery **that must be charged approximately every two months.**

1. Attach a power supply and set the *CAMERA/OFF/VCR* switch to *OFF*.
2. Leave the power supply attached at least 24 hours.

Cautions: If this battery is not charged every two months, it will over-discharge and shorten its useful life.

Do not attempt to replace this battery. Take the camcorder to an authorized RCA Service Center.

Recording

Use the Viewfinder

The camcorder's viewfinder is a miniature monitor that displays the picture seen by the camcorder when recording.

Adjust Viewfinder for Convenient Viewing

For convenient viewing, rotate the viewfinder horizontally, pull it out from the camcorder, and adjust the eyepiece.

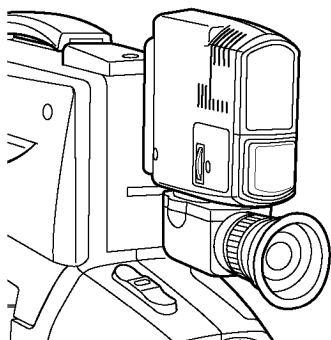

Viewfinder in Carrying or Storing Position

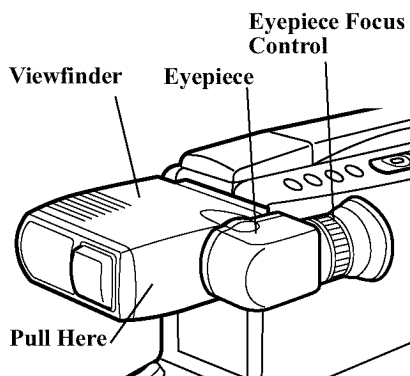

Viewfinder in Operating Position

Cautions: Do not pull on the eyepiece. Do not force the eyepiece to rotate completely around. This might damage the viewfinder and/or the camcorder.

When carrying the camcorder with the shoulder strap, put the viewfinder back in its original position. This helps prevent possible damage to the viewfinder from bumping against your body as you move.

Eyepiece Focus Control

The eyepiece focus control lets you set the focus of the viewfinder for your vision. If you wear eyeglasses, you probably can operate the camcorder without them.

It is easiest to set the correct focus by focusing on one of the viewfinder's on-screen displays. Look through the

viewfinder and adjust the eyepiece focus control for your vision.

The eyepiece focus control does not affect the focus of the picture actually recorded by the camcorder.

Recording

Use the Viewfinder (continued)

Tilt Adjustment

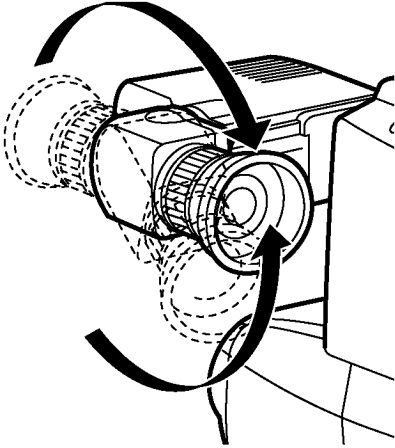

Cautions: Do not pull on the eyepiece. Do not force the eyepiece to rotate completely around. This might damage the viewfinder and/or the camcorder.

*BRIG*T Control

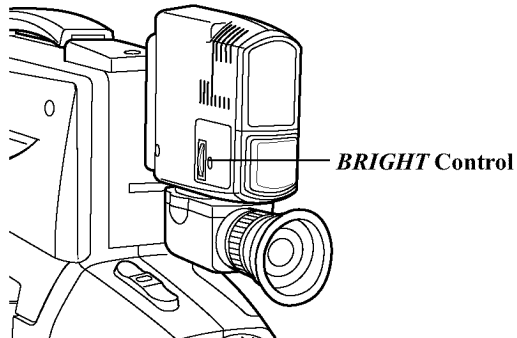

The brightness of the viewfinder can be adjusted by rotating the *BRIG*T control. This does not affect the picture being recorded by the camcorder.

Viewfinder Displays

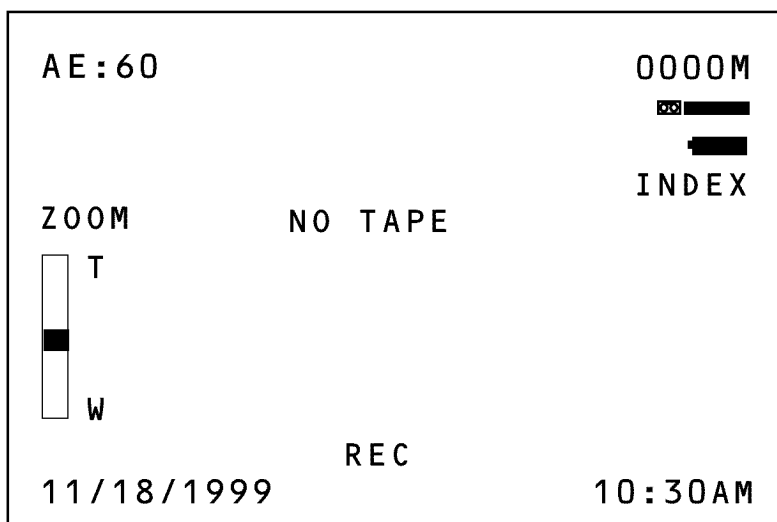

AE:60 (Auto Exposure) Shutter Speed

Press the *DISPLAY* button to display the shutter speed selected by the camcorder.

Battery Level Indicator (■)

Press the *DISPLAY* button to display the amount of time left on the rechargeable battery. *Details are on page 13.*

INDEX Indicator

Press the *DISPLAY* button to display this indicator when the camcorder is placing an index mark on the tape. *Details are on page 26.*

Status Displays

The following displays appear to tell you the status of the camcorder.

- The *REC* indicator appears during recording.
- The ►► indicator appears when the camcorder is fast-forwarding.
- The ◀◀ indicator appears when the camcorder is rewinding.
- The || indicator appears during record-pause.

Viewfinder Displays *(continued)*

Tape Counter (0000M) with Memory Stop

Press the *DISPLAY* button to display the tape counter. The tape counter helps locate segments of tape.

- Whenever the tape counter is displayed, the memory-stop feature turns on.
- *Details are on page 28.*

Tape Warnings (*TAPE*, *NO TAPE*, and *TAPE END*)

- *TAPE* flashes when you try to record with the safety tab removed.
- *TAPE* flashes when a damaged tape is inserted. Remove the tape and replace it with a new one.
- *NO TAPE* flashes when you try to record with no cassette inserted.
- *TAPE END* flashes when there is approximately five minutes recording time left on the tape.
- *TAPE END* briefly appears when you reach the end of the cassette during recording.

Time and Date Display

Press the *DATE/TIME* button to display the time and date, *AUTO* date, auto *TITLE*, date only, or no date when the camcorder is in record-pause.

- These displays are recorded on the tape when they appear in the viewfinder.
- *Details are on pages 18-19.*

Tape-Remaining Indicator (∞—)

Press the *DISPLAY* button to display the tape-remaining indicator. This display shows the approximate amount of tape left for recording or playback. *Details are on page 26.*

Zoom () and ZOOM Indicators

- The zoom indicator () appears when you use the power zoom buttons (*T* and *W*).
- *ZOOM* appears when you zoom more than 16 times.
- *Details are on pages 27.*

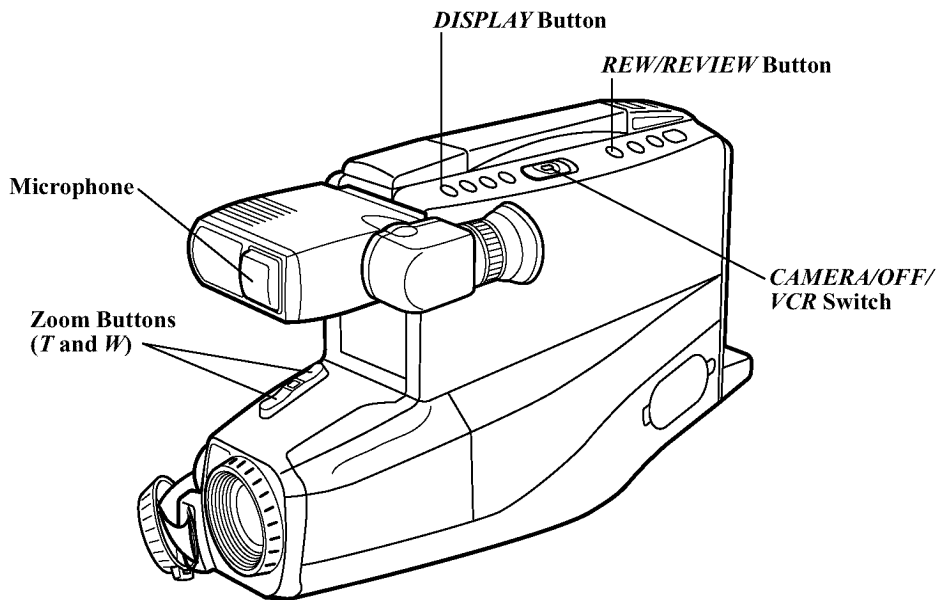

***DISPLAY* Button**

The *DISPLAY* button lets you remove the battery level, tape counter with memory stop, tape speed, remaining-tape, index, shutter speed, and zoom indicators from the viewfinder.

- Press *DISPLAY* to remove the indicators.
- Press *DISPLAY* again to display the indicators.

Quick Review Feature

Press and release *REW/REVIEW* when the camcorder is in record-pause to review the last few seconds of a recording. The *CAMERA/OFF/VCR* switch must be set to *CAMERA*.

The camcorder plays back the last few seconds of the recording, returns the tape to its previous position, and returns to record-pause.

Camera Edit Feature

The camera edit feature allows you to position the tape when the camcorder is in record-pause. Press and hold the small button while you set the *CAMERA/OFF/VCR* switch to *CAMERA*.

- Press and hold *REW/REVIEW* to visually search the recorded tape in reverse.
- Press and hold *FFWD* to visually search forward on the recorded tape.
- Press and hold *PLAY* to view the recorded tape at normal speed.

When you release the button, the camcorder returns to record-pause at that point on the tape.

Auto Shot™ Feature

The camcorder automatically adjusts shutter speed, light, focus, white balance, and iris according to the recording conditions.

Microphone

The microphone picks up the sound during a recording. It is more sensitive to sounds coming from the direction the lens is pointed.

Auto Focus

The camcorder focuses on the subject in the center of the viewfinder. Auto focus operates on the telephoto (*T*) side from approximately 2-1/2 feet to infinity. It operates on the wide-angle (*W*) side from 3/8 inch from the lens surface (macro-focus) to infinity.

Note: When the displays appear, the *AE* indicator for the shutter speed selected by the camcorder (*1/60, 1/100, 1/120, 1/180, 1/250, 1/350, 1/500, 1/750, 1/1000, 1/1500, 1/2000, or 1/4000*) appears in the viewfinder.

The following conditions may prevent auto focus from operating properly.

- Recording a subject through a window.
- Recording a subject having a close foreground and a far background.
- Recording two subjects at different distances that overlap.
- Subject not in center of scene.
- Recording in low-light situations.
- Recording a scene with fast motions, like a tennis swing.

Macro Focus

The macro-focus feature lets you focus on objects as close as 3/8 inch from the camcorder lens.

1. Press and hold zoom button *W* until the lens is completely zoomed out.
2. Position the subject in the center of the scene.

Notes: Zooming is not possible when using macro-focus. To change the size of the subject, move the camcorder lens closer or farther away from it.

For best results increase illumination when recording with macro-focus.

Recording

Tape-Remaining Display

The tape-remaining display shows the amount of recording or playback time left on the tape in the camcorder.

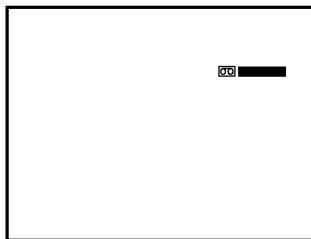



**Tape-Remaining Display
in Viewfinder**

- Press *DISPLAY* to display the tape-remaining indicator in the viewfinder.
- The camcorder takes approximately ten seconds when you first start playing or recording a tape to calculate the tape remaining.

“_ _ _ _ _” appears while the camcorder calculates the amount of tape remaining.

Once the amount of tape remaining is calculated, it updates and is readily available as long as the same tape remains in the camcorder.

- When  appears, all or most of the tape remains.
- As the tape is used,  and  appear.
- When the tape is almost at its end, *TAPE END* flashes in the viewfinder.

Electronic Indexing

Each time you begin recording (after the camcorder has been turned off for at least four hours), the camcorder automatically records an index mark at the beginning of the new recording.

When you play back the indexed tape in a VCR that has a compatible indexing feature called “VHS Index Search System”, the invisible marks are located automatically. See your VCR Owner’s Manual for index playback instructions.



***INDEX* Display
in Viewfinder**

When the *DISPLAY* button is pressed so the displays appear, *INDEX* appears briefly to let you know the camcorder is recording an index mark.

Note: The camcorder does not record index marks every time you stop and start recording. An index mark is recorded only once – at the start of each day’s recording session (or whenever the camcorder has been turned off for four hours).

Recording

Zooming

You can zoom in and out for close ups or wide-angle shots by pressing one of the zoom buttons on the camcorder.

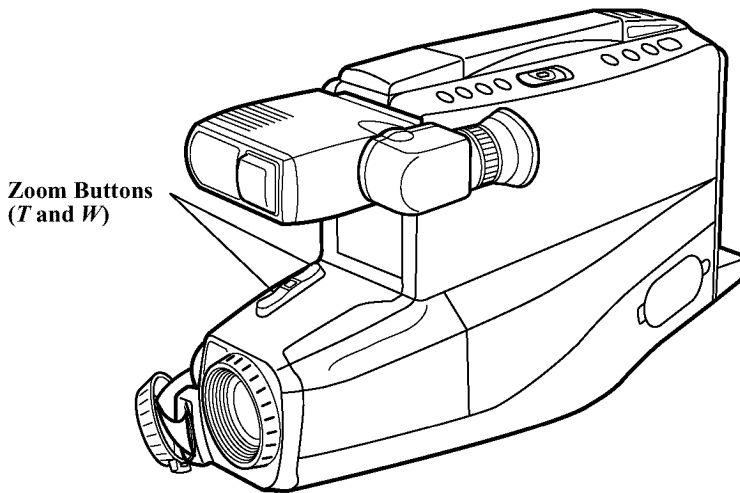

**Zoom Buttons
(*T* and *W*)**

Use the Zoom Buttons (*T* and *W*)

1. To zoom in or out from wide angle to 72 times, press zoom button *T* or *W*.
 - To move the lens in the telephoto (close-up) direction, press *T*.
 - To move the lens in the wide angle direction, press *W*.

When you press *DISPLAY* so the displays appear, the zoom level indicator appears in the viewfinder during normal zooming.

When you zoom in more than 16 times, *ZOOM* appears in the viewfinder.

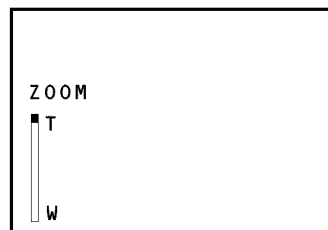

**Zoom Indicators
in Viewfinder**

Recording

Tape Counter

The tape counter acts as a handy reference to help you locate tape segments. The memory-stop feature helps locate a certain point on the tape. When the tape counter appears, memory stop is automatically turned on.

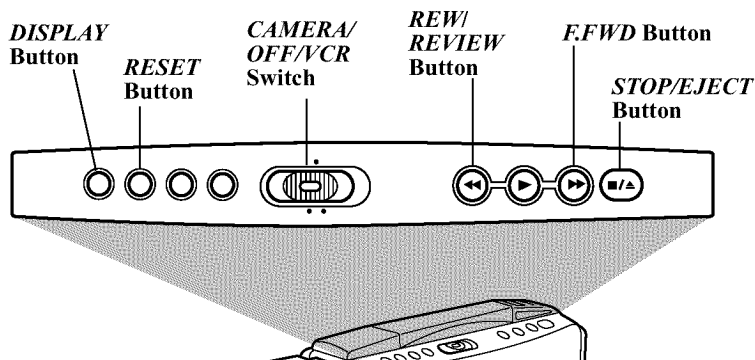

Use the Memory-Stop Feature

1. Place the camcorder in record-pause. Make sure the displays appear in the viewfinder. If they do not, press *DISPLAY*.
2. Locate the place on the tape you want to return to, and press *RESET* to reset the counter to *0000M*.
3. Continue to record or play the tape. When you want to return to the place you marked, press the *REC/PAUSE* button to stop recording or the *STOP/EJECT* button to stop playback.
4. Press and hold the small button while you set the *CAMERA/OFF/VCR* switch to *VCR*.
5. Press the *REW/REVIEW* button. The tape rewinds to the counter reading of *0000M*.

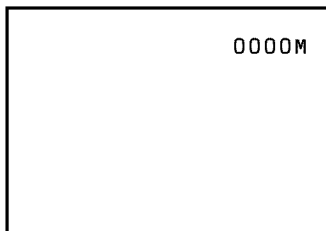

**Tape Counter With
Memory Stop**

3. Continue to record or play the tape. When you want to return to the place

Notes: Press *DISPLAY* to display the tape counter. Whenever the tape counter is displayed, memory stop is turned on. Whenever memory stop is turned on, the camcorder stops rewinding or fast forwarding when the counter reaches *0000M*. To continue rewinding or fast forwarding, press the button again.

The tape counter automatically resets to *0000M* whenever a cassette is inserted.

Recording

Recording Tips

- Try to make sure indoor scenes are well-lit. This improves picture quality and color reproduction.
- Do not move the camcorder rapidly from side-to-side while recording. A steady, gradual “pan” avoids blurring and “jitter”.
- Use the viewfinder to make sure the camcorder is level while recording so that your scene isn’t “tilted”.
- Do not bump or tap the camcorder’s microphone while recording because this sound is recorded.
- Include close-ups of individuals when taping family outings or group functions.
- Be aware of video and audio backgrounds. Background details barely noticed while you are taping might show up as visual “clutter” on your recording. Background noises (especially TV sets, radios, household appliances, traffic sounds, etc.) might detract from the sound you want to record.
- Avoid long “still” shots of landmarks and scenic attractions. Recordings are more interesting if they include people and details. “Local color” will give travel videos lasting appeal. Consider recording a familiar or landmark scene from an unfamiliar vantage point.

Travel Tips

- Write down your camcorder’s serial number and keep it separate from the camcorder when traveling. If your camcorder is lost or stolen, you will be able to identify it.
- Use extra care to avoid damage to your camcorder and accessories when operating them at a beach or pool. Spray, sand, and dust should be avoided. If your lens has been exposed to the elements, clean it only with proper lens cleaning supplies.
- Make sure you have any adapters that you may need before taking your camcorder to other countries. Consult your dealer for advice.
- Carry your camcorder in a carrying case when traveling. *See page 41* for a case designed especially for this camcorder. An ordinary suitcase or carry bag does not offer the protection your camcorder needs. Treat your camcorder as carry-on luggage to protect it from rough handling.

Recording

Titler

The camcorder's built-in titler stores a title in memory. You can display and record the created title at any time.

The built-in character register contains over 45 different characters for creating your titles. The title can contain up to 32 characters on two lines.

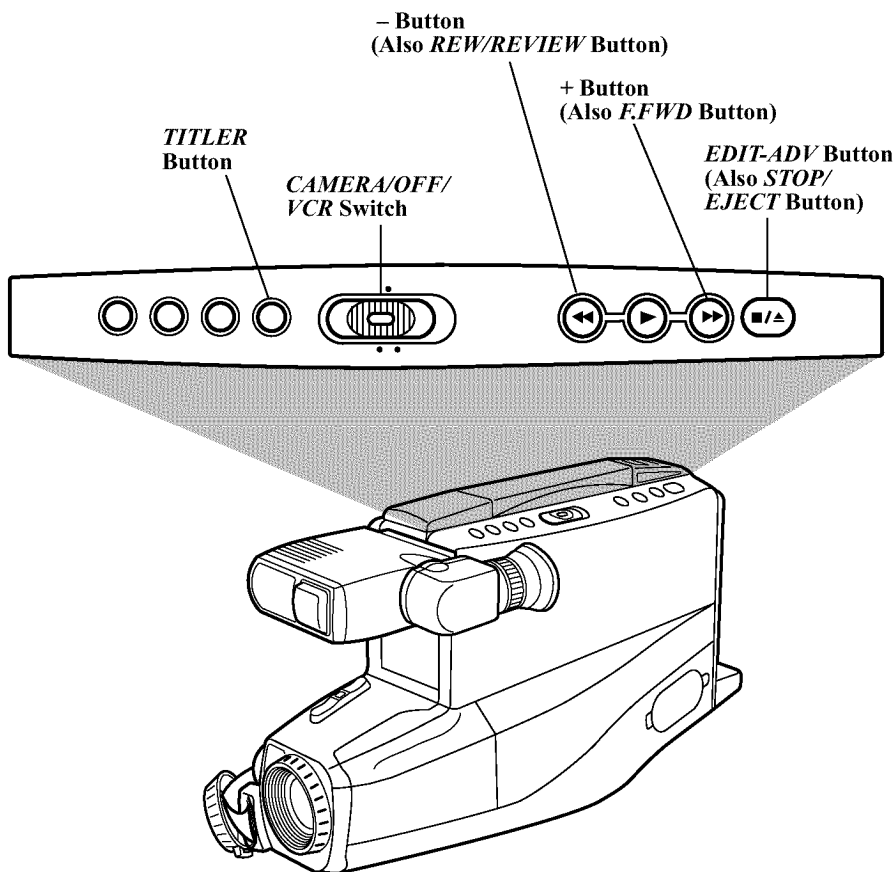

Titler *(continued)*

To Create a Title

1. Attach a power source to the camcorder. Press and hold the small button on the *CAMERA/OFF/VCR* switch while you set it to *CAMERA*.
2. Press *TITLER* to display the titler graphics in the viewfinder. A flashing cursor appears.
3. Press *EDIT-ADV* to move the flashing cursor to the place you want to begin your title.
4. Select the first character for your title by pressing the + or – button until the character you want appears in the viewfinder.
5. After you have selected the first character, press *EDIT-ADV* to move the flashing cursor where you want the next character to appear.
6. Repeat steps 4 and 5 until you have completed the title.
7. When you are finished, press *TITLER* to store the title and remove the title graphics from the viewfinder.

See the chart below for the characters available.

Remember: Remove the titler graphics from the viewfinder for normal recording.

To Correct an Error

1. Press *TITLER* to display the titler graphics in the viewfinder.
2. Press *EDIT-ADV* to move the flashing cursor over the character you want to correct.
3. Press the + or – button until the correct character appears.

Note: If you want to delete a character, press + or – until the blank space appears.

Chart of Characters in Titler's Register

A	B	C	D	E	F	G	H	I	J	K	L	M
N	O	P	Q	R	S	T	U	V	W	X	Y	Z
0	1	2	3	4	5	6	7	8	9	?	'	. / ,
–	;	:	<	>	!	(BLANK)						

(Continued on next page)

Titler (*continued*)

Record a Title on a Tape in the Camcorder

1. Attach a power source to the camcorder. Press and hold the small button on the *CAMERA/OFF/VCR* switch while you slide it to *CAMERA*.
2. Locate the place on the tape where you want to record the title.

Note: If you record a title on a prerecorded tape, the audio and video is erased where the title is inserted. There will also be a three-to-four second pause of blank tape before the existing audio and video return.

3. Press *TITLER* to display the titler graphics in the viewfinder.
4. Press *REC/PAUSE* to start recording the title.
5. After you have recorded the title for the desired length of time, press

TITLER to remove the titler graphics from the viewfinder. The camcorder now records normally. If you do not want to continue recording, press *REC/PAUSE*.

Remember: Remove the titler graphics from the viewfinder for normal recording.

Note: You can use the *AUTO* title feature to automatically record the title and date for ten seconds when you begin recording. Press the *DATE/TIME* button to display  *TITLE* before starting to record.

Record a Title While Copying a Tape from the Camcorder to Another VCR

1. Attach a power source to the camcorder.
2. Place the tape you want to copy in the camcorder and place the *CAMERA/OFF/VCR* switch in *VCR*.
3. Place a blank tape in the VCR, and place the VCR in record-pause.
4. Start copying the tape from the camcorder to the VCR. *Details are on pages 36-37.*
5. When you see the place on the tape you want to insert the title, press *TITLER*.

6. After you have recorded the title for the desired time, press *TITLER* to stop recording the title.
7. Stop the camcorder and VCR when you finish copying the tape.

Important Note: Remove the titler graphics from the viewfinder for normal recording.

Viewfinder Playback

Viewfinder playback is the simplest way to watch tapes using the camcorder.

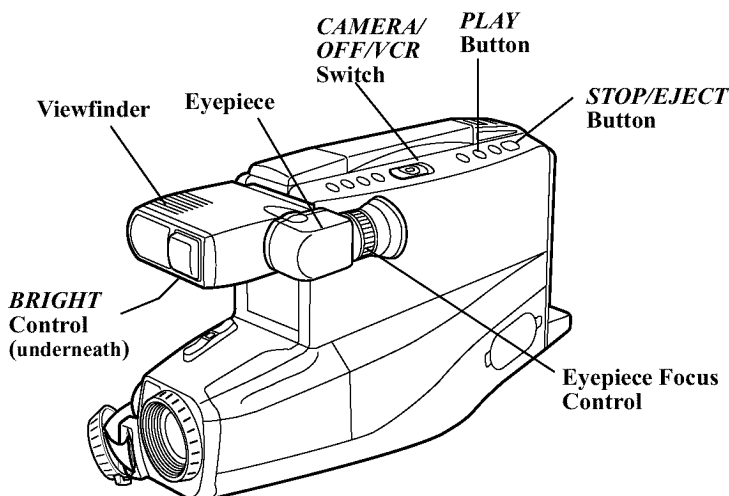

To Play Back a Tape

1. Attach a power supply.

Attach the adapter/charger, charged battery, or optional car cord.

2. Insert a tape.

- Press *STOP/EJECT* to open the cassette compartment.
- Insert the cassette with the safety tab facing up and the tape windows facing out. Press the cassette down gently until it locks into place, and close the cassette compartment door.
- The camcorder only plays back tapes recorded in the SP speed.

3. Press and hold the small button on the *CAMERA/OFF/VCR* switch while you slide it to *VCR*.

4. Adjust the viewfinder.

- Grasp the viewfinder and rotate it horizontally. Pull the viewfinder out from the camcorder and rotate the eyepiece into a comfortable viewing position.

Caution: Pulling on the eyepiece might cause damage to the eyepiece or camcorder.

- Turn the eyepiece focus control to adjust the focus of the viewfinder for your vision.
- Rotate the *BRIGHT* control to adjust the brightness.

5. Press *PLAY* to begin playback.

- If necessary, adjust tracking.
- During playback, use the playback features *on the following page*.

6. Press *STOP/EJECT* when you are finished.

Playback

Playback Features

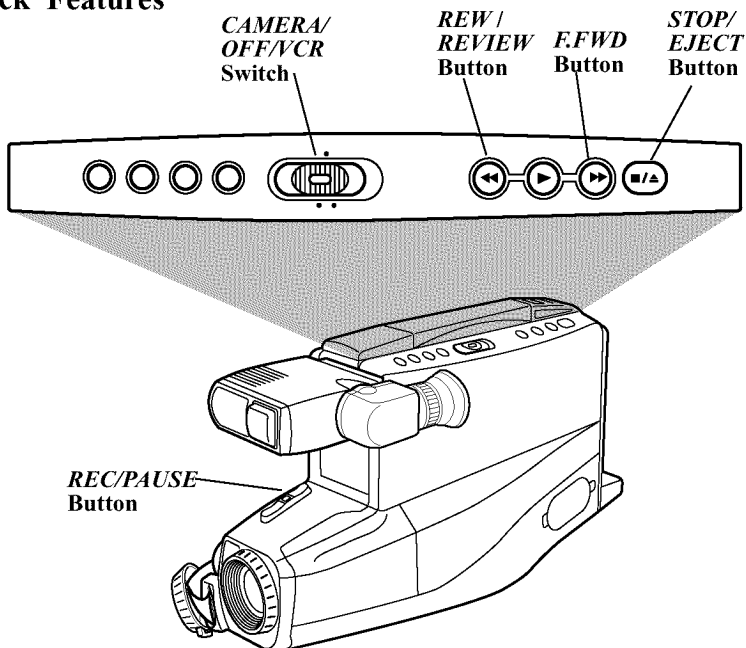

Tape Positioning

Press and hold the small button on the *CAMERA/OFF/VCR* switch while you slide it to *VCR*.

- Press and quickly release *REW/REVIEW* or *F.FWD* to rewind or fast-forward the tape.
- Press *STOP/EJECT* to stop the tape.

Visual Searching

- During playback, press and hold *F.FWD* or *REW/REVIEW* if you want to search the tape visually in forward or reverse.
- Release the button to return to normal playback.

Stop-Action Pause

- During playback, press *REC/PAUSE* to “stop the action” and view one frame of the tape.
- Press *REC/PAUSE* again to return to normal playback.

Caution: Pause is designed for momentary interruptions and should not be used for an extended period of time. If the camcorder remains in pause for more than five minutes, it enters the stop mode and turns off to prevent excessive tape wear.

Playback Features *(continued)*

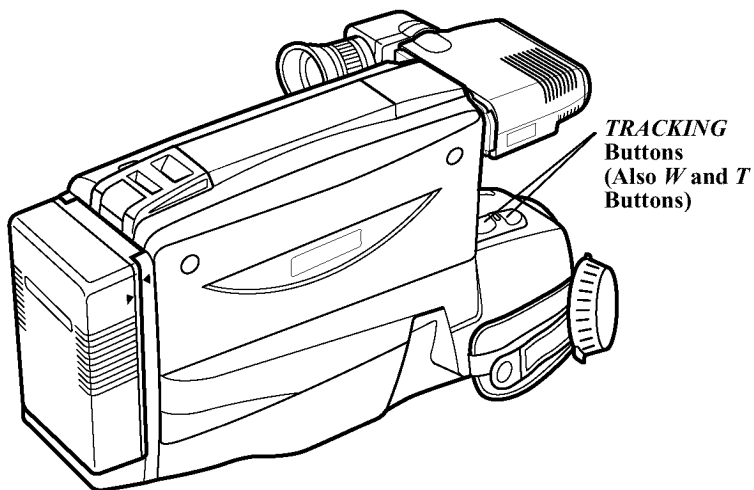

Tracking

During playback, streaks might appear in the playback picture. Press either *TRACKING* button to move the streaks up or down and out of the picture.

- During stop-action playback, pressing one tracking button might reduce picture “jitter” (picture bouncing up and down). Some “jitter” is normal.

Remove the tape to reset the tracking to its preset center.

Note: The tracking buttons only affect tape playback. They have no effect during recording.

Playback

Playback on TV (or VCR) with Audio/Video Inputs

To connect your camcorder to a TV monitor (or VCR) with audio and video inputs, you need an optional audio/video cable, such as VH83 *shown on page 43*. If your TV is already connected to a VCR, attach the camcorder to the VCR and watch what the camcorder is recording or playing on the TV.

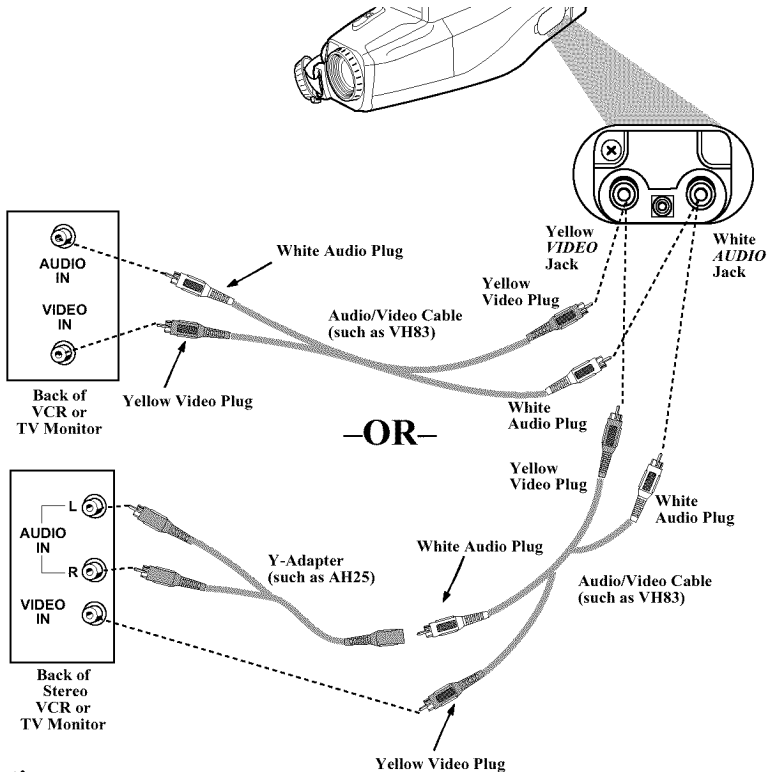

Installation

1. Attach the white plug on one end of the audio/video cable to the **AUDIO IN** jack on the TV (or VCR).
2. Attach the yellow plug to the **VIDEO IN** jack on the TV (or VCR).
3. Attach the white plug on the other end of the audio/video cable to the **AUDIO** jack (located under the small cover) on the side of the camcorder.
4. Attach the yellow plug to the yellow **VIDEO** jack on the camcorder.

Notes: If your cable does not have white and yellow plugs, attach the same color to the audio jacks.

If your TV (or VCR) has stereo **AUDIO IN** jacks, attach the plug to the one labeled **MONO**. If one is not labeled **MONO** you need a Y-adapter, such as AH25, *shown on page 43* to hear both channels.

Playback Operation and How to Copy Tapes on the VCR

1. A. Camcorder connected directly to TV: Turn on the TV and tune it to the video input channel.
- B. Camcorder connected to VCR that is already connected to TV: Turn on VCR and place it in the “line” or “camera mode”. (If your VCR does not have a “line” or “camera mode”, consult the VCR owner’s manual.) Operate the TV as you normally do to see the signal coming from the VCR.
2. Press and hold the small button on the *CAMERA/OFF/VCR* switch while you slide it to *VCR*.
Note: The camcorder only plays back tapes recorded in the SP speed.
3. Press *PLAY*.
 - During playback, use the playback features on pages 34-35.
4. To copy what the camcorder is playing, place a blank cassette in the VCR, and press the VCR’s *RECORD* button.
Note: Make sure the memory-stop feature is turned off (press *DISPLAY*) or the camcorder will enter play-pause when the counter reaches *0000M*.
5. Press *STOP/EJECT* when you are finished.

Viewing What the Camcorder is Seeing (or Recording)

1. A. Camcorder connected directly to TV: Turn on the TV, and tune it to the video input channel.
- B. Camcorder connected to VCR that is already connected to TV: Turn on VCR and place it in the “line” or “camera mode”. (If your VCR does not have a “line” or “camera mode”, consult the VCR owner’s manual.) Operate the TV as you normally do to see the signal coming from the VCR.
2. Press and hold the small button on the *CAMERA/OFF/VCR* switch while you slide it to *CAMERA*.
Note: Turn the TV’s volume down to prevent a high-pitched squeal caused by feedback.
3. Press the *REC/PAUSE* button to begin recording. You can watch what the camcorder is seeing (or recording) on the TV screen.

Caution: The unauthorized recording of copyrighted material may infringe the rights of others.

Playback

Playback on a TV Without Audio/Video Inputs

To connect your camcorder to a TV without audio/video inputs, you need an optional CRF95 RF output adapter and an optional coaxial RF cable, such as VH82 or VH90 *shown on page 43*. If your TV has audio and video inputs (or is connected to a VCR), refer to pages 36-37.

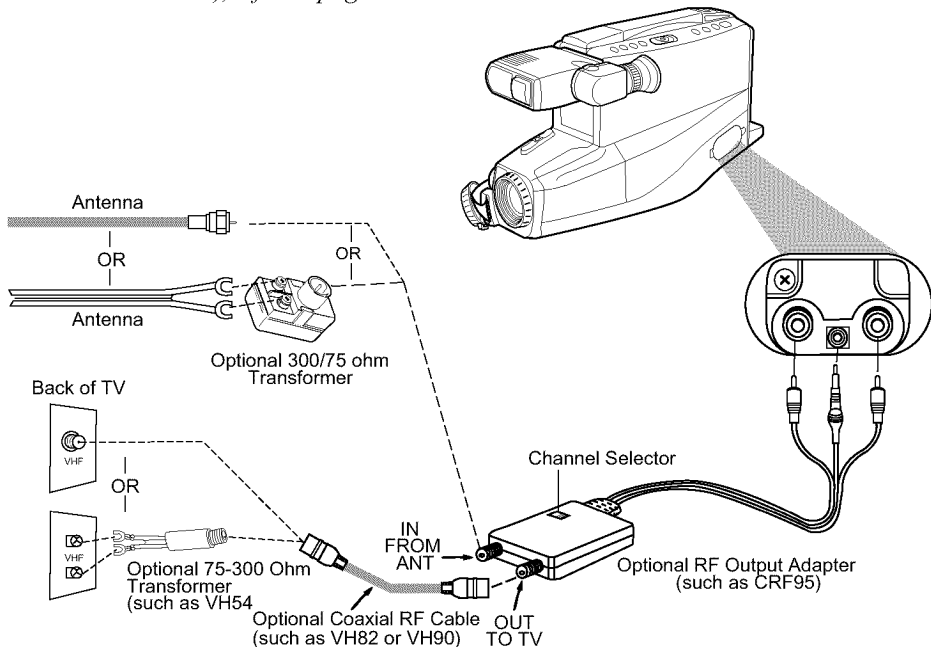

Installation

1. Disconnect the VHF antenna from your TV. Connect the antenna to the *IN FROM ANT* connector on the RF output adapter if you are going to leave the adapter connected to the TV.

Note: If your VHF antenna is the flat twin-lead type attached by two screws, you need an optional 300/75 ohm transformer.

2. Attach one end of the optional coaxial RF cable to the *OUT TO TV* connector on the adapter, and attach the other end to the VHF input on your TV *as shown*.

Note: If your TV has 300 ohm screw terminals, you need a 75/300 ohm transformer, such as VH54, *shown on page 43*.

3. Attach the RF output adapter's yellow plug to the *VIDEO* jack, the small plug to the *RF DC OUT* jack, and the white plug to the *AUDIO* jack located under the small cover on the side of the camcorder.

Playback

Playback Operation

1. Set the *CH3/CH4* switch on the RF output adapter to channel *CH3* or *CH4*.
2. Turn on the TV, and tune it to the same channel you selected with the RF output adapter's *CH3/CH4* switch.
3. Press and hold the small button on the *CAMERA/OFF/VCR* switch while you slide it to *VCR*.
4. Press *PLAY* on the camcorder.
 - During playback, use the playback features *described on pages 34-35*.
5. Press *STOP/EJECT* on the camcorder when you are finished.

Viewing What the Camcorder Is Recording

1. Turn on the TV and tune it to channel 3 or 4. Turn the TV's volume down to prevent a high-pitched squeal caused by feedback.
2. Set the *CH3/CH4* switch on the RF output adapter to the same channel you selected on the TV.
3. Press and hold the small button on the *CAMERA/OFF/VCR* switch while you slide it to *CAMERA*.
4. Press the *REC/PAUSE* button to begin recording. You can watch what the camcorder is seeing (or recording) on the TV screen.

Normal TV Viewing

For normal TV viewing, leave the RF output adapter hooked up to the TV. Disconnect the adapter's plug from the camcorder or turn the camcorder's power off.

Note to Cable TV Installer

This reminder is provided to call your attention to Article 820-40 of the National Electrical Code (Section 54 of Canadian Electrical Code, Part I), that provides guidelines for proper grounding and, in particular, specifies that the cable ground shall be connected to the grounding system of the building as close to the point of cable entry as practical.

Attach the Shoulder Strap

The camcorder's shoulder strap is designed to let you carry the camcorder from your shoulder and – when you are ready to shoot – bring the camcorder to shooting position in one quick movement.

To Attach the Shoulder Strap

1. Unfasten one end of the shoulder strap from the buckle. Make sure you leave the buckle on the strap.

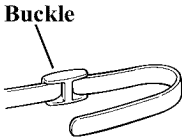

3. Thread the end of the strap back through the buckle making sure it is threaded over the outer strap. Make sure the strap is not twisted.

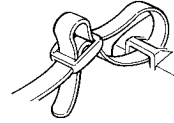

2. Thread one end of the shoulder strap through one of the shoulder strap rings as shown below.

Shoulder Strap Attachment Ring

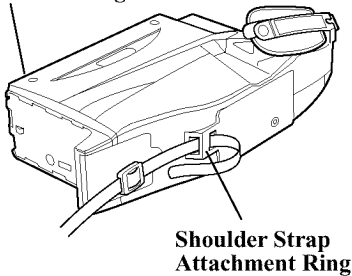

4. Repeat steps 1-3 to attach the other end of the strap.
5. Pull on the straps and make sure they are securely fastened before you use the shoulder strap to support your camcorder.

Cautions: Rotate the viewfinder up to its original position when you carry the camcorder with the shoulder strap. This helps prevent possible damage to the viewfinder or monitor from bumping against your body as you move.

Make sure the shoulder strap is firmly attached before using it to carry the camcorder.

Optional Accessories

We invite you to take a look at some great ideas for sparking creativity and adding to the fun of using your VHS camcorder. The following pages have a selection of accessories to help make your memorable moments look and sound even better.

These accessories are designed to make the process of recording and watching your videos more enjoyable.

To order accessories, contact your local Dealer.

If a dealer is not nearby, all accessories are available through toll-free ordering or by using the order form *on page 45*.

AC202 Soft Carrying Case

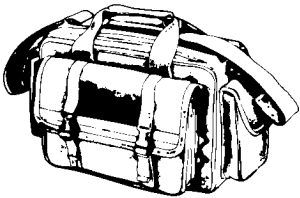

This case provides protection and utility for full size camcorders and most accessories. It is constructed of rugged nylon fabric for years of reliable service.

Three outside pockets provide ample accessory storage with mesh-covered lens filter compartment and built-in holders for memo pads, pens, and other accessories. The hand grip and adjustable shoulder strap allow for convenient, comfortable transportation of the camcorder.

DCC096 DC Car Cord Adapter

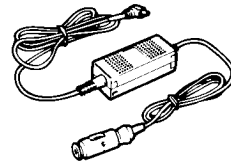

Do not use any other car cord with this camcorder.

This car cord adapter enables you to operate your camcorder from your car, truck, or RV by plugging the car cord directly into the vehicle's cigarette lighter socket. The DCC096 is designed specifically to convert power from a 12-volt battery to a 9.6-volt output.

Optional Accessories

EP096FS and EP096FL Rechargeable Batteries

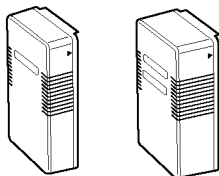

These rechargeable lead-acid batteries are designed specifically for long life. The EP096FS is a 1-hour battery. The EP096FL powers your camcorder twice as long as the EP096FS (depending on how much you turn the camcorder on and off and use zoom and pause). Both can be recharged with the AC adapter/charger that came with your camcorder.

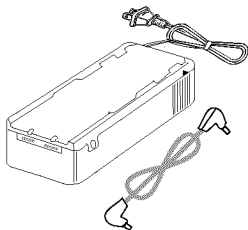

CPS014 AC Battery Charger

The CPS014 battery charger plugs directly into an AC outlet and charges the EP096FS and EP096FL camcorder batteries. Because the CPS014 operates on 100-240 Volts, 50/60 Hz, you can use it virtually anywhere in the world. A plug adapter might be required in some countries.

All specifications and descriptions of accessories are subject to change without notice.

Using the Optional AC093 Tripod

Mounting the camcorder on a tripod, such as AC093, keeps the camcorder steady and produce excellent video results.

This tripod's fluid-effect head provides smooth camera pan and tilt. The quick-release mount makes it easy to attach or remove the camcorder. The grooved, tubular 3-section leg design folds down to 24" when not in use. Rubber feet allow for sure footing and built-in retractable leg spikes eliminate the need for removing the feet.

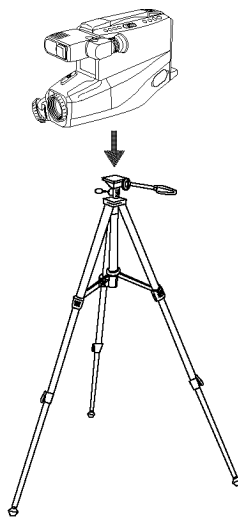

Caution: Before using a tripod, make sure it is stable enough to hold the camcorder without falling over. Do not transport the camcorder attached to the tripod.

When attaching your camcorder to a tripod, be careful not to force the tripod screw into the camcorder's tripod mounting hole.

The tripod screw should not protrude into the camcorder more than approximately three-eighth (3/8) inch. Forcing the screw could damage the mounting hole on the bottom of the camcorder.

Optional Accessories

CRF95 RF Output Adapter

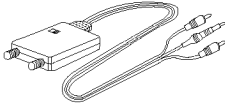

This RF output adapter is used with a coaxial RF cable, such as VH82 or VH90, to connect your camcorder to a standard TV (one without audio/video inputs) for playback. If your antenna cable is the flat twin-lead type attached by two screws, you need a 300-to-75 ohm transformer. If your TV has 300 ohm antenna screw terminals, you need an optional 75-to-300 ohm transformer such as VH54.

Coaxial RF Cables

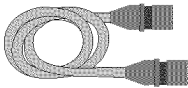

VH82 (6-ft)
VH90 (12-ft)

These RF cables are used with the RF output adapter to connect your camcorder to a standard TV (one without audio/video input jacks) for playback. If your TV has 300 ohm antenna screw terminals, you need an optional 75-to-300 ohm transformer, such as VH54. If your antenna cable is the flat twin-lead type attached by two screws, you need an optional 300-to-75 ohm transformer.

VH54 Cable Transformer

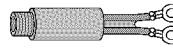

This 75-to-300 ohm transformer is used to connect a standard 75-ohm antenna cable (such as VH82 or VH90) to the 300 ohm screw terminals on a TV.

VH83 Audio/Video Cable

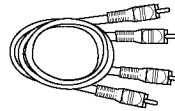

This six foot audio/video cable can be used to connect the camcorder to a TV monitor or VCR for tape playback or copying tapes.

AH25 Y-Adapter



This Y-adapter allows you to connect your camcorder's mono audio cable to a stereo TV or VCR.

All specifications and descriptions of accessories are subject to change without notice.

Optional Accessories

Remove the Lens Hood

The lens hood can be removed so you can attach optional accessories, such as wide-angle lens, lens extenders, or lens filter kits.

To Attach an Accessory Lens

1. Attach the lens cap over the lens hood.
2. Turn the lens cap and hood counterclockwise with the palm of your hand to remove them.
3. Turn the accessory lens clockwise into the camcorder's lens. Make sure the lens is tightened firmly, but do not over tighten.

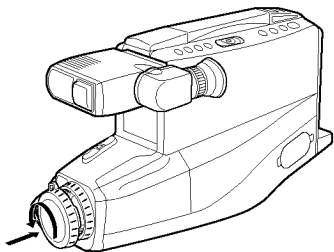

2. Turn the lens cap and hood counterclockwise with the palm of your hand to remove them.

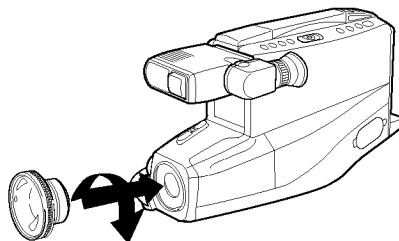
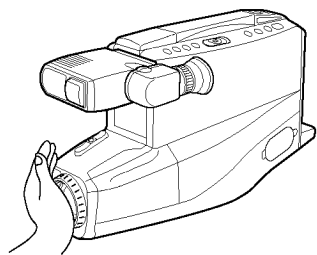

All specifications and descriptions of accessories are subject to change without notice.

Caution: Do not grasp the end of the lens hood.

Accessory Order Form

Order Form for Camcorder Model CC4252

Description	Part No.	Price	Qty.	Total
Deluxe Tripod	AC093	\$ 59.95		
Soft Camcorder Case	AC202	\$ 49.95		
Y-Adapter	AH25	\$ 2.95		
AC Adapter/Charger (100-240V)	CPS014	\$219.95		
RF Output Adapter	CRF95	\$ 69.95		
Car Cord Adapter	DCC096	\$ 49.95		
Rechargeable Battery (Extended)	EP096FL	\$ 79.95		
Rechargeable Battery (Standard)	EP096FS	\$ 69.95		
75-300 Cable Transformer	VH54	\$ 2.95		
Coaxial RF-Cable	VH82	\$ 6.95		
Audio/Video Cable	VH83	\$ 5.95		
Coaxial RF-Cable	VH90	\$ 7.95		
Shoulder Strap	241305	\$ 12.95		
AC Adapter/Charger (Supplied)	241044	\$169.95		
DC Cable	23328	\$ 13.65		

Total Merchandise \$ _____

Sales Tax \$ _____

We are required by law to collect the appropriate sales tax for each individual state, county, and locality to which the merchandise is being sent.

Shipping and Handling \$ **5.00**

Total Amount Enclosed \$ _____

Use VISA, MasterCard, or Discover.

Money order or check must be in U.S.

currency only. No COD or cash.

Prices are subject to change without notice.

Detach Here



Please complete other side also



Accessory Order Form

Charge your order on your VISA, MasterCard,
or Discover Card by filling in below

USE YOUR CREDIT CARD

IMPORTANT: Copy complete account number from your VISA card

Expiration date:



IMPORTANT: Copy complete account number from your MasterCard

Expiration date:



IMPORTANT: Copy complete account number from your Discover Card

Expiration date:



AUTHORIZED SIGNATURE

Prices are subject to change without notice.

Print or type your name and
address clearly.



A complete and correct order will
save you days of waiting.

Name: _____
Street: _____
_____ Apt: _____
City: _____
State: _____ Zip: _____

Please make sure that both sides of this form have been filled out completely.

- Allow 4 weeks for delivery.
- All accessories are subject to availability.

Detach Here 

Accessory Order Form

To order accessories, contact your local Dealer.

If a dealer is not nearby, you can also follow the directions below to order by telephone or direct-by-mail.

United States and Canada Orders

To place your order by phone, have your Visa, MasterCard, or Discover card ready and call the toll-free number listed below between 8 AM and 10 PM (EST) Monday through Friday or between 9AM and 5PM (EST) Saturday.

Use this number only to place an order for accessory items listed on this order form.

1-800-338-0376

To place your order by mail, detach and mail the completed order form with credit card information, money order, or check in U.S. currency (made payable to Thomson Consumer Electronics, Inc.) to the following address:

Video Accessories
PO Box 8419
Ronks, PA 17573



Trouble Checks

If you're having trouble with your camcorder, you probably can correct the problem yourself. Before you take your camcorder to an Authorized RCA Camcorder Service Center or call a service person, use the chart below. Find the problem and try the adjustment(s) that is listed to the right.

If service should be necessary, read your warranty to find out what is covered and how to get service.

Trouble	Checks and Adjustments
No power	<ul style="list-style-type: none">• Press and hold the small button while you place the <i>CAMERA/OFF/VCR</i> switch to <i>CAMERA</i> or <i>VCR</i>.• If using battery, it might need to be recharged.• If using AC adapter/charger, make sure it is plugged into a working outlet.
Won't record or play back	<ul style="list-style-type: none">• If using AC adapter/charger, make sure it is plugged into a working outlet.• Make sure <i>CAMERA/OFF/VCR</i> switch is set to correct position for desired operation.• There might not be a cassette in the camcorder.• Try ejecting and reinserting the cassette.• The cassette tape might be broken, try another cassette.• You may have reached the end of the cassette, try rewinding it.• Moisture condensation might cause the tape to stick to the headwheel and damage the headwheel or tape. Give the camcorder 2 or 3 hours to reach a stable temperature before reinserting a cassette.
Won't play back	<ul style="list-style-type: none">• Set <i>CAMERA/OFF/VCR</i> switch to <i>VCR</i> position.
Won't record	<ul style="list-style-type: none">• Safety tab is removed. <i>See page 16.</i>• Set <i>CAMERA/OFF/VCR</i> switch to <i>CAMERA</i>.
No picture	<ul style="list-style-type: none">• Remove lens cap.
Camcorder turns off	<ul style="list-style-type: none">• Set <i>CAMERA/OFF/VCR</i> switch to <i>OFF</i> and then <i>CAMERA</i> or <i>VCR</i> to turn back on. If camcorder is left in record-pause or play-pause for several minutes, it turns off to prevent tape wear.

Trouble Checks

Trouble	Checks and Adjustments
Sound is too low or distorted	<ul style="list-style-type: none"> • Subject was too far from camcorder.
Tape stops during rewind or fast forward or rewind or fast forward not operating	<ul style="list-style-type: none"> • Tape-counter displayed. Whenever the tape counter appears, the camcorder stops rewinding (or fast forwarding) when the counter reads <i>0000M</i>. Press <i>REW/REVIEW</i> or <i>FFWD</i> again to continue rewinding or fast forwarding or press <i>DISPLAY</i> to remove the tape counter from the viewfinder. • Make sure titler graphics do not appear in viewfinder. Press <i>TITLER</i> button to remove.
Camcorder remains in play-pause mode	<ul style="list-style-type: none"> • Press <i>REC/PAUSE</i> to return to normal playback.
Poor auto-focus operation	<ul style="list-style-type: none"> • Lens is smudged and image appears unfocused. • Eyepiece focus control is misadjusted.
Viewfinder displays are out of focus or dark	<ul style="list-style-type: none"> • Eyepiece focus control is misadjusted. Adjust for your vision. <i>See page 20.</i> • Rotate the small <i>BRIGHT</i> dial on the bottom of the viewfinder to control the brightness of the image in the viewfinder.
Picture quality is poor during playback	<ul style="list-style-type: none"> • Tape was recorded on a different camcorder or VCR. If the picture contains black-and-white streaks, press one <i>TRACKING</i> button to correct it. <i>See page 35.</i> • Camcorder only has one speed (SP). If the tape was recorded at a different speed, it cannot be played back on this camcorder.
Date and/or time or title were recorded on tape	<ul style="list-style-type: none"> • Displays are recorded on tape whenever they appear in the viewfinder. Remove them from the viewfinder when recording. <i>See page 19.</i> • When  <i>AUTO</i> or  <i>TITLE</i> is selected, the display is automatically recorded when you begin recording or change the cassette. <i>See page 19.</i>

Trouble Checks

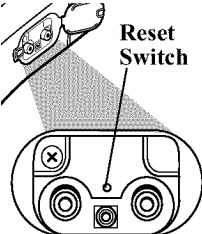
Trouble	Checks and Adjustments
Title is recorded on tape	<ul style="list-style-type: none"> Title is recorded whenever it appears in the viewfinder. Press the <i>TITLER</i> button to remove the title from the viewfinder. <i>See page 32.</i>
Date and/or time are incorrect	<ul style="list-style-type: none"> Date or time might need to be set. <i>See page 18.</i> Clock lithium cell battery might need recharging. <i>See page 19.</i>
Bright, crystal-shaped spots appear in viewfinder	<ul style="list-style-type: none"> Sunlight is directly entering the lens.
Colored bright spots appear in viewfinder	<ul style="list-style-type: none"> Black spots or bright spots of light (red, green, or blue) might appear in viewfinder. These spots are not recorded on the tape and are not due to a defect in the unit.
Rechargeable battery runs down sooner than expected	<ul style="list-style-type: none"> Lead-acid batteries must be kept charged. Charge your battery before and after every use and at least every six months. Battery run times are measured when the camcorder is recording continuously. To check your battery; charge it completely, aim the camcorder at a clock, and record the clock. When the camcorder stops recording, play the last part of the tape and check the time on the clock. A one-hour battery should give you about 60 minutes of recording time. In practical use, a fully charged battery might not record for 60 minutes because the battery uses power when you pause the recording and uses extra power when you zoom.
Camcorder does not turn on and/or function buttons will not operate	<p>Remove the power source. After one minute press the reset switch gently using a nonmetallic pointed item, such as a toothpick, until you feel a click. This resets the camcorder to the factory settings and erases the date, time, and custom settings. Wait for at least one minute after resetting the camcorder to attach a power supply.</p>  <p>The diagram shows a close-up of the camcorder's control panel. A label 'Reset Switch' points to a small, rectangular button located between two circular buttons. A line also points to the top of the camcorder, indicating the location of the reset switch on the device's exterior.</p>

Care and Maintenance

Clean the Camcorder

To clean the camcorder's exterior, remove any power source connected to the camcorder and gently wipe it with a clean soft cloth.

Caution: Use of strong cleaning products, such as those containing alcohol or benzine, might damage the camcorder.

Clean the Camcorder's Lens

To clean the camcorder's lens, blow it with a blower brush, and gently wipe the lens with cleaning tissue and commercially prepared cleaning solution designed for use on camera lens. Improper cleaning may scratch the lens.

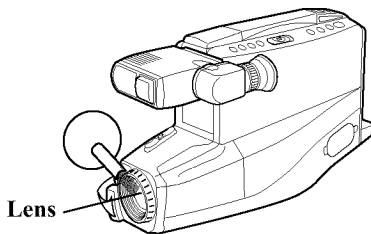

Caution: Do not touch the lens with your fingers. The oil from your skin can damage the lens.

Clean the Camcorder's Viewfinder

You can remove the viewfinder eyepiece for cleaning.

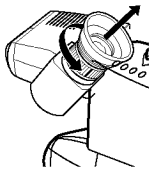

1. Turn the eyepiece counterclockwise and pull it out.

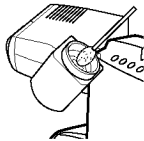

2. Gently use a cotton swab or blower brush to remove the dust.

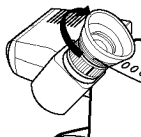

3. To reattach the eyepiece, align the reference marks and turn the eyepiece clockwise until it clicks into place.

Care and Maintenance

Proper Care and Storage

- Keep dust and grit from entering the camcorder's cassette door. Dust and grit are abrasive and cause excessive wear to both the camcorder's recording/playback heads and cassettes.
- Always place the lens cap back on the camcorder when it is not in use.
- Before handling your camcorder, make sure your hands and face are free from any chemical products such as suntan lotion, as it might damage the finish.
- The camcorder might be damaged by improper storage or handling. Do not subject the camcorder to swinging, shaking, or dropping.
- Do not store the camcorder in temperatures below -22°F (-30°C) or above 149°F (65°C).
- When the camcorder is not in use, always remove the cassette and AC adapter/charger or battery.
- Retain the original carton for future storage or shipping purposes.

Things to Avoid

- Do not attempt to disassemble your camcorder. There are no user-serviceable parts inside.
- Avoid operating your camcorder immediately after moving it from a cold location to a warm location. Give the camcorder 2 to 3 hours to reach a stable temperature before inserting a cassette. When the camcorder is moved from cold to warm, condensation might cause the tape to stick to the headwheel and damage the headwheel or tape.
- Do not aim your camcorder at the sun or other bright objects.
- Do not leave your camcorder in direct sunlight for extended periods of time. The resulting heat buildup might permanently damage the camcorder's internal parts.
- Do not operate the camcorder in extremely humid environments.
- Do not carry the camcorder by the viewfinder. This might cause personal injury or damage the camcorder.
- Do not operate the camcorder near the ocean as salt water or salt water spray may damage the internal parts of the camcorder.
- Do not operate the camcorder for extended periods in temperatures below 40°F (4°C) or above 95°F (35°C).
- Do not expose the camcorder or adapter/charger to rain or moisture. If any component becomes wet, turn off the power and take the unit to an Authorized RCA Camcorder Service Center.
- Do not use an adapter/charger or batteries other than the ones specified for the camcorder. Use of the wrong accessories might cause damage to the camcorder.

Specifications

General

Power requirement: 9.6VDC
Power consumption: 7.5 watts
Weight: 4.4 lbs. (2kg)

Dimensions – Including Viewfinder:

4-1/4" (W) x 8-3/8" (H) x 13-1/8" (D)
108 (W) x 213 (H) x 334 (D) mm

Video Recorder Section

Format: VHS
Record/playback system:
Two video record/playback heads
Video signal: EIA standard
NTSC color

Viewfinder

Color viewfinder

Camera Section

Scanning: 525 lines/60 fields/30 frames
Image Sensor: 1/4" CCD Imager
Lens: F1.4
16:1 (4-64 mm) power zoom lens
Diameter: 46 mm

AC Adapter/Charger

Power requirement: 120 V,
50/60 Hz.
Power consumption: 24 watts
Weight: .85 lbs. (390g)
Dimensions:
6"(W) x 1.7"(H) x 2.7"(D)
152 (W) x 43 (H) x 69 (D) mm

Tripod Mount

One 1/4" x 10 threaded hole

Information to User

This equipment has been tested and found to comply with the limits for a Class B digital device pursuant to Part 15 of the FCC Rules. These limits are designed to provide reasonable protection against harmful interference in a residential installation. This equipment generates, uses, and can radiate radio frequency energy and, if not installed and used in accordance with the instructions, may cause harmful interference to radio communications. However, there is no guarantee that interference will not occur in a particular installation. If this equipment does cause harmful interference to radio or television reception, which can be determined by turning the equipment off and on, the user is encouraged to try to correct the interference by one or more of the following measures:

- Reorient or relocate the receiving antenna.

- Increase the separation between the equipment and receiver.
- Connect the equipment into an outlet on a circuit different from that to which the receiver is connected.
- Consult the dealer or an experienced radio/TV technician for help.

Alterations or modifications carried out without appropriate authorization may invalidate the user's FCC right to operate the equipment.

This Class B digital apparatus meets all requirements of the Canadian Interference — Causing Equipment Regulations.

Cet appareil numérique de la classe B respecte toutes les exigences du Règlement sur le matériel brouilleur du Canada.

Customer Assistance and Service

You can reach Thomson at the following number:

800-283-6503

(Toll free inside U.S.A.)

Our toll-free Camcorder number operates from 8 a.m. to 5 p.m., CST Monday – Friday for U.S. customers only

Thomson provides a toll-free telephone number to help you with any problems you may encounter with your camcorder. Many can be diagnosed over the phone, and if necessary, repair or replacement will be arranged. Please have your camcorder model/serial number and date of purchase ready when you call. If your unit is out of warranty, we will quote the cost of a repair or replacement unit to you.

Returning equipment to Thomson for repair or exchange

If we are unable to resolve your problem over the phone, we will gladly service your unit or exchange it for a new or, at our option, refurbished camcorder. Refer to the limited warranty on the next page to learn about your specific rights and responsibilities.

Always consult Thomson and get a Return Authorization number before returning anything! Obtain a Return Authorization (RA) number from the telephone representative before returning your equipment to avoid delays, accounting errors, or even loss of your unit.

Important information to customers who ship defective equipment to Thomson Consumer Electronics

The Thomson representative who authorized the return of your equipment will give you an RA number over the phone. They will also provide you with instructions on where and how to return your Camcorder. Write the number in large, clear characters on the outside of the box. To avoid confusion and misunderstandings, shipments without an RA number clearly visible on the outside of the box will be returned to you at your expense.

Include a brief note describing the problem and any conversations about the problem you have had with Thomson personnel.

Include your name, address and model/serial number of your Camcorder. These numbers

are located on the bottom of your unit.

If your Camcorder is within the warranty period, please provide a copy of the bill of sale to verify purchase date. Use the original box and packing material to protect the equipment from damage in shipment.

For your protection, insure all shipments for full replacement value and use a reliable shipper. Thomson assumes no responsibility for warranty shipments from the customer to the factory if not shipped in the manner prescribed by Thomson.

Limited Warranty

What your warranty covers:

- Any defect in materials or workmanship.

For how long after your purchase:

- 90 days for labor charges.
- One year for parts.

The warranty period for rental units begins with the first rental or 45 days from date of shipment to the rental firm, whichever comes first.

What we will do:

During the initial 90 days

- Exchange your camcorder with a new or refurbished unit, or repair your camcorder. The option will be ours. There will be no cost to you.

After the 90 days and within one year

- Exchange your camcorder with a new or refurbished unit, or repair your camcorder. The option will be ours. Parts will be provided at no charge, but you will be responsible for the cost of labor required for the repair.

How you get service:

- Call 1-800-283-6503 and have your unit's date of purchase and model/serial number ready. The model/serial number information is on the bottom of your camcorder.
- A representative will troubleshoot your problem over the phone. If the representative determines that you should receive a replacement unit, you will be provided with a Return Authorization (RA) number and the location of a nearby exchange point if one exists. No returns will be accepted without the RA number.

To receive a replacement Camcorder before you return yours:

Option 1

1. Provide your Discover, MasterCard, or Visa account number and expiration date

to our phone representative. This is for security purposes. If we receive your unit, excluding all accessories, within 14 days from the date you were provided the RA number, only items not covered by warranty will be charged to your account. **IF YOUR UNIT IS NOT RECEIVED WITHIN 14 DAYS, THE SUGGESTED RETAIL VALUE OF THE CAMCORDER WILL BE CHARGED TO YOUR CREDIT CARD.** This amount will be credited if the unit is subsequently received.

2. We will send you a replacement unit.
3. Ship the unit back to us, excluding all accessories, using the replacement unit's carton. Shipping instructions will be included in the carton along with your RA number which will allow you to easily ship the unit back to us. **Make sure you insure your shipment in case of damage or loss.** Include with the shipment:
 - Evidence of purchase date, such as a bill of sale, to verify your unit's warranty eligibility.
 - A brief note describing your camcorder's problem.
 - Your name, address and phone number.

Return transportation, storage, handling, and insurance costs are your sole responsibility. We accept no liability in case of damage or loss.

Option 2

1. We will send a replacement unit to the exchange point.
2. The exchange location will notify you of its arrival.
3. Take your unit, excluding all accessories, and your evidence of purchase date (such as a bill of sale) to the exchange location and you will be provided the new or refurbished unit.
4. If the repairs were covered by your warranty, you will not be billed.

(Continued on the next page)

Limited Warranty

To receive a replacement unit after we have received your unit:

1. **Write the RA number on the outside of the carton used to return the unit. Make sure you insure your shipment in case of damage or loss.**
2. Carefully pack the unit, excluding all accessories, using the original box and packing material if possible.
3. Include with the shipment:
 - Evidence of purchase date, such as a bill of sale, to verify your unit's warranty eligibility.
 - A brief note describing your camcorder problem.
 - Your name, address and phone number.

Return transportation, storage, handling, and insurance costs are your responsibility. We accept no liability in case of damage or loss.

4. The representative will advise the address to mail a cashier's check or money order for payment if there are any out of warranty labor or parts charges and you elect not to use your credit card.
5. Upon receipt of your product, a new or refurbished unit will be shipped to you next business day delivery in the continental U.S.A.

To have your Camcorder repaired by an Authorized RCA Camcorder Service Center:

- Check with your dealer or call 1-800-336-1900 for the Authorized RCA Camcorder Service Center nearest you.
- Take your unit to the Authorized RCA Camcorder Service Center of your choice.
- Show the Authorized RCA Camcorder Service Center representative evidence of purchase date, such as a bill of sale.
- Pick up your camcorder when repairs are complete.

What your warranty does not cover:

- Adjustment of customer controls.
- Damage from misuse or neglect.
- A unit that has been modified or incorporated into other products or is used for institutional or other commercial purposes.
- Batteries for remote control and clock.
- Cleaning of video/audio heads.
- Camcorders purchased or serviced outside the U.S.A.
- Return transportation, storage and handling costs of your unit, including insurance for loss or damage.
- Acts of God, such as but not limited to lightning damage.

Product Registration:

- Please complete and mail the Product Registration Card packed with your camcorder. It will make it easier to contact you should it ever be necessary. The return of the card is not required for warranty coverage.

How State Law relates to warranty:

- This warranty gives you specific legal rights and you also may have other rights that vary from state to state.

If you purchased your camcorder outside the United States:

- This warranty does not apply. Contact your dealer for warranty information.

A

- Accessories
 - included 3
 - optional 41
 - order form 45
- Adapter/charger
 - accessory 3
 - charging battery 11
 - using 4, 10
- AE focus indicators 22, 25
- Assistance 3
- AUDIO and VIDEO jacks 8, 38
- Auto focus 25
- Auto Shot feature 25

B

- Battery 3
 - attaching and removing 12
 - care 14
 - charging 11
 - level indicator 13, 22
 - safety precautions 14
 - storage 14
 - using 11
- BATTERY EJECT button 9, 12
- BRIGHT control 6, 8, 21, 33

C

- Cable TV installer note 39
- Camcorder
 - clean 51
 - operating controls 8
 - turn on 5
- CAMERA/OFF/VCR switch
 - 5, 8, 12, 13, 15, 18, 19, 24, 25,
 - 28, 30, 31, 32, 33, 34, 37, 39

- Car cord adapter 15
- Care and maintenance
 - clean the camcorder viewfinder 51
 - clean the lens 51
 - clean the viewfinder 51
 - proper care and storage 52
 - things to avoid 52
- Care and storage
 - camcorder 52
 - cassette 17
- Cassette compartment 5
- Cassette door 9
- Cassette holder 17
- Cassettes
 - inserting/removing 17
- Cassettes, video 16
- Chart of characters in titler 31
- Checks, trouble 48
- Clean the camcorder lens 51
- Clean the viewfinder 51
- Clock battery
 - charging 19
- Copy tapes 37
- Customer Assistance 54

D

- Date and time
 - display 18, 23
 - recording 19
 - setting 18
- DATE/TIME button 8, 18, 23, 32
- DC cable 3, 10, 12, 15
- DC IN 9.6V jack 9, 15
- Digital effects indicators 22
- DISPLAY button 8, 13, 22, 26, 37
- Displays in viewfinder 22, 23

E

EDIT-ADV button 8, 30
Electronic indexing 26
Erase protection 16
Eyepiece focus control 9, 20, 33

F

F FWD (fast forward) button
8, 18, 25, 28, 30, 34
Fade indicators 22
First time operation 3

H

Handstrap 9
Head cleaning 16

I

INDEX indicator 22, 26
Indicators
AE focus 22, 25
battery level 13, 22
digital effects 22
fade 22
fast-forwarding 22
INDEX 22, 26
NO TAPE 23
pause 22
REC 6, 22
record-pause 6
rewind 22
status 22
tape counter 23, 28
TAPE END 23
time remaining 23, 26
zoom level 23, 27
Instant zooming 27

L

Lens 8
Lens cap 4
Lens hood 8
removing 44

M

Macro focus 25
Memory-stop feature 28
Microphone 8, 24

N

NO TAPE indicator 23

O

Operating controls 8
Optional accessories 41
Order form
accessories 45

P

PLAY button 7, 25, 33, 37, 39
Playback 7
on TV or VCR with A/V inputs 36
on TV without A/V inputs 38
Playback features
stop-action pause 34
tape counter 28
tape positioning 34
tracking 35
visual searching 34
Playback speed 16

- Powering your camcorder
 - using adapter/charger 10
 - using battery 11
 - using optional car cord adapter 15
- Problem solving 48

Q

- Quick review feature 24

R

- REC indicator 6, 22
- REC/PAUSE button
 - 6, 9, 32, 34, 37, 39
- Recording
 - speed 16
 - tips 29
- RESET button 28
- Reset switch 8
- REW/REVIEW button
 - 7, 8, 18, 24, 25, 28, 30, 34
- Rewinding indicator 22
- RF DC jack 8
- RF DC OUT jack 38
- RF output adapter 38

S

- Safety precautions
 - battery 14
- Safety tab 16
- Searching during playback 34
- Shoulder strap 3
- Shoulder strap attachment rings 9
- Shoulder strap attachment ringsing 40
- Solving problems 48
- SP speed 16, 33
- Specifications 53

- Speed
 - recording and playback 16
- Status indicators 22
- STOP button 7, 28
- Stop-action pause 34
- STOP/EJECT button
 - 5, 8, 13, 17, 18, 28,
 - 30, 33, 34, 37, 39

T

- Tape
 - inserting 5
- Tape copying 37
- Tape counter 23, 28
- TAPE END Indicator 23
- TAPE indicator 23
- Tape positioning 34
- Tape warnings 23
- Time and date
 - display 18, 23
 - recording 19
 - setting 18
- Time remaining display 26
- Time remaining indicator 23
- Tips
 - recording 29
- Title Select buttons 8
- Titler 30
 - chart of characters 31
 - correct an error 31
 - create a title 31
 - record on a tape in camcorder 32
 - record while copying a tape 32
- TITLER button 8, 30
- Titles
 - recording 19
- Tracking 35
- TRACKING buttons 9, 35
- Tripod 42
- Trouble checks 48

V

VIDEO and AUDIO jacks 8, 38

Videocassettes 16

Viewfinder 9

adjust for viewing 20

displays 22

eyepiece focus control 20

playback 33

Visual searching 34

W

Warnings 23

Warranty 55

Z

Zoom buttons 9, 24, 27

Zoom level indicators 23, 27

Note: This equipment has been type tested and found to comply with the limits for a Class B Digital Device in accordance with the specifications in Part 15 of FCC Rules. These rules are designed to provide reasonable protection against radio and television interference in a residential installation. This equipment generates, uses and can radiate radio frequency energy and, if not installed and used in accordance with the instructions, may cause harmful interference to radio communications. However, there is no guarantee that interference will not occur in a particular installation.

If this equipment does cause interference to radio or television reception (which you can determine by turning the equipment off and on), try to correct the interference by one or more of the following measures.

- Reorient or relocate the receiving antenna (that is, the antenna for radio or television that is “receiving” the interference).
- Change the position of the camcorder with respect to the radio or television equipment that is receiving interference.
- Move the camcorder away from equipment receiving interference.
- Plug the adapter/charger into a different wall outlet so the receiver and equipment receiving interference are on different branch circuits.

If these measures do not eliminate interference, please consult your dealer or an experienced radio/television technician for additional suggestions. Also, the Federal Communications Commission has prepared a helpful booklet, “How To Identify and Resolve Radio/TV Interference Problems”. This booklet is available from the U.S. Government Printing Office, Washington, D.C., 20402. Please specify stock number 004-000-00345-4 when ordering copies.

 **THOMSON CONSUMER ELECTRONICS**

**10330 N Meridian Street
Indianapolis, IN 46290**

©1999 Thomson Consumer Electronics, Inc.

Trademark(s)[®] Registered

Marca(s) Registrada(s)

Printed in Japan

TOCOM 15407930

QR31044