

Important Safety Information

Be sure to read all the safety information before you begin to use this product.

WARNING: To reduce the risk of fire or shock hazard, do not expose camcorder or AC adapter/charger to rain or moisture.

CAUTION

RISK OF ELECTRIC SHOCK
DO NOT OPEN



This symbol indicates “dangerous voltage” inside the product that presents a risk of electric shock or personal injury.

ATTENTION

RISQUE DE CHOC ELECTRIQUE
NE PAS OUVRIR

This symbol indicates important instructions accompanying the product.

TO REDUCE THE RISK OF ELECTRIC SHOCK, DO NOT REMOVE THE COVER (OR BACK). NO USER-SERVICEABLE PARTS ARE INSIDE. REFER SERVICING TO QUALIFIED SERVICE PERSONNEL.

Cautions

CAUTION: To prevent electric shock, match wide blade of plug to wide slot, fully insert.

ATTENTION: Pour éviter les chocs électriques, introduire la lame la plus large de la fiche dans la borne correspondante de la prise et pousser jusqu'au fond.

To reduce risk of injury, charge only rechargeable batteries recommended by the manufacturer for this camcorder. Other types of batteries may burst causing damage and personal injury.

FCC Regulations state that unauthorized changes or modifications to this equipment may void the user's authority to operate it.

Product Registration

Please fill out the product registration card and return it immediately. Returning this card allows us to contact you if needed.

Keep your sales receipt for proof of purchase to obtain warranty parts and service and attach it here. Record the serial number and model numbers located on the bottom of the camcorder.

Model No: CC4352

Serial No: _____

Purchase Date: _____

Purchased From: _____

Assistance

We want to make sure you enjoy your new camcorder. If you have any questions, call:

Camcorder Exchange Warranty	800-283-6503 (<i>pages 74-75</i>)
Customer Service	800-336-1900 (<i>page 73</i>)
Accessories	800-338-0376 (<i>pages 59-62</i>)

Table of Contents

Safety Information	ii	Cassette Care and Storage	19
First Time Operation	3	Setting the Time and Date	20
Assistance	3	To Correct the Date or Time	20
Unpacking the Camcorder and		Charging the Built-in	
Accessories	3	Clock Battery	21
Adapter/Charger	12	LCD Monitor or Viewfinder	
Attaching	12	Displays	21
Removing	12	Recording Time and Date	21
Powering Your Camcorder ..	12	AUTO Date	21
Using the Battery	13	Auto TITLE	21
Charging	13	Date	21
Attaching	14	Selecting Display	21
Removing	14	Recording	22
Battery Level Indicator	15	Using the LCD Monitor	22
Battery Care	16	Using the Viewfinder	23
Battery Storage	16	Eyepiece Focus Control	23
Battery Safety Precautions...	16	Adjusting the Viewfinder	23
Care and Storage	16	LCD Monitor or Viewfinder	
Safety Precautions	16	Displays	24
Car Cord Adapter	17	AE:60 (Auto Exposure)	
Using Videocassettes	18	Shutter Speed	24
Erase Protection – Safety Tab	18	Battery Level Indicator	24
Recording and Playback Speed		Digital Effects (ZM:2)	24
and Times	18	Fade Indicator	24
Insert and Remove Cassettes	19	INDEX Indicator	25
		Status Displays	25

Table of Contents

Tape Counter with Memory Stop	25
Tape Warnings (TAPE, NO TAPE, and TAPE END)	25
Time and Date Display	25
Tape-Remaining Indicator	25
Zoom Indicators	25
DISPLAY Button	26
Microphone	26
Quick Review Feature	26
Auto Shot Feature	27
Auto Focus	27
Macro Focus	27
Tape-Remaining Display	27
Electronic Indexing	28
Zooming	29
Using the Zoom Buttons	29
Zoom Level Indicator in LCD Monitor or Viewfinder	29
Using the Instant Zoom Button (INST. ZOOM)	29
Instant Zoom Display in LCD Monitor or Viewfinder	29
I. ZOOM	29
Digital Effects	30
Selecting a Digital Effect	30
LCD Monitor or Viewfinder Displays	30
16X9 Mode	31
16X9 Display in LCD Monitor or Viewfinder	31
Negative Mode	32
Digital Zooming	32
Mosaic Mode	33
Mirror Mode	33
Fading In and Out of Scenes	34
Selecting a Type of Fade	34
Fade In	35
Fade Out	35

Tape Counter	36
Using the Memory-Stop Feature ...	36
Camera Edit Feature	37
Creating a Title	39
Correcting an Error	39
Chart of Characters	39
Recording a Title	40
Recording Tips	41
Travel Tips	41
To Play Back a Tape	43
Playback Features	44
Tape Positioning	44
Visual Searching	44
Stop-Action Pause	44
Playback on a TV/VCR with A/V jacks	46
Playback Operation	47
Copying Tapes on Your VCR	47
Viewing What the Camcorder is Seeing	47
Playback Operation	49
Normal TV Viewing	49
Troubleshooting	58
Cleaning the Camcorder	62
Cleaning the Lens	62
Clean the LCD Monitor	62
Cleaning the Viewfinder	62
Proper Care and Storage	63
Things to Avoid	63
Specifications	64
Customer Assistance and Service ...	65
Warranty Information	66
Product Registration	67
Index	68

First-Time Operation

This section describes the basic steps necessary to set up your camcorder to record. Refer to the other sections for detailed operation and feature options.

Assistance

The toll-free numbers are available to help you with any problem you may encounter.

Camcorder Exchange Warranty.....800-283-6503
Customer Service..... 800-336-1900
Accessories..... 800-338-0376

1. Unpacking the Camcorder and Accessories.

- Save the packing materials and box in case you ever need to ship or store your camcorder.
- The items shown below are packed with your camcorder. If any are missing or appear damaged, contact your dealer immediately.

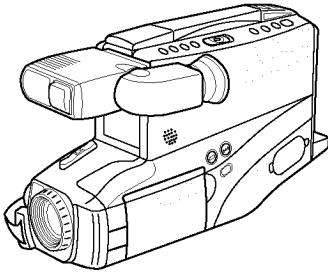

Model CC4352

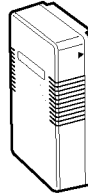

WARNING:
LEAD-ACID
BATTERY.
MUST BE
DISPOSED OF
PROPERLY.

Rechargeable 10-Volt Battery
Stock No. EP096FS

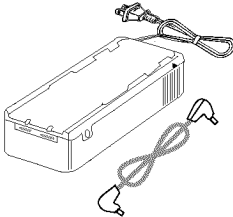

AC Adapter/Charger: Stock No. 241044
DC Cable: Stock No. 233328



Shoulder Strap
Stock No. 227327 or
Stock No. 241305

Caution: Do not use this adapter/charger for any purpose other than charging the EP096FS or EP096FL battery pack or supplying power to the camcorder.

(continued on next page)

First-Time Operation

2. Attaching the Adapter and Charger.

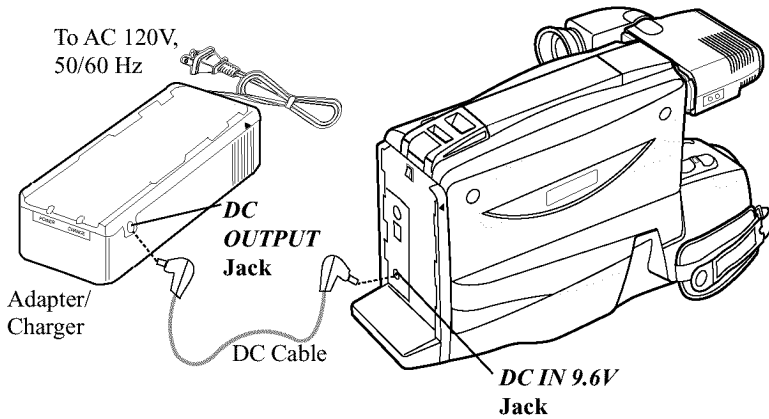

Since the battery must be charged before it can be used the first time, attach the adapter/charger to the camcorder.

1. Attach one end of the adapter/charger's DC cable to the *DC OUTPUT* jack on the side of the adapter/charger.
2. Attach the other end of the cable to the *DC IN 9.6V* jack on the camcorder.
3. Plug the adapter/charger's plug into an operating outlet.
4. *Details are on page 12.*

3. Adjusting the Handstrap, Removing the Lens Cap, and Attaching it to the Camcorder.

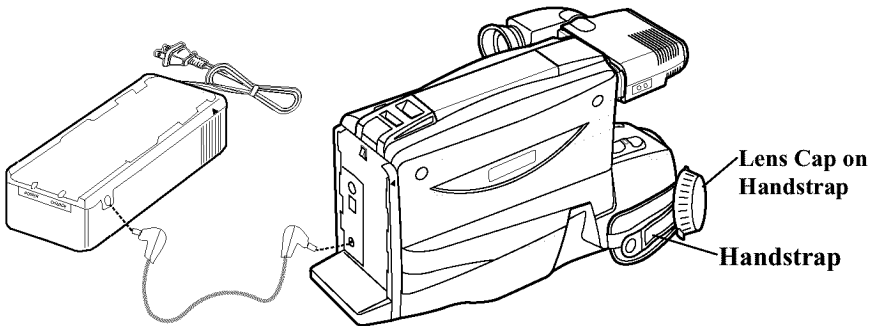

1. Open the handstrap, insert your hand, and adjust the handstrap to fit your hand.
2. Remove the lens cap and attach it to the handstrap *as shown*.

First-Time Operation

4. Inserting a Tape.

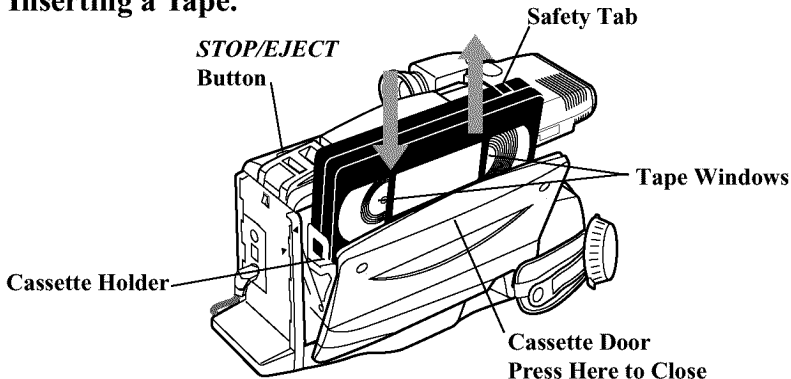

1. Press *STOP/EJECT* to open the cassette compartment.
2. Insert the cassette with the safety tab facing up and the tape windows facing out.
3. Press the cassette down gently until it locks into place, and close the cassette compartment door.
4. *Details are on page 19.*

5. Turning on the Camcorder.

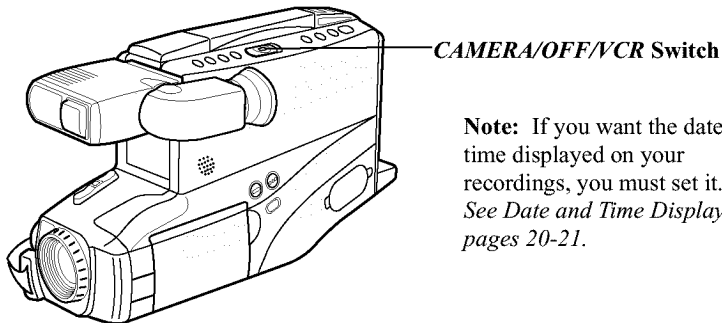

- Press and hold the small button on the *CAMERA/OFF/VCR* switch while you slide it to *CAMERA*. The camcorder enters record-pause.
- The position of this switch tells the camcorder whether you want to record (*CAMERA*), turn the

Note: If you want the date and time displayed on your recordings, you must set it. See *Date and Time Display* on pages 20-21.

- power off (*OFF*), or play back tapes (*VCR*).
- The camcorder automatically turns off if it remains in record-pause for five minutes. Place the switch to *OFF* and then back to *CAMERA*.

(continued on next page)

First-Time Operation

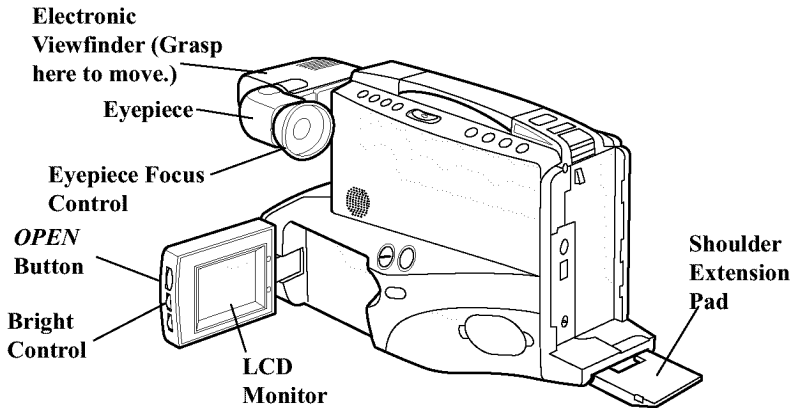

6. Use the LCD Monitor or Viewfinder to See What's Recording.

You can watch what you're recording on the LCD monitor or in the black-and-white viewfinder. When you open the LCD monitor more than 45°, the viewfinder automatically turns off. When you close the LCD monitor, the viewfinder automatically turns on. When you extend the LCD monitor 90° and rotate it all the way around (screen side facing toward the person you're recording), both the viewfinder and the LCD monitor show what's being recorded.

Use the LCD Monitor

1. Unfold the shoulder extension pad.
2. Press the *OPEN* button to open the LCD monitor. Make sure the monitor is open at least 45°. The viewfinder automatically turns off.
3. Rotate the monitor around only when it is open 90°. When you rotate the monitor 90° or more, the image becomes a mirror image and the viewfinder turns on.
4. To adjust the brightness of the image in the monitor, turn the bright control.
5. Fit the shoulder extension pad to your shoulder for convenient viewing using the LCD monitor.

Use the Viewfinder

1. Make sure the monitor is closed and locked. If the monitor is open more than 45°, the viewfinder automatically turns off.
2. Grasp the viewfinder and rotate it horizontally.
3. Pull the viewfinder out from the camcorder and rotate the eyepiece into a comfortable viewing position.

Caution: Pulling on the eyepiece might cause damage to the eyepiece or camcorder.

4. Turn the eyepiece focus control to adjust the focus of the viewfinder for your vision.

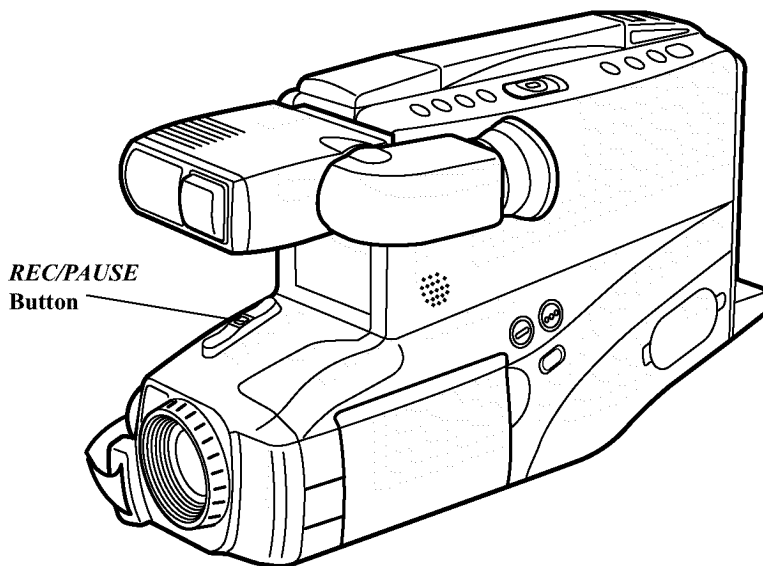

7. Start and stop recording.

- Press and release the *REC/PAUSE* button to start recording. *REC* appears in the viewfinder or on the LCD monitor, when the camcorder is recording.
- Press and release the *REC/PAUSE* button again to stop recording. The camcorder is now in the record-pause mode (**||** appears in the viewfinder or on the LCD monitor when the camcorder is in record-pause).

(continued on next page)

First-Time Operation

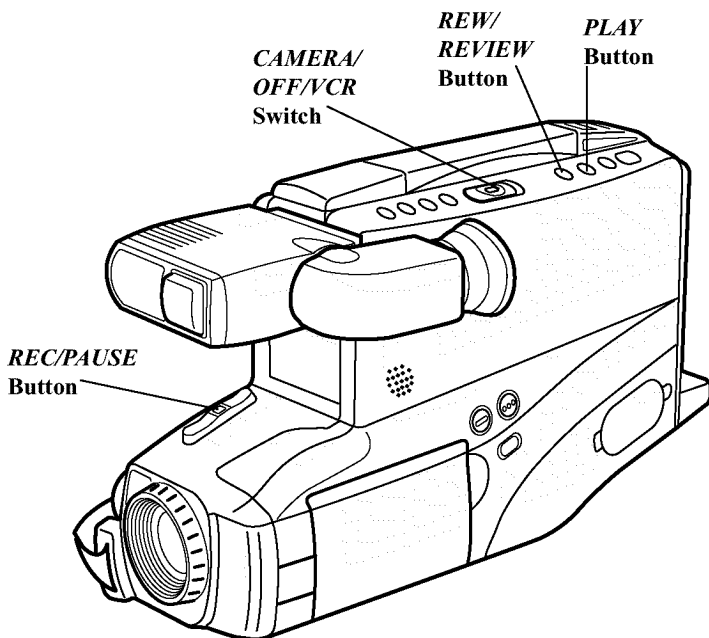

8. Play back what you have recorded.

1. Press the *REC/PAUSE* button to pause recording.
2. Press and hold the small button on the *CAMERA/OFF/VCR* switch while you slide it to *VCR*.
3. Press *REW/REVIEW* to rewind the tape.
4. Press *PLAY* to play back the tape.
5. Press *STOP/EJECT* when you are finished playing back the tape.

Details on LCD monitor and viewfinder playback are on pages 42-43.

9. Set the *CAMERA/OFF/VCR* switch to *OFF* to turn off the camcorder.

10. Close the LCD monitor and replace the lens cap.

Caution: Make sure the LCD monitor is open 90° before rotating it back into position for closing.

First-Time Operation

11. Review camcorder's operating controls.

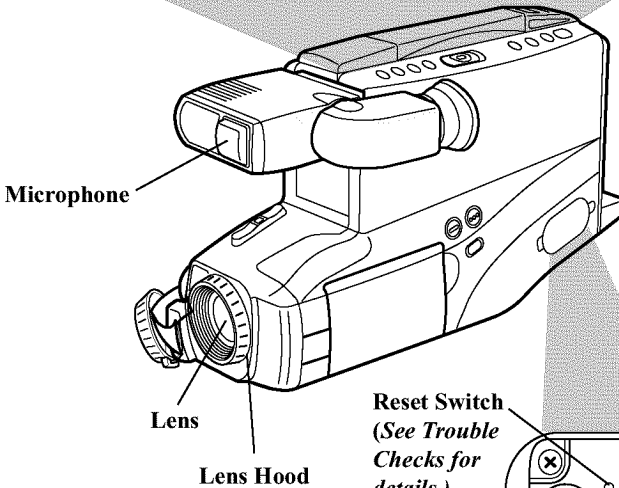
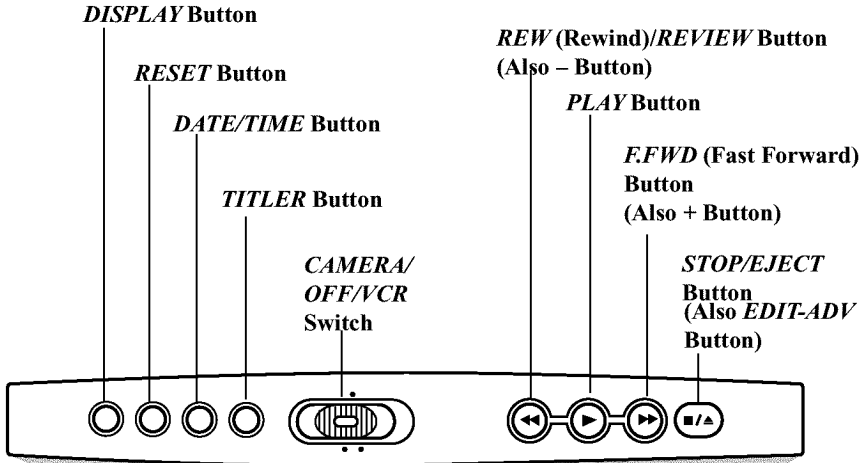

Reset Switch
(See *Trouble Checks* for details.)

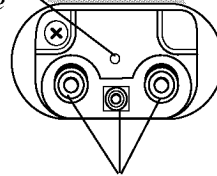

VIDEO, AUDIO OUT, and RF DC OUT Jacks
(Located Behind Small Cover)

(continued on next page)

First-Time Operation

11. Review camcorder's operating controls. (continued)

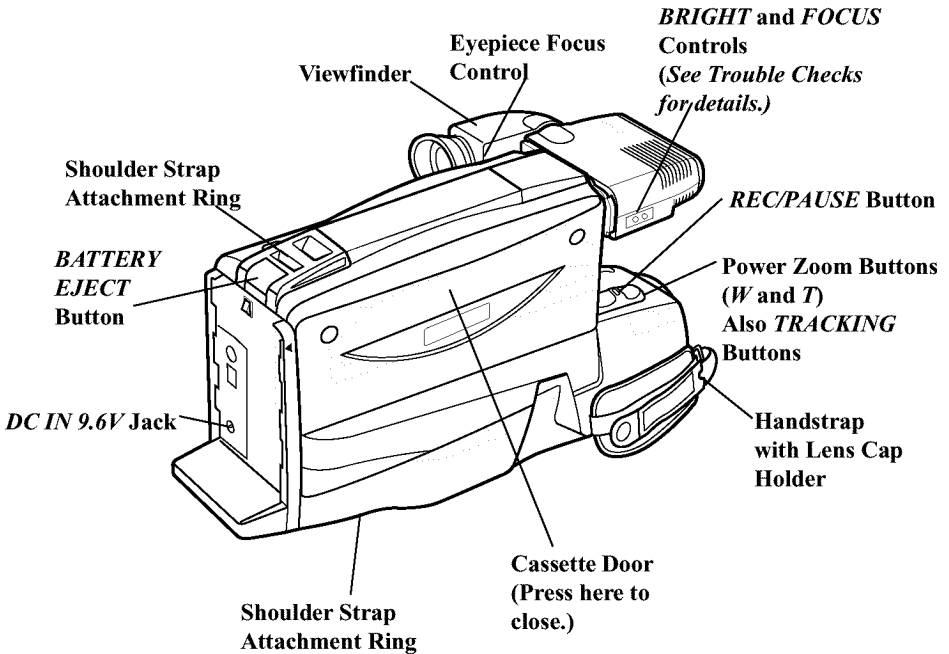
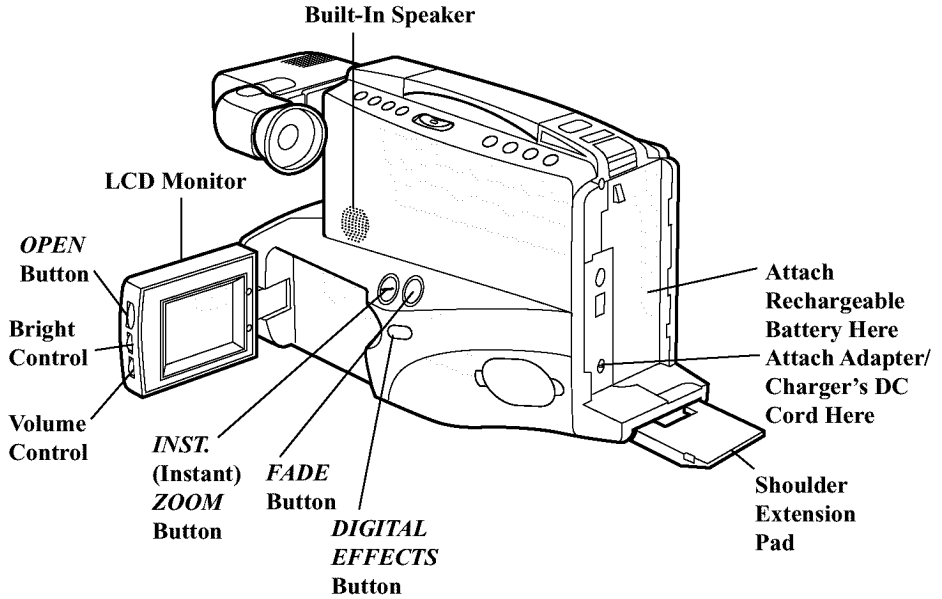

Included Accessories

Attaching the Shoulder Strap

The camcorder's shoulder strap is designed to let you carry the camcorder from your shoulder and – when you are ready to shoot – bring the camcorder to shooting position in one quick movement.

To Attach the Shoulder Strap

1. Unfasten one end of the shoulder strap from the buckle. Make sure you leave the buckle on the strap.

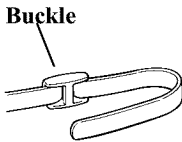

2. Thread one end of the shoulder strap through one of the shoulder strap rings as shown below.

Shoulder Strap Attachment Ring

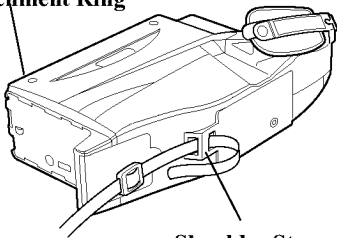

Shoulder Strap Attachment Ring

3. Thread the end of the strap back through the buckle making sure it is threaded over the outer strap. Make sure the strap is not twisted.

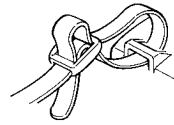

4. Repeat steps 1-3 to attach the other end of the strap.
5. Pull on the straps and make sure they are securely fastened before using the shoulder strap to support your camcorder.

Cautions: When carrying the camcorder with the shoulder strap, rotate the viewfinder up to its original position. If the monitor is open, close and lock it. This helps prevent possible damage to the viewfinder or monitor from bumping against your body as you move.

Make sure the shoulder strap is firmly attached before using it to carry the camcorder.

Power Your Camcorder

Use the Adapter/Charger to Power Your Camcorder

The adapter/charger attaches to the camcorder and lets you power your camcorder directly from standard household power. The adapter/charger operates on 120 volts, 50/60 Hz, and can be used to power the camcorder or recharge the battery.

Caution: Do not attempt to use a “power converter” to use your AC adapter/charger on a power source other than 120 volts, 50/60 Hz, or the adapter/charger and camcorder may be damaged. If you wish to operate the AC adapter/charger on a power source other than 120 volts, 50/60 Hz, use only a transformer-type power converter. **Do not use “solid-state” or “switching-type” power converters. They will damage your AC adapter/charger.** An optional CPS014, shown on page 51, is designed for use on 100-240 volts, 50/60 Hz.

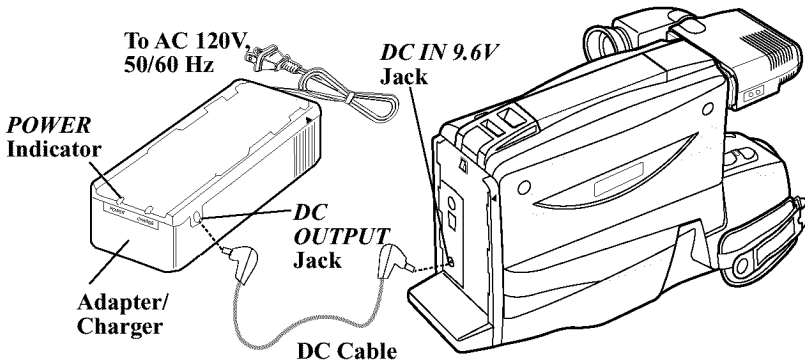

Caution: Do not use this adapter/charger for any other purpose other than charging the EP096FS or EP096FL battery pack or supplying power to the camcorder.

Attach Adapter/Charger

1. Attach one end of the adapter/charger's DC cable to the *DC OUTPUT* jack on the adapter/charger.
2. Attach the other end of the cable to the *DC IN 9.6V* jack on the camcorder.
3. Plug the adapter/charger's plug into an operating outlet. The *POWER* indicator on the adapter/charger lights when it is properly connected.

Notes: The adapter/charger cannot charge the battery and operate the camcorder at the same time. If you connect both, the adapter/charger powers the camcorder. Remove the adapter/

charger's cable from the *DC OUTPUT* jack to charge the battery.

When using the adapter/charger to power the camcorder, the battery level indicator might display . This indicator is used for battery operation and has no meaning when using the adapter/charger to power the camcorder.

Remove Adapter/Charger

1. Unplug the adapter/charger from the wall outlet.
2. Remove the DC cable from the adapter/charger and camcorder.

Power Your Camcorder

Use the Battery to Power Your Camcorder

Charge the Battery

The battery must be charged before it can be used the first time. Initial charging takes approximately two hours. The camcorder's operating time depends on how often you turn the power on and off and how much you use the monitor, zoom, and pause. To conserve battery power, turn the camcorder off during recording breaks.

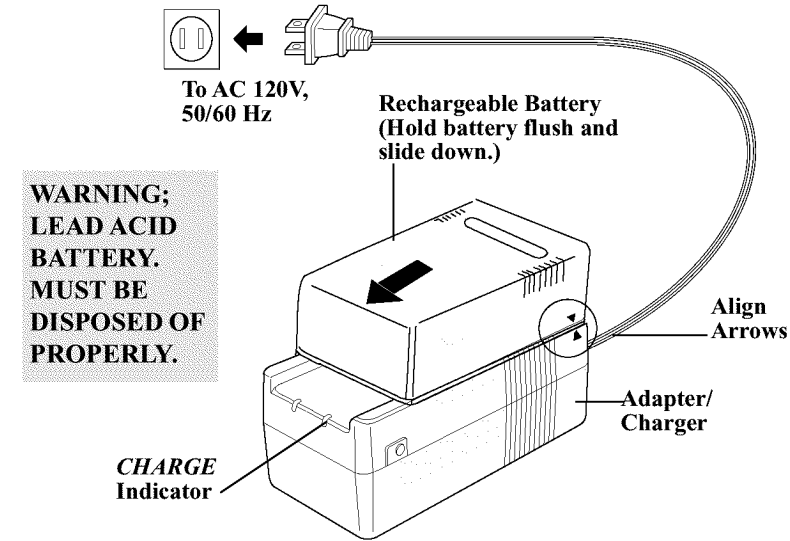

Caution: When a battery is attached to the adapter/charger, do not turn them upside down. The battery might fall off and be damaged or cause injury.

Charge the Battery

If the DC cable is attached to the *DC OUTPUT* jack on the adapter/charger, remove it.

1. Align reference mark on battery with mark on adapter/charger.
2. Hold the battery flush against the adapter/charger and slide it in the direction of the arrow.
3. Plug adapter/charger into nearest AC outlet (120V, 50/60Hz).

4. If the battery is properly connected, the adapter/charger's *CHARGE* indicator lights.

Note: Your battery will provide better service if you charge it before and after use and store it at room temperature.

5. Remove the charged battery by sliding it up and off the adapter/charger.
6. Attach the charged battery to the camcorder *as shown on the next page*.

Power Your Camcorder

Use the Battery to Power Your Camcorder (continued)

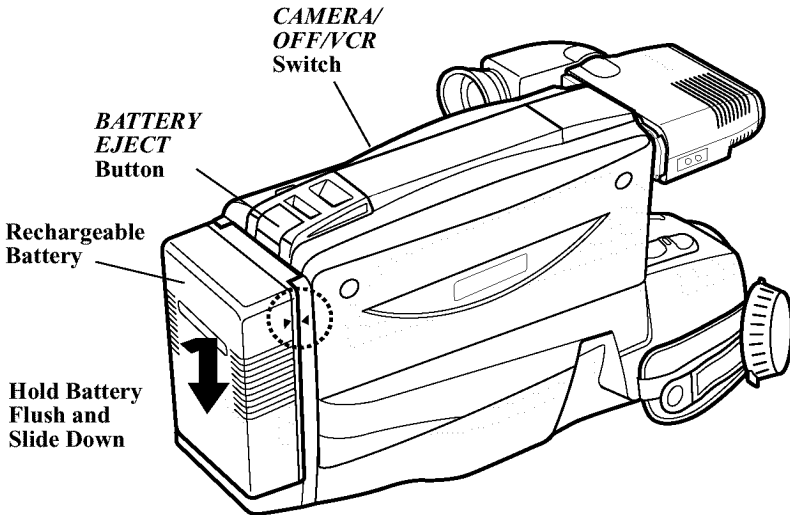

Attaching the Charged Battery

If the DC cable is attached to the camcorder, remove it before attaching the battery.

1. Align the reference arrow on the battery to the arrow on the back of the camcorder.
2. Hold the battery flush against the camcorder while you slide it down in the direction of the arrow.

3. Press and hold the small button on the *CAMERA/OFF/VCR* switch while you set it to *CAMERA*.

Removing the Battery

1. Set the *CAMERA/OFF/VCR* switch to *OFF*.
2. Press and hold the *BATTERY EJECT* button while removing the battery.

ATTENTION: THE RECHARGABLE BATTERY CONTAINED IN THIS PRODUCT IS RECYCLABLE. AT THE END OF ITS USEFUL LIFE, UNDER VARIOUS STATE LAWS, IT MAY BE ILLEGAL TO DISPOSE OF THIS BATTERY IN THE MUNICIPAL WASTE STREAM. CHECK WITH YOUR LOCAL SOLID WASTE OFFICIALS FOR DETAILS IN YOUR AREA FOR RECYCLING OPTIONS OR PROPER DISPOSAL.



Pb

Power Your Camcorder

Use the Battery to Power Your Camcorder *(continued)*



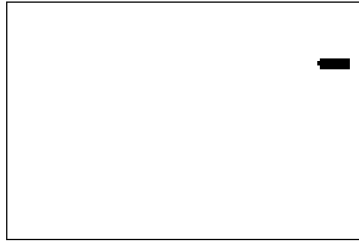

Battery Level Indicator

The battery level indicator appears in the viewfinder or on the LCD monitor and shows you the amount of power in the rechargeable battery.



Battery Level Indicator Display in Viewfinder or on the LCD Monitor

Note: If you can't see the battery level display, press *DISPLAY*.

- When  appears, the battery is fully charged.
- As the power is used  and  appear.
- When the battery power is almost gone,  flashes in the viewfinder or on the LCD monitor. Recharge the battery or use the adapter/charger before continuing to use the camcorder. Set the *CAMERA/OFF/VCR* switch to *OFF* to turn off the camcorder before replacing the battery.

Notes: When you record using the rechargeable battery, the battery level indicator still flashes to warn you of low battery power even if you do not have the battery level indicator displayed.

The battery level indicator isn't recorded on the tape.

The battery level indicator has no meaning when you use the adapter/charger or optional car cord to power the camcorder.

Cautions: When a battery reaches empty during use, the camcorder turns off. The battery should still have enough reserve power to eject the cassette when you press *STOP/EJECT*.

If the camcorder does not eject the cassette when you press *STOP/EJECT*, **do not force the cassette door open**. This will damage your camcorder.

Before attempting to eject the cassette, power the camcorder with the adapter/charger or recharge the battery.

Power Your Camcorder

Use the Battery to Power Your Camcorder *(continued)*

Battery Care

- Your battery will provide better service and longer performance if you charge it before and after use, and store it at normal room temperature.
- The battery should be charged at a temperature of 32°F-95°F (0°C-35°C) to prevent damage.
- Do not operate the battery at temperatures below 14°F (-10°C) or above 95°F (35°C). You might damage the battery if you use it at temperatures above 122°F (50°C). Operation time decreases at extremely low temperatures.
- After repeated chargings and use the operation time decreases. When the operation time becomes too short to be useful, it is time to replace the battery.

Battery Storage

- Store the battery at normal room temperature.
- Lead acid batteries discharge if not used. Recharge the battery at least once ever six months or you may not be able to recharge it.
- A battery stored for long periods might not supply power for the specified time. Additional rechargings might help restore the battery's operation time.

Battery Safety Precautions

- Batteries being recharged that have not been used for an extended period may continue to charge after the normal time. Do not charge a battery for more than 24 hours.
- If the *CHARGE* indicator on the adapter/charger starts flashing, remove the battery, and reattach it. If after several attempts, the indicator continues to flash, your battery cannot take a charge and must be replaced.
- Throwing the battery into a fire or exposing the battery to excessive heat – over 149°F (65°C) could be hazardous.
- Do not short the battery's terminals.
- Allow the battery to cool down before attaching it to the adapter/charger. The *CHARGE* indicator will not light and the battery will not charge if you attach a hot battery.
- Do not attempt to disassemble or modify the battery. There are no user-serviceable parts inside.
- Use the battery only with specified AC adapter/chargers and camcorders.
- If leakage from a damaged battery contacts your skin or clothing, wash it off immediately with running water.

Power Your Camcorder

Use the RCA Optional Car Cord Adapter

The optional DCC096 car cord *shown on page 50* allows you to power your camcorder from the cigarette lighter socket of a car, truck, or RV. It converts 12-volts to a 9.6-volt output.

Note: Consult the installation and operating instructions enclosed with the DCC096 for complete operating instructions.

Caution: The DCC096 car cord is designed to be used only with vehicles having 12-volt negative ground electrical systems.

Warning: To avoid possible damage to the camcorder, use only the DCC096 car cord. It has positive tip polarity and is capable of converting 12 volts to 9.6 volts.

Use the DCC096 Car Cord Adapter

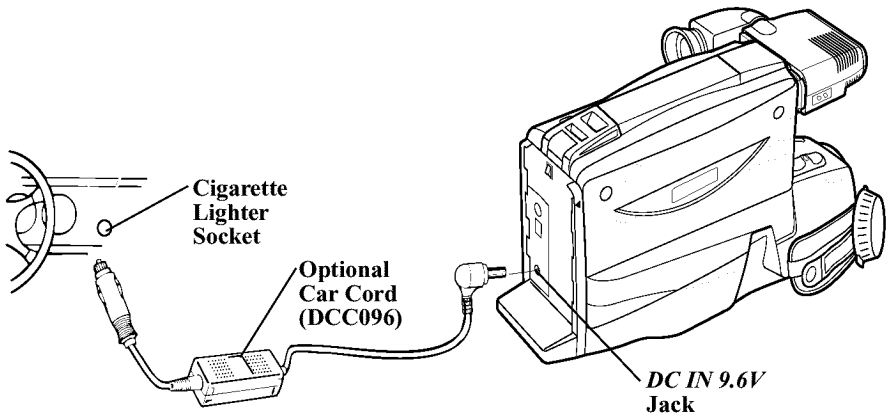

1. Set the *CAMERA/OFF/VCR* switch to *OFF* to turn off the camcorder.
2. If the battery or DC cable is attached to the camcorder, remove it.
3. Insert the small plug on the car cord to the *DC IN 9.6V* jack located on the back of the camcorder.
4. Take the vehicle's cigarette lighter out of the socket.
5. Insert the car cord's cigarette lighter plug into the vehicle's cigarette lighter socket.
6. To turn on the camcorder, press and hold the small button on the *CAMERA/OFF/VCR* switch while you set it to *CAMERA*.

Notes: The vehicle does not have to be running for the camcorder to operate from the DC car cord.

The battery level indicator has no meaning when you use the car cord to power the camcorder.

Videocassettes

Make sure you select good quality tapes for your camcorder. Use of poor quality tapes or tapes that have been damaged or mishandled can contaminate the video heads, resulting in a snowy picture or no picture at all during playback. Because there is no control over the type of tape purchased or rented by consumers, **head cleaning is not covered under warranty**. It is considered normal maintenance.

If a snowy picture or no-picture condition persists, consider the use of a dry chemical nonabrasive head-cleaning tape. Be sure to follow the directions with the head-cleaning kit carefully. Improper use of a head cleaner might damage your camcorder.

Erase Protection – Safety Tab

You can use your videocassettes over and over again. To erase a previous recording, just record over it.



To prevent accidental erasure, break off the tab.

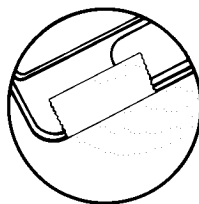

To record on the tape again, cover the hole with vinyl tape.

Recording and Playback Speed and Times

The camcorder records and plays back in VHS standard speed (SP). Listed below are the maximum recording times for popular VHS cassettes.

CASSETTE	RECORDING TIME
T-60	60 Min.
T-120	2 Hrs.
T-160	2 Hrs., 40 Min.
T-180	3 Hrs.

Videocassettes

Insert and Remove Cassettes

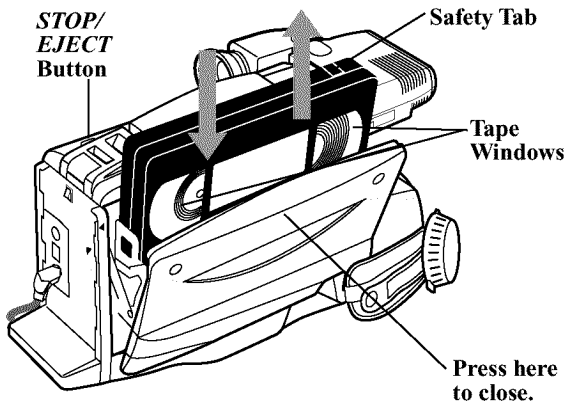

Caution: Insert the cassette only one way with the tape wheel facing up and the tape windows facing out. The cassette should slide easily into the holder. Gently push the cassette down until it locks into place.

1. Attach a power source to the camcorder.
2. Press the *STOP/EJECT* button. The cassette holder opens automatically.
3. Insert the cassette with the tape wheel facing up and tape windows facing out. Gently push the cassette down until it locks into place.
4. Gently close the cassette holder with your hand.

Cassette Care and Storage

- When you are finished with a cassette, rewind it, remove it from the camcorder, and label it.
- Store cassettes vertically in their protective cases at normal room temperatures. Do not leave your camcorder or cassettes in a car or outdoors for an extended period. Excessive heat or cold might damage your cassettes.
- Keep the cassette away from strong magnetic fields such as electric motors and other devices.
- Keep dust from entering the cassette compartment. All dust is abrasive and will cause excessive wear on the tape and the camcorder's recording or playback heads.
- Do not use cassettes with damaged or spliced tape.
- Do not use a cassette if it has been damaged or exposed to moisture. The tape might jam and/or damage your camcorder.
- Break off the safety tab to prevent accidental erasure of your recording.

Date and Time Display

Setting the Time and Date

You must set the correct date and time before it can be displayed and recorded on your tapes. The built-in clock cell must be charged *as described on the next page*.

NOTE: If you leave the camcorder on for 10 minutes without a cassette inserted when the date has not been set or the built-in clock battery is dead, the camcorder demonstration mode will start. To cancel the demonstration mode, disconnect power from the camcorder and reconnect it, or insert a cassette.

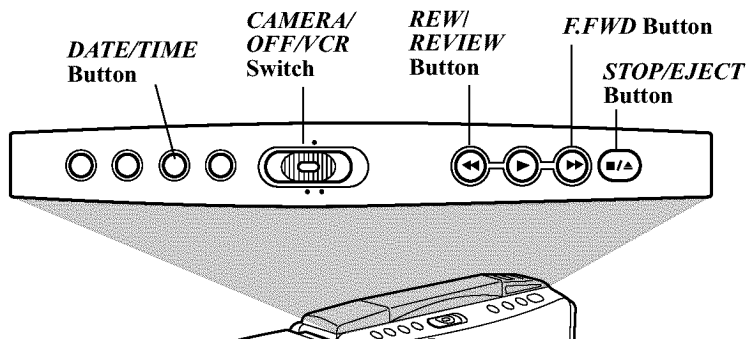

1. Attach a power supply to the camcorder.
2. Press and hold the small button on the *CAMERA/OFF/VCR* switch while you set it to *CAMERA*.
3. Press the *DATE/TIME* button to display the date and time on the LCD monitor or in the viewfinder.
A flashing cursor lets you know which part of the display you are setting. If the flashing cursor does not appear, press and hold *DATE/TIME* and then press *STOP/EJECT*.
4. Repeatedly press the *F.FWD* or *REW/REVIEW* until the correct month appears. Press and hold the button to advance the digits faster.
5. When the correct month is displayed, press *STOP/EJECT*. The cursor moves to the next part of the display.
6. Repeat steps 4 and 5 to set the correct month, day, year, hour, minute(s), and *AM/PM*.
7. After setting *AM* or *PM*, press the *DATE/TIME* button to remove the flashing cursor and start the internal clock.

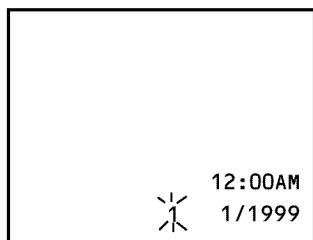

To Correct the Date or Time

To correct the date or time, press and hold the *DATE/TIME* button and then press *STOP/EJECT*. The display and the flashing cursor appear. Use *STOP/EJECT*, *F.FWD*, and *REW/REVIEW* to correct the time or date. Press *DATE/TIME* to remove the flashing cursor and start the clock.

Date and Time Display

Record the Time and Date, *AUTO* Date, Auto *TITLE*, or Date

The time and date, *AUTO* date, auto *TITLE*, date only, or no date can be recorded on your tape. Whenever one of these displays appear, it will be recorded.

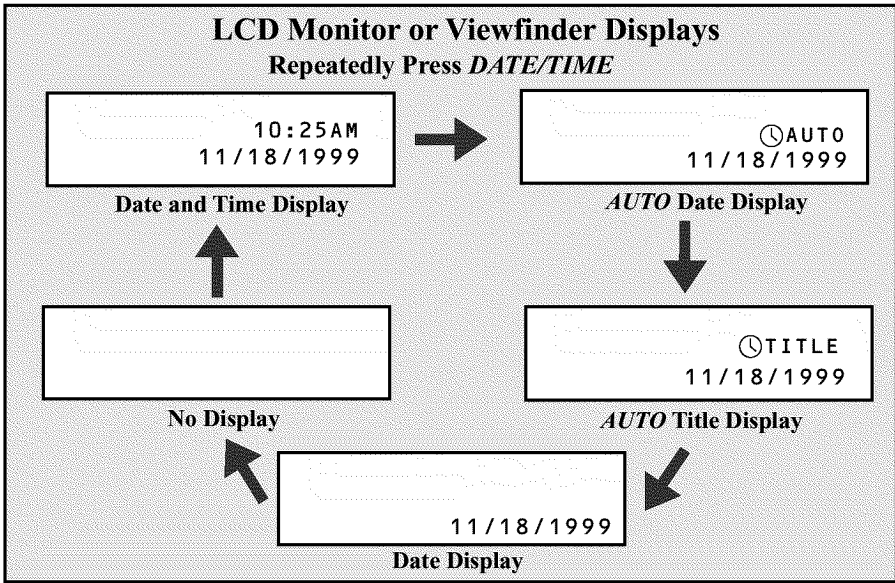

Selecting the Display to Record

1. Repeatedly press *DATE/TIME* to select the display you want to record.
 - **Date and Time Display**: The date and time will be displayed and recorded.
 - ⓐ **AUTO Date**: The date is automatically recorded for approximately 10 seconds at the beginning of the recording.
 - ⓐ **TITLE**: The date and title you have created are displayed and recorded for approximately 10 seconds at the beginning of the recording.
 - **Date Display**: The date is displayed and recorded.
 - **No Display**: No display is displayed or recorded.

Charging the Built-in Clock Battery

The camcorder has a built-in rechargeable battery **that must be charged approximately every two months.**

1. Attach a power supply and set the *CAMERA/OFF/VCR* switch to *OFF*.
2. Leave the power supply attached at least 24 hours.

Cautions: If this battery is not charged every two months, it will over-discharge and shorten its useful life.

Do not attempt to replace this battery. Take the camcorder to an authorized RCA Service Center.

Recording

Use the LCD Monitor or Viewfinder to See What You Record

You can watch what you are recording on the LCD monitor or in the viewfinder. When the LCD monitor is open more than approximately 45°, the viewfinder automatically turns off. Close the LCD monitor and the viewfinder automatically turns on.

Use the LCD Monitor

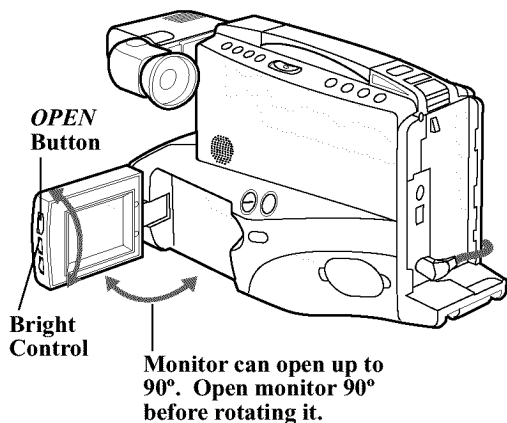

1. Press the *OPEN* button and open the LCD monitor. Make sure the monitor is open 90°. The viewfinder automatically turns off.
2. Rotate the monitor.
 - Tilt the monitor down to record from a high angle, such as over a crowd.
 - Tilt the monitor up to record from a low angle, such as when you are kneeling.
 - To enable both you and the person you're recording to see what's being recorded, rotate the LCD

Cautions: Do not force the monitor to open farther than 90°. This will damage the monitor and/or the camcorder.

Open the monitor 90° before rotating it up or down or reversing its direction. Make sure the monitor is not rotated or tilted before closing it.

Do not touch the LCD monitor with your fingers. Use a soft cloth to clean the monitor.

When carrying the camcorder with the shoulder strap, close and lock the monitor. This helps prevent possible damage to the monitor from bumping against your body as you move.

- monitor completely around so the front of the monitor faces the person you're recording. The viewfinder turns on automatically when you turn the monitor all the way around.
 3. To adjust the brightness of the image on the monitor, turn the bright control. This does not affect the brightness of the recording you are making.
 4. When you are finished, carefully rotate the monitor back into position and close and lock it into place.
- Note:** When recording on a bright sunny day, the LCD monitor might be hard to see. Use the viewfinder.

Recording

Using the Viewfinder

The camcorder's viewfinder is a miniature monitor that displays the picture seen by the camcorder when recording. When the LCD monitor is open more than 45°, the viewfinder automatically turns off.

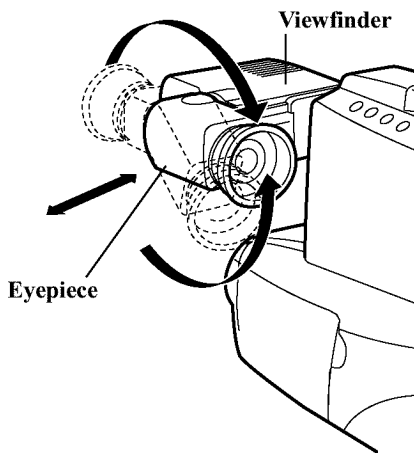

Cautions: Do not pull on the eyepiece. Do not force the eyepiece to rotate completely around. This might damage the viewfinder and/or the camcorder.

When carrying the camcorder with the shoulder strap, put the viewfinder back in its original position. This helps prevent possible damage to the viewfinder from bumping against your body as you move.

Adjusting the Viewfinder for Convenient Viewing

For convenient viewing, rotate the viewfinder horizontally, pull it out from the camcorder, and adjust the eyepiece.

Eyepiece Focus Control

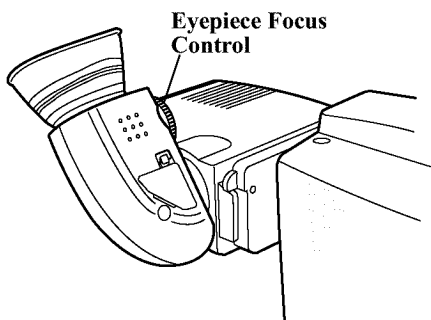

The eyepiece focus control lets you set the focus of the viewfinder for your vision. If you wear eyeglasses, you probably can operate the camcorder without them.

It is easiest to set the correct focus by focusing on one of the viewfinder's on-screen displays. Look through the viewfinder and adjust the eyepiece focus control for your vision.

The eyepiece focus control does not affect the focus of the picture actually recorded by the camcorder.

LCD Monitor or Viewfinder Displays

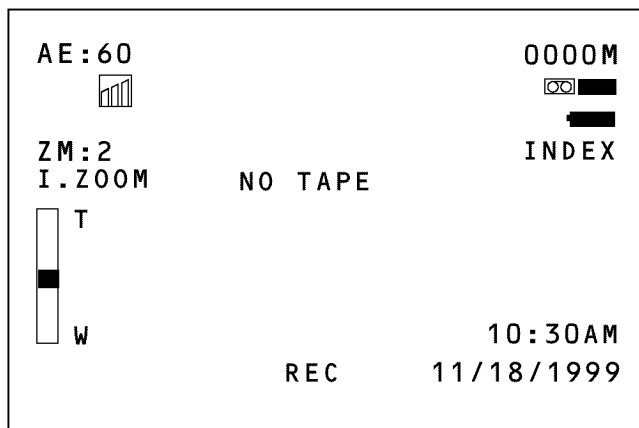

AE:60 (Auto Exposure) Shutter Speed

Press the *DISPLAY* button to display the shutter speed selected by the camcorder.

Battery Level Indicator (■)

Press the *DISPLAY* button to display the amount of time left on the rechargeable battery. *Details are on page 15.*

Digital Effects (ZM:2)



Press the *DISPLAY* button to display the indicator for the digital effect mode selected. Press the *DIGITAL EFFECTS* button to select a digital effect mode.

- Select *16X9* to make a recording that you're going to play back on a 16X9 TV.
- Select *NEGPOS* to reverse the image from positive to negative.

- Select *ZM:2* to activate the extended zoom mode – wide angle to 240 times with instant zoom. *ZOOM* appears when you zoom over 16 times.
- Select *MIRROR* to record a symmetric image on the left and right.
- Select *MOSAIC* to record a mosaic image.
- *Details are on pages 30-33.*

Fade Indicator (▮)

Press the *DISPLAY* button to display the indicator for the fade mode selected. Press the *FADE* button to select a fade.

- Select  to white fade.
- Select  to wipe fade.
- Select  to zoom fade.
- Select *B/W* to black-and-white fade.
- *Details are on pages 34-35.*

Recording

INDEX Indicator

Press the *DISPLAY* button to display this indicator when the camcorder is placing an index mark on the tape. *Details are on page 28.*

Status Displays

The following displays appear to tell you the status of the camcorder.

- The *REC* indicator appears during recording.
- The ►► indicator appears when the camcorder is fast-forwarding.
- The ◀◀ indicator appears when the camcorder is rewinding.
- The indicator appears during record-pause.

Tape Counter with Memory Stop (0000M)

Press the *DISPLAY* button to display the tape counter. The tape counter helps locate segments of tape.

- Memory stop is turned on whenever the tape counter appears.
- *Details are on page 36.*

Tape Warnings (TAPE, NO TAPE, and TAPE END)

- *TAPE* flashes when you try to record with the safety tab removed.
- *TAPE* flashes when a damaged tape is inserted. Remove the tape and replace it with a new one.
- *NO TAPE* flashes when you try to record with no cassette inserted.

- *TAPE END* flashes when there is approximately five minutes of recording time left on the tape.
- *TAPE END* briefly appears when you reach the end of the cassette when you're recording.

Time and Date Display

Press the *DATE/TIME* button to display the time and date, *AUTO* date, auto *TITLE*, date only, or no date when the camcorder is in record-pause.

- These displays are recorded on the tape when they appear in the viewfinder or on the LCD monitor.
- *Details are on pages 20-21.*

Tape-Remaining Indicator (00 ■■■■)

Press the *DISPLAY* button to display the tape-remaining indicator. This display shows the approximate amount of tape left for recording or playback. *Details are on page 27.*

Zoom (⏏), ZOOM, and I.ZOOM Indicators

- The zoom indicator (⏏) appears when you use the power zoom buttons (*T* and *W*).
- *ZOOM* appears when you zoom with the *T* button more than 16 times.
- *I.ZOOM* appears when you press the *INST. ZOOM* button to immediately enlarge the picture 1.5 times.
- *Details are on page 29.*

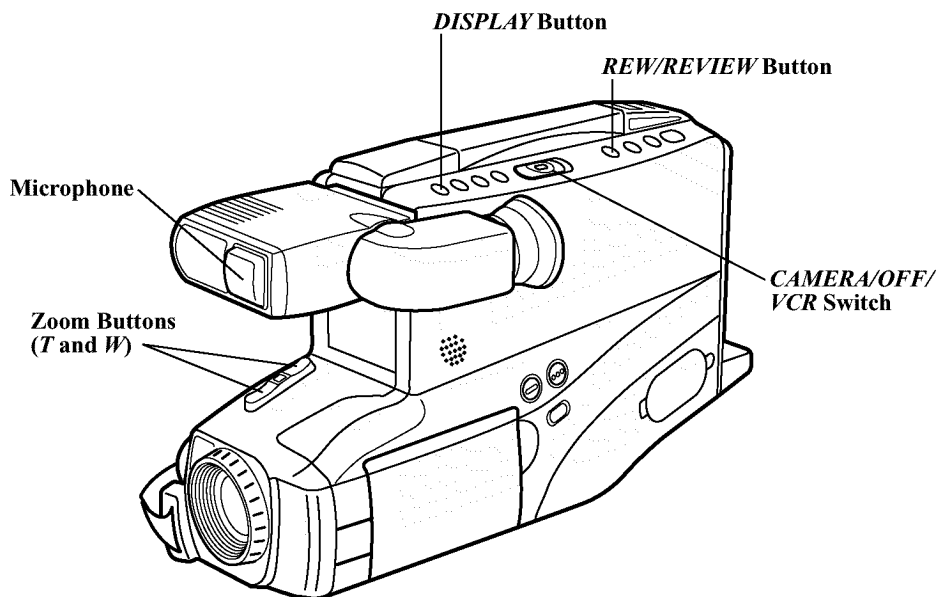

***DISPLAY* Button**

The *DISPLAY* button lets you remove the battery level, steady pix, tape speed, tape counter with memory stop, remaining tape display, index, fade, zoom and digital effects indicators from the viewfinder or LCD monitor.

- Press *DISPLAY* to remove the indicators.
- Press *DISPLAY* again to display the indicators.

Microphone

The microphone picks up the sound during a recording. It is more sensitive to sounds coming from the direction the lens is pointed.

Quick Review Feature

Press and release *REW/REVIEW* when the camcorder is in record-pause to review the last few seconds of a recording. The *CAMERA/OFF/VCR* switch must be set to *CAMERA*.

The camcorder will play back the last few seconds of the recording, return the tape to its previous position, and return to record-pause.

Recording

Auto Shot™ Feature

The camcorder automatically adjusts focus, white balance, iris, shutter speed, and light according to the recording conditions.

Auto Focus

The camcorder focuses on the subject in the center of the LCD monitor or viewfinder. Auto focus operates on the telephoto (*T*) side from approximately 2-1/2 feet to infinity. It operates on the wide-angle (*W*) side from 3/8 inch from the lens surface (macro-focus) to infinity.

Note: When the displays appear, the AE indicator for the shutter speed selected by the camcorder (*1/60, 1/100, 1/120, 1/180, 1/250, 1/350, 1/500, 1/750, 1/1000, 1/1500, 1/2000, or 1/4000*) appears in the viewfinder or on the LCD monitor.

The following conditions may prevent auto focus from operating properly.

- Recording a subject through a window.
- Recording a subject that has a close foreground and a far background.
- Recording two subjects at different distances that overlap.
- Subject that isn't in center of scene.
- Recording in low-light situations.
- Recording a scene with fast motions, like a tennis swing.

Macro Focus

The macro-focus feature lets you focus on objects as close as 3/8 inch from the camcorder lens.

1. Press and hold zoom button *W* until the lens is completely zoomed out.

2. Position the subject in the center of the scene.

Notes: Zooming is not possible when using macro-focus. To change the size of the subject, move the camcorder lens closer or farther away from it.

For best results increase illumination when recording with macro-focus.

Tape-Remaining Display

The tape-remaining display shows the approximate amount of tape remaining for recording or playback.

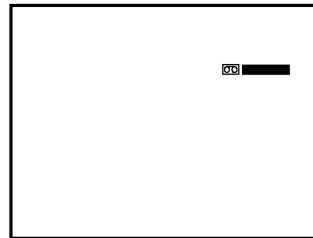



Tape-Remaining Display in LCD Monitor or Viewfinder

- Press *DISPLAY* to display the tape-remaining indicator in the viewfinder or on the LCD monitor.
- The camcorder takes approximately ten seconds to calculate the tape remaining when you first start playing or recording a tape.
“_____” appears while the camcorder calculates the amount of tape-remaining.

Once tape-remaining has been calculated, it automatically updates and is readily available as long as the same tape remains in the camcorder.

(Continued on next page)

Recording

- When  appears, all or most of the tape remains.
-  and  appear as the tape is being used.
- When the tape is almost at its end, *TAPE END* flashes in the viewfinder or on the LCD monitor.

Electronic Indexing

Each time you begin recording (after the camcorder has been turned off for at least four hours), the camcorder automatically records an index mark at the beginning of the new recording.

When you play back the indexed tape in a VCR that has a compatible indexing feature called “VHS Index Search System” the invisible marks can be located automatically. See your VCR Owner’s Manual for index playback instructions.

When the *DISPLAY* button is pressed so the displays appear, *INDEX* appears briefly to let you know the camcorder is recording an index mark.

Note: The camcorder does not record index marks every time you stop and start recording. An index mark is recorded only once – at the start of each day’s recording session (or whenever the camcorder has been turned off for four hours).



***INDEX* Display in
LCD Monitor or Viewfinder**

Recording

Zooming

Press one of the zoom buttons to zoom in and out for close ups or wide-angle shots. Instant zooming immediately magnifies the picture 1.5 times.

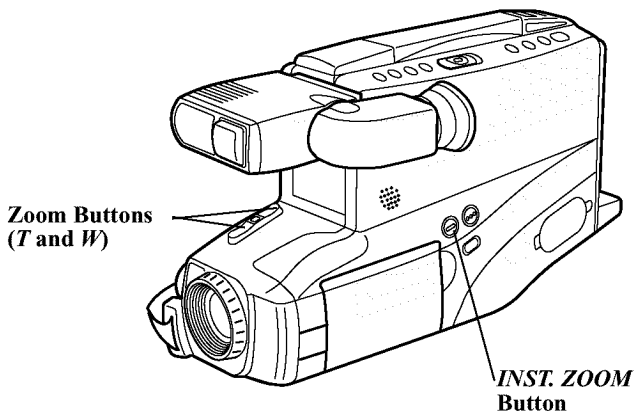

Using the Zoom Buttons (*T* and *W*)

1. To zoom in or out from wide angle to 72 times, press zoom button *T* or *W*.
 - To move the lens in the telephoto (close-up) direction, press *T*.
 - To move the lens in the wide angle direction, press *W*.

When *DISPLAY* is pressed so the displays appear, the zoom level indicator appears in the viewfinder or on the LCD monitor during normal zooming. *ZOOM* appears when you zoom more than 16 times.

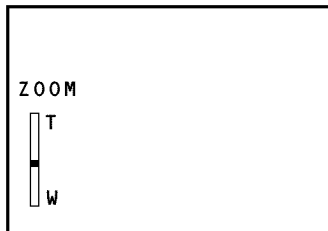

Zoom Level Indicator in LCD Monitor or Viewfinder

Using the Instant Zoom Button (*INST. ZOOM*)

1. To magnify the subject 1.5 times, from any normal zoom position, press the *INST. ZOOM* button.

When *DISPLAY* is pressed so the displays appear, *I. ZOOM* appears in the viewfinder or on the LCD monitor during instant zooming.

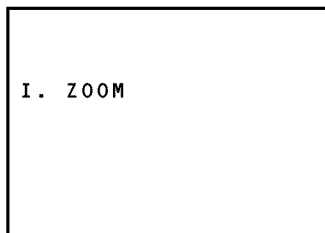

Instant Zoom Display in LCD Monitor or Viewfinder

Recording

Digital Effects

The camcorder has a digital processor that allows you to record using five special digital effects: 16X9, a negative image, 240 times digital zoom (with instant zoom), a symmetric mirror image, or a mosaic image. Each effect is described in detail *on the next pages*.

Selecting a Digital Effect

1. Make sure the displays appear in the viewfinder or on the LCD monitor. If they do not, press the *DISPLAY* button.
2. Repeatedly press the *DIGITAL EFFECTS* button. The indicator for the digital effect you select appears in the viewfinder or on the LCD monitor.

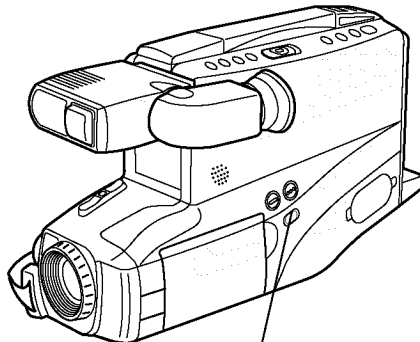

**DIGITAL
EFFECTS
Button**

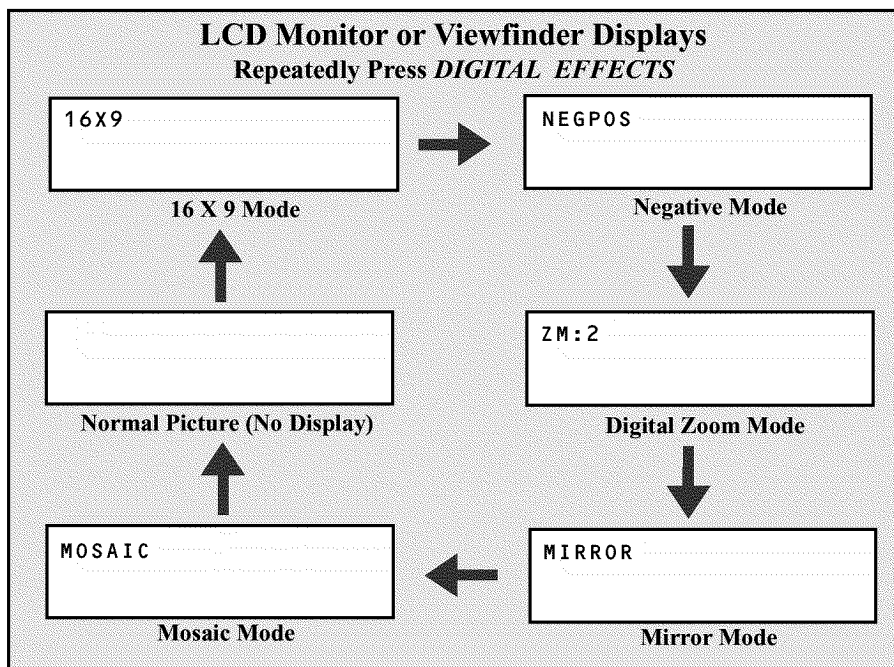

Recording

Digital Effects (continued)

16X9 Mode

The camcorder has a wide recording mode that lets you make recordings compatible with the 16X9 format. When 16X9 is activated, the camcorder records black bars at the top and bottom of the picture to produce the wide-screen effect. This is also known as “letterbox” recording.

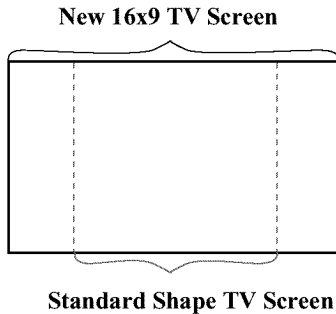

Caution: Do not use this mode unless you have a compatible 16 X 9 TV. When played on a regular TV, black bars appear in the picture.

Recording in 16X9 Mode

1. Place the camcorder in record pause. Make sure the displays appear in the viewfinder or on the LCD monitor. If they do not, press *DISPLAY*.
2. Repeatedly press the *DIGITAL EFFECTS* button until *16X9* appears.
3. Press *REC/PAUSE* to start recording.
4. To turn off *16X9* recording, press *REC/PAUSE* to pause recording, and repeatedly press *DIGITAL EFFECTS* until no digital effects display appears.

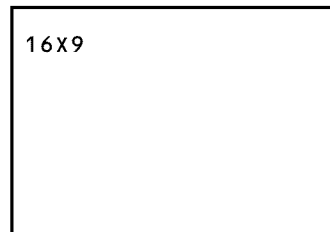

**16X9 Display in
LCD Monitor or Viewfinder**

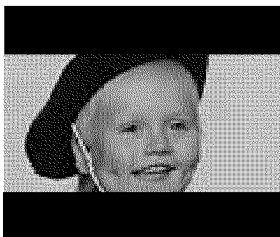

16X9 Mode

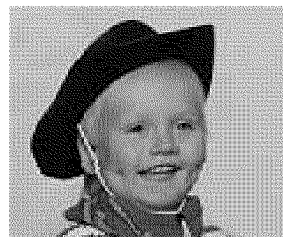

Normal Mode

Recording

Digital Effects (continued)

Negative Mode

The camcorder has a negative mode that lets you turn the image negative.

1. Place the camcorder in record-pause. Make sure the displays appear in the viewfinder or on the LCD monitor. If they do not, press *DISPLAY*.
2. Repeatedly press *DIGITAL EFFECTS* until *NEGPOS* appears.
3. Press *REC/PAUSE* to start recording.
4. To turn off negative recording, press *REC/PAUSE* to pause recording, and repeatedly press *DIGITAL EFFECTS* until no digital effects display appears.



Negative Mode



Normal Mode

Digital Zooming

The camcorder has digital zooming that allows you to zoom in on a subject with magnification up to 160 times. Normal zooming is up to 72 times.

NOTE: This function can magnify an image up to 240 times when instant zoom is used at the same time

1. Place the camcorder in record-pause. Make sure the displays appear in the viewfinder or on the LCD monitor. If they do not, press *DISPLAY*.
 2. Repeatedly press *DIGITAL EFFECTS* until *ZM:2* appears. Use the zoom buttons to zoom in and out. *ZOOM* appears when you zoom above 16X.
 3. Press *REC/PAUSE* to start recording.
 4. To turn off digital zooming, press *REC/PAUSE* to pause recording, and repeatedly press *DIGITAL EFFECTS* until no digital effects display appears.
- NOTE:** As the zoom level increases during digital zooming, the picture will gradually become less sharp. Use the high zoom levels mainly for special effects.



Digital Zooming Mode



Normal Mode

Recording

Digital Effects *(continued)*

Mirror Mode

The camcorder has a mirror mode that lets you display a symmetric image on the left and right, obtained by placing a mirror at the center of the screen.

1. Place the camcorder in record-pause. Make sure the displays appear in the viewfinder or on the LCD monitor. If they do not, press *DISPLAY*.
2. Repeatedly press *DIGITAL EFFECTS* until *MIRROR* appears.
3. Press *REC/PAUSE* to start recording.
4. To turn off mirror recording, press *REC/PAUSE* to pause recording, and repeatedly press *DIGITAL EFFECTS* until no digital effects display appears.

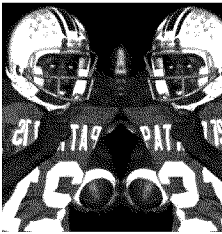

Mirror Mode

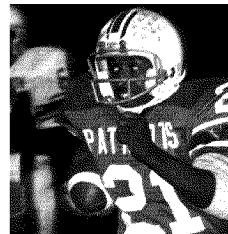

Normal Mode

Mosaic Mode

The mosaic feature lets you add a mosaic effect to your recording.

1. Make sure the displays appear in the viewfinder or on the LCD monitor. If they do not, press *DISPLAY*.
 2. Repeatedly press *DIGITAL EFFECTS* until *MOSAIC* appears.
 3. Press *REC/PAUSE* to start recording.
 4. To turn off mosaic recording, press *REC/PAUSE* to pause recording, and repeatedly press *DIGITAL EFFECTS* until no digital effects display appears.
- Note:** Mosaic recording cannot be used with digital zooming, instant zooming, or the zoom fade features.

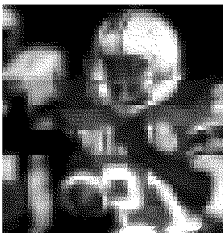

Mosaic Mode

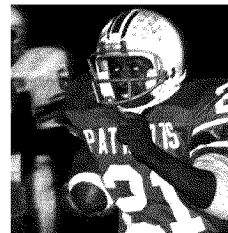

Normal Mode





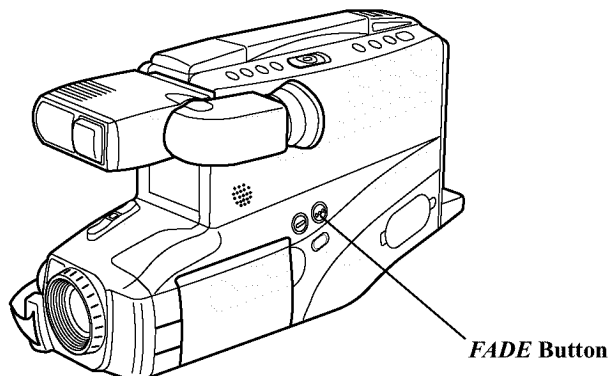

Fading In and Out of Scenes

You can add a professional touch to your recordings when you fade in and out of scenes. Both the picture and sound gradually appear or disappear. The speed of the fade is controlled by the camcorder.



Selecting a Type of Fade

You can select white fade, black, yellow, blue, and green wipe fade, zoom fade, or black-and-white fade.

1. Press *REC/PAUSE* to pause recording. Make sure the displays appear in the viewfinder or on the LCD monitor. If they do not, press *DISPLAY*.
2. Repeatedly press the *FADE* button. The indicator for the fade you select will appear.
 - Select  (white) to fade in and out to/from a white screen.
 - Select  (black wipe) to fade in and out to/from a black screen.
 - Select  *YEL*,  *BLU*,  *GRN* (yellow, blue, or green wipe) to fade in and out to/from a yellow, blue, or green screen.
 - Select  (zoom) to fade in and out while zooming.
 - Select *B/W* (black-and-white) to fade in and out to/from a black-and-white picture.
 - Select no fade indicator if you do not want to fade in or out.

Notes: Zoom fade does not operate with *MIRROR* and *MOSAIC* special effects modes. Pressing the *DIGITAL EFFECTS* button turns off the fade mode. Set the digital effect you want, and then set the fade.

Recording

Fade In and Out of Scenes (continued)

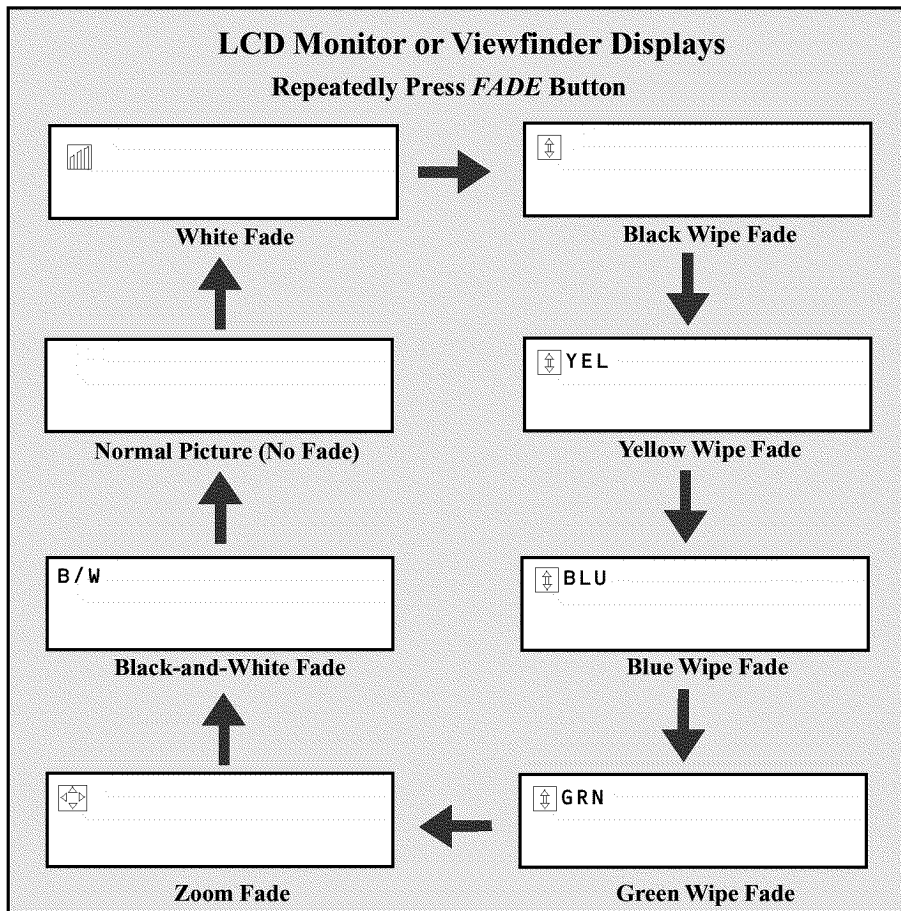

Fade In

1. Press *REC/PAUSE* to pause recording.
2. Repeatedly press *FADE* to select the fade you want to use.
Note: The last fade used appears the first time you press *FADE*.
3. Press *REC/PAUSE* to start recording. The picture and sound gradually appears in place of the blank screen.

Fade Out

1. During recording, repeatedly press *FADE* to select a fade.
Note: The last fade used appears the first time you press *FADE*.
2. Press *REC/PAUSE* to stop recording. The picture and sound gradually disappears.

Recording

Tape Counter

The tape counter acts as a handy reference to help you locate tape segments. The memory-stop feature helps locate a certain point on the tape. When the tape counter appears, the tape stops automatically during rewind or fast forward when the tape counter reaches *0000M*.

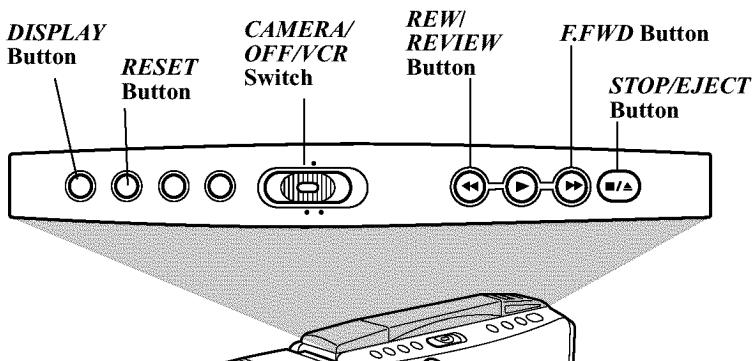

Using the Memory-Stop Feature

1. Press *REC/PAUSE* to pause recording. Make sure the displays appear in the viewfinder or on the LCD monitor. If they do not, press *DISPLAY*.
2. Locate the place on the tape you want to return to, and press *RESET* to reset the counter to *0000M*.

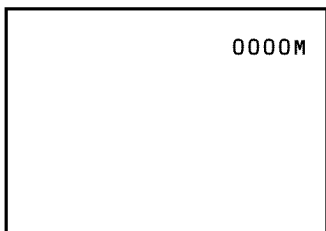

*Tape Counter
With Memory Stop*

3. Continue to record or play the tape. When you want to return to the place you marked, press the *REC/PAUSE* button to stop recording or the *STOP/EJECT* button to stop playback.
4. Press and hold the small red button while you set the *CAMERA/OFF/VCR* switch to *VCR*.
5. Press the *REW/REVIEW* button. The tape rewinds to the counter reading of *0000M*.

Notes: Press *DISPLAY* to display or remove the tape counter. Memory stop is turned on whenever the tape counter appears.

The camcorder stops rewinding or fast forwarding when the counter reaches *0000M*. To continue rewinding or fast forwarding, press the button again.

The tape counter automatically resets to *0000M* whenever a cassette is inserted.

3. Continue to record or play the tape. When you want to return to the place

Recording

Editing Features

The camcorder incorporates a complete package of advanced editing features to make it easy and fun to edit your home videos like a professional. The major features *are described on the following pages.*

- Camera Edit
- Titler

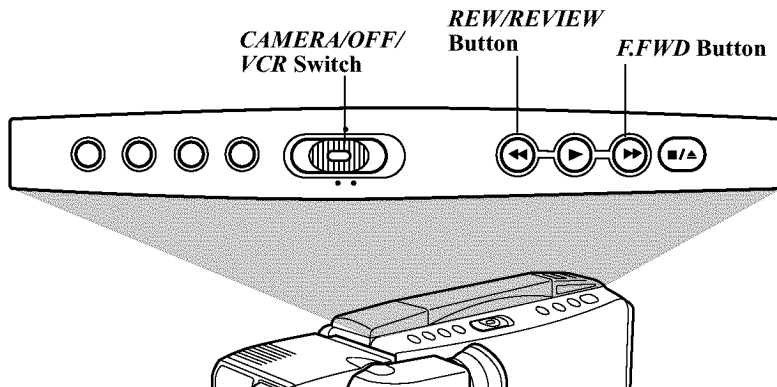

Camera Edit Feature

The camera edit feature allows you to position the tape when the camcorder is in record-pause. Press and hold the small red button on the *CAMERA/OFF/VCR* switch while you slide it to *CAMERA*.

- Press and hold *REW/REVIEW* to visually search the recorded tape in reverse.
- Press and hold *F.FWD* to visually search forward on the recorded tape.
- Press and hold *PLAY* to view the recorded tape at normal speed.

When you release the button, the camcorder returns to record-pause at that point on the tape.

Recording

Editing Features (continued)

Titler

The camcorder's built-in titler can store a title in memory. The created title can be displayed and recorded at any time.

The built-in character register contains more than 45 different characters. Your title can contain up to 32 characters on two lines.

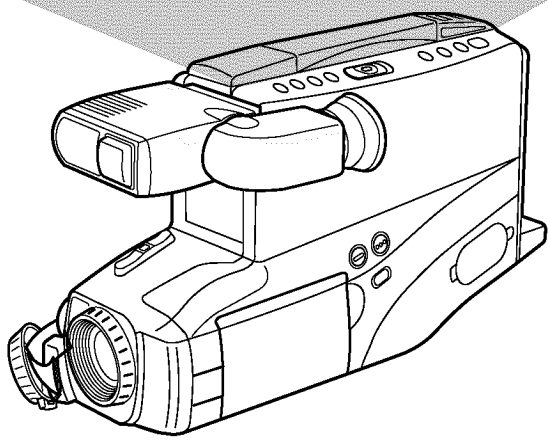
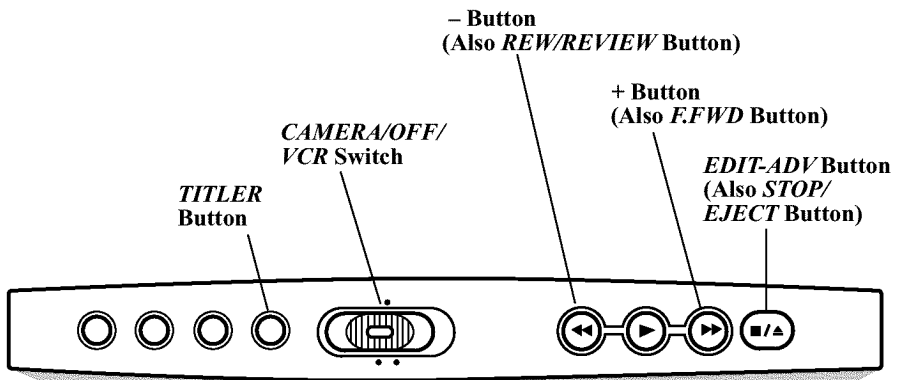

Recording

Editing Features *(continued)*

Titler *(continued)*

Creating a Title

1. Attach a power source to the camcorder. Press and hold the small red button on the *CAMERA/OFF/VCR* switch while you slide it to *CAMERA*.
 2. Press *TITLER* to display the titler graphics in the viewfinder or on the LCD monitor. A flashing cursor appears.
 3. Press *EDIT-ADV* to move the flashing cursor to the place where you want to begin your title.
 4. Select the first character for your title by pressing the + or – button until the character you want appears in the viewfinder or on the LCD monitor.
 5. After you have selected the first character, press *EDIT-ADV* to move the flashing cursor to the place where you want the next character to appear.
 6. Repeat steps 4 and 5 until you have completed the title.
 7. When you are finished, press *TITLER* to store the title and remove the title graphics from the viewfinder or LCD monitor.
- Remember:** Be sure to remove the titler graphics from the viewfinder or LCD monitor for normal recording.

See the chart below for the characters available.

Correcting an Error

1. Press *TITLER* to display the titler graphics in the viewfinder or on the LCD monitor.
 2. Press *EDIT-ADV* to move the flashing cursor over the character you want to correct.
 3. Press the + or – button until the correct character appears.
- Note:** If you want to delete a character, press + or – until the blank space appears.

Chart of Characters in Titler's Register

A	B	C	D	E	F	G	H	I	J	K	L	M
N	O	P	Q	R	S	T	U	V	W	X	Y	Z
0	1	2	3	4	5	6	7	8	9	?	`	./,
– ; : < > ! (BLANK)												

Editing Features *(continued)*

Titler *(continued)*

Recording a Title on a Tape in the Camcorder

1. Attach a power source to the camcorder. Press and hold the small red button on the *CAMERA/OFF/VCR* switch while you slide it to *CAMERA*.
2. Locate the place on the tape where you want to record the title.
Note: If you record a title on a prerecorded tape, the audio and video is erased where the title is inserted. A three-to-four second pause of blank tape appears before the existing audio and video return.
3. Press *TITLER* to display the titler graphics in the viewfinder or on the LCD monitor.
4. Press *REC/PAUSE* to start recording the title.
5. After you have recorded the title for the desired length of time, press *TITLER* to remove the titler graphics. The camcorder will now record normally. If you do not want to continue recording, press *REC/PAUSE*.
Remember: Remove the titler graphics for normal recording.
Note: You can also use the automatic title recording feature to automatically record the title and date for 10 seconds when you begin recording. Press the *DATE/TIME* button to display  *TITLE* before starting to record.

Record a Title While Copying a Tape from the Camcorder to Another VCR

1. Attach a power source to the camcorder.
2. Place the tape you want to copy in the camcorder and press and hold the small red button on the *CAMERA/OFF/VCR* switch while you slide it to *VCR*.
3. Place a blank tape in the VCR, and place the VCR in record-pause.
4. Start copying the tape from the camcorder to the VCR. *Details are on pages 46-47.*
5. When you see the place on the tape you want to insert the title, press *TITLER*.
6. After you have recorded the title for the desired time, press *TITLER* to stop recording the title.
7. Stop the camcorder and VCR when you are finished copying the tape.
Important Note: Remove the titler graphics for normal recording.

Recording

Recording Tips

- Try to make sure indoor scenes are well-lit. This improves picture quality and color reproduction.
- Do not move the camcorder rapidly from side-to-side while recording. A steady, gradual “pan” avoids blurring and “jitter.”
- Use the viewfinder or LCD monitor to make sure the camcorder is level while recording so that your scenes won’t appear “tilted.”
- Do not bump or tap the camcorder’s microphone while recording so that your scenes won’t appear tilted.
- Include close-ups of individuals when taping family outings or group functions.
- Fading in and out of scenes makes your videos appear more professional.
- Learn to use the special digital effects available with your camcorder to add variety to your recordings.
- Be aware of video and audio backgrounds. Background details barely noticed while you are taping may show up as visual “clutter” on your recording. Background noises (especially TV sets, radios, household appliances, traffic sounds, etc.) can detract from the sound you want to record.
- Avoid long “still” shots of landmarks and scenic attractions. Recordings are more interesting if they include people and details. “Local color” will give travel videos lasting appeal. Consider recording a familiar or landmark scene from an unfamiliar vantage point.

Travel Tips

- Write down your camcorder’s serial number and keep it separate from the camcorder when traveling. If your camcorder is lost or stolen, you will be able to identify it.
- Use extra care when you use your camcorder or accessories at a beach or pool. Spray, sand, and dust should be avoided. If your lens has been exposed to the elements, clean it only with proper lens cleaning supplies.
- Make sure you have any adapters that you might need before taking your camcorder to other countries. Consult your dealer for advice.
- Carry your camcorder in a carrying case when traveling. *See page 50 for a case designed especially for this camcorder.* An ordinary suitcase or carry bag does not offer the protection your camcorder needs. Treat your camcorder as carry-on luggage to protect it from rough handling.

Playback

Use the LCD Monitor or Viewfinder for Playback

You can watch tapes in color using the LCD monitor or black-and-white using the viewfinder. When the LCD monitor is open more than 45°, the viewfinder automatically turns off. Close the LCD monitor, the viewfinder automatically turns on. Rotate the monitor completely around and place it against the camcorder for convenient playback. During playback, you can hear the sound from the tapes on the built-in speaker when you use the LCD monitor.

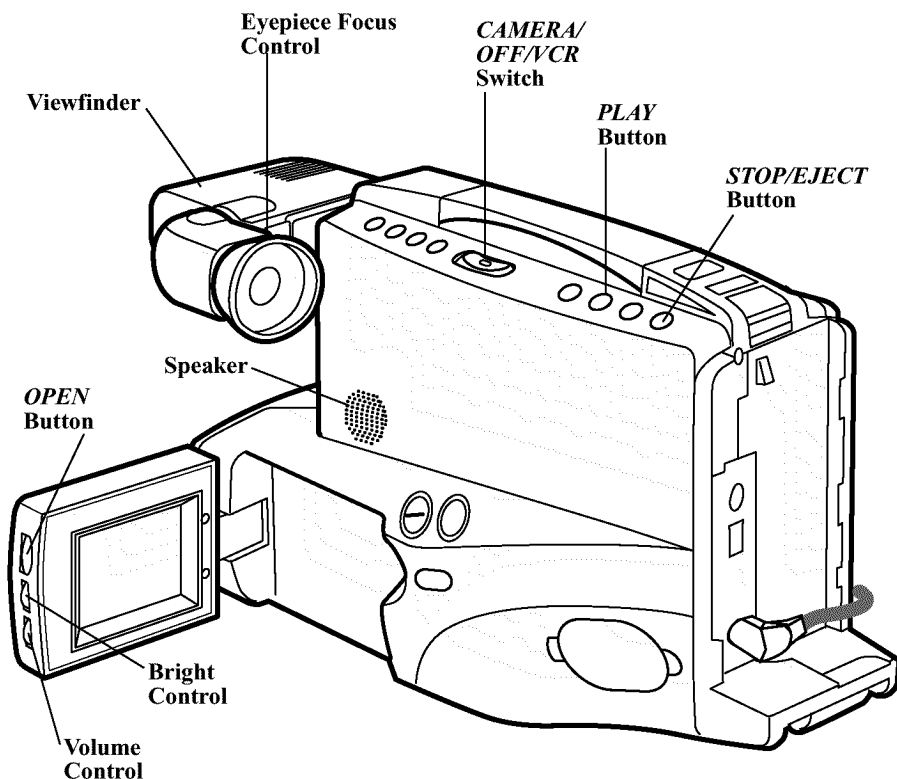

Use the LCD Monitor or Viewfinder for Playback (continued)

To Play Back a Tape

1. Attach a power supply.

Attach the adapter/charger, charged battery, or optional car cord.

2. Insert a tape.

- Press *STOP/EJECT* to open the cassette compartment.
- Insert the cassette with the safety tab facing up and the tape windows facing out.
- The camcorder can only play back tapes recorded in the SP speed.
- Press the cassette down gently until it locks into place, and close the cassette compartment door.

3. Press and hold the small red button on the *CAMERA/OFF/VCR* switch while you set it to *VCR*.

4. Use the LCD monitor or viewfinder to view what you are playing back.

Use the LCD Monitor

- Press the *OPEN* button to open the LCD monitor. Make sure the monitor is open at least 45°. The viewfinder automatically turns off.
- You can rotate the monitor around when it is open 90° and place it back against the camcorder.
- Fit the shoulder extension pad to your shoulder for convenient viewing using the LCD monitor.
- To adjust the brightness of the image in the monitor, turn the bright control.

- To adjust the speaker volume, turn the volume control.

Note: The monitor may become warm when left open for an extended period of time. This is normal.

Use the Viewfinder

- Make sure the monitor is closed and locked. If the monitor is open more than 45°, the viewfinder automatically turns off.
- Grasp the viewfinder and rotate it horizontally.
- Pull the viewfinder out from the camcorder and rotate the eyepiece to a comfortable viewing position.

Caution: Pulling on the eyepiece might cause damage to the eyepiece or camcorder.

- Turn the eyepiece focus control to adjust the focus of the viewfinder for your vision.

Note: You cannot hear the sound from the internal speaker when using the viewfinder for playback.

5. Press *PLAY* to begin playback.

- If necessary, adjust tracking.
- During playback, use the playback features on the following pages.

6. Press *STOP/EJECT* when you are finished.

Playback

Playback Features

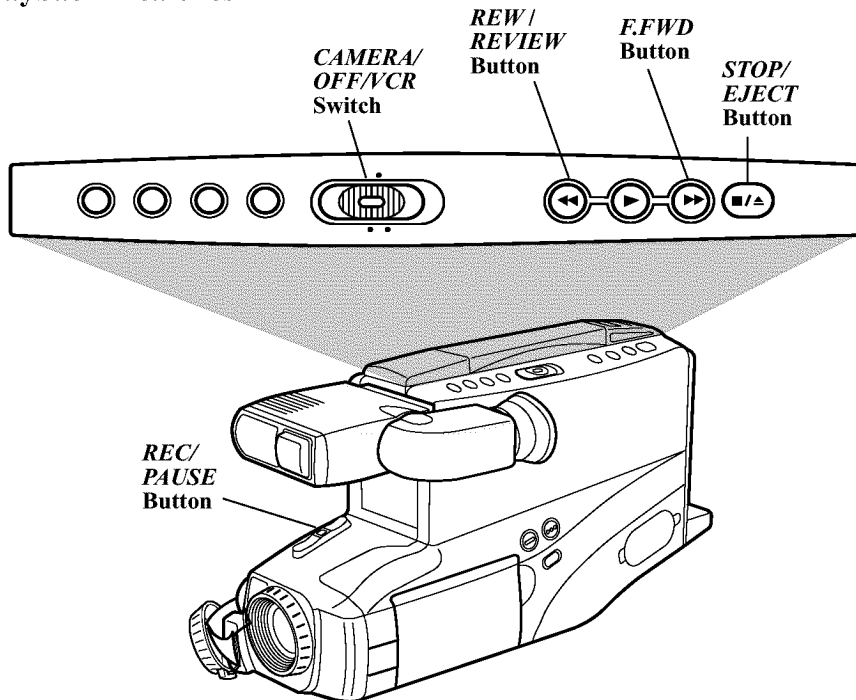

Tape Positioning

Press the small red button on the *CAMERA/OFF/VCR* switch while you set it to *VCR*.

- Press and quickly release *REW/REVIEW* or *F.FWD* to rewind or fast-forward the tape.
- Press *STOP/EJECT* to stop the tape.

Visual Searching

- During playback, press and hold *F.FWD* or *REW/REVIEW* if you want to search the tape visually in forward or reverse.
- Release the button to return to normal playback.

Stop-Action Pause

- During playback, press *REC/PAUSE* to “stop the action” and view one frame of the tape.
- Press *REC/PAUSE* again to return to normal playback.

Caution: Pause is designed for momentary interruptions and should not be used for an extended period of time. If the camcorder remains in pause for more than five minutes, it automatically enters the stop mode and turns off to prevent excessive tape wear.

Playback

Playback Features *(continued)*

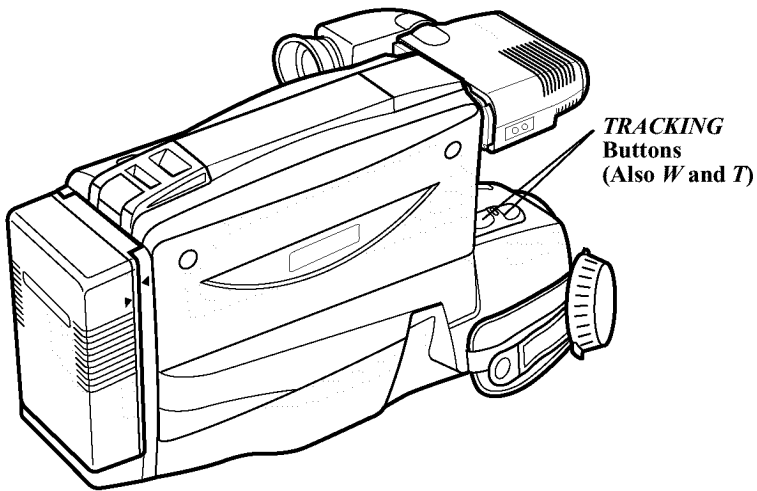

Tracking

During playback, streaks might appear in the playback picture. Press either *TRACKING* button (*W* or *T*) to move the streaks up or down and out of the picture.

- During stop-action playback, pressing one tracking button might reduce picture “jitter” (picture bouncing up and down). Some “jitter” is normal.

Remove the tape to reset the tracking to its preset center.

Note: The tracking buttons only affect tape playback. They have no effect during recording.

Playback on TV (or VCR) with Audio/Video Input Jacks

To connect your camcorder to a TV monitor (or VCR) with audio/video in jacks, you need an optional audio/video cable such as VH83 *shown on page 53*. If your TV is already connected to a VCR, attach the camcorder to the VCR and watch what the camcorder is recording or playing on the TV.

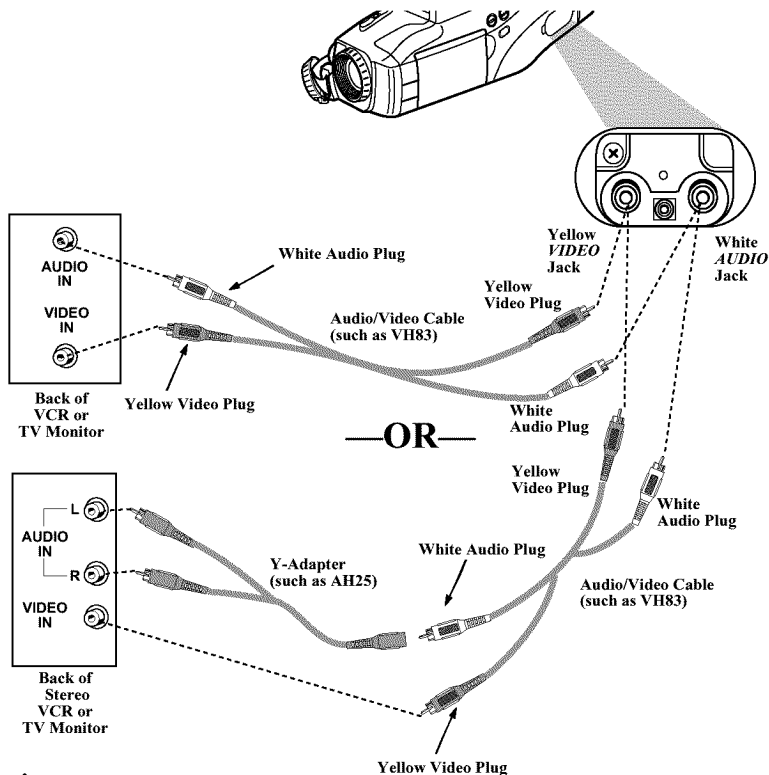

Installation

1. Attach the white plug on one end of the audio/video cable to the *AUDIO IN* jack on the TV (or VCR).

Notes: If your cable does not have white and yellow plugs, be sure to attach the same color to the audio jacks.

If your TV (or VCR) has stereo *AUDIO IN* jacks, attach the plug to the one labeled *MONO*. If one is not labeled *MONO*, you might need a Y-adapter, such as AH25, *shown on page 53* to hear both channels.

2. Attach the yellow plug to the *VIDEO IN* jack on the TV (or VCR).
3. Attach the white plug on the other end of the audio/video cable to the *AUDIO* jack (located under the small cover) on the side of the camcorder.
4. Attach the yellow plug to the yellow *VIDEO* jack on the camcorder.

Playback

Playback Operation and How to Copy Tapes on the VCR

1. A. Camcorder connected directly to TV: Turn on the TV and tune it to the video input channel.
- B. Camcorder connected to VCR that is already connected to TV: Turn on VCR and place it in the “line” or “camera mode”. (If your VCR does not have a “line” or “camera mode”, consult the VCR owner’s manual.) Operate the TV as you normally do to see the signal coming from the VCR.
2. Press and hold the small red button on the *CAMERA/OFF/VCR* switch while you set it to *VCR*.
Note: The camcorder can only play back tapes recorded in the SP speed.
3. Press *PLAY*.
 - During playback, use the playback features on pages 44-45.
 - Turn the volume control on the monitor down all the way to prevent picture distortion.
4. To copy what the camcorder is playing, place a blank cassette in the VCR, and press the VCR’s *RECORD* button.
Note: Make sure the memory-stop feature is turned off (press *DISPLAY*) or the camcorder will enter play-pause when the counter reaches 0000M.
5. Press *STOP/EJECT* when you are finished.

Viewing What the Camcorder is Seeing (or Recording)

1. A. Camcorder connected directly to TV: Turn on the TV, and tune it to the video input channel.
- B. Camcorder connected to VCR that is already connected to TV: Turn on VCR and place it in the “line” or “camera mode”. (If your VCR does not have a “line” or “camera mode”, consult the VCR owner’s manual.) Operate the TV as you normally do to see the signal coming from the VCR.
2. Press and hold the small button on the *CAMERA/OFF/VCR* switch while you set it to *CAMERA*.
Note: Turn the TV’s volume down to prevent a high-pitched squeal caused by feedback.
3. Press the *REC/PAUSE* button to begin recording. You can watch what the camcorder is seeing (or recording) on the TV screen.

Caution: The unauthorized recording of copyrighted material may infringe the rights of others.

Playback

Playback on TV Without Audio/Video Inputs

To connect your camcorder to a TV without audio/video inputs, you need an optional CRF95 RF output adapter and an optional coaxial RF cable, such as VH82 or VH90 shown on page 52. If your TV has *AUDIO* and *VIDEO IN* jacks (or is connected to a VCR), refer to pages 46-47.

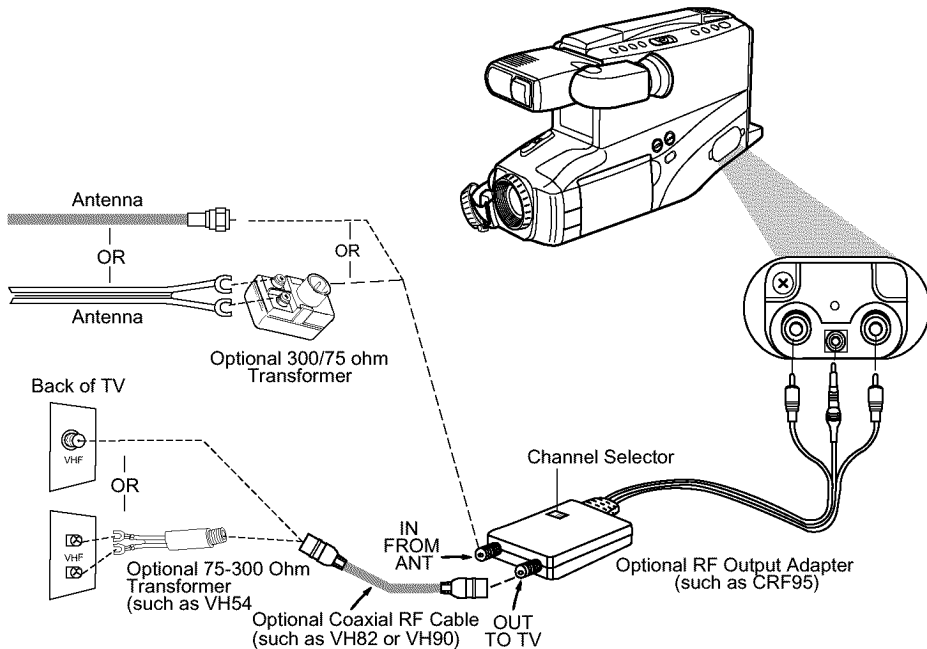

Installation

1. Disconnect the VHF antenna from your TV. Connect the antenna to the *IN FROM ANT* connector on the RF output adapter if you are going to leave the adapter connected to the TV.

Note: If your VHF antenna is the flat twin-lead type attached by two screws, you need an optional 300/75 ohm transformer.

2. Attach one end of the optional coaxial RF cable to the *OUT TO TV* connector on the adapter, and attach the other end to the VHF input on your TV as shown.

Note: If your TV has 300 ohm screw terminals, you need a 75/300 ohm transformer, such as VH54, shown on page 53.

3. Attach the RF output adapter's yellow plug to the *VIDEO* jack, the small plug to the *RF DC OUT* jack, and the white plug to the *AUDIO* jack located under the small cover on the side of the camcorder.

Playback

Playback Operation

1. Set the *CH3/CH4* switch on the RF output adapter to channel *CH3* or *CH4*.
2. Turn on the TV, and tune it to the same channel you selected with the RF output adapter's *CH3/CH4* switch.
3. Press and hold the small red button on the *CAMERA/OFF/VCR* switch while you set it to *VCR*.
4. Press *PLAY* on the camcorder.
 - Turn the volume control on the monitor down all the way to prevent picture distortion.
 - During playback, use the playback features *described on pages 44-45*.
5. Press *STOP/EJECT* on the camcorder when you are finished.

Viewing What the Camcorder Is Recording

1. Turn on the TV and tune it to channel 3 or 4. Turn the TV's volume down to prevent a high-pitched squeal caused by feedback.
2. Set the *CH3/CH4* switch on the RF output adapter to the same channel you selected on the TV.
3. Press and hold the small red button on the *CAMERA/OFF/VCR* switch while you set it to *CAMERA*.
4. Press the *REC/PAUSE* button to begin recording. You can watch what the camcorder is seeing (or recording) on the TV screen.

Normal TV Viewing

For normal TV viewing, leave the RF output adapter hooked up to the TV. Disconnect the adapter's plug from the camcorder or turn the camcorder's power off.

Note to Cable TV Installer

This reminder is provided to call your attention to Article 820-40 of the National Electrical Code (Section 54 of Canadian Electrical Code, Part I), that provides guidelines for proper grounding and, in particular, specifies that the cable ground shall be connected to the grounding system of the building as close to the point of cable entry as practical.

Optional Accessories

We invite you to take a look at some great ideas for sparking creativity and adding to the fun of using your VHS camcorder. The following pages have a selection of accessories to help make your memorable moments look and sound even better.

These accessories are designed to make the process of recording and watching your videos more enjoyable.

To order accessories, contact your local Dealer.

If a dealer is not nearby, all accessories are available through toll-free ordering or by using the order form *on page 55*.

AC202 Soft Carrying Case

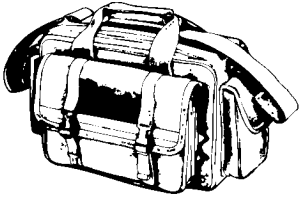

This case provides protection and utility for full size camcorders and most accessories. It is constructed of rugged nylon fabric for years of reliable service.

Three outside pockets provide ample accessory storage with mesh-covered lens filter compartment and built-in holders for memo pads, pens, and other accessories. The hand grip and adjustable shoulder strap allow for convenient, comfortable transportation of the camcorder.

DCC096 DC Car Cord Adapter

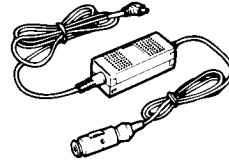

Do not use any other car cord with this camcorder.

This car cord adapter enables you to operate your camcorder from your car, truck, or RV by plugging the car cord directly into the vehicle's cigarette lighter socket. The DCC096 is designed specifically to convert power from a 12-volt battery to a 9.6-volt output.

Optional Accessories

EP096FS and EP096FL Rechargeable Batteries

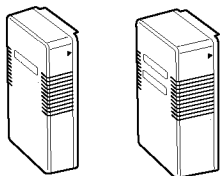

These rechargeable lead-acid batteries are designed specifically for long life. The EP096FS is a 1-hour battery. The EP096FL powers your camcorder twice as long as the EP096FS (depending on how much you turn the camcorder on and off and use zoom and pause). Both can be recharged with the AC adapter/charger that came with your camcorder.

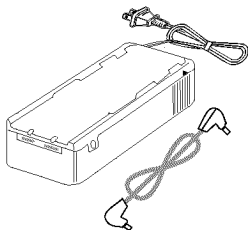

CPS014 AC Battery Charger

The CPS014 battery charger plugs directly into an AC outlet and charges the EP096FS and EP096FL camcorder batteries. Because the CPS014 operates on 100-240 Volts, 50/60 Hz, it can be used virtually anywhere in the world. A plug adapter might be required in some countries.

All specifications and descriptions of accessories are subject to change without notice.

Using the Optional AC093 Tripod

Mounting the camcorder on a tripod, such as AC093, keeps the camcorder steady and produce excellent video results.

This tripod's fluid-effect head provides smooth camera pan and tilt. The quick-release mount makes it easy to attach or remove the camcorder. The grooved, tubular 3-section leg design folds down to 24" when not in use. Rubber feet allow for sure footing and built-in retractable leg spikes eliminate the need for removing the feet.

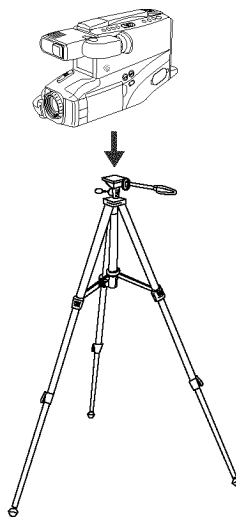

Cautions: Before using a tripod, make sure it is stable enough to hold the camcorder without falling over. Do not transport the camcorder attached to the tripod.

When attaching your camcorder to a tripod, be careful not to force the tripod screw into the camcorder's tripod mounting hole.

The tripod screw should not protrude into the camcorder more than approximately three-eighth (3/8) inch. Forcing the screw could damage the mounting hole on the bottom of the camcorder.

CRF95 RF Output Adapter

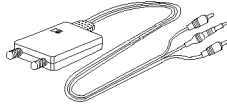

This RF output adapter is used with a coaxial RF cable, such as VH82 or VH90, to connect your camcorder to a standard TV (one without audio/video inputs) for playback. If your antenna cable is the flat twin-lead type attached by two screws, you need a 300-to-75 ohm transformer. If your TV has 300 ohm antenna screw terminals, you need an optional 75-to-300 ohm transformer such as VH54.

Coaxial RF Cables

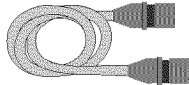

VH82 (6-ft)

VH90 (12-ft)

These RF cables are used with the RF output adapter to connect your camcorder to a standard TV (one without audio/video input jacks) for playback. If your TV has 300 ohm antenna screw terminals, you need an optional 75-to-300 ohm transformer such as VH54. If your antenna cable is the flat twin-lead type attached by two screws, you need an optional 300-to-75 ohm transformer.

All specifications and descriptions of accessories are subject to change without notice.

VH54 Cable Transformer

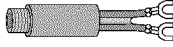

This 75-to-300 ohm transformer is used to connect a standard 75-ohm antenna cable (such as VH82 or VH90) to the 300 ohm screw terminals on a TV.

VH83 Audio/Video Cable

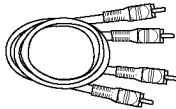

This six foot audio/video cable can be used to connect the camcorder to a TV monitor or VCR for tape playback or copying tapes.

AH25 Y-Adapter



This Y-adapter allows you to connect your camcorder's mono audio cable to a stereo TV or VCR.

Optional Accessories

Removing the Lens Hood

Remove the lens hood so you can attach optional accessories, such as wide-angle lens, lens extenders, or lens filter kits.

Attaching an Accessory Lens

1. Attach the lens cap over the lens hood.

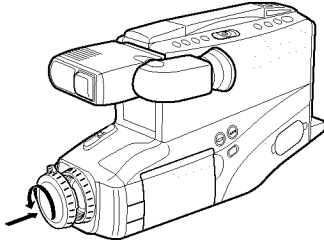

2. To remove the lens cap and hood, turn them counterclockwise with the palm of your hand.

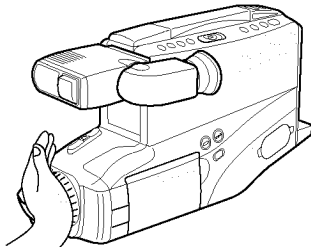

3. Turn the accessory lens clockwise into the camcorder's lens. Make sure the lens is tightened firmly, but do not over tighten.

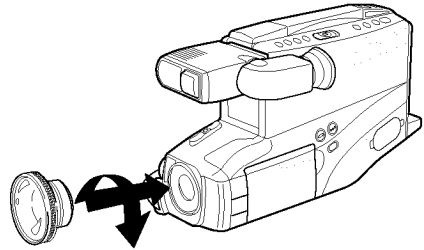

Caution: Do not grasp the end of the lens hood.

All specifications and descriptions of accessories are subject to change without notice.

Accessory Order Form

Order Form for Camcorder Model CC4352				
Description	Part No.	Price	Qty.	Total
Deluxe Tripod	AC093	\$ 59.95		
Soft Camcorder Case	AC202	\$ 49.95		
Y-Adapter	AH25	\$ 2.95		
AC Adapter/Charger (100-240V)	CPS014	\$219.95		
RF Output Adapter	CRF95	\$ 69.95		
Car Cord Adapter	DCC096	\$ 49.95		
Rechargeable Battery (Extended)	EP096FL	\$ 79.95		
Rechargeable Battery (Standard)	EP096FS	\$ 69.95		
75-300 Cable Transformer	VH54	\$ 2.95		
Coaxial RF-Cable	VH82	\$ 6.95		
Audio/Video Cable	VH83	\$ 5.95		
Coaxial RF-Cable	VH90	\$ 7.95		
Shoulder Strap	241305	\$ 12.95		
AC Adapter/Charger (Supplied) and DC Cable	241044 233328	\$169.95 \$ 13.65		

Total Merchandise \$ _____

Sales Tax \$ _____

We are required by law to collect the appropriate sales tax for each individual state, county, and locality to which the merchandise is being sent.

Shipping and Handling \$ 5.00

Total Amount Enclosed \$ _____

Use VISA, MasterCard, or Discover.
Money order or check must be in U.S. currency only. No COD or cash.
Prices are subject to change without notice.

Detach Here

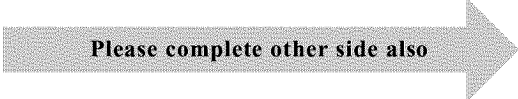

Accessory Order Form

Charge your order on your VISA, MasterCard,
or Discover Card by filling in below

USE YOUR CREDIT CARD

IMPORTANT: Copy complete account number from your VISA card

Expiration date:



IMPORTANT: Copy complete account number from your MasterCard

Copy Number above your name on MasterCard Expiration date:



IMPORTANT: Copy complete account number from your Discover Card

Expiration date:



AUTHORIZED SIGNATURE

Prices are subject to change without notice.

Print or type your name and
address clearly.



A complete and correct order will
save you days of waiting.

Name: _____
Street: _____
_____ Apt: _____
City: _____
State: _____ Zip: _____

Please make sure that both sides of this form have been filled out completely.

- Allow 4 weeks for delivery.
- All accessories are subject to availability.

Detach Here

Accessory Order Form

To order accessories, contact your local Dealer.

If a dealer is not nearby, you can also follow the directions below to order by telephone or direct-by-mail.

United States and Canada Orders

To place your order by phone, have your Visa, MasterCard, or Discover card ready and call the toll-free number listed below between 8 AM and 10 PM (EST) Monday through Friday or between 9AM and 5PM (EST) Saturday.

Use this number only to place an order for accessory items listed on this order form.

1-800-338-0376

To place your order by mail, detach and mail the completed order form with credit card information, money order, or check in U.S. currency (made payable to Thomson Consumer Electronics, Inc.) to the following address:

Video Accessories
PO Box 8419
Ronks, PA 17573

Trouble Checks

If you're having trouble with your camcorder, you probably can correct the problem yourself. Before you take your camcorder to an Authorized RCA Camcorder Service Center or call a service person, use the chart below. Find the problem and try the adjustment(s) that is listed to the right.

If service should be necessary, read your warranty to find out what is covered and how to get service.

Trouble	Checks and Adjustments
No power	<ul style="list-style-type: none"> • Set the <i>CAMERA/OFF/VCR</i> switch to <i>CAMERA</i> or <i>VCR</i> to turn on the camcorder. • If using battery, it may need to be recharged. • If using AC adapter/charger, make sure it is plugged into a working outlet.
Won't record or play back	<ul style="list-style-type: none"> • If using AC adapter/charger, make sure it is plugged into a working outlet. • Make sure <i>CAMERA/OFF/VCR</i> switch is set to correct position for desired operation. • There might not be a cassette in the camcorder. • Try ejecting and reinserting the cassette. • The cassette tape might be broken, try another cassette. • You might have reached the end of the cassette, try rewinding it. • Moisture condensation might cause the tape to stick to the headwheel and damage the headwheel or tape. Give the camcorder 2 or 3 hours to reach a stable temperature before reinserting a cassette.
Won't play back	<ul style="list-style-type: none"> • <i>CAMERA/OFF/VCR</i> switch must be set to <i>VCR</i>.
Won't record	<ul style="list-style-type: none"> • Safety tab removed. <i>See page 18.</i> • <i>CAMERA/OFF/VCR</i> switch must be set to <i>CAMERA</i>.
No picture	<ul style="list-style-type: none"> • Remove lens cap.
Camcorder turns off	<ul style="list-style-type: none"> • Set the <i>CAMERA/OFF/VCR</i> switch to <i>OFF</i> and then to <i>CAMERA</i> or <i>VCR</i> to turn back on. If camcorder is left in record-pause or play-pause for several minutes, it turns off to prevent tape wear.

Trouble Checks

Trouble	Checks and Adjustments
Sound is too low or distorted	<ul style="list-style-type: none"> • Subject was too far from camcorder.
Tape stops during rewind or fast forward or will not operate during rewind or fast forward	<ul style="list-style-type: none"> • Whenever the tape counter appears, the camcorder will stop rewinding (or fast forwarding) when counter reads <i>0000M</i>. Press <i>REW/REVIEW</i> or <i>F.FWD</i> again to continue rewinding or fast forwarding, or press <i>DISPLAY</i> to remove the tape counter. • Make sure titler graphics do not appear in viewfinder or on LCD monitor. Press <i>TITLER</i> button to remove.
Camcorder remains in play-pause mode	<ul style="list-style-type: none"> • Press <i>REC/PAUSE</i> to return to normal playback.
Poor auto-focus operation	<ul style="list-style-type: none"> • Lens is smudged and image appears unfocused. • Eyepiece focus control is misadjusted.
Viewfinder displays are out of focus	<ul style="list-style-type: none"> • Eyepiece focus control is misadjusted. <i>See page 23.</i> • The small <i>BRIGHT</i> and <i>FOCUS</i> controls on the side of the viewfinder control the brightness and focus of the viewfinder. These controls have been set at the factory and should require no adjustment. If the controls ever require adjustment, carefully use a plastic screwdriver. Make the adjustments with caution to prevent damaging the miniature controls.
Picture quality is poor during playback	<ul style="list-style-type: none"> • Tape was recorded on a different camcorder or VCR. If the picture contains black-and-white streaks, press one of the tracking buttons to correct it. <i>See page 45.</i> • Camcorder only has one speed (SP). If the tape was recorded at a different speed, it cannot be played back on this camcorder.
Picture recorded with a special fade or digital effect (such as negative, 16X9, mosaic, or mirror)	<ul style="list-style-type: none"> • A fade or fade wipe mode has been selected. Turn off the fade effect by pressing <i>FADE</i>. <i>See pages 34-35.</i> • A digital recording effect has been selected. Turn off the digital effects by pressing <i>DIGITAL EFFECTS</i>. <i>See pages 30-33.</i>

Trouble Checks

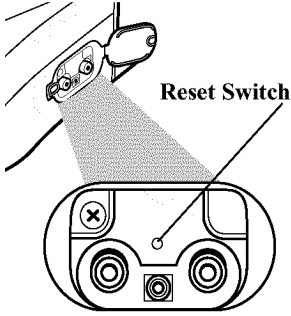
Trouble	Checks and Adjustments
<p>Date and/or time or title were recorded on tape</p>	<ul style="list-style-type: none"> • Displays are recorded on tape whenever they appear in the viewfinder or on the LCD monitor. Remove them from the viewfinder or LCD monitor when recording. <i>See pages 20-21.</i> • When ⌚ <i>DATE</i> or ⌚ <i>TITLE</i> is selected, the display is automatically recorded when you begin recording or change the cassette. <i>See pages 20-21.</i> • Title is recorded whenever it appears in the viewfinder or on the LCD Monitor. Press the <i>TITLER</i> button to remove the title from the viewfinder or LCD monitor. <i>See pages 38-40.</i>
<p>Date and/or time are incorrect</p>	<ul style="list-style-type: none"> • Date or time may need to be set. <i>See page 20.</i> • Clock lithium cell battery may need recharging. <i>See page 21.</i>
<p>Viewfinder turns off and on</p>	<ul style="list-style-type: none"> • LCD monitor is open at least 45°. Viewfinder automatically turns off. Monitor closed, viewfinder turns on. • During recording, viewfinder turns on when monitor rotated around to face the subject. • During playback, viewfinder turns off when monitor rotated around and placed against camcorder.
<p>Camcorder does not turn on and/or function buttons will not operate</p>	<ul style="list-style-type: none"> • Remove the power source. After one minute press the reset switch gently using a nonmetallic pointed item, such as a toothpick, until you feel a click. This resets the camcorder to the factory settings and erases the date, time, and custom settings. Wait for at least one minute after resetting the camcorder to attach a power supply. 

Trouble Checks

Trouble	Checks and Adjustments
No or low sound during monitor playback	<ul style="list-style-type: none">• Adjust the volume control on the side of the monitor.• To hear sound during camcorder playback, use the monitor. There is no sound during viewfinder playback.
Black bars on top and bottom of picture.	<ul style="list-style-type: none">• <i>16X9</i> feature selected. <i>See page 31.</i>
Bright, crystal-shaped spots appear in viewfinder or on LCD monitor	<ul style="list-style-type: none">• Sunlight is directly entering the lens.
Colored bright spots appear on LCD monitor	<ul style="list-style-type: none">• Black spots or bright spots of light (red, green, or blue) may appear on the LCD monitor. These spots are not recorded on the tape and are not due to a defect in the unit.
Back of LCD monitor is hot	<ul style="list-style-type: none">• The light that illuminates the LCD monitor gets hot. To cool it down, close the LCD monitor and turn off the camcorder.
Rechargeable battery runs down sooner than expected	<ul style="list-style-type: none">• Lead-acid batteries must be kept charged. Charge your battery before and after every use and at least every six months.• Battery run times are measured when the camcorder is recording continuously. To check your battery; charge it completely, aim the camcorder at a clock, and record the clock. When the camcorder stops recording, play the last part of the tape and check the time on the clock. A one-hour battery should give you about 60 minutes of recording time. In practical use, a fully charged battery might not record for 60 minutes because the battery uses power when you pause the recording and uses extra power when you zoom.

Care and Maintenance

Cleaning the Camcorder

To clean the camcorder's exterior, remove any power source connected to the camcorder and gently wipe it with a clean soft cloth.

Caution: Use of strong cleaning products, such as those containing alcohol or benzine, might damage the camcorder.

Cleaning the Lens

To clean the camcorder's lens, blow it with a blower brush, and then gently wipe the lens with cleaning tissue and commercially prepared cleaning solution designed for use on camera lens. Improper cleaning might scratch the lens.

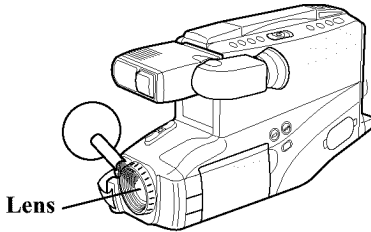

Caution: Do not touch the lens with your fingers. The oil from your skin can damage the lens.

Clean the LCD Monitor

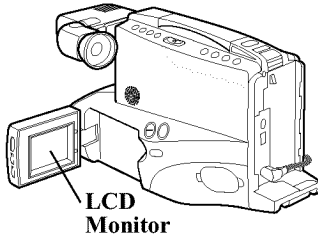

To clean the camcorder's LCD monitor, use a clean, soft cloth to carefully wipe the monitor. Improper cleaning may scratch the monitor.

Caution: Do not touch the monitor with your fingers. The oil from your skin might damage the monitor.

Cleaning the Viewfinder

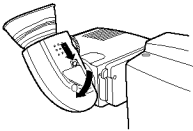

Caution: Do not force the cover to open completely. This might damage the cover.

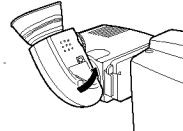
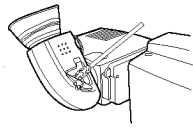

1. Depress tab to open small cover.
2. Gently use a cotton swab and clean the mirror inside the viewfinder.
3. Gently close cover until tab snaps in place.

Care and Maintenance

Proper Care and Storage

- Keep dust and grit from entering the camcorder's cassette door. Dust and grit are abrasive and cause excessive wear to both the camcorder's recording/playback heads and cassettes.
- Always place the lens cap back on the camcorder when it is not in use.
- Before handling your camcorder, make sure your hands and face are free from any chemical products such as suntan lotion, as it might damage the finish.
- The camcorder might be damaged by improper storage or handling. Do not subject the camcorder to swinging, shaking, or dropping.
- Do not store the camcorder in temperatures below -22°F (-30°C) or above 149°F (65°C).
- When the camcorder is not in use, always remove the cassette and AC adapter/charger or battery.
- Retain the original carton for future storage or shipping purposes.

Things to Avoid

- Do not attempt to disassemble your camcorder. There are no user-serviceable parts inside.
- Avoid operating your camcorder immediately after moving it from a cold location to a warm location. Give the camcorder 2 to 3 hours to reach a stable temperature before inserting a cassette. When the camcorder is moved from cold to warm, condensation might cause the tape to stick to the headwheel and damage the headwheel or tape.
- Do not aim your camcorder at the sun or other bright objects.
- Do not leave your camcorder in direct sunlight for extended periods of time. The resulting heat buildup might permanently damage the camcorder's internal parts.
- Do not operate the camcorder in extremely humid environments.
- Do not operate the camcorder near the ocean as salt water or salt water spray might damage the internal parts of the camcorder.
- Do not operate the camcorder for extended periods in temperatures below 40°F (4°C) or above 95°F (35°C).
- Do not expose the camcorder or adapter/charger to rain or moisture. If any component becomes wet, turn off the power and take the unit to an Authorized RCA Camcorder Service Center.
- Do not use an adapter/charger or batteries other than the ones specified for the camcorder. Use of the wrong accessories might cause damage to the camcorder.
- Do not hold the camcorder by the viewfinder or LCD extension as this could damage them.

Specifications

General

Power requirement: 9.6VDC

Power consumption:

LCD monitor on: 9 watts

Viewfinder on: 7.5 watts

Weight: 4.7 lbs. (2.15kg)

Dimensions – Including Viewfinder:

4³/₄" (W) x 8³/₈" (H) x 13¹/₈" (D)

121 (W) x 213 (H) x 334 (D) mm

Video Recorder Section

Format: VHS

Record/playback system:

Two video record/playback heads

Video signal: EIA standard

NTSC color

Viewfinder

0.5" black-and-white electronic viewfinder

LCD Monitor

3" diagonally measured

LCD/TFT active matrix system

Camera Section

Scanning: 525 lines/60 fields/30 frames

Image Sensor: 1/4" CCD Imager

Lens: F1.4

16:1 (4-64 mm) power zoom lens

Diameter: 46 mm

Tripod Mount

One 1/4" x 10 threaded hole

AC Adapter/Charger

Power requirement: 120 V,
50/60 Hz.

Power consumption: 24 watts

Weight: .85 lbs. (390g)

Dimensions:

6"(W) x 1.7"(H) x 2.7"(D)

152 (W) x 43 (H) x 69 (D) mm

Information to User

This equipment has been tested and found to comply with the limits for a Class B digital device pursuant to Part 15 of the FCC Rules. These limits are designed to provide reasonable protection against harmful interference in a residential installation. This equipment generates, uses, and can radiate radio frequency energy and, if not installed and used in accordance with the instructions, may cause harmful interference to radio communications. However, there is no guarantee that interference will not occur in a particular installation. If this equipment does cause harmful interference to radio or television reception, which can be determined by turning the equipment off and on, the user is encouraged to try to correct the interference by one or more of the following measures:

- Reorient or relocate the receiving antenna.

- Increase the separation between the equipment and receiver.
- Connect the equipment into an outlet on a circuit different from that to which the receiver is connected.
- Consult the dealer or an experienced radio/TV technician for help.

Alterations or modifications carried out without appropriate authorization may invalidate the user's FCC right to operate the equipment.

This Class B digital apparatus meets all requirements of the Canadian Interference — Causing Equipment Regulations.

Cet appareil numérique de la classe B respecte toutes les exigences du Règlement sur le matériel brouilleur du Canada.

Customer Assistance and Service

You can reach Thomson at the following number:

800-283-6503

(Toll free inside U.S.A.)

Our toll-free Camcorder number operates from 8 a.m. to 5 p.m., CST Monday – Friday for U.S. customers only

Thomson provides a toll-free telephone number to help you with any problems you may encounter with your camcorder. Many can be diagnosed over the phone, and if necessary, repair or replacement will be arranged. Please have your camcorder model/serial number and date of purchase ready when you call. If your unit is out of warranty, we will quote the cost of a repair or replacement unit to you.

Returning equipment to Thomson for repair or exchange

If we are unable to resolve your problem over the phone, we will gladly service your unit or exchange it for a new or, at our option, refurbished camcorder. Refer to the limited warranty on the next page to learn about your specific rights and responsibilities.

Always consult Thomson and get a Return Authorization number before returning anything! Obtain a Return Authorization (RA) number from the telephone representative before returning your equipment to avoid delays, accounting errors, or even loss of your unit.

Important information to customers who ship defective equipment to Thomson Consumer Electronics

The Thomson representative who authorized the return of your equipment will give you an RA number over the phone. They will also provide you with instructions on where and how to return your Camcorder. Write the number in large, clear characters on the outside of the box. To avoid confusion and misunderstandings, shipments without an RA number clearly visible on the outside of the box will be returned to you at your expense.

Include a brief note describing the problem and any conversations about the problem you have had with Thomson personnel.

Include your name, address and model/serial number of your Camcorder. These numbers

are located on the bottom of your unit.

If your Camcorder is within the warranty period, please provide a copy of the bill of sale to verify purchase date. Use the original box and packing material to protect the equipment from damage in shipment.

For your protection, insure all shipments for full replacement value and use a reliable shipper. Thomson assumes no responsibility for warranty shipments from the customer to the factory if not shipped in the manner prescribed by Thomson.

Limited Warranty

What your warranty covers:

- Any defect in materials or workmanship.

For how long after your purchase:

- 90 days for labor charges.
- One year for parts.

The warranty period for rental units begins with the first rental or 45 days from date of shipment to the rental firm, whichever comes first.

What we will do:

During the initial 90 days

- Exchange your camcorder with a new or refurbished unit, or repair your camcorder. The option will be ours. There will be no cost to you.

After the 90 days and within one year

- Exchange your camcorder with a new or refurbished unit, or repair your camcorder. The option will be ours. Parts will be provided at no charge, but you will be responsible for the cost of labor required for the repair.

How you get service:

- Call 1-800-283-6503 and have your unit's date of purchase and model/serial number ready. The model/serial number information is on the bottom of your camcorder.
- A representative will troubleshoot your problem over the phone. If the representative determines that you should receive a replacement unit, you will be provided with a Return Authorization (RA) number and the location of a nearby exchange point if one exists. No returns will be accepted without the RA number.

To receive a replacement Camcorder before you return yours:

Option 1

1. Provide your Discover, MasterCard, or

Visa account number and expiration date to our phone representative. This is for security purposes. If we receive your unit, excluding all accessories, within 14 days from the date you were provided the RA number, only items not covered by warranty will be charged to your account. **IF YOUR UNIT IS NOT RECEIVED WITHIN 14 DAYS, THE SUGGESTED RETAIL VALUE OF THE CAMCORDER WILL BE CHARGED TO YOUR CREDIT CARD.** This amount will be credited if the unit is subsequently received.

2. We will send you a replacement unit.
3. Ship the unit back to us, excluding all accessories, using the replacement unit's carton. Shipping instructions will be included in the carton along with your RA number which will allow you to easily ship the unit back to us. **Make sure you insure your shipment in case of damage or loss.** Include with the shipment:
 - Evidence of purchase date, such as a bill of sale, to verify your unit's warranty eligibility.
 - A brief note describing your camcorder's problem.
 - Your name, address and phone number.

Return transportation, storage, handling, and insurance costs are your sole responsibility. We accept no liability in case of damage or loss.

Option 2

1. We will send a replacement unit to the exchange point.
2. The exchange location will notify you of its arrival.
3. Take your unit, excluding all accessories, and your evidence of purchase date (such as a bill of sale) to the exchange location and you will be provided the new or refurbished unit.
4. If the repairs were covered by your warranty, you will not be billed.

Limited Warranty

To receive a replacement unit after we have received your unit:

1. **Write the RA number on the outside of the carton used to return the unit. Make sure you insure your shipment in case of damage or loss.**
2. Carefully pack the unit, excluding all accessories, using the original box and packing material if possible.
3. Include with the shipment:
 - Evidence of purchase date, such as a bill of sale, to verify your unit's warranty eligibility.
 - A brief note describing your camcorder problem.
 - Your name, address and phone number.

Return transportation, storage, handling, and insurance costs are your responsibility. We accept no liability in case of damage or loss.

4. The representative will advise the address to mail a cashier's check or money order for payment if there are any out of warranty labor or parts charges and you elect not to use your credit card.
5. Upon receipt of your product, a new or refurbished unit will be shipped to you next business day delivery in the continental U.S.A.

To have your Camcorder repaired by an Authorized RCA Camcorder Service Center:

- Check with your dealer or call 1-800-336-1900 for the Authorized RCA Camcorder Service Center nearest you.
- Take your unit to the Authorized RCA Camcorder Service Center of your choice.
- Show the Authorized RCA Camcorder Service Center representative evidence of purchase date, such as a bill of sale.
- Pick up your camcorder when repairs are complete.

What your warranty does not cover:

- Adjustment of customer controls.
- Damage from misuse or neglect.
- A unit that has been modified or incorporated into other products or is used for institutional or other commercial purposes.
- Batteries for remote control and clock.
- Cleaning of video/audio heads.
- Camcorders purchased or serviced outside the U.S.A.
- Return transportation, storage and handling costs of your unit, including insurance for loss or damage.
- Acts of God, such as but not limited to lightning damage.

Product Registration:

- Please complete and mail the Product Registration Card packed with your camcorder. It will make it easier to contact you should it ever be necessary. The return of the card is not required for warranty coverage.

How State Law relates to warranty:

- This warranty gives you specific legal rights and you also may have other rights that vary from state to state.

If you purchased your camcorder outside the United States:

- This warranty does not apply. Contact your dealer for warranty information.

A

- Accessories
 - included 3
 - optional 50
 - order form 55
- Adapter/charger
 - accessory 3
 - charging battery 13
 - using 4, 12
- AE focus indicators 24, 27
- Assistance 1, 3
- Audio/Video (A/V) jacks 9, 46, 48

B

- Battery 3
 - attaching and removing 14
 - care 16
 - charging 13
 - safety precautions 16
 - storage 16
 - using 13
- BATTERY EJECT button 10, 14
- Battery level indicator 15, 24
- Bright control 10, 22, 42, 43
- Built-in speaker 10

C

- Cable TV installer note 49
- Camcorder
 - cleaning 62
 - turn on 5
- Camera edit feature 37

- CAMERA/OFF/VCR switch
 - 5, 9, 14, 15, 17, 20, 21, 26, 36, 37, 38, 39, 40, 42, 43, 44, 47, 49
- Car cord adapter 17
- Care and maintenance
 - cleaning the camcorder viewfinder 62
 - proper care and storage 63
 - things to avoid 63
- Care and storage
 - camcorder 63
 - cassette 19
- Cassette door 10
- Cassette holder 19
- Cassettes
 - inserting/removing 19
 - video 18
- Charging clock battery 21
- Cleaning the camcorder's lens 62
- Cleaning the LCD monitor 62
- Cleaning the viewfinder 62
- Clock battery
 - charging 21
- Copy tapes 47
- Customer Assistance 65

D

- Date and time
 - display 20, 25
 - recording 21
 - setting 20
- DATE/TIME button
 - 9, 20, 21, 25, 40
- DC cable 3, 12, 13, 14, 17

Index

DC IN 9.6V jack 10, 12, 17
Digital Effects
 16X9 feature 31
Digital effects 30
DIGITAL EFFECTS button
 10, 24, 30, 31, 32, 33, 34
Digital effects indicators 24, 30
Digital zooming 32
DISPLAY button
 9, 15, 24, 25, 26, 27, 28,
 29, 30, 31, 32, 33, 36, 47
Displays in LCD monitor 24
Displays in viewfinder 24

E

EDIT-ADV button 9, 38, 39
Editing features
 camera edit 37
 flying erase head 37
 title recording 40
 Titler 38
Electronic indexing 28
Erase protection 18
Eyepiece focus control
 10, 23, 42, 43

F

F FWD (fast forward) button
 9, 20, 36, 37, 38, 44
FADE button 10, 34, 35
Fade indicators 24, 34
Fast-forwarding indicator 25
FOCUS control 10

H

Handstrap 4, 10
Head cleaning 18

I

Important safety information 2
INDEX indicator 25, 28
Indicators
 16X9 24, 31
 AE focus 24, 27
 battery level 15, 24
 digital effects 24, 30
 fade 24, 34
 fast-forwarding 25
I.ZOOM 29
INDEX 25, 28
MIRROR 24, 33
MOSAIC 24, 33
NEGPOS 24, 32
NO TAPE 25
 pause 25
REC 7, 25
 record-pause 7
 rewind 25
 status 25
TAPE 25
 tape counter 25, 36
TAPE END 25
 tape remaining 25, 27
ZM:2 24, 32
ZOOM 24, 25, 29
 zoom level 25, 29

Index

Information to user 64
Insert and remove cassettes 19
INST ZOOM button 10, 29
Instant zooming 29

L

LCD monitor 6, 10
 displays 24
 using to record 22
Lens 9
Lens cap 4
Lens cover 8
Lens hood 9
 removing 54
Letterbox recording 31

M

Macro focus 27
Memory-stop feature 36
MENU button 35
Microphone 9, 26
MIRROR indicator 24, 33
Mirror mode 33
MOSAIC indicator 24, 33
Mosaic mode 33

N

NEG POS indicator 24, 32
Negative mode 32
NO TAPE indicator 25

O

OPEN button 6, 10, 22, 42, 43
Operating Controls
 Plus (+) and Minus (-) buttons
 9, 38
Operating controls 9
Optional accessories 50

P

PLAY button
 8, 9, 37, 42, 43, 47, 49
Playback
 First 8
Playback features
 stop-action pause 44
 tape counter 36
 tape positioning 44
 tracking 45
 visual searching 44
Playback on a TV without A/V inputs
 48
Playback on TV/VCR with A/V
 inputs 46
Playback speed 18
Playback using LCD monitor 42
Playback using viewfinder 42
Power your camcorder
 adapter/charger 12
 battery 13
 car cord adapter 17
Problem solving 58

Q

Quick review feature 26

R

REC indicator 7, 25

REC/PAUSE button

7, 10, 31, 32, 33, 35, 40, 44, 47, 49

Record-pause indicator 7

Recording

16X9 31

16X9 indicator 31

letterbox 31

Recording speed 18

Recording tips 41

Registration 2

RESET button 9, 36

Reset switch 9

REW (rewind) button 8, 9

REW (rewind)/REVIEW button 44

REW(rewind)/REVIEW button

20, 26, 36, 37

REW(rewind)/REVIEW) button 38

Rewind indicator 25

RF DC OUT jack 9, 48

RF output adapter, optional 48

S

Safety precautions

battery 16

Safety tab 18

Searching during playback 44

Shoulder extension pad 6, 10

Shoulder strap 3

attaching 11

attachment rings 10

SP speed 18, 43

Speaker 42

speaker, built-in 10

Specifications 64

Speed

recording and playback 18

Status indicators 25

STOP button 8, 36

Stop-action pause 44

STOP/EJECT button

5, 9, 15, 19, 20, 36, 38, 42,

43, 44, 47, 49

T

Tape

copying 47

inserting 5

Tape counter 25, 36

TAPE END indicator 25

TAPE indicator 25

Tape positioning 44

Tape remaining display 27

Tape warnings 25

Things to avoid 63

Time and date

setting 20

Time and date display 20, 25

recording 21

Index

Tips

- recording 41
- Titler 38, 39, 40
 - chart of characters 38
 - correcting errors 39
 - creating a title 39
 - record while copying a tape 40
 - recording 21
 - recording on a tape 40
- TITLER button 9, 38, 39, 40
- Titler character chart 38
- Tracking 45
- TRACKING buttons 10
- Tracking buttons 45
- Tripod
 - using 51
- Trouble checks 58

V

- VIDEO and AUDIO jacks 9, 46, 48
- Videocassettes 18
- Viewfinder 6, 10, 22, 23
 - 16X9 indicator 24
 - adjust for viewing 23
 - displays 24
 - eyepiece focus control 23
 - playback 42, 43
 - using to record 22
- Visual searching 44
- Volume control 10, 42

W

- Warnings 2, 25

Z

- ZM:2 indicator 24, 32
- ZOOM indicator 29
- Zoom buttons 10, 29
- ZOOM indicator 24, 25, 29
- Zoom level indicator 25, 29
- Zoom lever 34
- Zooming 29
 - digital 32

Note: This equipment has been type tested and found to comply with the limits for a Class B Digital Device in accordance with the specifications in Part 15 of FCC Rules. These rules are designed to provide reasonable protection against radio and television interference in a residential installation. This equipment generates, uses and can radiate radio frequency energy and, if not installed and used in accordance with the instructions, may cause harmful interference to radio communications. However, there is no guarantee that interference will not occur in a particular installation.

If this equipment does cause interference to radio or television reception (which you can determine by turning the equipment off and on), try to correct the interference by one or more of the following measures.

- Reorient or relocate the receiving antenna (that is, the antenna for radio or television that is “receiving” the interference).
- Change the position of the camcorder with respect to the radio or television equipment that is receiving interference.
- Move the camcorder away from equipment receiving interference.
- Plug the adapter/charger into a different wall outlet so the receiver and equipment receiving interference are on different branch circuits.

If these measures do not eliminate interference, please consult your dealer or an experienced radio/television technician for additional suggestions. Also, the Federal Communications Commission has prepared a helpful booklet, “How To Identify and Resolve Radio/TV Interference Problems”. This booklet is available from the U.S. Government Printing Office, Washington, D.C., 20402. Please specify stock number 004-000-00345-4 when ordering copies.

 **THOMSON CONSUMER ELECTRONICS**

**10330 N Meridian Street
Indianapolis, IN 46290**

©1999 Thomson Consumer Electronics, Inc.

Trademark(s)[®] Registered

Marca(s) Registrada(s)

Printed in Japan

TOCOM 15331620

QR31043