

RCA

camcorder user's guide

CC4271

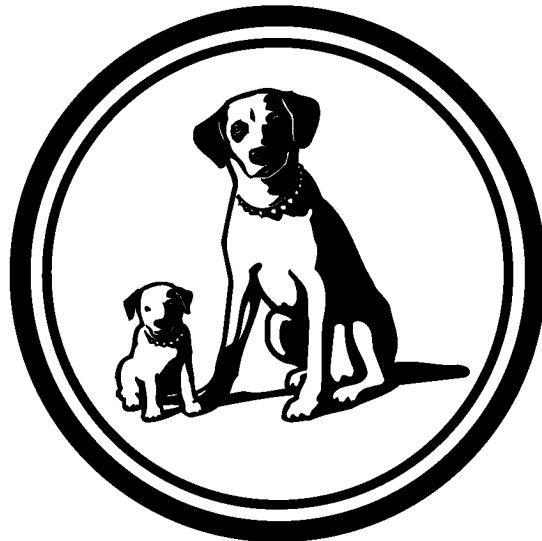

Important Safety Information

Be sure to read all the safety information before you begin to use this product.

WARNING: To reduce the risk of fire or shock hazard, do not expose camcorder or AC adapter/charger to rain or moisture.

CAUTION
RISK OF ELECTRIC SHOCK
DO NOT OPEN



This symbol indicates “dangerous voltage” inside the product that presents a risk of electric shock or personal injury.

ATTENTION
RISQUE DE CHOC ELECTRIQUE
NE PAS OUVRIR



This symbol indicates important instructions accompanying the product.

TO REDUCE THE RISK OF ELECTRIC SHOCK, DO NOT REMOVE THE COVER (OR BACK). NO USER-SERVICEABLE PARTS ARE INSIDE. REFER SERVICING TO QUALIFIED SERVICE PERSONNEL.

Cautions

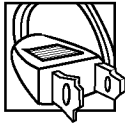

CAUTION: To prevent electric shock, match wide blade of plug to wide slot, fully insert.

ATTENTION: Pour éviter les chocs électriques, introduire la lame la plus large de la fiche dans la borne correspondante de la prise et pousser jusqu'au fond.

To reduce risk of injury, charge only rechargeable batteries recommended by the manufacturer for this camcorder. Other types of batteries may burst causing damage and personal injury.

FCC Regulations state that unauthorized changes or modifications to this equipment may void the user's authority to operate it.

Product Registration

Please fill out the product registration card and return it immediately. Returning this card allows us to contact you if needed.

Keep your sales receipt for proof of purchase to obtain warranty parts and service and attach it here. Record the serial number and model numbers located on the bottom of the camcorder.

Model No: CC4271
Serial No: _____
Purchase Date: _____
Purchased From: _____

Assistance

We want to make sure you enjoy your new camcorder. If you have any questions, call:

Camcorder Exchange Warranty.....800-283-6503 (pages 60-61)

Customer Service.....800-336-1900 (page 59)

Accessories..... 800-338-0376 (pages 45-51)

Table of Contents

Safety Information	i	Attach the Shoulder Strap	11
First Time Operation		Built-In Color Enhancement	
• Assistance	3	Light	12-13
• Unpack the Camcorder and Accessories	3	Power Your Camcorder	
• Attach the Adapter/Charger	4	• Use the Adapter/Charger to Power Your Camcorder	14
• Adjust the Handstrap, Remove Lens Cap, and Attach It to the Handstrap	4	• Use the Battery to Power Your Camcorder	15-18
• Insert a Tape	5	• Charge the Battery	15
• Turn on the Camcorder	5	• Attach the Battery	16
• Adjust the Viewfinder and Eyepiece Focus Control	6	• Battery Level Indicator	17
• Set <i>LIGHT AUTO/OFF/ON</i> Switch to <i>AUTO</i>	7	• Battery Care	18
• Start and Stop Recording	7	• Battery Storage	18
• Play Back What you Have Recorded	8	• Battery Safety Precautions	18
• Set the <i>CAMERA/OFF/VCR</i> Switch to <i>OFF</i>	8	• Use the Optional DCC096 Car Cord Adapter	19
• Replace the Lens Cap	8	Videocassettes	
• Review Camcorder's Operating Controls	9-10	• Erase Protection	20
		• Record and Playback Speed and Times	20
		• Insert and Remove Cassettes	21
		• Cassette Care and Storage	21

(continued on next page)

Table of Contents

Date and Time Display

- Set the Time and Date 22
- Record Time and Date, *AUTO*
Date, Auto *TITLE*, or Date 23
- Charge the Built-in Clock
Battery 23

Recording

- Use the Viewfinder 24-25
- Viewfinder Displays 26-27
- *DISPLAY* Button 28
- Microphone 28
- Auto Shot™ Feature 28
- Camera Edit 29
- Quick Review Feature 29
- Auto Focus 29
- Macro Focus 29
- Tape-Remaining Display 30
- Electronic Indexing 30
- Zooming 31
- Fade In and Out of Scenes 32
- Steady Pix™ Feature 33
- Tape Counter 34
- Titler 35-37

Playback

- Viewfinder Playback and Playback
Features 38-39
 - Play Back a Tape in the
Viewfinder 38-39
- Playback Features 39
 - Tape Positioning 39
 - Stop-Action Pause 39
 - Visual Searching 39
 - Tracking 39

- Playback on TV (or VCR) with
Audio/Video Inputs 40-41
- Playback on TV Without
Audio/Video Inputs 42-43

Travel and Recording

Tips 44

Optional Accessories 45-51

- Optional Accessories 45-47
- Remove Lens Hood to
Attach Accessory Lens 48
- Accessory Order Form 49-51

Trouble Checks 52-54

Information to User 55

Care and Maintenance

- Clean the Camcorder 56
- Clean the Camcorder's Lens 56
- Clean the Camcorder's
Viewfinder 56
- Proper Care and Storage 57
- Things to Avoid 57

Specifications 58

Customer Assistance 59

Limited Warranty 60-61

Index 62-65

First-Time Operation

This section describes the basic steps necessary to set up your camcorder to record. Refer to the other sections for detailed operation and feature options.

Assistance

The toll-free numbers are available to help you with any problem you may encounter.

Camcorder Exchange Warranty.....800-283-6503

Customer Service..... 800-336-1900

Accessories..... 800-338-0376

1. Unpack the camcorder and accessories.

- Save the packing materials and box in case you ever need to ship or store your camcorder.
- The items shown below are packed with your camcorder. If any are missing or appear damaged, contact your dealer immediately.

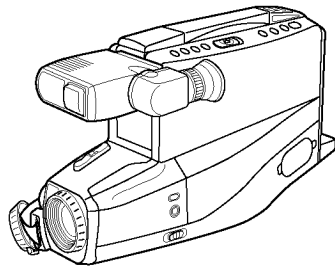

Model CC4271

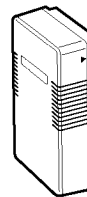

WARNING:
LEAD-ACID
BATTERY.
MUST BE
DISPOSED OF
PROPERLY.

Rechargeable 10-Volt Battery
Stock No. EP096FS

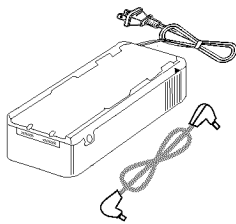

Caution: Do not use this adapter/charger for any purpose other than charging the EP096FS or EP096FL battery pack or supplying power to the camcorder.

AC Adapter/Charger: Stock No. 241044
DC Cable: Stock No. 241308



Shoulder Strap
Stock No. 241305 or
Stock No. 227327

(continued on next page)

First-Time Operation

2. Attach the adapter/charger.

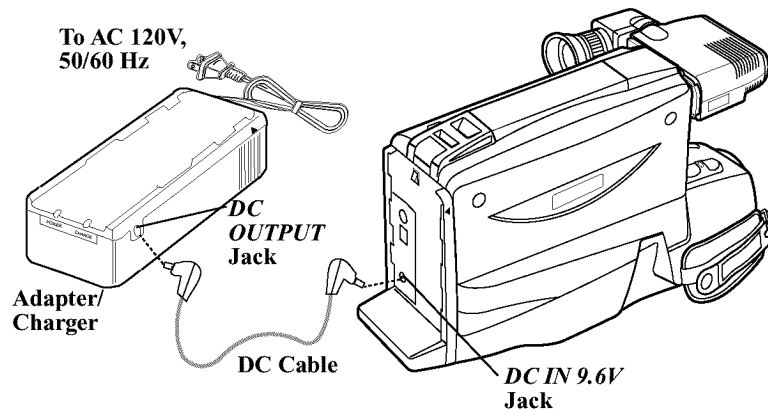

Since the battery must be charged before it can be used the first time, attach the adapter/charger to the camcorder.

1. Attach one end of the adapter/charger's DC cable to the *DC OUTPUT* jack on the side of the adapter/charger.

2. Attach the other end of the cable to the *DC IN 9.6V* jack on the camcorder.

3. Plug the adapter/charger's plug into an operating outlet.

4. *Details are on page 14.*

3. Adjust the handstrap, remove lens cap, and attach it to the handstrap.

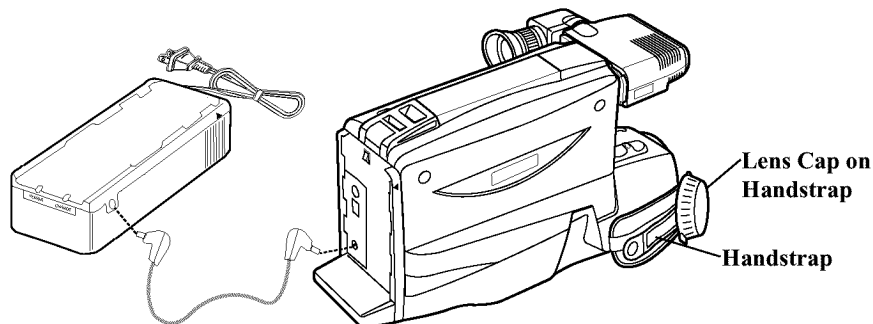

1. Open the handstrap, insert your hand, and adjust the handstrap to fit your hand.

2. Remove the lens cap and attach it to the handstrap *as shown*.

First-Time Operation

4. Insert a tape.

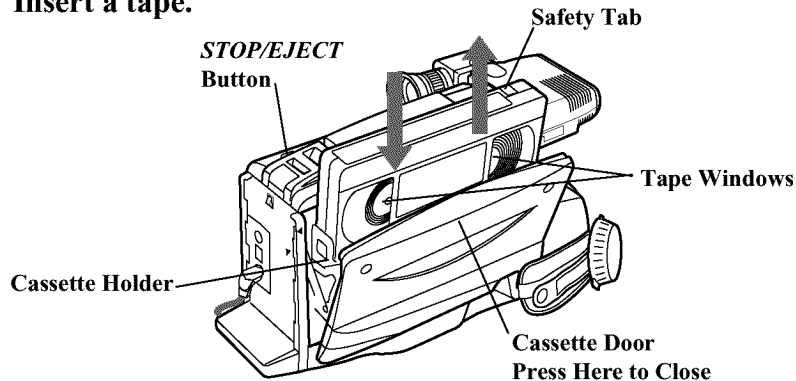

1. Press *STOP/EJECT* to open the cassette compartment.
2. Insert the cassette with the safety tab facing up and the tape windows facing out.
3. Press the cassette down gently until it locks into place, and close the cassette compartment door.
4. *Details are on page 21.*

5. Turn on the camcorder.

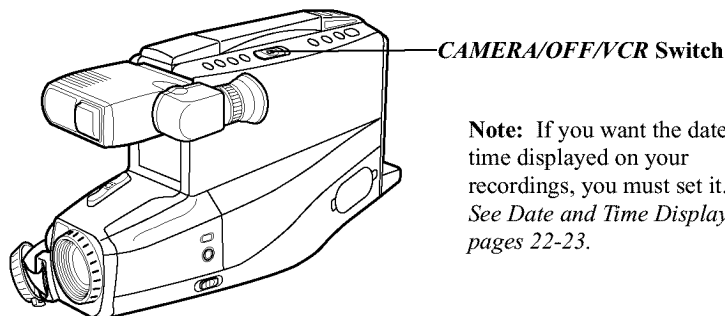

- Press and hold the small button on the *CAMERA/OFF/VCR* switch while you slide it to *CAMERA*. The camcorder enters record-pause.
- The position of this switch tells the camcorder whether you want to record (*CAMERA*), turn the power off (*OFF*), or play back tapes (*VCR*).
- The camcorder automatically turns off if it remains in record-pause for five minutes. Place the switch to *OFF* and then back to *CAMERA*.

(continued on next page)

First-Time Operation

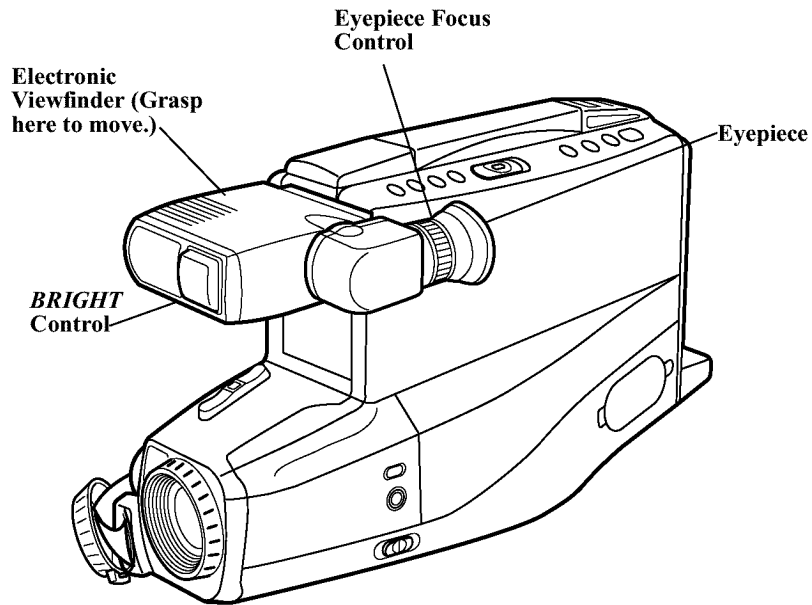

6. Adjust the viewfinder and eyepiece focus control.

- Grasp the viewfinder and rotate it horizontally.
- Pull the viewfinder out from the camcorder and rotate the eyepiece into a comfortable viewing position.
- Turn the eyepiece focus control to adjust the focus of the viewfinder for your vision.
- Adjust the brightness of the image in the viewfinder by turning the *BRIGHT* control.

Caution: Pulling on the eyepiece might damage the eyepiece or camcorder.

First-Time Operation

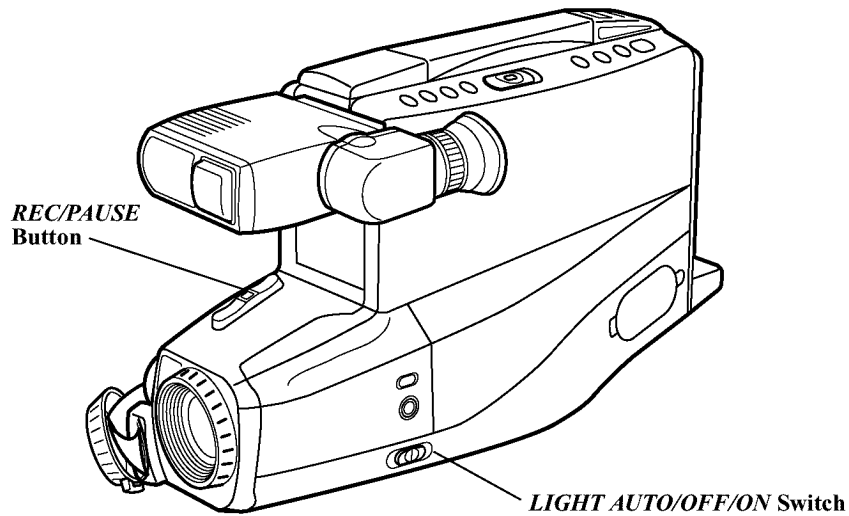

7. Set the *LIGHT AUTO/OFF/ON* switch to *AUTO*.

- The color enhancement light helps you create brighter and sharper images.
- Set the *LIGHT AUTO/OFF/ON* switch to *AUTO* if you want the color enhancement light to turn on automatically when you aim the camcorder at a dark object and turn off when you aim it at a bright object.
- *Details are on pages 12-13.*

8. Start and stop recording.

- Press and release the *REC/PAUSE* button to start recording. *REC* appears in the viewfinder when the camcorder is recording.
- Press and release the *REC/PAUSE* button again to stop recording. The camcorder is now in the record-pause mode (**||** appears in the viewfinder when the camcorder is in record-pause).

(continued on next page)

First-Time Operation

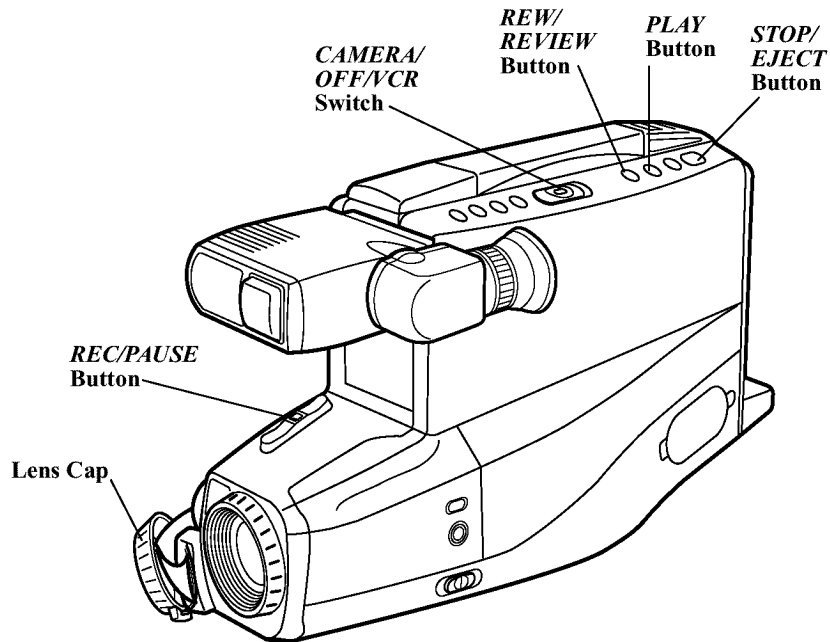

9. Play back what you have recorded.

1. Press the *REC/PAUSE* button to pause recording.
2. Press and hold the small button on the *CAMERA/OFF/VCR* switch while you slide it to *VCR*.
3. Press *REW/REVIEW* to rewind the tape.
4. Press *PLAY* to play back the tape.
5. Press *STOP/EJECT* when you are finished playing back the tape.

Details on viewfinder playback are on pages 38-39.

10. Set the *CAMERA/OFF/VCR* switch to *OFF* to turn off the camcorder.

11. Replace the lens cap.

First-Time Operation

12. Review camcorder's operating controls.

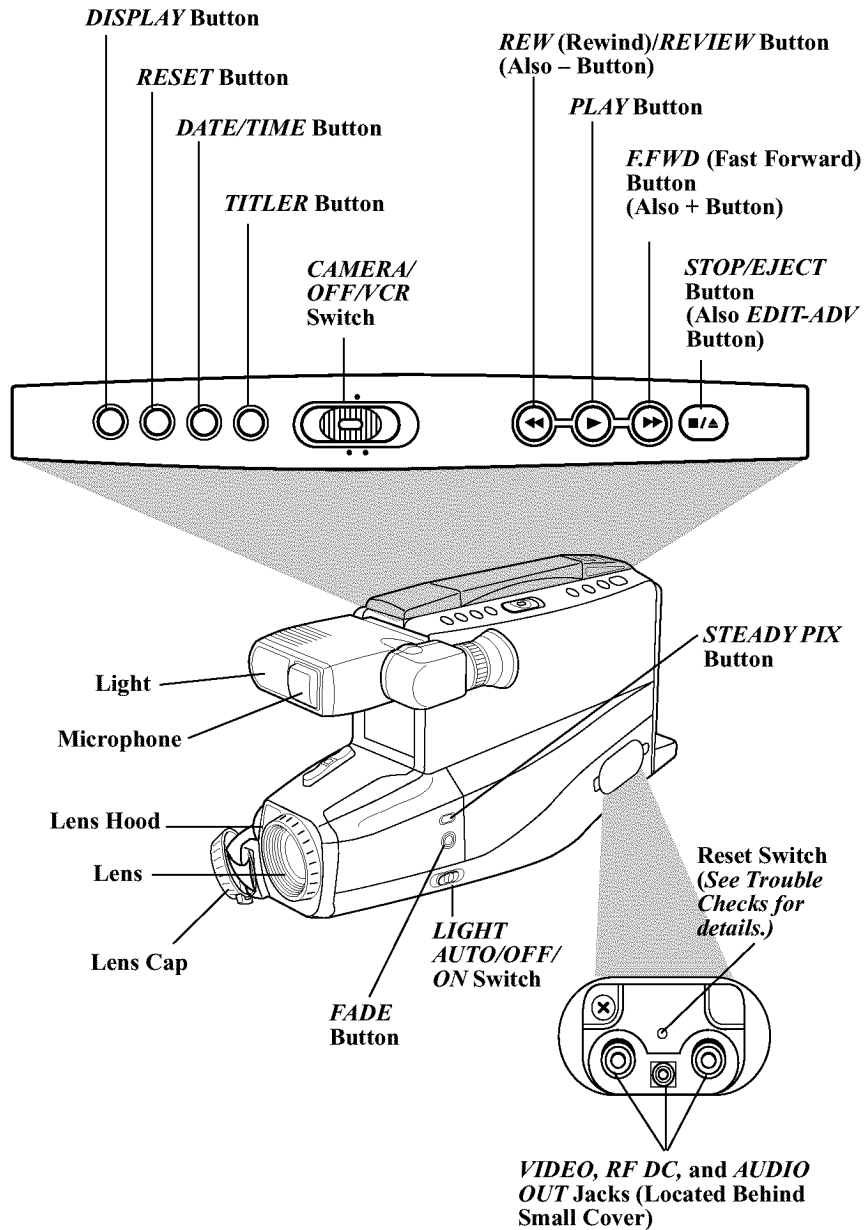

(continued on next page)

First-Time Operation

12. Review camcorder's operating controls. (continued)

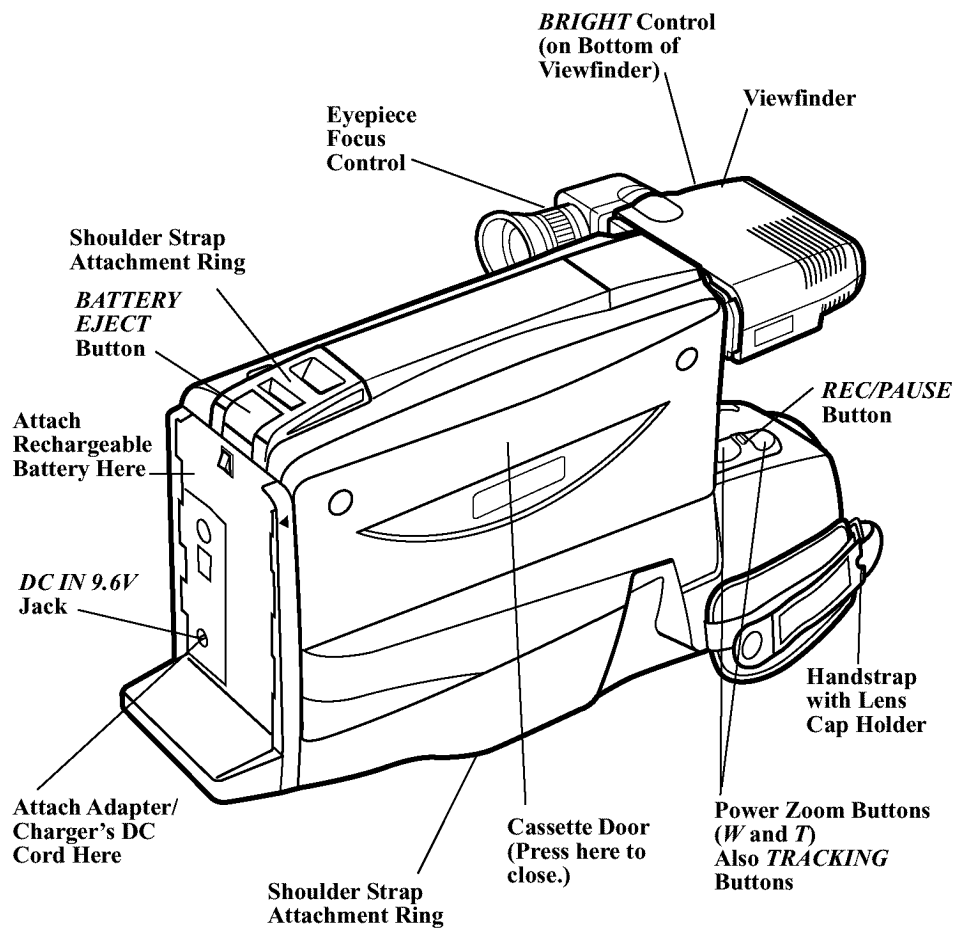

Included Accessories

Attach the Shoulder Strap

The camcorder's shoulder strap is designed to let you carry the camcorder from your shoulder and – when you are ready to shoot – bring the camcorder to shooting position in one quick movement.

To Attach the Shoulder Strap

1. Unfasten one end of the shoulder strap from the buckle. Make sure you leave the buckle on the strap.
3. Thread the end of the strap back through the buckle making sure it is threaded over the outer strap. Make sure the strap is not twisted.

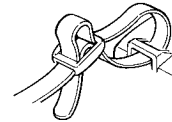
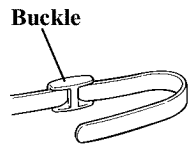

2. Thread one end of the shoulder strap through one of the shoulder strap rings as shown below.
4. Repeat steps 1-3 to attach the other end of the strap.
5. Pull on the straps and make sure they are securely fastened before using the shoulder strap to support your camcorder.

Shoulder Strap Attachment Ring

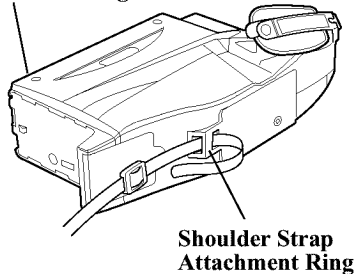

Cautions: When carrying the camcorder with the shoulder strap, rotate the viewfinder up to its original position. This helps prevent possible damage to the viewfinder from bumping against your body as you move.

Make sure the shoulder strap is firmly attached before using it to carry the camcorder.

Included Accessories

Built-In Color Enhancement Light

The built-in color enhancement light automatically adds light when needed. To operate the video light, press and hold the small button on the *CAMERA/OFF/VCR* switch while you set it to *CAMERA*.

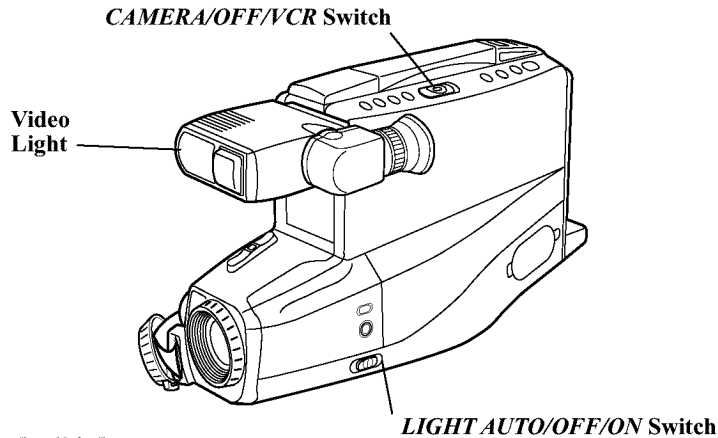

To Use the Light

Set the *LIGHT AUTO/OFF/ON* switch.

- To turn the light on, set the switch to *ON*.
- If you want the light to come on automatically when the camcorder senses there is insufficient light, set the switch to *AUTO*.

Notes: For the light to operate in *AUTO*, you must have a tape in the camcorder.

If the lighting condition is unstable, the light may turn on and off. Set the light to *ON* or *OFF*.

- To turn the light off, set the switch to *OFF*. To save battery power, turn the light off when you are not recording.

Notes: When the light is turned on, the camcorder may turn off if the battery's power is low even though the battery level indicator is not flashing.

Avoid bumping or shaking the light when in use. The light's bulb is sensitive when hot and might burn out.

Cautions:

Do not operate the video light closer than one foot to people or other objects.

The video light and front surface become very hot. Do not touch them during operation or right after use. Serious injury might result.

To prevent overheating, do not block or cover the ventilation holes on the color enhancement light.

Do not place the camcorder in a carrying case right after using the light.

Never operate the video light close to flammable or explosive material.

Do not allow water to drop on the light when in operation.

Included Accessories

Replace Light Bulb

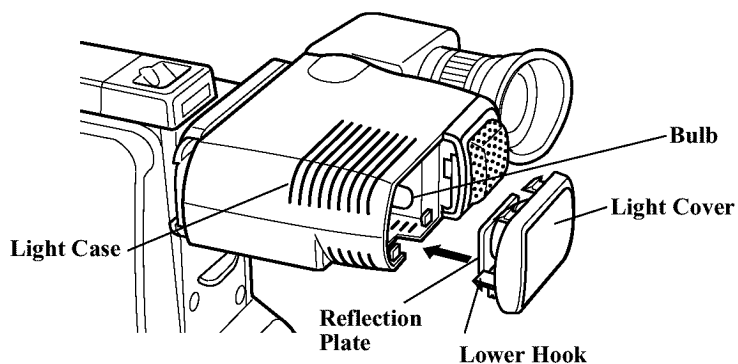

Remove and Replace the Light Bulb

1. Press and hold the lower hook of the light cover while removing the light cover from the light case.
2. Replace the light bulb.

Note: See the installation instructions packed with the replacement bulb for detailed instructions.

3. To replace the light cover, pass the bulb through the hole of the

reflection plate and attach the lower hook to the light case on the camcorder.

4. Press gently on the front of the light cover until it locks into place.

Note: Make sure the front cover of the light is properly attached.

Cautions:

Do not touch the light bulb with your fingers. If you accidentally touch the bulb, wipe it with a soft cloth. A dirty bulb might cause smoke and have a reduced service life.

When replacing the bulb, only use #221111 to reduce the risk of fire and other hazards.

Power Your Camcorder

Use the Adapter/Charger to Power Your Camcorder

The adapter/charger attaches to the camcorder and lets you power your camcorder directly from standard household power. The adapter/charger operates on 120 volts, 50/60 Hz, and can be used to power the camcorder or recharge the battery.

Caution: Do not attempt to use a “power converter” to use your AC adapter/charger on a power source other than 120 volts, 50/60 Hz, or the adapter/charger and camcorder might be damaged. If you wish to operate the AC adapter/charger on a power source other than 120 volts, 50/60 Hz, use only a transformer-type power converter. **Do not use “solid-state” or “switching-type” power converters. They will damage your AC adapter/charger.** An optional CPS014, shown on page 46, is designed for use on 100-240 volts, 50/60 Hz.

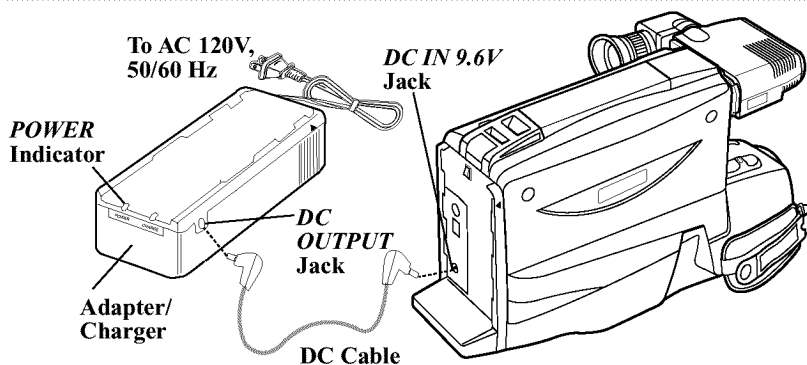

Caution: Do not use this adapter/charger for any other purpose other than charging the EP096FS or EP096FL battery pack or supplying power to the camcorder.

Attach Adapter/Charger

1. Attach one end of the adapter/charger's DC cable to the *DC OUTPUT* jack on the adapter/charger.
2. Attach the other end of the cable to the *DC IN 9.6V* jack on the camcorder.
3. Plug the adapter/charger's plug into an operating outlet. The *POWER* indicator on the adapter/charger lights when it is properly connected.

Notes: The adapter/charger cannot charge the battery and operate the camcorder at the same time. If you connect both, the adapter/charger will power the camcorder. Remove the

adapter/charger's cable from the *DC OUTPUT* jack to charge the battery.

When using the adapter/charger to power the camcorder, the battery level indicator might display . This indicator is used for battery operation and has no meaning when using the adapter/charger to power the camcorder.

Remove Adapter/Charger

1. Unplug the adapter/charger from the wall outlet.
2. Remove the DC cable from the adapter/charger and camcorder.

Power Your Camcorder

Use the Battery to Power Your Camcorder

Charge the Battery

You must charge the battery before you can use it the first time. Initial charging will take approximately two hours. The camcorder's operating time depends on how often you turn the power on and off and how much you use zoom and pause. Conserve battery power by turning the camcorder off during recording breaks.

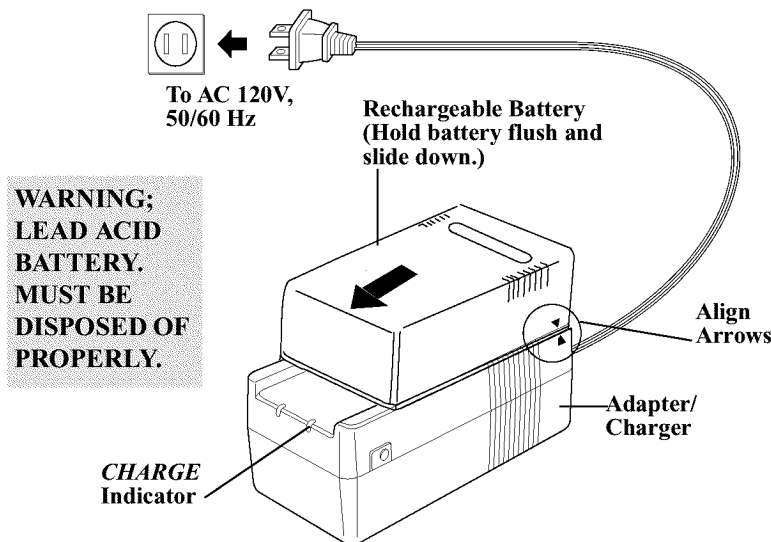

Caution: When a battery is attached to the adapter/charger, do not turn them upside down. The battery might fall off and be damaged or cause injury.

Charge the Battery

If the DC cable is attached to the *DC OUTPUT* jack on the adapter/charger, remove it.

1. Align reference mark on battery with mark on adapter/charger.
2. Hold the battery flush against the adapter/charger and slide it in the direction of the arrow.
3. Plug adapter/charger into nearest AC outlet (120V, 50/60Hz).
4. If the battery is properly connected, the adapter/charger's *CHARGE* indicator lights.

Note: Your battery will provide better service if you charge it before and after use and store it at room temperature.

5. Remove the charged battery by sliding it up and off the adapter/charger.
6. Attach the charged battery to the camcorder *as shown on the next page*.

Power Your Camcorder

Use the Battery to Power Your Camcorder (continued)

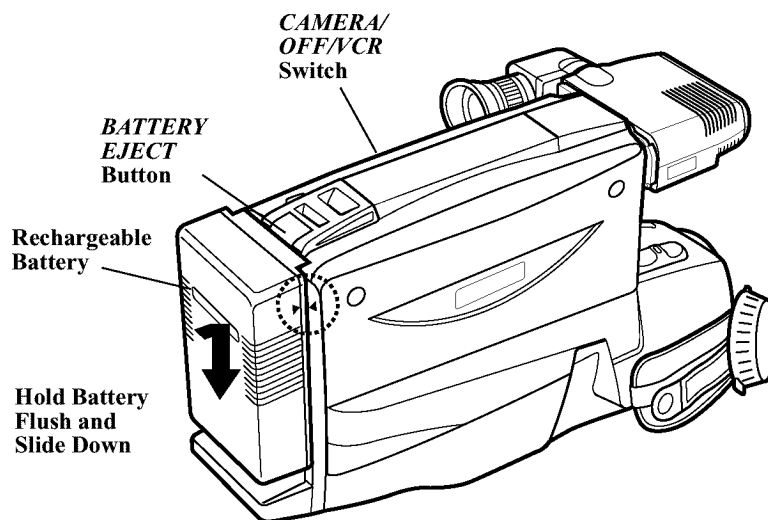

Attach the Charged Battery

If the DC cable is attached to the camcorder, remove it before attaching the battery.

1. Align the reference arrow on the battery to the arrow on the back of the camcorder.
2. Hold the battery flush against the camcorder while sliding it down in the direction of the arrow.

3. Press and hold the small button on the *CAMERA/OFF/VCR* switch while you slide it to *CAMERA*.

Remove the Battery

1. Set the *CAMERA/OFF/VCR* switch to *OFF*.
2. Press and hold the *BATTERY EJECT* button while you remove the battery.

ATTENTION: LEAD ACID BATTERY MUST BE DISPOSED OF PROPERLY. THE PRODUCT THAT YOU HAVE PURCHASED USES A RECHARGEABLE BATTERY. AT THE END OF ITS USEFUL LIFE, UNDER VARIOUS STATE AND LOCAL LAWS, IT MAY BE ILLEGAL TO DISPOSE OF THIS BATTERY INTO THE MUNICIPAL WASTE STREAM. CHECK WITH YOUR LOCAL SOLID WASTE OFFICIALS FOR DETAILS IN YOUR AREA FOR RECYCLING OPTIONS OR PROPER DISPOSAL.

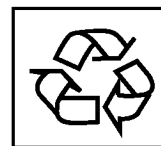

Pb

Power Your Camcorder

Use the Battery to Power Your Camcorder (continued)



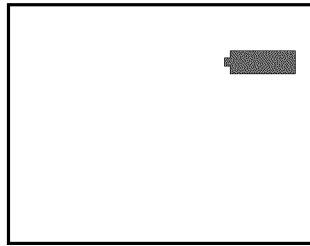

Battery Level Indicator

The battery level indicator appears in the viewfinder and shows you the amount of power in the rechargeable battery.



**Battery Level Indicator Display
in Viewfinder**

Note: If the battery level display does not appear, press *DISPLAY*.

- When  appears, the battery is fully charged.
- As the power is used  and  appear.
- When the battery power is almost gone,  flashes in the viewfinder. Recharge the battery or use the adapter/charger before continuing to use the camcorder. Set the *CAMERA/OFF/VCR* switch to *OFF* to turn off the camcorder before replacing the battery.

Notes: When recording using the rechargeable battery, the battery level indicator flashes to warn you of low battery power even if you do not have the battery level indicator displayed.

The battery level indicator will not be recorded on the tape when it appears in the viewfinder.

The battery level indicator has no meaning when you use the adapter/charger or optional car cord to power the camcorder.

Cautions: When a battery reaches empty during use, the camcorder turns off. The battery should still have enough reserve power to eject the cassette when you press *STOP/EJECT*.

If the camcorder does not eject the cassette when you press *STOP/EJECT*, **do not force the cassette door open**. This will damage your camcorder.

Before attempting to eject the cassette, power the camcorder with the adapter/charger or recharge the battery.

Power Your Camcorder

Use the Battery to Power Your Camcorder (continued)

Battery Care

- Your battery will provide better service and longer performance if you charge it before and after use, and store it at normal room temperature.
- The battery should be charged at a temperature of 32°F-95°F (0°C-35°C) to prevent damage.
- Do not operate the battery at temperatures below 14°F (-10°C) or above 95°F (35°C). The battery might be damaged if operated at temperatures above 122°F (50°C). Operation time will decrease at extremely low temperatures.
- After repeated chargings and use the operation time will decrease. When the operation time becomes too short to be useful, it is time to replace the battery.

Battery Storage

- Store the battery at normal room temperature.
- Lead acid batteries discharge if not used. Recharge the battery at least once ever six months or you may not be able to recharge it.
- A battery stored for a long period might not supply power for the specified time. Additional rechargings might help restore the battery's operation time.

Battery Safety Precautions

- Batteries being recharged that have not been used for an extended period may continue to charge after the normal time. Do not charge a battery for more than 24 hours.
- If the *CHARGE* indicator on the adapter/charger starts flashing, remove the battery, and reattach it. If after several attempts, the indicator continues to flash, your battery cannot take a charge and must be replaced.
- Throwing the battery into a fire or exposing the battery to excessive heat – over 149°F (65°C) could be hazardous.
- Do not short the battery's terminals.
- Allow the battery to cool down before attaching it to the adapter/charger. The *CHARGE* indicator will not light and the battery will not charge if you attach a hot battery.
- Do not attempt to disassemble or modify the battery. There are no user-serviceable parts inside.
- Use the battery only with specified AC adapter/chargers and camcorders.
- If leakage from a damaged battery contacts your skin or clothing, wash it off immediately with running water.

Power Your Camcorder

Use the RCA Optional Car Cord Adapter

The optional DCC096 car cord *shown on page 45* allows you to power your camcorder from the cigarette lighter socket of a car, truck, or RV. It converts 12-volts to a 9.6-volt output.

Note: Consult the installation and operating instructions enclosed with the DCC096 for complete operating instructions.

Caution: The DCC096 car cord is designed to be used only with vehicles having 12-volt negative ground electrical systems.

Warning: To avoid possible damage to the camcorder, use only the DCC096 car cord. It has positive tip polarity and is capable of converting 12 volts to 9.6 volts.

Use the DCC096 Car Cord Adapter

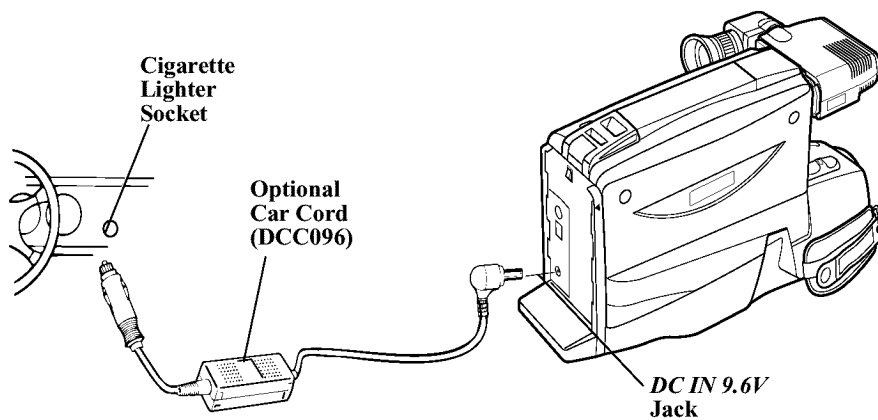

1. Set the *CAMERA/OFF/VCR* switch to *OFF* to turn off the camcorder.
2. If the battery or DC cable is attached to the camcorder, remove it.
3. Insert the small plug on the car cord to the *DC IN 9.6V* jack located on the back of the camcorder.
4. Take the vehicle's cigarette lighter out of the socket.
5. Insert the car cord's cigarette lighter plug into the vehicle's cigarette lighter socket.
6. Press and hold the small button on the *CAMERA/OFF/VCR* switch while you set it to *CAMERA* to turn on the camcorder.

Notes: Consult the vehicle owner's manual to see if the vehicle's ignition switch must be turned on before the DC car cord will operate. When using the car cord to power the camcorder, the battery level indicator has no meaning.

Videocassettes

Make sure you select good quality tapes for your camcorder. Use of poor quality tapes or tapes that have been damaged or mishandled can contaminate the video heads, resulting in a snowy picture or no picture at all during playback. Because there is no control over the type of tape purchased or rented by consumers, **head cleaning is not covered under warranty**. It is considered normal maintenance.

If a snowy picture or no-picture condition persists, consider the use of a chemical nonabrasive head-cleaning tape. Be sure to follow the directions with the head-cleaning kit carefully. Improper use of a head cleaner might damage your camcorder.

Erase Protection – Safety Tab

You can use your videocassettes over and over again. To erase a previous recording, just record over it.



To prevent accidental erasure, break off the tab.

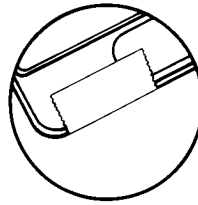

To record on the tape again, cover the hole with vinyl tape.

Record and Playback Speed and Times

The camcorder records and plays back in VHS standard speed (SP). Listed below are the maximum recording times for popular VHS cassettes.

CASSETTE	RECORDING TIME
T-60	60 Min.
T-120	2 Hrs.
T-160	2 Hrs., 40 Min.
T-180	3 Hrs.

Videocassettes

Insert and Remove Cassettes

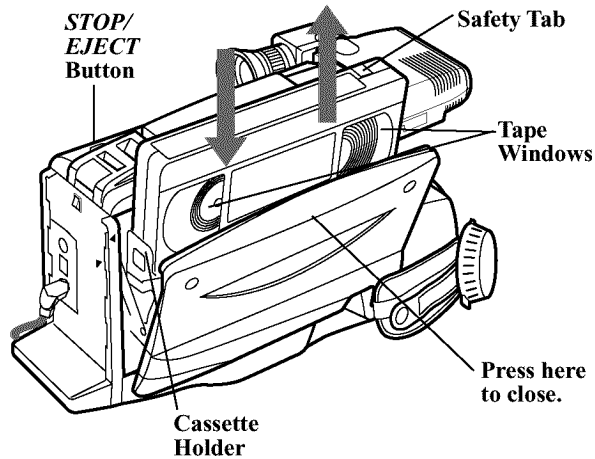

Caution: Insert the cassette only one way with the tape wheel facing up and the tape windows facing out. The cassette should slide easily into the holder. Gently push the cassette down until it locks into place.

1. Attach a power source to the camcorder.
2. Press the *STOP/EJECT* button. The cassette holder opens automatically.
3. Insert the cassette with the tape wheel facing up and tape windows facing
4. Gently close the cassette holder with your hand.

Cassette Care and Storage

- When you are finished with a cassette, rewind it, remove it from the camcorder, and label it.
- Store cassettes vertically in their protective cases at normal room temperatures. Do not leave your camcorder or cassettes in a car or outdoors for an extended period. Excessive heat or cold might damage your cassettes.
- Keep the cassette away from strong magnetic fields such as electric motors and other devices.
- Keep dust from entering the cassette compartment. All dust is abrasive and will cause excessive wear on the tape and the camcorder's recording or playback heads.
- Do not use cassettes with damaged or spliced tape.
- Do not use a cassette if it has been damaged or exposed to moisture. The tape might jam and/or damage your camcorder.
- Break off the safety tab to prevent accidental erasure of your recording.

Date and Time Display

Set the Time and Date

You must set the correct date and time before it can be displayed and recorded on your tapes. The built-in clock cell must be charged *as described on the next page.*

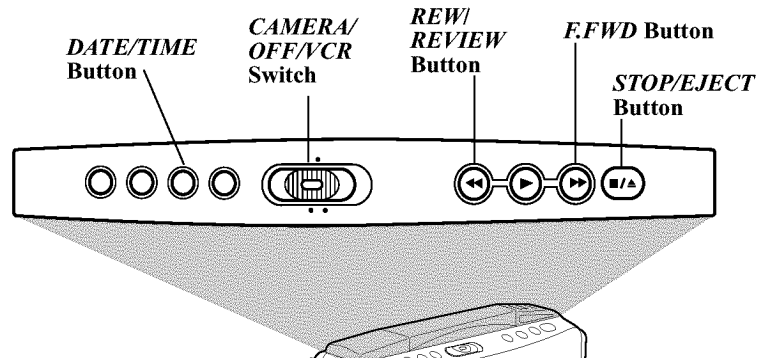

1. Attach a power supply to the camcorder.
2. Press and hold the small button on the *CAMERA/OFF/VCR* switch while you set it to *CAMERA*.
3. Press the *DATE/TIME* button to display the date and time in the viewfinder.
A flashing cursor lets you know which part of the display you are setting. If the flashing cursor does not appear, press and hold *DATE/TIME* and then press *STOP/EJECT*.
4. Repeatedly press *F.FWD* or *REW/REVIEW* until the correct month appears. Press and hold the button to advance the digits faster.
5. When the correct month is displayed, press *STOP/EJECT*. The cursor moves to the next part of the display.
6. Repeat steps 4 and 5 to set the correct month, day, year, hour, minute(s), and *AM/PM*.
7. After setting *AM* or *PM*, press the *DATE/TIME* button to remove the flashing cursor and start the internal clock.

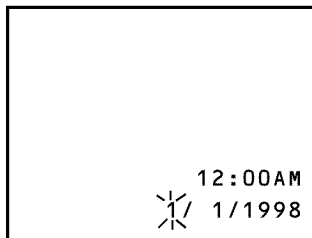

To Correct the Date or Time

To correct the date or time, press and hold the *DATE/TIME* button and then press *STOP/EJECT*. The display and the flashing cursor appear. Use *STOP/EJECT*, *F.FWD*, and *REW/REVIEW* to correct the time or date. Press *DATE/TIME* to remove the flashing cursor and start the clock.

Date and Time Display

Record the Time and Date, *AUTO* Date, Auto *TITLE*, or Date

The time and date, *AUTO* date, auto *TITLE*, date only, or no date can be recorded on your tape. Whenever one of these displays appears, it will be recorded.

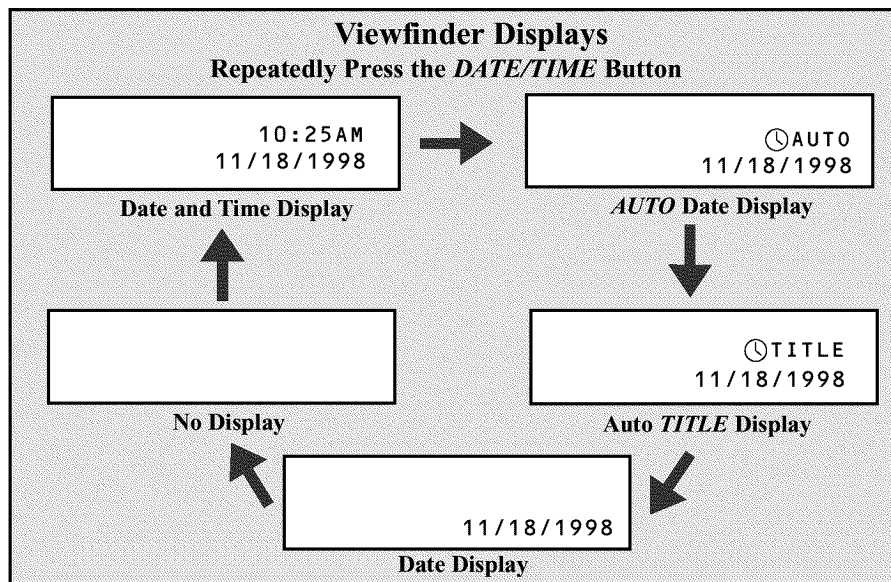

To Select the Display to Record

1. Repeatedly press *DATE/TIME* to select the display you want to record.
 - **Date and Time Display:** The date and time will be displayed and recorded.
 - ⌚ ***AUTO* Date:** The date is automatically recorded for approximately 10 seconds at the beginning of the recording.
 - ⌚ ***TITLE*:** The date and title you have created are displayed and recorded for approximately 10 seconds at the beginning of the recording.
 - **Date Display:** The date is displayed and recorded.
 - **No Display:** No display is displayed or recorded.

Charge the Built-in Clock Battery

The camcorder has a built-in rechargeable battery **that must be charged approximately every two months.**

1. Attach a power supply and set the *CAMERA/OFF/VCR* switch to *OFF*.
2. Leave the power supply attached at least 24 hours.

Cautions: If this battery is not charged every two months, it will over-discharge and shorten its useful life.

Do not attempt to replace this battery. Take the camcorder to an authorized RCA Service Center.

Recording

Use the Viewfinder

The camcorder's viewfinder is a miniature monitor that displays the picture seen by the camcorder when recording.

Adjust Viewfinder for Convenient Viewing

For convenient viewing, rotate the viewfinder horizontally, pull it out from the camcorder, and adjust the eyepiece.

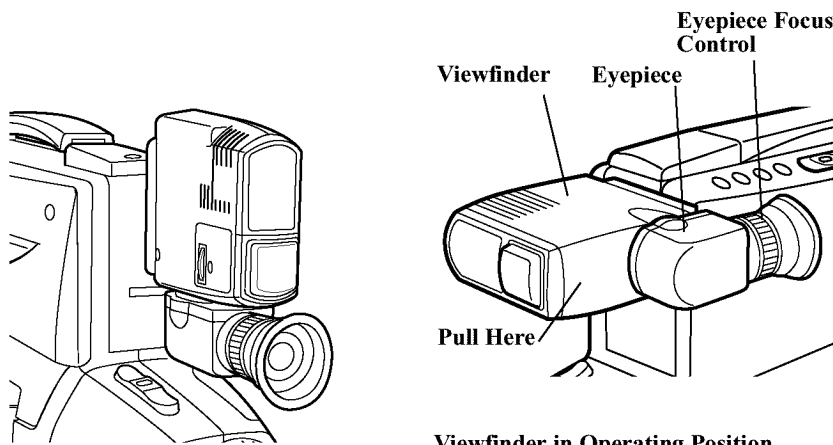

Viewfinder in Carrying or Storing Position

Viewfinder in Operating Position

Caution: Do not pull on the eyepiece. Do not force the eyepiece to rotate completely around. This might damage the viewfinder and/or the camcorder.

When carrying the camcorder with the shoulder strap, put the viewfinder back in its original position. This helps prevent possible damage to the viewfinder from bumping against your body as you move.

Eyepiece Focus Control

The eyepiece focus control lets you set the focus of the viewfinder for your vision. If you wear eyeglasses, you probably can operate the camcorder without them.

It is easiest to set the correct focus by focusing on one of the viewfinder's on-

screen displays. Look through the viewfinder and adjust the eyepiece focus control for your vision.

The eyepiece focus control does not affect the focus of the picture actually recorded by the camcorder.

Recording

Use the Viewfinder (continued)

Tilt Adjustment

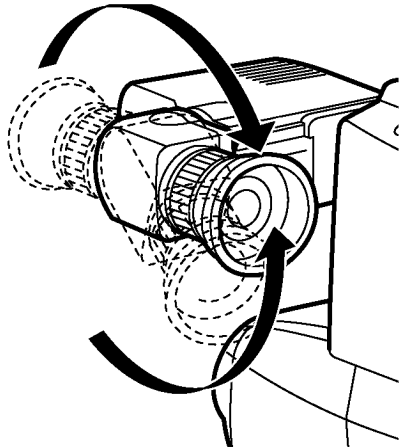

Cautions: Do not pull on the eyepiece. Do not force the eyepiece to rotate completely around. This might damage the viewfinder and/or the camcorder.

BRIGHT Control

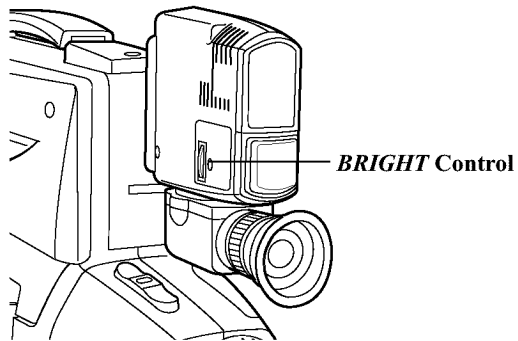

The brightness of the viewfinder can be adjusted by rotating the *BRIGHT* control. This does not affect the picture being recorded by the camcorder.

Recording

Viewfinder Displays

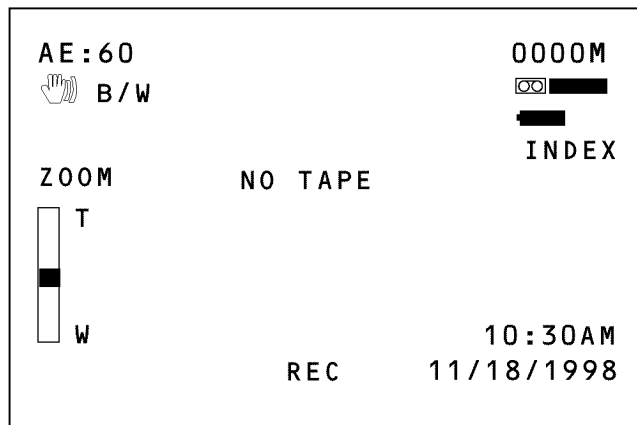

AE:60 (Auto Exposure) Shutter Speed



Press the *DISPLAY* button to display the shutter speed selected by the camcorder.

Battery Level Indicator (█)

Press the *DISPLAY* button to display the amount of time left on the rechargeable battery. *Details are on page 17.*

Fade Indicator (B/W)

Press the *FADE* button to select a fade.



- Select  to white fade.
- Select  to wipe fade.
- Select  to zoom fade.
- Select *B/W* to black-and-white fade.
- *Details are on page 32.*

INDEX Indicator

Press the *DISPLAY* button to display this indicator when the camcorder is placing an index mark on the tape. *Details are on page 30.*

Status Displays

The following displays appear to tell you the status of the camcorder.

- The *REC* indicator appears during recording.
- The  indicator appears when the camcorder is fast-forwarding.
- The  indicator appears when the camcorder is rewinding.
- The  indicator appears during record-pause.

Steady Pix Indicator (👉)

To turn the steady pix feature on or off, press the *STEADY PIX* button.  appears when steady pix is turned on. *Details on page 33.*

Recording

Tape Counter with Memory Stop (0000M)

Press the *DISPLAY* button to display the tape counter. The tape counter helps locate segments of tape.

- Memory stop is turned on whenever the tape counter appears.
- *Details are on page 34.*

Tape Warnings (TAPE, NO TAPE, and TAPE END)

- *TAPE* flashes when you try to record with the safety tab removed.
- *TAPE* flashes when a damaged tape is inserted. Remove the tape and replace it with a new one.
- *NO TAPE* flashes when you try to record with no cassette inserted.
- *TAPE END* flashes when there is approximately five minutes of recording time left on the tape.
- *TAPE END* briefly appears when you reach the end of the cassette when you're recording.

Time and Date Display

Press the *DATE/TIME* button to display the time and date, *AUTO* date, auto *TITLE*, date only, or no date when the camcorder is in record-pause.

- These displays are recorded on the tape when they appear in the viewfinder.
- *Details are on pages 22-23.*

Tape-Remaining Indicator (00 ■■■■)

Press the *DISPLAY* button to display the tape-remaining indicator. This display shows the approximate amount of tape left for recording or playback. *Details are on page 30.*

Zoom (Z) and ZOOM Indicators

- The zoom indicator (Z) appears when you use the power zoom buttons (*T* and *W*).
- *ZOOM* appears when you zoom with the *T* button more than 16 times.
- *Details are on page 31.*

Recording

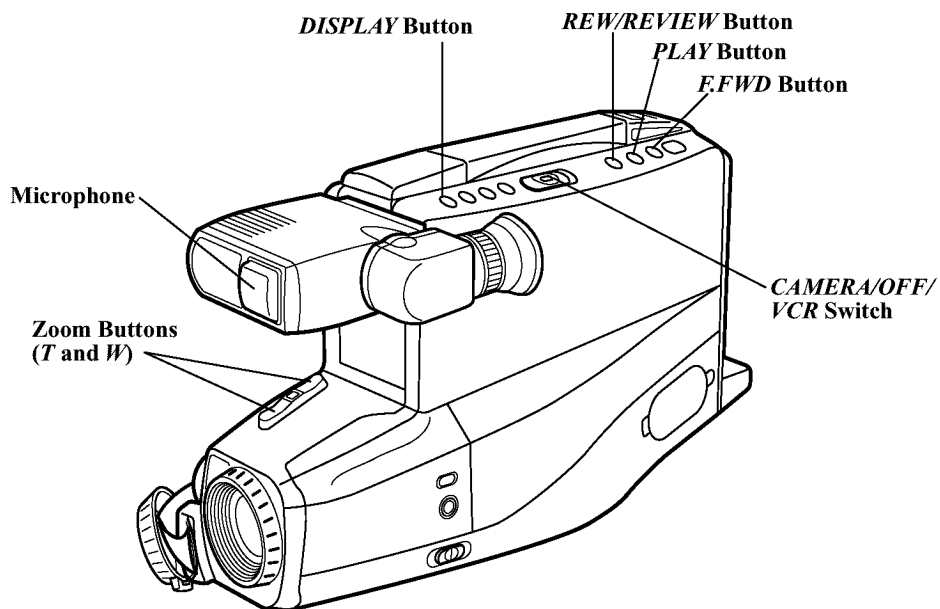

***DISPLAY* Button**

The *DISPLAY* button lets you remove the battery level, steady pix, tape speed, tape counter with memory stop, remaining tape display, index, fade, and zoom indicators from the viewfinder.

- Press *DISPLAY* to remove the indicators.
- Press *DISPLAY* again to display the indicators.

Microphone

The microphone picks up the sound during a recording. It is more sensitive to sounds coming from the direction the lens is pointed.

Auto Shot™ Feature

The camcorder automatically adjusts focus, white balance, iris, shutter speed, and light according to the recording conditions.

Recording

Camera Edit Feature

The camera edit feature allows you to position the tape when the camcorder is in record-pause. Press and hold the small button on the *CAMERA/OFF/VCR* switch while you slide it to *CAMERA*.

- Press and hold *REW/REVIEW* to visually search the recorded tape in reverse.
- Press and hold *F.FWD* to visually search forward on the recorded tape.
- Press and hold *PLAY* to view the recorded tape at normal speed.

When you release the button, the camcorder returns to record-pause at that point on the tape.

Quick Review Feature

Press and release *REW/REVIEW* when the camcorder is in record-pause to review the last few seconds of a recording. The *CAMERA/OFF/VCR* switch must be set to *CAMERA*.

The camcorder will play back the last few seconds of the recording, return the tape to its previous position, and return to record-pause.

Auto Focus

The camcorder focuses on the subject in the center of the viewfinder. Auto focus operates on the telephoto (*T*) side from approximately 2-1/2 feet to infinity. It

operates on the wide-angle (*W*) side from 3/8 inch from the lens surface (macro-focus) to infinity.

Note: When the displays appear, the AE indicator for the shutter speed selected by the camcorder (*1/60, 1/100, 1/120, 1/180, 1/250, 1/350, 1/500, 1/750, 1/1000, 1/1500, 1/2000, or 1/4000*) appears in the viewfinder.

The following conditions may prevent auto focus from operating properly.

- Recording a subject through a window.
- Recording a subject that has a close foreground and a far background.
- Recording two subjects at different distances that overlap.
- Subject that isn't in center of scene.
- Recording in low-light situations.
- Recording a scene with fast motions, like a tennis swing.

Macro Focus

The macro-focus feature lets you focus on objects as close as 3/8 inch from the camcorder lens.

1. Press and hold zoom button *W* until the lens is completely zoomed out.
2. Position the subject in the center of the scene.

Notes: Zooming is not possible when using macro-focus. To change the size of the subject, move the camcorder lens closer or farther away from it.

For best results increase illumination when recording with macro-focus.

Recording

Tape-Remaining Display

The tape-remaining display shows the approximate amount of tape remaining for recording or playback.

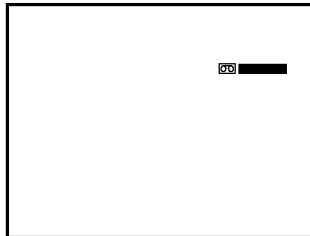







**Tape-Remaining Display
in Viewfinder**

- Press *DISPLAY* to display the tape-remaining indicator in the viewfinder.
- The camcorder takes approximately ten seconds to calculate the tape remaining when you first start playing or recording a tape.

“_ _ _ _ _” appears while the camcorder calculates the amount of tape-remaining.

Once tape-remaining has been calculated, it automatically updates and is readily available as long as the same tape remains in the camcorder.

- When   appears, all or most of the tape remains.
-   and   appear as the tape is being used.
- When the tape is almost at its end, *TAPE END* flashes in the viewfinder.

Electronic Indexing

Each time you begin recording (after the camcorder has been turned off for at least four hours), the camcorder automatically records an index mark at the beginning of the new recording.

When you play back the indexed tape in a VCR that has a compatible indexing feature called “VHS Index Search System” the invisible marks can be located automatically. See your VCR Owner’s Manual for index playback instructions.



**INDEX Display
in Viewfinder**

When the *DISPLAY* button is pressed so the displays appear, *INDEX* appears briefly to let you know the camcorder is recording an index mark.

Note: The camcorder does not record index marks every time you stop and start recording. An index mark is recorded only once – at the start of each day’s recording session (or whenever the camcorder has been turned off for four hours).

Recording

Zooming

Press one of the zoom buttons to zoom in and out for close ups or wide-angle shots.

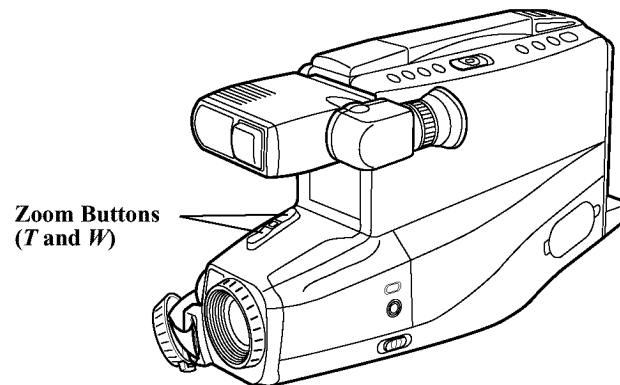

Use the Zoom Buttons (*T* and *W*)

1. To zoom in or out from wide angle to 32 times, press zoom button *T* or *W*.
 - To move the lens in the telephoto (close-up) direction, press *T*.
 - To move the lens in the wide angle direction, press *W*.

When *DISPLAY* is pressed so the displays appear, the zoom level indicator appears in the viewfinder during normal zooming. *ZOOM* appears when you zoom more than 16 times.

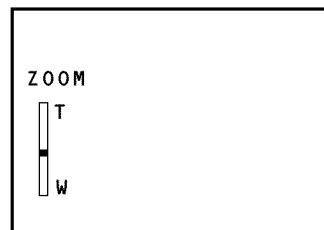

**Zoom Level Indicator
in Viewfinder**



Recording

Fade In and Out of Scenes

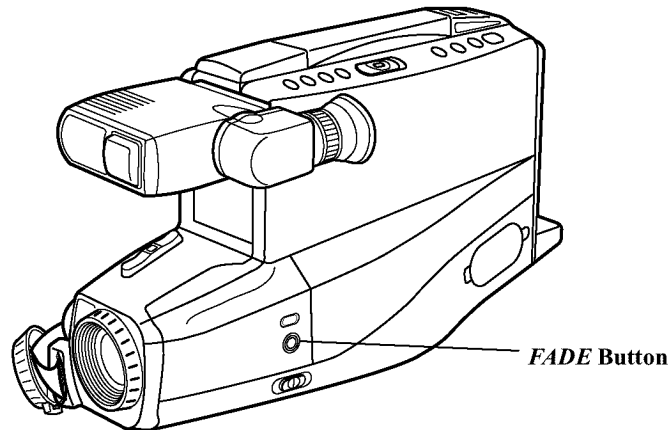
You can add a professional touch to your recordings when you fade in and out of scenes. Both the picture and sound gradually appear or disappear. The speed of the fade is controlled by the camcorder.



Fade In

1. Press *REC/PAUSE* to pause recording.
2. Repeatedly press *FADE* to select the fade you want to use. The indicator for the fade you select will appear.
 - Select  (white) to fade in and out to/from a white screen.
 - Select  (black wipe) to fade in and out to/from a black screen.
 - Select  (zoom) to fade in and out while zooming.
 - Select *B/W* (black-and-white) to fade in and out to/from a black-and-white picture.
 - Select no fade indicator if you do not want to fade in or out.
3. Press *REC/PAUSE* to start recording. The picture and sound gradually appear in place of the blank screen.

Fade Out

1. During recording, repeatedly press *FADE* to select a fade.
Note: The last fade used appears the first time you press *FADE*.
2. Press *REC/PAUSE* to stop recording. The picture and sound gradually disappear.

Recording

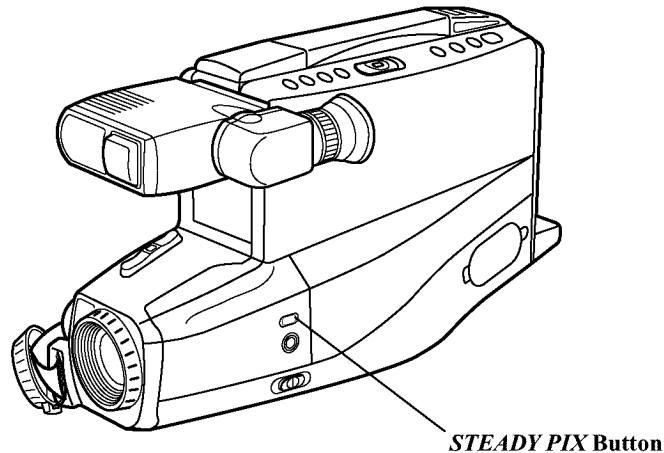



Steady Pix™ Feature

The steady pix feature corrects slight shaking of images during some recording modes.

- While zooming in on a distant subject.
- When recording an approaching small subject.
- When recording while walking or riding in a vehicle.
- When recording through a vehicle's window.

To Use the Steady Pix™ Feature

- Press the *STEADY PIX* button to turn steady pix on. The steady pix indicator () appears in the viewfinder.
- Press the *STEADY PIX* button to turn the steady pix feature off. The steady pix indicator () disappears.

Notes: Turn steady pix off when using a tripod. Steady pix may not operate properly when wide-angle or telephoto lens adapters are used.

There is a small change in the picture size when using steady pix.

Accurate stabilization may not be possible if hand shake is excessive or when shooting the following:

- Subjects with vertical or horizontal stripes.
- Dark or dim subjects.
- Subjects with excessive backlighting.
- Scenes with movement in various directions.
- Scenes with low-contrast backgrounds.

Recording

Tape Counter

The tape counter acts as a handy reference to help you locate tape segments. The memory-stop feature helps locate a certain point on the tape. When the tape counter appears, the tape stops automatically during rewind or fast forward when the tape counter reaches *0000M*.

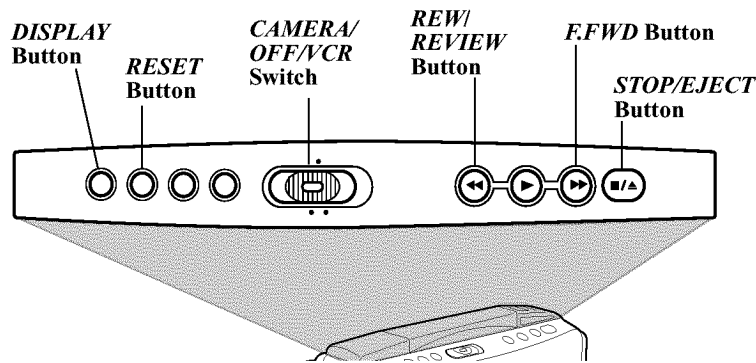

Use the Memory-Stop Feature

1. Press *REC/PAUSE* to pause recording. Make sure the displays appear in the viewfinder. If they do not, press *DISPLAY*.
2. Locate the place on the tape you want to return to, and press *RESET* to reset the counter to *0000M*.

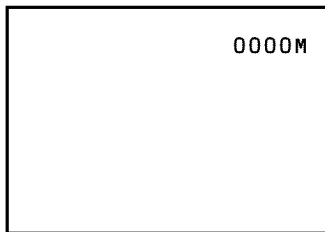

**Tape Counter
With Memory Stop**

4. Press and hold the small button while you set the *CAMERA/OFF/VCR* switch to *VCR*.
5. Press the *REW/REVIEW* button. The tape rewinds to the counter reading of *0000M*.

Notes: Press *DISPLAY* to display or remove the tape counter. Memory stop is turned on whenever the tape counter appears.

The camcorder stops rewinding or fast forwarding when the counter reaches *0000M*. To continue rewinding or fast forwarding, press the button again.

The tape counter automatically resets to *0000M* whenever a cassette is inserted.

3. Continue to record or play the tape. When you want to return to the place

Recording

Titler

You can store a title in memory. The created title can be displayed and recorded at any time. The built-in character register contains more than 45 different characters. Your title can contain up to 32 characters on two lines.

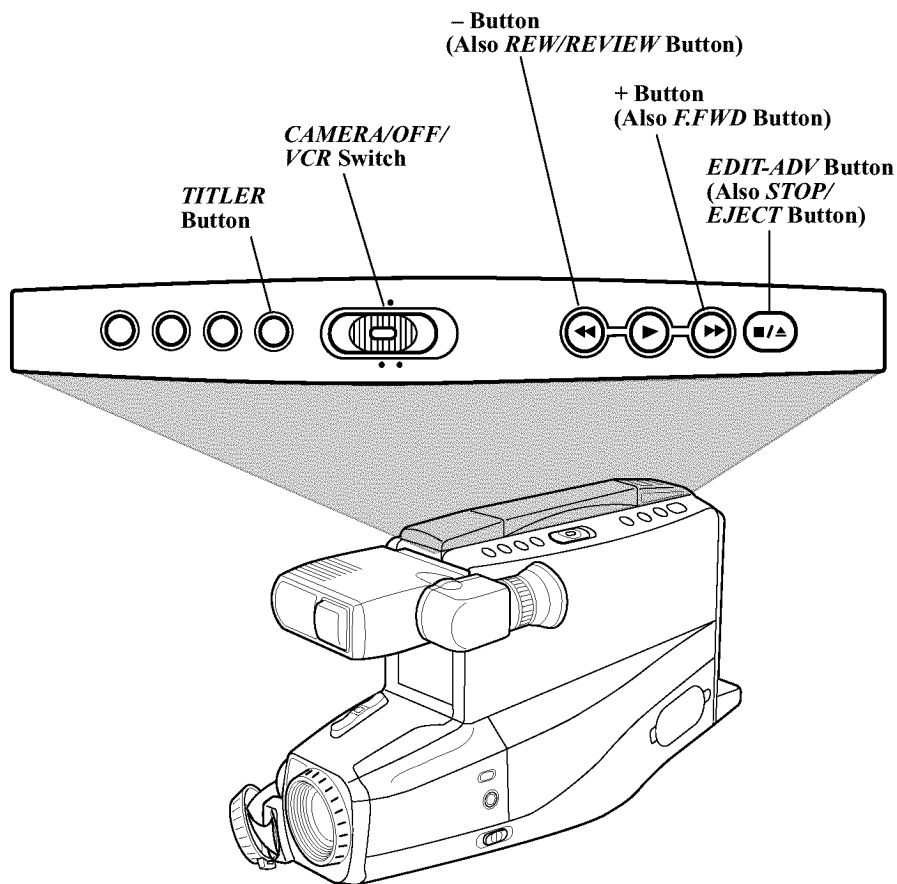

Recording

Titler (continued)

To Create a Title

1. Attach a power source to the camcorder. Press and hold the small button on the *CAMERA/OFF/VCR* switch while you slide it to *CAMERA*.
2. Press *TITLER* to display the titler graphics in the viewfinder. A flashing cursor appears.
3. Press *EDIT-ADV* to move the flashing cursor to the place where you want to begin your title.
4. Select the first character for your title by pressing the + or – button until the character you want appears in the viewfinder.
5. After you have selected the first character, press *EDIT-ADV* to move the flashing cursor to the place where you want the next character to appear.
6. Repeat steps 4 and 5 until you have completed the title.
7. When you are finished, press *TITLER* to store the title and remove the title graphics from the viewfinder.

See the chart below for the characters available.

Remember: Be sure to remove the titler graphics from the viewfinder for normal recording.

To Correct an Error

1. Press *TITLER* to display the titler graphics in the viewfinder.
2. Press *EDIT-ADV* to move the flashing cursor over the character you want to correct.
3. Press the + or – button until the correct character appears.

Note: If you want to delete a character, press + or – until the blank space appears.

Chart of Characters in Titler's Register

A	B	C	D	E	F	G	H	I	J	K	L	M		
N	O	P	Q	R	S	T	U	V	W	X	Y	Z		
0	1	2	3	4	5	6	7	8	9	?	`	.	/	,
-	;	:	<	>	!	(BLANK)								

Recording

Titler (continued)

Record a Title on a Tape in the Camcorder

1. Attach a power source to the camcorder. Press and hold the small button on the *CAMERA/OFF/VCR* switch while you slide it to *CAMERA*.
2. Locate the place on the tape where you want to record the title.
Note: If you record a title on a prerecorded tape, the audio and video is erased where the title is inserted. A three-to-four second pause of blank tape appears before the existing audio and video return.
3. Press *TITLER* to display the titler graphics in the viewfinder.
4. Press *REC/PAUSE* to start recording the title.
5. After you have recorded the title for the desired length of time, press *TITLER* to remove the titler graphics.

The camcorder will now record normally. If you do not want to continue recording, press *REC/PAUSE*.

Remember: Remove the titler graphics for normal recording.

Note: You can also use the automatic title recording feature to automatically record the title and date for 10 seconds when you begin recording. Press the *DATE/TIME* button to display  *TITLE* before starting to record.

Record a Title While Copying a Tape from the Camcorder to Another VCR

1. Attach a power source to the camcorder.
2. Place the tape you want to copy in the camcorder and press and hold the small button on the *CAMERA/OFF/VCR* switch while you slide it to *VCR*.
3. Place a blank tape in the VCR, and place the VCR in record-pause.
4. Start copying the tape from the camcorder to the VCR. *Details are on pages 40-41.*
5. When you see the place on the tape you want to insert the title, press *TITLER*.
6. After you have recorded the title for the desired time, press *TITLER* to stop recording the title.
7. Stop the camcorder and VCR when you are finished copying the tape.

Important Note: Remove the titler graphics for normal recording.

Playback

Viewfinder Playback and Playback Features

The simplest way to watch tapes using the camcorder is in the viewfinder. You can use the playback features during viewfinder playback.

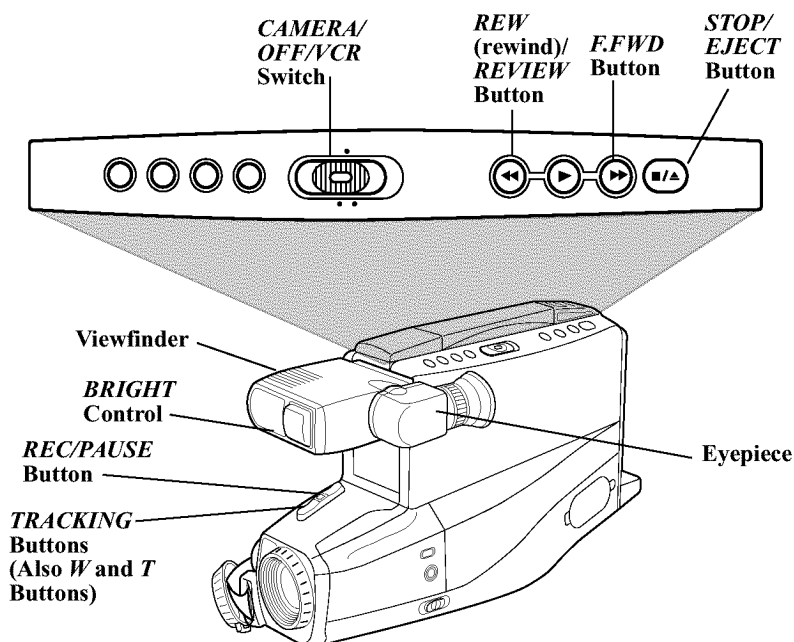

Play Back a Tape in the Viewfinder

1. Attach a power supply.

Attach the adapter/charger, charged battery, or optional car cord.

2. Insert a tape.

- Press **STOP/EJECT** to open the cassette compartment.
- Insert the cassette with the safety tab facing up and the tape windows

facing out. Press the cassette down gently until it locks into place, and close the cassette compartment door.

- The camcorder only plays back tapes recorded in the SP speed.

3. Press and hold the small button on the CAMERA/OFF/VCR switch while you slide it to VCR.

Playback

Play Back a Tape in the Viewfinder (continued)

4. Adjust the viewfinder.

- Grasp the viewfinder and rotate it horizontally. Pull the viewfinder out from the camcorder and rotate the eyepiece into a comfortable viewing position.

Caution: Pulling on the eyepiece might cause damage to the eyepiece or camcorder.

- Turn the eyepiece focus control to adjust the focus of the viewfinder for your vision.
- Rotate the *BRIGHT* control to adjust the brightness.

5. Press *PLAY* to begin playback.

- If necessary, adjust tracking.
- During playback, use the playback features *below*.

6. Press *STOP/EJECT* when you are finished.

Playback Features

Tape Positioning

Press and hold the small button on the *CAMERA/OFF/VCR* switch while you slide it to *VCR*.

- Press and quickly release *REW/REVIEW* or *FWD* to rewind or fast-forward the tape.
- Press *STOP/EJECT* to stop the tape.

Stop-Action Pause

- During playback, press *REC/PAUSE* to “stop the action” and view one frame of the tape.
- Press *REC/PAUSE* again to return to normal playback.

Caution: Pause is designed for momentary interruptions and should not be used for an extended period of time. If the camcorder remains in pause for more than five minutes, it enters the stop mode and turns off to prevent excessive tape wear.

Visual Searching

- During playback, press and hold *FWD* or *REW/REVIEW* if you want to search the tape visually in forward or reverse.
- Release the button to return to normal playback.

Tracking

During playback, streaks might appear in the playback picture. Press either *TRACKING* button to move the streaks up or down and out of the picture.

- During stop-action playback, pressing one tracking button might reduce picture “jitter” (picture bouncing up and down). Some “jitter” is normal.

Remove the tape to reset the tracking to its preset center.

Note: The tracking buttons only affect tape playback. They have no effect during recording.

Playback

Playback on TV (or VCR) with Audio/Video Inputs

To connect your camcorder to a TV monitor (or VCR) with audio and video inputs, you need an optional audio/video cable, such as VH83 shown on page 47. If your TV is already connected to a VCR, attach the camcorder to the VCR and watch what the camcorder is recording or playing on the TV.

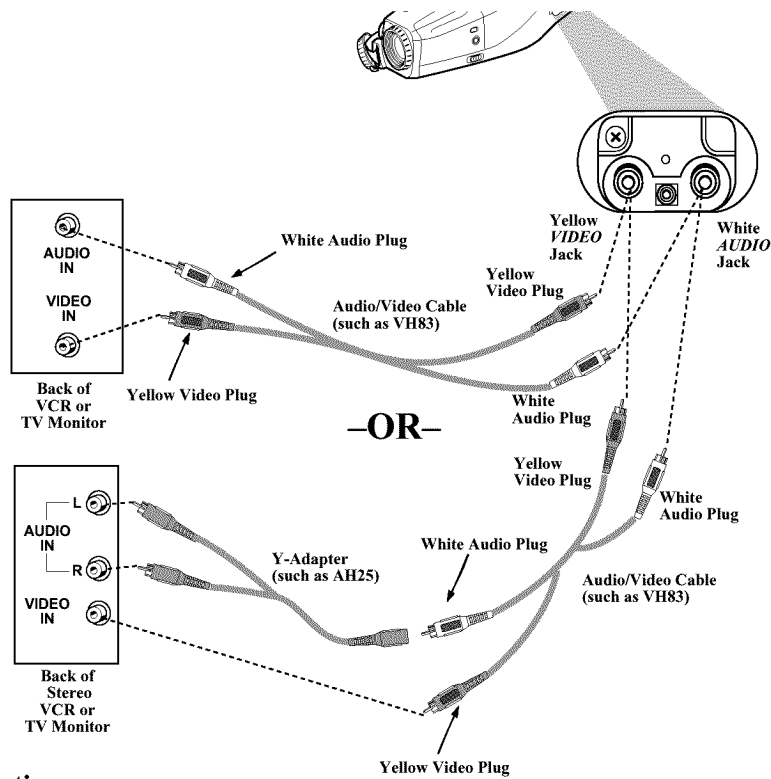

Installation

1. Attach the white plug on one end of the audio/video cable to the *AUDIO IN* jack on the TV (or VCR).
2. Attach the yellow plug to the *VIDEO IN* jack on the TV (or VCR).
3. Attach the white plug on the other end of the audio/video cable to the *AUDIO* jack (located under the small cover) on the side of the camcorder.
4. Attach the yellow plug to the yellow *VIDEO* jack on the camcorder.

Notes: If your cable does not have white and yellow plugs, attach the same color to the audio jacks.

If your TV (or VCR) has stereo *AUDIO IN* jacks, attach the plug to the one labeled *MONO*. If one is not labeled *MONO*, you need a Y-adapter, such as AH25, shown on page 47 to hear both channels.

Playback

Playback Operation and How to Copy Tapes on the VCR

- Camcorder connected directly to TV: Turn on the TV and tune it to the video input channel.
 - Camcorder connected to VCR that is already connected to TV: Turn on VCR and place it in the “line” or “camera mode”. (If your VCR does not have a “line” or “camera mode”, consult the VCR owner’s manual.) Operate the TV as you normally do to see the signal coming from the VCR.
- Press and hold the small button on the *CAMERA/OFF/VCR* switch while you slide it to *VCR*.
Note: The camcorder only plays back tapes recorded in the SP speed.
- Press *PLAY*.
 - During playback, use the playback features on page 39.
- To copy what the camcorder is playing, place a blank cassette in the VCR, and press the VCR’s *RECORD* button.
Note: Make sure the memory-stop feature is turned off (press *DISPLAY*) or the camcorder will enter play-pause when the counter reaches *0000M*.
- Press *STOP/EJECT* when you are finished.

Viewing What the Camcorder is Seeing (or Recording)

- Camcorder connected directly to TV: Turn on the TV, and tune it to the video input channel.
 - Camcorder connected to VCR that is already connected to TV: Turn on VCR and place it in the “line” or “camera mode”. (If your VCR does not have a “line” or “camera mode”, consult the VCR owner’s manual.) Operate the TV as you normally do to see the signal coming from the VCR.
- Press and hold the small button on the *CAMERA/OFF/VCR* switch while you slide it to *CAMERA*.
Note: Turn the TV’s volume down to prevent a high-pitched squeal caused by feedback.
- Press the *REC/PAUSE* button to begin recording. You can watch what the camcorder is seeing (or recording) on the TV screen.

Caution: The unauthorized recording of copyrighted material may infringe the rights of others.

Playback

Playback on a TV Without Audio/Video Inputs

To connect your camcorder to a TV without audio/video inputs, you need an optional CRF95 RF output adapter and an optional coaxial RF cable, such as VH82 or VH90 *shown on page 47*. If your TV has audio and video inputs (or is connected to a VCR), *refer to pages 40-41*.

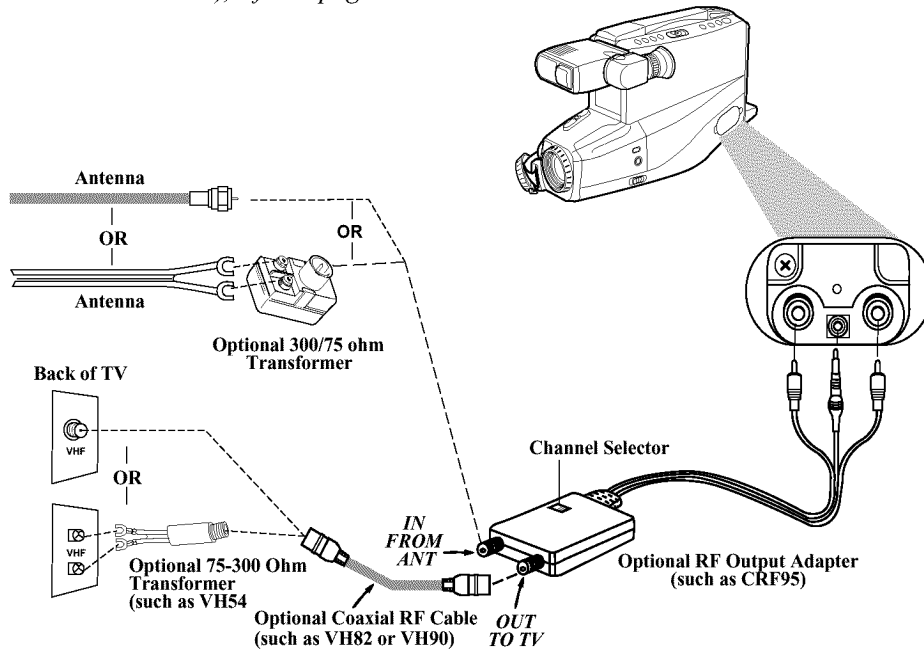

Installation

1. Disconnect the VHF antenna from your TV. Connect the antenna to the *IN FROM ANT* connector on the RF output adapter if you are going to leave the adapter connected to the TV.

Note: If your VHF antenna is the flat twin-lead type attached by two screws, you need an optional 300/75 ohm transformer.

2. Attach one end of the optional coaxial RF cable to the *OUT TO TV* connector on the adapter, and attach the other end to the VHF input on your TV *as shown*.

Note: If your TV has 300 ohm screw terminals, you need a 75/300 ohm transformer, such as VH54, *shown on page 47*.

3. Attach the RF output adapter's yellow plug to the *VIDEO* jack, the small plug to the *RF DC OUT* jack, and the white plug to the *AUDIO* jack located under the small cover on the side of the camcorder.

Playback

Playback Operation

1. Set the *CH3/CH4* switch on the RF output adapter to *CH3* or *CH4*.
2. Turn on the TV, and tune it to the same channel you selected with the RF output adapter's *CH3/CH4* switch.
3. Press and hold the small button on the *CAMERA/OFF/VCR* switch while you slide it to *VCR*.
4. Press *PLAY* on the camcorder.
 - During playback, use the playback features *described on page 39*.
5. Press *STOP/EJECT* on the camcorder when you are finished.

Viewing What the Camcorder Is Recording

1. Turn on the TV and tune it to channel 3 or 4. Turn the TV's volume down to prevent a high-pitched squeal caused by feedback.
2. Set the *CH3/CH4* switch on the RF output adapter to the same channel you selected on the TV.
3. Press and hold the small button on the *CAMERA/OFF/VCR* switch while you slide it to *CAMERA*.
4. Press the *REC/PAUSE* button to begin recording. You can watch what the camcorder is seeing (or recording) on the TV screen.

Normal TV Viewing

For normal TV viewing, leave the RF output adapter hooked up to the TV. Disconnect the adapter's plug from

the camcorder or turn the camcorder's power off.

Note to Cable TV Installer

This reminder is provided to call your attention to Article 820-40 of the National Electrical Code (Section 54 of Canadian Electrical Code, Part I), that provides guidelines for proper grounding and, in particular, specifies that the cable ground shall be connected to the grounding system of the building as close to the point of cable entry as practical.

Travel and Recording Tips

Travel Tips

- Write down your camcorder's serial number and keep it separate from the camcorder when traveling. If your camcorder is lost or stolen, you will be able to identify it.
- Use extra care when you use your camcorder or accessories at a beach or pool. Spray, sand, and dust should be avoided. If your lens has been exposed to the elements, clean it only with proper lens cleaning supplies.
- Make sure you have any adapters that you might need before taking your camcorder to other countries. Consult your dealer for advice.
- Carry your camcorder in a carrying case when traveling. *See the next page for a carrying case designed for your camcorder.* An ordinary suitcase or carry bag does not offer the protection your camcorder needs. Treat your camcorder as carry-on luggage to protect it from rough handling.

Recording Tips

- Try to make sure indoor scenes are well-lit. This improves picture quality and color reproduction.
- Do not move the camcorder rapidly from side-to-side while recording. A steady, gradual "pan" avoids blurring and "jitter."
- Use the viewfinder to make sure the camcorder is level while recording so that your scenes won't appear "tilted."
- Do not bump or tap the camcorder's microphone while recording so that your scenes won't appear tilted.
- Include close-ups of individuals when taping family outings or group functions.
- Fading in and out of scenes makes your videos appear more professional.
- Be aware of video and audio backgrounds. Background details barely noticed while you are taping may show up as visual "clutter" on your recording. Background noises (especially TV sets, radios, household appliances, traffic sounds, etc.) can detract from the sound you want to record.
- Avoid long "still" shots of landmarks and scenic attractions. Recordings are more interesting if they include people and details. "Local color" will give travel videos lasting appeal. Consider recording a familiar or landmark scene from an unfamiliar vantage point.

Optional Accessories

We invite you to take a look at some great ideas for sparking creativity and adding to the fun of using your VHS camcorder. The following pages have a selection of accessories to help make your memorable moments look and sound even better.

These accessories are designed to make the process of recording and watching your videos more enjoyable.

To order accessories, contact your local Dealer.

If a dealer is not nearby, all accessories are available through toll-free ordering or by using the order form *on page 49*.

AC202 Soft Carrying Case

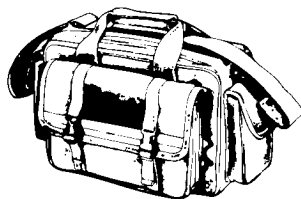

This case provides protection and utility for full size camcorders and most accessories. It is constructed of rugged nylon fabric for years of reliable service. Three outside pockets provide ample accessory storage with mesh-covered lens filter compartment and built-in holders for memo pads, pens, and other accessories. The hand grip and adjustable shoulder strap allow for convenient, comfortable transportation of the camcorder.

DCC096 DC Car Cord Adapter

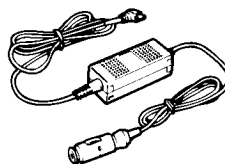

Do not use any other car cord with this camcorder.

This car cord adapter enables you to operate your camcorder from your car, truck, or RV by plugging the car cord directly into the vehicle's cigarette lighter socket. The DCC096 is designed specifically to convert power from a 12-volt battery to a 9.6-volt output.

Optional Accessories

EP096FS and EP096FL Rechargeable Batteries

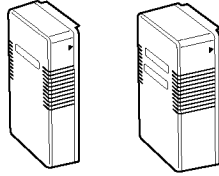

These rechargeable lead-acid batteries are designed specifically for long life. The EP096FS is a 1-hour battery. The EP096FL powers your camcorder twice as long as the EP096FS (depending on how much you turn the camcorder on and off and use zoom and pause). Both can be recharged with the AC adapter/charger that came with your camcorder.

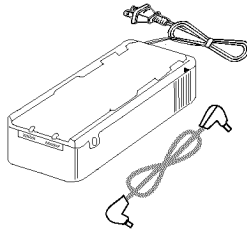

CPS014 AC Battery Charger

The CPS014 battery charger plugs directly into an AC outlet and charges the EP096FS and EP096FL camcorder batteries. Because the CPS014 operates on 100-240 Volts, 50/60 Hz, you can use it virtually anywhere in the world. A plug adapter might be required in some countries.

All specifications and descriptions of accessories are subject to change without notice.

Using the Optional AC093 Tripod

Mounting the camcorder on a tripod, such as AC093, keeps the camcorder steady and produces excellent video results.

This tripod's fluid-effect head provides smooth camera pan and tilt. The quick-release mount makes it easy to attach or remove the camcorder. The grooved, tubular 3-section leg design folds down to 24" when not in use. Rubber feet allow for sure footing and built-in retractable leg spikes eliminate the need for removing the feet.

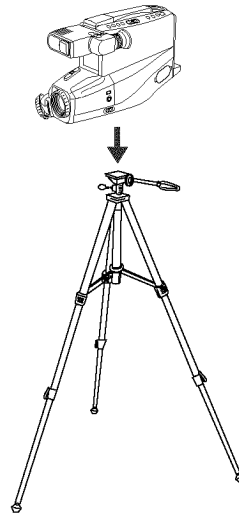

Cautions: Before using a tripod, make sure it is stable enough to hold the camcorder without falling over. Do not transport the camcorder attached to the tripod.

When attaching your camcorder to a tripod, be careful not to force the tripod screw into the camcorder's tripod mounting hole.

The tripod screw should not protrude into the camcorder more than approximately three-eighths (3/8) inch. Forcing the screw could damage the mounting hole on the bottom of the camcorder.

Optional Accessories

CRF95 RF Output Adapter

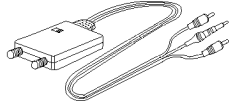

This RF output adapter is used with a coaxial RF cable, such as VH82 or VH90, to connect your camcorder to a standard TV (one without audio/video inputs) for playback. If your antenna cable is the flat twin-lead type attached by two screws, you need a 300-to-75 ohm transformer. If your TV has 300 ohm antenna screw terminals, you need an optional 75-to-300 ohm transformer such as VH54.

Coaxial RF Cables

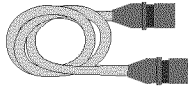

VH82 (6-ft)
VH90 (12-ft)

These RF cables are used with the RF output adapter to connect your camcorder to a standard TV (one without audio/video input jacks) for playback. If your TV has 300 ohm antenna screw terminals, you need an optional 75-to-300 ohm transformer, such as VH54. If your antenna cable is the flat twin-lead type attached by two screws, you need an optional 300-to-75 ohm transformer.

VH54 Cable Transformer

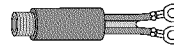

This 75-to-300 ohm transformer is used to connect a standard 75-ohm antenna cable (such as VH82 or VH90) to the 300 ohm screw terminals on a TV.

VH83 Audio/Video Cable

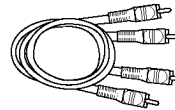

This six foot audio/video cable can be used to connect the camcorder to a TV monitor or VCR for tape playback or copying tapes.

AH25 Y-Adapter



This Y-adapter allows you to connect your camcorder's mono audio cable to a stereo TV or VCR.

All specifications and descriptions of accessories are subject to change without notice.

Optional Accessories

Remove the Lens Hood

The lens hood can be removed so you can attach optional accessories, such as wide-angle lens, lens extenders, or lens filter kits.

To Attach an Accessory Lens

1. Attach the lens cap over the lens hood.
2. Turn the lens cap and hood counterclockwise with the palm of your hand to remove them.
3. Turn the accessory lens clockwise into the camcorder's lens. Make sure the lens is tightened firmly, but do not over tighten.

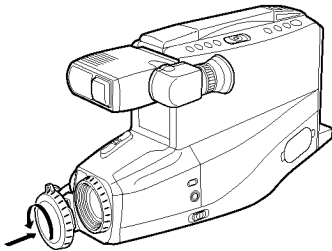

2. Turn the lens cap and hood counterclockwise with the palm of your hand to remove them.

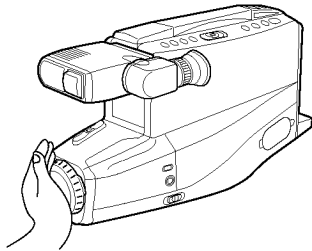

Caution: Do not grasp the end of the lens hood.

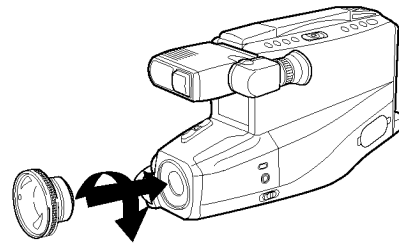

All specifications and descriptions of accessories are subject to change without notice.

Accessory Order Form

Order Form for Camcorder Model CC4271				
Description	Part No.	Price	Qty.	Total
Deluxe Tripod	AC093	\$ 59.95		
Soft Camcorder Case	AC202	\$ 49.95		
Y-Adapter	AH25	\$ 2.95		
AC Adapter/Charger (100-240V)	CPS014	\$219.95		
RF Output Adapter	CRF95	\$ 69.95		
Car Cord Adapter	DCC096	\$ 49.95		
Rechargeable Battery (Extended)	EP096FL	\$ 79.95		
Rechargeable Battery (Standard)	EP096FS	\$ 69.95		
75-300 Cable Transformer	VH54	\$ 2.95		
Coaxial RF-Cable	VH82	\$ 6.95		
Audio/Video Cable	VH83	\$ 5.95		
Coaxial RF-Cable	VH90	\$ 7.95		
Replacement Bulb (4 watt) for Built-in Light	221111	\$ 12.95		
Shoulder Strap	227327 or	\$ 12.95		
	241305	\$ 12.95		
AC Adapter/Charger (Supplied) and DC Cable	241044	\$169.95		
	241308	\$ 13.65		
Total Merchandise				\$ _____
Sales Tax				\$ _____
We are required by law to collect the appropriate sales tax for each individual state, county, and locality to which the merchandise is being sent.				
Shipping and Handling				\$ 5.00
Total Amount Enclosed				\$ _____
Use VISA, MasterCard, or Discover. Money order or check must be in U.S. currency only. No COD or cash. Prices are subject to change without notice.				

Detach Here

Please complete other side also

Accessory Order Form

Charge your order on your VISA, MasterCard,
or Discover Card by filling in below

USE YOUR CREDIT CARD

IMPORTANT: Copy complete account number from your VISA card

Expiration date:



IMPORTANT: Copy complete account number from your MasterCard



Copy Number above your name on MasterCard Expiration date:

IMPORTANT: Copy complete account number from your Discover Card



Expiration date:

AUTHORIZED SIGNATURE

Prices are subject to change without notice.

Print or type your name and
address clearly.

A complete and correct order will
save you days of waiting.

↓

Name: _____

Street: _____

_____ Apt: _____

City: _____

State: _____ Zip: _____

Please make sure that both sides of this form have been filled out completely.

- Allow 4 weeks for delivery.
- All accessories are subject to availability.

Detach Here 

Accessory Order Form

To order accessories, contact your local Dealer.

If a dealer is not nearby, you can also follow the directions below to order by telephone or direct-by-mail.

United States and Canada Orders

To place your order by phone, have your Visa, MasterCard, or Discover card ready and call the toll-free number listed below between 8 AM and 10 PM (EST) Monday through Friday or between 9AM and 5PM (EST) Saturday.

Use this number only to place an order for accessory items listed on this order form.

1-800-338-0376

To place your order by mail, detach and mail the completed order form with credit card information, money order, or check in U.S. currency (made payable to Thomson Consumer Electronics, Inc.) to the following address:

Video Accessories
PO Box 8419
Ronks, PA 17573

Trouble Checks

If you're having trouble with your camcorder, you probably can correct the problem yourself. Before you take your camcorder to an Authorized RCA Camcorder Service Center or call a service person, use the chart below. Find the problem and try the adjustment(s) that is listed to the right.

If service should be necessary, read your warranty to find out what is covered and how to get service.

Trouble	Checks and Adjustments
No power	<ul style="list-style-type: none"> • Set the <i>CAMERA/OFF/VCR</i> switch to <i>CAMERA</i> or <i>VCR</i> to turn on the camcorder. • If using battery, it may need to be recharged. • If using AC adapter/charger, make sure it is plugged into a working outlet.
Won't record or play back	<ul style="list-style-type: none"> • If using AC adapter/charger, make sure it is plugged into a working outlet. • Make sure <i>CAMERA/OFF/VCR</i> switch is set to correct position for desired operation. • There might not be a cassette in the camcorder. • Try ejecting and reinserting the cassette. • The cassette tape might be broken, try another cassette. • You might have reached the end of the cassette, try rewinding it. • Moisture condensation might cause the tape to stick to the headwheel and damage the headwheel or tape. Give the camcorder 2 or 3 hours to reach a stable temperature before reinserting a cassette.
Won't play back	<ul style="list-style-type: none"> • <i>CAMERA/OFF/VCR</i> switch must be set to <i>VCR</i>.
Won't record	<ul style="list-style-type: none"> • Safety tab removed. <i>See page 20.</i> • <i>CAMERA/OFF/VCR</i> switch must be set to <i>CAMERA</i>.
No picture	<ul style="list-style-type: none"> • Remove lens cap.
Camcorder turns off	<ul style="list-style-type: none"> • Set the <i>CAMERA/OFF/VCR</i> switch to <i>OFF</i> and then to <i>CAMERA</i> or <i>VCR</i> to turn back on. If camcorder is left in record-pause or play-pause for several minutes, it turns off to prevent tape wear.

Trouble Checks

Trouble	Checks and Adjustments
Sound is too low or distorted	<ul style="list-style-type: none"> • Subject was too far from camcorder.
Tape stops during rewind or fast forward or will not operate during rewind or fast forward	<ul style="list-style-type: none"> • Whenever the tape counter appears, the camcorder will stop rewinding (or fast forwarding) when counter reads <i>0000M</i>. Press <i>REW/REVIEW</i> or <i>F.FWD</i> again to continue rewinding or fast forwarding, or press <i>DISPLAY</i> to remove the tape counter. • Make sure titler graphics do not appear in viewfinder. Press <i>TITLER</i> button to remove.
Camcorder remains in play-pause mode	<ul style="list-style-type: none"> • Press <i>REC/PAUSE</i> to return to normal playback.
Poor auto-focus operation	<ul style="list-style-type: none"> • Lens is smudged and image appears unfocused. • Eyepiece focus control is misadjusted.
Viewfinder displays are out of focus, too dark or too bright	<ul style="list-style-type: none"> • Eyepiece focus control is misadjusted. <i>See page 24.</i> • Adjust the <i>BRIGHT</i> control on the bottom of the viewfinder. <i>See page 25.</i>
Picture quality is poor during playback	<ul style="list-style-type: none"> • Tape was recorded on a different camcorder or VCR. If the picture contains black-and-white streaks, press one of the tracking buttons to correct it. <i>See page 39.</i> • Camcorder only has one speed (<i>SP</i>). If the tape was recorded at a different speed, it cannot be played back on this camcorder.
Date and/or time or title are recorded on tape	<ul style="list-style-type: none"> • Displays are recorded on tape whenever they appear in the viewfinder. Remove them from the viewfinder when recording. <i>See pages 22-23.</i> • When  <i>DATE</i> or <i>TITLE</i> is selected, the display is automatically recorded when you begin recording or change the cassette. <i>See pages 22-23.</i> • Title is recorded whenever it appears in the viewfinder. Press the <i>TITLER</i> button to remove the title from the viewfinder. <i>See page 37.</i>

Trouble Checks

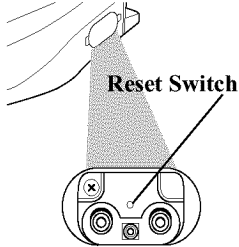
Trouble	Checks and Adjustments
Date and/or time are incorrect	<ul style="list-style-type: none"> • Date or time may need to be set. <i>See page 22.</i> • Clock lithium cell battery may need recharging. <i>See page 23.</i>
Camcorder does not turn on and/or function buttons will not operate	<ul style="list-style-type: none"> • Remove the power source. After one minute press the reset switch gently using a nonmetallic pointed item, such as a toothpick, until you feel a click. This resets the camcorder to the factory settings and erases the date, time, and custom settings. Wait for at least one minute after resetting the camcorder to attach a power supply. 
Bright, crystal-shaped spots appear in viewfinder	<ul style="list-style-type: none"> • Sunlight is directly entering the lens.
Colored bright spots appear in viewfinder	<ul style="list-style-type: none"> • Black spots or bright spots of light (red, green, or blue) might appear in the viewfinder. These spots are not recorded on the tape and are not due to a defect in the unit.
Rechargeable battery runs down sooner than expected	<ul style="list-style-type: none"> • Lead-acid batteries must be kept charged. Charge your battery before and after every use and at least every six months. • Battery run times are measured when the camcorder is recording continuously. To check your battery; charge it completely, aim the camcorder at a clock, and record the clock. When the camcorder stops recording, play the last part of the tape and check the time on the clock. A one-hour battery should give you about 60 minutes of recording time. In practical use, a fully charged battery might not record for 60 minutes because the battery uses power when you pause the recording and uses extra power when you zoom.

Information to User

This equipment has been tested and found to comply with the limits for a Class B digital device pursuant to Part 15 of the FCC Rules. These limits are designed to provide reasonable protection against harmful interference in a residential installation. This equipment generates, uses, and can radiate radio frequency energy and, if not installed and used in accordance with the instructions, may cause harmful interference to radio communications. However, there is no guarantee that interference will not occur in a particular installation. If this equipment does cause harmful interference to radio or television reception, which can be determined by turning the equipment off and on, the user is encouraged to try to correct the interference by one or more of the following measures:

- Reorient or relocate the receiving antenna.

- Increase the separation between the equipment and receiver.
- Connect the equipment into an outlet on a circuit different from that to which the receiver is connected.
- Consult the dealer or an experienced radio/TV technician for help.

Alterations or modifications carried out without appropriate authorization may invalidate the user's FCC right to operate the equipment.

This Class B digital apparatus meets all requirements of the Canadian Interference — Causing Equipment Regulations.
Cet appareil numérique de la classe B respecte toutes les exigences du Règlement sur le matériel brouilleur du Canada.

Care and Maintenance

Clean the Camcorder

To clean the camcorder's exterior, remove any power source connected to the camcorder and gently wipe it with a clean soft cloth.

Caution: Use of strong cleaning products, such as those containing alcohol or benzine, might damage the camcorder.

Clean the Camcorder's Lens

To clean the camcorder's lens, blow it with a blower brush, and then gently wipe the lens with cleaning tissue and commercially prepared cleaning solution designed for use on camera lens. Improper cleaning might scratch the lens.

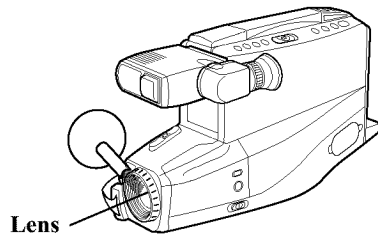

Caution: Do not touch the lens with your fingers. The oil from your skin can damage the lens.

Clean the Camcorder's Viewfinder

You can remove the viewfinder eyepiece for cleaning.

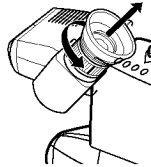

1. Turn the eyepiece counterclockwise and pull it out.

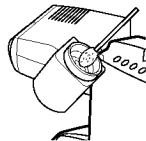

2. Gently use a cotton swab or blower brush to remove the dust.



3. Reattach the eyepiece by aligning the reference marks and turning the eyepiece clockwise until it clicks into place.

Care and Maintenance

Proper Care and Storage

- Keep dust and grit from entering the camcorder's cassette door. Dust and grit are abrasive and cause excessive wear to both the camcorder's recording/playback heads and cassettes.
- Always place the lens cap back on the camcorder when it is not in use.
- Before handling your camcorder, make sure your hands and face are free from any chemical products such as suntan lotion, as it might damage the finish.
- The camcorder might be damaged by improper storage or handling. Do not subject the camcorder to swinging, shaking, or dropping.
- Do not store the camcorder in temperatures below -22°F (-30°C) or above 149°F (65°C).
- When the camcorder is not in use, always remove the cassette and AC adapter/charger or battery.
- Retain the original carton for future storage or shipping purposes.

Things to Avoid

- Do not attempt to disassemble your camcorder. There are no user-serviceable parts inside.
- Avoid operating your camcorder immediately after moving it from a cold location to a warm location. Give the camcorder 2 to 3 hours to reach a stable temperature before inserting a cassette. When the camcorder is moved from cold to warm, condensation might cause the tape to stick to the headwheel and damage the headwheel or tape.
- Do not aim your camcorder at the sun or other bright objects.
- Do not leave your camcorder in direct sunlight for extended periods of time. The resulting heat buildup might permanently damage the camcorder's internal parts.
- Do not operate the camcorder in extremely humid environments.
- Do not operate the camcorder near the ocean as salt water or salt water spray might damage the internal parts of the camcorder.
- Do not operate the camcorder for extended periods in temperatures below 40°F (4°C) or above 95°F (35°C).
- Do not expose the camcorder or adapter/charger to rain or moisture. If any component becomes wet, turn off the power and take the unit to an Authorized RCA Camcorder Service Center.
- Do not use an adapter/charger or batteries other than the ones specified for the camcorder. Use of the wrong accessories might cause damage to the camcorder.

Specifications

General

Power requirement: 9.6VDC
Power consumption:
Viewfinder on: 7.5 watts
Weight: 4.4 lbs. (2kg)

Dimensions – Including Viewfinder:

4-1/4" (W) x 8-3/8" (H) x 13-1/8" (D)
108 (W) x 213 (H) x 334 (D) mm

Video Recorder Section

Format: VHS
Record/playback system:
Two video record/playback heads
Video signal: EIA standard
NTSC color

Viewfinder

0.55" color viewfinder

Camera Section

Scanning: 525 lines/60 fields/
30 frames
Image Sensor: 1/4" CCD Imager
Lens: F1.4
16:1 (4-64 mm) power zoom lens
Diameter: 46 mm

AC Adapter/Charger

Power requirement: 120 V,
50/60 Hz.
Power consumption: 24 watts
Weight: .85 lbs. (390g)
Dimensions:
6"(W) x 1.7"(H) x 2.7"(D)
152 (W) x 43 (H) x 69 (D) mm

Tripod Mount

One 1/4" x 10 threaded hole

Customer Assistance and Service

You can reach Thomson at the following number:

800-283-6503

(Toll free inside U.S.A.)

Our toll-free Camcorder number operates from 8 a.m. to 5 p.m., CST Monday – Friday for U.S. customers only

Thomson provides a toll-free telephone number to help you with any problems you may encounter with your camcorder. Many can be diagnosed over the phone, and if necessary, repair or replacement will be arranged. Please have your camcorder model/serial number and date of purchase ready when you call. If your unit is out of warranty, we will quote the cost of a repair or replacement unit to you.

Returning equipment to Thomson for repair or exchange

If we are unable to resolve your problem over the phone, we will gladly service your unit or exchange it for a new or, at our option, refurbished camcorder. Refer to the limited warranty on the next page to learn about your specific rights and responsibilities.

Always consult Thomson and get a Return Authorization number before returning anything! Obtain a Return Authorization (RA) number from the telephone representative before returning your equipment to avoid delays, accounting errors, or even loss of your unit.

Important information to customers who ship defective equipment to Thomson Consumer Electronics

The Thomson representative who authorized the return of your equipment will give you an RA number over the phone. They will also provide you with instructions on where and how to return your Camcorder. Write the number in large, clear characters on the outside of the box. To avoid confusion and misunderstandings, shipments without an RA number clearly visible on the outside of the box will be returned to you at your expense.

Include a brief note describing the problem and any conversations about the problem you have had with Thomson personnel.

Include your name, address and model/serial number of your Camcorder. These numbers

are located on the bottom of your unit.

If your Camcorder is within the warranty period, please provide a copy of the bill of sale to verify purchase date. Use the original box and packing material to protect the equipment from damage in shipment.

For your protection, insure all shipments for full replacement value and use a reliable shipper. Thomson assumes no responsibility for warranty shipments from the customer to the factory if not shipped in the manner prescribed by Thomson.

Limited Warranty

What your warranty covers:

- Any defect in materials or workmanship.

For how long after your purchase:

- 90 days for labor charges.
- One year for parts.

The warranty period for rental units begins with the first rental or 45 days from date of shipment to the rental firm, whichever comes first.

What we will do:

During the initial 90 days

- Exchange your camcorder with a new or refurbished unit, or repair your camcorder. The option will be ours. There will be no cost to you.

After the 90 days and within one year

- Exchange your camcorder with a new or refurbished unit, or repair your camcorder. The option will be ours. Parts will be provided at no charge, but you will be responsible for the cost of labor required for the repair.

How you get service:

- Call 1-800-283-6503 and have your unit's date of purchase and model/serial number ready. The model/serial number information is on the bottom of your camcorder.
- A representative will troubleshoot your problem over the phone. If the representative determines that you should receive a replacement unit, you will be provided with a Return Authorization (RA) number and the location of a nearby exchange point if one exists. No returns will be accepted without the RA number.

To receive a replacement Camcorder before you return yours:

If you are located near an exchange point:

1. We will send a replacement unit to the exchange point next business day delivery in the continental U.S.A.

2. The exchange location will notify you of its arrival.
3. Take your unit, excluding all accessories, and your evidence of purchase date, such as a bill of sale, to the exchange location and you will be provided the new or refurbished unit.
4. If the repairs were covered by your warranty, you will not be billed.

If you are *not* located near an exchange point:

1. Provide your Discover, MasterCard, or Visa account number and expiration date to our phone representative. This is for security purposes. If we receive your unit, excluding all accessories, within 14 days from the date you were provided the RA number, only items not covered by warranty will be charged to your account. **IF YOUR UNIT IS NOT RECEIVED WITHIN 14 DAYS, THE SUGGESTED RETAIL VALUE OF THE CAMCORDER WILL BE CHARGED TO YOUR CREDIT CARD.** This amount will be credited if the unit is subsequently received.
2. We will send you a replacement unit next business day delivery in the continental U.S.A.
3. You will receive an invoice packed with the replacement product, but will not be charged for the unit portion of the invoice amount if we receive your unit within 14 days from the date you were provided the RA number. Any labor and parts charges not covered by our warranty will be included and charged against your account.
4. Ship the unit back to us, excluding all accessories, using the replacement unit's carton. Shipping instructions will be included in the carton along with your RA number which will allow you to easily ship the unit back to us. **Make sure you insure your shipment in case of damage or loss.** Include with the shipment:

Limited Warranty

- Evidence of purchase date, such as a bill of sale, to verify your unit's warranty eligibility.
- A brief note describing your camcorder's problem.
- Your name, address and phone number.

Return transportation, storage, handling, and insurance costs are your sole responsibility. We accept no liability in case of damage or loss.

To receive a replacement unit after we have received your unit:

1. **Write the RA number on the outside of the carton used to return the unit. Make sure you insure your shipment in case of damage or loss.**
2. Carefully pack the unit, excluding all accessories, using the original box and packing material if possible.
3. Include with the shipment:
 - Evidence of purchase date, such as a bill of sale, to verify your unit's warranty eligibility.
 - A brief note describing your camcorder problem.
 - Your name, address and phone number.

Return transportation, storage, handling, and insurance costs are your responsibility. We accept no liability in case of damage or loss.

4. The representative will advise the address to mail a cashier's check or money order for payment if there are any out of warranty labor or parts charges and you elect not to use your credit card.
5. Upon receipt of your product, a new or refurbished unit will be shipped to you next business day delivery in the continental U.S.A.

To have your Camcorder repaired by an Authorized RCA Camcorder Service Center:

- Check with your dealer or call 1-800-336-1900 for the Authorized RCA Camcorder Service Center nearest you.

- Take your unit to the Authorized RCA Camcorder Service Center of your choice.
- Show the Authorized RCA Camcorder Service Center representative evidence of purchase date, such as a bill of sale.
- Pick up your camcorder when repairs are complete.

What your warranty does not cover:

- Adjustment of customer controls.
- Damage from misuse or neglect.
- A unit that has been modified or incorporated into other products or is used for institutional or other commercial purposes.
- Batteries for remote control and clock.
- Cleaning of video/audio heads.
- Camcorders purchased or serviced outside the U.S.A.
- Return transportation, storage and handling costs of your unit, including insurance for loss or damage.
- Acts of God, such as but not limited to lightning damage.

Product Registration:

- Please complete and mail the Product Registration Card packed with your camcorder. It will make it easier to contact you should it ever be necessary. The return of the card is not required for warranty coverage.

How State Law relates to warranty:

- This warranty gives you specific legal rights and you also may have other rights that vary from state to state.

If you purchased your camcorder outside the United States:

- This warranty does not apply. Contact your dealer for warranty information.

Index

+ and - buttons 9, 35, 36

A

Accessories
 included 3
 optional 45
 order form 49
Adapter/charger
 accessory 3
 charging battery 15
 using 4, 14
AE focus indicators 26, 29
Assistance 1, 3
Assistance, customer 59
Attach accessory lens 48
AUDIO and VIDEO jacks 9, 40, 42
Auto focus 29
Auto Shot™ feature 28

B

Battery
 accessory 3
 attaching and removing 16
 care 18
 charging 15
 safety precautions 18
 storage 18
 using 15
BATTERY EJECT button 10, 16
Battery level indicator 17, 26, 27
BRIGHT control 6, 10, 25, 38, 39

C

Cable TV installer note 43
Camcorder
 cleaning 56
 turn on 5
Camcorder's operating controls 9
Camera edit feature 29

CAMERA/OFF/VCR switch
 5, 8, 9, 12, 16, 17, 19, 22, 23, 28,
 29, 34, 35, 36, 37, 38, 39, 41, 43
Car cord adapter, optional 19
Care and maintenance
 cleaning the camcorder 56
 cleaning the lens 56
 cleaning the viewfinder 56
 proper care and storage 57
 things to avoid 57
Care and storage
 camcorder 57
 cassette 21
Cassette care and storage 21
Cassette compartment 38
Cassette door 10
Cassette holder 21
Cassettes
 insert and remove 21
 video 20
Cautions i
Charging clock battery 23
Chart of characters in titler 36
Checks, trouble 52
Cleaning the camcorder 56
Cleaning the camcorder's lens 56
Cleaning the viewfinder 56
Clock battery
 charging 23
Color enhancement light 7, 9, 12
Contents 1
Copy tapes 41
Customer assistance and service 59

D

DATE/TIME button 9, 22, 23, 27, 37
DC cable 3, 14, 15, 16, 19
DC IN 9.6V jack 10, 14, 19
Design specifications 58
DISPLAY button
 9, 17, 26, 27, 28, 30, 31, 34, 41
Displays, viewfinder 26

Index

E

EDIT-ADV button 9, 35, 36
Electronic indexing 30
Erase protection 20
Eyepiece 38
Eyepiece focus control 6, 10, 24, 39

F

F.FWD (fast forward) button
9, 22, 28, 29, 34, 35, 38, 39
FADE button 9, 32
Fade feature 32
Fade indicator 26, 32
Fast-forwarding indicator 26
First time operation 3
Focus
auto 29
macro 29

H

Handstrap 4, 10
Head cleaning 20

I

Important safety information i
INDEX indicator 26, 30
Indicators
AE focus 26, 29
battery level 17, 26
fade 26, 32
fast-forwarding 26
INDEX 26, 30
NO TAPE 27
pause 26
REC 7, 26
record-pause 7
rewind 26
status 26

steady pix 26, 33
TAPE 27
tape counter 27, 34
TAPE END 27, 30
tape remaining 27, 30
ZOOM 27, 31
zoom level 27, 31
Information to user 55
Insert and remove cassettes 21

L

Lens 9
Lens cap 4, 48
Lens hood 9
removing 48
LIGHT AUTO/OFF/ON switch 7, 9, 12
Light bulb, replace 13
Light, color enhancement 12
Limited warranty 60

M

Macro focus 29
Memory-stop feature 27, 34
Microphone 9, 28

N

NO TAPE indicator 27

O

Operating controls 9
Optional accessories 45
Order form, accessories 49

Index

P

- PLAY button 8, 9, 28, 29, 39, 41, 43
- Playback features
 - stop-action pause 39
 - tape counter 34
 - tape positioning 39
 - tracking 39
 - visual searching 39
- Playback, first 8
- Playback on a TV without audio/video
 - inputs 42
- Playback on TV (or VCR) with audio/video
 - in jacks 40
- Playback speed 20
- Powering your camcorder
 - using adapter/charger 14
 - using battery 15
 - using optional car cord adapter 19
- Problem solving 52
- Product registration i

Q

- Quick review feature 29

R

- REC indicator 7, 26
- REC/PAUSE button
 - 7, 8, 10, 32, 34, 37, 38, 39, 41, 43
- Record-pause indicator 7
- Recording speed 20
- Recording tips 44
- Registration i
- Remove lens hood 48
- Replace the light bulb 13
- RESET button 9, 34
- Reset switch 9
- REW(rewind)/REVIEW button
 - 8, 9, 22, 28, 29, 34, 35, 38, 39
- Rewinding indicator 26

- RF DC OUT jack 9, 42
- RF output adapter, optional 42

S

- Safety information i
- Safety precautions, battery 18
- Safety tab 20
- Searching during playback 39
- Shoulder strap 3
 - attaching 11
- Shoulder strap attachment rings 10, 11
- Solving problems 52
- SP speed 20, 38
- Specifications 58
- Speed
 - recording and playback 20
- Status indicators 26
- STEADY PIX button 9, 26, 33
- Steady pix feature 33
- Steady pix indicator 33
- Stop-action pause 39
- STOP/EJECT button
 - 5, 8, 9, 17, 21, 22, 34, 35, 38, 39, 41, 43

T

- Table of contents 1
- Tape
 - inserting 5
- Tape copying 41
- Tape counter 27, 34
- TAPE END indicator 27, 30
- TAPE indicator 27
- Tape positioning 39
- Tape remaining display 27, 30
- Tape warnings 27
- Tape wheel 21
- Things to avoid 57
- Time and date
 - correct 22
 - display 22, 27
 - recording 23
 - setting 22

Index

Tips
 recording 44
 travel 44

Title
 record 23

Titler 35
 chart of characters 37
 correct an error 36
 create a title 36
 record on a tape in camcorder 37
 record while copying a tape 37

TITLER button 9, 35, 36, 37

Tracking 39

TRACKING buttons 10, 38, 39

Travel Tips 44

Tripod
 optional 46
 using 46

Trouble checks 52

U

Unpack camcorder and accessories 3

V

Videocassettes 20

Viewfinder 6, 10, 24, 25
 adjust for viewing 24
 BRIGHT control 25
 displays 26
 eyepiece focus control 24
 playback 38
 tilt adjustment 25

W

Warnings i

Warnings, tape 27

Warranty, limited 60

Z

Zoom buttons 10, 28, 31

ZOOM indicator 27, 31

Zoom level indicator 27, 31

Zooming 31

 **THOMSON CONSUMER ELECTRONICS**
10330 N Meridian Street
Indianapolis, IN 46290

©1998 Thomson Consumer Electronics, Inc.
Trademark(s)[®] Registered
Marca(s) Registrada(s)
Printed in Japan
15331680
QR19423