

Owner's Guide

Projection Television Models
WS-55859, WS-55909,
WS-65869, WS-65909,
and WS-73909

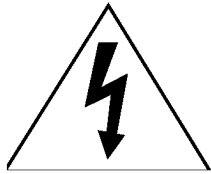



CAUTION

RISK OF ELECTRIC SHOCK
DO NOT OPEN



CAUTION: TO REDUCE THE RISK OF ELECTRIC SHOCK, DO NOT REMOVE COVER (OR BACK).
NO USER SERVICEABLE PARTS INSIDE.
REFER SERVICING TO QUALIFIED SERVICE PERSONNEL.

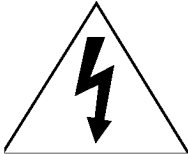

The lightning flash with arrowhead symbol within an equilateral triangle is intended to alert the user of the presence of uninsulated "dangerous voltage" within the product's enclosure that may be sufficient magnitude to constitute a risk of electric shock.



The exclamation point within an equilateral triangle is intended to alert the user to the presence of important operating and maintenance (servicing) instructions in the literature accompanying the appliance.

Warning: To avoid permanently imprinting a fixed image onto your TV screen, please do not display the same stationary images on the screen for more than 15% of your total TV viewing in one week. Examples of stationary images are letterbox top/bottom bars from DVD disc or other video sources, side bars when showing standard TV pictures on widescreen TVs, stock market reports, video game patterns, station logos, web sites or stationary computer images. Such patterns can unevenly age the picture tubes causing permanent damage to the TV. Please see pages 25 and 70 for a detailed explanation.

Note: This equipment has been tested and found to comply with the limits for a Class B digital device, pursuant to part 15 of the FCC Rules. These limits are designed to provide reasonable protection against harmful interference in a residential installation. This equipment generates, uses and can radiate radio frequency energy and, if not installed and used in accordance with the instructions, may cause harmful interference to radio communications. However, there is no guarantee that interference will not occur in a particular installation. If this equipment does cause harmful interference to radio or television reception, which can be determined by turning the equipment off and on, the user is encouraged to try to correct the interference by one or more of the following measures:

- Reorient or relocate the receiving antenna.
- Increase the separation between the equipment and the receiver.
- Connect the equipment into an outlet on a circuit different from that to which the receiver is connected.
- Consult the dealer or an experienced radio/TV technician for help.

CAUTION: To assure continued FCC compliance, the user must use a shielded video interface cable with bounded ferrite cores, when using the VGA input.

Changes or modifications not expressly approved by Mitsubishi could void the user's authority to operate this equipment.

WARNING:

TO REDUCE THE RISK OF FIRE OR ELECTRIC SHOCK, DO NOT EXPOSE THIS APPLIANCE TO RAIN OR MOISTURE.

CAUTION:

TO PREVENT ELECTRIC SHOCK, MATCH WIDE BLADE OF PLUG TO WIDE SLOT, FULLY INSERT.

NOTE TO CATV SYSTEM INSTALLER:

THIS REMINDER IS PROVIDED TO CALL THE CATV SYSTEM INSTALLER'S ATTENTION TO ARTICLE 820-40 OF THE NEC THAT PROVIDES GUIDELINES FOR THE PROPER GROUNDING AND, IN PARTICULAR, SPECIFIES THAT THE CABLE GROUND SHALL BE CONNECTED TO THE GROUNDING SYSTEM OF THE BUILDING, AS CLOSE TO THE POINT OF CABLE ENTRY AS PRACTICAL.

IMPORTANT SAFEGUARDS	4-5
Thank You Letter	8
Unpacking Your New TV	9
Special Features	9
Front Control Panel Functions	12
Back Panel Functions	13
Installation Configurations & NetCommand™ Setup	15
NetCommand™ Supported Devices	16
Connecting to Your New Mitsubishi Bigscreen:	
Antenna or Wall Outlet Cable for Digital Broadcasts	17
Analog Antenna, Wall Outlet Cable, or Cable Box	18
Analog VCR	19
A/V Receiver	20
DVD Player or S-Video VCR or Satellite Receiver	21
External DTV Receiver	22-23
Computer with a VGA Monitor Output	24
IR-Home Theater Control and IR-Repeater	24
IMPORTANT NOTES	25
NetCommand™ Setup	26-35
ViewPoint™ on-screen menu system	38
Device Selection Menu	39
PIP Selection Menu	40
Menu Screens (Overview)	41-42
Setup Menu: Edit Setup and Icon Position	43
Setup Menu: Convergence	44
Setup Menu: Advanced Convergence, Transport Menu and Language	45
Antenna Menu: Antenna, Memorize Channels, Memory and Name	46
Antenna Menu: Super Quick View™ (SQV™)	47
Clock Menu: Auto or Manual Clock Setting	48
Captions Menu: Closed Captions	49
V-Chip Menu: Passcode	50
V-Chip Menu: V-Chip	51
V-Chip Menu: Lock By Time and Front Button Lock	52
Timer Menu: Setting The Timer	53
A/V Settings Menu: A/V Memory Reset, Video Mute, Black Enhancement, and A/V Settings	54
A/V Settings Menu: TV Speakers	55
A/V Setting Descriptions	56-57
Remote Control Functions	60-69
Overview	60
Care and Operation	61
Channel Selection and Sleep Timer	62
Operation of PIP and POP	62-63
Display Formats	64-65
Programming the Remote Control to Control NetCommand™ A/V Products	66
Programming the Remote Control to Control Non-NetCommand™ A/V Products	67-68
Special Functions	69
IMPORTANT NOTES	70
Appendix A: Bypassing the V-Chip Lock	71
Appendix B: Input Connection Compatibility	73
Appendix C: Remote Control Programming Codes	74
Appendix D: Cleaning and Service	75-76
Appendix E: Diamond Shield Instructions	77-78
Appendix F: Cabinet Separation	79-80
Appendix G: Troubleshooting	81-82
Index	83-84
Mitsubishi Projection TV Limited Warranty	85

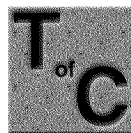

IMPORTANT SAFEGUARDS

Please read the following safeguards for your TV and retain for future reference.

Always follow all warnings and instructions marked on the television.

1. Read, Retain and Follow All Instructions

Read all safety and operating instructions before operating the TV. Retain the safety and operating instructions for future reference. Follow all operating and use instructions.

2. Heed Warnings

Adhere to all warnings on the appliance and in the operating instructions.

3. Cleaning

Unplug the TV from the wall outlet before cleaning. Do not use liquid, abrasive, or aerosol cleaners. Cleaners can permanently damage the cabinet and screen. Use a lightly dampened cloth for cleaning.

4. Attachments and Equipment

Never add any attachments and/or equipment without approval of the manufacturer as such additions may result in the risk of electrical shock or other personal injury.

5. Water and Moisture

Do not use the TV where contact with or immersion in water is possible. Do not use near bath tubs, wash bowls, kitchen sinks, laundry tubs, swimming pools, etc.

6. Accessories



Do not place the TV on an unstable cart, stand, tripod, or table. The TV may fall, causing serious injury to a child or adult and serious damage to the TV. Use only with a cart, stand, tripod, bracket, or table recommended by the manufacturer, or sold with the TV. Any mounting of the TV should follow the manufacturer's instructions, and should use mounting accessories recommended by the manufacturer.

An appliance and cart combination should be moved with care. Quick stops, excessive force, and uneven surfaces may cause the appliance and cart combination to overturn.

7. Ventilation

Slots and openings in the cabinet are provided for ventilation and to ensure reliable operation of the TV and to protect it from overheating. Do not block these openings or allow them to be obstructed by placing the TV on a bed, sofa, rug, or other similar surface. Nor should it be placed over a radiator or heat register. If the TV is to be placed in a rack or bookcase, ensure that there is adequate ventilation and that the manufacturer's instructions have been adhered to.

8. Power Source

This TV should be operated only from the type of power source indicated on the marking label. If you are not sure of the type of power supplied to your home, consult your appliance dealer or local power company.

9. Grounding or Polarization

This TV is equipped with a polarized alternating current line plug having one blade wider than the other. This plug will fit into the power outlet only one way. If you are unable to insert the plug fully into the outlet, try reversing the plug. If the plug should still fail to fit, contact your electrician or appliance dealer. Do not defeat the safety purpose of the polarized plug.

10. Power-Cord Protection

Power-supply cords should be routed so that they are not likely to be walked on or pinched by items placed upon or against them, paying particular attention to cords at plugs, convenience receptacles, and the point where they exit from the TV.

11. Lightning

For added protection for this TV during a lightning storm, or when it is left unattended and unused for long periods of time, unplug it from the wall outlet and disconnect the antenna or cable system. This will prevent damage to the TV due to lightning and power-line surges.

IMPORTANT SAFEGUARDS Continued

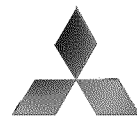

12. Power Lines

An outside antenna system should not be located in the vicinity of overhead power lines or other electric light or power circuits, or where it can fall into such power lines or circuits. When installing an outside antenna system, extreme care should be taken to keep from touching such power lines or circuits as contact with them might be fatal.

13. Overloading

Do not overload wall outlets and extension cords as this can result in a risk of fire and electric shock.

14. Object and Liquid Entry

Never push objects of any kind into this TV through openings as they may touch dangerous voltage points or short-out parts that could result in fire and electric shock. Never spill liquid of any kind on or into the TV.

15. Outdoor Antenna Grounding

If an outside antenna or cable system is connected to the TV, be sure the antenna or cable system is grounded so as to provide some protection against voltage surges and built-up static charges.

Section 810 of the National Electric Code, ANSI/NFPA No. 70-1984, provides information with respect to proper grounding of the mast and supporting structure, grounding of the lead in wire to an antenna discharge unit, size of grounding conductors, location of antenna discharge unit, connection to grounding electrodes, and requirements for the grounding electrode.

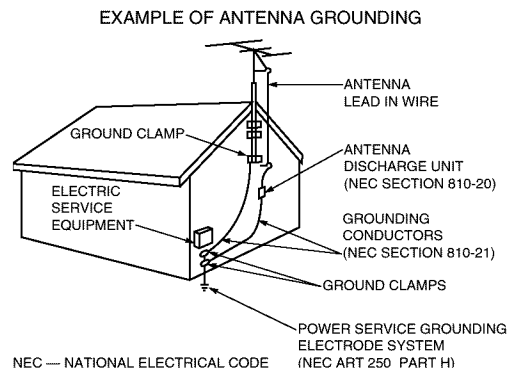

16. Servicing

Do not attempt to service this TV yourself as opening or removing covers may expose you to dangerous voltage or other hazards. Refer all servicing to qualified service personnel.

17. Damage Requiring Service

Unplug the TV from the wall outlet and refer servicing to qualified service personnel under the following conditions:

- When the power-supply cord or plug is damaged.
- If liquid has been spilled, or objects have fallen into the TV.
- If the TV has been exposed to rain or water.
- If the TV does not operate normally by following the operating instructions, adjust only those controls that are covered by the operating instructions as an improper adjustment of other controls may result in damage and will often require extensive work by a qualified technician or reset the TV to its normal operation.
- If the TV has been dropped or the cabinet has been damaged.
- When the TV exhibits a distinct change in performance - this indicates a need for service.

18. Replacement Parts

When replacement parts are required, be sure the service technician has used replacement parts specified by the manufacturer or have the same characteristics as the original part. Unauthorized substitutions may result in fire and electric shock or other hazards.

19. Safety Check

Upon completion of any service or repair to the TV, ask the service technician to perform safety checks to determine that the TV is in safe operating condition.

20. Heat

The product should be situated away from heat sources such as radiators, heat registers, stoves, or other products (including amplifiers) that produce heat.

If you have questions regarding your television, call
Consumer Relations
at (800) 332-2119, or email us at
MDEAservice@bigscreen.mea.com

To order replacement or additional remote controls or owner's
guides
call (800) 553-7278

or

visit our website at www.mitsubishi-tv.com

Part I

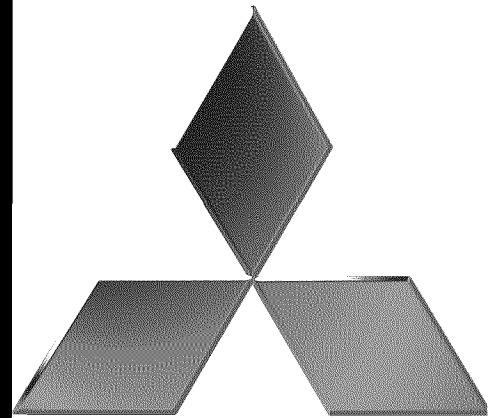

Thank You

Thank You Letter	8
Unpacking Your New TV	9
Special Features	9

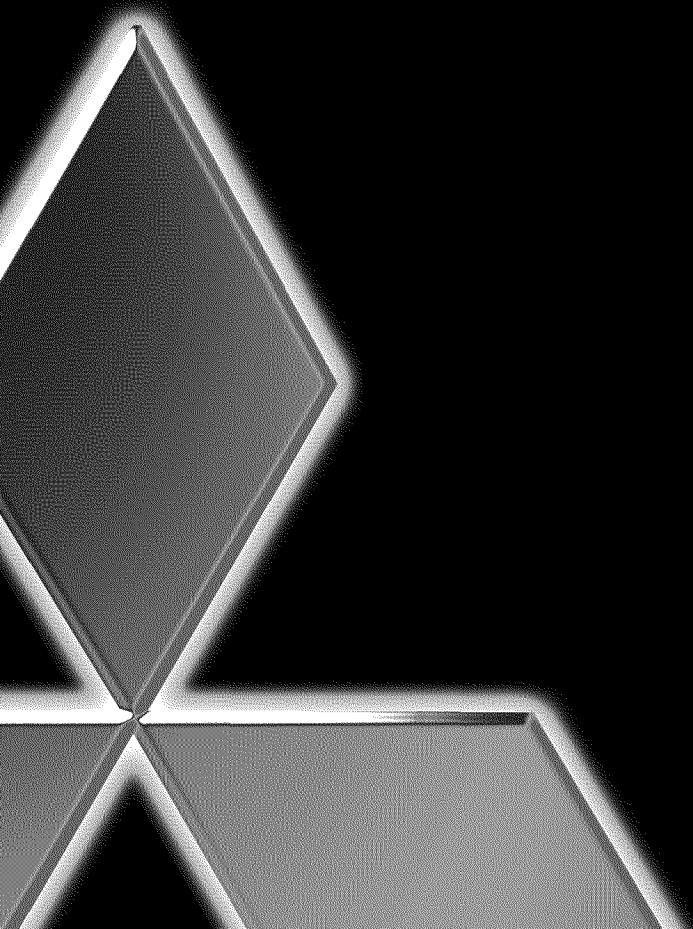



We at Mitsubishi Would Like to Thank You

To the Mitsubishi Consumer:

Thank you for choosing Mitsubishi as your premier home entertainment partner. The development team at Mitsubishi understands that our customers demand and expect the very best. Mitsubishi is founded on the core beliefs and philosophies that drive us to deliver products that lead the industry. Your new television includes True HDTV™ performance and new digital home-networking technology, both of which break new ground in performance, ease of use, and future upgradeability.

Whether this is your first Mitsubishi consumer electronics product or an addition to your growing Mitsubishi family, we hope that this television will bring you and your family many hours of enjoyment.

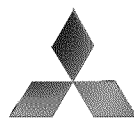

Unpacking Your New TV

Please take a moment to review the following list of items to ensure that you have received everything included:

- 1** Remote Control
- 2** (2) AAA Batteries
- 3** (1) Digital Audio Cable
- 4** (1) Double IR Emitter Cable
- 5** (1) Quadruple IR Emitter Cable
- 6** Product Registration Card
- 7** Owner's Guide
- 8** Quick Reference Card
- 9** NetCommand™ Guide
- 10** Connection Configuration Diagrams

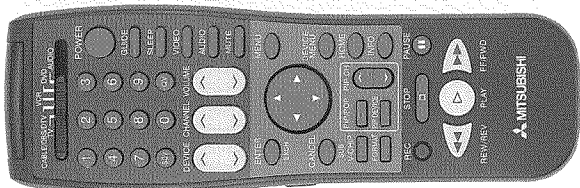

- 1** Remote Control

- 2** (2) AAA Batteries

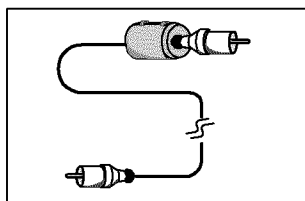
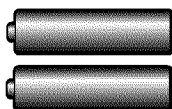

- 3** (1) Digital Audio Cable

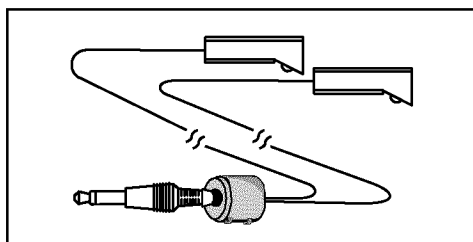

- 4** (1) Double IR Emitter Cable

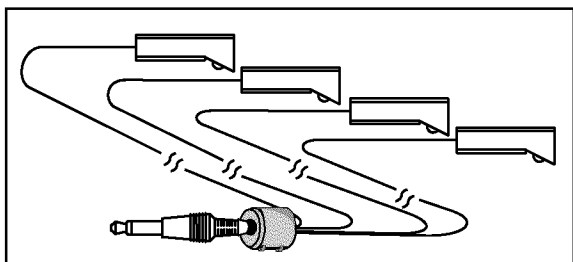

- 5** (1) Quadruple IR Emitter Cable

Special Features

Your new High Definition broadcast television has many special features that make it the perfect addition to your home entertainment system. Below we have highlighted a handful.

Fully Integrated HDTV

Your Mitsubishi bigscreen TV can receive all approved terrestrial broadcast digital signals, non-scrambled digital cable signals, terrestrial analog signals and non-scrambled analog cable signals that use a standard offset carrier system. Further, your TV will display all High Definition signals as 1080i True HDTV™ and all standard definition signal will be displayed as 480p.

NetCommand™ Home Network Control System

NetCommand™ features and technology patent pending.

Your Mitsubishi bigscreen HDTV offers a new level of networking to combine selected older products with new and future digital products. NetCommand™ supports IEEE 1394 connections, HAVi (Home Audio Video Interoperability) Control system, Audio Video Control system (AV/C), 5C copy protection and IR control of selected older products such as VCRs, DVD players, cable boxes or satellite receivers. All operating in a similar manner using on-screen graphical menus and a single remote control. See the NetCommand™ Guide for instructions on how to use this feature.

Wide Screen Picture Format

You will be able to view pictures as the directors intended you to see them. Both DTV and DVD's supporting the widescreen format will enable you to enjoy a theater feel in the comfort of your home.

PIP/POP Viewing Option

Using Picture-in-Picture and Picture-outside-Picture will give you exciting options for viewing your favorite programs.

V-Chip Technology

Your Mitsubishi bigscreen will allow you to restrict viewing of programming by general content, category contents, or even by time.

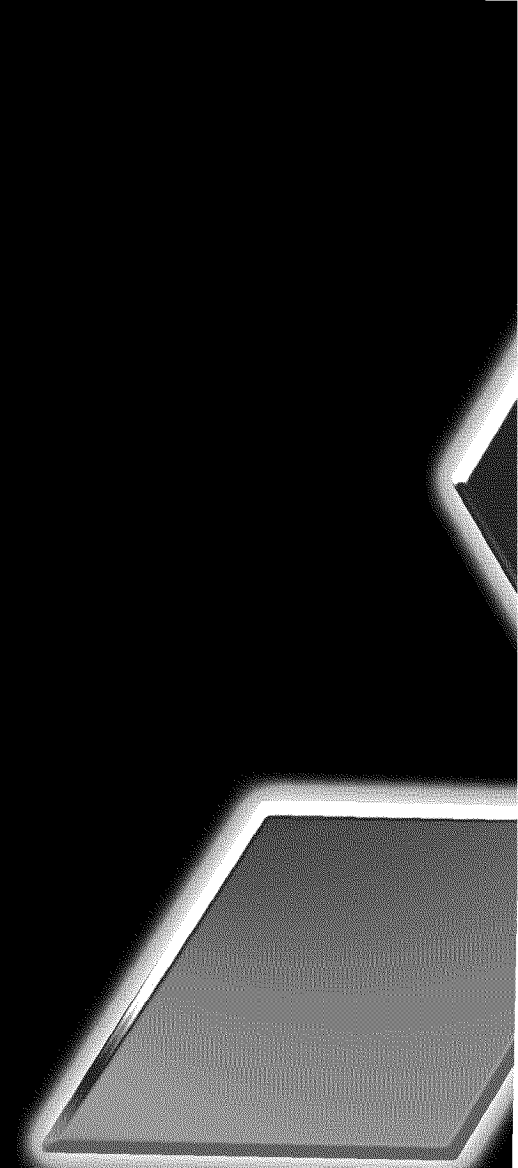

Part II

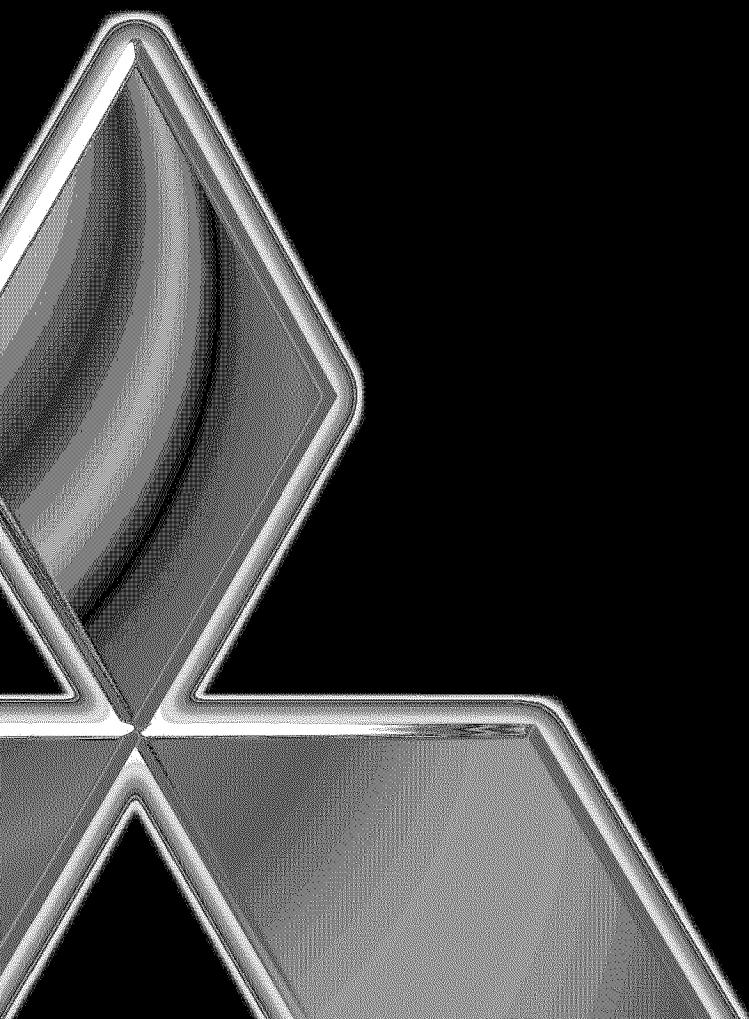

Installation

Front Control Panel Functions	12
Back Panel Functions	13-14
Installation Con g u r a t i o n s and NetCommand™ Setup	15
NetCommand™ Supported Devices	16
Connecting to Your New Mitsubishi Bigscreen:	
Antenna or Wall Outlet Cable for Digital Broadcasts	17
Analog Antenna, Wall Outlet Cable or Cable Box	18
Analog VCR	19
A/V Receiver	20
DVD Player or S-Video VCR or Satellite Receiver	21
External DTV Receiver	22-23
Computer and the IR Home Theater Control and IR Repeater	24

Front Control Panel

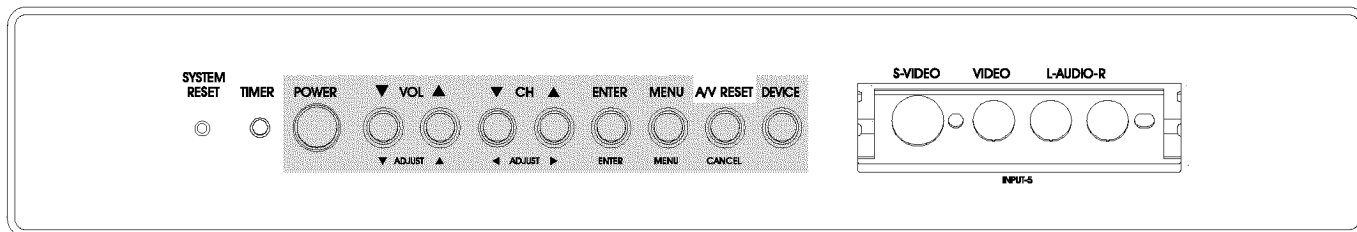

Figure 1. Front Control Panel.

The buttons on the front control panel that are highlighted in gray are duplicated on the remote control. The top row of labels show the control functions when there are no TV menus displayed on the screen. The bottom row of labels show the control functions when the TV menus are displayed on the screen. See **Remote Control Functions: Overview**, page 60, for details on their functions.

System Reset

If the TV will not respond to either the remote control or the front panel controls and will not power off, press the SYSTEM RESET button with a pointed item like the point of a ball point pen. The TV will turn off and the TIMER light will flash about one minute. When the TIMER light stops flashing, you may turn the TV again. The changes you made while the TV was on before you used the SYSTEM RESET button may be cancelled, however, the changes you made previously are not cancelled. Only the changes since the last power on may be lost when the system reset button is pressed. All other settings are retained.

Timer

The green light is a multi-function indicator. Each time the TV is plugged into the wall electrical outlet, or when power is restored after a power failure, or after using the SYSTEM RESET button, this light will flash about one minute. Do not attempt to turn on the TV during this period, wait for the light to stop flashing before attempting to turn the TV on. When the TV is turned on, the light will be illuminated steadily. If the TV has been programmed to turn on automatically using the Timer feature, this light will flash slowly while the TV is powered off.

A/V Reset

Press this button to reset all A/V memories to the factory default settings.

Input 5

This input can be used for convenient connection of a camcorder or other video device to the TV. Please note that if you connect to the S-VIDEO terminal, the VIDEO terminal is deactivated. The VIDEO terminal is active when there is no S-Video connection.

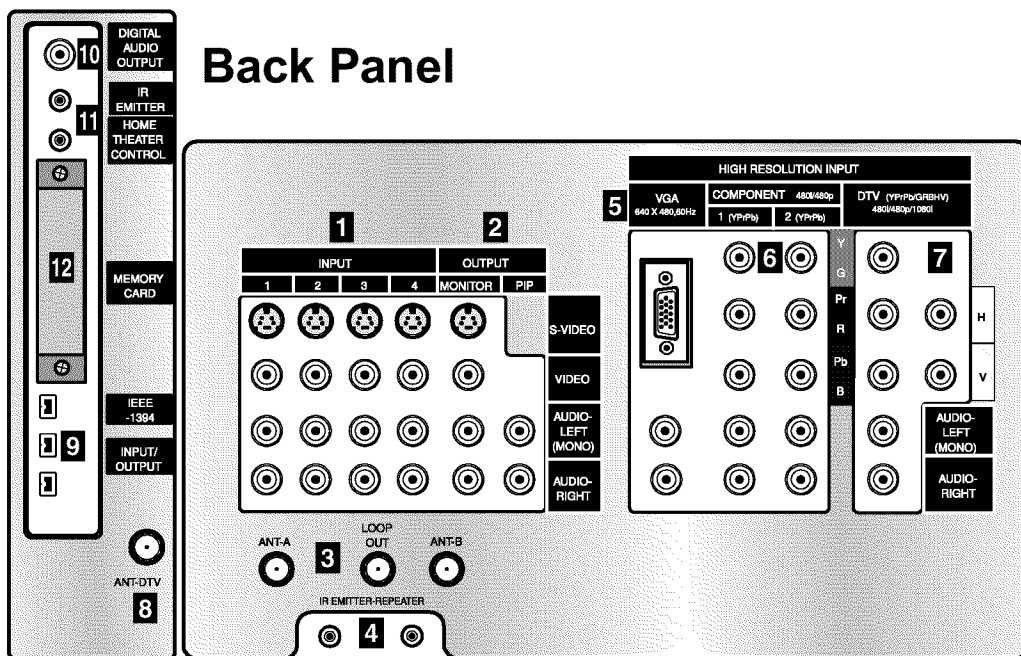

1 Inputs 1-4

These inputs can be used for the connection of a VCR, Super VHS (S-VHS) VCR, DVD player, standard satellite receiver, or other A/V device to the TV. Please note that if you connect to the S-VIDEO terminal, the VIDEO terminal is deactivated. The VIDEO terminal is active when there is no S-Video connection.

2 Output (Monitor and PIP)

The Monitor Output sends the TV audio and video signals from Ant-A, Ant-B and Inputs 1-5 to a VCR or other analog A/V equipment. It will also send digital audio and video signals from Ant-DTV and IEEE-1394 products that are not copy protected, and convert them to analog signals. From VGA, Component 1 and 2 and Input-DTV, no signals will be sent. The PIP output sends the PIP's or POP's audio signal to an amplifier or wired headphones. If no PIP or POP is displayed, the PIP output will not send any audio.

3 Antenna (ANT-A, LOOP OUT, and ANT-B)

ANT-A and ANT-B receive analog NTSC signals from VHF/UHF antennas or an analog NTSC cable system. LOOP OUT sends the ANT-A signal out to another component, such as a cable box or VCR.

4 IR Emitter-Repeater

Connecting IR emitters here allows the TV to pass IR commands from most IR remote controls to other A/V devices that are out of range of the remote control.

5 VGA

This input can be used for the connection of a computer. Please see *Appendix B*, page 73, for signal compatibility.

6 Component Inputs 1-2

These inputs can be used for the connection of A/V equipment with component video outputs, such as a DVD player. Please see *Appendix B*, page 73, for signal compatibility.

7 DTV Input

This input is used to connect a DTV receiver, and can be configured for HDTV signal types component (YPrPb), RGB sync on green, and RGB plus H&V. Please see *Appendix B*, page 73, for signal compatibility.

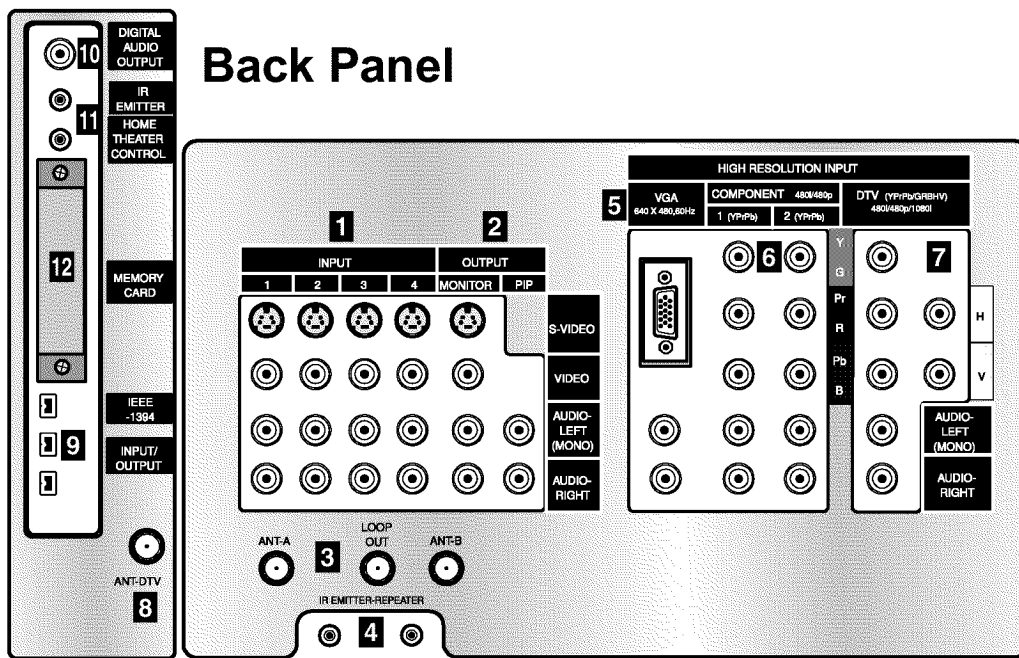

8 Antenna DTV (ANT-DTV)

This input receives digital TV signals from a VHF/UHF antenna or unscrambled digital cable system. If the TV receives scrambled signals on this input, it will not be able to decode them. In this case, your cable company must provide a decoding box.

9 IEEE-1394 Input/Output

These jacks allow the TV to connect to one or more external A/V products by means of a single cable. Three jacks are provided for this purpose, which allow for a high degree of flexibility for connecting your system together. Please refer to the NetCommand™ Guide for IEEE-1394 device connection details.

10 Digital Audio Output

This output provides digital audio streams, such as Dolby Digital or other types of digital audio, received in the signal from the ANT-DTV input or the IEEE-1394 devices. This output is intended to be connected to an external audio receiver that is capable of decoding the digital streams and converting them to analog signals suitable for driving loudspeakers.

11 IR Emitter-Home Theater Control Output

Two jacks are provided for connecting IR emitters. These emitters are used to control external analog devices such as VCRs, DVDs, cable boxes, satellite receivers and audio receivers by means of the NetCommand™ features of the TV.

12 Memory Card

The card slot behind the cover allows the software of the TV to be updated with expanded features by use of a flash card provided by Mitsubishi. The TV does not come with the card and does not require a card when it is first received. You should not attempt to use a flash card that is not authorized by Mitsubishi or insert any other item into it or this may cause damage to your TV that is not covered by your warranty. When software updates are available, they will be announced on our web site, www.mitsubishi-tv.com. If you return your Owner's Registration card with your model and serial number, you may receive written notification.



Installation Configurations & NetCommand™ Setup

With this book you will read about pages that show overviews of standard pre-established system connections, called configurations. These diagrams specify the inputs to use on the TV and on the NetCommand™ supported Audio Video (A/V) Receivers. Later pages in this book will show details on how to connect devices to individual TV inputs.

Use the configuration that most closely matches the devices you wish to connect to the TV. Connect those devices as closely as possible to the diagram. It is OK if you cannot match the diagram perfectly. The NetCommand™ setup system will allow you to alter the configuration to make changes you need to make. If you do not have one of the devices specified in the configuration, the NetCommand™ setup system will give you the option to select “None” for that device. As an example, if you do not have an A/V receiver, connect the left and right stereo audio cables from each device directly to the TV. In the NetCommand™ Setup system you will be given the opportunity to specify “None” for A/V receiver and the TV will know to use the TV speakers for all sound. You can use brands and/or models of devices that are not supported by NetCommand™ by selecting “Other”. On the real screen for the setup there is an “Edit” option. The edit option will allow you to change the settings; for instance you can select a different TV input or A/V receiver input to use with a device, add a device that is not in the original configuration, or give a different name to the device. The setup can also be edited at a later date, from Setup in the TV menu, to adjust to changes in your system.

For instructions concerning the connection and addition of IEEE 1394 devices to your system, see the separate NetCommand™ Guide. The devices for each configuration are shown in the table below.

NetCommand™ Setup Configurations

Configurations	External Devices								
	Cable and/or Antenna	Cable Box with channel 3, 4, or 5 output	Cable Box with Audio Video output	DBS Satellite Receiver	VCR	VCR 2	DVD player	Audio/Video Receiver	Camcorder (temporary connection)
#1	●	●			●		●	●	
#2	●				●		●	●	
#3	●		●		●		●	●	
#4	●			●	●		●	●	●
#5	●			●	●	●	●	●	●
#6	●			●*	●	●	●	●	●

Table 1.

*High Definition DBS Receiver.

NetCommand™ Supported Devices

Following is a list of devices by several manufacturers that have been tested and shown to be compatible with the NetCommand™ control system. When you use these devices you will be able to control them without changing the setting of the remote control from TV to another product.

NetCommand™ Compatible Legacy Devices

Brand	Device/Model				
	AV Receiver	Cable Box	DBS-Sat Receiver	DVD Player	VCR
Mitsubishi	M-VR800		SR-HD5	DD-6000	HS-U795**
Denon	AVR-2700				
DishNetwork(Echostar)			6000		
General Instruments		CFT-2200			
Hughes			HIRD-E45		
Jerrold		See GI*			
JVC					HR-650U
Kenwood	VR-2080				
Motorola		See GI*			
Panasonic				DVD-A310U/CA	PV-8662
Pioneer	VSX-D557			DV-414	
RCA			DRD480RE		
Scientific Atlanta		8600			
Sony	STR-DE825		SAT-A55	DVP-S500D	SLV-778HF
Toshiba				SD-9200	
Yamaha	RX-V2095				

* No special models

** Supports both VCR-A and VCR-B remote control system

Since similar devices from the same manufacturer often operate the same way, other models may be compatible, however they have not been tested so not all NetCommand™ functions may be available. For devices that are not supported by NetCommand™, you will need to use that device's original remote control or program the TV remote to operate these devices in the traditional manner.

Connecting Antenna or Wall Outlet Cable for Digital Broadcasts

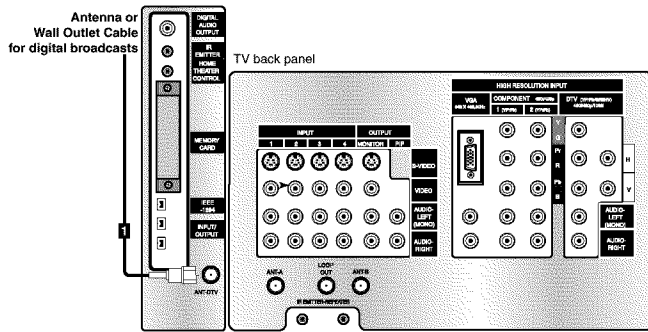

Figure 1. Antenna or wall outlet cable.

Antenna or Wall Outlet Cable for Digital Broadcasts.

For cable or antenna with coaxial lead (Figure 1)

- 1 Connect the incoming cable to ANT-DTV on the TV back panel.

Mitsubishi strongly recommends against using antennas with twin leads. Twin lead antenna wires are subject to interference which may adversely affect the performance of the TV. We recommend using coaxial antenna cable.

IMPORTANT

→ Additional connection cables are not provided with the TV. They should be available at most electronic stores.

Connecting an Analog Antenna, Wall Outlet Cable, or Cable Box

Separate UHF and VHF Antennas (Figure 1)

- 1 Connect the UHF and VHF antenna leads to the UHF/VHF combiner.
- 2 Push the combiner onto ANT-A on the TV back panel.
- ➡ UHF/VHF combiners are not provided with the TV. They should be available at most electronic stores.

Mitsubishi strongly recommends against using antennas with twin leads. Twin lead antenna wires are subject to interference which may adversely affect the performance of the TV. We recommend using coaxial antenna cable.

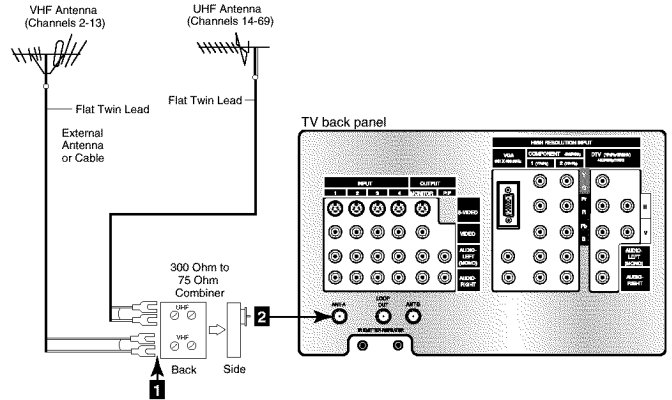

Figure 1. Connecting separate UHF and VHF antennas.

Antenna or Wall Outlet Cable for Analog Broadcasts. (Figure 2)

For antennas with twin lead

- 1 For antenna with twin leads, connect the 300-Ohm twin leads to the transformer.
- 2 Push the 75-Ohm side of the transformer onto ANT-A on the TV back panel.
- ➡ 300-Ohm to 75-Ohm matching transformers are not provided with the TV. They should be available at most electronic stores.

For cable or antenna with coaxial lead

- 3 Connect the incoming cable to ANT-A on the TV back panel.

Mitsubishi strongly recommends against using antennas with twin leads. Twin lead antenna wires are subject to interference which may adversely affect the performance of the TV. We recommend using coaxial antenna cable.

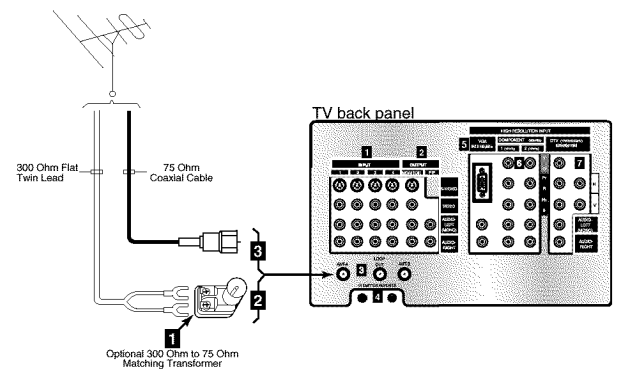

Figure 2. Connecting antenna or wall outlet cable for analog broadcasts.

Cable Box (Figure 3)

(Figure 3)

- 1 Connect the incoming cable to ANT-A on the TV back panel.
- ➡ Connect two coaxial cables as follows: One from LOOP-OUT on the TV back panel to
- 2 IN on the cable box back panel.
- 3 One from OUT on the cable box back panel to ANT-B on the TV back panel.

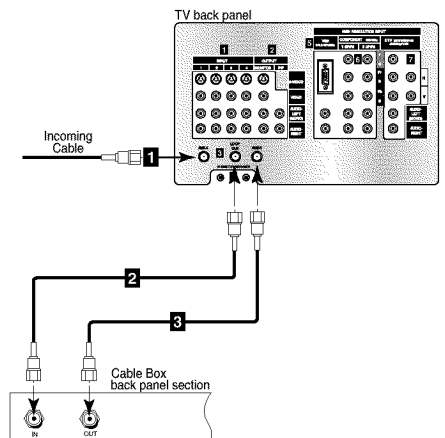

Figure 3. Connecting the cable box.

Connecting an Analog Antenna, Cable, or Cable Box

Connecting an Analog VCR

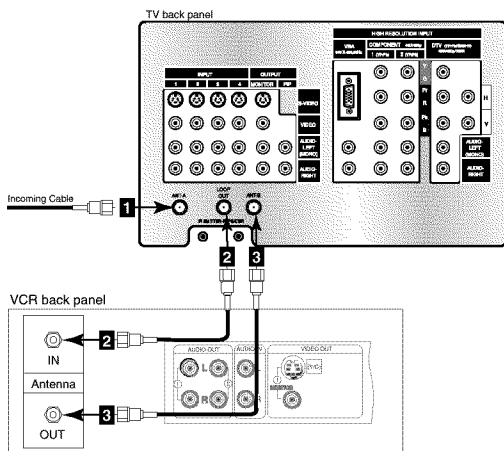

Figure 1. Connecting VCR with antennas or wall outlet cable.

IMPORTANT

→ Additional connection cables are not provided with the TV. They should be available at most electronic stores.

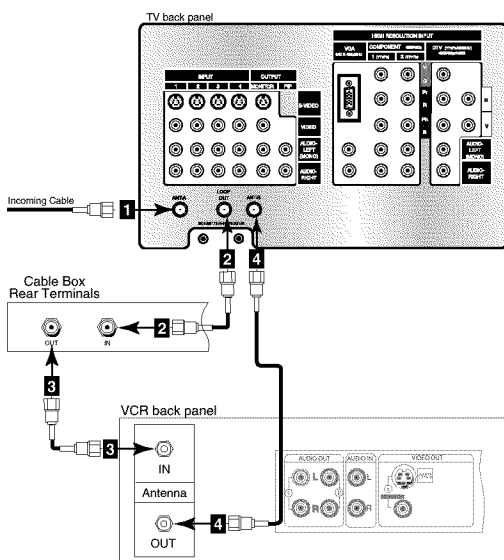

Figure 2. Connecting VCR with cable box.

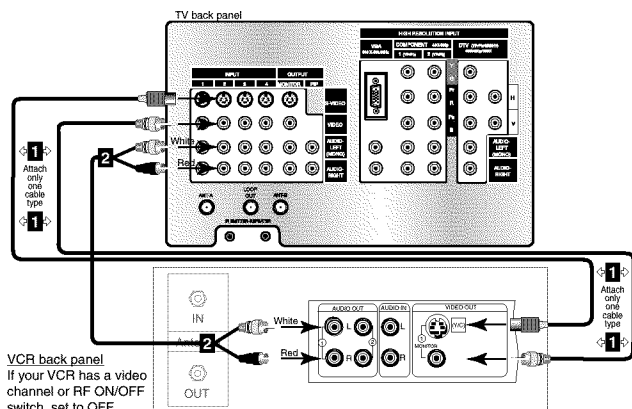

Figure 3. Connecting the VCR Audio/Video.

Analog Antennas or Wall Outlet Cable

(Figure 1)

- 1 Connect the incoming cable to ANT-A on the TV back panel.
- Connect two coaxial cables as follows:
- 2 One from LOOP-OUT on the TV back panel to ANTENNA IN on the VCR back panel.
- 3 One from VCR back panel ANTENNA OUT to ANT-B on the TV back panel.
- 4 Now complete [guide 3, steps 1-2](#)

Cable Box

(Figure 2)

- 1 Connect the incoming cable to ANT-A on the TV back panel.
- Connect three coaxial cables as follows:
- 2 One from LOOP-OUT on the TV back panel to IN on the back of the cable box.
- 3 One from OUT on the back of the cable box to ANTENNA IN on the VCR back panel.
- 4 One from ANTENNA OUT on the VCR back panel to ANT-B on the TV back panel.
- 5 Now complete [guide 3, steps 1-2](#)

Adding Composite Video or S-Video with Audio Connections

(Figure 3)

- 1 Connect a video cable from VIDEO OUT on the VCR back panel to VIDEO INPUTS 1, 2, 3, or 4 on the TV back panel.
- If you have a S-VHS VCR, follow the same steps using the S-Video terminals on the VCR and TV (in place of the composite terminals).
- 2 Connect a set of audio cables from AUDIO OUT on the VCR back panel to AUDIO INPUT 1, 2, 3, or 4 on the TV back panel. The red cable connects to the R (right) channel and the white cable connects to the L (left) channel. If your VCR is mono (non-stereo), connect only the white (left) cable.



Connecting an Audio/Video Surround Sound Receiver

Connecting an A/V Receiver

(Figure 1)

- 1** Connect a video cable from Monitor VIDEO OUTPUT on the back of the TV to the TV VIDEO INPUT on the back of the A/V Receiver.
- 2** If you have connected a S-VHS VCR to the A/V Receiver, then follow the same video connection using the S-Video cable and terminals on the TV and A/V Receiver (in place of the VIDEO cable).
- 2** Connect a set of audio cables from the Monitor AUDIO OUTPUT on the back of the TV to the TV AUDIO INPUT on the back of the A/V Receiver. The red cable connects to the R (right) channel and the white cable connects to the L (left) channel.

If connecting a digital A/V Receiver with Dolby Digital™ surround sound.

- 3** Connect one end of the digital audio cable supplied with the TV to the DIGITAL AUDIO OUTPUT on the back of the TV (connect the end of the cable with the ferrite or plastic cylinder). Connect the other end to the COAXIAL DIGITAL INPUT on the back of the A/V Receiver. Check the Owner's Guide for the A/V Receiver for information concerning the use of the digital input and switching between the digital sound and analog stereo sound from the TV.

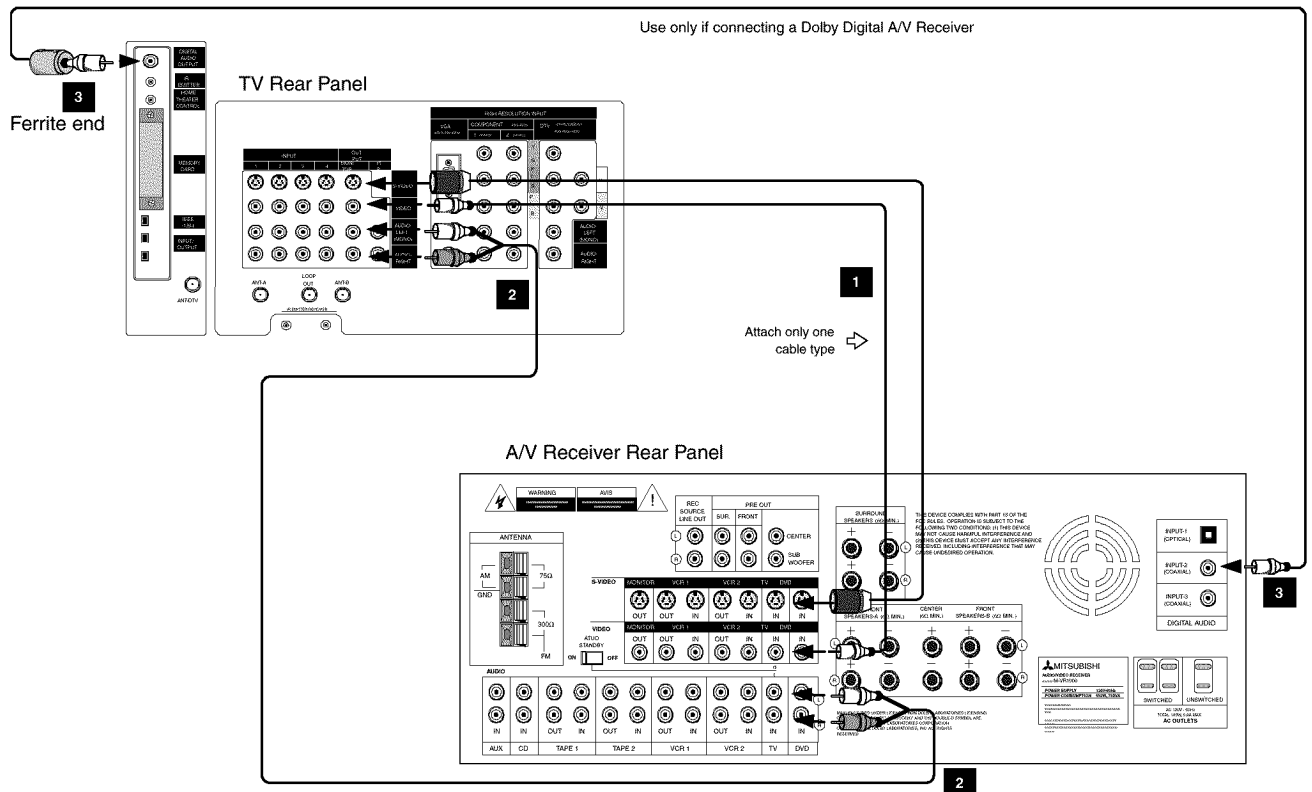

Figure 1. Connecting an Audio/Video Receiver



WARNING: Do not display the same stationary images on the screen for more than 15% of your total TV viewing in one week. Examples of stationary images are letterbox top/bottom bars from DVD or other video sources, side bars when showing standard TV pictures on widescreen TV's, stock market reports, video game patterns, station logos, web sites, or stationary computer images. Such patterns can unevenly age the picture tubes causing permanent damage to the TV. Please see page 70 for a detailed explanation.

Connecting a DVD Player

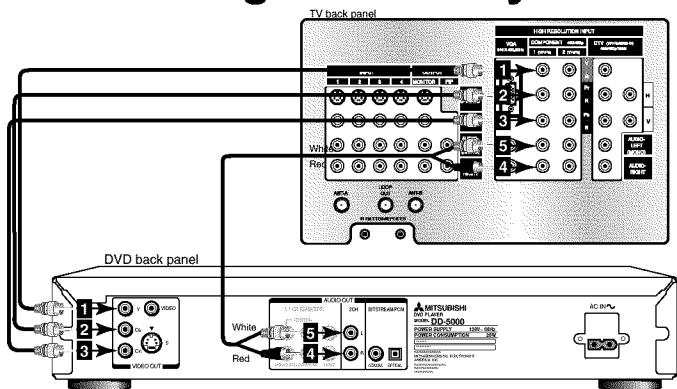

Figure 1. Connecting the DVD player.

IMPORTANT

- See Appendix B, page 73, for component video signal compatibility information.
- For digital audio connections, see your DVD and A/V receiver Owner's Guides.

DVD Player with Component Video

(Figure 1)

- Connect the Component Video cables from Y/Cr/Cb or Y/Pr/Pb VIDEO OUT on the back of the DVD player to COMPONENT-1 or COMPONENT-2 on the TV back panel, matching the correct connection:

- 1 Y to Y
- 2 Cr or Pr to Pr
- 3 Cb or Pb to Pb

- Connect a set of audio cables from AUDIO OUT on the back of the DVD player to COMPONENT AUDIO Input 1 or 2 on the TV back panel. The red cable 4 connects to the R (right) channel, and the white cable 5 connects to the L (left) channel.

Connecting an S-Video VCR or Satellite Receiver

S-Video VCR or Satellite Receiver

(Figure 2)

- 1 Connect an S-Video cable from VIDEO OUT on the device back panel to VIDEO INPUT-1, INPUT-2, INPUT-3, or INPUT-4 on the TV back panel.

- 2 Connect a set of audio cables from AUDIO OUT on the device back panel to AUDIO INPUT-1, INPUT-2, INPUT-3, or INPUT-4 on the TV back panel. The red cable connects to the R (right) channel and the white cable connects to the L (left) channel. If your device is mono (non-stereo), connect only the white (left) cable.

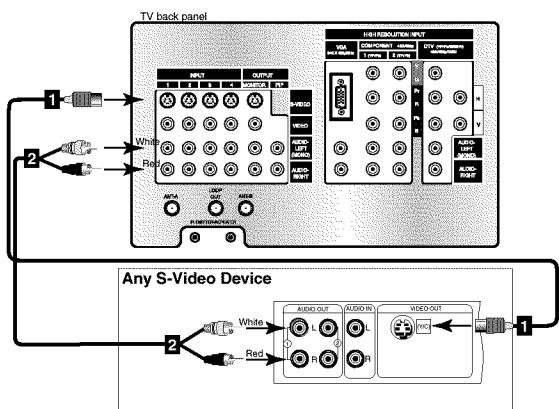

Figure 2. Connecting an S-Video Device.

Connecting an External DTV Receiver

DTV Connectors and Adaptors

(Figure 1)

The TV back panel has 5 RCA-type connectors, for the Input-DTV. The back panel of your external DTV receiver may use RCA-type connectors or BNC-type connectors. If your DTV receiver comes with BNC type connections, you will need to purchase BNC to RCA adaptors to connect the TV to the DTV receiver. These adaptors should be available at most electronic supply stores.

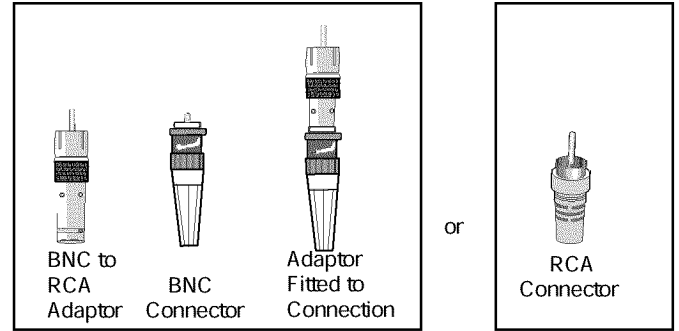

Figure 1. DTV connectors and adaptors.

External DTV Receiver with Component Video Connections

(Figure 2)

- 1 Connect the outside antenna, cable, or satellite to ANT, or SATELLITE IN on the DTV receiver (see your DTV receiver's owner's guide for instructions, and cable compatibility).
- 2 Connect the incoming terrestrial antenna, or cable (not satellite) to ANT-A on the TV back panel (a coaxial splitter, available at most electronic supply stores, may be required to complete this installation).
- 3 Connect the RCA-type cables from the YPrPb outputs on the DTV receiver to Input-DTV on the TV back panel. You may need to set the Input-DTV assignment to YPrPb using the "Change" option of the Edit Setup menu. Select this device to change and this assignment will be available.
- 4 Connect the L (left) and R (right) audio cables from the DTV receiver to Input-DTV AUDIO on the TV back panel.
- ➔ To utilize the benefits of a digital A/V receiver, connect your DTV receiver's digital audio out to a digital input on your digital A/V receiver.

IMPORTANT

- ➔ See Appendix B, page 73, for component video signal compatibility information.
- ➔ For digital audio connections, see your DTV receiver and A/V receiver Owner's Guides.

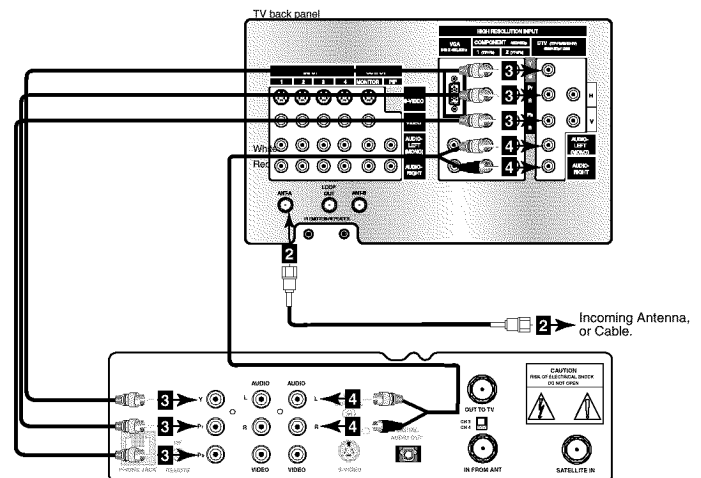

Figure 2. Connecting the DTV receiver with component video connections.

Connecting an External DTV Receiver



External DTV Receiver with RGB Video Connections

(Figure 1)

IMPORTANT

- See Appendix B, page 73, for RGB video signal compatibility information.
- For digital audio connections, see your DTV receiver and A/V receiver Owner's Guides.

- 1** Connect the outside antenna, cable, or satellite to ANT, or SATELLITE IN on the DTV receiver (see your DTV receiver's owner's guide for instructions, and cable compatibility).
- 2** Connect the incoming terrestrial antenna, or cable (not satellite) to ANT-A on the TV back panel (a coaxial splitter, available at most electronic supply stores, may be required to complete this installation).
- Connect the RGB cables for the DTV receiver to the Input-DTV on the TV back panel. You may need to set the Input-DTV assignment to RGB using the "Change" option of the Edit Setup menu. Select this device to change and this assignment will be available.

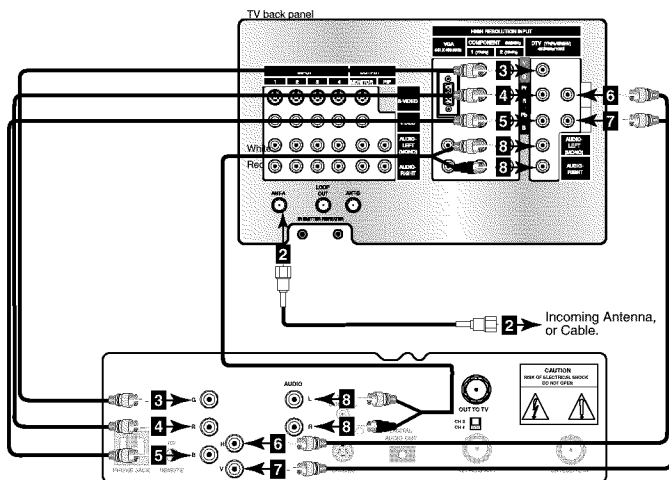

Figure 1. Connecting the DTV receiver with RGB video connections.

DTV Receiver	=	TV Back Panel
3 G (green)	=	Y/G
4 R (red)	=	Pr/R
5 B (blue)	=	Pb/B

- If the DTV receiver has outputs for H and V sync, connect as listed below (**DO NOT** connect if DTV receiver uses "Sync on Green"):

6 H (horizontal sync) =	H
7 V (vertical sync) =	V

- 8** Connect the L (left) and R (right) audio cables from the DTV receiver to Input-DTV AUDIO on the TV back panel.
- To utilize the benefits of a digital A/V receiver, connect your DTV receiver's digital audio out to a digital input on your digital A/V receiver.

Connecting a Computer with a VGA Monitor Output

Connecting a Computer

(Figure 1)

- 1 Connect VGA Monitor Out from the computer to VGA on the TV back panel using a VGA compatible monitor cable. See *Appendix B*, page 73, for VGA signal compatibility.
- 2 Connect the L (left) and R (right) audio cables from the computer to VGA AUDIO on the TV back panel. In cases where your computer's audio output is a single mini-jack, a splitter is needed to complete this connection.
- ➔ To utilize the benefits of a digital A/V receiver, connect your computer's digital audio out, if available, to a digital input on your digital A/V receiver.

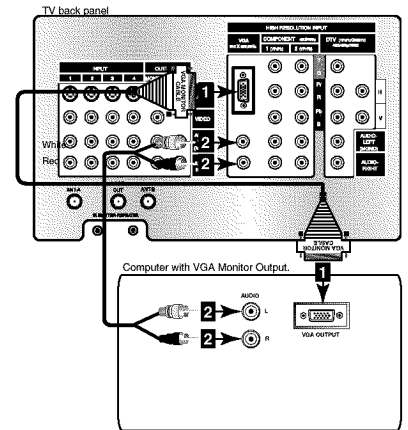

Figure 1. Connecting a computer with a VGA monitor output.

CAUTION: To assure continued FCC compliance, the user must use a shielded video interface cable with bounded ferrite cores, when using the VGA input.

Connecting the IR-Home Theater Control and IR Repeater

(Figure 2)

IR Emitter-Home Theater Control

These emitters are not IR repeaters, but instead used by the NetCommand feature to control supported devices.

- 1 a: Connect the IR emitter to IR EMITTER-HOME THEATER CONTROL on the TV back panel.

OR

IR Emitter-Repeater

These emitters are not used by NetCommand, but will repeat any IR command received by the TV. These emitters allow the TV to be the remote control sensor for other devices that are outside of the range of the handheld remote control. Do not use these repeaters with devices that can receive the remote control signal directly, as the signals can interfere with each other.

- 1 b: Connect the IR emitter to IR EMITTER-REPEATER on the TV back panel.

THEN

- 2 Place the IR emitter cable under or along the side of the A/V device. Place the IR lens directly in front of the A/V device's infrared signal receiver. Infrared signal receivers are usually behind the front translucent panel of the device.
- 3 Place unused transmitters in an out-of-the-way location.
- 4 For permanent installation of the IR emitter cable, use the included adhesive tape to secure the bottom of the emitter to the anchoring object of your choice.

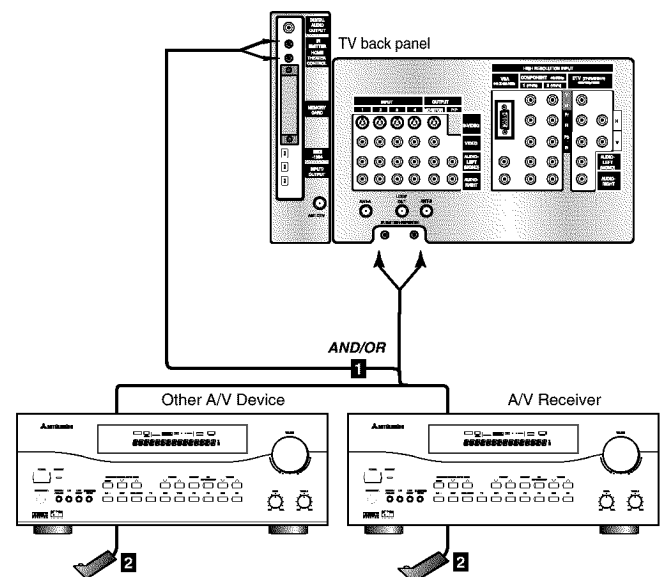
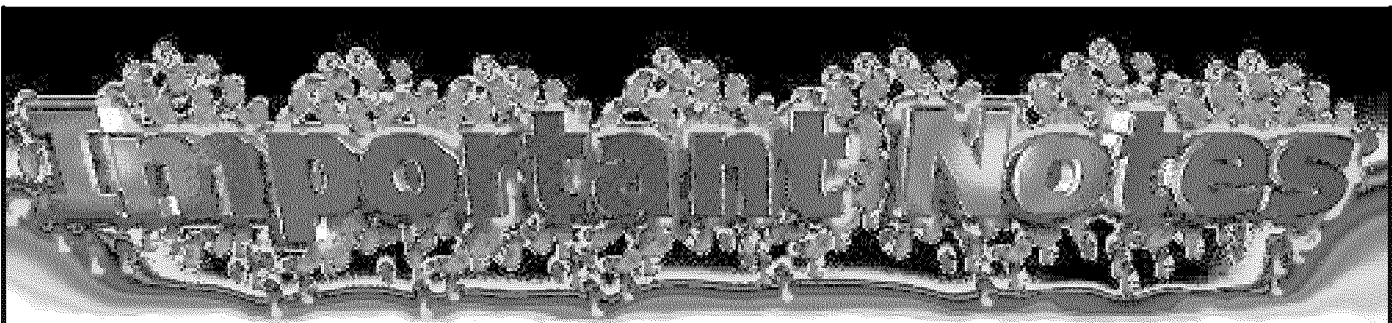

Figure 2. Connecting the IR Home Theater Control and/or Repeater.



Warning: Do not leave stationary, toolbar, or partial images on-screen for extended periods of time. Mix the types of pictures shown. Uneven picture tube aging is NOT covered by your warranty.

The VGA capability of this television is designed for occasional use ONLY.

It is not meant to be used as a work station or to view static or odd-shaped images for an extended period of time. Any device connected to your television via the VGA port, including, but not limited to, personal computer, game system, or digital set-top box, must have its screen saver function activated to prevent damage to the television. We **DO NOT** recommend the use of any external device that does not have a screen saver function with this television.

We recommend that screen saver activation time be set to less than 10 minutes when using a device through the VGA port. You should also use lower brightness and contrast settings. If your computer programs allow, toolbars should be set to hidden mode.

Please remember that most computer programs and video game systems display static images, such as boxes, buttons, toolbars, and game scores that can damage the television if used for extended periods of time, repeatedly, or frequently.

The VGA input will automatically select the "Standard" screen format and fill the screen. No other formats are available with the VGA Input. Standard television overscan is used, so VGA images will be cropped on all sides. Resizing of some displays may be required. Consult your owner's manual for computers, computer programs and game systems for assistance with resizing display images. Please see page 70 for an explanation of uneven picture tube aging.

The NetCommand™ Initial Setup

In order to use your TV's NetCommand feature, you are going to have to provide some detailed information for the initial setup of your Mitsubishi TV. You must determine the manufacturer and model of the devices that you connect to the television. The inputs to the TV and A/V receiver and the names for the device are pre-determined during Initial Setup, but can be changed using the Edit Setup Screen.

On your remote control, pressing ADJUST ◀ and ▶ button allows you to navigate through the NetCommand™ Setup. The ADJUST ▲ and ▼ buttons and the ENTER buttons allows you to change settings and make selections.

Pressing Adjust ▲ and ▼ changes the selection. Press ENTER to check or uncheck check boxes, to select push buttons which change screens such as Next>, <Back, or Cancel.

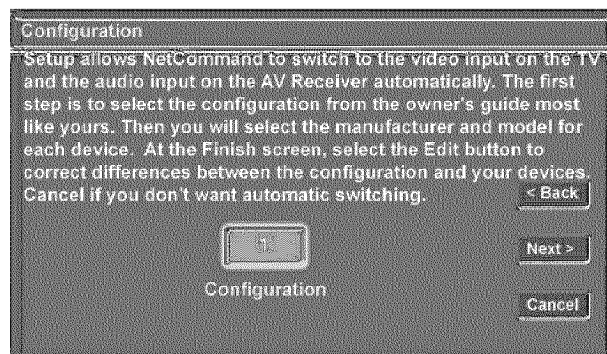

Figure 1. Configuration menu.

Buttons

Much like the software on your computer, you will use graphic buttons to navigate through the NetCommand™ Setup

<Back Button

Use the <Back button to navigate back to the previous screen.

Next> Button

Use the Next> button to navigate forward to the next screen.

Cancel Button

The Cancel button will cancel out any changes you are currently making without saving them into memory. When you select the Cancel button, the NetCommand™ Setup will prompt you to confirm that you want to cancel the changes you are currently making. If you have selected Cancel during the Initial Setup, you can select Initial from the Edit Setup menu to go through Initial Setup again.

This page has been intentionally left blank

The NetCommand™ Setup: Setup Screens

When you first turn on your new Mitsubishi TV, the Initial Setup Screens will appear. You will need to navigate through these screens and properly setup the equipment connected to the TV in order to use NetCommand.

Language Screen

Figure 1

The Language Screen is the first screen displayed. You will need to select the language that you would like to use. When you change your selection from English to Spanish, all setup screens and menus will be displayed in Spanish.

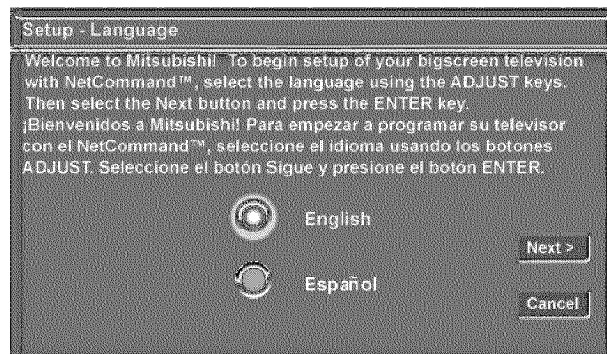

Figure 1. Setup-Language menu.

Configuration Screen

Figure 2

The Configuration Screen allows you to select which of the six configurations provided with this book you will use when connecting your equipment. You will need to choose the configuration that is closest to your current home theater setup. If you use one of the six pre-configured setups, the NetCommand™ Setup will automatically set the devices with default inputs, names and A/V settings matching the selected configuration. All you will need to supply is the manufacturer and model of your devices. You can later edit, delete or rename each device or add new devices.

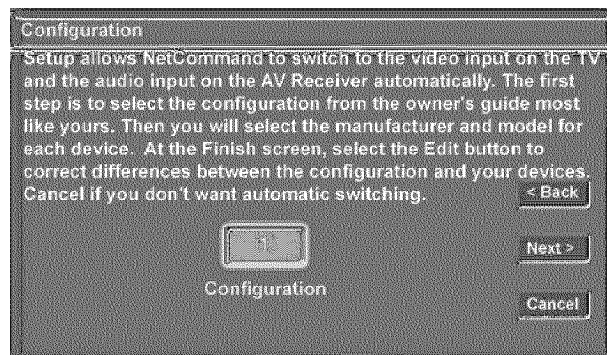

Figure 2. Configuration menu.

Of course, the NetCommand™ Setup allows you to create a custom configuration if you would like. If you choose not to use NetCommand, the NetCommand™ Setup will disappear and you will be able to use the TV in a similar method as traditional TVs.

The NetCommand™ Setup: Setup Screens

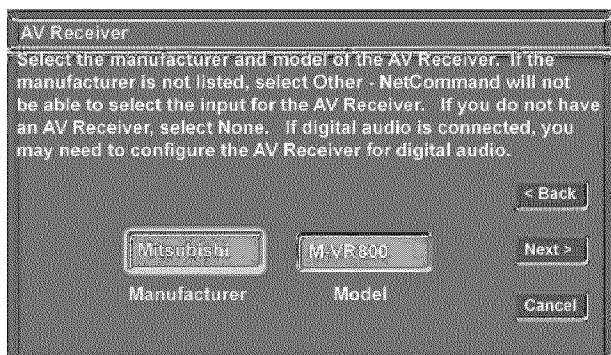

Figure 1. A/V Receiver menu.

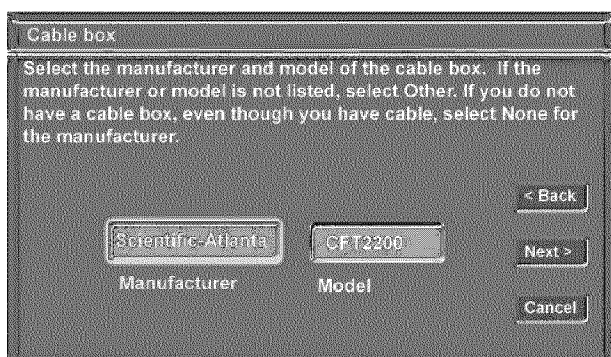

Figure 2. Cable box menu.

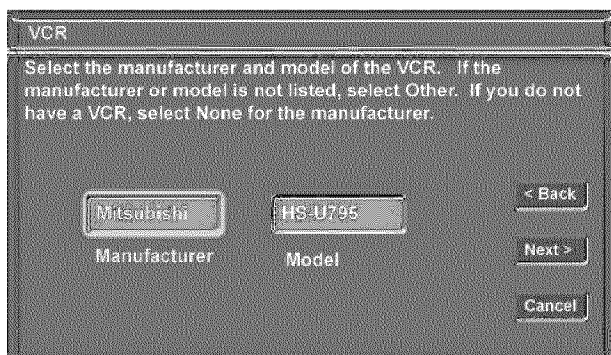

Figure 3. VCR menu.

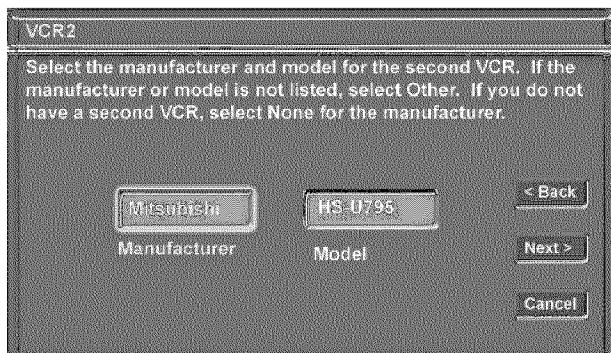

Figure 4. VCR2 menu.

A/V Receiver Screen

Figure 1

The A/V Receiver Screen allows you to select the manufacturer and model you are currently using. When you select a device, you will see the video of the device on-screen and hear the audio from the device through your A/V Receiver. When “None” is selected for the Manufacturer, you will hear sound through the TV speakers only. When “Other” is selected for the Manufacturer, no input or volume control is available. When “Other” is selected for the Model, some control may be available.

Cable Box Screen

Figure 2

The Cable Box Screen allows you to select the manufacturer and model of the cable box that you are currently using. For the Manufacturer, select “None” if you don’t have the device. If “Other” is selected for the Manufacturer, then NetCommand™ can not control the device (use the layer switch on the remote or use the remote for the device). If you have a listed Manufacturer, but not the model, then selecting “Other” for the model may allow device control.

VCR & VCR2 Screens

Figure 3 & 4

The VCR & VCR2 Screens allows you to select the manufacturer and model of the VCR or second VCR (if applicable) that you are currently using. For the Manufacturer, select “None” if you don’t have the device. If “Other” is selected for the Manufacturer, then NetCommand™ can not control the device (use the layer switch on the remote or use the remote for the device). If you have a listed Manufacturer, but not the model, then selecting “Other” for the model may allow device control.

The NetCommand™ Setup: Setup Screens

DBS Screen

Figure 1

The DBS (Digital Broadcast Satellite) Screen allows you to select the manufacturer and model of the satellite system that you are currently using. For the Manufacturer, select “None” if you don’t have the device. If “Other” is selected for the Manufacturer, then NetCommand™ can not control the device (use the layer switch on the remote or use the remote for the device). If you have a listed Manufacturer, but not the model, then selecting “Other” for the model may allow device control.

DVD Screen

Figure 2

The DVD Screen allows you to select the manufacturer and model of the DVD Player that you are currently using. For the Manufacturer, select “None” if you don’t have the device. If “Other” is selected for the Manufacturer, then NetCommand™ can not control the device (use the layer switch on the remote or use the remote for the device). If you have a listed Manufacturer, but not the model, then selecting “Other” for the model may allow device control.

Camcorder Screen

Figure 3

The Camcorder Screen allows to indicate whether or not you have a camcorder connected to the TV, or would like to reserve an input for your camcorder. Though your Camcorder cannot be controlled by NetCommand, you can still switch to the Camcorder input when you would like to view your camcorder.

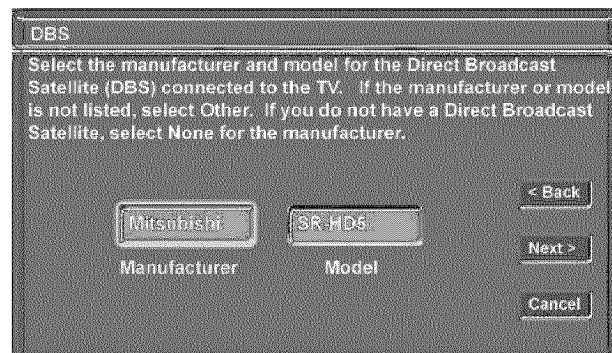

Figure 1. DBS menu.

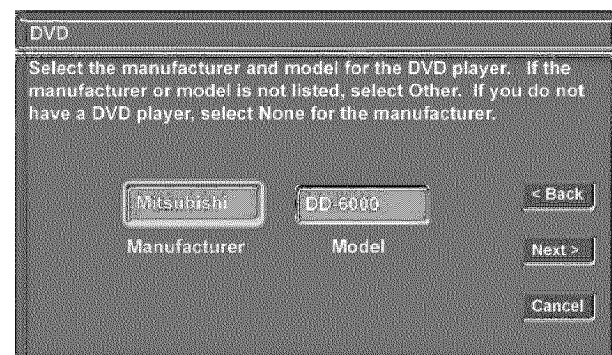

Figure 2. DVD menu.

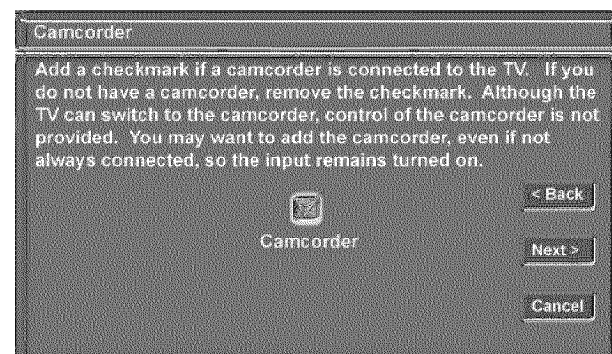

Figure 3. Camcorder menu.

The NetCommand™ Setup: Setup Screens

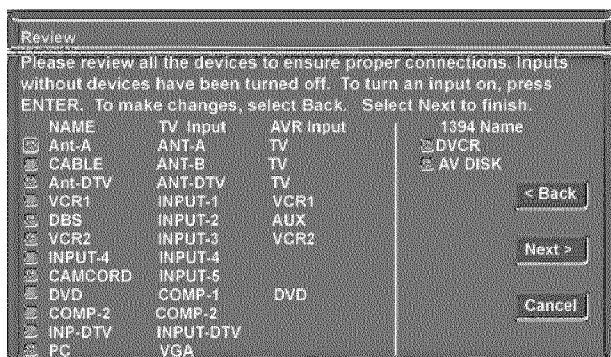

Figure 1. Review menu.

Review Screen

Figure 1

Once you have finished the setup screens and selected the manufacturer and model for each device, you will see the Review Screen. It is important to keep in mind that you are reviewing the settings that are about to be made, so you can still navigate back through the NetCommand™ Setup screens to make changes. If you select Next>, all selections made are finalized.

While viewing the Review Screen, adding or removing checks from the checkboxes on the left will turn devices (or inputs) on or off.

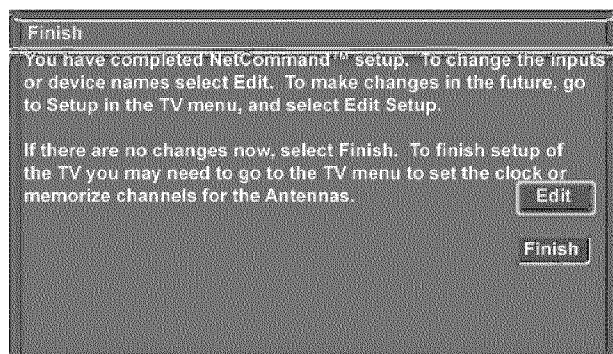

Figure 2. Finish menu.

Finish Screen

Figure 2

The Finish Screen is displayed and all selections have been finalized. Select Finish to end Setup. If you wish to change any of the preconfigured input sources for the devices, select the Edit button. You may still need to memorize the available channels for Ant-A, Ant-B and Ant-DTV by going to the Main menu and selecting antenna.

The NetCommand™ Setup: Edit Setup Screens

Bearing in mind that your home theater system will continually change as you add and remove components, Mitsubishi's NetCommand also offers ease of use when it comes to editing your home theater configuration.

Edit Setup Screen

Figure 1

When you need to make a change to your current setup, the Edit Setup Screen makes it easy. Possible choices, although not always available, are Add, Change, Delete, Review, or Initial.

Add

Figure 2

When you select Add from the Edit Screen, you will see the New Device Screen. Select the Device Type that you would like to add. Next, you will name the device and select the inputs for the TV and A/V Receiver.

Change

Figure 3

When you select Change from the Edit Screen, the Change Screen appears. You will need to select the device that you would like to change by device name. Use this to change the name or input connections to the TV and A/V Receiver for a device added through Initial Setup.

After selecting Next> from the Device or Change screen, submenus for the selected device will be displayed. These submenus are explained on pages 34-35.

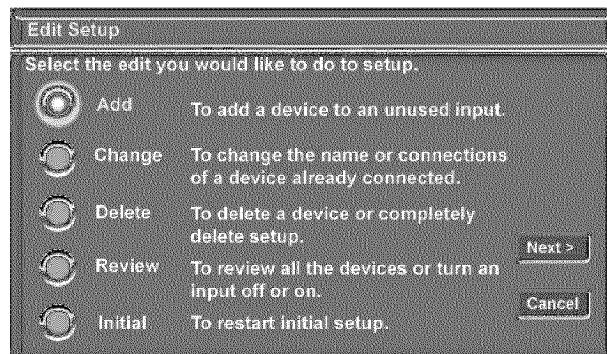

Figure 1. Edit Setup menu.

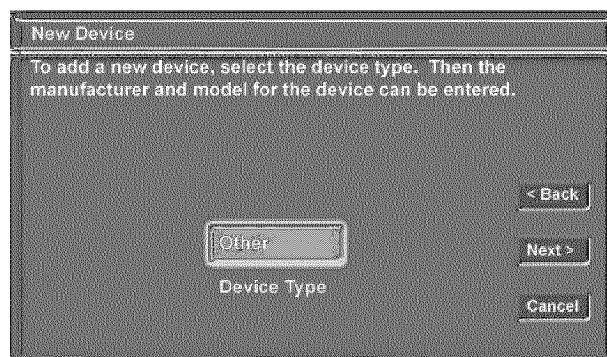

Figure 2. New Device menu.

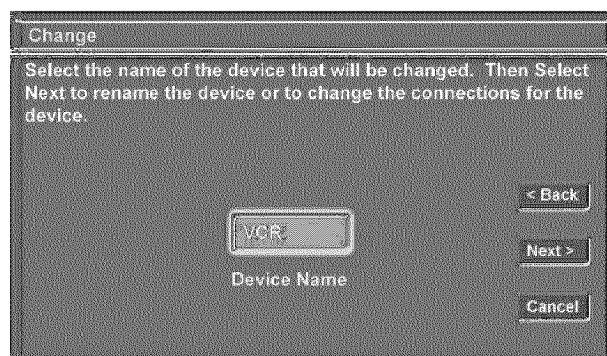

Figure 3. Change menu.

The NetCommand™ Setup: Edit Screens

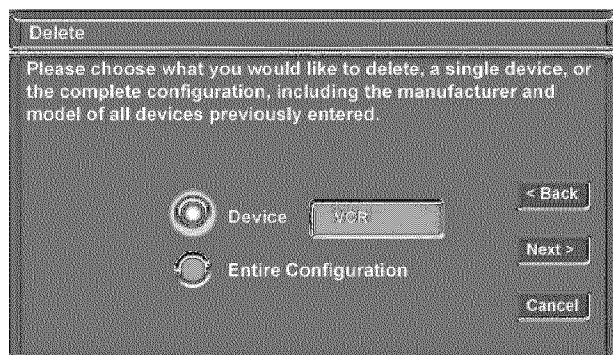

Figure 1. Delete menu.

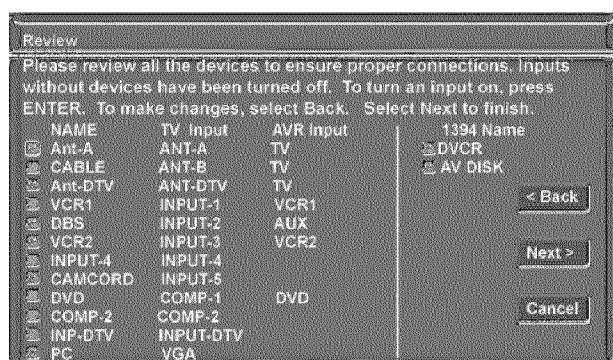

Figure 2. Review menu.

Delete

Figure 1

When you select Delete from the Edit Screen, you will see the Delete Screen. You can choose to delete just a single device by selecting the device you would like to delete, or you can delete the entire NetCommand™ Setup configuration. After you have chosen the device, or the entire configuration, the NetCommand™ Setup will prompt you to confirm your choice to delete. If you select Entire Configuration, the Initial button becomes available on the Edit Setup screen.

Review

Figure 2

When you select Review from the Edit Screen, you will see the Review Screen. This is the same Review Screen from the Initial Setup.

Initial

If, for any reason, you cancelled out of the Initial Setup before completion or if you deleted the entire configuration, selecting Initial from the Edit Screen allows you to go through Initial Setup again, starting with the Configuration screen.

(See page 28).

The NetCommand™ Setup: Edit Screens

Name

Figure 1

The Name screen allows you to change the default name for each device to a custom name of up to eight characters, selecting from letters, numbers, and nine different characters. Use ▲▼ to select each letter, then press ENTER to move to the next letter position. Press CANCEL to delete the current letter and move back one letter position. When in the *rst position*, the CANCEL button will return the name to the original default name.

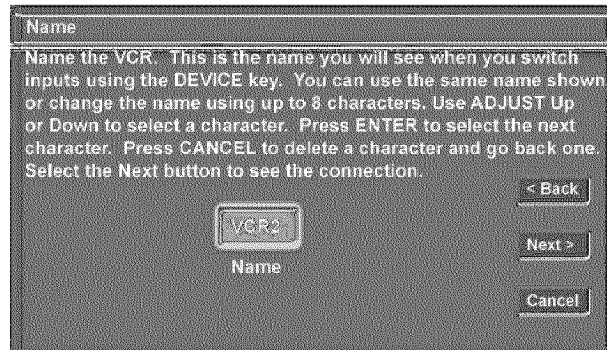

Figure 1. Name menu.

Connection

Figure 2

The Connection screen allows you to change the connections to the TV inputs and A/V Receiver inputs, and select if audio, video or both are connected to the inputs. Figure 2 uses a cable box as an example. Check the “RF” box if you send the output of your cable box to the TV on channel 3, 4, or 5. Then select the antenna and the device name for the VCR connected to the cable box. Uncheck the “RF” box if you send the audio and video to your TV and A/V Receiver using audio and video cables. When connecting other devices, the “RF” box is not displayed. If “RF” is unchecked, or for any other device, select the inputs on the TV and A/V Receiver connected to the device. Then check the “Video” and/or “Audio” boxes that match your connections.

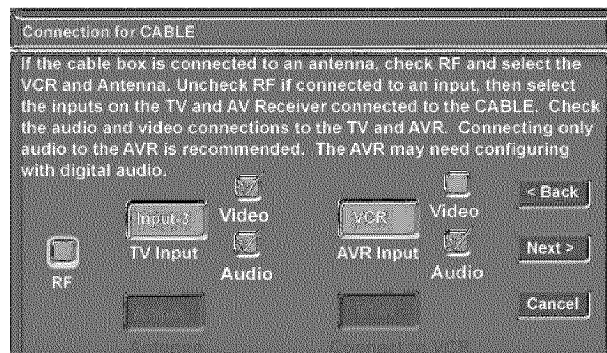

Figure 2. Connection menu.

Channel

Figure 3

If the device being connected is a cable box and the “RF” box (on the previous screen) is checked, the Channel screen allows you to select the channel number that is used for output by your cable box when the cable box is connected through Ant-A or Ant-B.

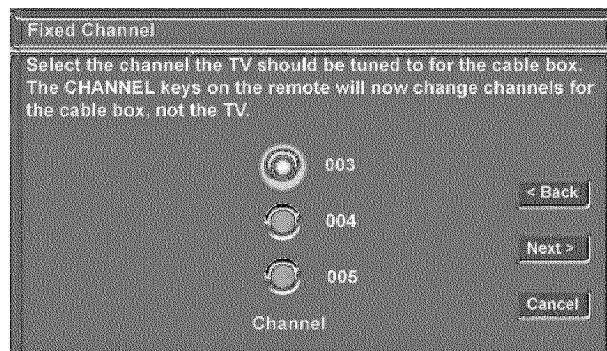

Figure 3. Channel menu.

The NetCommand™ Setup: Edit Screens

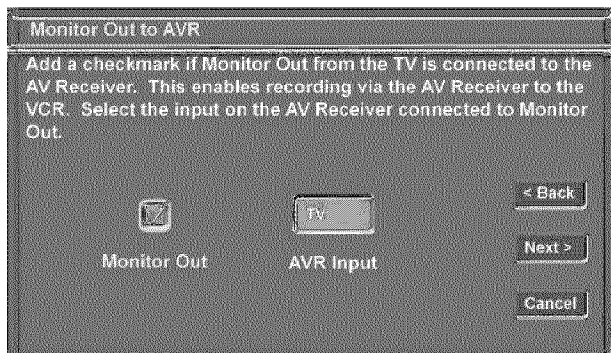

Figure 1. Monitor Out to AVR menu.

Monitor Out to AVR (or VCR)

Figure 1

This connection allows recording of signals from the TV monitor through the A/V Receiver (if connected) to an analog VCR. This screen is shown only if an A/V Receiver is the device being added or edited. If there is no A/V Receiver and VCR is being added or edited then the screen is called Monitor Out to VCR. The Monitor Out to AVR (or VCR) screen allows you to connect the connection from monitor out of the TV to the A/V Receiver (or VCR) inputs shown.

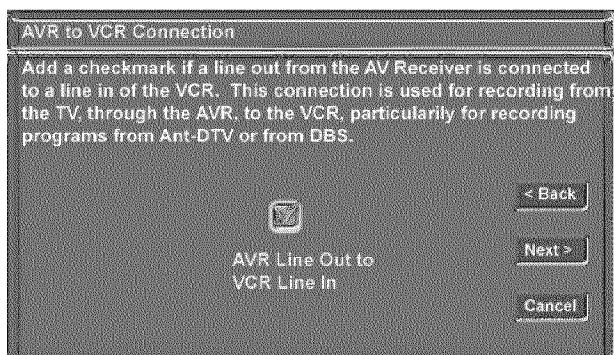

Figure 2. AVR to VCR Connection menu.

AVR to VCR Connection

Figure 2

This screen is displayed only if a VCR is the device for editing and an A/V Receiver is connected. This allows recording from devices only accessible from the TV, such as Ant-DTV and IEEE 1394. The AVR to VCR Connection screen allows you to connect the connection from the A/V Receiver to a VCR. This connection allows recording of signals from the TV monitor through the A/V Receiver to analog VCR.

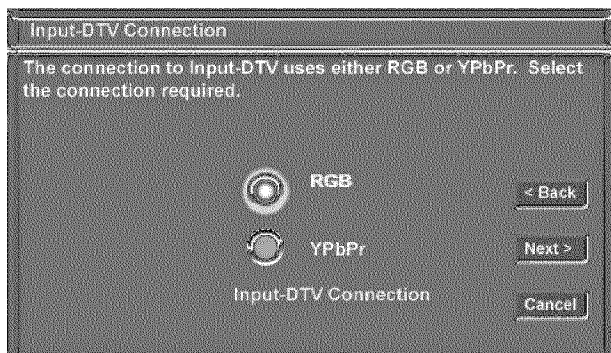
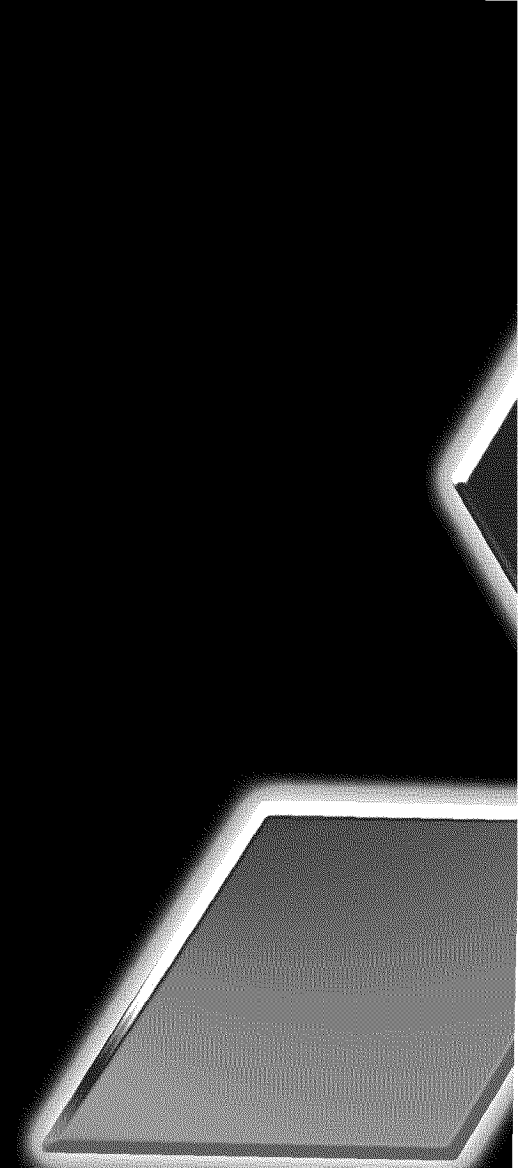

Figure 3. Input-DTV Connection menu.

Input-DTV Connection

Figure 3

This screen is displayed only if the device selected in the Connection screen is connected to Input-DTV. The Input-DTV Connection screen allows you to select which connection type you are using to connect your cable box, DBS, or HDTV Receiver when connected through Input-DTV.



Part III

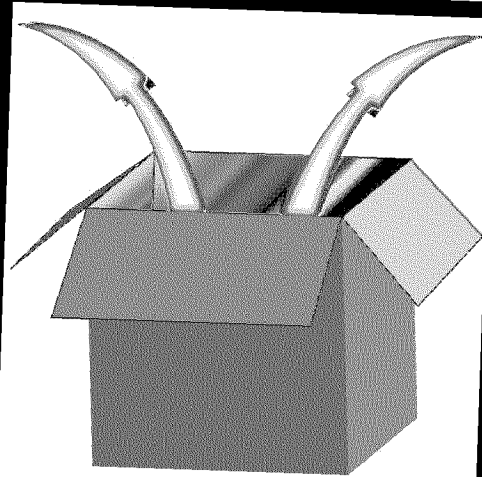

Setup

▶ViewPoint® on-screen menu system	38
Device Selection Menu	39
PIP Selection Menu	40
Menu Screens (Overview)	41-42
Setup Menu	43-45
Edit Setup & Icon Position	43
Convergence	44
Advanced Convergence, Transport Menu, Language	45
Antenna Menu	46-47
Antenna, Memorize Channels, Channel, Memory, and Name	46
Super Quick View™	47
Clock Menu	48
Captions Menu	49
V-Chip Menu	50-52
Passcode	50
V-Chip	51
Lock By Time and Front Button Lock	52
Timer Menu	53
A/V Settings Menu	54-55

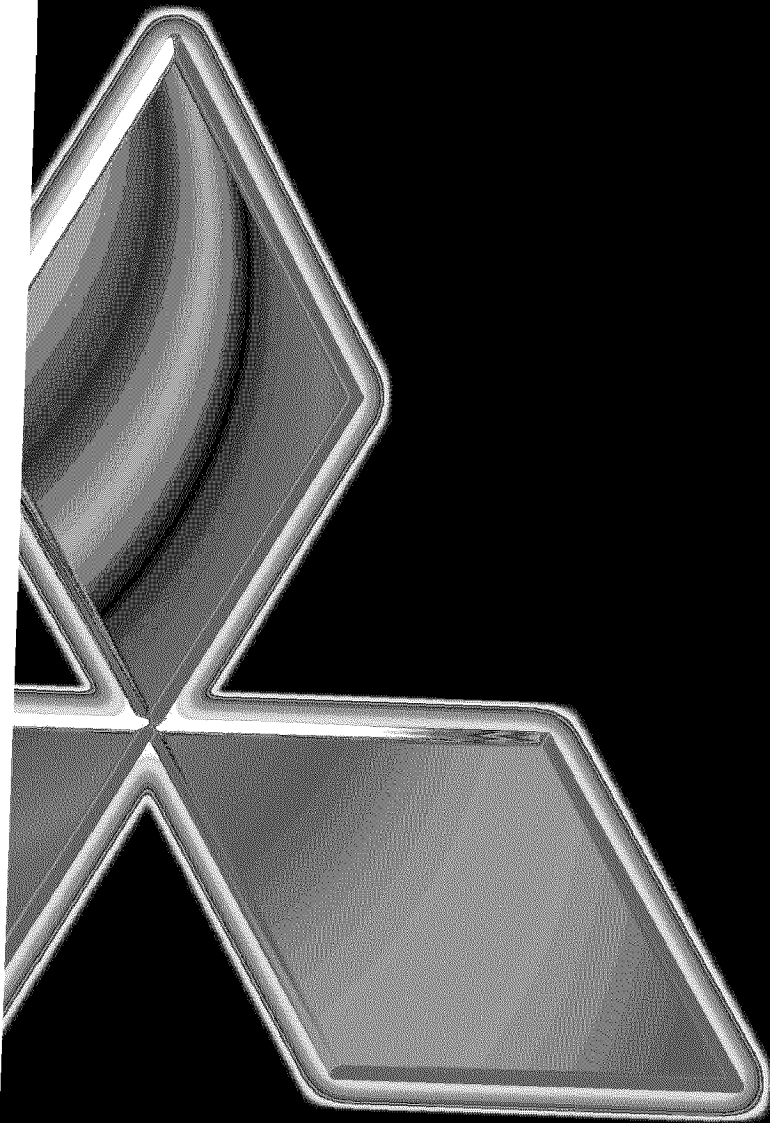

The 3D Graphical **ViewPoint**® Menu System

Your TV has a special control system called NetCommand™ that will control IEEE 1394 devices and selected older devices. For instructions on operating these control features, see the NetCommand™ guide.

Your TV also has Mitsubishi's exclusive 3D Graphical **ViewPoint**® on-screen operating system, which provides on-screen information for menu choices and changes (Figure 1).

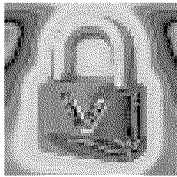

A picture (icon) will be highlighted when selected with the ADJUST arrows. When selected, the appropriate menu will appear. You may then make changes within the menu or access sub-menus, if available.

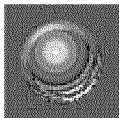

You may also access submenus from a button. Sometimes a selection of the button will start an automatic function.

The **ViewPoint**® system includes the following special features:

- ➔ The currently selected icon or button is highlighted with a yellow outline and the text color will be yellow.
- ➔ On-screen instructions provide complete menu choice information.
- ➔ Some on-screen menu options must be set before other options are available. For example, the "Timer" can be set and turned "on" only after "Set Time" and "Set Day" have been set in the "Clock" menu.

The following buttons on your remote control will help you to navigate within the **ViewPoint**® system (Figure 2):

- 1** ADJUST ◀ or ▶ to select the menu item you want to change.
- 2** ADJUST ▲ or ▼ to change the settings.
- 3** ENTER to enter into a menu, start an automatic function, or select a checkbox.
- 4** CANCEL to clear a setting, or stop an automatic function.
- 5** MENU to move back one menu screen at a time.
- 6** HOME to exit all menus and return to TV viewing.

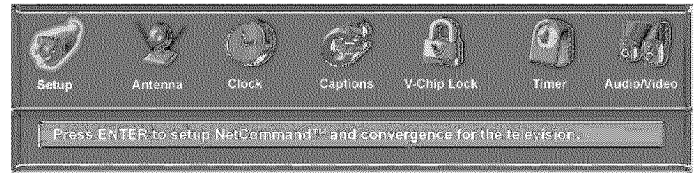

Figure 1. Main Menu: The Main Menu screen will always be the first screen that appears when you press the MENU button.

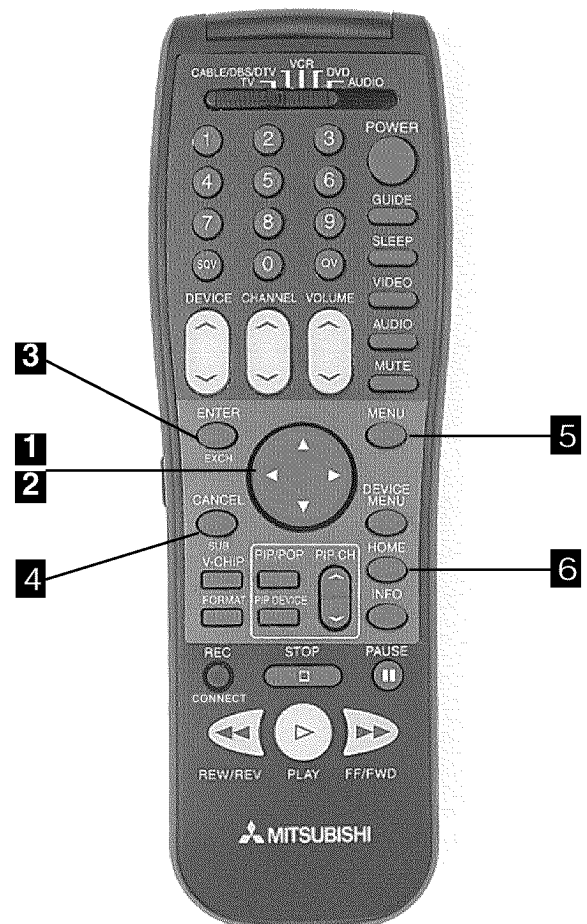

Figure 2. These buttons are used for navigation within the **ViewPoint**® on-screen operating system.

Device Selection Menu

When you press the DEVICE button on your remote control, the Device Selection Menu will appear. The Device Selection Menu allows you to select the device for viewing, select audio from the TV speakers or the A/V Receiver, power devices on or off, verify the destination of signals, or cancel recordings and peer-to-peer connections.

Selecting Devices

When the Device Selection Menu is displayed, the device you are currently viewing will show a gold-colored icon. To select another device, use the ADJUST button to move the yellow highlight among the devices. Press ENTER to select the device you would like to view and hear. Then the TV and A/V Receiver inputs are automatically changed.

Power On/Off of Selected Device

When the Device Selection Menu is displayed, you can turn on or off the power of the highlighted (yellow outline) device by pressing the POWER button on the remote control. If the POWER button is pressed when the Device Selection Menu is not displayed, the TV will be powered on or off.

Destination Display

The TV icon is always the destination for the currently selected device. As you move the highlight in the video section to different devices, new icons may appear which are the destinations of recordings or peer-to-peer connections for the highlighted video device.

Selecting Audio Output

When a NetCommand compatible legacy IR controlled A/V Receiver, or HAVi ampli ϵ has been connected to the TV and added by the NetCommand Setup, an icon for this device will appear in the audio section. Use the AUDIO button to change navigation to the audio section. Then use the arrow buttons to select the TV speakers icon or the A/V Receiver icon. Press ENTER to change the audio selection. Use the VIDEO button to return navigation to the video section.

Cancel Recordings or Peer-to-Peer Connections

If the destination shows that a recording or peer-to-peer connection is active for the highlighted source, press CANCEL to stop the recording or end the peer-to-peer connection.

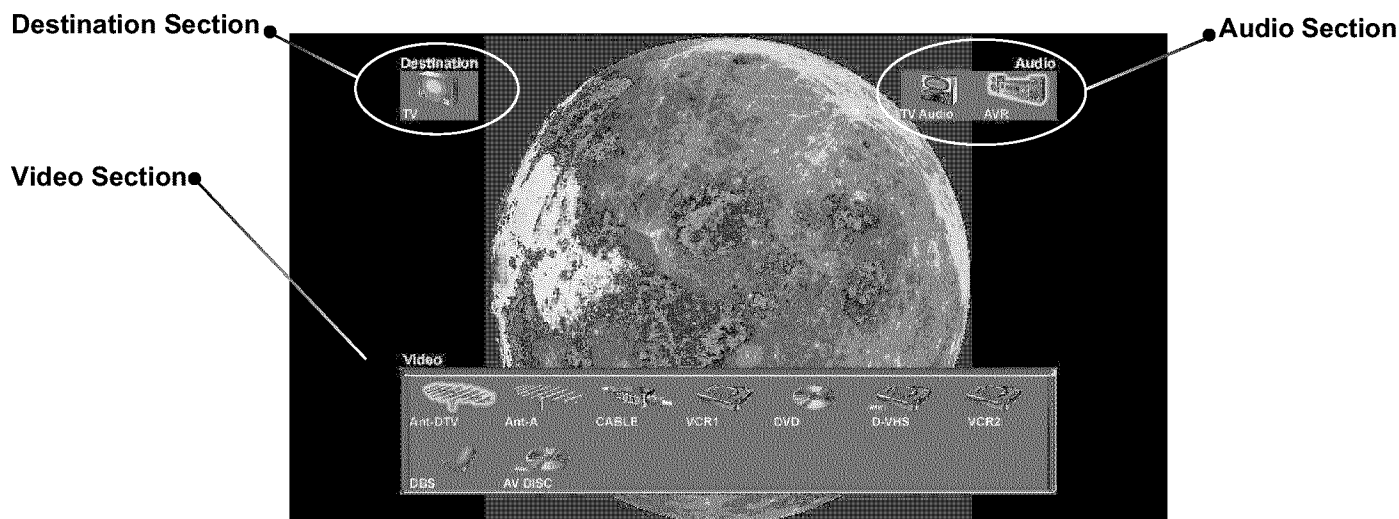

Figure 1. Device Selection menu.

PIP Selection Menu

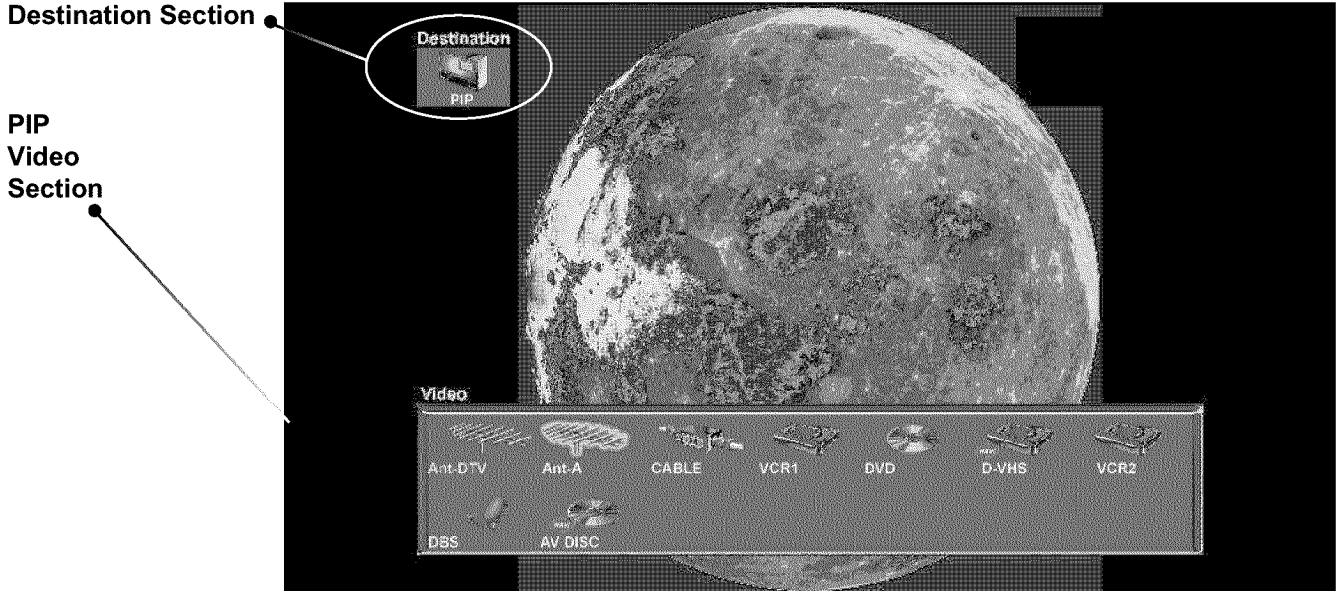

Figure 2. PIP Selection menu.

Selecting Device for PIP

(Figure 2)

When the PIP DEVICE button on the remote control is pressed, the PIP Selection Menu displays. The PIP Selection Menu is similar to the Device Selection Menu except the source for the sub picture is selected and the audio display and selection are not supported.

Menu Screens (Overview)

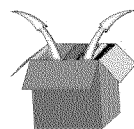

Setup Menu

(Figure 1)

You can add, change, review or delete device settings, change the order of icons displayed on the Device Selection Menu, select convergence adjustment, turn on or off the transport menu, and select English or Spanish as the language for the menus and on-screen displays.

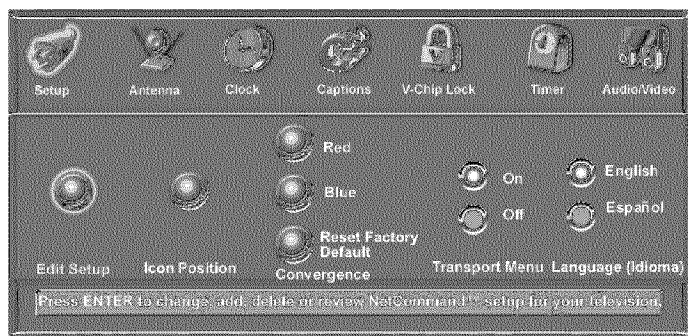

Figure 1. Setup menu

Antenna Menu

(Figure 2)

Use to memorize locally available channels for Ant-A, Ant-B and Ant-DTV, manually add or delete channels from memory, name channels for Ant-A and Ant-B, or add your favorite channels to a SQV (Super Quick View™) list.

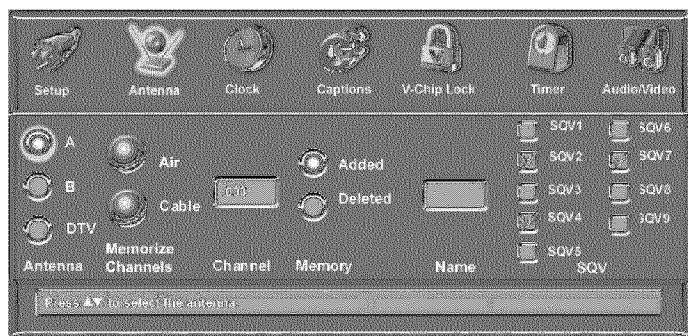

Figure 2. Antenna menu

Clock Menu

(Figure 3)

Manually set the time for the TV, or select Auto and the TV will automatically set the time based upon Extended Data Service (XDS) time data. This time data is usually broadcast by your local PBS station.

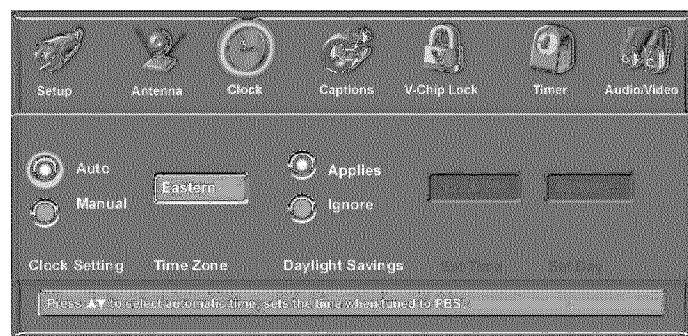

Figure 3. Clock menu (Auto)



Menu Screens (Overview)

Captions Menu

(Figure 1)

Display closed captions or text, choose black or gray as the background color for the closed caption area, and turn on or off the Digital Channel guide.

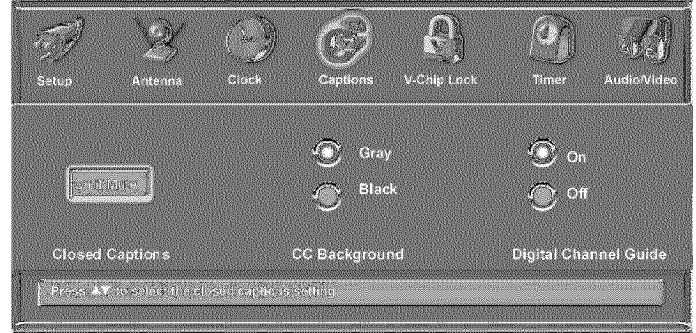

Figure 1. Captions menu

V-Chip Lock Menu

(Figure 2)

Block or allow programming based upon rating signals sent by the broadcast station, lock by time, or enable or disable the front panel buttons.

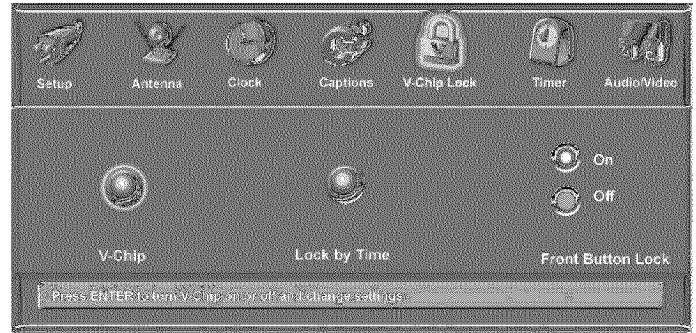

Figure 2. V-Chip Lock menu

Timer Menu

(Figure 3)

Set your TV to tune to a pre-selected device and channel and turn on if the TV is off.

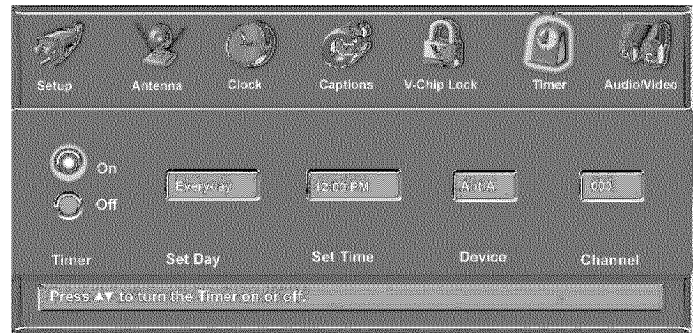

Figure 3. Timer menu

Audio/Video Menu

(Figure 4)

A/V Memory Reset allows you to return A/V settings to the original factory settings for the selected device. Or use A/V Reset on the front panel to reset all devices at one time. You can also adjust some or all of the A/V settings, display a blue screen when viewing a device with no signal, choose to enhance the darker parts of bright pictures or turn speakers on or off.

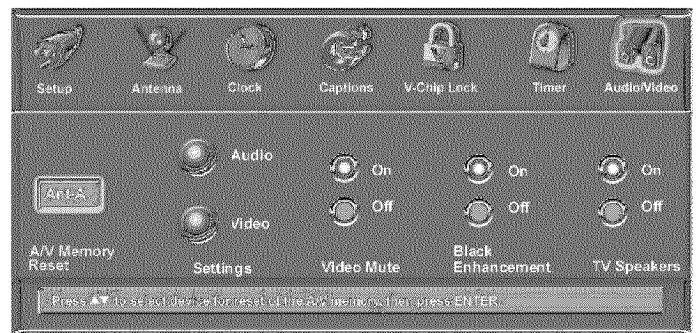

Figure 4. Audio/Video menu

Setup Menu: Edit Setup and Icon Position

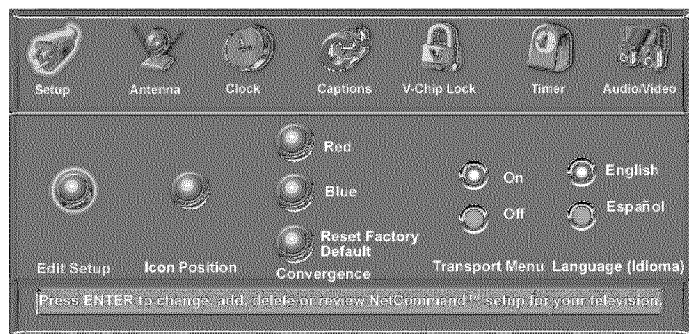
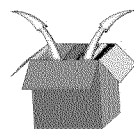

Figure 1. Setup menu

Edit Setup Button

(Figure 1)

The Edit Setup button displays the Edit Setup Menu (refer to Page 32). Edit Setup provides the following options:

- ➔ ADD - Addition of new devices.
- ➔ CHANGE - Change or edit devices, both older traditional devices and 1394 devices.
- ➔ DELETE - Delete a single device or delete the entire setup configuration.
- ➔ REVIEW - Review all devices connected to the TV, including 1394 devices and turn devices and unused inputs on and off.
- ➔ INITIAL - Allows initial setup, in the event setup has never been completed or if the entire configuration was deleted.

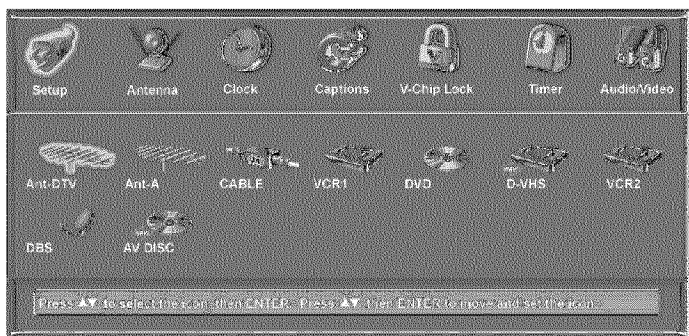

Figure 2. Icon Position menu

Icon Position Button

(Figure 2)

Icon Position allows you to arrange the device icon order on the Device Selection Menu to your preferred sequence to make the operation of the TV easier.

Use ADJUST ▲, ▼, ◀, or ▶ to highlight the icon to be moved and then press ENTER to select the icon. Use ADJUST ▲, ▼, ◀, or ▶ to move the icon to the desired position and then press ENTER to secure the icon in the new position.



Setup Menu: Convergence

Convergence

(Figure 1)

Your Mitsubishi TV has three picture tubes which need to be aligned to properly converge the projected light beams on the screen. Each picture tube projects a single color of red, blue or green. During production, your TV was carefully adjusted to properly align these colors. However, moving the TV, or the TV's location in relation to the Earth's magnetic poles, or the passage of time can cause these adjustments to change. As a special feature, you have the ability to adjust the red and blue light beams in reference to the red green light beam. This process is called convergence adjustment. Since the memory for the convergence is separate for 480i/480p and for HD 1080i signals, you may need to adjust the convergence while watching each of these types of signals.

Reset Factory Defaults

(Figure 1)

This allows you to reset the convergence to the original factory settings. The message "Convergence reset completed" will be displayed when the factory defaults have been restored.

Convergence Screen

(Figure 2)

When the Red and Blue crosshairs are properly converged, the center-screen crosshairs will appear white. You can use ▲, ▼, ◀, or ▶ to move the Red and Blue crosshairs. Press VIDEO to switch between Red and Blue. Press AUDIO for the Advanced Convergence screen, and see *Advanced Convergence*, page 45, for instructions.

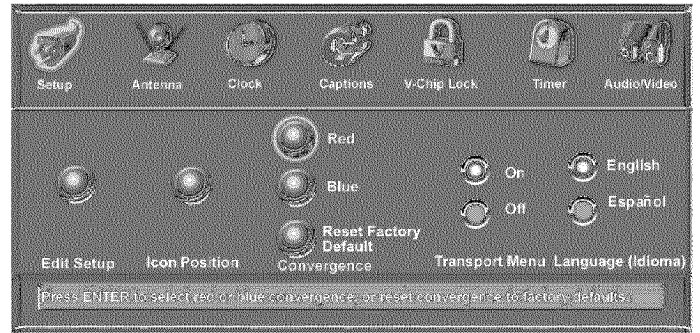

Figure 1. Setup menu, (Convergence selected)

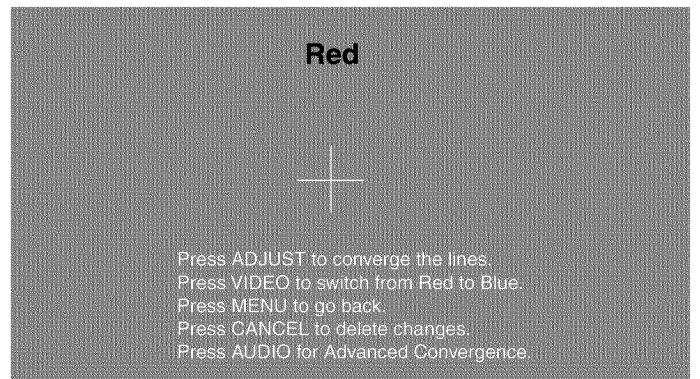

Figure 2. Convergence screen

Setup Menu: Advanced Convergence, Transport Menu, and Language

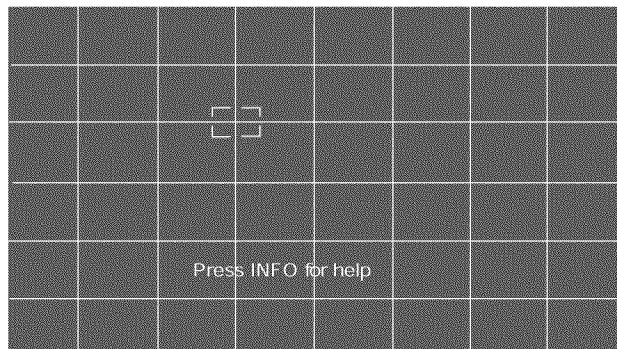
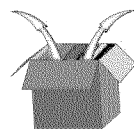
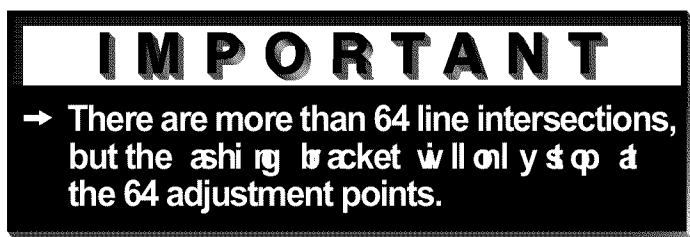

Figure 1. Advanced Convergence screen



Advanced Convergence

(Figure 1)

After adjusting the Red Convergence and Blue Convergence, you can re-tune your TV by adjusting the Red and Blue convergence at 64 individual points. Move the white bracket to a position needing adjustment by pressing ▲, ▼, ◀, or ▶. Press ENTER to select the position (the white line stop). Move the Red or Blue line by pressing ▲, ▼, ◀, or ▶. Press VIDEO to switch between the Red and Blue lines. A position is properly converged when all three lines combine to appear white. Press ENTER to deselect the position (the white line will resume), and move the brackets to the next position needing adjustment. When completed, press MENU or HOME to save your changes, and exit the Advanced Convergence screen. Press INFO for detailed instructions and then press INFO or menu to return to the convergence screen.

Transport Menu

(Figure 2)

The Transport Menu is used by NetCommand™ to control VCRs, DVDs, IEEE 1394 AV Disc, digital VCRs, and similar devices. This menu can be turned off if you would rather not have it displayed. The transport buttons on the remote control will continue to operate. See the NetCommand Guide for further details.

Language

(Figure 2)

Display the on-screen menus in either English or Spanish (Español). The first time your TV was powered on, you were requested to select an on-screen menu language. When the radio button setting is changed, the screen language changes concurrently.

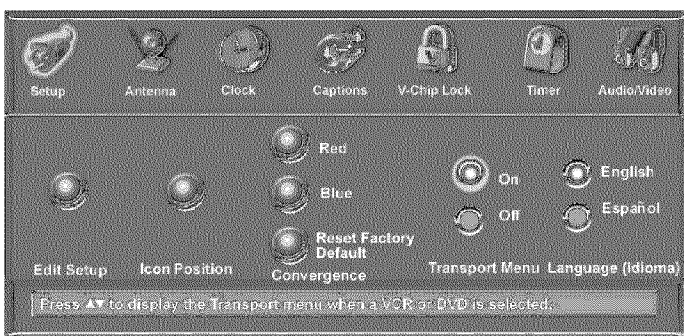

Figure 2. Setup menu (Transport menu selected)



Antenna Menu: Antenna, Memorize Channels, Channel, Memory, and Name

Antenna

(Figure 1)

Select Ant-A, Ant-B, or Ant-DTV. For each antenna, you can memorize, add or delete channels in memory and add channels to the SQV (Super Quick View™) list. For Ant-A and Ant-B, you can name channels.

Memorize Channels

(Figure 1)

First select either air or cable (if direct cable to TV is used), then press ENTER. This selection will allow you to memorize the channels your TV can receive in your area. You can stop memorization at any time by pressing CANCEL. Channels memorized prior to pressing CANCEL will stay in memory. After channels are memorized, you may select memorized channels in ascending or descending order by pressing the CHANNEL button on the remote control. If memorizing Cable for Ant-DTV a pop up selection for the cable type of Standard, HRC or IRC is displayed. Use ADJUST ▲ or ▼ to select the type, then press ENTER to begin memorization. If you do not know the type for your cable, contact your cable company.

Channel

(Figure 1)

Select the channel you want to add or delete from memory, name, or add to the SQV Super Quick View™ list.

Use ADJUST ▲ or ▼ to select the channel for editing or use CHANNEL button for only those channels already in memory.

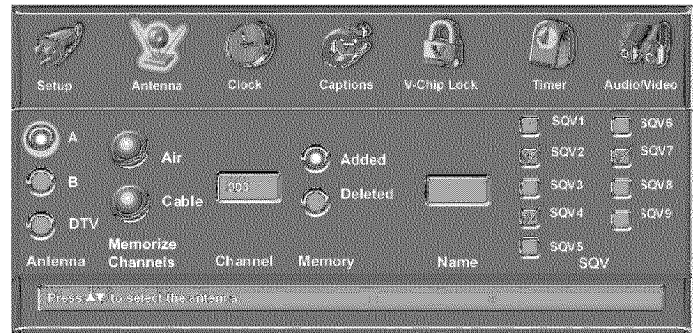

Figure 1. Antenna menu

Memory

(Figure 1)

After the available channels have been memorized with *Memorize Channels*, weaker channels viewed with Ant-A or Ant-B can be added. Unwanted channels for Ant-A, Ant-B, or Ant-DTV can also be deleted. Use the CHANNEL button on the remote control to see the channels in memory.

Use Adjust ▲ or ▼ to select Added or Deleted for the channel shown in the “Channel” option box.

Name

(Figure 1)

Channels shown on Ant-A or Ant-B can be named (up to four characters). After you enter a name, it will appear on the TV screen, next to the channel number. Use Adjust ▲ or ▼ to select each letter then press ENTER to move to the next letter position. Press CANCEL to move back one position. Pressing CANCEL while in the 1st position will cancel the entire name. The possible letters/characters are A-Z, 0-9, and the following characters: ! . & ' / : * - and blank.

Antenna Menu: Super Quick View™ (SQV™)

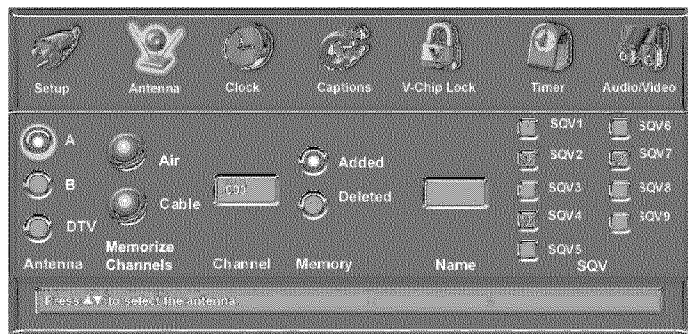
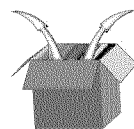

Figure 1. Antenna Menu

SQV (Super Quick View™) Using The Menu Screen

(Figure 1)

SQV (Super Quick View™) allows you to put together a list of your favorite channels from Ant-A, Ant-B and Ant-DTV. You can store channels in each of the 9 different memory banks. Also, you can store the same channel in multiple memory banks. Once you have added a channel to the SQV memory, when tuned to the channel “SQV” (and the memory bank number) will appear under the channel number on the TV screen.

- 1 Select the channel using the “Channel” option box or CHANNEL button.
- 2 Use ▼▲◀▶ to select the SQV Memory Bank.
- 3 Press ENTER to check mark the memory bank.
- 4 Repeat for additional channels or banks.

Removing SQV Channels

- 1 Highlight the check marked box.
- 2 Press ENTER to remove the check mark.

SQV (Super Quick View™) Using The Remote Control

Viewing and changing SQV banks using the remote control:

- 1 Press the SQV button.
- 2 To change memory banks, press a number button within 5 seconds of pressing the SQV button.
- 3 Press the SQV button repeatedly to cycle through the channels available in that bank.

Adding SQV channels using the remote control:

- 1 Use the CHANNEL or number buttons to select the channel you want to add to the current SQV memory bank.
- 2 Press and hold the SQV button for about 2 seconds. When “SQV” and the memory bank number appear under the channel number, the channel has successfully been added.

Removing SQV channels using the remote control:

- 1 Press the SQV button repeatedly until you see the desired channel.
- 2 While the channel number and SQV indicator (with correct bank number) are still displayed on the screen, press the CANCEL button. If the CANCEL button is not pressed before the SQV indicator disappears automatically, the channel will not be removed.
- 3 When the SQV indicator disappears, the channel has successfully been removed only for that bank. Other banks remain unchanged.



Clock Menu: Auto or Manual Clock Setting

Clock Setting (Auto)

(Figure 1)

The Clock Setting of Auto will automatically set the day and time using Extended Data Service (XDS) time data. This data is automatically retrieved from a PBS channel or other channel carrying this service when received on Ant-A or Ant-B.

Time Zone

(Figure 1)

When Auto has been selected for the Clock Setting, you need to select the correct time zone. Use ADJUST ▲ or ▼ to select the time zone (Atlantic, Eastern, Central, Mountain, Pacific, Alaska, or Hawaii) for your area. Then use ADJUST ► to move to the Daylight Savings Time option.

Clock Setting (Manual)

(Figure 2)

For the manual clock setting, select the current time, including AM or PM and the day.

Set Time

(Figure 2)

When manual has been selected for the clock setting, you need to set the time. Press ▲ or ▼ to slowly adjust the time. Press and hold ▲ or ▼ to quickly adjust the time. Then use ► to move to the “Set Day” option.

Set Day

(Figure 2)

When Manual has been selected for the Clock Setting, you need to select the current day of the week. Use ▲ ▼ to select the correct day.

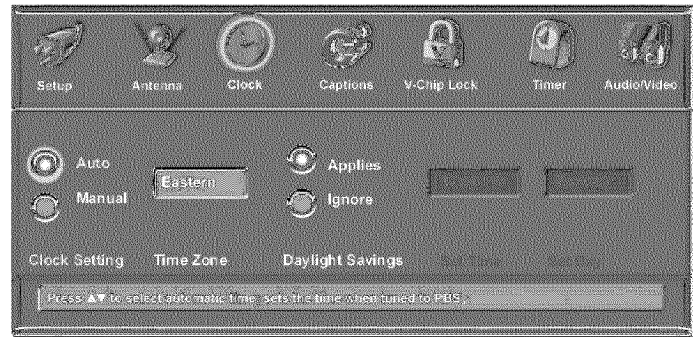

Figure 1. Clock Menu (Auto)

Daylight Savings Time

(Figure 1)

When Auto has been selected for the Clock Setting, you need to select the Daylight Savings Time (DST) option that your state uses. Use Adjust ▲ or ▼ to select Applies if your state uses DST, or Ignore if your state or area does not use DST. The clock time and day will be set automatically after tuning to a channel carrying the Extended Data Service (XDS) time data (usually your local PBS channel).

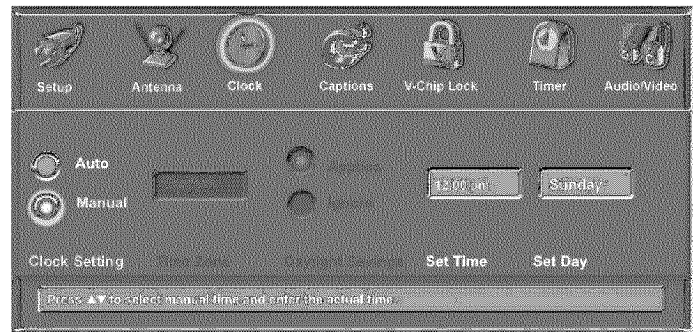

Figure 2. Clock Menu (Manual)

Captions Menu: Closed Captions

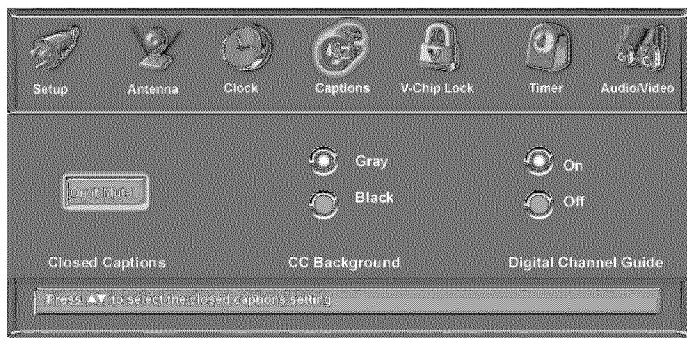

Figure 1. Captions menu

Captions Menu

(Figure 1)

Broadcasters can send either Standard or Text closed captioning. Standard closed captioning follows the dialogue of the characters on-screen and displays in a small section of the screen. Text closed captioning often contains information such as weather or news and covers a large portion of the on-screen program. Your TV can decode four different standard and four different text closed captioning signals from each TV station. However, each TV station may broadcast only one or two closed captioning signals, or none at all.

Within the Captions menu, you can turn on or off the closed caption decoder, select the type of captions or text, choose black or gray as the background color for the closed caption area, or select the Digital Channel Guide.

IMPORTANT

- When Text closed captioning is selected, a large black or gray box will appear on your TV screen if no signal is broadcast.

Closed Captions

(Figure 1)

The TV can display one of the following:

- CC1, CC2, CC3, or CC4 (Standard closed captioning signals).
- Text1, Text2, Text3, or Text4 (Text closed captioning signals).
- On if mute. Closed captions when mute. When selected, the standard closed captioning signal (CC1) will turn on/off by pressing the MUTE button on the TV remote control.
- Off. No closed captions.

CC Background

(Figure 1)

To make the closed captions easier to read, you can choose to display the background color as either black or gray.

Digital Channel Guide

(Figure 1)

Select ON to display the Digital Channel Guide automatically for the following devices:

- Ant-DTV
- digital recorders
- 1394 cable box

(See NetCommand Guide)

IMPORTANT

- The content of captions is determined by the broadcaster. If your captions show strange characters, misspellings, or odd grammar, it is not a malfunction of the TV.

IMPORTANT

- Not all types of closed captions from digital channels will be compatible with the closed caption decoder in this TV.

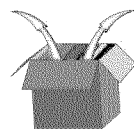

V-Chip Lock Menu: Passcode Entry

(Figures 1)

The first time you select V-Chip Lock from the MAIN menu, or after you have canceled your passcode you will see the screen shown in Figure 1. After setting a passcode, the next time you select V-Chip Lock from the MAIN menu, you will see “a new” replaced by “your.” Use the number buttons on the remote control to input a four-digit passcode, then press ENTER. You can delete a number and move back one space by pressing CANCEL. You can exit without inputting a passcode by pressing MENU or HOME.

Passcode Screen

(Figure 2)

To view a V-Chip blocked program or to watch the program during a scheduled lock time, you must enter your 4-digit passcode or change the channel to an unlocked program. Once you have entered the passcode, the V-Chip block or Lock by Time will remain released until the TV is powered off and then on again.

V-Chip

(Figure 3)

V-Chip allows you to Block or Allow programs based upon rating signals sent by the broadcasting station. The TV comes from the factory with the V-Chip in the Off setting. You can turn the V-Chip on within the V-Chip Menu or you can use the V-CHIP button on the remote control to conveniently turn the V-Chip on or off. The factory preset is TV-PG for TV ratings or PG for movie ratings, allowing only programs rated TV-PG/PG or lower. You can change the blocking level to various TV ratings and lettered categories or movie ratings. After changing channels or devices, there may be up to a 5 second delay before the V-Chip lock takes effect.

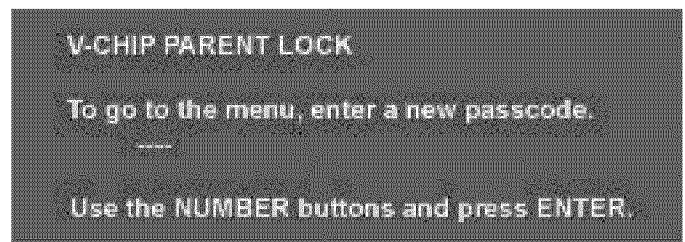

Figure 1. V-Chip Entry Screen

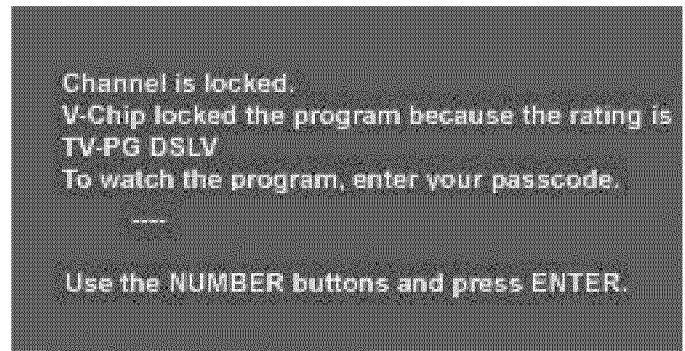

Figure 2. V-Chip Blocked Channel passcode screen



Figure 3. V-Chip menu

V-Chip Start Time and V-Chip Stop Time

(Figure 2)

Select the times you would like the V-Chip to be Active. By setting the V-Chip Start Time and V-Chip Stop Time to the same time, the V-Chip will be active 24 hours a day.

Press ▲ or ▼ to slowly adjust the time. Press and hold ▲ or ▼ to quickly adjust the time.

I M P O R T A N T

→ If you forget your four-digit passcode, see *Appendix A*, page 71.

V-Chip Lock Menu: V-Chip

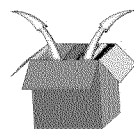

V-Chip Signal Information

When provided by the broadcaster, V-Chip ratings can be used to control which programs can be viewed or will be blocked. When V-Chip ratings are sent, you will see the ratings when you change the channel or when you press the INFO button on the remote control.

The V-Chip ratings information can be divided into two classifications, TV Ratings that include Content Categories and Movie Ratings. These are explained below.

TV Ratings:

Used with TV programs and made for TV movies.

- TV-Y** Youth, designed for children under the age of 7.
- TV-Y7** Youth, 7 years old and older. Designed for children 7 years old and older.
- TV-G** General Audience. Designed for the entire family to view.
- TV-PG** Parental Guidance. Parental Guidance is recommended, may not be suitable for some children.
- TV-14** Adolescent 14 years old and older. Not recommended for children under the age of 14.
- TV-MA** Mature Audience. Recommend for adults only.

Content Categories:

Used in association with the TV ratings above.

- FV** Fantasy Violence- applies to TV-Y7 only.
- D** Sexual Dialog- applies in different degrees to TV-PG and TV-14.
- L** Adult Language- applies in different degrees to TV-PG, TV-14, and TV-MA.
- S** Sexual Situations- applies in different degrees to TV-PG, TV-14, and TV-MA.
- V** Violence (graphic or realistic)- applies in different degrees to TV-PG, TV-14, and TV-MA

TV Rating	FV	D	L	S	V
TV-Y					
TV-Y7	X				
TV-G					
TV-PG		X	X	X	X
TV-14		X	X	X	X
TV-MA			X	X	X

Movie Ratings:

Used with theater released movies and direct-to-video movies.

- G** General Audience- Designed for the entire family to view.
- PG** Parental Guidance- Parental Guidance is recommended, may not be suitable for some children.
- PG-13** Parental Guidance 13 years old and older- Not recommended for children under the age of 13.
- R** Restricted- Restricted in the theater to 17 years old and older unless accompanied by an adult.
- NC-17** No Children- Restricted in a theater to 18 years old and older.
- X** Adult- Designed for and restricted in the theater to adult audiences only.

Programs Not Rated: Used for programs that are not rated like news, sports, weather, emergency bulletins, or movies such as those prior to or without MPAA Ratings. This does not include programs without V-Chip signals.

IMPORTANT: If you select to block programs that carry the V-Chip rating "Programs Not Rated, you may block news or emergency bulletins. Care should be used when blocking not rated programming.

When you select a TV or Movie rating, you are selecting the highest level of program that will be allowed to be viewed. As an example, if you select TV-PG, you are allowing programs rated TV-Y, TV-Y7, TV-G and TV-PG to be seen and blocking programs rated TV-14 and TV-MA. If you select a movie rating of PG-13, you are allowing movies rated G, PG and PG-13 to be seen and blocking movies rated R, NC-17, and X. When you select a TV Content category, you will block all TV programs that have the same content category listing. As an example, if you select to block V (Violence) at the TV-14 level, you will also block any program that has the V category listing at the TV-PG rating level.

IMPORTANT: V-Chip is effective only for programs viewed on Ant-A and Ant-B or from devices connected to Inputs 1-5. It is not effective for programs viewed on Ant-DTV or devices connected to Component 1 and 2, INP-DTV or from IEEE 1394 devices.

IMPORTANT: Videotapes, laser discs, and DVD's may not contain V-Chip rating signals, in this case V-Chip cannot block the program or movie.

IMPORTANT: Broadcasters are not currently required to include V-Chip rating signals at this time. If the broadcaster does not include the V-Chip rating signal, V-Chip cannot block the program.



V-Chip Menu: Lock By Time and Front Button Lock

Lock By Time

(Figure 1)

LOCK BY TIME will allow you to lock the entire TV during speci chour s

Use ADJUST ▲ or ▼ to select ON or OFF then use ADJUST ► to move to the “Lock Time” option box.

Lock by Time, Lock Time, and Unlock Time

(Figure 1)

Lock by Time locks the entire TV based upon the Lock Time and Unlock Time. You must input your 4-digit passcode to use the TV when it is locked. By setting the Lock Time and Unlock Time to the same time, the Lock by Time will be active 24 hours a day.

Use ADJUST ◀ or ▶ to select Lock by Time. Use ADJUST ▲ or ▼ to select the time the lock will start. Then use ADJUST ► to move to the Unlock Time option box. Use ADJUST ▲ or ▼ to select the time the lock will stop.

Front Button Lock

(Figure 2)

Front Button Lock lets you disable controls on the front panel to prevent young children from changing settings by accident.

Select ON to lock out the operations of the front panel button and select OFF to restore the operations of the front panel buttons. If the front panel buttons have been locked and you misplace the remote control, you can restore the function of the front panel buttons by pressing and holding the MENU button on the front panel for more than 8 seconds. If the TV is already on, a message will be displayed to con rmt he r d ease of the Front Button Lock.

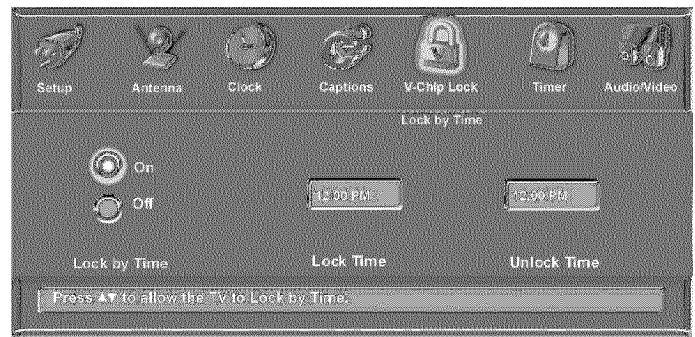

Figure 1. Lock by Time menu

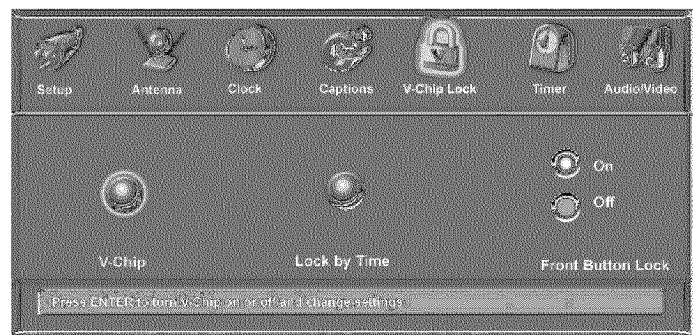

Figure 2. V-Chip Lock menu

Timer Menu: Setting The Timer

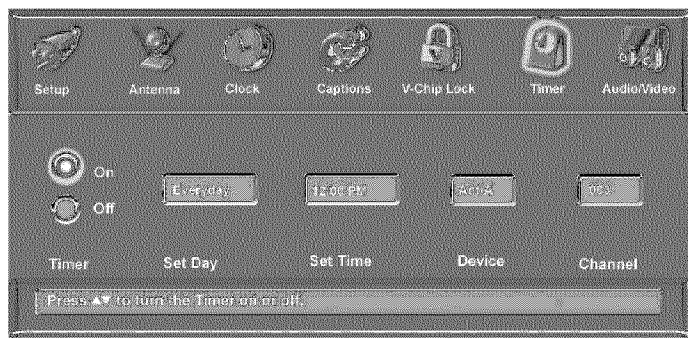

Figure 1. Timer menu

IMPORTANT

→ The TV's clock must be set before you can set the timer. If you have not set the clock, you will see the CLOCK menu instead of the TIMER menu.

Timer On/Off

(Figure 1)

The timer can be turned On or Off. When On, you need to select the time to turn on, the day to turn on, the device and the channel to display. At your preselected time, the timer will turn the TV on, and a message will be displayed, "Press a key for the TV to stay on". Any button on the remote control must be pressed within 5 minutes, or the TV will turn itself off. The timer will automatically turn the TV on (if it is off) at the time you schedule and select.

Set Time

Select the hour and minute, including AM or PM, when the TV is to turn on. Press ▲ or ▼ to slowly adjust the time. Press and hold ▲ or ▼ to quickly adjust the time.

Set Day

Select the day or days that the TV will turn on automatically. Press ADJUST ▲ or ▼ to select Everyday, Mon-Fri (Monday through Friday), or the individual days of the week.

Device

Press ADJUST ▲ or ▼ to select the device to use when the timer turns on the TV. If the TV is already on, the timer will turn the TV to this selected device.

Channel

When Ant-A, Ant-B, or Ant-DTV is the selected device, you may select any memorized channel. Press ADJUST ▲ or ▼ to select the channel the TV will tune to this channel in memory when the timer turns it on. This includes sub-channels for Ant-DTV.

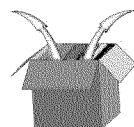

A/V Settings Menu: A/V Memory Reset, Video Mute, Black Enhancement, and Audio/Video Settings

A/V Memory Reset

A/V Memory Reset allows you to select the device which will have the A/V Settings returned to the original factory settings. To return a device's memory to the original factory settings, select the device and then press ENTER.

Audio/Video Settings

(Figure 1)

Each of the devices has its own A/V memory. Select device in A/V Memory Reset then select Audio or Video to adjust the device's individual settings. Press ENTER, and the menu is removed and the individual settings are displayed.

See pages 56 and 57 for an explanation of the possible A/V Settings.

Use ADJUST ▲ or ▼ to select the individual settings to be adjusted. Use ADJUST ◀ or ▶ to make the adjustment. For descriptions of the individual A/V settings see *A/V Setting Descriptions*, pages 56-57.

Using the AUDIO and VIDEO Buttons on the Remote Control

(Figure 2)

- 1** Press AUDIO or VIDEO to cycle through the available settings.
- 2** Press ◀ or ▶ to adjust the setting. After 5 seconds of inactivity, the setting display will disappear.

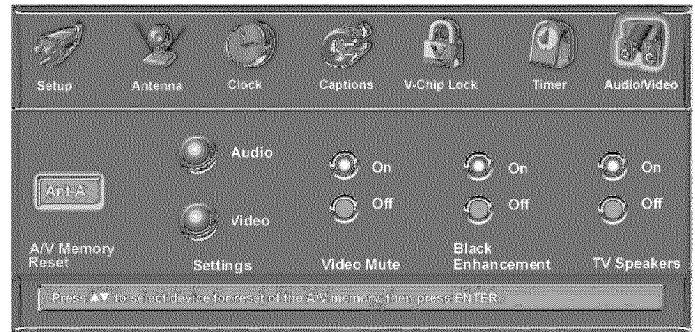

Figure 1. Audio/Video menu

Video Mute

(Figure 1)

Video Mute lets you display a blue background when no signal is being received on inputs 1-5.

Black Enhancement

(Figure 1)

The contrast in dark scenes is enhanced for better picture quality. Brighter scenes will not be affected.

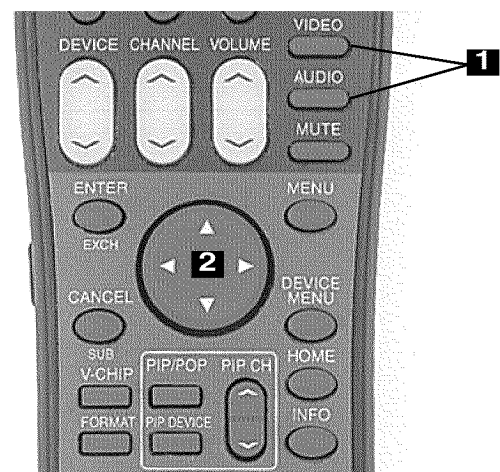

Figure 2. The AUDIO, VIDEO, and ADJUST buttons.

A/V Settings Menu: TV Speakers

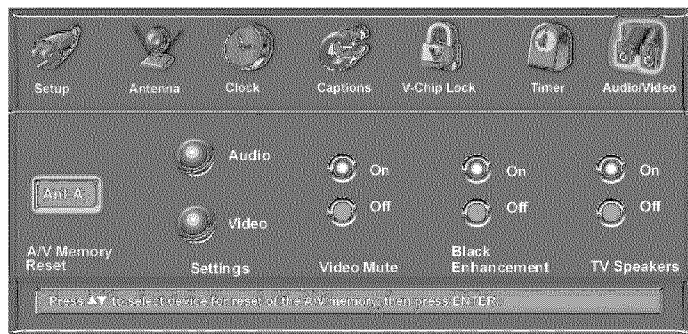
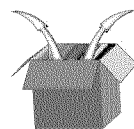

Figure 1. Audio/Video Settings menu

TV Speakers

(Figure 1)

This selection will turn on or off the TV's internal speakers. You may select Off when sending the sound through a separate stereo system or surround sound A/V receiver. You may also turn on or turn off TV speakers by selecting the A/V Receiver icon from the Device Selection Menu. See the NetCommand™ Guide for further instructions.

IMPORTANT

→ To prevent damage from a sudden increase in volume, make sure the TV volume is low before choosing ON.





A/V Setting Descriptions: Audio

Audio Settings

- 
- **Bass** enhances or reduces low frequency sound.
 - **Treble** enhances or reduces high frequency sound.
 - **Balance** adjusts the level of sound between the left and right speakers.
 - **Surround** creates simulated stereo and surround effects. Your choices are:
 - **Off:** No surround effects. Use this setting when using an A/V receiver with Dolby™ Pro Logic Surround, or Dolby™ Digital Surround.
 - **Surround Sound:** Your TV will create a simulated surround effect when watching a stereo program.
 - **Simulated Stereo:** Your TV will create a simulated stereo effect when watching a non-stereo program.
 - **Listen to** (for Ant-A and Ant-B) determines how your TV will receive a broadcast audio signal and play back the sound you hear. Your choices are:
 - **Stereo:** Default setting. The TV will play stereo broadcasts in stereo and mono broadcasts in mono. The word “Stereo” will be displayed when you tune to a channel broadcasting stereo.
 - **SAP (Second Audio Program):** Additional monaural soundtrack that you cannot hear during normal TV viewing. The SAP signal might be related to the program you are watching, such as a soundtrack in a foreign language, or unrelated to the program you are watching, such as a weather report. If a SAP signal is broadcast, the letters “SAP” will be displayed when you tune to the channel.
 - **Mono:** Reduces background noise, and should be used when receiving a weak stereo audio signal. All audio will be played mono with this setting.
 - **Listen to** (for Ant-DTV and IEEE 1394 devices) Determines what possible language you will hear. Your choices are:
 - **English**
 - **French**
 - **German**
 - **Italian**
 - **Portuguese**
 - **Spanish**
 - **Other**
 - **Listen to** (for devices connected to the TV INPUTS) is not available.
 - **Level Sound** (for Ant-A and Ant-B and analog devices) automatically equalizes the volume level of programs containing significant level differences from one segment to another (for example, regular programming to commercials). To receive the best quality through programs, you can turn this setting to Off.
 - **Level Sound** (for Ant-DTV and IEEE 1394 devices) automatically reduces loud passages and boosts soft passages to a more uniform loudness. When connecting to an A/V Receiver, set level sound to OFF and turn the speakers off to send full dynamics to the A/V Receiver.

A/V Setting Descriptions: Video

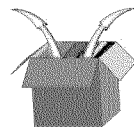

Video Settings

- ➔ **Contrast** provides a slider to adjust the white-to-black level. Low contrast shows a variety of shades in darker images, while high contrast shows darker images more uniformly black and makes colors appear more vibrant.
- ➔ **Brightness** provides a slider to adjust the overall brightness of the picture.
- ➔ **Sharpness** provides a slider to adjust the detail and clarity.
- ➔ **Color** provides a slider to adjust the color intensity.
- ➔ **Tint** provides a slider to adjust the proportion of red to green.
- ➔ **Color Temp** (Color Temperature) allows you to adjust how white images are displayed. Your choices are:
 - **Low 6500K** or **Low** (for DTV): White images will have a warm cast to them. This adjustment is an average and can vary due to ambient room lighting, video scene brightness and the TV's age. The Low 6500K represents the 6500K industry standard for NTSC (non-DTV) pictures.
 - **Medium**: White images will be balanced between the Low (warm) and High (cool) settings.
 - **High**: White images will have a cool cast to them. This setting may provide the most realistic picture under bright lighting.
- ➔ **Video Noise** use reduction to reduce minor noise (graininess) in the broadcast received on Ant-A and Ant-B. Use standard with good quality signals.
- ➔ **Image Type** maximizes the original camera media: Video or Film. Video media uses a video camera and is created at 30 frames per second. Film media uses a movie camera and is created at 24 frames per second. Examples of Video media are live TV broadcast such as news, special events, or video taped programs. Examples of Film media are motion pictures, made-for-TV movies, and many prime time programs. Filmed media is converted by the broadcaster or home video company to 30 frames per second to match TV or video standards. This conversion can leave subtle "picture artifacts" or conversion errors. Setting the Image Type to Film can reduce the picture artifacts and improve the picture quality, when viewing a movie from a 480i device such as a VCR, standard DVD or antenna.



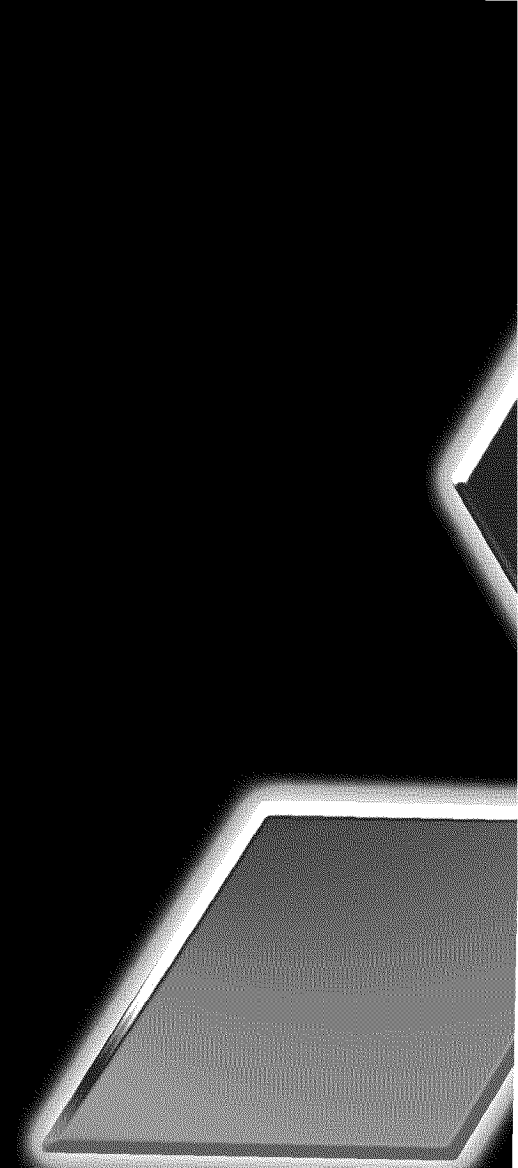

Part IV

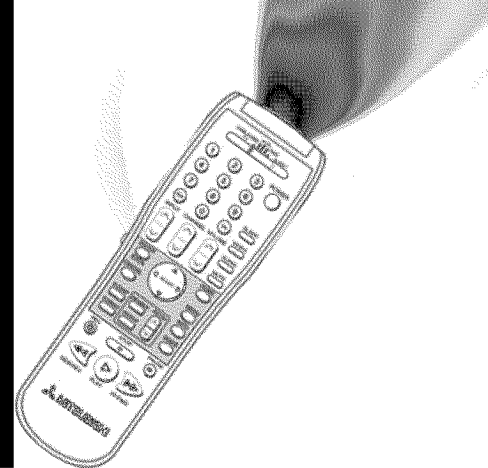

Operation

Remote Control Functions.....	60-69
Overview	60
Care and Operation	61
Channel Selection.....	62
Sleep Timer	62
Operation of PIP and POP.....	62
Display Formats.....	64-65
Programming the Remote Control to Control NetCommand™	
A/V Products	66
Programming the Remote Control to Control Non-NetCommand™	
A/V Products	67-68
Special Functions	69
IMPORTANT NOTES	70

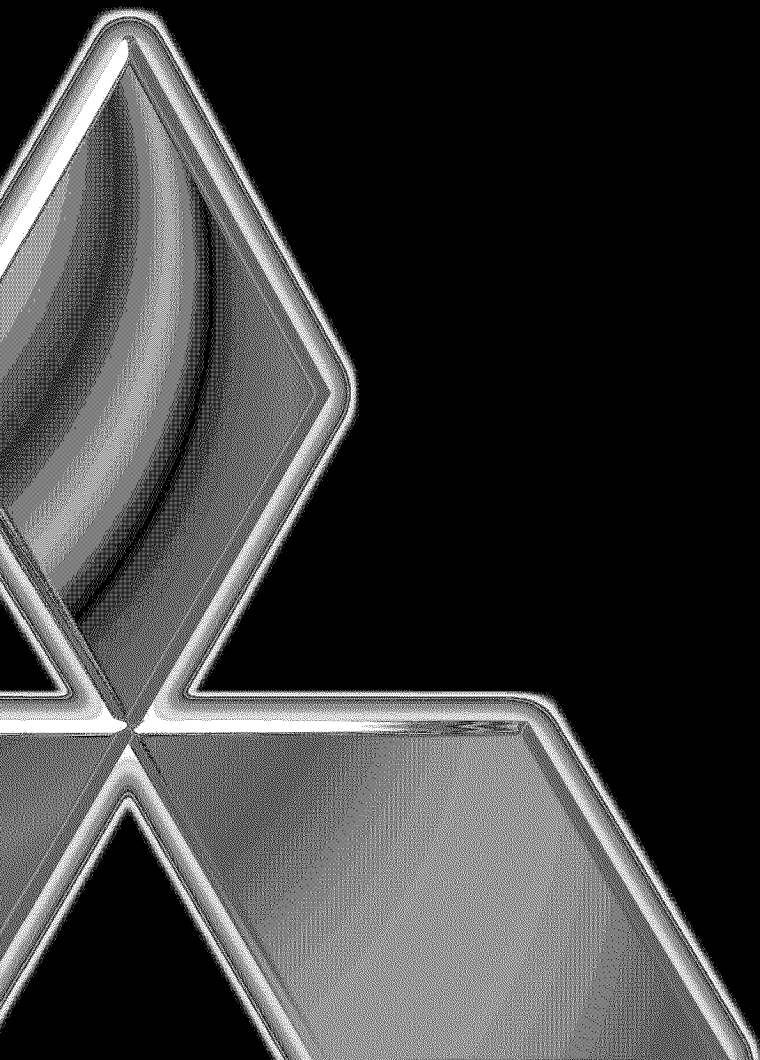

Remote Control Functions: Overview

Overview

(Following page, *gr e 1*)

- 1 Slide Switch:** Select A/V product to be controlled by the remote control.
- 2 Numbers:** Individually select channels or enter information into TV menus.
- 3 POWER:** Turns power on and off for TV and other A/V products.
- 4 SQV (Super Quick View™):** Scan through a memorized list of favorite channels.
- 5 QV (Quick View™):** Switch to last channel viewed.
- 6 GUIDE:** Display program guide for satellite receiver, some cable boxes, or DVD Disc Menu. Display Digital Channel Guide for Ant-DTV and other digital devices. Display Track List for AV Disc.
- 7 SLEEP:** Set the TV to turn off within 2 hours. See *Sleep Timer*, page 62, for setup instructions.
- 8 VIDEO:** Select the video settings.
- 9 AUDIO:** Select the audio settings.
- 10 MUTE:** Turn sound on or off.
- 11 DEVICE:** Displays the Device Selection Menu to select the device to view (Ant-A, Ant-B, Ant-DTV, devices connected to the TV's inputs, or IEEE 1394 devices).
- 12 CHANNEL:** Scroll up or down through memorized channels.
- 13 VOLUME:** Change sound level. Volume on-screen displays are separate for analog devices and digital devices.
- 14 ENTER/EXCH:** Select a channel number or menu item. Exchange PIP or POP and main TV picture.
- 15 MENU:** Display **ViewPoint®** on-screen menu system.
- 16 ADJUST:** Navigate menus, change settings, and move the PIP on-screen location. Also operates many NetCommand™ functions. See the NetCommand™ Guide for details.
- 17 CANCEL/SUB:** Clear SQV and some menu entries. Add separator between major and minor Ant-DTV channels.
- 18 DEVICE MENU:** Display menus for devices connected to TV. See the NetCommand™ Guide for details.
- 19 HOME:** Exit on-screen menus and return to TV viewing.
- 20 INFO:** Display on-screen summary of the current device used and any broadcast information available (including current V-Chip information).
- 21 V-CHIP:** Turns On or Off the V-Chip Lock.
- 22 FORMAT:** Change the shape and size of the main TV picture.
- 23 PIP/POP:** Cycle through PIP and POP display choices.
- 24 PIP DEVICE:** Displays PIP Selection Menu to select the PIP or POP device source.
- 25 PIP CH:** Scroll up or down through memorized channels in PIP or POP.
- 26 REC/CONNECT:** Record with your VCR, setup recordings for VCR or 1394 devices, initiate 1394 peer-to-peer connections. See the NetCommand™ Guide for details.
- 27 STOP:** Stop your VCR, DVD, or AV Disc. See the NetCommand™ Guide for details.
- 28 PAUSE:** Pause your VCR, DVD, AV Disc, or freeze the PIP or POP image. See the NetCommand™ Guide for details.
- 29 REW/REV:** Rewind or reverse search with your VCR, reverse scan with your DVD or AV Disc. See the NetCommand™ Guide for details.
- 30 PLAY:** Play your VCR, DVD, or AV Disc. See the NetCommand™ Guide for details.
- 31 FF/FWD:** Fast forward or forward search with your VCR, fast play with your DVD. See the NetCommand™
- 32**

Remote Control Functions: Care and Operation



Figure 1. The remote control functions.

Operation

Installing the Batteries:

(Figure 2)

- 1 Remove the remote control's back cover by gently pressing the ribbed tab in the direction of the arrow and sliding off the cover.
- 2 Load the batteries, making sure the polarities (+) and (-) are correct.

For Best Results from the Remote Control:

- ➔ Be within 20 feet of the equipment.
- ➔ Do not press two or more buttons at the same time unless instructed to.
- ➔ Do not allow to get wet or become heated.
- ➔ Avoid dropping on hard surfaces.
- ➔ Do not use harsh chemicals to clean. Use only a soft, lightly moistened cloth.
- ➔ Do not mix new and old batteries.
- ➔ Do not heat, take apart, or throw batteries into re
- ➔ Use only AAA batteries.

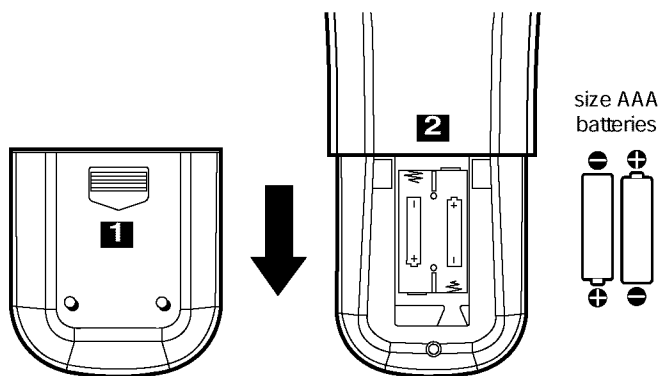

Figure 2. Installing the batteries.

Remote Control Functions: Channel Selection and Sleep Timer

Channel Selection

For Ant-A or Ant-B Channels:

- ➡ Enter three numbers (for channel 2, press 002).
- or
- ➡ Press the channel number and ENTER (for channel 2, press 2, then ENTER).
- or
- ➡ Enter the channel number and wait four seconds. The TV will change automatically.

For Ant-DTV Channels

(When Ant-DTV is the current device):

- 1 Enter two or three numbers for the major channel number. If three numbers are pressed, the separator is automatically added and you may proceed to step 2. If two numbers are pressed, you must add the separator by pressing the SUB button on the remote control.
- 2 Enter a 1-digit sub-channel number and wait four seconds. Enter a 1-digit sub-channel number and press ENTER. Or enter 2 digits and the TV will automatically switch channels.

Sleep Timer

Setting the Sleep Timer:

- ➡ Press SLEEP on the remote control.
- ➡ A message indicating the length of time the sleep timer is to be set for is displayed on the TV screen.
- ➡ Each press of SLEEP will increase the time displayed by 30 minutes, until the maximum value of 120 minutes is reached.
- ➡ After 5 seconds of inactivity, the message will disappear.
- ➡ Press SLEEP to view the remaining time before the timer turns the TV off.

Canceling the Sleep Timer:

- ➡ Press SLEEP to display the on-screen message.
- ➡ Press SLEEP repeatedly until OFF is displayed.
- ➡ After 5 seconds of inactivity, the message box will disappear.

Remote Control Functions: Operation of PIP and POP

Picture-In-Picture (PIP) and Picture-Outside-Picture (POP) features allow you to view Programming in different ways. While watching the main screen, you can display programs from other channels and other inputs. You can display a single PIP, side-by-side pictures, three POPs, or nine POPs.

Activating the PIP and POP

Figures 1-5 on following page

Press PIP/POP to activate the PIP/POP option. With each press of the PIP/POP button on the TV remote control (within 3

seconds of each other), the PIP/POP will cycle through the following display options.

- 1 POP: side-by-side pictures
- 2 POP: three POPs
- 3 POP: nine POPs
- 4 PIP: PIP
- 5 PIP/POP: off

To turn PIP/POP off, wait at least 10 seconds, and press PIP/POP. The next time you activate PIP/POP, the last used PIP/POP option will be displayed.

Remote Control Functions: Operation of PIP and POP

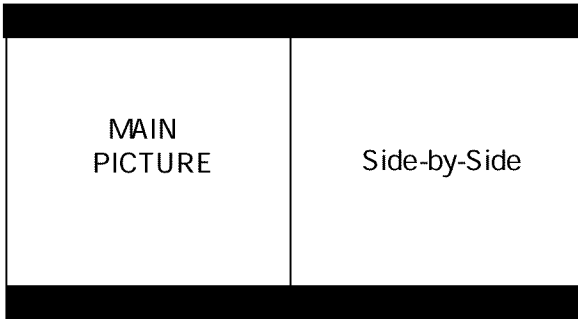

Changing PIP/POP Device

Press PIP DEVICE to change the PIP or POP picture source device. A menu similar to the Device Selection Menu will be displayed.

Changing PIP/Side-by-Side Channels

Press PIP CH to scroll up and down through memorized channels on Ant-A and Ant-B.

Exchanging Program Images

Press ENTER/EXCH to exchange the main picture and the PIP/POP picture.

Moving PIP Image

If no menus are on the screen, press ADJUST ▲, ▼, ◀, or ▶ to move the PIP display anywhere on the main screen.

Automatic POP Switching

When automatic POP switching is active, the TV will cycle through memorized channels or strobe pictures from other A/V components in the POP display.

Selecting POP "Live" Image

Press ADJUST ▲, ▼, ◀, or ▶ then press ENTER to select a different POP "live" image (automatic POP switching must be paused).

Freeze the PIP and Side-By-Side Picture, Pause POP Switching

Press PAUSE to freeze the PIP and side-by-side images or pause POP switching. Press PAUSE again to return to a "live" image or restart POP switching.

PIP/POP Audio Signal

For PIP/POP audio connection illustration, see *Back Panel Functions - 2*, page 13. Volume for the PIP AUDIO OUTPUT is controlled by the amplifier or wired headphones.

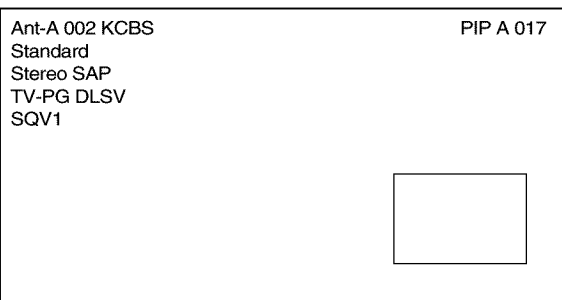
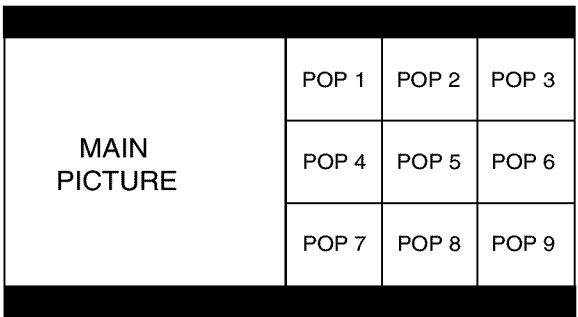
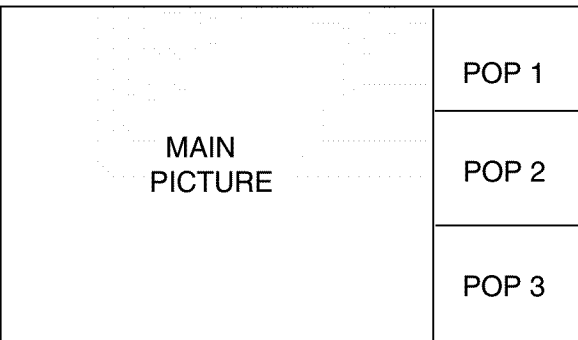

PIP/POP Combinations

Main Picture	PIP Picture	Ant-A	Ant-B	Inputs 1-5	Component 1 & 2 (480i only)**	Input-DTV (480i only)**	Ant-DTV	IEEE 1394	VGA
Ant-A	Yes*	No	Yes	Yes	Yes	No	No	No	
Ant-B	Yes	Yes*	Yes	Yes	Yes	No	No	No	
Inputs 1-5	Yes	Yes	Yes*	Yes	Yes	No	No	No	
Component 1 & 2 (480i only)**	Yes	Yes	Yes	Yes*	Yes	No	No	No	
Input-DTV (480i only)**	Yes	Yes	Yes	Yes	Yes*	No	No	No	
Ant-DTV	No	No	No	No	No	No	No	No	
IEEE 1394	No	No	No	No	No	No	No	No	
VGA	No	No	No	No	No	No	No	No	

*Same channel for Ant-A and Ant-B or same input for other inputs not available for side-by-side.

**480p and 1080i signals are not compatible with PIP/POP.

Non-Anamorphic Picture (4:3)

Anamorphic Widescreen Picture (16:9)

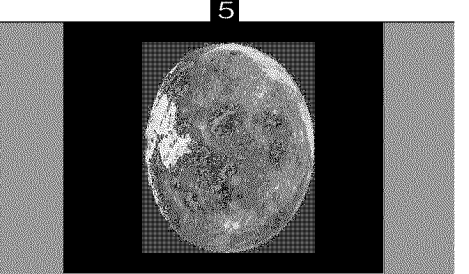
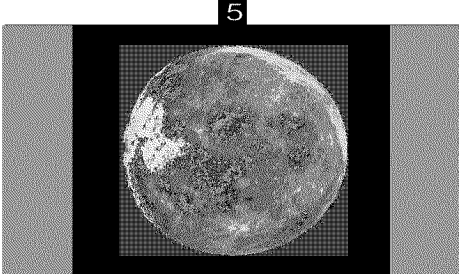
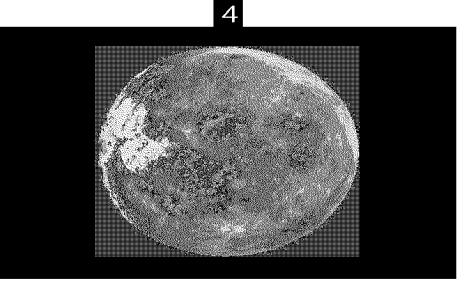
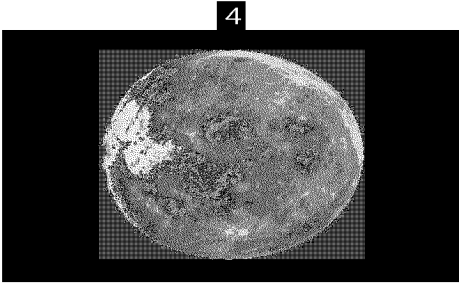
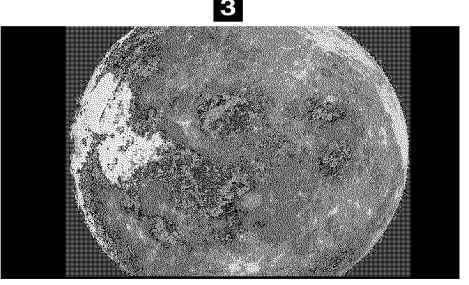
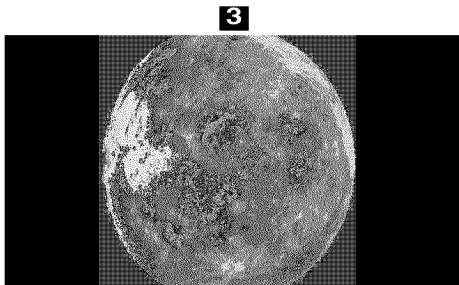
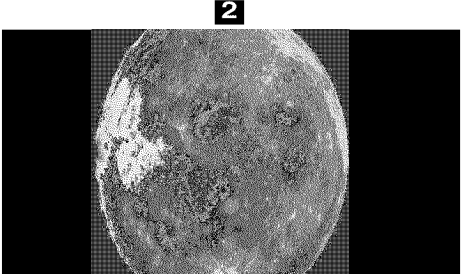
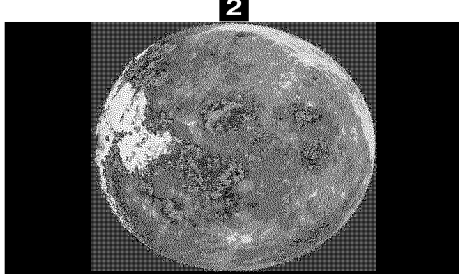
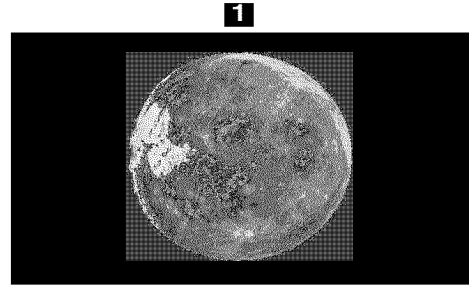
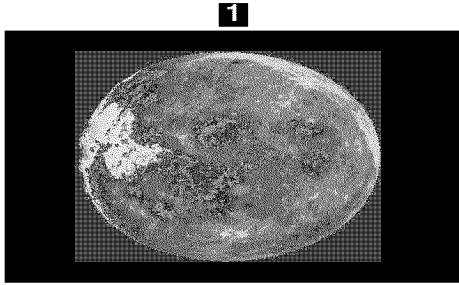

Input/ Signal	Format	Narrow (gray side bars)	Standard (full screen linear)	Expand (vertical expansion)	Zoom (2.35:1 horizontal & vertical expansion)	Stretched (full screen waterglass)
Ant-A		OK	OK	OK	OK	OK
Ant-B		OK	OK	OK	OK	OK
Ant-DTV(480i/480p 4:3)		OK	OK	OK	N/A	N/A
Ant-DTV(1080i/480p 16:9)		N/A	OK	N/A	N/A	N/A
Input-DTV(480i)		OK	OK	OK	OK	OK
Input-DTV(480ip)		OK	OK	N/A	N/A	N/A
Input-DTV(1080i)		N/A	OK	N/A	N/A	N/A
Inputs 1-5		OK	OK	OK	OK	OK
Component 1/2(480i)		OK	OK	OK	OK	OK
Component 1/2(480p)		OK	OK	N/A	N/A	N/A
VGA		N/A	OK	N/A	N/A	N/A
1394(480i/480p 4:3)		OK	OK	OK	N/A	N/A
1394(1080i/480p 16:9)		N/A	OK	N/A	N/A	N/A

Remote Control Functions: Display Formats



- 1 Standard:** This is the full screen format. HDTV signals will automatically use this format. This format is also useful to display Anamorphic DVDs that have 1.78:1 or 1.85:1 aspect ratios. Anamorphic DVDs that have the 2.35:1 aspect ratio will still display black bars at the top and bottom. Narrow (4:3) images will be stretched evenly from side to side.
- 2 Expand:** This will enlarge the picture, cropping off some of the image at the top and bottom. This is useful to reduce the letterbox top and bottom bars of non-anamorphic DVDs or to correct narrow (4:3) images that have been stretched in the Standard format.
- 3 Zoom:** This will enlarge the picture, cropping off some of the image at each side, and top and bottom. This is useful to remove or reduce the black top and bottom bars on anamorphic DVDs with a 2.35:1 aspect ratio.
- 4 Stretched:** This format will stretch a narrow (4:3) image across the screen, however, there is less stretch in the center than the sides. This will allow the entire narrow image to be displayed across the screen with less distortion than seen in the Standard format.
- 5 Narrow:** This format will display narrow (4:3) images in their original shape, and add stationary gray side bars to the screen.

This is a wide screen TV (also known as a 16:9 TV). This shape reflects the new types of images available from HDTV and many DVDs. There are still many older style narrow screen images (called 4:3 aspect ratio) you will encounter. While there will never be a perfect solution for displaying a narrow image on a wide screen, Mitsubishi offers several display formats to choose from.

Press FORMAT on the TV remote control to cycle through the available display formats.

IMPORTANT

→ Not all formats are available for all signals. See Table on Page 64 for combinations available.

Not all formats are available for PIP/POP. See the chart below.

PIP/POP Formats			
	Standard	Expand	Narrow
PIP	X	X	X
Side by Side	X	X	
POP	X		

IMPORTANT

→ Caution should be observed when using the Narrow format due to the stationary gray side bars. Please see page 70 for guidelines concerning stationary images.

Programming the Remote Control to Control NetCommand™ A/V Products

To Program the Remote to Control NetCommand A/V Products:

(See *NetCommand Supported Devices*, page 16, for the list of A/V products supported by the NetCommand System.)

- 1** Move the slide switch at the top of the remote to the TV layer.
- 2** Press and hold the POWER button on the remote control.
- 3** Enter the three digit code of 935, and then release the POWER button on the remote control.
- 4** The remote control is now programmed to send NetCommand™ signals to the TV so the TV can control the IEEE 1394 devices and selected older NetCommand™ supported IR devices. See the NetCommand™ guide for details.

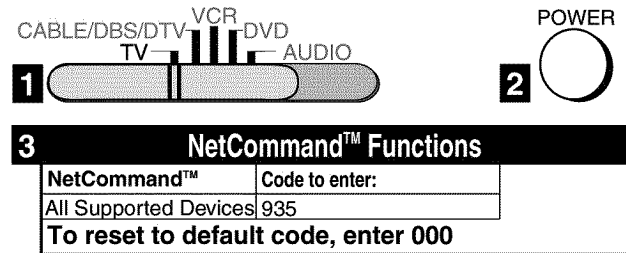

Figure 1. Programming the remote to control your NetCommand™ A/V devices.

Programming the Remote Control to Control Non-NetCommand™ A/V Products

To Program the Remote to Control Other Brands of Audio and Video Products:

(Figures 1-5)

- 1** Move the slide switch at the top of the remote to the product you want to control.
- 2** Press and hold the POWER button on the remote control.
- 3** Enter the ~~rest three digit code listed~~ for your equipment, and then release the POWER button on the remote control.
- 4** Point the remote control at the equipment and press the POWER button. If the equipment responds, the remote control is properly programmed to operate the equipment. If the equipment does not respond, repeat steps 2-4 with the next three digit code listed in step 3 for your equipment.

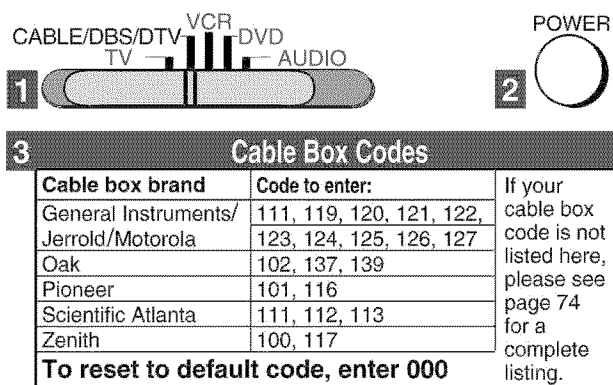

Figure 1. Programming the remote to control your cable box.

IMPORTANT

- If you cannot turn the cable box ON by pressing POWER, try pressing CHANNEL or the number buttons.

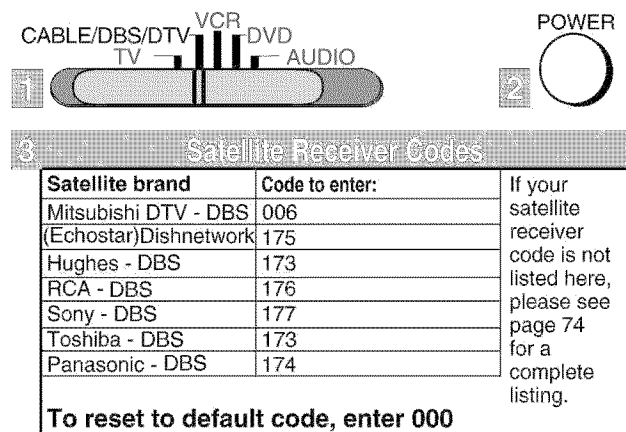

Figure 2. Programming the remote to control your satellite receiver.

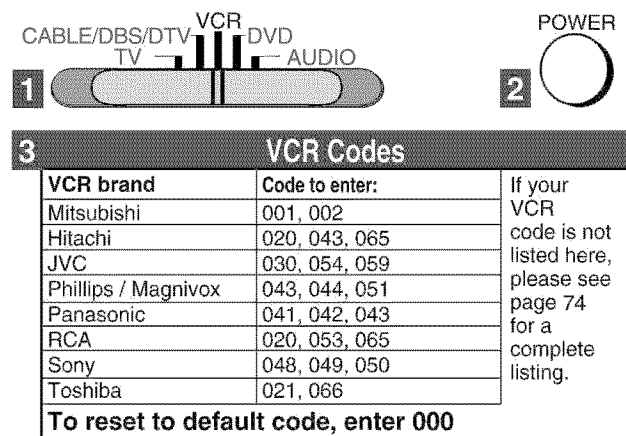

Figure 3. Programming the remote to control your VCR.

IMPORTANT

- When the switch is set to TV, the PLAY, STOP, REW/REV, and FF/FWD buttons will operate the VCR after the VCR codes have been properly programmed into the remote control.

Programming the Remote Control to Control Non-NetCommand™ A/V Products

DVD/LDP Player Codes		
DVD/LDP brand	Code to enter:	If your DVD code is not listed here, please see page 74 for a complete listing.
Mitsubishi (DVD)	003	
Mitsubishi (LDP)	016, 017	
Panasonic	250	
Pioneer DVD (LDP)	252 (016, 017)	
Sony	254	
Toshiba	253	
To reset to default code, enter 000		

Figure 4. Programming the remote to control your DVD/LDP.

A/V Receiver Codes		
Audio brand	Code to enter:	If your audio code is not listed here, please see page 74 for a complete listing.
Mitsubishi A/V receiver and/or CD player	010	
Denon	234, 235, 236	
Kenwood	200, 208	
JVC	232, 233	
Onkyo	209, 214	
Pioneer	205, 207	
Sony	222	
Yamaha	201, 202	
To reset to default code, enter 000		

Figure 5. Programming the remote to control your A/V receiver.

After entering the correct codes in each position of the remote control, use the slide switch to select which product will respond when an operational button is pressed. If the TV position has not been programmed to control NetCommand™ and you enter a code from the A/V Receiver chart while the slide switch is set to TV, the volume and mute functions change to match the A/V receiver. This is useful when using an A/V receiver with the TV all the time. In all other cases, only one of the below devices is allowed for each slide switch position.

TV position (when the remote has not been programmed to operate NetCommand™):

- ➡ TV
- ➡ A/V receiver (volume and mute only)

Cable/DBS/DTV position:

- ➡ Cable box
- ➡ Satellite receiver
- ➡ DTV receiver

VCR position:

- ➡ VCR
- ➡ DVD
- ➡ LD Player

DVD position:

- ➡ DVD
- ➡ Cable box
- ➡ LD Player
- ➡ VCR

Audio position:

- ➡ A/V receiver
- ➡ Cable box

Mitsubishi CD player [If you have a Mitsubishi A/V receiver, the audio position may be used in conjunction with selected Mitsubishi CD players. Your audio position must be programmed to 010].

IMPORTANT

➔ If the remote control has not been programmed to operate NetCommand™ and slide switch is set to TV when you enter an A/V receiver code, VOLUME and MUTE will control the A/V receiver rather than the TV. To return volume and mute control to the TV, set the slide switch to TV, press and hold POWER and enter 000.

IMPORTANT

➔ Some manufacturers may change their products, or they may use more than one remote control system. If this is the case, your remote control may not be able to operate your VCR, DVD, cable box, satellite receiver, or A/V receiver.



Remote Control Functions: Special Functions

When your remote control has been Programmed to operate another manufacturer's product, the function performed on each layer can vary. The most common functions are:

VCR				
•POWER	•PLAY	•PAUSE	•FF/FWD	
•CHANNEL up/down	•REC	•STOP	•REW/REV	
•Mitsubishi VCRs will be compatible with additional buttons				
Cable Boxes and Satellite Receivers				
•POWER	•ENTER (on some models)	•ADJUST up/down/left/right (on some models)		
•CHANNEL up/down	•CANCEL (on some models)	•GUIDE (on some models)		
•0-9 Number Buttons (on some models)				
A/V Receivers				
•POWER	•VOLUME	•MUTE		
Mitsubishi A/V Receivers				
•Direct Input Selection Buttons -use number buttons, SQV, and QV (on some models)				
Mitsubishi CD Players (not all functions for all models)				
•PLAY	•FF/FWD	•REW/REV	•PAUSE	•STOP
DVD and Laser Disc Players (not all functions for all models)				
•POWER	•PLAY	•ARROW up/down/left/right (on some models)	•PAUSE	•CANCEL (on some models)
•MENU	•STOP		•REW/REV	•ENTER
•0-9 Number Buttons (on some models)				
Mitsubishi Satellite Receiver				
•POWER	•GUIDE	•0-9 Number Buttons	•QV	•SQV (FAV)
•ENTER	•CHANNEL up/down		•INFO	•HOME (exit)
•ADJUST up/down/left/right			•SUB (-)	•MENU (ACTION)

IMPORTANT

→ The remote control may return to its initial setting when the batteries are changed. You may need to reprogram.



Warning: Do not leave stationary or letterbox images on-screen for extended periods of time. Mix the types of pictures shown. Uneven picture tube aging is NOT covered by your warranty.

The normal use of a TV should include a mixture of TV picture types. The most frequently used picture types should fill the screen with constantly moving images rather than stationary images or patterns. Displaying the same stationary patterns over extended periods of time, or displaying the same stationary pattern frequently can leave a subtle but permanent ghost image. To avoid this, mix your viewing pattern. Do not show the same stationary image for more than 15% of your total TV viewing in any one week. Display constantly moving and changing images that fill the screen whenever possible.

This projection TV uses picture tubes to project the image to the screen. **All picture tubes age with use.** As they age, their light output is gradually reduced. Normal TV pictures fill the screen with constantly changing images. Under these conditions, picture tubes age at an even rate across the entire screen. This maintains a TV picture that is evenly bright over the whole screen. Stationary images or images that only partially fill the screen (leaving black or colored bars to fill the screen), when used over extended periods of time or when viewed repeatedly, can cause uneven aging of the phosphors and leave subtle ghosts of the stationary images in the picture.

Still or stationary images may be received from broadcasters, cable channels, satellite channels, DVD discs, video tapes, laser discs, on-line services, web/internet searching devices, video games, and digital TV tuner/converter boxes. Examples of these types of images can be, but are not limited to the following:

- ➡ **Letterbox top/bottom black bars:** shown at the top and bottom of the TV screen when you watch a widescreen (16:9) movie on a standard (4:3) TV.
- ➡ **Side bar images:** solid bars shown on each side of an image when watching a standard (4:3) program on a widescreen (16:9) TV.
- ➡ **Stock-market report bars:** ticker running at the bottom of the TV screen.
- ➡ **Shopping channel logos & pricing displays:** bright graphics that are shown constantly or repeatedly in the same location.
- ➡ **Video game patterns and scoreboards**
- ➡ **Bright station logos:** moving or low-contrast graphics are less likely to cause uneven aging of the picture tubes.
- ➡ **On-line (internet) web sites:** or any other stationary or repetitive computer style images.



Lock Bypass Instructions Have Been Filed for Future Reference

Appendix A: Bypassing the V-Chip Lock

Appendix A: Bypassing the V-Chip Lock

Bypassing the V-Chip Lock

After you set the lock, you need your passcode to view a V-Chip locked program, view the locked TV, cancel the lock, or enter the V-Chip Lock menus.

If you forget your passcode, you can view the locked TV without entering your passcode. This is done by pressing the number 9 and QV buttons on the remote TV control at the same time, when your passcode is requested. This process temporarily unlocks the TV.

When entering the V-Chip Lock menu, this process deletes your old passcode and prompts you to enter a new passcode. Pressing HOME at this time will cancel the entire passcode.

Bypassing Front Button Lock

If you have misplaced the remote control, you can bypass the front button lock by pressing and holding the MENU button on the front panel for more than 8 seconds.

IMPORTANT

→ Cut along the dotted line and file bypass instructions in a safe place for future reference.

IMPORTANT

→ When changing or deleting your passcode, you must use the remote control included with this TV. You cannot use a Mitsubishi remote control from another component or a "universal" remote.

This page has been intentionally left blank



Component-1 and Component-2 Inputs

These inputs are compatible with component video signals from standard DVD players and other equipment sending a standard NTSC component video signal (480i).

These inputs may also be compatible with newer DVD players sending a progressive NTSC component video signal (480p).

VGA Input

This input will accommodate most computers capable of supporting a VGA monitor.

The only compatible display resolution is 640x480. The sync rate is 60 Hz. SVGA and XVGA resolutions are not supported.

INP-DTV

This input is compatible with most standard DTV and satellite receivers with component video (YPbPr) outputs. Compatible DTV signals are SDTV 480i/480p, and HDTV 1080i. All other DTV signals, such as 720p, need to be converted by the DTV receiver to one of the compatible signal types. Please check the DTV receiver specifications before connecting.

This input is compatible with some DTV receivers using RGB with sync on green or with "separate H and V sync". Compatible DTV signals are SDTV 480i, 480p, and HDTV 1080i. All other DTV signals, such as 720p, need to be converted by the DTV receiver to one of the compatible signal types. Industry standards for DTV RGB signals systems, synchronization, timing, and signal strengths are not currently established. These inputs will not be compatible with all DTV receivers that offer RGB. If your DTV receiver offers both DTV component video signals and DTV RGB signals, Mitsubishi suggests you use the DTV component video signals. Please check the DTV receiver specifications before connecting.

Input Levels and Timing with Component Video

- ➡ Y =1.0Vp-p (includes sync) 75-Ohms
- ➡ Pr =700mVp-p, 75-Ohms (can also receive signals from outputs labeled R-Y and Cr)
- ➡ Pb =700mVp-p, 75-Ohms (can also receive signals from outputs labeled B-Y and Cb)

Input Levels and Timing When Used With Component Video Signals

EIA - 770.3 Standard Levels and Timing

- ➡ Y =1.0Vp-p (includes sync) 75-Ohms
- ➡ Pr =700mVp-p, 75-Ohms
- ➡ Pb =700mVp-p, 75-Ohms
- ➡ H =Not Used
- ➡ V =Not Used

Input Levels and Timing When Used With RGB Video Signals

- ➡ G_(Y) =1.0Vp-p 75-Ohms
- ➡ R_(Pr) =700mVp-p, 75-Ohms
- ➡ B_(Pb) =700mVp-p, 75-Ohms
- ➡ H =4Vp-p+/-1.0v, 75-Ohms
(when using separate H and V sync)
- ➡ V =4Vp-p+/-1.0v, 75-Ohms
(when using separate H and V sync)

A/V Receivers

Mitsubishi	. 010, 011, 012, 013, 014, 015
Admiral	. 220
Aiwa	. 225, 226
Denon	. 234, 235, 236
Fisher	. 204
Gerrard	. 213
Harman Kardon	. 215
Jensen	. 223
JVC	. 232, 233
Kenwood	. 200, 208
Magnavox	. 227, 228
Marantz	. 224
McIntosh	. 216
Nakamichi	. 206, 217
Onkyo	. 209, 214, 240
Optimus	. 203, 227, 231, 230
Panasonic	. 219, 218, 221
Philips	. 223
Pioneer	. 205, 207
Quasar	. 219, 218, 221
RCA	. 203, 205, 227, 231, 230
Sansui	. 203, 211, 239
Sharp	. 234, 237
Sony	. 222
Sound-sigh	. 238
TEAC	. 212, 213, 210, 211
Technics	. 221, 218, 219
Victor	. 232, 233
Yamaha	. 201, 202

DVD Players

Mitsubishi	. 003
Denon	. 250
Ferguson	. 251
GE	. 251
JVC	. 257
Normande	. 251
Panasonic	. 250
Philips/Magnavox	. 258
Pioneer	. 252
RCA/Proscan	. 251, 256
Saba	. 251
Sony	. 254
Thompson	. 251
Toshiba	. 253
Yamaha	. 250
Zenith	. 259

Satellite Receivers

Mitsubishi	
HD/Satellite Receiver	006
EchoStar/Dishnetwork	175
GE	. 176
Hitachi	. 173, 181
Hughes	. 173
Panasonic	. 174
Philips	. 171, 172
RCA	. 176, 179, 180
Sony	. 177
Toshiba	. 170, 173
Uniden	. 171, 172

Cable Box

ABC	. 124
Archer	. 132, 125
Cableview	. 105, 132
Citizen	. 122, 105
Color Voice	. 128, 129, 130, 106, 107
Comtronics	. 128, 129, 130, 106, 107
Curtis	. 112, 113
Diamond	. 124, 132, 125
Eagle	. 129
Eastern	. 134
GC Brand	. 132, 105
GE	. 111, 112, 113
Gemini	. 122, 143
General Instruments / Jerrold / Motorola	. 111, 119, 120, 121, 122, 123, 124, 125, 126, 127
Hamlin	. 140, 141, 142, 145, 118, 112
Hitachi	. 103, 124
Macom	. 103, 104, 105, 108
Magnavox	. 128, 129, 130, 106, 107, 133, 138
Memorex	. 130
Movietime	. 132
Oak	. 139, 137, 102
Panasonic	. 109, 110, 114
Paragon	. 117
Philips	. 128, 129, 130, 106, 107, 133, 138
Pioneer	. 101, 116
Pulsar	. 105, 132
Puser	. 132
RCA	. 115
Realistic	. 132
Regal	. 112, 118, 140, 141, 142, 145
Regency	. 134
Rembrandt	. 137, 132, 105, 138
Samsung	. 105
Satellite	. 100
Scientific Atlanta	. 111, 112, 113
Signature	. 119, 124, 125, 126, 127, 120, 121, 122, 111
SL Mark	. 105, 101
Sprucer	. 105, 110
Starcom	. 119, 124, 125, 126, 127, 120, 121, 122, 111
Stargate	. 132, 105
Televue	. 101, 105
Texscan	. 144
Tocom	. 135, 136
Toshiba	. 104
Unika	. 132, 125
United Artists	. 139, 137, 102
United Cable	. 119, 124, 125, 126, 127, 120, 121, 122, 111
Universal	. 122, 132
Videoway	. 106
Viewstar	. 129, 130
Zenith	. 117, 100

VCRs

Mitsubishi	. 001, 002, 060, 067, 068, 061, 062
Admiral	. 055
Aiwa	. 047, 052
Akai	. 049, 034, 035, 036
Audio Dynamic	. 059, 031
Bell & Howell	. 025, 033
Broksonic	. 040, 046
Canon	. 043, 045
Citizen	. 026
Craig	. 025, 049, 026
Curtis Mathes	. 065, 044, 047
Daewoo	. 063, 021, 044, 079
DBX	. 059, 030, 031
Dimensia	. 065
Emerson	. 023, 038, 039, 040, 045, 046, 062, 063
Fisher	. 025, 028, 029, 027
Funai	. 047, 046, 040
GE	. 057, 065, 044
Go Video	. 057, 069, 070, 071
Goldstar	. 026
Hitachi	. 043, 065, 020
Instant Replay	. 044, 043
Jensen	. 059
JVC	. 059, 030, 031, 054, 076, 077
Kenwood	. 059, 030, 026, 031
LXI	. 047, 026, 020, 027, 028, 025, 029
Magnavox	. 051, 043, 044
Marantz	. 059, 030, 031
Marta	. 026
Memorex	. 044, 029
MGA	. 058, 060, 067, 068, 061, 062
Minolta	. 020, 065
Multitech	. 067, 047, 024
NEC	. 059, 030, 031, 054
Olympic	. 044, 043
Optimus	. 048, 041, 055, 026
Orion	. 046, 040
Panasonic	. 043, 044, 041, 042
Penney	. 044, 020, 065, 025, 059, 030, 031
Pentax	. 020, 031, 065
Philco	. 051, 044, 047, 043, 046, 040
Philips	. 051, 043, 044
Pioneer	. 043
Proscan	. 065, 020, 043, 044, 051, 021, 021
Quasar	. 041, 042, 043, 044
Radio Shack	. 053, 044, 025, 056, 029, 060, 047
RCA	. 053, 065, 020, 043, 044, 049, 051, 021, 022
Realistic	. 044, 025, 056, 029, 060, 047
Samsung	. 057, 022, 024, 053
Sansui	. 059, 046, 040, 072
Sanyo	. 025, 029
Scott	. 021, 022, 024, 029, 058, 060, 067, 068, 046, 040
Sears	. 025, 026, 027, 028, 020
Shantom	. 037
Sharp	. 055, 056
Signature 2000	. 047, 055
Singer	. 037
Sony	. 048, 049, 050, 073, 074, 075
SV2000	. 047
Sylvania	. 051, 043, 044, 047
Symphonic	. 047
Tashiro	. 026
Tatung	. 059, 030, 031
TEAC	. 059, 030, 047, 031
Technics	. 032, 041, 042, 043, 044
Teknika	. 044, 047
Toshiba	. 021
Totevision	. 026
Vector Research	. 031
Wards	. 055, 056, 029, 064, 026
Yamaha	. 025, 059, 030, 031
Zenith	. 064



Cleaning

Normally, light dusting with a dry, non-scratching duster will keep your TV clean. If cleaning beyond this is needed, please use the following guidelines:

First, turn off the TV and unplug the power cord from the power outlet.

Top and sides of the TV:

- Gently wipe down your TV with a soft, non-abrasive cloth such as cotton or a clean cloth diaper, lightly moistened with water. Dry with a second dry, soft, non-abrasive cloth.
- For oily dirt, add a few drops of mild liquid detergent, such as dishwashing detergent to the water used to moisten the cloth. Rinse with a second cloth moistened only with water. Dry with a third dry, soft, non-abrasive cloth.

Screen behind the Diamond Shield™:

- Follow the instructions for the top and sides, however, wipe gently in an up and down motion, following the grooves in the screen.
- Clean the entire screen evenly, not just sections of the screen.
- Do not allow liquid to drip down the grooves of the screen as some liquid may enter the TV between the screen and the screen frame.
- You may purchase Mitsubishi Screen Cleaner, part number CLEANING-VSS, by calling (800) 553-7278.

Anti-Glare Diamond Shield™:

(Diamond Series Models WS-55909, WS-65909 or WS-73909)

Anything abrasive can scratch the anti-glare coating of the Diamond Shield™ and household and window cleaners can remove the coating.

- Follow the instructions for cleaning top and sides, however, moisten the cloth with only water.
- Do not use any cleaning chemicals on the Diamond Shield™.
- DO NOT use Mitsubishi Screen Cleaner on the Anti-Glare Diamond Shield™

Cloth speaker grills:

- Lightly brush with a soft brush.
- If necessary, you can vacuum using the brush and hose attachments of your vacuum cleaner. Do not use the beater brush section on the grill cloth.

General Cleaning Warnings:

- DO NOT allow liquid to enter the TV through the ventilation slots or any crevice.
- DO NOT use any strong or abrasive cleaners as these can scratch the surfaces.
- DO NOT use any cleaners with ammonia, bleach, alcohol, benzene, or thinners as these can dull the surfaces.
- DO NOT spray liquids or cleaners directly on the TV's surfaces.
- DO NOT scrub or rub the TV harshly. Wipe it gently.

IMPORTANT

- ➔ DO NOT use any kind of abrasive, liquid, or spray cleaner on the surface of the TV screen or Diamond Shield™.

IMPORTANT

- ➔ For further assistance, please call
(800) 332-2119



Service

If you are unable to correct a problem with your TV, consult your Mitsubishi dealer or a Mitsubishi Authorized Warranty Service Center.

- ➔ DO NOT adjust any controls other than those described in this Owner's Guide.
- ➔ DO NOT remove the protective back cover of your TV.

Menus not described and shown in this owner's guide are designed for Factory use and for Authorized Service Personnel. Damage caused to the TV by non-authorized changes or changes made by non-authorized persons are not covered under warranty.

IMPORTANT

➔ For further assistance, please call
(800) 332-2119

Diamond Shield™ Installation for Models WS-55859 & WS-65869



The instructions below will lead you through the Diamond Shield installation process. Included in the Diamond Shield package are the following items:

For model WS-65869 only.

- ➡ (1) Diamond Shield™
- ➡ (2) molding clips

- 1** Carefully remove the Diamond Shield™ from its protective packaging. Wipe off any dust with a lint-free cloth.
- 2** Begin by inserting the shield, sliding it into the channels, starting at one side. Gently bow the Diamond Shield™ toward you and insert the side of the Diamond Shield™ into side channel then install the opposite side.
- 3** Install the top and bottom molding clips by pressing them into the opening, starting at a corner. Do not force the clip. The clip will slide into place. This completes the Diamond Shield™ installation.

To remove the Diamond Shield™, reverse the order of the above process.

- ➡ Diamond Shield™ for the model WS-55859 comes installed by the factory.

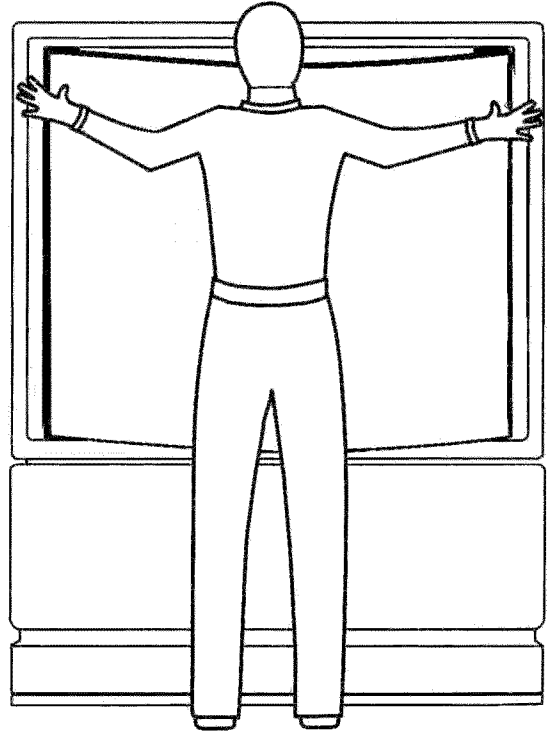



Diamond Shield™ Installation for Models WS-55909, WS-65909 and, WS-73909

The instructions below will lead you through the Diamond Shield installation process. Included in the Diamond Shield package are the following items:

For models WS-65909 and WS-73909 only.

- ➡ (1) Diamond Shield™
- ➡ (2) molding clips

1 Carefully remove the Diamond Shield™ from the protective packaging. Wipe off any dust with a lint-free cloth. Do not use any cleaners on the anti-glare Diamond Shield™.

2 Begin by inserting the shield, sliding it into the channels, starting at the bottom. Gently bow the Diamond Shield™ toward you and insert the top of the Diamond Shield™ into the top channel.

3 Install the left and right molding clips by pressing them into the opening, starting at a corner. Do not force the clip. The clip will slide into place. This completes the Diamond Shield™ installation.

To remove the Diamond Shield™, reverse the order of the above process.

➡ Diamond Shield™ for the model WS-55909 comes installed by the factory.

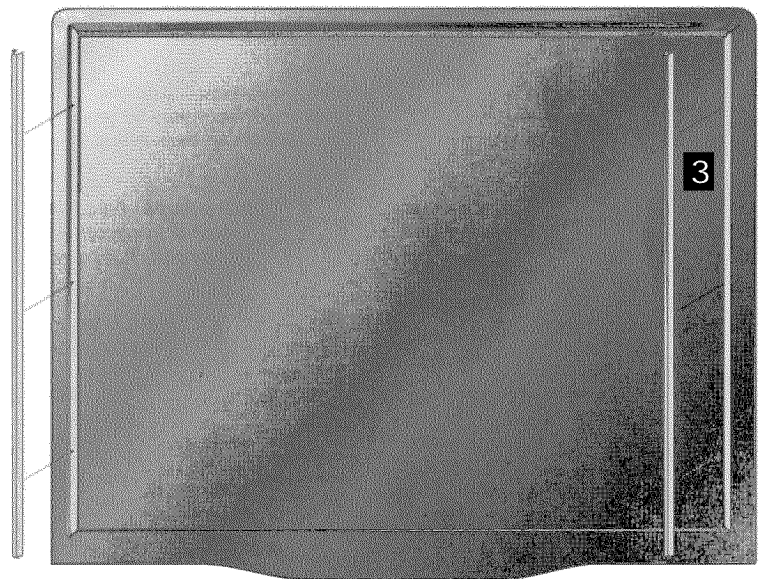
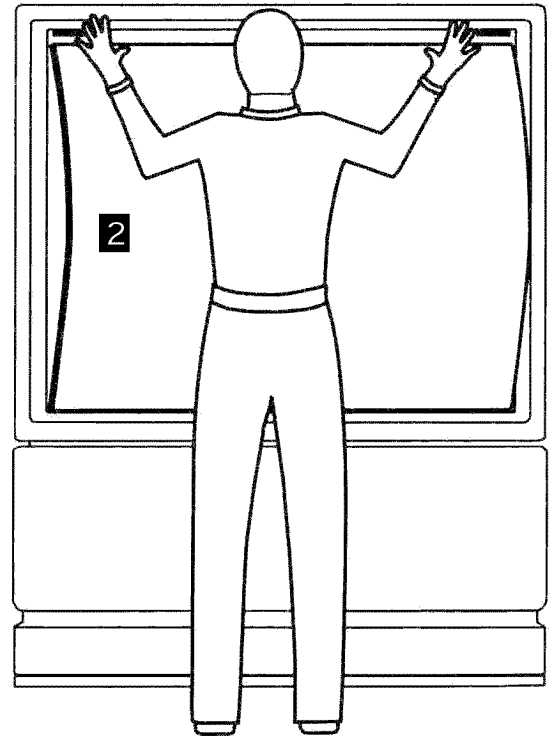

Cabinet Separation for Model WS-65869

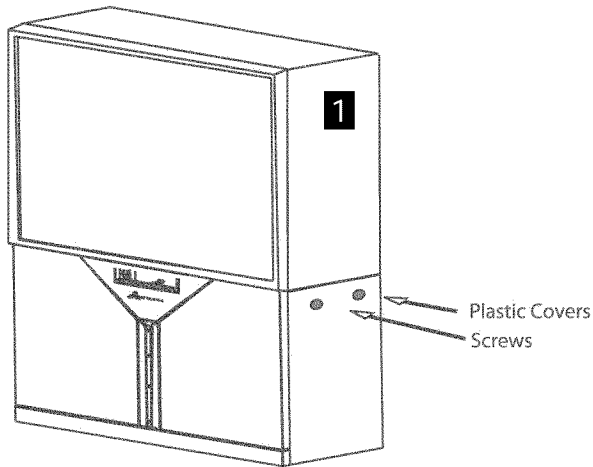

For Mitsubishi Dealers and Service Personnel Only

The Mitsubishi TV model WS-65869 cabinet has been assembled in two pieces. These pieces may be separated to allow for easier delivery and set up. The instructions below show how to safely separate and reattach the cabinet. This TV weighs over 320 lbs and has many sensitive components. This dismantling procedure should be done by authorized Mitsubishi Dealers or Service Personnel only.

The following steps should be performed by two people:

1 Remove the decorative Plastic Covers (2) on each side of the cabinet and then remove the exposed Screws (2) on each side.

2 Carefully lift the Cabinet-Top straight up until the Brackets are clear from the Cabinet-Bottom.

3 Carefully place the Cabinet-Top on the floor.

4 Once you have moved and positioned the Cabinet-Bottom to its desired location, reverse the procedure and mount the Cabinet-Top on the Cabinet-Bottom. Be sure you align the Brackets properly. Keep your feet clear of all joints! Replace the screws and the decorative Plastic Covers.

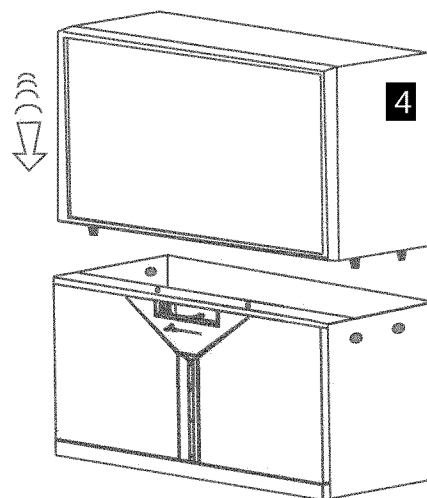
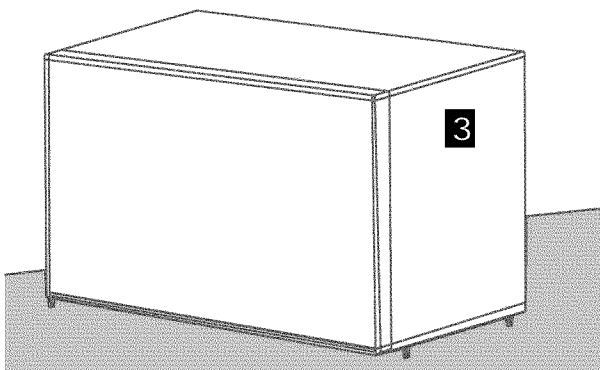
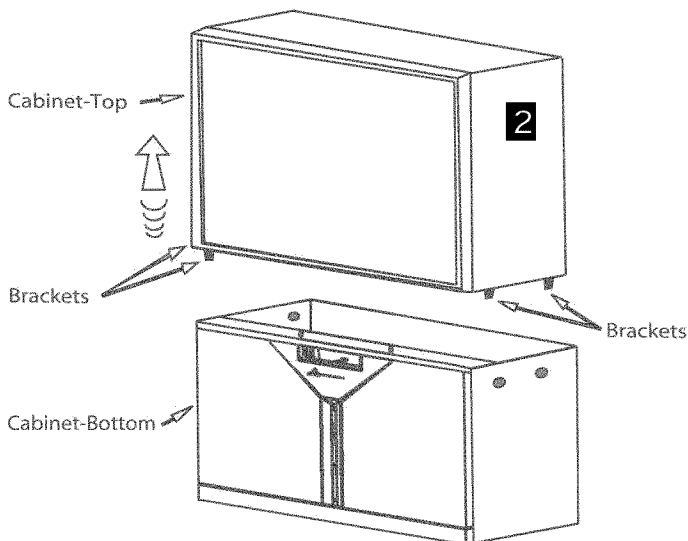

Cabinet Separation for Models WS-65909 and WS-73909

For Mitsubishi Dealers and Service Personnel Only

The Mitsubishi TV models WS-65909 and WS-73909 cabinet have been assembled in two pieces. These pieces may be separated to allow for easier delivery and set up. The instructions below show how to safely separate and reattach the cabinet. This TV weighs over 320 lbs and has many sensitive components. This dismantling procedure should be done by authorized Mitsubishi Dealers or Service Personnel only.

The following steps should be performed by two people:

- 1** Remove the decorative Plastic Covers (2) on each side of the cabinet and then remove the exposed Screws (2) on each side.
- 2** Carefully lift the Cabinet-Top straight up until the Brackets are clear from the Cabinet-Bottom.
- 3** Carefully place the Cabinet-Top on the floor.
- 4** Once you have moved and positioned the Cabinet-Bottom to its desired location, reverse the procedure and mount the Cabinet-Top on the Cabinet-Bottom. Be sure you align the Brackets properly. Keep proper clear of all joints! Replace the screws and the decorative Plastic Covers.

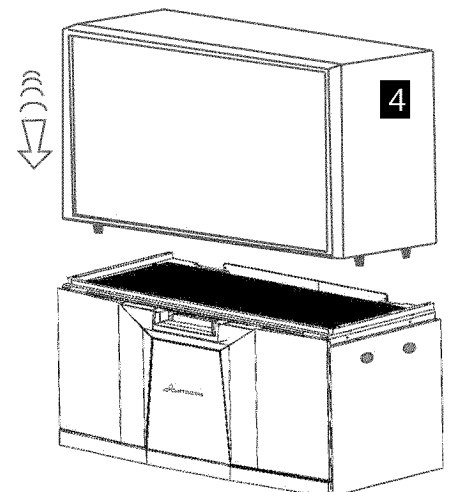
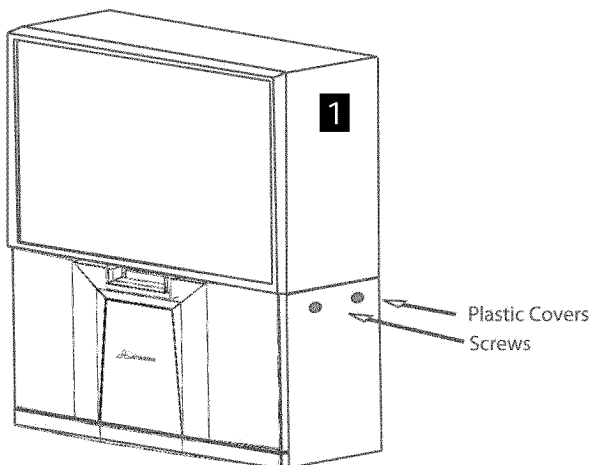
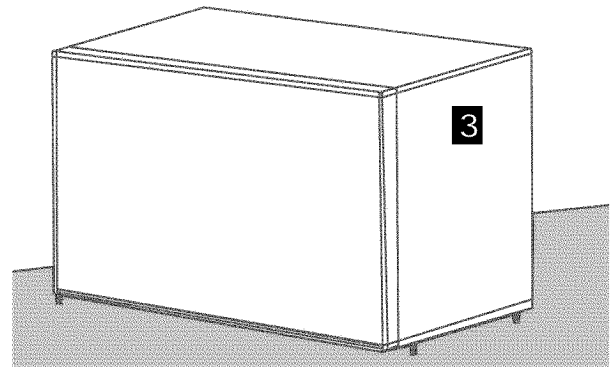
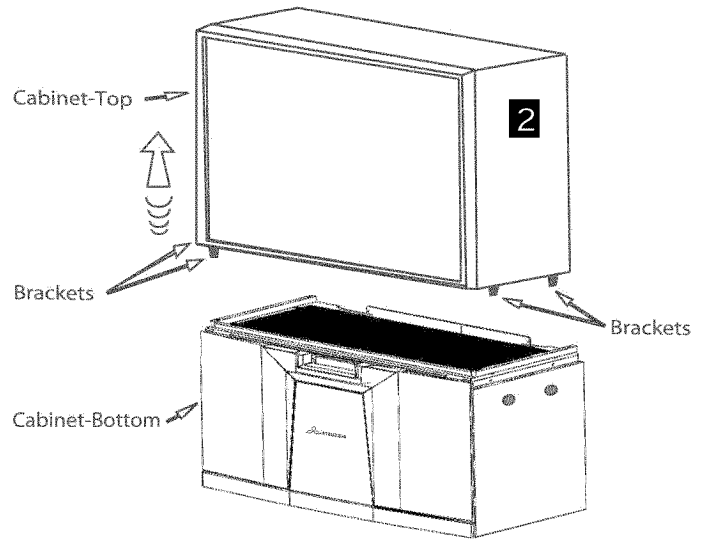

Problem	Possible Solution
<ul style="list-style-type: none"> The TV remote control does not work. 	<ul style="list-style-type: none"> Remote may be incorrectly set for NetCommand™. Check that the batteries are installed correctly. Check that the selected switch is set to "TV". Be no further than 20 feet from the TV when using the remote control.
<ul style="list-style-type: none"> The TV takes several seconds to respond to channel commands. 	<ul style="list-style-type: none"> It is normal for digital channels to take longer to tune in. Press ENTER after a channel number to avoid delays. Use the three digit number, i.e 002 for channel 2. Enter 5 digits for digital channels.
<ul style="list-style-type: none"> You cannot access a channel. 	<ul style="list-style-type: none"> Use number keys instead of CHANNEL up/down. Be sure the channel you want to view is in memory. Check that the TV is turned to the correct device or antenna for that channel, by pressing the DEVICE button. Make sure the V-Chip lock is off (page 50).
<ul style="list-style-type: none"> On-screen displays appear each time you change a function. 	<ul style="list-style-type: none"> This is part of normal TV operation.
<ul style="list-style-type: none"> You cannot program the TV to turn on automatically. 	<ul style="list-style-type: none"> The TV may be locked. The clock may not be set.
<ul style="list-style-type: none"> There is no sound even when the volume is turned up. 	<ul style="list-style-type: none"> Check audio source in Device Menu. Check to see if the MUTE button is on. The TV's "Listen to:" setting may be set to SAP. Check that "TV Speakers" setting is ON in the Audio/Video menu
<ul style="list-style-type: none"> You have forgotten your lock passcode. 	<ul style="list-style-type: none"> See <i>Appendix A, Bypassing the V-Chip Lock</i>, page 71.
<ul style="list-style-type: none"> PIP does not display a picture. 	<ul style="list-style-type: none"> Make sure the V-Chip lock is off (page 50). Not all inputs can be displayed as a PIP (page 63).
<ul style="list-style-type: none"> The sound does not match the screen picture. 	<ul style="list-style-type: none"> NetCommand setup incorrectly. The TV's "Listen to:" setting may be set to SAP. If using stereo or A/V receiver speakers, check input selection on the stereo or A/V receiver. If using stereo or A/V receiver, check that AUDIO of MONITOR OUTPUT on TV's back panel is connected to the A/V receiver.
<ul style="list-style-type: none"> There is a large black or gray rectangle on the screen. 	<ul style="list-style-type: none"> The TV closed captioning has been set to "text" mode, but there is no text information being broadcast. Turn Off in the CAPTIONS menu (page 49).
<ul style="list-style-type: none"> You cannot see a picture when you play a VCR tape. 	<ul style="list-style-type: none"> Display the Device Selection Menu and select the correct VCR. Check your VCRs owner's guide for further troubleshooting.
<ul style="list-style-type: none"> V-Chip is not working 	<ul style="list-style-type: none"> Make sure that V-Chip is On (page 50). If V-Chip Time is currently set to disable the V-Chip lock, the V-Chip will not block programing.

Problem	Possible Solution
<ul style="list-style-type: none"> The TV will not turn on after being plugged in. 	<ul style="list-style-type: none"> If green light on front panel is blinking, please wait for at about one minute for light to turn off, then try to power on again.
<ul style="list-style-type: none"> TV functions do not respond to the remote control or front panel control and the TV will not power off. 	<ul style="list-style-type: none"> Use the System Reset button as explained below.
<ul style="list-style-type: none"> When viewing a stopped VCR, while lines are rolling on the screen. 	<ul style="list-style-type: none"> Turn off video mute for the VCR. Begin playing the tape. Change the VCR input to the antenna input.
<p>Using The System Reset Button: If the TV doesn't respond to either the remote control or the front panel controls and will not power off, press the SYSTEM RESET button with a pointed item like the point of ball point pen.</p>	
<p>The TV will turn off and the TIMER light will flash quickly for about one minute. When the TIMER light stops flashing, you may turn the TV again. The changes you made while the TV was on before you used the SYSTEM RESET button may be cancelled, however, the changes you made previously are not cancelled. Only those changes since the last power on may be lost when the system reset button is pressed. All other settings are retained.</p>	

- A**
 accessories, 9
 adding and deleting devices, 32, 33
 adaptors (BNC to RCA), 22
 adjusting (convergence), 44-45
 adjusting audio/video, 54-57
 alignment (convergence), 44-45
 Antenna Menu, 46
 antennas (connecting), 17, 18
 Audio button, 39, 54, 60
 Audio settings, 56
 Audio/Video Menu, 54
 A/V Memory, 54
- B**
 back panel, 13-14
 Balance, 56
 Bass, 56
 Black Enhancement, 54
 blocking (enabling V-Chip), 50-51
 Brightness, 57
 bypassing (parental lock), 71
- C**
 cabinet separation, 79-80
 Channels (memorize), 46
 cleaning, 4, 75
 Clock (setting), 48
 Closed Captions, 49
 Color, 57
 Color Temp, 57
 connecting, 17-24
 analog antenna, 18
 analog VCR, 19
 cable box, 18
 computer, 24
 digital broadcasts, 17
 DVD player, 21
 external DTV receiver, 22-23
 IR-Home Theater Control, 24
 IR-Repeater, 24
 S-Video device, 21
 compatibility (signal), 73
 Contrast, 57
 Convergence, 44-45
- D**
 Day setting, 45, 48
 Daylight Savings Time (DST), 48
 Device Selection, 39
 Diamond Shield Instructions, 75, 77-78
 Display Formats, 64-65
 dusting, 75
- E**
 Edit Setup Menu, 43
 Español, 28, 45
- F**
 Formats (display), 64-65
 Front Button Lock, 52, 71
 front control panel, 12
- G**
 games, 25, 70
- H**
 HDTV, 9
- I**
 Icon Position Menu, 43
 image type, 57
 IMPORTANT NOTES, 25, 70
 Important Safeguards, 4-5
 Installation Con g u r a t i o n s, 15
- L**
 Language, 28, 45
 Lock by Time, 52
- M**
 maintenance, 2, 4, 5, 75
 Memorize channels, 46
 menu screens (overview), 41-42
- N**
 Name channels, 46
 NetCommand™
 Devices Supported, 16
 Programming Remote Control, 66
 Setup, 26-35
- P**
 passcode, 50, 71
 peer-to-peer connections (Remote Control), 60
 Picture-in-Picture (PIP)
 Device Selection, 40, 63
 Operation, 62-63
 Picture-outside-Picture (POP)
 Operation, 62-63
- Q**
 Quick View™ (QV), 60
- R**
 remote control
 buttons, 60-61
 care and operation, 61
 channel selection, 62
 display formats, 64-65
 functions, 60-69
 IEEE 1394 operation, *see*
 NetCommand™ Guide
 installing batteries, 61
 programming for
 NetCommand™, 66
 PIP and POP operation, 62-63
 programming codes, 66-68, 74
 replacement, 2, 6
 Settings
 Audio, 56
 Video, 57
 Sleep Timer, 62

S

safeguards, 4-5
 servicing, 2, 5, 76
 Sharpness, 57
 Sleep Timer, 62
 Spanish, 28, 45
 Special Features, 9
 Special Functions(Remote Control), 69
 SQV (Super Quick View™), 47
 STATIONARY PICTURE
 WARNING, 1, 21, 25, 70
 Shield, Diamond, 75, 77-78
 surface(cleaning), 75
 surges, 4
 Surround Sound, 56
 System Reset, 12, 82

T

Time (setting), 48
 Timer (setting), 53
 Tint, 57
 Treble, 56
 Transport Menu, 45
 Troubleshooting, 81-82
 TV Speakers, 39, 55

U

unpacking, 9

V

V-Chip Lock, 50-52
 bypassing, 71
 entry to, 50
 Lock by Time, 52
 passcode setting, 50
 ratings and categories, 51
 V-Chip Time, 50
 ventilation, 4
 VGA Input, 24, 25, 73
 Video button, 39, 54
 Video Mute, 54
 Video Noise, 57
 Video settings, 57
 Viewpoint Menu System, 38

W

Warranty, Mitsubishi Limited, 85

End User License Agreement. This End User License Agreement (“Agreement”) grants you the right to use the software contained in this produce (the “Software”) subject to the following restrictions: You may not: (i) copy the Software, except for archive purposes consistent with your standard archive procedures; (ii) transfer the Software to a third party apart from the entire product; (iii) modify, decompile, disassemble, reverse engineer or otherwise attempt to derive the source code of the Software; (iv) export the Software or underlying technology in contravention of applicable U.S. and foreign export laws and regulations; and (v) use the Software other than in connection with operation of the product.

LICENSOR’S SUPPLIERS DO NOT MAKE OR PASS ON TO END USER OR ANY OTHER THIRD PARTY, ANY EXPRESS, IMPLIED OR STATUTORY WARRANTY OR REPRESENTATION ON BEHALF OF SUCH SUPPLIERS, INCLUDING BUT NOT LIMITED TO THE IMPLIED WARRANTIES OF NON-INFRINGEMENT, TITLE, MERCHANTABILITY OR FITNESS FOR A PARTICULAR PURPOSE.

Manufactured under license from Dolby Laboratories. “Dolby” and the double-D symbol are trademarks of Dolby Laboratories.

Mitsubishi Projection TV Limited Warranty

MITSUBISHI DIGITAL ELECTRONICS AMERICA, INC. ("MDEA") warrants to the original purchaser of this television that if purchased from an authorized MITSUBISHI Audio/Video Dealer, should it prove defective by reason of improper workmanship and/or material:

- a. **Parts.** The lenticular (i.e. front picture) screen and/or the DiamondShield™ is warranted against defects in materials and workmanship for a period of 30 days. All other parts are warranted for a period of one year from the date of the original purchase at retail. We will repair or replace, at our option, any defective part without charge for the part. Parts used for replacement are warranted for the remainder of the original warranty period.
- b. **Labor.** For 30 days after the original purchase at retail, we will repair or replace, at our option, the lenticular screen if it proves defective. For all other parts, we will provide the labor for a warranty repair by an authorized MITSUBISHI service center without charge for one year from the original date or purchase at retail.
- c. **Notice.** To obtain warranty service, you must notify an authorized MITSUBISHI service center of any defect within the applicable warranty time period.

1. TO OBTAIN WARRANTY SERVICE:

- a. Contact your nearest authorized MITSUBISHI service center whose name and address can be obtained from your MITSUBISHI dealer or by writing or calling MDEA at the address and telephone number provided below.
- b. Warranty service will be provided in your home or, if required, at an authorized service shop, provided that your television is located within the geographic territory customarily covered by an authorized MITSUBISHI service center. If not, you must either deliver your television to an authorized service location at your own expense, or pay for any travel and/or transportation costs the service center may charge to and from your home. Actual service labor will be provided without charge.
- c. Proof of purchase date from an authorized MITSUBISHI dealer is required when requesting warranty service. Present your sales receipt or other document which establishes proof and date of purchase. **THE RETURN OF THE OWNER REGISTRATION CARD IS NOT A CONDITION OF WARRANTY COVERAGE.** However, please return the Owner Registration Card so that we can contact you should a question of safety arise which could affect you.

2. THIS WARRANTY DOES NOT COVER damage to Diamond Shield, Lenticular screen or Fresnel lens, screen frame, cosmetic damage or to any other product where such damage is caused by unauthorized modification, alteration, repair or service of the product by anyone other than an authorized MITSUBISHI service center; physical abuse to or misuse of the product (including any failure to carry out any maintenance as described in the Owner's Guide or any product damaged by excessive physical or electrical stress); any products that have had a serial number or any part thereof altered, defaced or removed; product use in any manner contrary to the Owner's Guide (including uneven picture tube aging and imprinted images on the viewing screen); freight damage; or any damage caused by acts of God or other factors beyond the reasonable control of MDEA, such as power surge damage caused by electrical system or lightning. This warranty also excludes service calls where no defect in the product covered under this warranty is found, service calls related to unsatisfactory audio or visual reception or signal unless caused a defect in the product that is covered under this warranty, all costs, expenses or any other damages arising from product installation, or set-ups, any adjustments of user controls (including convergence, contrast, brightness, color, tint, retuning, star press), other adjustment necessary to prepare the unit for display or use, connection with any external audio receiver, antenna, cable or satellite systems, or service of products purchased or serviced outside the U.S.A. Please consult the operating instructions contained in the Owner's Guide furnished with the product for information regarding user controls.

3. ANY EXPRESS WARRANTY NOT PROVIDED HEREIN, AND ANY REMEDY WHICH, BUT FOR THIS PROVISION, MIGHT ARISE BY IMPLICATION OR OPERATION OF LAW, IS HEREBY EXCLUDED AND DISCLAIMED. THE IMPLIED WARRANTIES OF MERCHANTABILITY AND FITNESS FOR ANY PARTICULAR PURPOSE ARE EXPRESSLY LIMITED TO A TERM OF ONE YEAR.

4. UNDER NO CIRCUMSTANCES SHALL MDEA BE LIABLE TO PURCHASER OR ANY OTHER PERSON FOR ANY INCIDENTAL, SPECIAL OR CONSEQUENTIAL DAMAGES, WHETHER ARISING OUT OF BREACH OF WARRANTY, BREACH OF CONTRACT, OR OTHERWISE.

5. Some states do not allow limitations on how long an implied warranty lasts, or the exclusion or limitation of incidental, special or consequential damages, so the above limitations or exclusions may not apply to you.

6. This warranty gives you specific legal rights and you may also have other rights which vary from state to state.

7. BEFORE REQUESTING SERVICE, please review the instruction booklet to insure proper installation and correct customer control adjustment. If the problem persists, contact your nearest MITSUBISHI Dealer for the name(s) of authorized MITSUBISHI Service Center(s). If you are unable to obtain this information, please call 800-332-2119, or write us at the address below.

MITSUBISHI DIGITAL ELECTRONICS AMERICA, INC.
 9351 Jeronimo Road
 Irvine, CA 92618-1904



RETAIN THIS PORTION FOR YOUR RECORDS	SERIAL NO. _____
	MODEL NO. _____

DEALER NAME _____		
STREET ADDRESS _____		
CITY _____	STATE _____	ZIP _____
PHONE () _____	PURCHASE DATE _____	

Mitsubishi Projection TV Limited Warranty

mitsubishi

BIG SCREEN COMPANY™

ital

If you have questions regarding your television, call Consumer Relations at (800) 332-2119, or email us at MDEAService@bigscreen.me.com

To order replacement or additional remote controls or owner's guides call (800) 553-7278

or