

# Lifestyler®

Patent Pending

Model No. 831.285250

Serial No. \_\_\_\_\_

Write the serial number in the space above for future reference.

Serial  
Number  
Decal

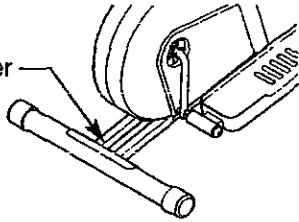

EXERCISE  
EQUIPMENT

QUESTIONS

HELPLINE!

1-800-736-6879

## ⚠ CAUTION

Read all precautions and instructions in this manual before using this equipment. Keep this manual for future reference.

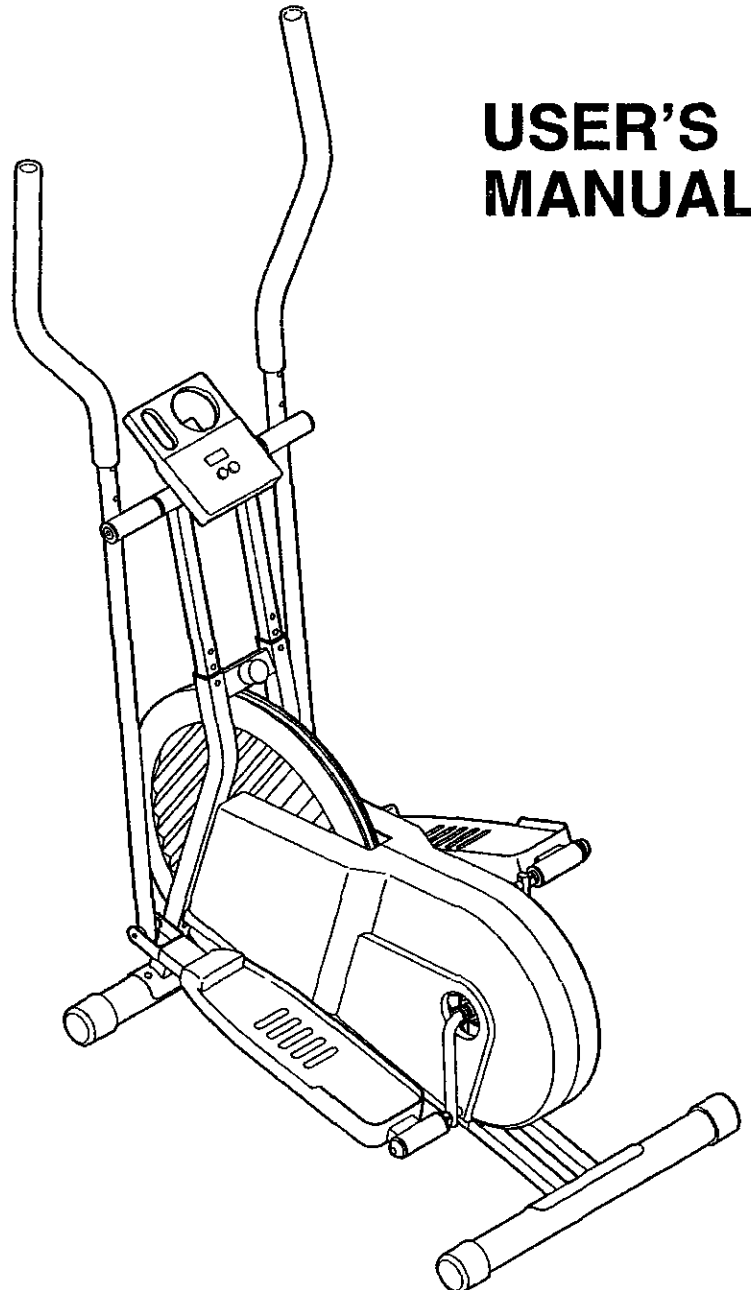

## USER'S MANUAL

SEARS, ROEBUCK AND CO., HOFFMAN ESTATES, IL 60179

# ***Lifestyler***<sup>®</sup>

## **ET 30**

---

### **TABLE OF CONTENTS**

IMPORTANT PRECAUTIONS .....	3
BEFORE YOU BEGIN .....	4
PART IDENTIFICATION CHART .....	5
ASSEMBLY .....	6
HOW TO USE THE ELLIPTICAL GLIDER .....	9
MAINTENANCE .....	11
CONDITIONING GUIDELINES .....	12
PART LIST .....	14
EXPLODED DRAWING .....	15
HOW TO ORDER REPLACEMENT PARTS .....	Back Cover
FULL 90 DAY WARRANTY .....	Back Cover

---

## IMPORTANT PRECAUTIONS

**⚠ WARNING:** To reduce the risk of serious injury, read the following important precautions before using the LIFESTYLER® ET 30 elliptical glider.

1. Read all instructions in this manual before using the elliptical glider.
2. Use the elliptical glider only as described in this manual.
3. It is the responsibility of the owner to ensure that all users of the elliptical glider are adequately informed of all precautions.
4. Place the elliptical glider on a level surface, with a mat beneath it to protect the floor or carpet. Keep the elliptical glider indoors, away from moisture and dust.
5. Inspect and tighten all parts regularly. Replace any worn parts immediately.
6. Keep children under the age of 12 and pets away from the elliptical glider at all times.
7. The elliptical glider should not be used by persons weighing more than 250 pounds.
8. Wear appropriate clothing when using the elliptical glider. Always wear athletic shoes for foot protection.
9. When mounting and dismounting the elliptical glider, always hold the handlebars and step onto and off the pedal that is in the lowest position.
10. Each time you stop exercising on the elliptical glider, allow the pedals to come to a complete stop before dismounting.
11. Always keep your back straight when using the elliptical glider. Do not arch your back.
12. If you feel pain or dizziness at any time while exercising, stop immediately and begin cooling down.
13. The elliptical glider is intended for in-home use only. Do not use the elliptical glider in a commercial, rental, or institutional setting.

**⚠ WARNING:** Before beginning this or any exercise program, consult your physician. This is especially important for persons over the age of 35 or persons with pre-existing health problems. Read all instructions before using. SEARS assumes no responsibility for personal injury or property damage sustained by or through the use of this product.

# BEFORE YOU BEGIN

Congratulations for selecting the LIFESTYLER® ET 30 elliptical glider. The ET 30 is an incredibly smooth exerciser that moves your feet in a natural elliptical path, minimizing the impact on your knees and ankles. And the unique ET 30 features adjustable resistance, upper-body handlebars, and a multi-mode exercise monitor to help you get the most from your exercise. Welcome to a whole new world of natural, elliptical-motion exercise.

**For your benefit, read this manual carefully before you use the elliptical glider.** If you have additional

questions, please call our toll-free HELPLINE at 1-800-736-6879, Monday through Saturday, 7 a.m. until 7 p.m. Central Time (excluding holidays). To help us assist you, please note the product model number and serial number before calling. The model number is 831.285250. The serial number can be found on a decal attached to the elliptical glider (see the front cover of this manual for the location of the decal).



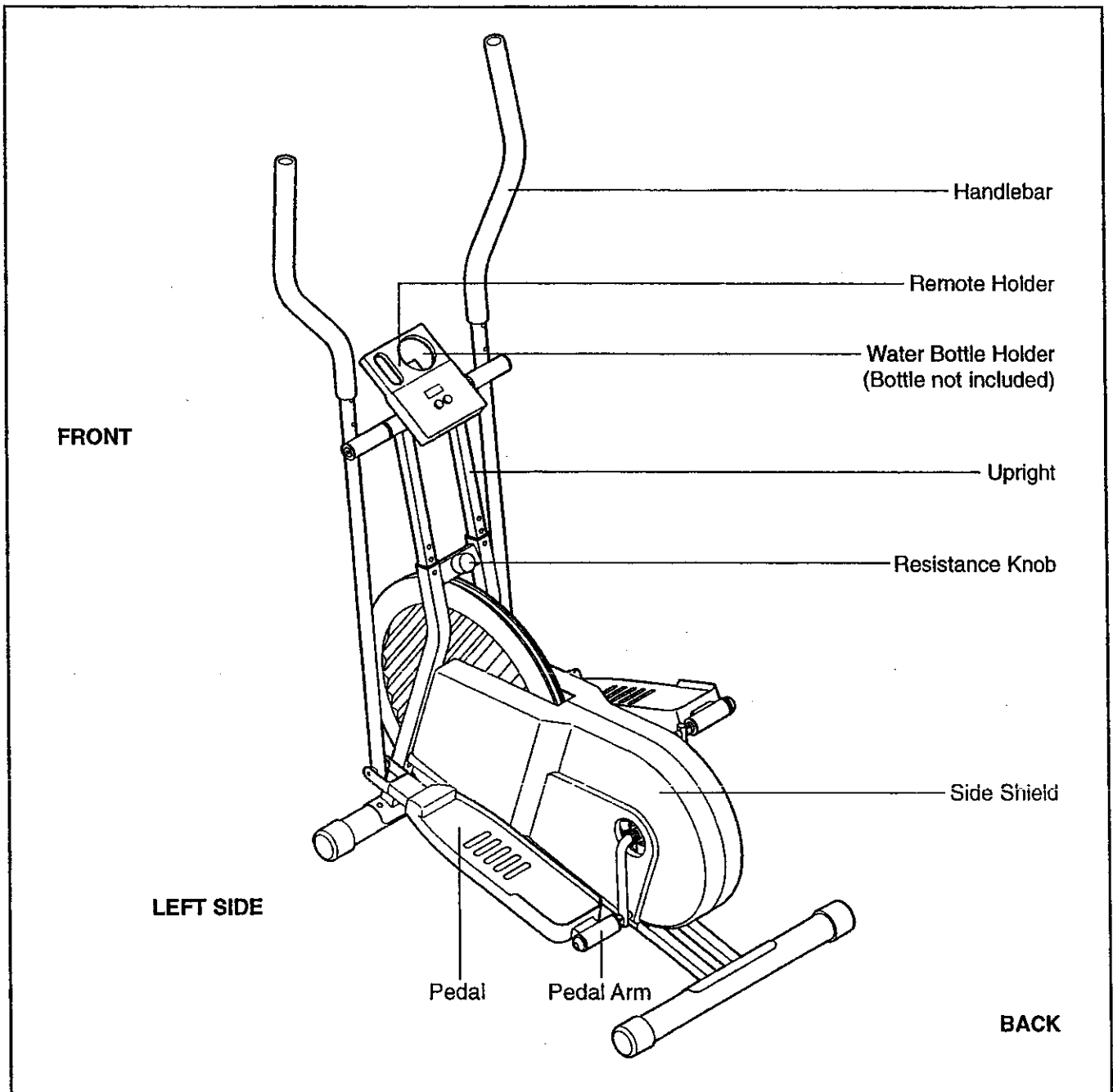

Before reading further, please look at the drawing below and familiarize yourself with the parts that are labeled.

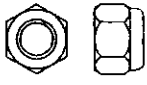
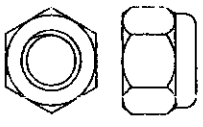
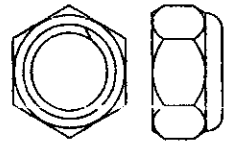

# PART IDENTIFICATION CHART

Use the chart below to identify the small parts used in assembly. The number in parenthesis below each part refers to the key number of the part, from the PART LIST on page 14. The number after the dash indicates

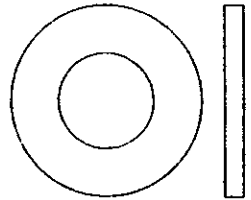

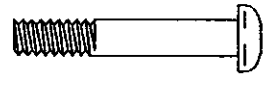
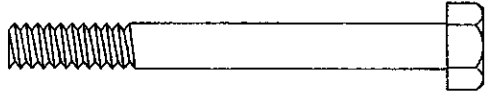
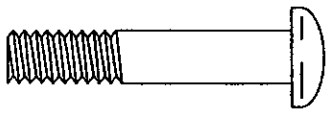
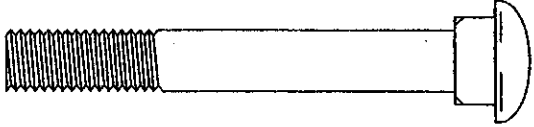
the quantity needed for assembly. **Note: Some parts may have been pre-attached for shipping. If a part is not in the parts bag, check to see if it has been pre-attached.**

		
M5 Nylon Locknut (52)-4	M8 Nylon Locknut (50)-8	1/2" Nylon Locknut (35)-2
		
M4 x 19mm Flange Screw (55)-6	Pivot Washer (54)-2	Pedal Washer (32)-2
		
M4 x 12mm Button Screw (57)-4	M8 x 19mm Button Screw (10)-2	M5 x 30mm Button Bolt (51)-4
		
M8 x 60mm Bolt (56)-2	M8 x 38mm Button Bolt (53)-2	
		
M8 x 63mm Carriage Bolt (49)-4		

**Note: Extra parts may be included.**

# ASSEMBLY

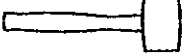
**Assembly requires two people.** Place all parts of the elliptical glider in a cleared area and remove the packing materials. Do not dispose of the packing materials until assembly is completed.

Assembly requires that you have two adjustable wrenches , a rubber mallet , and the included allen wrench .

1. Identify the Front Stabilizer (18), which is the narrowest Stabilizer. If there are no Stabilizer Endcaps (20) on the Front Stabilizer, push one onto each end.

Attach the Front Stabilizer (18) to the front of the Frame (1) with two M8 x 63mm Carriage Bolts (49) and two M8 Nylon Locknuts (50).

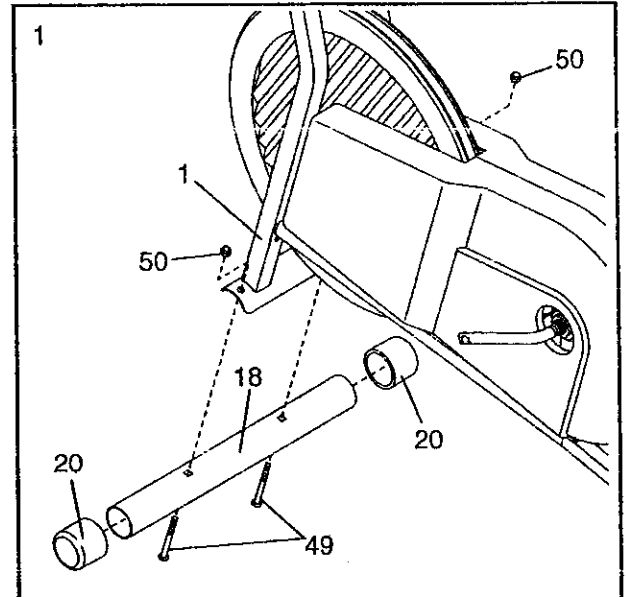

2. If there are no Stabilizer Endcaps (20) on the Rear Stabilizer (19), push one onto each end.

Attach the Rear Stabilizer (19) to the Frame (1) with two M8 x 63mm Carriage Bolts (49) and two M8 Nylon Locknuts (50).

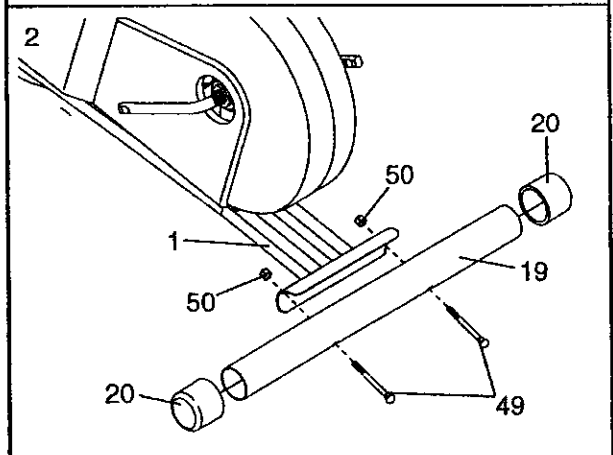

3. While a second person holds the Upright (2) near the Frame (1), connect the Extension Wire (47) to the Reed Switch Wire (41).

Insert the Upright (2) into the Frame (1), being careful to avoid damaging the wires. Make sure that the Frame Bushings (3) are inserted fully into the Frame. Adjust the Upright (2) so that a bolt can be inserted through the center hole in each side. Secure the Upright with two M8 x 38mm Button Bolts (53) and two M8 Nylon Locknuts (50).

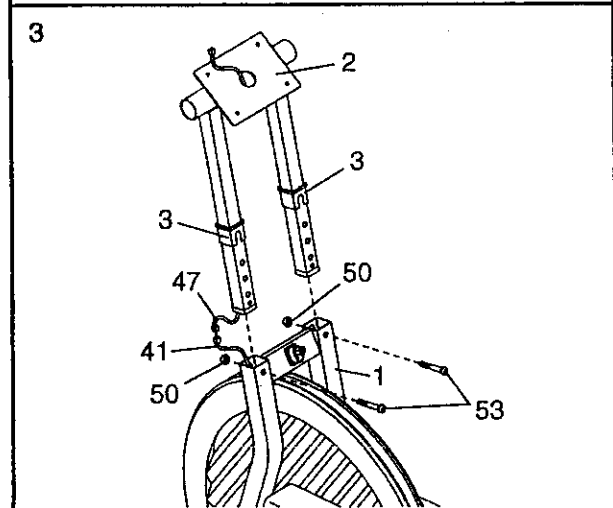

4. Make sure that the two Upright Bushings (8) are inserted into the Upright (2). Apply a thin film of the included grease along the length of the Pivot Axle (11). Insert the Pivot Axle into the Upright Bushings and the Upright.

Identify the Right Pivot Arm (7), which is marked with a sticker that has an "R" on it. Make sure that there are two Pivot Bushings (9) in the Right Pivot Arm. Slide the Right Pivot Arm onto the Pivot Axle (11), making sure that it is oriented as shown. Put a Pivot Washer (54) onto an M8 x 19mm Button Screw (10) and tighten the Button Screw into the Pivot Axle.

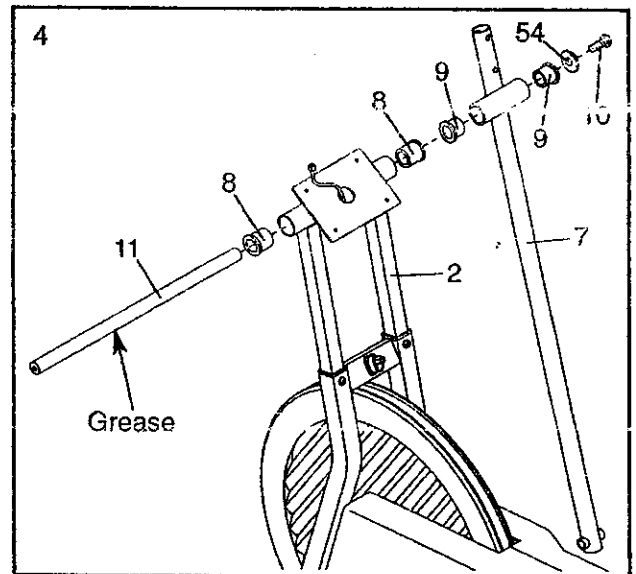

5. Identify the Left Pivot Arm (6), which is marked with a sticker that has an "L" on it. Make sure that there are two Pivot Bushings (9) in the Left Pivot Arm. Slide the Left Pivot Arm onto the Pivot Axle (11), making sure that it is oriented as shown. Put a Pivot Washer (54) onto an M8 x 19mm Button Screw (10) and tighten the Button Screw into the Pivot Axle.

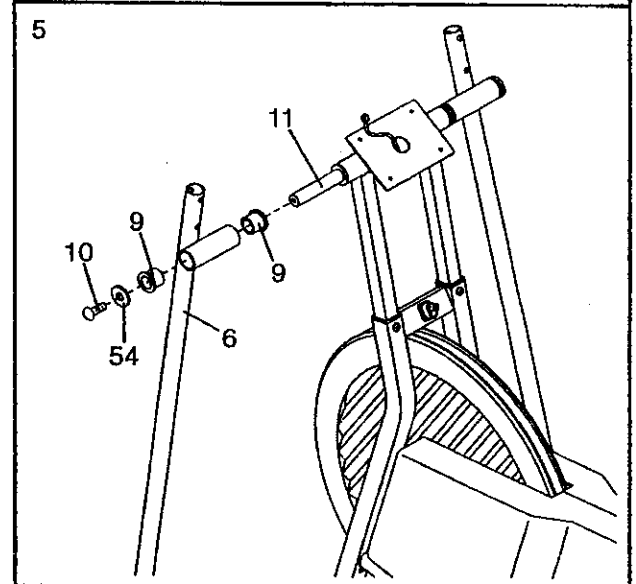

6. Insert a Handlebar (12) into the Right Pivot Arm (7). Slide the Foam Grip (13) up to expose the mounting holes. Secure the Handlebar with two M5 x 30mm Button Bolts (51) and two M5 Nylon Locknuts (52). Slide the Foam Grip down over the Button Bolts and Nylon Locknuts.

Attach the other Handlebar (12) to the Left Pivot Arm (6) in the same manner.

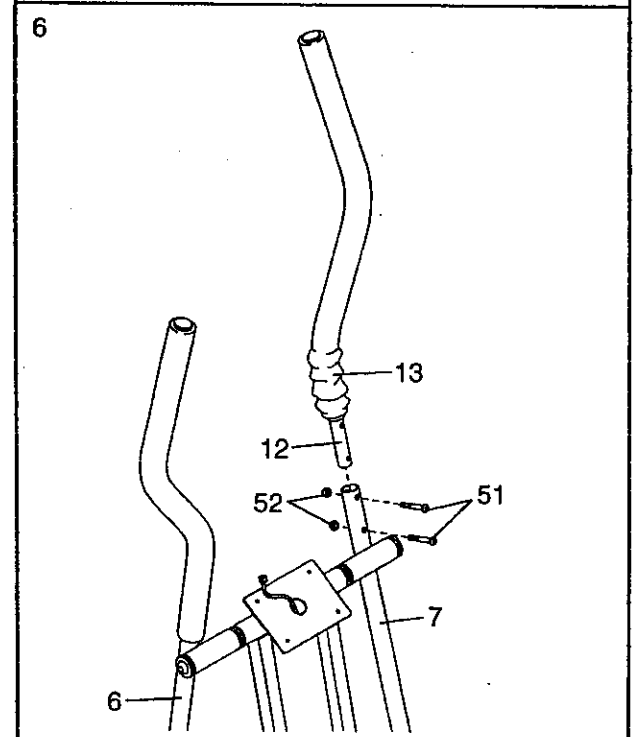

- Identify the Left Pedal Arm (14), which is marked with a sticker that has an "L" on it. Next, identify the Left Pedal (16), which has an "L" molded into the bottom. Attach the Left Pedal to the Left Pedal Arm with three M4 x 19mm Flange Screws (55).

Attach the Right Pedal to the Right Pedal Arm (not shown) in the same manner.

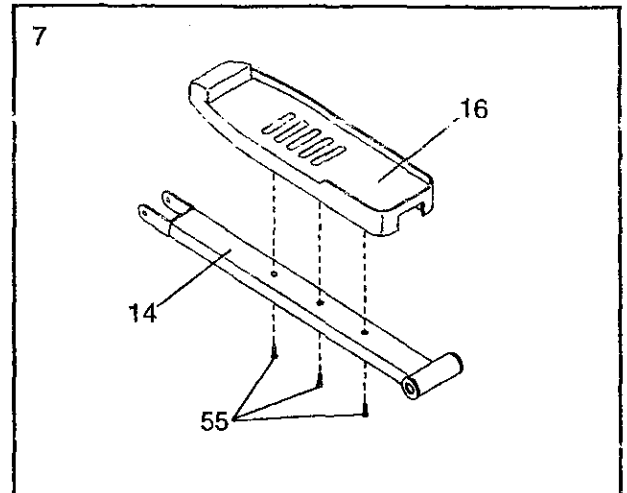

- Identify the Left Pedal Arm (14), which is marked with a sticker that has an "L" on it. Make sure that there are two Pedal Arm Bushings (33) in the Left Pedal Arm. Apply a thin film of the included grease to a Pedal Axle (34). Insert the Pedal Axle into the Left Pedal Arm, and slide a Pedal Washer (32) onto the Pedal Axle. Firmly tighten the Pedal Axle into the Crank (30). Tighten a 1/2" Nylon Locknut (35) onto the end of the Pedal Axle protruding from the Crank.

Make sure that there are two Small Pivot Bushings (42) in the Left Pivot Arm (6). Apply a thin film of the included grease to an M8 x 60mm Bolt (56). Attach the Left Pivot Arm to the Left Pedal Arm (14) with the Bolt and an M8 Nylon Locknut (50).

Attach the Right Pedal Arm (not shown) in the same manner.

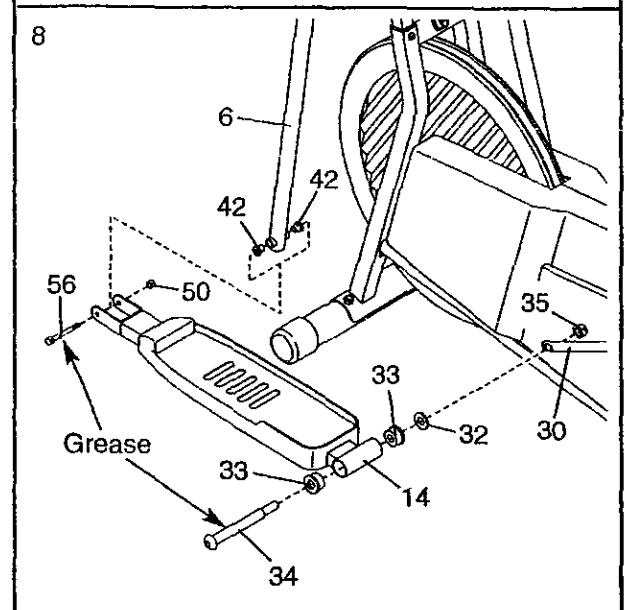

- The Console (5) requires two "AA" batteries (not included). Alkaline batteries are recommended.

To install batteries, look under the Console (5) and locate the battery compartment. Insert two batteries into the battery compartment; **make sure that the batteries are turned so the negative ends (marked "-") are touching the springs in the battery compartment.**

Connect the console wire to the Extension Wire (47). Attach the Console (5) to the Upright (2) with four M4 x 12mm Button Screws (57).

Push the Resistance Knob (28) firmly onto the Resistance Cable (29).

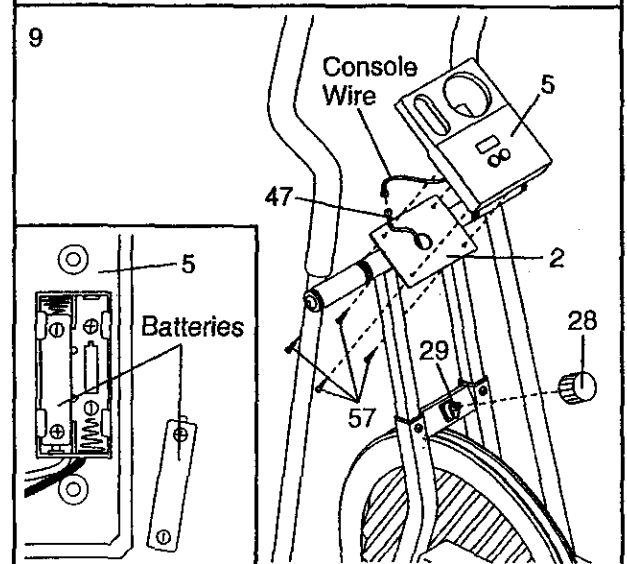

- Make sure that all parts of the elliptical glider are properly tightened. Place a mat under the elliptical glider to protect the floor or carpet from damage.



# HOW TO USE THE ELLIPTICAL GLIDER

## HOW TO EXERCISE ON THE ELLIPTICAL GLIDER

To mount the elliptical glider, firmly hold the handlebars and carefully step onto the pedal that is in the lowest position. Next, step onto the other pedal. Push the pedals until they begin to move with a continuous motion. **Note: The pedals can turn in either direction. It is recommended that you turn the pedals in the direction shown below; however, to give variety to your exercise, you may choose to turn the pedals in the opposite direction.**

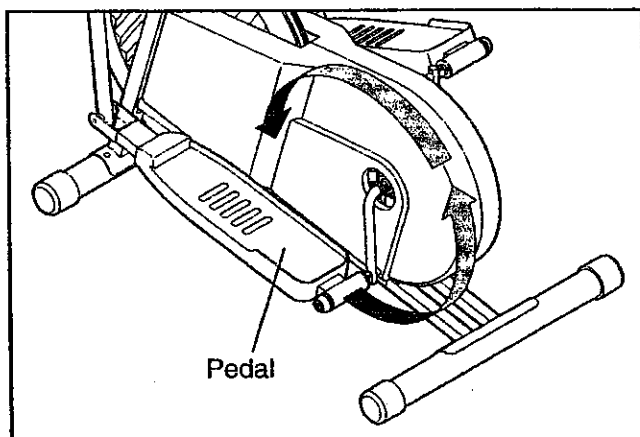

To dismount the elliptical glider, allow the pedals to come to a complete stop. **CAUTION: The elliptical glider does not have a free wheel; the pedals will continue to move until the flywheel stops.** When the pedals are stationary, step off the highest pedal first. Then, step off the lowest pedal.

## HOW TO ADJUST THE RESISTANCE OF THE PEDALS

As you exercise, you can adjust the resistance of the pedals with the resistance knob. To increase the resistance, turn the knob clockwise; to decrease the resistance, turn the knob counterclockwise.

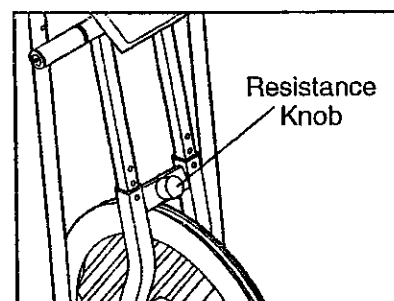

## DESCRIPTION OF THE CONSOLE

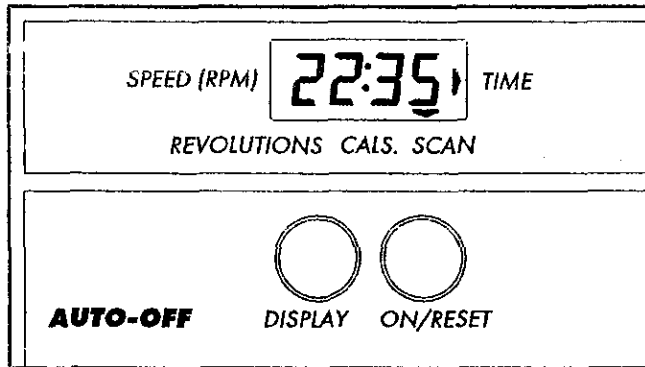

The innovative console features five modes that display instant exercise feedback. The modes are described below:

**Speed**—This mode shows your exercise pace, in revolutions per minute.

**Revolutions**—This mode shows the total number of revolutions you have pedaled.

**Calories**—This mode shows the approximate number of calories you have burned.

**Time**—This mode will show the elapsed time. Note: When you stop exercising, the time will flash when it is displayed.

**Scan**—This mode displays the other four modes, for five seconds each, in a repeating cycle.

## BATTERY INSTALLATION

Before the console can be operated, two "AA" batteries must be installed. If you have not installed batteries, see assembly step 9 on page 8. Note: It will be necessary to remove the console to install batteries.

## HOW TO OPERATE THE CONSOLE

1. To turn on the power, press the on/reset button or simply begin pedaling. When the power is turned on, the entire display will appear for two seconds. The console will then be ready for operation.

2. Select one of the five modes:

**Scan mode**—

When the power is turned on, the scan mode will automatically be selected.

One mode indicator will show that the scan mode is selected, and a flashing mode indicator will show which mode is currently displayed. Note: If a different mode is selected, you can select the scan mode again by repeatedly pressing the display button.

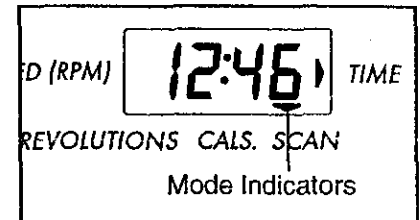

**Speed, time, revolutions, or calories mode**—To select one of these modes for continuous display,

repeatedly press the display button. The mode indicators will show which mode is selected. (Make sure that the scan mode is not selected.)

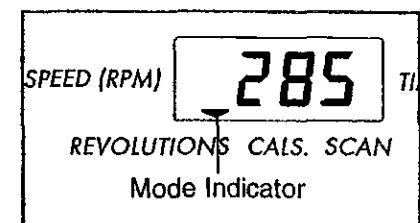

3. To reset the display, press the on/reset button.

4. To turn off the power, simply wait for about four minutes. **Note: The console has an "auto-off" feature. If the pedals are not moved and the console buttons are not pressed for four minutes, the power will turn off automatically in order to conserve the batteries.**

# CONDITIONING GUIDELINES

The following guidelines will help you to plan your exercise program. Remember that proper nutrition and adequate rest are essential for successful results.

**⚠ WARNING:** Before beginning this or any exercise program, consult your physician. This is especially important for persons over the age of 35 or persons with pre-existing health problems.

## EXERCISE INTENSITY

Whether your goal is to burn fat or to strengthen your cardiovascular system, the key to achieving the desired results is to exercise with the proper intensity. The proper intensity level can be found by using your heart rate as a guide. The chart below shows recommended heart rates for fat burning, maximum fat burning, and cardiovascular (aerobic) exercise.

HEART RATE TRAINING ZONES								
MIN	125	120	115	110	105	95	90	Fat Burn
BPM	145	138	130	125	118	110	103	Max Burn
MAX	165	155	145	140	130	125	115	Aerobic
AGE	20	30	40	50	60	70	80	

To find the proper heart rate for you, first find your age at the bottom of the chart (ages are rounded off to the nearest ten years). Next, find the three numbers above your age. The three numbers are your "training zone." The smallest number is the recommended heart rate for fat burning; the middle number is the heart rate for maximum fat burning; the largest number is the heart rate for aerobic exercise.

### Burning Fat

To burn fat effectively, you must exercise at a low intensity level for a sustained period of time. During the first few minutes of exercise, your body uses easily accessible *carbohydrate* calories for energy. Only after the first few minutes of exercise does your body begin to use stored *fat* calories for energy. If your goal is to burn fat, adjust the intensity of your exercise until your heart rate is near the smallest number in your training zone as you exercise. For maximum fat burning, adjust the intensity of your exercise until your heart rate is near the middle number.

## Aerobic Exercise

To strengthen your cardiovascular system, your exercise must be "aerobic." Aerobic exercise is activity that requires large amounts of oxygen for prolonged periods of time. This increases the demand on the heart to pump blood to the muscles, and on the lungs to oxygenate the blood. For aerobic exercise, adjust the intensity of your exercise until your heart rate is near the largest number in your training zone.

## HOW TO MEASURE YOUR HEART RATE

To measure your heart rate, first exercise for at least four minutes. Then, stop exercising and place two fingers on your wrist as shown.

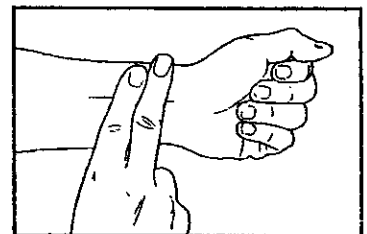

Take a six-second heartbeat count, and multiply the result by 10 to find your heart rate. For example, if your six-second heartbeat count is 14, your heart rate is 140 beats per minute. (A six-second count is used because your heart rate will drop rapidly when you stop exercising.)

## WORKOUT GUIDELINES

Each workout should include the following three parts:

**A warm-up**, consisting of 5 to 10 minutes of stretching and light exercise (see page 13). A proper warm-up increases your body temperature, heart rate, and circulation in preparation for exercise.

**Training zone exercise**, consisting of 20 to 30 minutes of exercising with your heart rate in your training zone. (During the first few weeks of your exercise program, do not keep your heart rate in your training zone for longer than 20 minutes.)

**A cool-down**, with 5 to 10 minutes of stretching. This will increase the flexibility of your muscles and will help to prevent post-exercise problems.

## EXERCISE FREQUENCY

To maintain or improve your condition, plan three workouts each week, with at least one day of rest between workouts. After a few months of regular exercise, you may plan up to five workouts each week, if desired. Remember, the key to success is make exercise a regular and enjoyable part of your everyday life.

## SUGGESTED STRETCHES

The correct form for several basic stretches is shown at the right. Move slowly as you stretch—never bounce.

### 1. Toe Touch Stretch

Stand with your knees bent slightly and slowly bend forward from your hips. Allow your back and shoulders to relax as you reach down toward your toes as far as possible. Hold for 15 counts, then relax. Repeat 3 times. Stretches: Hamstrings, back of knees and back.

### 2. Hamstring Stretch

Sit with one leg extended. Bring the sole of the opposite foot toward you and rest it against the inner thigh of your extended leg. Reach toward your toes as far as possible. Hold for 15 counts, then relax. Repeat 3 times for each leg. Stretches: Hamstrings, lower back and groin.

### 3. Calf/Achilles Stretch

With one leg in front of the other, reach forward and place your hands against a wall. Keep your back leg straight and your back foot flat on the floor. Bend your front leg, lean forward and move your hips toward the wall. Hold for 15 counts, then relax. Repeat 3 times for each leg. To cause further stretching of the achilles tendons, bend your back leg as well. Stretches: Calves, achilles tendons and ankles.

### 4. Quadriceps Stretch

With one hand against a wall for balance, reach back and grasp one foot with your other hand. Bring your heel as close to your buttocks as possible. Hold for 15 counts, then relax. Repeat 3 times for each leg. Stretches: Quadriceps and hip muscles.

### 5. Inner Thigh Stretch

Sit with the soles of your feet together and your knees outward. Pull your feet toward your groin area as far as possible. Hold for 15 counts, then relax. Repeat 3 times. Stretches: Quadriceps and hip muscles.

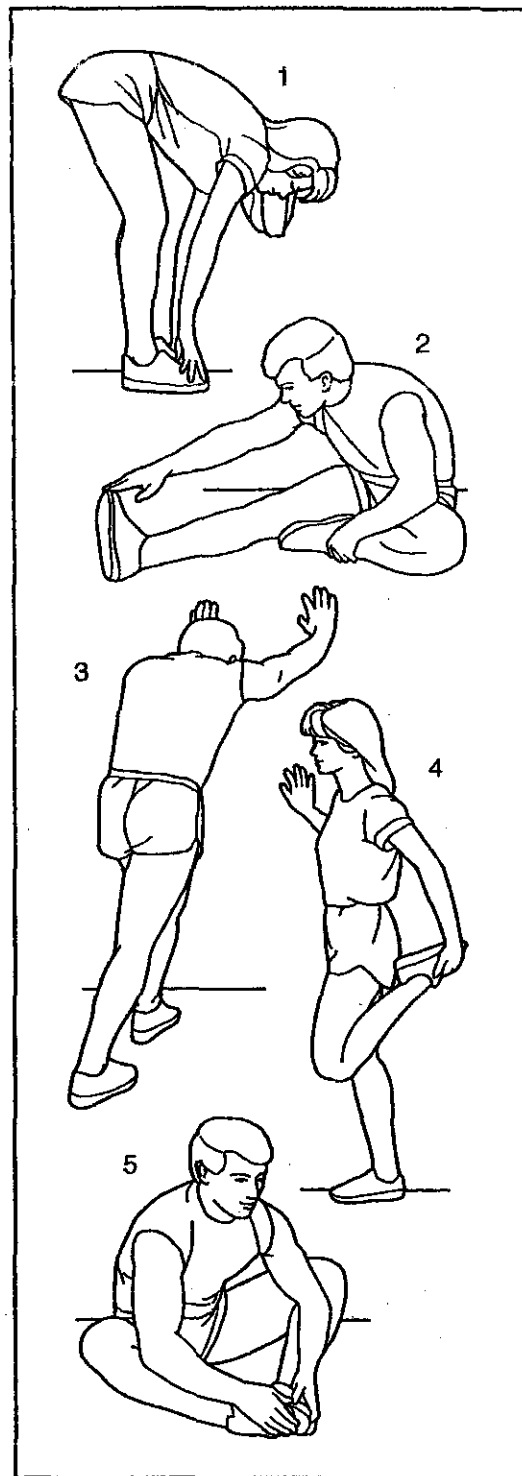

---

# MAINTENANCE

Inspect and tighten all parts of the elliptical glider regularly. Replace any worn parts immediately.

The elliptical glider can be wiped clean with a soft cloth and mild detergent. **Do not use abrasives or solvents.** To prevent damage to the console, keep liquids away from the console. Use only a sealable water bottle in the console.

## CONSOLE TROUBLE-SHOOTING

If the console does not function properly, the batteries should be replaced. To replace the batteries, refer to assembly step 9 on page 8. Note: It will be necessary to remove the console to replace the batteries.

## STORAGE

When storing the elliptical glider, remove the batteries from the console. Keep the elliptical glider in a clean, dry location, away from moisture and dust.

# PART LIST—Model No. 831.285250

R0701A

Key No.	Qty.	Description	Key No.	Qty.	Description
1	1	Frame	33	4	Pedal Arm Bushing
2	1	Upright	34	2	Pedal Axle
3	2	Frame Bushing	35	2	1/2" Nylon Locknut
4	2	Upright Endcap	36	1	Flywheel Axle
5	1	Console	37	1	Bearing Set
6	1	Left Pivot Arm	38	1	Crank Nut
7	1	Right Pivot Arm	39	1	Belt Clamp
8	2	Upright Bushing	40	1	Reed Switch Clamp
9	4	Pivot Bushing	41	1	Reed Switch Wire
10	2	M8 x 19mm Button Screw	42	4	Small Pivoi Bushing
11	1	Pivot Axle	43	2	Flywheel Washer
12	2	Handlebar	44	2	Eyebolt
13	2	Foam Grip	45	1	Belt
14	1	Left Pedal Arm	46	2	Eyebolt Nut
15	1	Right Pedal Arm	47	1	Extension Wire
16	1	Left Pedal	48	2	Handlebar Endcap
17	1	Right Pedal	49	4	M8 x 63mm Carriage Bolt
18	1	Front Stabilizer	50	10	M8 Nylon Locknut
19	1	Rear Stabilizer	51	4	M5 x 30mm Button Bolt
20	4	Stabilizer Endcap	52	4	M5 Nylon Locknut
21	1	Flywheel	53	2	M8 x 38mm Button Bolt
22	1	Resistance Belt	54	2	Pivot Washer
23	1	Resistance Spring	55	6	M4 x 19mm Flange Screw
24	1	Hook	56	2	M8 x 60mm Bolt
25	1	Cable Clamp	57	4	M4 x 12mm Button Screw
26	1	Left Side Shield	58	3	M4 x 16mm Flat Screw
27	1	Right Side Shield	59	7	M4 x 16mm Button Screw
28	1	Resistance Knob	60	4	M4 x 25mm Round Screw
29	1	Resistance Cable	#	1	User's Manual
30	1	Crank/Pulley	#	1	Allen Wrench
31	1	Magnet	#	1	Grease Packet
32	2	Pedal Washer			

Note: "#" indicates a non-illustrated part. Specifications are subject to change without notice. See the back cover of this manual for information about ordering replacement parts.

# EXPLODED DRAWING—Model No. 831.285250

R0701A

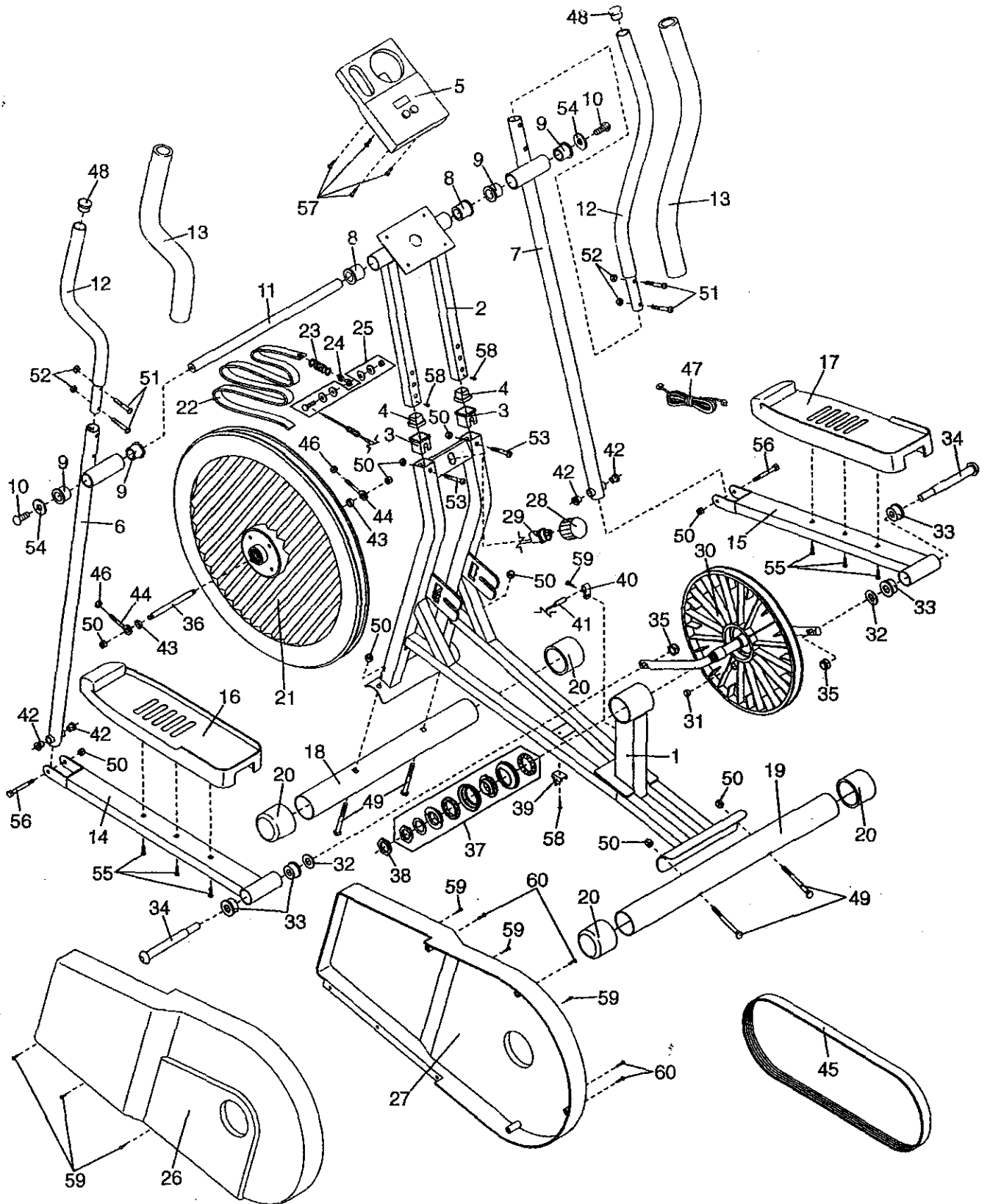

# SEARS

Model No. 831.285250

## QUESTIONS?

If you find that:

- you need help assembling or operating the LIFESTYLER® ET 30
- a part is missing
- or you need to schedule repair service

call our toll-free HELPLINE

**1-800-736-6879**

Monday–Saturday, 7 am–7 pm  
Central Time (excluding holidays)

## REPLACEMENT PARTS

If parts become worn and need to be replaced, call the following toll-free number

**1-800-FON-PART**  
**(1-800-366-7278)**

The model number and serial number of your LIFESTYLER® ET 30 are listed on a decal attached to the frame. See the front cover of this manual to find the location of the decal.

All replacement parts are available for immediate purchase or special order when you visit your nearest SEARS Service Center. To request service or to order parts by telephone, call the toll-free numbers listed at the left.

When requesting help or service, or ordering parts, please be prepared to provide the following information:

- The NAME OF THE PRODUCT (LIFESTYLER® ET 30)
- The MODEL NUMBER OF THE PRODUCT (831.285250)
- The KEY NUMBER OF THE PART (see page 15)
- The DESCRIPTION OF THE PART (see page 14).

## FULL 90 DAY WARRANTY

For 90 days from the date of purchase, if failure occurs due to defect in material or workmanship in this SEARS ELLIPTICAL EXERCISER, contact the nearest SEARS Service Center throughout the United States and SEARS will repair or replace the ELLIPTICAL EXERCISER, free of charge.

This warranty does not apply when the ELLIPTICAL EXERCISER is used commercially or for rental purposes.

This warranty gives you specific legal rights, and you may also have other rights which vary from state to state.

**SEARS, ROEBUCK AND CO., DEPT. 817WA, HOFFMAN ESTATES, IL 60179**