

HITACHI

VIDEO CASSETTE RECORDER

VT-UX6450A

Owner's manual



VCR plus+3 Cable box control

MOVIE → ADVANCE™

Using these quality features:

- The VCR Plus+* programming system allows you to program the VCR for timer recording by simply entering a PlusCode* number.

*VCR Plus+C³ and PlusCode are trademarks of Gemstar Development Corporation.

The VCR Plus+ system is manufactured under license from Gemstar Development Corporation.

With the VCR Plus+C³ system, this video cassette recorder can automatically select the appropriate channel on your compatible cable box or satellite receiver. C³ and VCR Plus+C³ are trademarks of Gemstar Development Corporation.

• **MOVIE → ADVANCE™**

"MOVIE ADVANCE™ is a trademark of SRT, Inc. A Jerry Iggulden invention licensed in association with Arthur D. Little Enterprises, Inc."

- **S-VHS** Quasi playback allows you to playback the tape that is recorded by S-VHS type.
- Super rewind and fast forward.
- Multi-channel TV sound (MTS).
- 8-program/1-year preset recording.
- Auto clock set feature allows you to automatically set the present time using a time signal.
- Auto head cleaning system minimizes the need for accessory cleaners and professional head cleaning.
- Auto tracking system automatically adjusts the tracking so the picture is optimized.
- Frequency synthesized tuner provides easy, preset tuning of up to 68 broadcast TV channels and 125 cable channels.
- VHS Hi-Fidelity sound in playback.
- Illuminated remote control for use with your VCR
- On-screen programming guide.
- With display, VCR Plus+ can be programmed to record without turning power on.

**HITACHI HOME ELECTRONICS
(AMERICA), INC.**
3890 Steve Reynolds Blvd,
Norcross, GA 30093
Tel. 770-279-5600

HITACHI (HSC) CANADA INC.
6740 Campobello Road
Mississauga, Ontario L5N 2L8
CANADA
Tel. 905-821-4545

TABLE OF CONTENTS

FOR YOUR SAFETY.....	4
IMPORTANT SAFEGUARDS.....	5
INSTALLATION	5
USE	6
SERVICE	7
CUSTOMER CONTROLS	8
REMOTE OPERATION	11
Operating in the remote control.....	12
CASSETTE TAPES.....	13
Types	13
Safety tabs prevent erasure	13
Insertion	13
Removal.....	14
BASIC ANTENNA HOOKUP [A].....	15
ADVANCED ANTENNA HOOKUP -AV HOOKUP [B]	17
BASIC CABLE HOOKUP [C]	18
ADVANCED CABLE HOOKUP -AV HOOKUP [D]	20
BASIC CABLE HOOKUP -WITH CABLE BOX [E].....	21
ADVANCED CABLE HOOKUP -WITH CABLE BOX [F].....	23
ADVANCED CABLE HOOKUP -WITH CABLE BOX AND SPLITTER [G]	24
SETTING THE CLOCK - AUTOMATIC MODE.....	25
Auto clock set function	25
Setting the clock automatically - if your VCR's hooked up to an antenna or cable without a cable box (Hookups [A], [B], [C] or [D])	25
SETTING THE CLOCK -AUTOMATIC MODE WITH CABLE BOX	26
If your VCR is hooked up to a cable box (Hookups [E], [F] or [G])	26
SETTING THE CLOCK -TIME ZONE SETTING/DAYLIGHT SAVING TIME SETTING	28
What to do if the displayed time drifts from the current time by more than an hour	28
SETTING THE CLOCK -MANUALLY	30
PRE-TUNING THE VCR TUNER	33
To add or erase channels	34
Auto blue setting	35
CABLE BOX SETUP	37
PLAYBACK.....	41
Rewinding the tape	41
Rewinding the tape	41
To remove noise from the picture	41
Rewinding or fast forwarding a tape at high speed	42
SPECIAL PLAYBACK EFFECTS	43
Variable speed playback.....	43
Still Playback (Pause)	43
Frame Advance.....	43
Skip Playback	43
Slow Motion	43
Visual Search.....	44
Choosing a mode for audio playback.....	44
How to select playback audio.....	44
Locating the start of movie	45

Locating the start of preview	46
SHUTTLE CONTROL	48
Using the shuttle ring on the remote control.....	48
How to use the shuttle ring.....	48
USING THE "INDEX" FEATURE	49
To find specific sections on a tape using the "INDEX" feature.....	49
VIEWING THE ON-SCREEN DISPLAY	50
Switching between the clock, time counter and time of remaining tape.....	50
INDEX WITH THE TIME COUNTER	51
To find specific sections on a tape	51
RECORDING A PROGRAM	52
Before you record	52
Basic recording steps.....	52
RECORDING A PROGRAM -RECORDING TIPS	54
To watch one program while recording another.....	54
To change the channel being recorded.....	54
To record a Second Audio Program (SAP).....	54
Stereo vs. mono sound	55
INSTANT RECORDING TIMER	56
Using the Instant Recording Timer (IRT)	56
DELAYED RECORDING	57
USING THE VCR PLUS+ SYSTEM FOR RECORDING	61
About the VCR Plus+ system.....	61
Channel setup.....	61
EASY DELAYED RECORDING WITH THE VCR PLUS+ SYSTEM	63
VCR Plus+ setup - Channel setup	63
Using the VCR Plus+ system to record a program (by using TV screen).....	64
Using the VCR Plus+ system to record a program (by using VCR's display).....	67
PROGRAM REVIEW	69
Reviewing what you have programmed.....	69
PROGRAMMING THE VCR REMOTE TO CONTROL YOUR TV	70
PROGRAMMING THE VCR REMOTE TO CONTROL YOUR CABLE BOX	71
INTEGRATING YOUR STEREO SYSTEM WITH YOUR VCR	72
Hookup	72
To record from stereo	72
COPYING TAPES FROM A CAMCORDER	74
Hookup	74
To copy from a camcorder	74
COPYING FROM ONE VCR TO ANOTHER VCR (DUBBING)	76
Hookup	76
To copy from one VCR to another VCR.....	76
PROBLEM GUIDE / MAINTENANCE	77
Problem guide.....	77
Maintenance	77
TECHNICAL SPECIFICATIONS	79

FOR YOUR SAFETY

POWER SUPPLY: AC 120V, 60 Hz ONLY.

The POWER button turns the VCR on and off, leaving the clock/timer unaffected. If the unit is to be left unattended for a long period, it is recommended that the unit be completely switched off and unplugged.

Illustrated below is the label on the back of your unit.

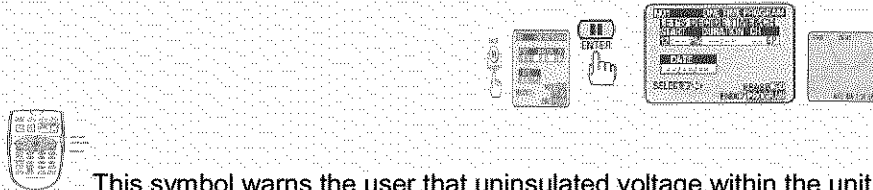

This symbol warns the user that uninsulated voltage within the unit may have sufficient magnitude to cause electric shock. Therefore, it is dangerous to make any kind of contact with any inside part of this unit.

This symbol alerts the user that important literature concerning the operation and maintenance of this unit has been included. Therefore, it should be read carefully in order to avoid any problems.

CAUTION: TO REDUCE THE RISK OF ELECTRIC SHOCK, DO NOT REMOVE COVER (OR BACK). NO USER-SERVICEABLE PARTS INSIDE. REFER SERVICING TO QUALIFIED SERVICE PERSONNEL.

WARNING: Many television programs and films are copyrighted. In certain circumstances, copyright law may apply to private in-home videotaping of copyrighted materials.

WARNING: TO PREVENT FIRE OR ELECTRIC SHOCK, DO NOT EXPOSE THIS APPLIANCE TO RAIN OR MOISTURE.

CAUTION: TO PREVENT ELECTRIC SHOCK, MATCH WIDE BLADE OF POWER PLUG TO WIDE SLOT OF AC OUTLET AND FULLY INSERT.

Caution to the user: Changes or modifications not expressly approved by the party responsible for compliance could void the user's authority to operate the equipment.

"Note to CATV system installer: This reminder is provided to call the CATV system installer's attention to Article 820-40 of the NEC that provides guidelines for proper grounding and, in particular, specifies that the cable ground shall be connected to the grounding system of the building, as close to the point of cable entry as practical".

IMPORTANT SAFEGUARDS

In addition to the careful attention devoted to quality standards in the manufacture of your video product, safety is a major factor in the design of every instrument. But, safety is your responsibility too.

This page lists important information that will help to assure your enjoyment and proper use of a Video Cassette Recorder and accessory equipment. Please read it carefully before operating your video product and keep it in a handy place for future reference.

INSTALLATION

1 Read and Follow Instructions – All the safety and operating instructions should be read before the video product is operated. Follow all operating and use instructions.

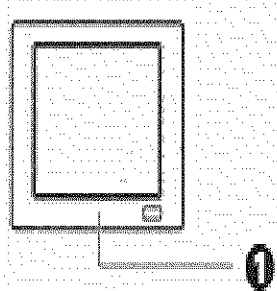

2 Retain Instruction – The safety and operating instructions should be retained for future reference.

3 Heed Warnings – Comply with all warnings on the video product and in the operating instructions.

4 Polarized Plug – This video product is equipped with a polarized alternating current line plug (a plug having one blade wider than the other). This plug will fit into the power outlet only one way. This is a safety feature. If you are unable to insert the plug fully into the outlet, try reversing the plug. If the plug should still fail to fit, contact your electrician to replace your obsolete outlet. To prevent electric shock do not use this polarized plug with an extension cord, receptacle or other outlet unless the blades can be fully inserted without blade exposure. If you need an extension, use a polarized cord.

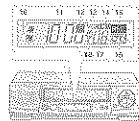

5 Power Sources – This video product should be operated only from the type of power source indicated on the marking label. If you are not sure of the type of power supply to your home, consult your video dealer or local power company. For video products intended to operate from battery power, or other sources, refer to the operating instructions.

6 Overloading – Do not overload wall outlets and extension cords as this can result in a risk of fire or electric shock. Overloaded AC outlets and extension cords are dangerous, and so are frayed power cords, damaged or cracked wire insulation and broken plugs. They may result in a shock or fire hazard. Periodically examine the cord and have it replaced by your service technician if appearance indicates damage or deteriorated insulation.

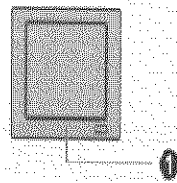

7 Power-Cord Protection – Power supply cords should be routed so that they are not likely to be walked on or pinched by items placed upon or against them, paying particular attention to cords at plugs, convenience receptacles, and the point where they exit from the appliance.

8 Ventilation – Slots and openings in the cabinet are provided for ventilation to ensure reliable operation of the video product and to protect it from overheating. These openings must not be blocked or covered. The openings should never be blocked by placing the video product on a bed, sofa, rug or other similar surface. This video product should never be placed near or over a radiator or heat register. This video product should not be placed in a built-in installation such as a bookcase or rack unless proper ventilation is provided or the video product manufacturer's instructions have been followed.

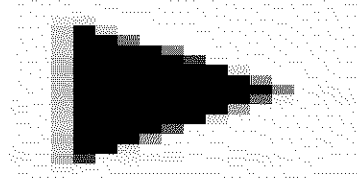

9 Attachments – Do not use attachments unless recommended by the video product manufacturer as they may cause hazards.

Caution: Maintain electrical safety. Powerline operated equipment or accessories connected to this unit should bear the UL listing mark or CSA certification mark on the accessory itself and should not have been modified so as to defeat the safety features. This will help avoid any potential hazard from electric shock or fire. If in doubt, contact qualified service personnel.

10 Water and Moisture – Do not use this video product near water - for example, near a bath tub, wash bowl, kitchen sink, or laundry tub, in a wet basement, or near a swimming pool, and the like.

11 Accessories – Do not place this video product on an unstable card, stand, tripod, bracket or table. The video product may fall, causing serious injury to a child or adult, and serious damage to the appliance. Use only with a cart, stand, tripod, bracket or table recommended by the manufacturer, or sold with the video product. Any mounting of the product should follow the manufacturer's instructions, and should use a mounting accessory recommended by the manufacturer.

11A An appliance and cart combination should be moved with care. Quick stops, excessive force, and uneven surfaces may cause the appliance and cart combination to overturn.

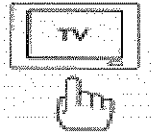

12 Outdoor Antenna Grounding – If an outside antenna or cable system is connected to the video product, be sure the antenna or cable system is grounded so as to provide some protection against voltage surges and built-up static charges. Section 810 of the National Electrical Code, ANSI/NFPA No. 70, provides information with respect to proper grounding of the mast and supporting structure, grounding of the lead-in wire to an antenna discharge unit, size of grounding conductors, location of antenna-discharge unit, connection to grounding electrodes, and requirements for the grounding electrode. See example below.

EXAMPLE OF ANTENNA GROUNDING

13 Power Lines – An outside antenna system should not be located in the vicinity of overhead power lines or other electric light or power circuits, or where it can fall into such power lines or circuits. When installing an outside antenna system, extreme care should be taken to keep from touching or approaching such power lines or circuits as contact with them might be fatal. Installing an outdoor antenna can be hazardous and should be left to a professional antenna installer.

USE

14 Cleaning – Unplug this video product from the wall outlet before cleaning. Do not use liquid cleaners or aerosol cleaners. Use a damp cloth for cleaning.

15 Object and Liquid Entry – Never push objects of any kind into this video product through openings as they may touch dangerous voltage points or short-out parts that could result in a fire or electric shock. Never spill liquid of any kind on the video product.

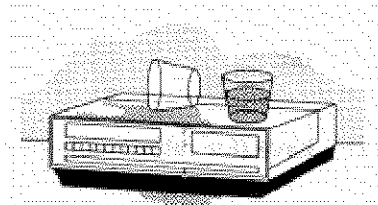

16 Lightning – For added protection for this video product during a lightning storm, or when it is left unattended and unused for long periods of time, unplug it from the wall outlet and disconnect the antenna or cable-system. This will prevent damage to the video product due to lightning and power-line surges.

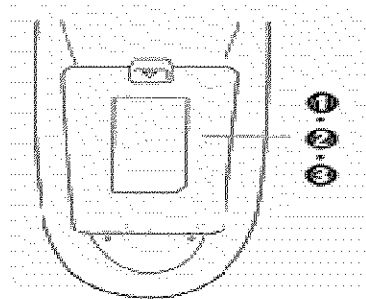

SERVICE

17 Servicing – Do not attempt to service this video product yourself as opening or removing covers may expose you to dangerous voltage or other hazards. Refer all servicing to qualified service personnel.

18 Conditions Requiring Service – Unplug this video product from the wall outlet and refer servicing to qualified service personnel under the following conditions.

- a. When the power-supply cord or plug is damaged.
- b. If liquid has been spilled, or objects have fallen into the video product.
- c. If the video product has been exposed to rain or water.
- d. If the video product does not operate normally by following the operating instructions. Adjust only those controls that are covered by the operating instructions. Improper adjustment of other controls may result in damage and will often require extensive work by a qualified technician to restore the video product to its normal operation.
- e. If the video product has been dropped or the cabinet has been damaged.
- f. When the video product exhibits a distinct change in performance - this indicates a need for service.

19 Replacement Parts – When replacement parts are required, have the service technician verify that the replacements he uses have the same safety characteristics as the original parts. Use of replacements specified by the video product manufacturer can prevent fire, electric shock or other hazards.

20 Safety Check – Upon completion of any service or repairs to this video product, ask the service technician to perform safety checks recommended by the manufacturer to determine that the video product is in safe operating condition.

CUSTOMER CONTROLS

VCR Customer Controls

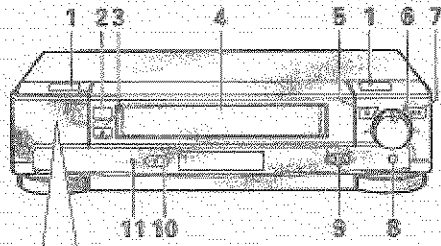

To open the cover:
Pull the cover forward with your fingers.

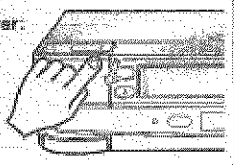

Item No.	Function	Page
1	Infrared transmitter	25
2	POWER button	2
3	EJECT button	9
4	Cassette compartment	9
5	STOP button	23
6	Shuttle ring	35
7	PLAY/STILL button	30
8	REC/IRT button	40
9	CHANNEL (channel up/down) TRACKING buttons	23 29
10	Infrared receiver	8
11	REC indicator	40

Behind the cover

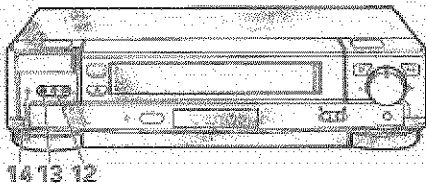

12	AUDIO IN L (MONO), R jacks	58
13	VIDEO IN jack	58
14	ANT. OUT select button	10

VCR Display

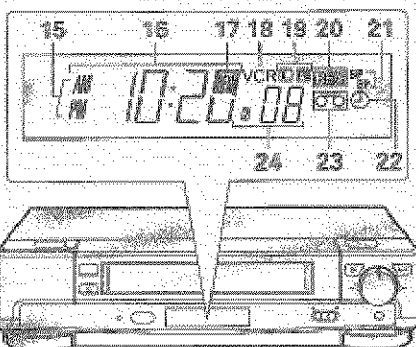

15	AM/PM indicators	18
16	Time,	17

	Tape counter,	37	
	Tape remaining or	37	
	VCR mode indicator	28	
	PLAY - playback		28
	SRCH - double-speed play		31
	and visual search ["-" appears		
	during reverse direction viewing]		
	SLOW - slow play	31	
	REW - rewind	28	
	S:REW - high speed rewind	29	
	FF - fast forward		-
	S:FF - high speed fast forward	29	
	STILL - play pause and frame advance	30	
17	REM (tape remaining time) indicator	37	
18	VCR, operate mode	41	
19	Audio indicators	32	
20	REC - record (flashes during		
	record pause)	40	
21	Tape speed SP/EP	39	
22	Delayed recording indicator	46	
23	Tape-in indicator		9
24	TV channel or	39	
	Auxiliary (L1/L2)	56	

Accessories supplied

Check and identify the accessories supplied.
If any are missing or appear damaged, consult your dealer.



1.

Remote Control Cable for connecting
this VCR to a TV

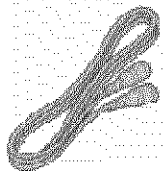

2.



3.

Batteries for remote
control handset (R6)

VCR Customer Controls

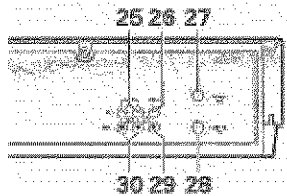

Item No.	Function	Page
25	AUDIO IN (L), (R) jacks	56
26	VIDEO IN jack	58
27	IN FROM ANT. - signal input	10
28	OUT TO TV - signal out to TV	10
29	VIDEO OUT jack	11
30	AUDIO OUT (L), (R) jacks	11

Remote Control Customer Controls

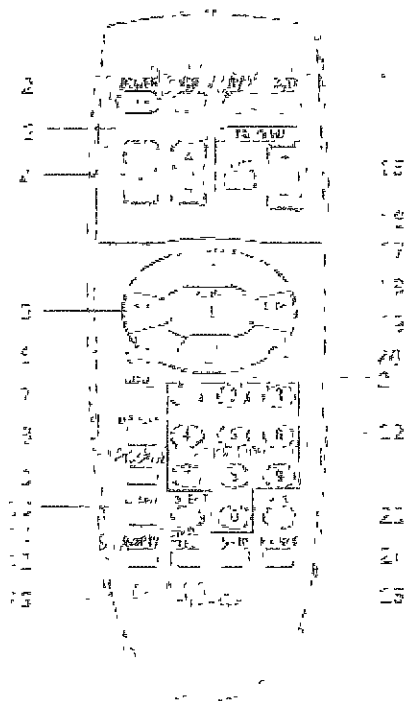

Item No.	Function	Page
1	Transmission window	8
2	POWER button	22
3	CH (channel up/down) button	39
4	VOL button - increase or decrease the audio volume	54
5	FEW button - fast rewind or search	28
6	REC - record button	40
7	GUIDE -to recall OSD menu	22
8	DISPLAY -to recall on-screen display	36
9	PROGRAM (programming) button	44
10	CLEAR - clears time counter	38
11	100/ENT button	39
12	VCR/TV mode select button	10
13	TAPE SPEED button	39
14	VCR, TV, CATV - device buttons let you set the remote to control one of the three devices	54/55
15	TRACKING button	29
16	AUTO TRACKING button	29
17	PLAY button - playback	23
18	PAUSE button	30
19	F.FWD button - fast forward or search	31
20	SLOW button	31
21	STOP button - stops play/record function	23
22	Number buttons	22
23	AVX button - select LI or L2	56
24	MA SKIP button	33
25	SKIP button	30

* If you want to operate the VCR with remote control after operating the TV, first press the VCR button, and then press required buttons on the remote control

REMOTE OPERATION

Install batteries in the remote control

The remote control requires two "AA" batteries.

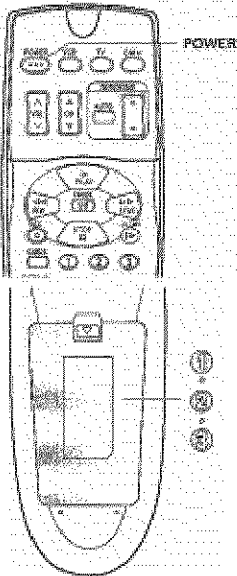

1 Push the tab of the battery compartment cover in the direction of the arrow to remove the cover.

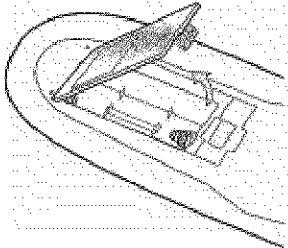

Note: When replacing the batteries, remove the old batteries and keep the POWER button depressed for 10 seconds before inserting fresh batteries.



Hold for 10 seconds

2 Install batteries.

- Align the positive (+) and negative (-) polarity marks on the batteries with those indicated on the remote control.

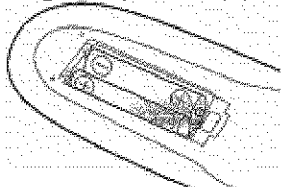

3 Replace the cover.

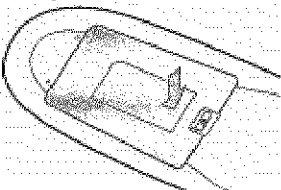

Operating in the remote control

Operating the VCR:

1 Make sure there is no obstacle between the remote control and VCR's infrared receiver.

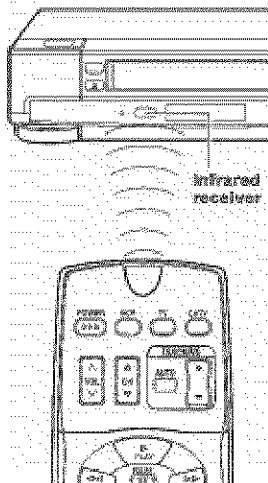

Note: You cannot operate the VCR if there is an obstacle (for example, coffee table, sofa, etc) between the VCR and remote control.

2 Point the remote control at the VCR's infrared receiver and press the required button on the remote control.

Note: If the remote does not work even at close range, try replacing the batteries with two fresh "AA" batteries.

About the illuminated buttons:

- When you press any of the illumination buttons, the illumination will turn on.
- The illumination goes off 5 seconds later automatically, if you do not press the buttons.

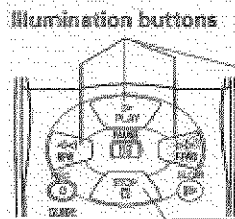

CASSETTE TAPES

Types

Only use video cassettes with the  mark in this VCR.



The table shows the recording time of different cassettes.

Types	Recording time	
SP	EP	
T-120	120 min.	360 min.
T-160	160 min.	480 min.
T-180	180 min.	540 min.
T-210	210 min.	630 min.

- To get the best quality picture, record at standard recording speed (SP).
- This VCR does not record at the LP speed, but it can play cassette that were recorded at the LP speed.

Safety tabs prevent erasure

To avoid erasing a recording

Break off the safety tab using a screwdriver or similar tool.

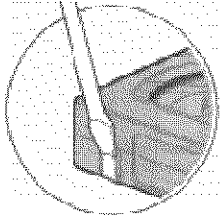

To re-record on a cassette which has its safety tab removed

Cover the hole with plastic tape.

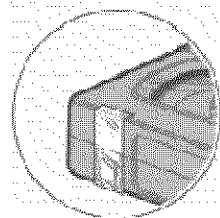

The VCR automatically enters the playback mode when a cassette without its safety tab is inserted. **The VCR won't record on a tape without a safety tab and the cassette will be ejected if the REC or REC/IRT button is pressed.** Be sure to check the safety tab before inserting a cassette.

Insertion

Push the video cassette gently into the slot on the front of the VCR.

- The VCR automatically turns on and the "Tape-In" indicator  turns on when the cassette is in place.

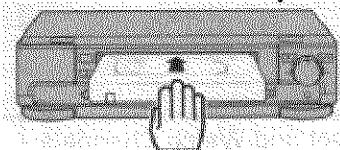

Removal

Press the EJECT button on the VCR.

The cassette will come partially out of the compartment so you can pull it out.

- The "Tape-In" indicator  turns off.
- The cassette can be ejected with the power on or off.

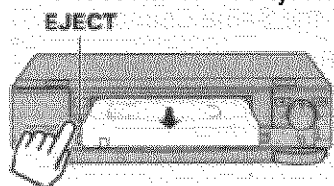

**BASIC ANTENNA HOOKUP [A]
WITH THIS HOOKUP**

YOU CAN...

- WATCH AVAILABLE TV CHANNELS
- RECORD AND WATCH THE SAME CHANNEL
- RECORD ONE CHANNEL AND WATCH ANOTHER

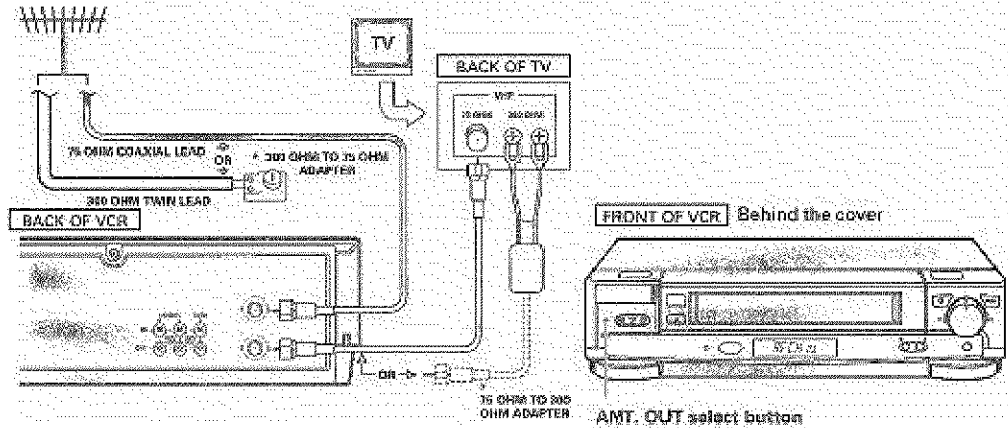

Basic Hookup with Antenna: RF Hookup

* PURCHASED SEPARATELY

TABLE A

FUNCTION	CHANNEL SELECTION		VCR indicator (Press the VCR/TV mode select button to turn the VCR indicator on and off.)
TV	VCR		
Select and Watch Channels using TV	Select Channel to Watch		OFF (TV mode)
Select and Watch Channels using VCR	3 or 4	Select Channel to Watch	ON (VCR mode)
Record and Watch the Same Channel	3 or 4	Select Channel to Record	ON (VCR mode)
Record One Channel Watch Another	Select Channel to Watch	Select Channel to Record	OFF (TV mode)
Watch Playback of a Tape	3 or 4		ON (VCR mode)

Switch the RF Channel

When the VCR is on, its video signal can come into your TV on either channel 3 or channel 4. You need to select the appropriate channel.

- Turn on the power of both the TV and the VCR. Press the ANT. OUT button on front of the VCR. Pressing the

button alternates between RFCH 03 (channel 3) and RFCH 04 (channel 4) in the VCR's display. Display the channel which is not used by a commercial channel in your area.

**ADVANCED ANTENNA HOOKUP -AV HOOKUP [B]
WITH THIS HOOKUP**

YOU CAN...

- WATCH AVAILABLE TV CHANNELS
- RECORD AND WATCH THE SAME CHANNEL
- RECORD ONE CHANNEL AND WATCH ANOTHER

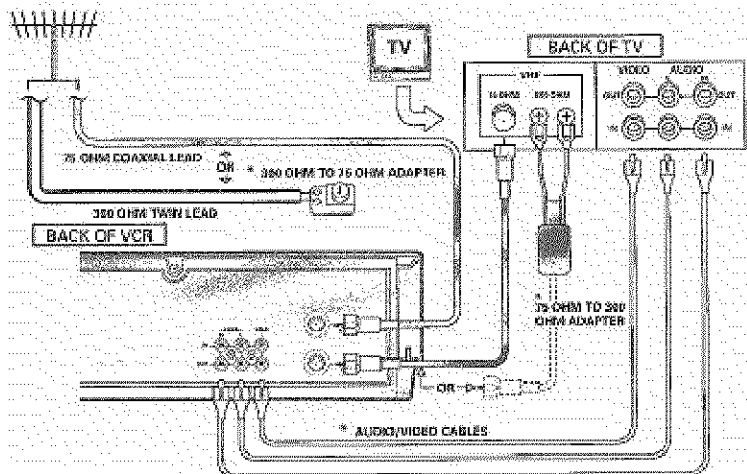

Advanced Hookup with Antenna: AV Hookup

* PURCHASED SEPARATELY

TABLE B

FUNCTION	CHANNEL SELECTION		VCR indicator (Press the VCR/TV mode select button to turn the VCR indicator on and off.)
TV	VCR		
Select and Watch Channels using TV	Select Channel to Watch		OFF (TV mode)
Select and Watch Channels using VCR	AUX or VIDEO	Select Channel to Watch	
Record and Watch the Same Channel	AUX or VIDEO	Select Channel to Record	
Record One Channel Watch Another	Select Channel to Watch	Select Channel to Record	OFF (TV mode)
Watch Playback of a Tape	AUX or VIDEO		

**BASIC CABLE HOOKUP [C]
WITH THIS HOOKUP**

YOU CAN...

- WATCH AVAILABLE CABLE CHANNELS
- RECORD AND WATCH THE SAME CHANNEL
- RECORD ONE CHANNEL AND WATCH ANOTHER

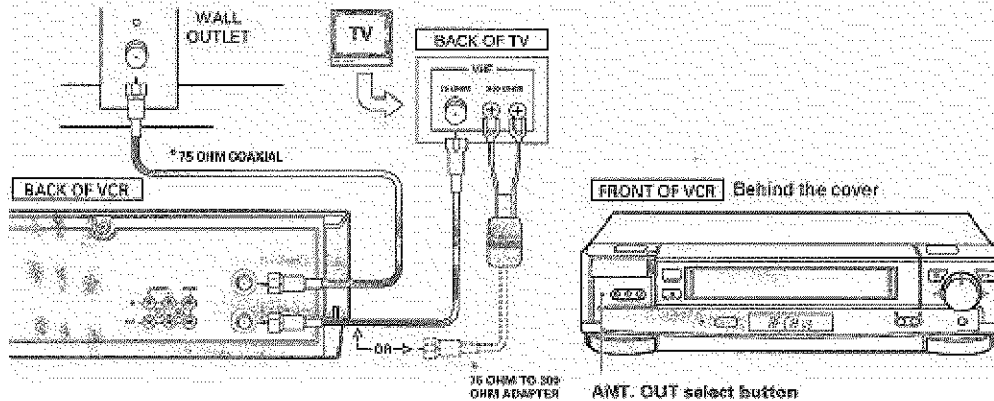

Basic Hookup with Cable: RF Hookup

* PURCHASED SEPARATELY

TABLE C

FUNCTION	CHANNEL SELECTION		VCR indicator (Press the VCR/TV mode select button to turn the VCR indicator on and off.)
TV	VCR		
Select and Watch Channels using TV	Select Channel to Watch		OFF (TV mode)
Select and Watch Channels using VCR	3 or 4	Select Channel to Watch	ON (VCR mode)
Record and Watch the Same Channel	3 or 4	Select Channel to Record	ON (VCR mode)
Record One Channel Watch Another	Select Channel to Watch	Select Channel to Record	OFF (TV mode)
Watch Playback of a Tape	3 or 4		ON (VCR mode)

Switch the RF Channel

When the VCR is on, its video signal can come into your TV on either channel 3 or channel 4. You need to select the appropriate channel.

- Turn on the power of both the TV and the VCR. Press the ANT. OUT button on front of the VCR. Pressing the button alternates between RFCH 03 (channel 3) and RFCH 04 (channel 4) in the VCR's display.

Display the channel which is not used by a commercial channel in your area.

**ADVANCED CABLE HOOKUP -AV HOOKUP [D]
WITH THIS HOOKUP**

YOU CAN...

- WATCH AVAILABLE CABLE CHANNELS
- RECORD AND WATCH THE SAME CHANNEL
- RECORD ONE CHANNEL AND WATCH ANOTHER

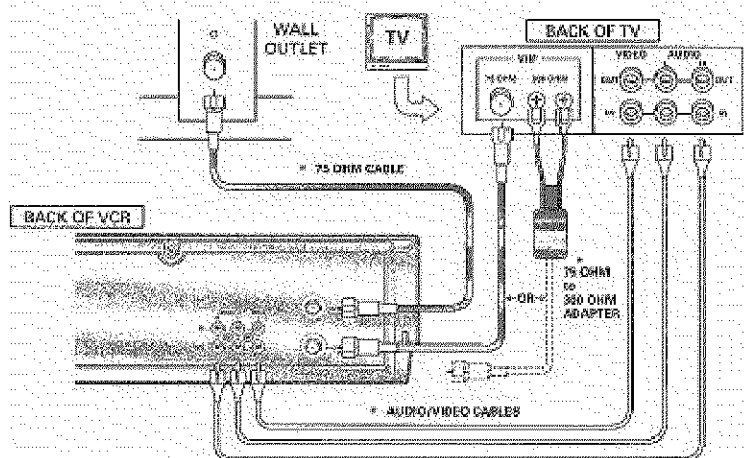

Advanced Hookup with Cable: AV Hookup

* PURCHASED SEPARATELY

TABLE D

FUNCTION	CHANNEL SELECTION		VCR indicator (Press the VCR/TV mode select button to turn the VCR indicator on and off.)
TV	VCR		
Select and Watch Channels using TV	Select Channel to Watch		OFF (TV mode)
Select and Watch Channels using VCR	AUX or VIDEO	Select Channel to Watch	
Record and Watch the Same Channel	AUX or VIDEO	Select Channel to Record	
Record One Channel Watch Another	Select Channel to Watch	Select Channel to Record	OFF (TV mode)
Watch Playback of a Tape	AUX or VIDEO		

BASIC CABLE HOOKUP -WITH CABLE BOX [E]

WITH THIS HOOKUP

YOU CAN...

- WATCH AVAILABLE CABLE CHANNELS
- RECORD AND WATCH THE SAME CHANNEL

YOU CANT'...

- RECORD ONE CHANNEL AND WATCH ANOTHER

ALL CHANNEL SELECTIONS MUST BE MADE AT THE CABLE BOX.
BE SURE TO CONSULT YOUR CABLE BOX MANUAL FOR THE CABLE BOX OUTPUT CHANNEL.

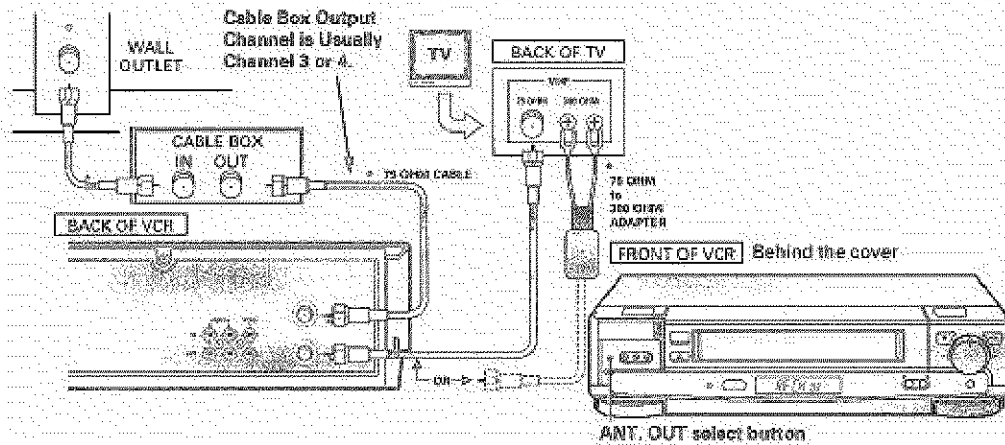

Basic Hookup with Cable Box: RF Hookup

* PURCHASED SEPARATELY

TABLE E

FUNCTION	CHANNEL SELECTION			VCR indicator (Press the VCR/TV mode select button to turn the VCR indicator on and off.)
TV	VCR	CABLE BOX		
Watch Cable Channels on TV	Select Cable box output Channel		Select Channel to Watch	OFF (TV mode)
Select and Watch Channels using VCR	3 or 4	Select Cable box output Channel	Select Channel to Watch	ON (VCR mode)
Record and Watch the Same Channel	3 or 4	Select Cable box output Channel	Select Channel to Watch	ON (VCR mode)
Record One Channel Watch Another				
Watch Playback of a Tape	3 or 4			ON (VCR mode)

Switch the RF Channel

When the VCR is on, its video signal can come into your TV on either channel 3 or channel 4. You need to select the appropriate channel.

- Turn on the power of both the TV and the VCR. Press the ANT. OUT button on front of the VCR. Pressing the button alternates between RFCH 03 (channel 3) and RFCH 04 (channel 4) in the VCR's display. Display the channel which is not used by a commercial channel in your area.

ADVANCED CABLE HOOKUP -WITH CABLE BOX [F]

WITH THIS HOOKUP

YOU CAN...

- WATCH AVAILABLE CABLE CHANNELS
- RECORD AND WATCH THE SAME CHANNEL

YOU CANT'...

- RECORD ONE CHANNEL AND WATCH ANOTHER

ALL CHANNEL SELECTIONS MUST BE MADE AT THE CABLE BOX.
BE SURE TO CONSULT YOUR CABLE BOX MANUAL FOR THE CABLE BOX.

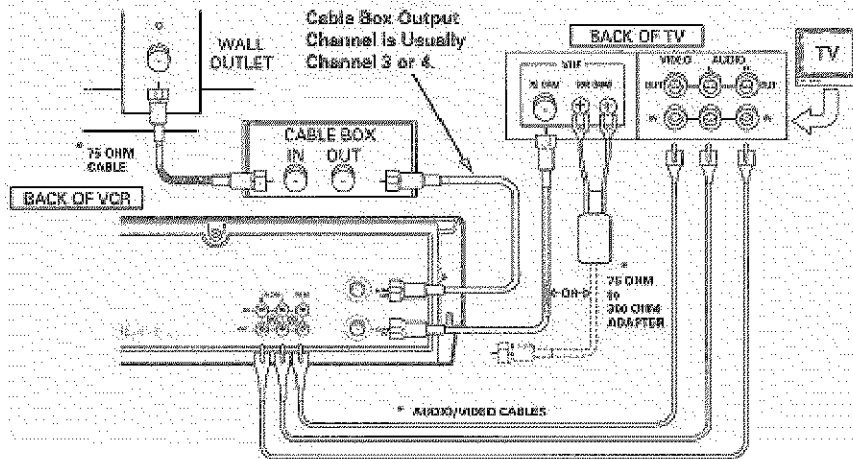

Advanced Hookup with Cable Box: AV Hookup

* PURCHASED SEPARATELY

TABLE F

FUNCTION	CHANNEL SELECTION			VCR indicator (Press the VCR/TV mode select button to turn the VCR indicator on and off.)
TV	VCR	CABLE BOX		
Watch Cable Channels on TV	Select Cable box output Channel		Select Channel to Watch	OFF (TV mode)
Select and Watch Channels using VCR	AUX or VIDEO	Select Cable box output Channel	Select Channel to Watch	
Record and Watch the Same Channel	AUX or VIDEO	Select Cable box output Channel	Select Channel to Watch	
Record One Channel Watch Another				
Watch Playback of a Tape	AUX or VIDEO			

ADVANCED CABLE HOOKUP -WITH CABLE BOX AND SPLITTER [G]

WITH THIS HOOKUP

YOU CAN...

- WATCH AVAILABLE CABLE CHANNELS
- RECORD AND WATCH THE SAME CHANNEL
- RECORD ONE CHANNEL AND WATCH ANOTHER

TO RECORD, ALL CHANNEL SELECTIONS MUST BE MADE AT THE CABLE BOX.
BE SURE TO CONSULT YOUR CABLE BOX MANUAL FOR THE CABLE BOX OUTPUT CHANNEL.

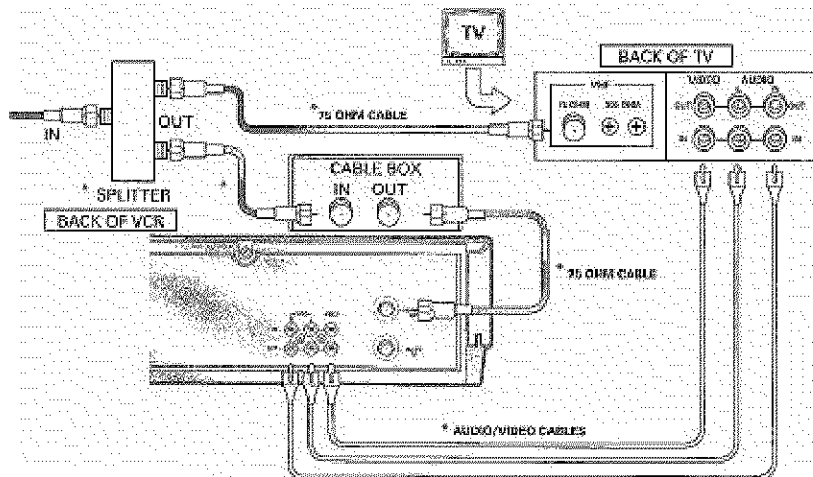

Advanced Hookup with Cable Box and Splitter: AV and RF Hookup

* PURCHASED SEPARATELY

TABLE G

FUNCTION	CHANNEL SELECTION			VCR indicator (Press the VCR/TV mode select button to turn the VCR indicator on and off.)
TV	VCR	CABLE BOX		
Watch Cable Channels on TV	Select Cable box output Channel			OFF (TV mode)
Select and Watch Channels using VCR	AUX or VIDEO	Select Cable box output Channel	Select Channel to Watch	
Record and Watch the Same Channel	AUX or VIDEO	Select Cable box output Channel	Select Channel to Watch	
Record One Channel Watch Another	Select Channel to Watch	Select Cable box output Channel	Select Channel to Record	OFF (TV mode)
Watch Playback of a Tape	AUX or VIDEO			

SETTING THE CLOCK - AUTOMATIC MODE

Note: An antenna or cable must be connected to the VCR before you begin this operation.

Tips

You'll need to set the clock when first hooking up your VCR, and any time the power goes out for more than 1 hour. When you first plug in the VCR or after a power outage, the clock display will read "--:--".

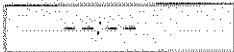
**Auto clock set function**

This function sets the VCR's clock automatically when the VCR is tuned to a station which transmits a time signal together with TV programs.

It also automatically sets the time differences between various time zones and sets the time during Daylight Saving Time (D.S.T). The auto clock set function operates each time the VCR is turned off.

- Some broadcast stations may not transmit a time signal. The auto clock set function does not operate when the VCR is tuned to a station which does not transmit a time signal. In this case, set the clock manually (See page 20).
- When the clock is set automatically, the displayed time may drift from the current time by up to one minute.

Setting the clock automatically - if your VCR's hooked up to an antenna or cable without a cable box (Hookups [A], [B], [C] or [D])

1 Press the POWER button to turn the VCR power off.

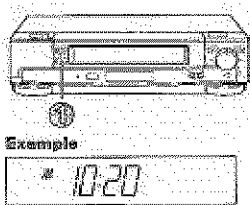

If the VCR is already turned off, press the POWER button to turn the power on, then press it again to turn the power off. The time will appear in the VCR display to show that the current time has been set. The automatic clock set procedure might take about 5 minutes.

Notes:

- If the clock is not set after about five minutes have elapsed, the clock must be set manually (see page 20).
- When the VCR power is restored after a power failure of more than one hour, the clock will indicate "--:--", and the clock set procedure (automatic or manual) must be repeated.
- If the time displayed on the VCR drifts from the current time by more than one hour, select your correct time zone and set the DST (Daylight Savings Time) (see page 19).

SETTING THE CLOCK -AUTOMATIC MODE WITH CABLE BOX

If your VCR is hooked up to a cable box (Hookups [E], [F] or [G])

Note: Turn on the cable box before setting.

1 Turn on the TV and select the video channel (3 or 4).

Or, if you are hooked up with an audio/video cable, set the TV to AUX or VIDEO.

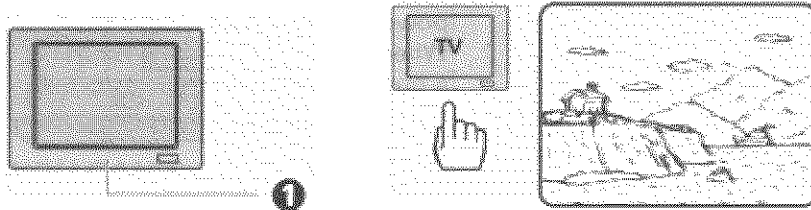

2 Press the GUIDE button.

The main on-screen menu will appear on the TV screen.

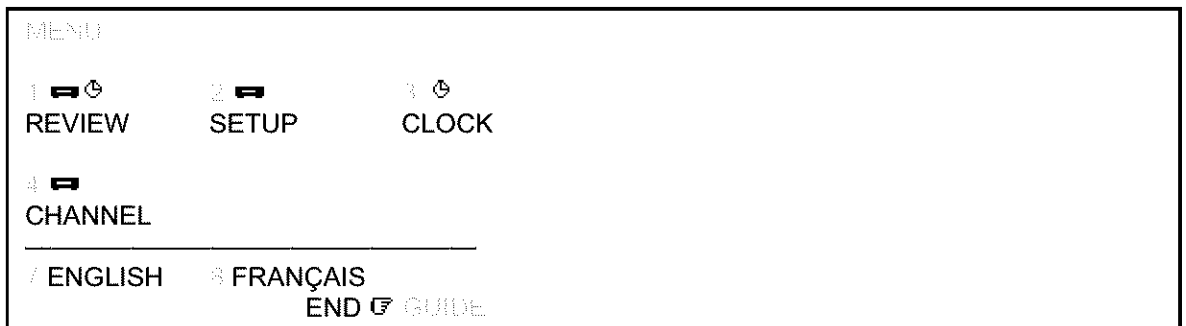

You may view all the on-screen instructions in English or French. When you first set up your VCR, it will be set to English. Press the (8) button for French.

3 Press the (3) button to bring up the CLOCK SET menu.

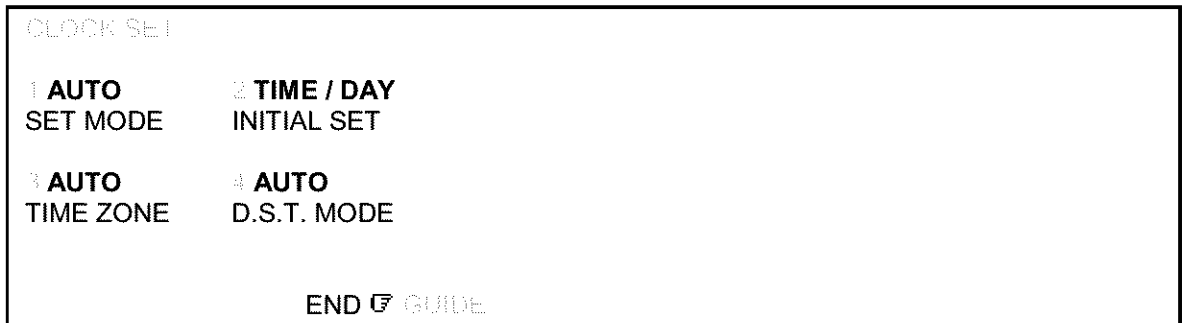

4 Make sure that item 1 is highlighted SET MODE "AUTO".

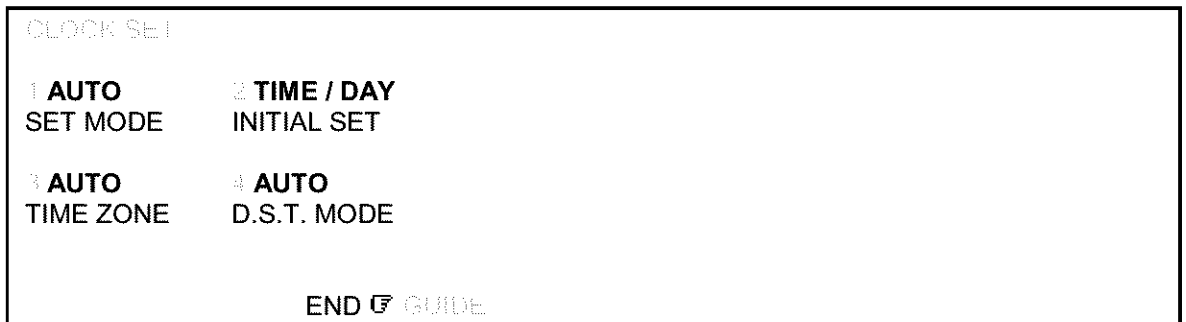

- If SET MODE "MANUAL" is highlighted, press the (1) button to switch it to SET MODE "AUTO".

5 Press the (2) button.

This screen appears to show that the clock is being set.

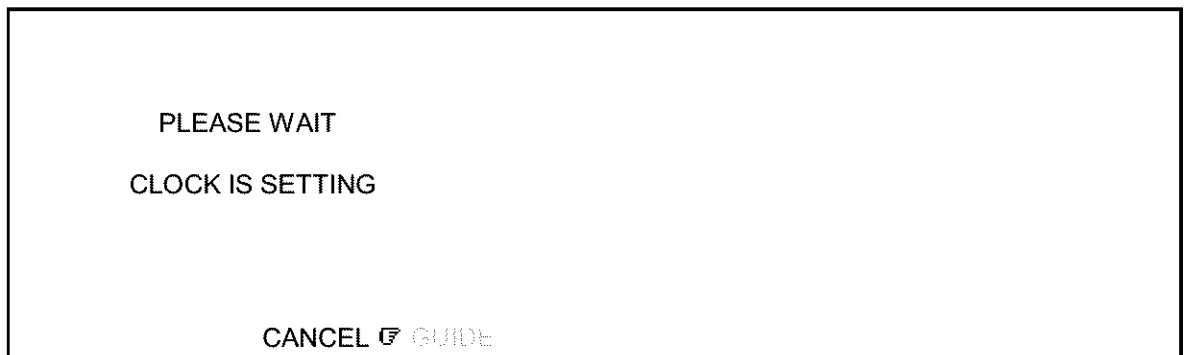

- It may take about five minutes.
- Since the VCR is searching for a broadcast station that transmits a time signal, the channel indication on the cable box changes automatically.

When the clock is set, the screen changes to a TV picture and the correct time appears in the VCR's display.



Notes:

- If the clock is not set after five minutes have elapsed, set the clock manually (see page 20).
- If the displayed time drifts from the current time by more than one hour, select your correct time zone and set the DST (see page 19).

SETTING THE CLOCK - TIME ZONE SETTING/DAYLIGHT SAVING TIME SETTING

What to do if the displayed time drifts from the current time by more than an hour

Note: Turn on the cable box with hookups [E], [F] or [G] before setting.

1 Press the **GUIDE** button.

The main on-screen menu will appear on the TV screen.

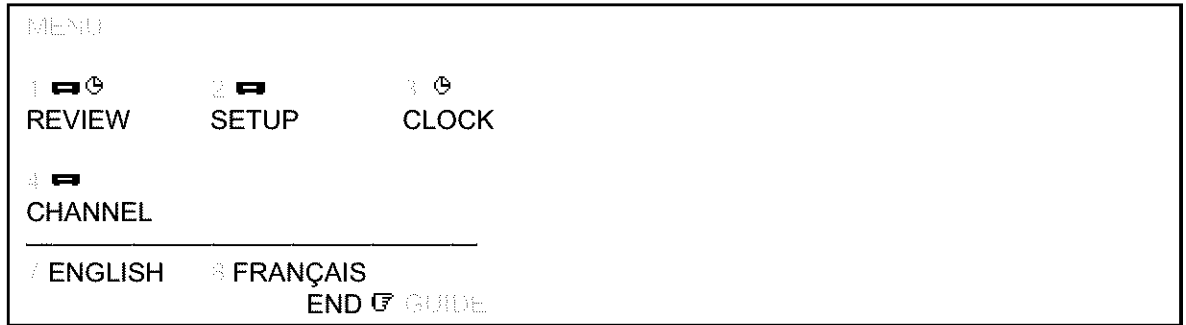

2 Press the **(3)** button to bring up the **CLOCK SET** menu.

Make sure that item 1 is highlighted SET MODE "AUTO".



3 Press the **(3)** button to select your local time zone.

Each time (3) is pressed, the option for "TIME ZONE" switches from "AUTO" to "ATLANTIC", "EASTERN", "CENTRAL", "MOUNTAIN", "PACIFIC", "ALASKA", "HAWAII" and back to "AUTO".

• This screen gives an example where "ATLANTIC" is specified.

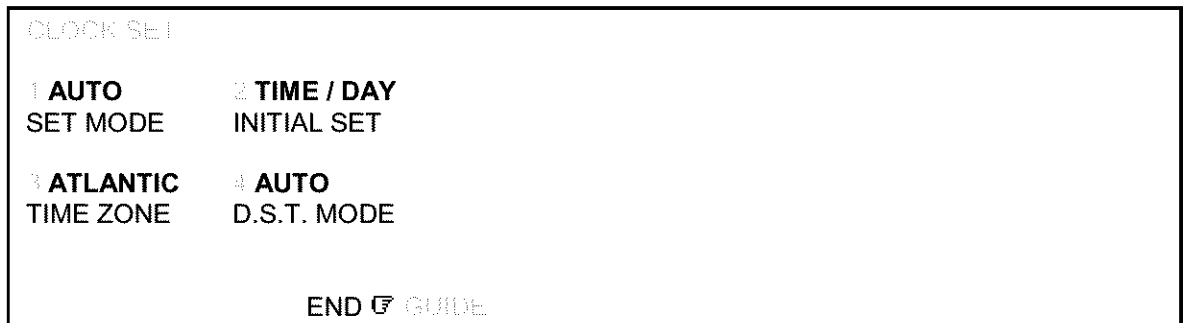

4 Press the **(4)** button to select the **D.S.T.** option.

Each time (4) is pressed, the option for D.S.T. MODE switches from "AUTO" to "ON", "OFF" and back to "AUTO".

AUTO: The daylight saving time (D.S.T) is set automatically.

ON: The time advanced from the Standard Time by one hour is displayed from the first Sunday of April through the last Sunday of October.

OFF: The standard time is displayed throughout the year.

• This screen gives an example where "ON" is specified.



5 Press the (2) button to set the time.
This screen appears to show that the clock is being set.

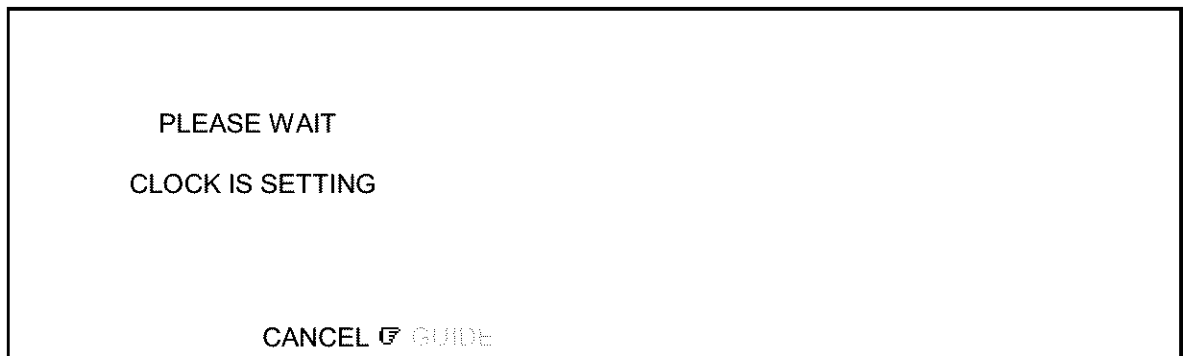

Note: If the displayed time drifts from the current time even after steps 1 - 5 have been performed, reset the DST. Press the GUIDE and (3) buttons then press the (4) button to specify another option, then set the time again.

SETTING THE CLOCK -MANUALLY**To set the clock manually****1 Press the GUIDE button.**

The main on-screen menu will appear on the TV screen.

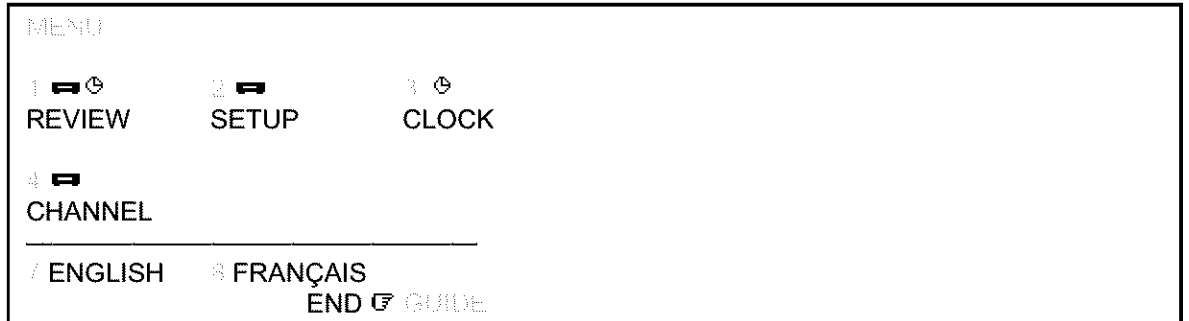

You may view all the on-screen instructions in English or French. When you first set up your VCR, it will be set to English. Press the (8) button for French.

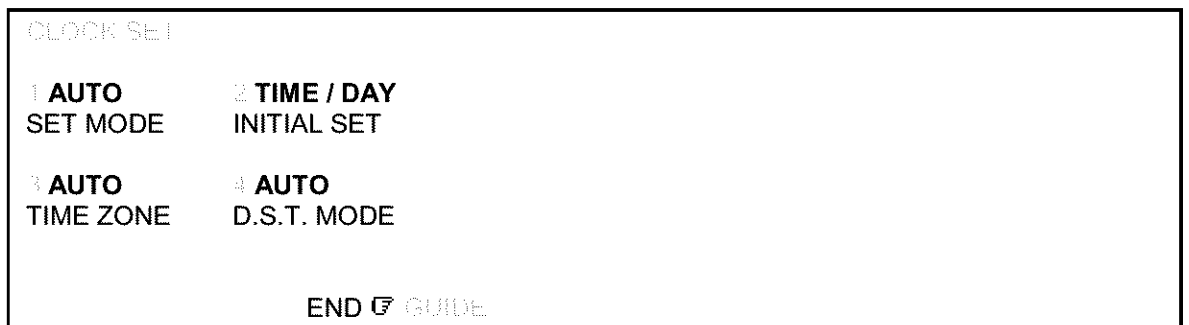
2 Press the (3) button to bring up the CLOCK SET menu.**3 Press the (1) button to select SET MODE "MANUAL".**

When SET MODE "MANUAL" is selected, TIME ZONE (item 3) and DST MODE (item 4) are not displayed.

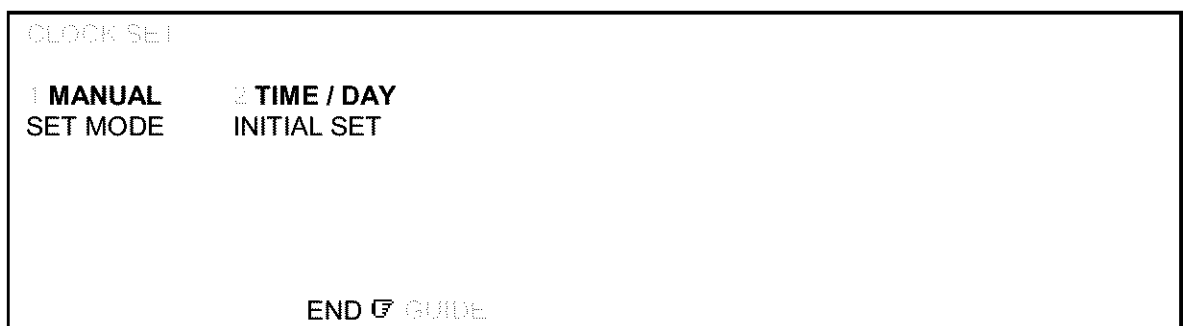
**4 Press the (2) button to bring up the clock set menu.**

• The white dash "-" appears for the item to be changed on the screen as you proceed.



END  GUIDE

5 Press the number buttons to fill the hour and minutes.



- For times with only one number (1-9) press the (0) button first, then the hour or minute. For example, if it is now 10:20AM, press (1)(0)(2)(0). "AM" and "PM" will now appear on the screen.

Example

CLOCK SET

TIME

10 : 20

AM  1 PM  2

MONTH/DAY/YEAR

--/--/--

END  GUIDE

6 Press the (1) button for AM or (2) for PM.

For example, press the (1) button for AM.

CLOCK SET

TIME

10 : 20 AM

MONTH/DAY/YEAR

--/--/--

END  GUIDE

7 Press the number buttons to fill in the number of the month, then the day then the year.

- For dates with only one number (1-9) press the (0) button first, then the date.
- For example, if today is July 8 1999, press (0)(7)(0)(8)(9)(9). The correct day of the week will appear by itself.

CLOCK SET

TIME

10 : 20 AM

MONTH/DAY/YEAR

07 / 08 / 99 THU

END  GUIDE

8 Press the GUIDE button.

The VCR clock is now set, and should show the correct time of day on the VCR's display.

Example



Notes:

- The clock uses the 12-hour system. You set it for AM or PM.

- An illogical time (like 13 for the hour or 20 for the month) will not be accepted.
- If you press the wrong digit, exit the screen by pressing GUIDE and recall the screen to enter the correct setup.

PRE-TUNING THE VCR TUNER

Note: An antenna or cable must be connected to the VCR before you begin this operation.

Presetting the received channels without using a cable box (Hookups [A], [B], [C] or [D])

1 Press the **POWER** button to turn on the VCR.

2 Turn on the TV and select the video channel (3 or 4).

Or, if you are hooked up with an audio/video cable, set the TV to AUX or VIDEO.

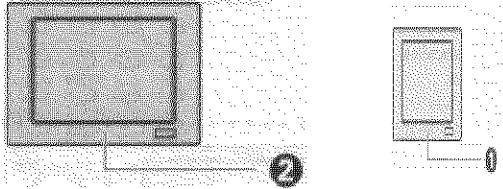

3 Press the **GUIDE** button.

The main on-screen menu will appear on the TV screen.

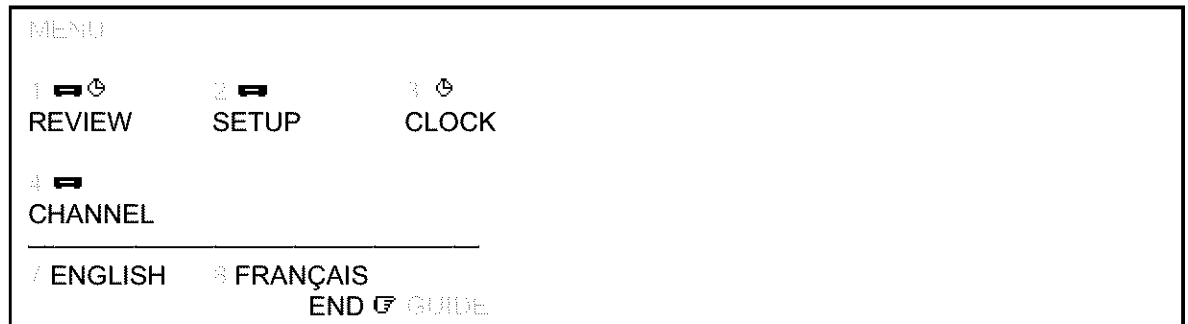

4 Press the **(4)** button to select the **CHANNEL PRESET** operation.

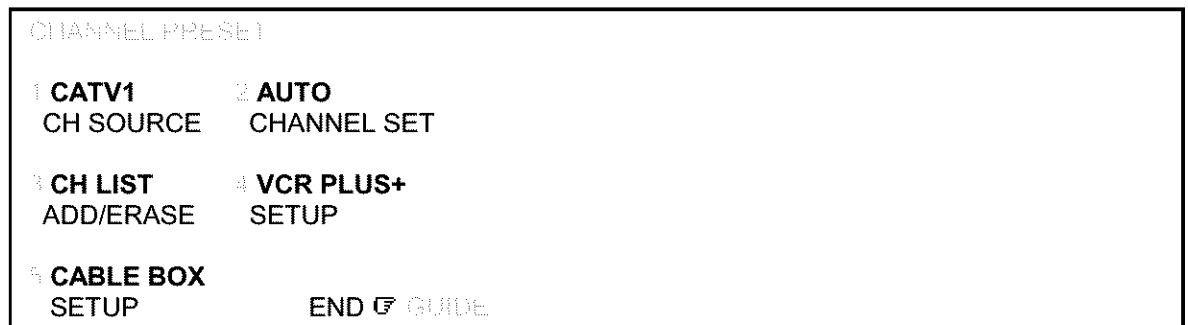

5 Press the **(1)** button to select the type of receiving setup you have:

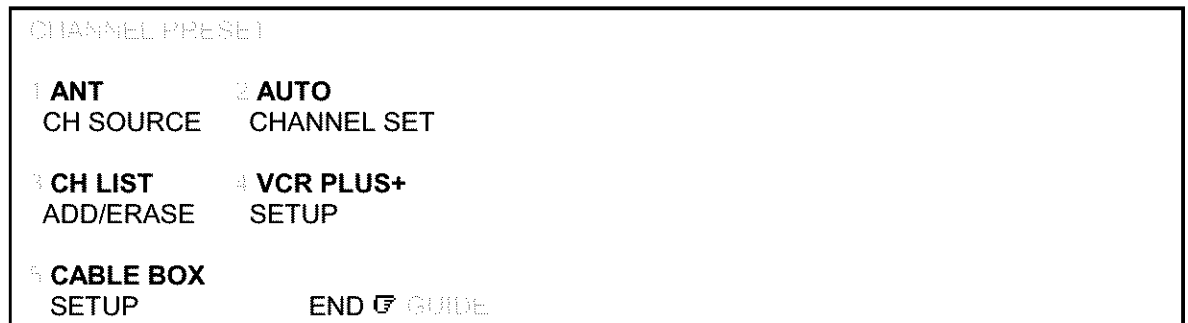

ANT: Internal or external antenna

CATV1: Ordinary cable

CATV2: Alternate cable (If CATV1 doesn't give you the channels you expect).

6 Press the (2) button.

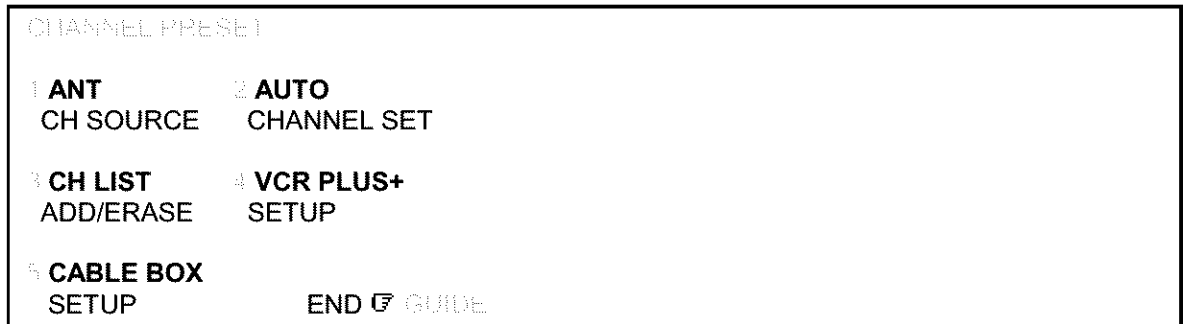

The VCR will automatically store channels received in your area. It takes about 2 - 3 minutes. After the channels are stored in memory, the channel with the lowest number appears in the VCR's display.

7 Press GUIDE to return to regular viewing.

Note: Your VCR is capable of receiving 68 broadcast TV channels (VHF 2 – 13, UHF 14 – 69) and cable channels (CATV 1 – 125). In some areas channels cannot be received when CATV1 is selected. In this case, select CATV2 in the receiving setup.

When automatic presetting of channels are finished

Press the CH (channel) button (or numbered buttons) to check the channels you can receive.



Note: If no channels have been set or a clear picture does not appear, check the antenna or cable connection

To add or erase channels

The auto channel set procedure may memorize channels that are blank, have snowy pictures, or interference. You may skip these channels by erasing them. Very weak stations might not be memorized at all. You may receive these stations by adding them.

1 Press the GUIDE button.

The main on-screen menu will appear on the TV screen.

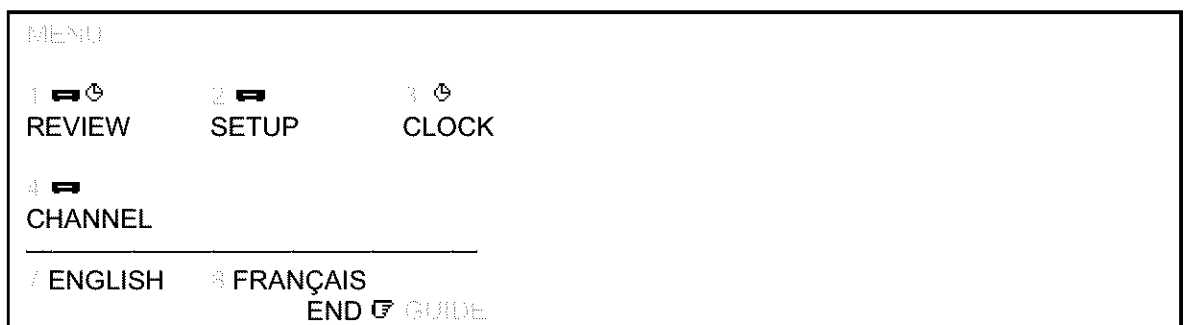

2 Press the (4) button to select the CHANNEL PRESET operation.

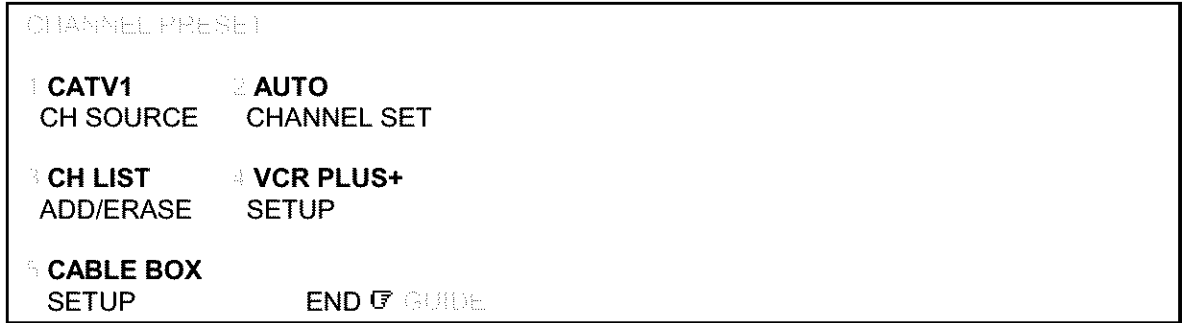

3 Press the (3) button to select ADD/ERASE CHANNEL.

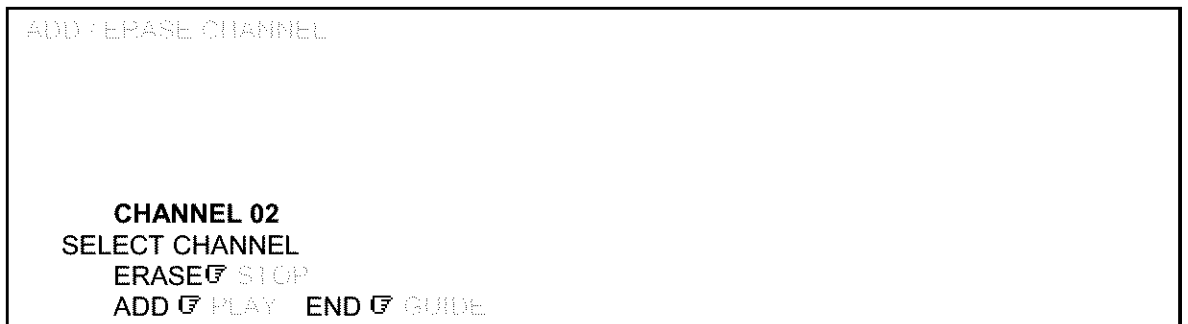

4 Use the number buttons to select the number of the channel you want to add or erase.

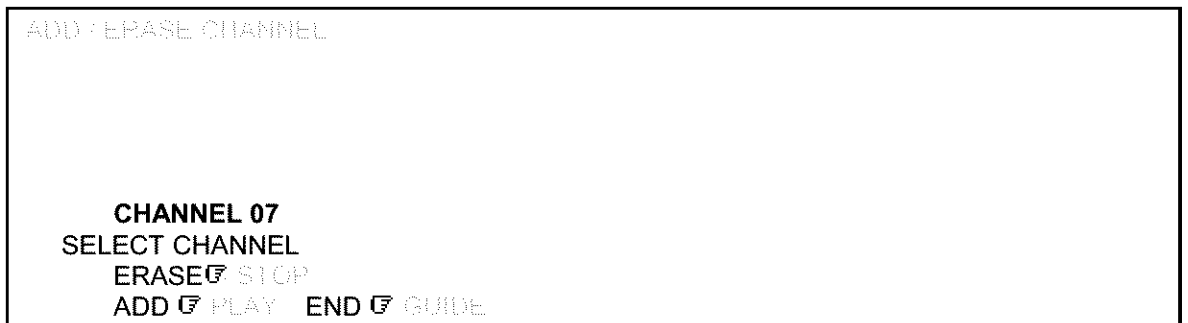

5 Press the STOP button to delete the channel, or press the PLAY button to add it.

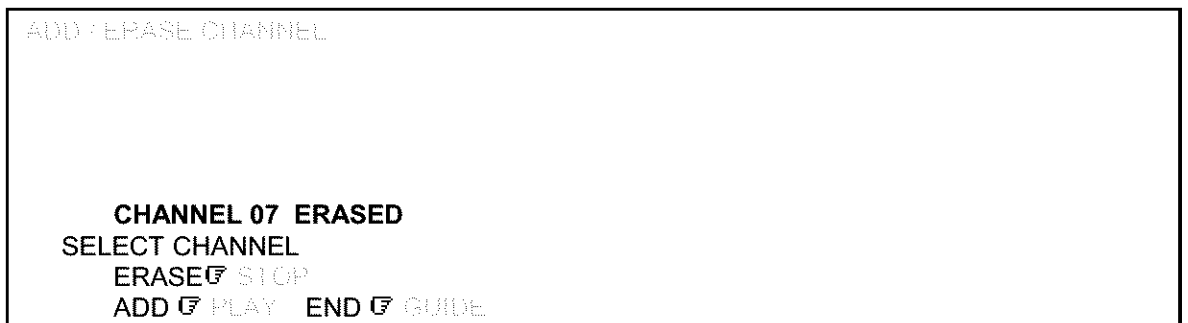

6 Press the GUIDE button to return to regular viewing.

Auto blue setting

1 Turn on the TV and select the video channel (3 or 4).

Or, if you are hooked up with an audio/video cable, set the TV to AUX or VIDEO.

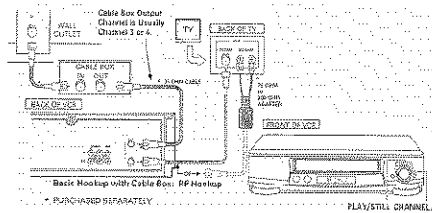
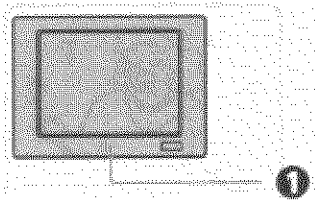

2 Press the GUIDE button.

The main on-screen menu will appear on the TV screen.



3 Press the (2) button to select VCR SETUP.



4 Press the (1) button to select AUTO BLUE "ON" or "OFF".



ON: The screen becomes blue and mutes sound when a channel without a broadcast signal on the VCR or a channel on which broadcasting has finished.

- If the signal is too strong, this function may not operate even if you specify "ON". During playback this function does not operate.

OFF: The AUTO BLUE feature is switched off.

5 Press the GUIDE button to end the setting.

CABLE BOX SETUP

Note: This setup should be performed if you receive all channels through a cable box. (Hookups [E], [F] or [G]).

The VCR can be programmed to:

- Automatically select channels on the cable box during a timer record or VCR Plus+ delayed recording operation.
- Change channels on remote controlled cable boxes with the VCR remote control.

BEFORE YOU BEGIN...

Make sure the cable box is positioned properly on the VCR.

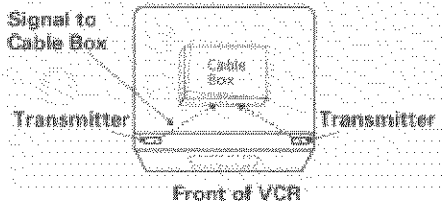

1 Turn on the TV and select the video channel (3 or 4).

Or, if you are hooked up with an audio/video cable, set the TV to AUX or VIDEO.

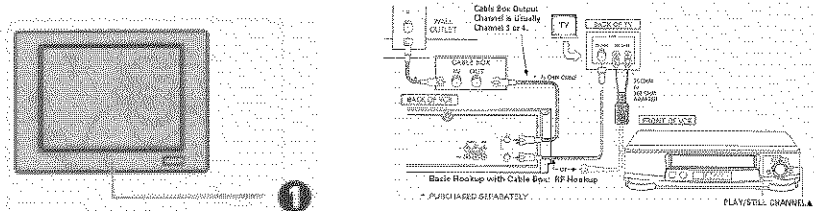

2 Press the GUIDE button.

The main on-screen menu will appear on the TV screen.

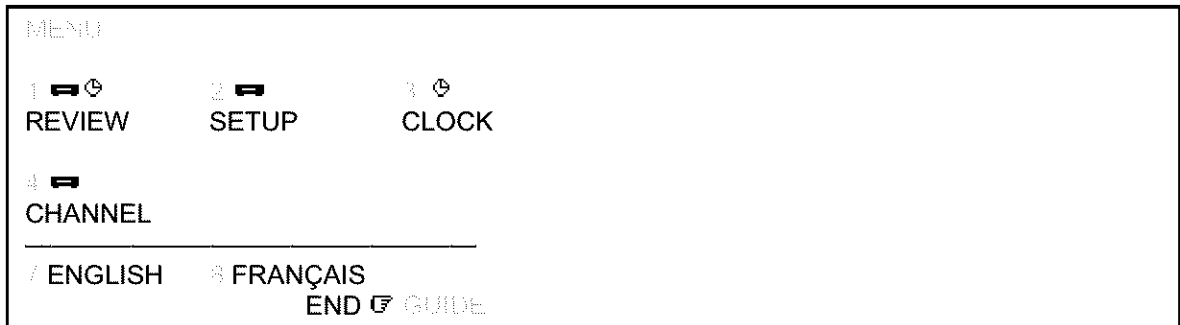

3 Press the (4) button twice to select the CHANNEL PRESET operation.

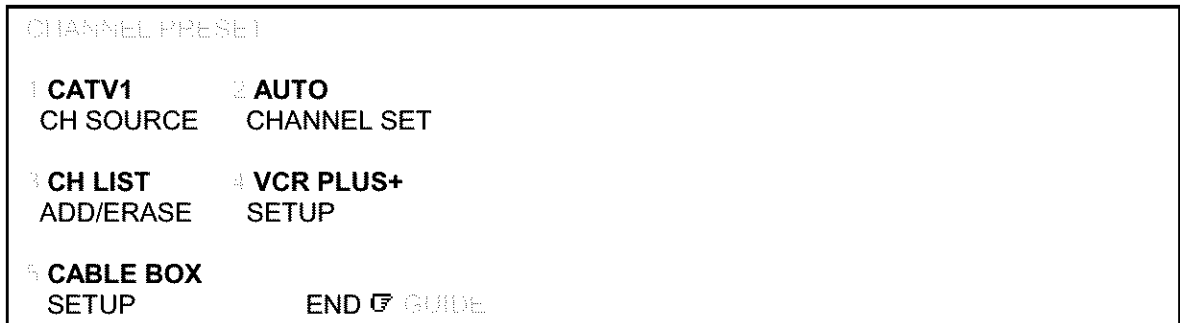

4 Press the (1) button twice to select "CATV2".



1 CATV2 CH SOURCE	2 AUTO CHANNEL SET
3 CH LIST ADD/ERASE	4 VCR PLUS+ SETUP
5 CABLE BOX SETUP	END GUIDE

5 Press the (5) button to select **CABLE BOX SETUP** menu.

CABLE BOX SETUP

IS CABLE BOX BEING USED?

YES 1

NO 2

6 Press the (1) button to answer "YES" to the question "IS CABLE BOX BEING USED?"

CABLE BOX SETUP

TURN ON CABLE BOX AND
TUNE IT TO CH 02

OUTPUT CH -

END GUIDE

7 Turn on your cable box and select channel 2.

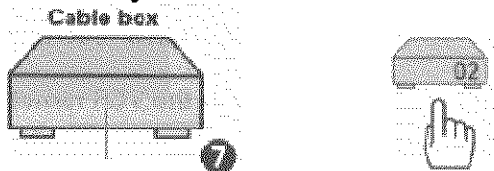

8 Using the VCR remote, enter the cable box output channel numbers.

For example, press (0)(3) for channel 3.

CABLE BOX SETUP

TURN ON CABLE BOX AND
TUNE IT TO CH 02

OUTPUT CH 03

PROCEED GUIDE

9 Press the **GUIDE** button to enter the output channel of your cable box.

• The **CABLE BOX TYPE** message will appear on the TV screen.

CABLE BOX SETUP

OUTPUT CH 03
 CABLE BOX TYPE -
 ENTER CABLE BOX TYPE
 FROM OWNER'S MANUAL

END  GUIDE

10 Press the two number buttons that match the code number of your cable box brand from the table below.

For example, press (3)(7) for the Hitachi brand cable box.

CABLE BOX SETUP

OUTPUT CH 03
 CABLE BOX TYPE 37
 ENTER CABLE BOX TYPE
 FROM OWNER'S MANUAL

PROCEED  GUIDE

Brand	Code Number(s)	Brand	Code Number(s)
Anvision	07, 08	Randtek	07, 08
Cablestar	07, 08	RCA	00, 27, 39, 44
Eagle	07, 08, 19, 26, 28, 32, 40, 41, 60	Regal	12, 13, 19, 40, 58
Eastern International	02	Regency	02, 33
GE	56	Rembrandt	53
General Instrument	04, 05, 15, 23, 24, 25, 30, 36, 55, 61	Samsung	15, 18, 27, 36, 39, 44, 53
Hamlin	12, 13, 34, 48, 58	Scientific Atlanta	03, 22, 35
Hitachi	37, 43	SL Marx	15, 18, 31, 36, 44, 53
Jerrold	04, 05, 15, 23, 24, 25, 30, 36, 45, 46, 47, 55, 61	Stargate	15, 18, 31, 36, 44, 53
Macom	37, 43	Sylvania	11
Magnavox	07, 8, 19, 26, 28, 29, 32, 33, 40, 41	Teknika	06
Movietime	09, 59	Teleview	15, 18, 36, 44, 53, 59
GC Electronics	31, 53	Texscan	10, 11
NSC	09, 59	Tocom	17, 21, 49, 50, 54, 57, 61
Oak	01, 16, 28, 38	Unika	31, 32, 41, 53
Oak Sigma	16	Universal	51, 52
Panasonic	03, 27, 39, 44	Viewstar	07, 08, 19, 26, 28, 29, 32, 33, 40, 41, 59, 60
Philips	07, 08, 19, 26, 28, 29, 32, 33, 40, 41	Warner Amex	44
Pioneer	18, 20, 44	Zenith	14, 42
Puiser	31, 53		

11 Press the GUIDE button to enter your cable box brand.

The VCR will change the cable box from channel 02 to channel 09 to confirm that the correct code was entered.

CABLE BOX SETUP

OUTPUT CH 03
 CABLE BOX TYPE 37
 DID CABLE BOX TUNE TO
 CH 09

YES 1
NO 2
END GUIDE

12 Cable box channel changed to channel 9: Press the (1) button to end this setting.

Your cable box and VCR are now set for VCR Plus+ program recording. Depending on the manufacturer and model of the cable box, you may also be able to use the VCR remote control to:

- Change channels on the cable box with the remote's channel Up/Down buttons.
- Use the numbers on the VCR remote to select cable box channels directly.

Note: Only the cable box will change channels. The VCR channel will not change.

Cable box did not tune to channel 9: Press the (2) button to return to step 10, and enter a different code number.

CABLE BOX SETUP

OUTPUT CH 03
CABLE BOX TYPE 37
ENTER CABLE BOX TYPE
FROM OWNER'S MANUAL

END GUIDE

If the codes you entered do not work:

- Try repositioning the cable box on top of the VCR and reentering the codes.
- Try entering all code numbers (00 - 61). Press the number button to enter another code number.

If none of the codes work, press the GUIDE button to quit. The VCR will not control your cable box. However, the output channel of the cable box has been set. Turn on the cable box and leave it tuned to the channel you want to record before the recording is scheduled to begin.

Note: If you make a mistake when entering digits, press the CLEAR button repeatedly to return the white dash "-" to the digit to be corrected. Then, punch in the correct number.

PLAYBACK**To playback a recorded tape**

1 Turn on the TV and select the video channel (3 or 4).

Or, if you are hooked up with an audio/video cable, set the TV to AUX or VIDEO.

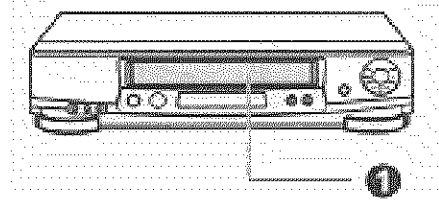
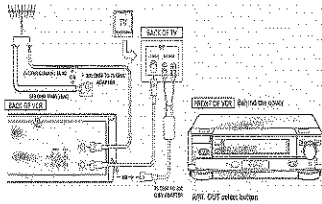

2 Insert a recorded tape.

The power comes on automatically and the tape indicator lights on the display.

- When a cassette without its safety tab is inserted, playback starts automatically.

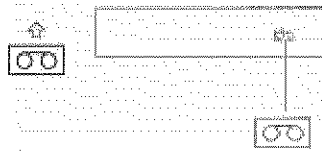

3 Press the PLAY button to start playing the tape.

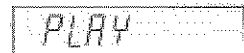

4 Press the STOP button to end playback.

Note: This VCR can quasi playback the tape that is recorded by S-VHS type. SQPB stand for S-VHS Quasi Playback.

When VCR playback by SQPB, the inversion noise will appears on screen in STILL, SLOW and F.ADV mode.

Rewinding the tape

When the video cassette reaches the end of the tape, the VCR will stop and automatically rewind the tape.

- If you press the POWER button while the tape is rewinding, the power will not shut off until the tape has been completely rewound.

You may also rewind the tape manually at any time.

Manual Rewind

1 Press the STOP button to end playback.

2 Press the REW button.

The VCR rewinds the tape all the way to the beginning, then stops.

- Press the EJECT button on the VCR to eject the tape.

**Rewinding the tape****Movie Return**

If your videocassette has the safety tab removed, the VCR will stop and automatically rewind the videocassette, eject it, and turn off the power when it reaches the end of the tape or a blank section of tape which lasts for more than 30 seconds.

Note: This function works only in PLAYBACK mode, not in RECORDING mode.

To remove noise from the picture

Auto Tracking

Pressing the PLAY button starts the auto tracking feature, which automatically adjusts playback to eliminate static lines or picture noise that may appear on the screen.

Manual Tracking

Scratched tapes or poorly recorded tapes may require additional picture adjustment. You can do this with the remote control.

Note: To reactivate auto tracking, simply eject the tape and reinsert it into the VCR.

1 Press the TRACKING button when viewing a cassette.

Press either the + or - buttons until picture is clear.



- If you press the AUTO TRACKING button after adjusting the playback picture with the TRACKING button (+ or -), auto tracking will operate again.

Note: To reactivate auto tracking, simply eject the tape and reinsert it into the VCR.

Rewinding or fast forwarding a tape at high speed

This function rewinds or fast-forwards T-120 tape for about 83 seconds. This time period will vary for different types of tapes.

Press the REW or F.FWD button, then press it again.



To stop the tape, press the STOP button.

Note: During super rewind/fast-forward, there will be an interval of 5 seconds between the time the stop button is pressed and the tape actually stops. This is designed to protect the tape. To stop the tape earlier, press the REW or F.FWD button to restore the normal rewind/fast forward speed, then press the stop button.

SPECIAL PLAYBACK EFFECTS**Variable speed playback****Still Playback (Pause)**

Press the **PAUSE** button on the remote control or **PLAY/STILL** on the VCR to still the tape during play.



The picture will "freeze". You may see some minor noise or interference on the screen. This is normal.

- To resume play, press the **PLAY** button or **PAUSE (PLAY/STILL)** button again.

Note: The sound is muted and cannot be heard during "Special Playback Effects".

Notes:

- After 1 minute in the **PAUSE** mode, the VCR automatically switches to **STOP** mode to protect the tape.
- If noise bars appear on the TV screen during the **PAUSE** mode, first set the VCR to the **SLOW** mode by pressing the **SLOW** button during playback and then press the **TRACKING** (▲ or □) button on the remote control to minimize the noise bars (see page 31).
- If the screen jitters during **PAUSE**, press the **TRACKING** (▲ or □) button to minimize the jitter.

Frame Advance

1 Press the **PAUSE** button to stop the tape during playback.

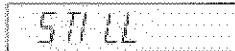

2 Press the **SKIP** button to view the picture one frame at a time.

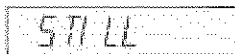

- Press the **PAUSE** button to resume play.

Skip Playback

While playing back your tape you can skip forward by pressing the **SKIP** button. The tape will search ahead for about a minute and then resume playing.

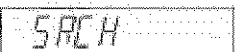
**Slow Motion**

1 Press the **PLAY** button.



2 Press the **SLOW** button to slow the playback speed.

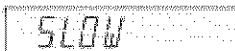

3 Press the **PLAY** button to return to play back at a normal speed.
Press the **STOP** button to stop the tape.

Notes:

- Use the **TRACKING** (+ or -) button to minimize any visual noise bands on the screen.
- After 1 minute in slow motion playback, the VCR will stop the tape automatically to prevent damage to the tape.

and VCR.

Visual Search

This function let you search backward and forward through the videotape while viewing it.

During play:

Press the REW button to search in reverse.

Press the F.FWD button to search ahead.



- Press the PLAY button to return to normal playback.

Press REW or F.FWD and hold it; you can search backward or forward through the tape at a higher speed while viewing it.

- Press PLAY and REW, then hold REW for backward search at a higher speed.
- Press PLAY and F.FWD, then hold F.FWD for forward search at a higher speed.
- Release REW or F.FWD to return to normal playback.

Choosing a mode for audio playback

The VCR records the same audio on both the Hi-Fi and linear tracks on the tape. The Hi-Fi sound is recorded on separate left and right stereo channels. Monaural sound is recorded on the linear track.

To enjoy Hi-Fi sound, connect your VCR to a stereo television or amplifier/receiver using the audio/video jacks (see page 56).

How to select playback audio

1 Press the GUIDE button.

2 Press the (2) button to select the VCR SETUP operation.





3 Press the (2) button to select "HIFI" or "LINEAR".

- Select **Hi-Fi** to playback sound recorded on the Hi-Fi track and for normal use.

The L and R indicators will light in the VCR's display panel.

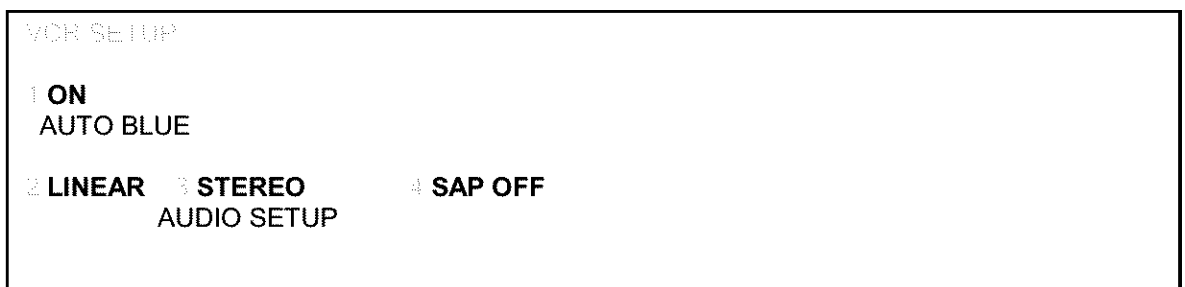
- Select **LINEAR** to play back the sound recorded on the linear monaural track. Also, if the audio sounds distorted or unusual or there is no audio, select LINEAR.



END  GUIDE

4 Press the GUIDE button to end the setting.

MOVIE  ADVANCE™ (MA SKIP)

"MOVIE ADVANCE™ is a trademark of SRT, Inc.

A Jerry Iggulden invention licensed in association with Arthur D. Little Enterprises, Inc."

MOVIE ADVANCE™ locates the start of a movie on rented tape, etc., by automatically skipping commercials, logo marks, previews, information on copyrights, etc. You can also locate the start of previews.

Notes:

- MOVIE ADVANCE™ can be operated only with cassette recorded in the SP mode and the safety tab removed.
- MOVIE ADVANCE™ will not operate with damaged tapes.
- The VCR may not be able to locate the starts of specific movies or previews.

Locating the start of movie

1 Turn on the TV and select the video channel (3 or 4).

Or, if you are hooked up with an audio/video cable, set the TV to AUX or VIDEO.

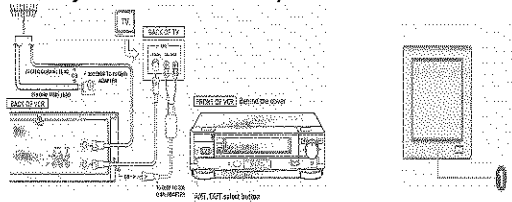

2 Insert a recorded tape.

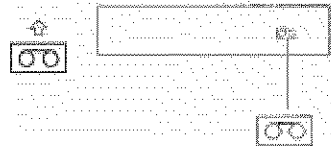

- The power comes on automatically and the tape indicator lights on the display.
- Playback starts automatically.
- If you have inserted a tape which was played part way, rewind the tape to its start, and then press the PLAY button.

3 Press the MA SKIP button.

The "MOVIE ADVANCE" menu will appear on the TV screen.

MOVIE ADVANCE

PLEASE SELECT

GO TO START OF MOVIE  1

GO TO FIRST PREVIEW  2

END  MA SKIP

4 Press the (1) button to select "GO TO START OF MOVIE".

- The tape is fast forwarded.

It may take several minutes to find the start of any designated movie.

GO TO FIRST PREVIEW  2

END  MA SKIP

4 Press the (2) button to select "GO TO FIRST PREVIEW".

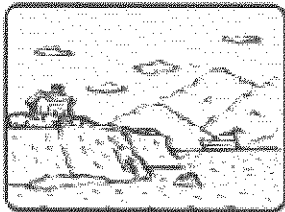

- The tape is fast forwarded, and a preview will play automatically.
- If you press the MA SKIP button while viewing the preview, the tape is fast forwarded, and the next preview will play automatically.

SHUTTLE CONTROL

Using the shuttle ring on the remote control

The shuttle feature lets you control all the playback functions – PLAY, PAUSE, SLOW MOTION, and SEARCH – using one convenient ring.

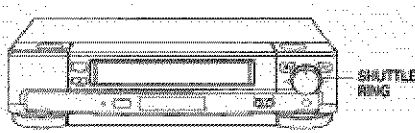

How to use the shuttle ring

[A] Turn the shuttle ring during playback or still playback (pause).

- As you turn the ring, you get different playback speeds and forward or reverse motion.
- Try using the shuttle to explore backward and forward through your next video.

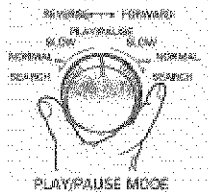

[B] Turn the ring in the stop mode to fast forward or rewind the tape.

- The tape continues to be wound even after you release the dial.

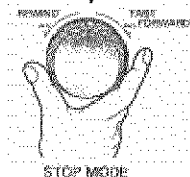

Notes:

- If noise bars appear on the TV screen during the **SLOW/STILL** modes, turn and hold the shuttle ring in the **SLOW** position, then press the TRACKING (+ or -) button on the remote control to minimize the noise bars. The noise bars are then eliminated automatically in the **STILL** mode.
- Since thin videotape is used in T-180 and longer cassettes, do not repeatedly perform the following operations with these tapes.
 - Fast forward, rewind, slow play
 - Insertion and ejection of tapes

USING THE "INDEX" FEATURE**To find specific sections on a tape using the "INDEX" feature****Jump to an Index Mark with INDEX**

A quick way to access specific program segments is with the index search feature. This lets you move through a tape that has several recordings on it by searching for the INDEX "mark". This function only works with recordings that have been set up with indexing. You create an INDEX mark (VISS signal) every time you press the REC or REC/IRT button while recording.

1 Press the DISPLAY button in the stop mode.

The index screen appears on TV.

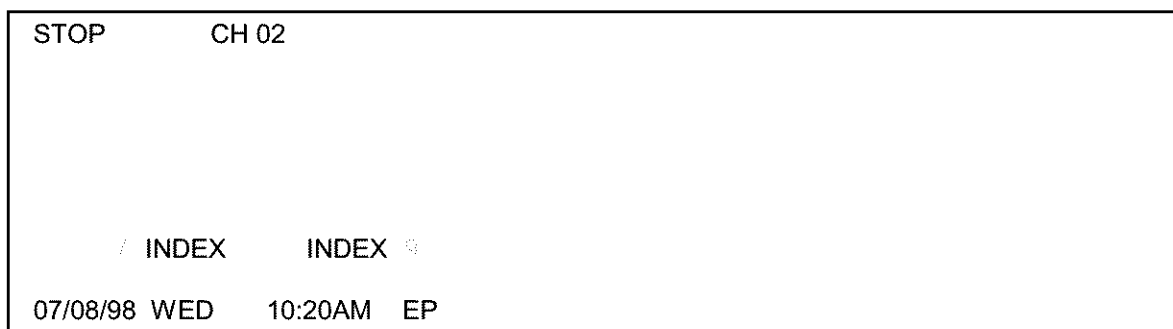
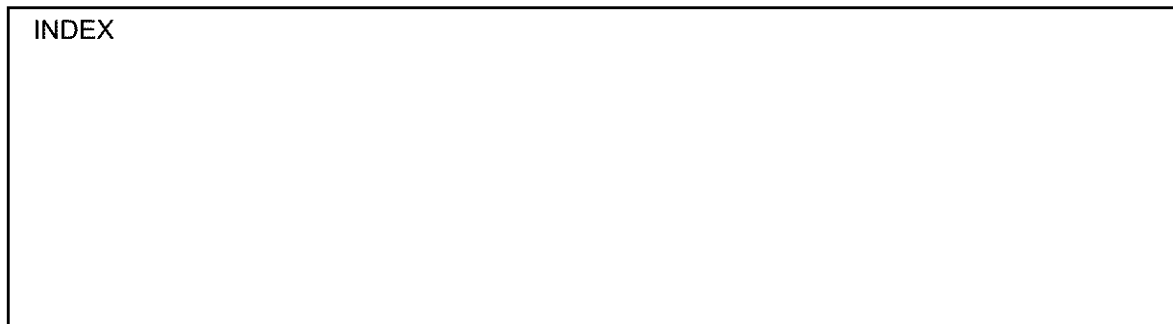
**2 Press the (7) button for rewind or the (9) button for forward to begin the index search.**

- The tape rewinds or fast forwards until an index mark is detected. During this search, the word INDEX is displayed at the top left corner of the screen.
- When the VCR finds an index mark, it plays 15 seconds of the program that begins at that spot.

3 If this is the program you were looking for, press the PLAY button for normal playback.

- To stop the index search before an index mark is reached, press the STOP button.

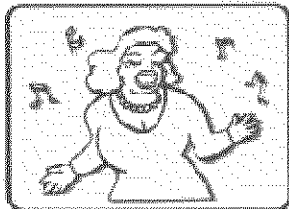

Note: If there are no index marks on the tape, the VCR will just rewind to the beginning or fast forward to the end.

VIEWING THE ON-SCREEN DISPLAY**Switching between the clock, time counter and time of remaining tape**

Press the DISPLAY button while the on-screen display is displayed. The on-screen display switches in the order below together with the VCR's display.

On-Screen and VCR Displays Illustration

Press the DISPLAY button to see the clock.

Press the DISPLAY button a second time to see just the time counter.

Notes:

- The linear time counter operates only if there is something recorded on the tape.
- The counter changes to 0:00:00 when the tape is ejected.

Press the DISPLAY button a third time to see the tape remaining time.

Note: Immediately after the tape is inserted, "-- : --" will appear.
2 minutes after playback or recording is started, the tape remaining time is displayed.

Press the CLEAR button repeatedly to switch the type of the tape used. The correct remaining time will appear.

AUTO: T-120 or shorter tape
T-160: T-140 or T-160 tape
T-180: T-180 tape
T-210: T-210 tape

Notes:

- The tape remaining time is not displayed correctly for a tape without any recordings or tapes other than T-30/60/90/120/140/160/180/210.
- The remaining time may not be displayed correctly during fast forwarding or rewinding.

INDEX WITH THE TIME COUNTER**To find specific sections on a tape****Indexing with the Time Counter**

You can set the time counter to memorize a certain point in the video programming, and you can return to that point automatically.

1 Press the DISPLAY button two or three times.

The counter will appear in the VCR's display.

**2 Begin recording or playing back a tape.****3 At the point that you want to go back to, press the CLEAR button.**

This resets the counter to 0:00:00.

**4 Press the STOP button when you are done recording or playing back the tape.****5 Press the REW button to rewind the tape.**

It will automatically stop at the spot where you cleared the counter in step 3.

- Press the PLAY button to watch the tape from the selected spot.

Note: Press the DISPLAY button to turn the counter display off. The selected spot will stay in memory until you set a new one or until the tape is ejected.

RECORDING A PROGRAM

Before you record

Note: The cassette safety tab must be in place in order to record.
To re-record on a cassette which has its safety tab removed.

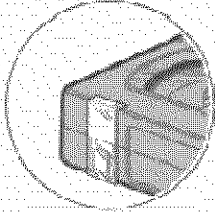

Cover the hole with cellophane tape.

The VCR must be hooked up properly for recording. See the Simple Hookups at the beginning of this manual.

Copyright infringement warning

Most television programs and films are copyrighted. This means that someone has legal rights governing the reproduction and distribution of this material. In certain circumstances, copyright law may apply to private in-home taping of copyrighted materials. In most cases, it is okay to record for personal use, as long as you do not sell the material. You must act responsibly in this area – check into the matter if you are unsure.

Basic recording steps

Note: You may use a blank tape or you may record over a previously recorded (erasable) tape.

1 Turn on the TV and select the video channel (3 or 4).

Or, if you are hooked up with an audio/video cable, set the TV to AUX or VIDEO.

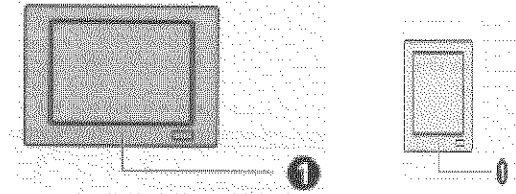

2 Insert a blank or erasable tape.

The power comes on automatically and the tape indicator lights on the display.

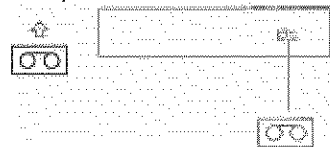

- If a cassette without its safety tab is inserted, playback starts automatically, and you cannot complete the record operation.

3 Press the TAPE SPEED button to select SP (standard play, for the best picture quality) or EP (extended play, for the longest recording time on a single tape).



- An indicator on the VCR's display shows which speed is selected.

4 Press the CH (▲ / □) button or the number buttons to select the channel you want to record.

Example: Select channel 8.





- 100/ENT and (2) and (4) for channel 124.

5 Press the REC button on the remote control or the REC/IRT button on the VCR.

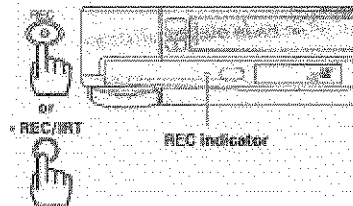

Recording will start and the REC indicator on the VCR will light red.

Notes:

- Recording will not start unless the cassette has the safety tab in place. If this tab has been removed, the VCR will eject the tape.
- Press the PAUSE button to set the VCR to the recording pause mode. Press the button again to re-start recording.
- If you stay in PAUSE mode for more than 5 minutes, the VCR automatically switches to STOP mode to protect the tape.

6 Press the STOP button to finish recording.

RECORDING A PROGRAM -RECORDING TIPS

To watch one program while recording another

1 Once you have set the VCR for recording, press the **VCR/TV** button.

The VCR indicator disappears. Now, you will be viewing through your TV only.



2 Switch channels using your TV controls or the VCR remote, if it's programmed to control your TV (see page 56).

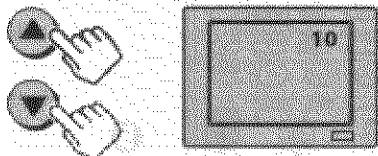

Notes:

- You can check on the recording by pressing **VCR/TV** again. This will switch you back to viewing through the VCR, and you'll see the program you are recording.
- **If you're hooked up with an audio/video cable:** Switch the TV from **AUX** or **VIDEO** mode back to the TV mode, then select the channels you want to watch, as described in Step 2. Switch TV back to **AUX** or **VIDEO** to monitor your recording.

To change the channel being recorded

1 Press the **PAUSE** button to stop the recording temporarily.



2 Press the **CH** (▲/□) button or number buttons to change the channel to the one you prefer.



3 Press the **PAUSE** button to continue recording.



Automatic Indexing

Your VCR will automatically create an invisible **"INDEX"** mark every time you press the **REC** button while recording. During playback, the Index Search feature will let you move through a tape that has several recordings on it by searching for the **"INDEX"** mark. See Page 36, **"Jump to an Index Mark with INDEX"**.

To record a Second Audio Program (SAP)

Some stations transmit a Second Audio Program – such as in a second language. If a station broadcasts in SAP, the SA indicator will display on your TV screen.

You can set the VCR to record a second audio program by activating the SAP option.

How to set the SAP option.

1 Press the **GUIDE** button.

2 Press the **(2)** button to select the **VCR SETUP** operation.

3 Press the **(4)** button to set the **SAP** option to **"ON"**.

```
VCR SETUP  
1 ON  
  AUTO BLUE  
  
2 HIFI   3 STEREO   4 SAP ON  
          AUDIO SETUP  
  
END [GUIDE]
```

4 Press the (3) button to set the STEREO/MONO option to "STEREO".

```
VCR SETUP  
1 ON  
  AUTO BLUE  
  
2 HIFI   3 STEREO   4 SAP ON  
          AUDIO SETUP  
  
END [GUIDE]
```

5 Press the GUIDE button to end the setting.

6 Follow the Step 1 through 5 on "Basic Recording Steps" on pages 39 and 40.

Stereo vs. mono sound

When you select the STEREO option in the initial setup operation, your VCR records in stereo any station that broadcasts stereo sounds. When a TV channel broadcasts in stereo, you'll see a stereo indicator on the TV screen.

Set to MONO if the stereo signal is weak and the sound is too "noisy".

```
VCR SETUP  
1 ON  
  AUTO BLUE  
  
2 HIFI   3 STEREO   4 SAP OFF  
          AUDIO SETUP  
  
END [GUIDE]
```

Note: When you select MONO, sound is recorded as mono even when a channel broadcasts in stereo.

INSTANT RECORDING TIMER

Using the Instant Recording Timer (IRT)

The Instant Recording Timer (REC/IRT button on the VCR) will let you make a simplified timer recording without having to use the programming timer. In order to set the IRT properly the clock must be set before starting.

1 Follow the steps 1 through 5 on "Basic recording steps" on pages 41 and 42.

2 Press the REC/IRT button twice to indicate the recording time on the display.

- You may increase the recording time by 30 minutes each time you press the REC/IRT button.
- While you are recording, the remaining recording time is shown on the VCR display.
- At the end of your recording, the display will read "0:00", recording will stop automatically, and the VCR will turn itself off.

REC/IRT Settings Illustration

To stop recording while in the IRT mode:

1 Press the POWER button.

2 Press the STOP button within 10 seconds.

- This can be done either on the VCR or with the remote control.

DELAYED RECORDING

Setting the VCR to record later

Note: The cassette safety tab must be in place in order to record.
To re-record on a cassette which has its safety tab removed.

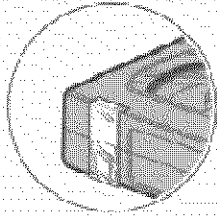

Cover the hole with cellophane tape.

With the delayed recording feature, you can set this VCR so that it automatically turns on and records programs whenever you like – without your being around! You can record a program one time only, or you can automatically record a show every weekday or every week at the same time. You can preset as many as 8 timed recordings at once.

Recording is even easier when you have set up your channels for the VCR Plus+ system. Learn the basics of delayed recording in this section. Then read about the VCR Plus+ system beginning on page 47.

Before you begin

Assemble the information you need for timed recording:

- Be sure that the clock is set to the correct time
- Date and day of the program
- Starting time
- Ending time
- Channel to be recorded
- Blank or erasable videocassette (safety tab intact)

Delayed Recording Steps

You set up the delayed recording using the on-screen Easy Guide System.

1 Insert blank or erasable tape.

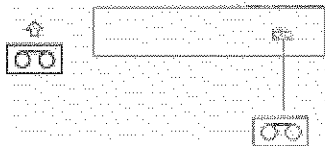

The power comes on automatically and the tape indicator lights on the display.

- If a cassette without its safety tab is inserted, playback starts automatically and timed record won't operate.

2 Turn on the TV and select the video channel (3 or 4).

Or, if you are hooked up with an audio/video cable, set the TV to AUX or VIDEO.

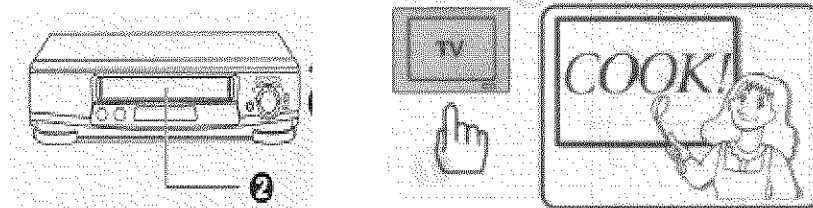

3 Press the PROGRAM button twice for delayed recording.

- Press the PROGRAM button once, the screen for VCR PLUS+ programming of the timer will appear.
- Press the PROGRAM button twice, this screen will appear.

ONE TIME PROGRAMMING

AM	PM
12 1 2 3 4 5 6 7 8 9 10 11	12 1 2 3 4 5 6 7 8 9 10 11

CH	START	END	
-	--:--	--:--	SP
DATE			
--/--/--	END <input type="checkbox"/> PROGRAM		

EXAMPLE: Set the VCR to record "one time", a program on **Channel 8** that starts at **6:00 PM** and ends at **6:30 PM** on **7/10/99**, at the **EP** recording speed.

4 Press the (0) and (8) buttons to select channel 8.

ONE TIME PROGRAMMING			
AM	PM		
121234567891011	121234567891011		
CH	START	END	
08	--:--	--:--	SP
DATE			
--/--/--	CORRECT <input type="checkbox"/> CLEAR		
	END <input type="checkbox"/> PROGRAM		

Note: Remember to press 0 before single-digit channel numbers, times, and dates.

- If you want to record from an external equipment, press the AVX button to select LINE 1 or LINE 2 instead of the channel number.

ONE TIME PROGRAMMING			
AM	PM		
121234567891011	121234567891011		
CH	START	END	
LINE1	--:--	--:--	SP
DATE			
--/--/--	CORRECT <input type="checkbox"/> CLEAR		
	END <input type="checkbox"/> PROGRAM		

- If you make a mistake when entering digits, press the CLEAR button repeatedly to display "-" for the incorrect digit, then reenter the correct digit.

5 Enter the start time by pressing (0), (6), (0) and (0) for 6:00.

ONE TIME PROGRAMMING			
AM	PM		
121234567891011	121234567891011		
CH	START	END	
08	06:00	--:--	SP
	AM <input type="checkbox"/> 1	PM <input type="checkbox"/> 2	
DATE			
--/--/--	CORRECT <input type="checkbox"/> CLEAR		
	END <input type="checkbox"/> PROGRAM		

6 Press the (2) button for PM.

ONE TIME PROGRAMMING			
AM	PM		
121234567891011	121234567891011		

CH	START	END	
08	06 : 00PM	--:--	SP
DATE	CORRECT <input type="checkbox"/> CLEAR		
--/---/---	END <input type="checkbox"/> PROGRAM		

7 Enter the end time by pressing (0), (6), (3) and (0) for 6:30.
The VCR automatically selects PM for you.

ONE TIME PROGRAMMING			
AM	PM		
121234567891011	121234567891011		
CH	START	END	
08	06 : 00PM	06 :30PM	SP
ONE TIME / DAILY / WEEKLY <input type="checkbox"/> 5			
DATE	CORRECT <input type="checkbox"/> CLEAR		
07 / 08 / 98WED	END <input type="checkbox"/> PROGRAM		

8 Press the (5) button to select One Time Recording.

ONE TIME PROGRAMMING			
AM	PM		
121234567891011	121234567891011		
CH	START	END	
08	06 : 00PM	06 :30PM	SP
ONE TIME / DAILY / WEEKLY <input type="checkbox"/> 5			
DATE	CORRECT <input type="checkbox"/> CLEAR		
07 / 08 / 98WED	END <input type="checkbox"/> PROGRAM		

Types of Delayed Recordings

- ONE TIME Records one show at a particular date and time.
- DAILY Records a show at the same time every day of the week, Monday through Friday.
- WEEKLY Records a show at the same day and time every week.

9 Enter the recording date by pressing (0), (7), (1) and (0) for 7/10/99.

ONE TIME PROGRAMMING			
AM	PM		
121234567891011	121234567891011		
CH	START	END	
08	06 : 00PM	06 :30PM	SP
ONE TIME / DAILY / WEEKLY <input type="checkbox"/> 5			
DATE	CORRECT <input type="checkbox"/> CLEAR		
07 / 10 / 99SAT	END <input type="checkbox"/> PROGRAM		

10 Press the TAPE SPEED button to select the recording speed EP.

ONE TIME PROGRAMMING			
AM	PM		
121234567891011	121234567891011		
CH	START	END	
08	06 : 00PM	06 :30PM	EP
ONE TIME / DAILY / WEEKLY <input type="checkbox"/> 5			

USING THE VCR PLUS+ SYSTEM FOR RECORDING

About the VCR Plus+ system

This handy feature makes timed recording a snap. You don't need to enter the specific channel, date, time or duration of a program. All you enter is its PlusCode programming number – a number of up to eight digits. This special code is easy to find in your favorite TV program guide or daily newspaper. Here's a sample page from TV Guide showing PlusCode numbers next to each program.

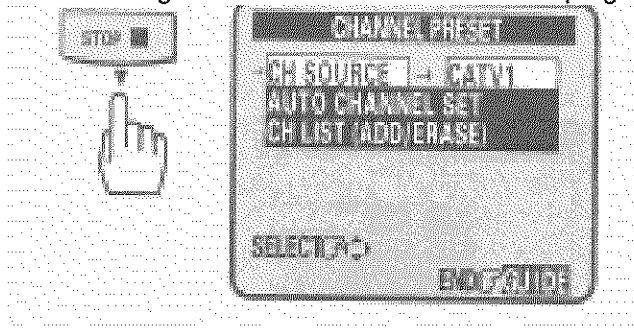

Your local channels may be different from the VCR Plus+ channel codes. To get ready to record with the VCR Plus+ system you need to assign your local broadcast and cable channel numbers to the VCR Plus+ channel codes already stored in your VCR's memory. This is called *channel setup* and you do it using the on-screen Easy Guide System and the following step-by-step instructions. Then you will be ready to begin VCR Plus+ recording, also using the on-screen Easy Guide System.

VCR Plus+® and PlusCode® are trademarks of Gemstar Development Corp.

Channel setup

Before you begin

1 Look for a listing like this one in your local TV program guide or Sunday newspaper TV section. Notice the small numbers to the right of the station name.

These are the VCR Plus+ channel numbers that you will use in the channel setup procedure.

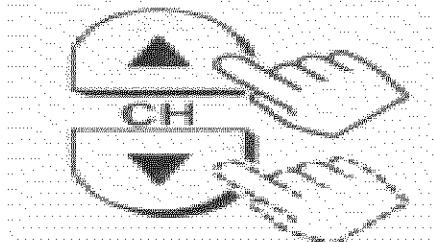

2 Make a list of the VCR Plus+ channel numbers and the channel numbers you are receiving them on. If there are any difference, **YOUR** channel numbers must be assigned to the corresponding VCR Plus+ number. (See Example)

EXAMPLE

VCR Plus+ Channel Number	Channel Number You Receive
04 (ind.)	04
06 (ABC)	06
20 (PBS)	08
42 (Cable News Network)	38

Note in the example that the channel numbers are the same except for **20** (received on channel 8) and **42** (received on channel 38). These two channels must be assigned.

EASY DELAYED RECORDING WITH THE VCR PLUS+ SYSTEM

This setup should be performed if you are using an Antenna or Cable without a cable box. (Hookups [A], [B], [C] or [D].) If you receive all your channels through a cable box (Hookups [E], [F] or [G]) please refer to page 25 "cable box setup" in "First Time Setup" section.

VCR Plus+ setup - Channel setup

The following shows the procedure you should perform when you are receiving the Cable News Network (channel 42 with the VCR Plus+ system) on channel 38.



Matching Broadcast CH Numbers to VCR Plus+ Channels for Home Antenna or Cable (No Cable Box) Setup (Hookups [A], [B], [C] or [D].)

1 Turn on the TV and select the Video channel (3 or 4).

Or, if you are hooked up with an audio/video cable, set the TV to AUX or VIDEO.

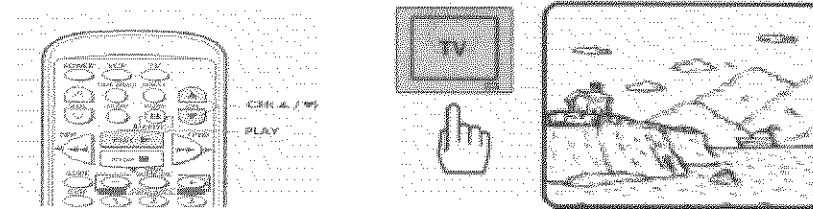

2 Press the GUIDE button.

The main on-screen menu will appear on the TV screen.

3 Press the (4) button to select CHANNEL PRESET.

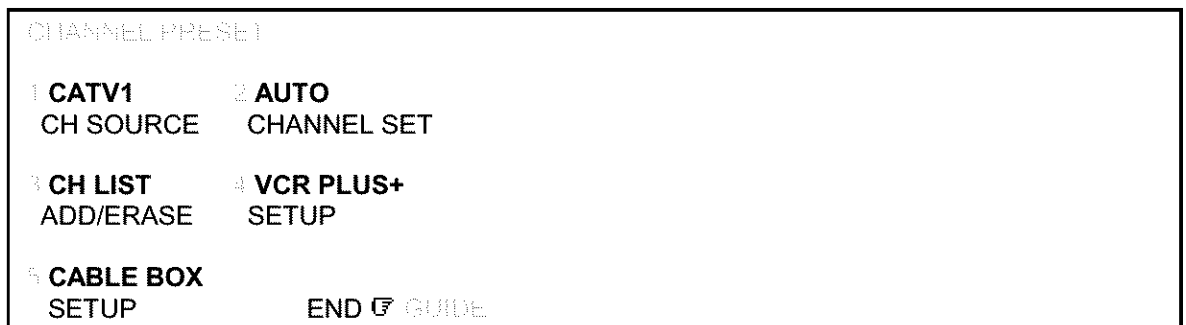

4 Press the (4) button to select VCR PLUS+ SETUP.

A small arrow points to a blank "--" in the CHANNEL column.

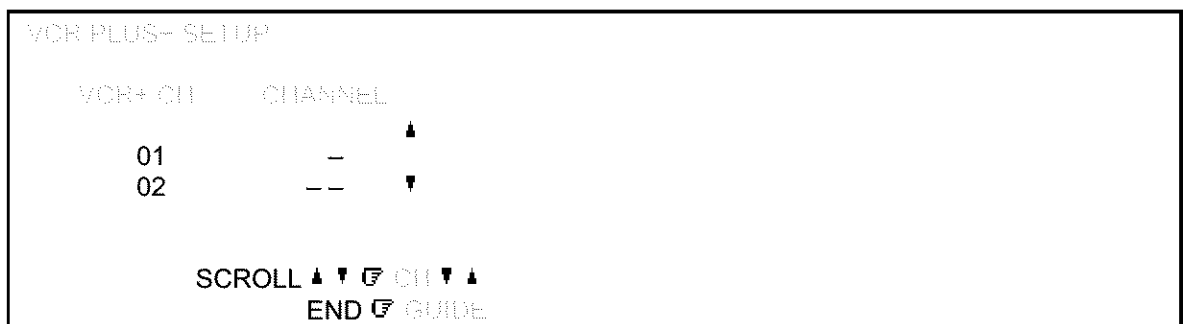

Note: If your broadcast channel number is the same as the VCR Plus+ Channel in your TV listing do not enter any number.

5 Press the **CH** (▲/□) button to move up and down through the channel list until you reach **VCR Plus+ CH42**.



6 Press the number buttons to assign your broadcast channel number to the corresponding VCR Plus+ channel.

In this example broadcast channel 38 is assigned to VCR Plus+ channel 42.

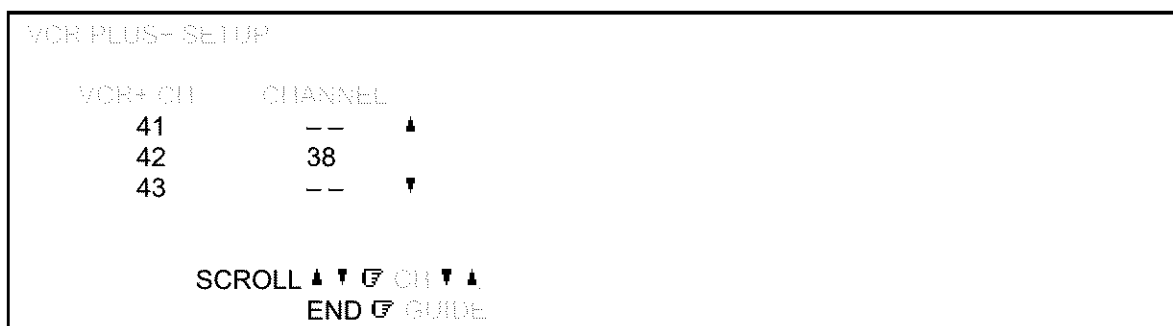

Note: If you enter a wrong digit, Press the **CLEAR** button to erase the wrong number and enter the correct one.

7 Repeat steps 5 - 6 for all channels that need to be assigned.

8 Press the **GUIDE** button to end the setup procedure.

You are ready to begin delayed recording with the VCR plus+ system.

Using the VCR Plus+ system to record a program (by using TV screen)

1 Insert a blank or erasable tape.

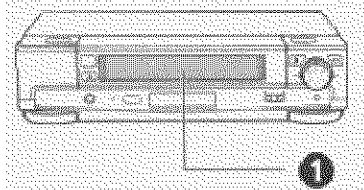

The power comes on automatically and the tape indicator lights on the display.

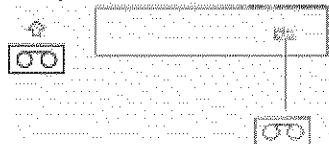

- When a cassette without its safety tab is inserted, playback starts automatically and VCR Plus+ recording won't operate.

2 Press the **PROGRAM** button.

VCR PLUS+

FOR VCR PLUS RECORDING
ENTER PLUS CODE NUMBER

AND THEN PRESS **ENT**

PLUS CODE

—

FOR MANUAL PROG **↵** PROGRAM

3 Press the number buttons to enter the PlusCode number of the program you want to record.

VCR PLUS+

FOR VCR PLUS RECORDING
ENTER PLUS CODE NUMBER
AND THEN PRESS **ENT**

PLUS CODE

123

PPROCEED **↵** **ENT**

Note: This number can be up to eight digits. If you enter a wrong digit, press the CLEAR button and enter the correct one.

4 Press the 100/ENT button to store the PlusCode number in the VCR's memory.

ONE TIME PROGRAMMING

AM

PM

12 123 4 56 7 89 10 11 **12 123 4 56 7 89 10 11**

CH

START

END

03 06 : 30PM 07 :00PM SP

ONE TIME / DAILY / WEEKLY **↵** 5

DATE

ERASE **↵** CLEAR

07 / 17 / 99SAT END **↵** PROGRAM

Note: If you accidentally enter a nonexistent PlusCode number, the VCR gives you an error message that disappears from the screen in about 10 seconds.

VCR PLUS+

CHECK PLUS CODE NUMBER

INVALID ENTRY

PLUS CODE

000000000

PPROCEED **↵** **ENT**

5 Press the (5) button to select ONE TIME, DAILY or WEEKLY RECORDING.

ONE TIME PROGRAMMING

AM

PM

12 123 4 56 7 89 10 11 **12 123 4 56 7 89 10 11**

CH

START

END

03 06 : 30PM 07 :00PM SP

ONE TIME / DAILY / WEEKLY **↵** 5

Using the VCR Plus+ system to record a program (by using VCR's display)

You can use the VCR Plus+ system to program the timer, observing the VCR's display, without turning on the power to the VCR and TV.

Notes:

- If you use the VCR Plus+ system to program the timer while observing the VCR's display, you can only program a one-time recording.
- To stop programming, press the POWER button to turn the VCR power on.

1 Insert a blank or erasable tape.

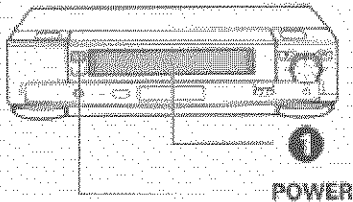

The power comes on automatically and the tape indicator lights on the display.

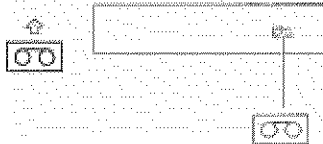

- When a cassette without its safety tab is inserted, playback starts automatically and VCR Plus+ recording won't operate.

2 Press the POWER button to turn off the VCR.



3 Press the PROGRAM button.

The clock display switches to the indication shown on the right.

- If eight programs have already been stored in memory, "FULL" will appear in the VCR's display.

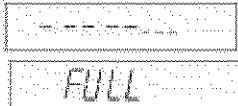

4 Press the number buttons to enter the PlusCode number of the program you want to record.



Note: This number can be up to eight digits. If you enter a wrong digit, press the CLEAR button and enter the correct one.

5 Press the 100/ENT button to enter the PlusCode number in the VCR's memory.

The start time and channel will appear. Check the details of the program.

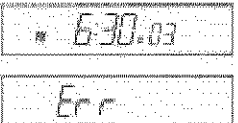

- If "Err" appears, check the PlusCode of the program and try to enter it again.

6 Press the PROGRAM button to complete your programming or continue with additional programs.



The delayed recording indicator will display on the VCR.
This tells you that the VCR will automatically record at the times and dates you have programmed.

When you have set up all the timed recordings you want:

- Don't forget to load a videocassette (with the safety tab still attached) to record on.
- If using a cable box the VCR can control, turn on the cable box before the time the recording is to begin. Please refer to "**Cable Box Setup**", on Page 25 in the "**First Time Setup**" section.

Important: Your timed recording settings take effect when you turn off the power on the VCR.

Caution of VCR Plus+ Recording

After entering a PlusCode number, check the information displayed with the "PROGRAM REVIEW". If there is (are) any unnecessary program(s), please cancel or correct it (them). Please refer to Page 53, "Reviewing what you have programmed".

PROGRAM REVIEW

Reviewing what you have programmed

You can look back over any of the recordings you have preset and if you need to, clear out any of the programs. Normal programs will clear automatically once recording is complete, but daily and weekly setting must be cleared out manually.

1 Press the **GUIDE** button.

The main on-screen menu will appear on the TV screen.

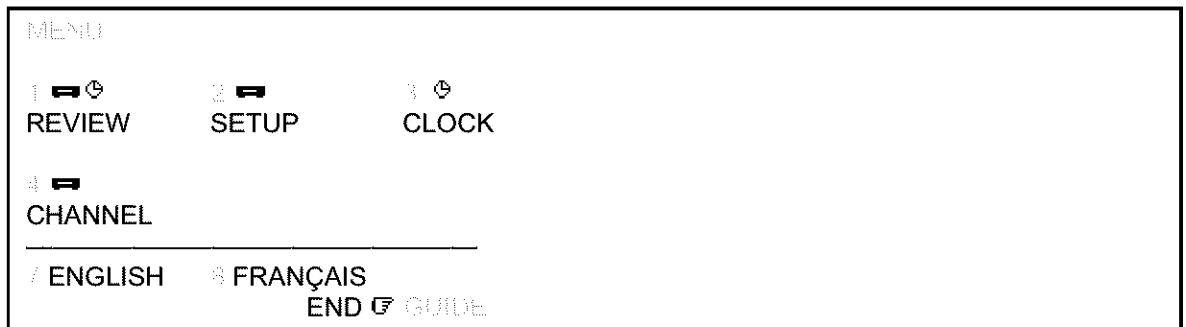

2 Press the **(1)** button for the **PROGRAM REVIEW** option.

This brings up the screen setting for the first program.

If you want to clear this program, press the **CLEAR** button to remove this program.



3 Keep pressing the **(1)** button to cycle through all the programs you have preset.

• The screen will display the next program, if there are more, or it will switch back to the main menu.



4 Press the **GUIDE** button to end.

PROGRAMMING THE VCR REMOTE TO CONTROL YOUR TV

The VCR remote control can be programmed to control many TV brands that are remote controlled.

1 Turn on the TV.

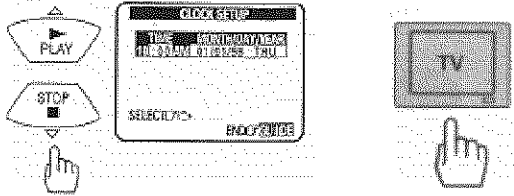

2 Point VCR remote control toward TV.

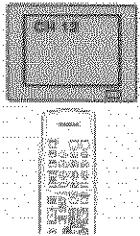

3 Press and hold the "TV" button.

4 Press the remote button corresponding to your TV brand as shown in the set-up chart. The TV channel will change to confirm that the remote control has been set.



TV Brand	Press "TV" and this remote button	TV Brand	Press "TV" and this remote button	TV Brand	Press "TV" and this remote button	TV Brand	Press "TV" and this remote button
Hitachi	1	Sanyo	5	Panasonic 2	9	JVC	100/ENT
Zenith	2	Goldstar 1	6	RCA	0	Sharp 1	VOL ▲
Sony	3	Toshiba	7	Panasonic 1	CH ▲	Sharp 2	DISPLAY
Magnavox	4	Goldstar 2	8	Mitsubishi	CH □	Hitachi 2	DISPLAY

Note: If your TV brand is not listed on the Set-Up Chart, try all the buttons listed in the chart until the TV changes channels. If the TV channel does not change, you won't be able to program the remote for your TV.

Using the VCR remote to control your TV

1 Press the "TV" button on remote control.

2 Point VCR remote control toward TV.

3 Press buttons corresponding to the functions available on your TV remote control.

PROGRAMMING THE VCR REMOTE TO CONTROL YOUR CABLE BOX

The VCR remote control can be programmed to control many cable boxes that are remote controlled. You can easily change channels.

- 1 Turn on cable box.
2. Point VCR remote control toward cable box.
3. Press and hold the CATV button.
4. Press the number button corresponding to your cable box as shown in the set up chart. The cable box channel will change to confirm that the remote control has been set.

Cable box	Press CATV and this number button	Cable box	Press CATV and this number button
Jerrold 1	1	Zenith	5
Jerrold 2	2	Scientific Atlanta	6
Jerrold 3	3	Pioneer	7
Hamlin	4	Philips	8

Note: if your cable box is not listed on the setup chart, try all the buttons listed in the chart until the cable box changes channels. If the cable box channel does not change, you won't be able to program the remote for your cable box.

Using the VCR remote to control your cable box

- 1 Press the CATV button on remote control.
- 2 Point VCR remote control toward cable box.
- 3 Press the button corresponding to the functions available on your cable box remote control.

INTEGRATING YOUR STEREO SYSTEM WITH YOUR VCR

Hookup

When your VCR is connected to a stereo system, you can:

- Make high quality "audio only" recordings for up to 6 hours (on a T-120 video cassette tape).
- Receive quality stereo sound from your VCR through your stereo system.
- Use the VCR as an extra audio tape deck for dubbing.

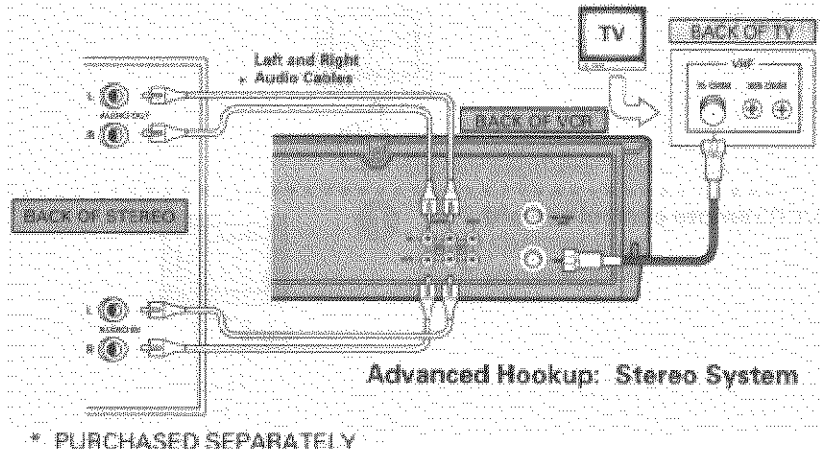

To record from stereo

BEFORE YOU BEGIN...

- Make sure the VCR is connected to your stereo system, as shown above.
- Make sure that "STEREO" audio is selected from the VCR Set-Up Menu, as shown on **Page 42**, of "RECORDING OPERATION" Section, "Stereo vs. mono sound".
- Select VCR recording speed (SP or EP) as shown on **page 39**, of "RECORDING OPERATIONS" Section, "Basic Recording Steps".

1 Press the AVX button on remote control, so that L1 (line) appears on the display.



2 Turn on stereo, and start the selection you wish to record.

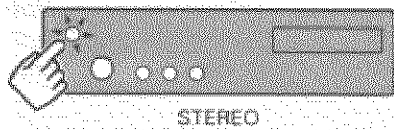

3 Press the REC button on the remote control or the REC/IRT button on the VCR to start recording.



4 Press the STOP button or remote control to stop recording.



COPYING TAPES FROM A CAMCORDER

Hookup

You may use your VCR to copy tapes from any camcorder onto standard VHS cassette tapes.

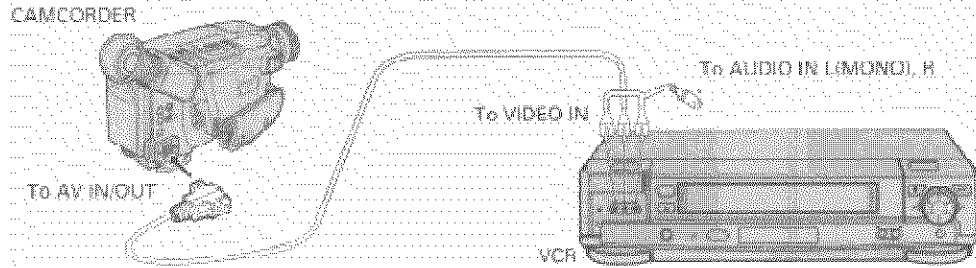

NOTE: If your camcorder is not stereo (has only one audio plug), connect it to the AUDIO IN-L(MONO) input on the front of the VCR.

* It is not necessary to connect the S-VIDEO jack.

To copy from a camcorder

BEFORE YOU BEGIN...

Connect the camcorder's AV output cable to the audio/video jacks on the front of your VCR.

1 Press the AVX button on remote control, to display L2 (line) on the TV display.



2 Press the REC, then PAUSE buttons on the VCR remote control. The VCR will go into Record/Pause.

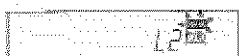

3 Press the PLAY button on the camcorder. You will see the camcorder tape being played on the TV.

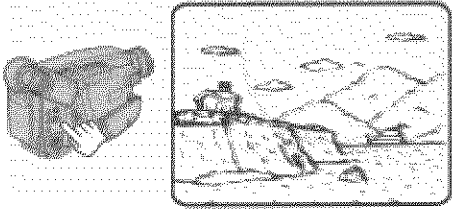

4 When you see the part of the Camcorder tape you wish to copy, press the VCR PAUSE button again to release pause and start copying the camcorder tape.

- Press the stop button to finish recording.

REC

LINE2

COPYING FROM ONE VCR TO ANOTHER VCR (DUBBING)

Hookup

If you have two VCRs, you may use one VCR to record a tape that is being played back in the other VCR.

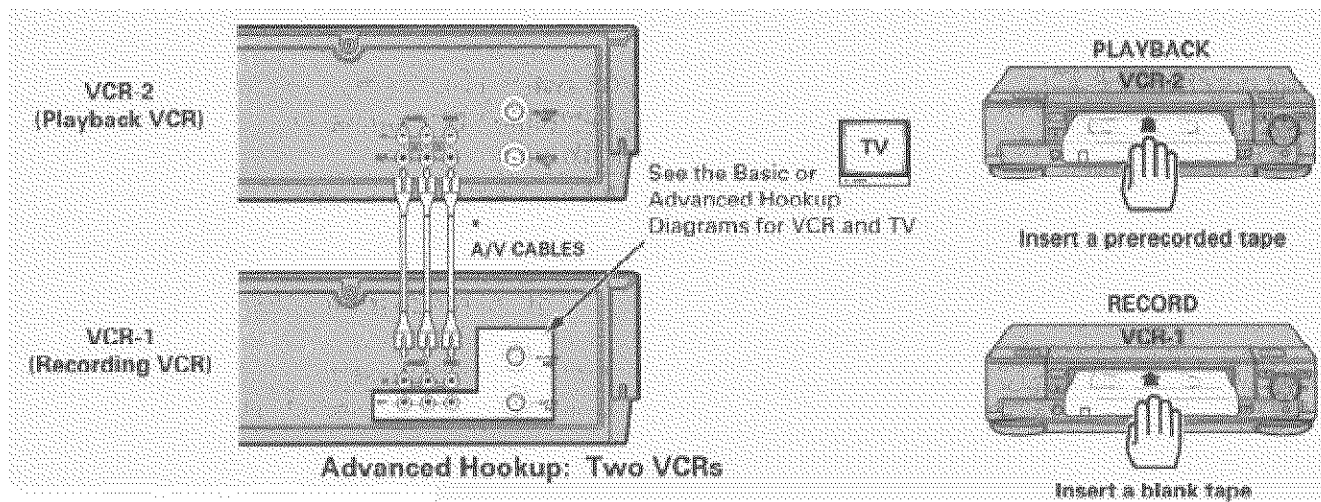

* PURCHASED SEPARATELY

To copy from one VCR to another VCR

1 Press the AVX button on the remote control of VCR-1 so that L1 (line) appears in the display.



2 Press the REC, then PAUSE buttons on VCR-1. The VCR will go into Record/Pause.



3 Press the PLAY button on VCR-2. You will see the taped program being played on the TV.

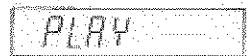

4 When you see the part of the program you wish to record, press the PAUSE button on VCR-1 again to release pause and start recording.

• Press the STOP button to finish recording.

PROBLEM GUIDE / MAINTENANCE

Problem guide

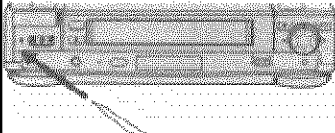
No power	<ul style="list-style-type: none"> • Make sure the VCR is plugged into an AC outlet.
Remote control doesn't work	<ul style="list-style-type: none"> • Make sure the batteries are fresh, and properly installed.
Won't record	<ul style="list-style-type: none"> • Safety tab has been removed from cassette (VCR will automatically eject the tape).
Won't play back	<ul style="list-style-type: none"> • Make sure the TV/VCR switch is set to the VCR mode. • Make sure the TV is set to the VCR channel (3 or 4) or AUX (if using direct audio/video hookup).
Won't make timer recordings	<ul style="list-style-type: none"> • The VCR power must be turned off to activate timer recording. • Clock is not set correctly. • Programs entered incorrectly. • Programs exceed the length of the cassette. Use the EP recording speed for maximum programming. • Safety tab has been removed from cassette.
Snowy picture in playback	<ul style="list-style-type: none"> • Snow or picture noise is normal during search, still, and slow Playback. • Head cleaning may be required. • Tape is worn or of inferior quality - adjust tracking controls.
Snowy picture in normal TV viewing	<ul style="list-style-type: none"> • Check antenna or cable connections.
Clock shows -- : --	<ul style="list-style-type: none"> • Power has been interrupted - reset the clock. • Reset the clock.
Erratic VCR display	<ul style="list-style-type: none"> • Push the reset switch (behind the cover on the VCR front) with a sharp pointed instrument (pen, toothpick, etc.). 

Maintenance

Regular periodic maintenance is required to maintain optimum VCR performance. Such maintenance and adjustments should not be attempted by the user. Please consult your service dealer for further information.

Auto Head Cleaning System

This system cleans the video heads automatically when a cassette is inserted and ejected or the VCR is turned on or off while a cassette is in the VCR, to prevent dirt from accumulating on the heads.

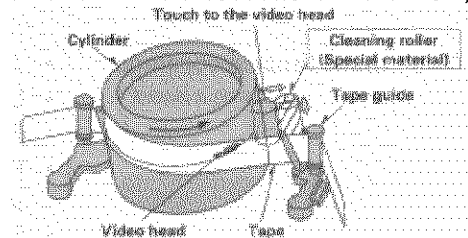

Note: Mechanical sound is heard during head cleaning.

NOTE: Dirt accumulation on the video heads will cause the playback picture to become noisy. **Heavy accumulations due to abnormal usage, or the use of poor quality tapes may be beyond the capabilities of**

the Auto Head Cleaning System, and may require the video heads to be professionally cleaned by a qualified service dealer.



TECHNICAL SPECIFICATIONS

Format: -----VHS
 Video Signal System: -----NTSC color EIA standard
 Record/Playback System: -----Video: 4 head
 -----Audio: VHS Hi-Fi stereo record/playback system
 Tape Speed: -----33.35 mm/sec (SP), 16.67 mm/sec (LP) (playback only),
 -----11.12 mm/sec (EP)
 RF Input: -----UHF/VHS 75 ohm
 Tuner: -----USA: 181 channel tuning ability* (125 cable channels)
 -----Canada: 178 channel tuning ability* (122 cable channels)
 Type: -----Auto programming frequency synthesis
 Power Input: -----AC 120V 60 Hz
 Power Consumption: -----23W nominal
 Cabinet Size: -----17-1/8" (W) x 3-7/8" (H) x 11-1/8" (D)
 -----43.5 cm (W) x 9.9 cm (H) x 28.2 cm (D)
 Weight: -----8.8 lbs. (4.0 kg)
 Storage Temperature: -----4°F to 131°F
 Operating Temperature: -----41°F to 104°F
 Accessories: -----1 coaxial cable (Part No. EW10251)
 -----1 remote control unit (Part No. HL11133),
 -----2 AA batteries

*Check your cable company's compatibility requirements.

For information about how to obtain these and other HITACHI accessories, please call HiTRON, Inc. TOLL FREE at 1-800-995-4500 (in the continental United States). For ALASKA and HAWAII, please contact the nearest Hitachi Regional Office.

Design and specifications subject to change without notice.

Hitachi Service Hotline

Authorized Hitachi service facilities are available throughout the US and Canada. For the location nearest to you, call the Hitachi Service Hotline at one of these numbers:

In the continental U.S.A

DIAL TOLL FREE
 7 days a week, 24 hours a day
1-800-HITACHI
 (1-800-448-2244)
 You must state your zip code when calling

In Canada

MONTREAL 514-956-9882