

# HITACHI

VIDEO CASSETTE RECORDER  
VT-UX617A

## Owner's manual



### Using these quality features:

- Tape navigation feature allows you to automatically locate a program you want to view, and also allows you to list the recorded contents on the TV screen for every tape you have recorded on this VCR.
- The VCR Plus+\* programming system allows you to program the VCR for timer recording by simply entering a PlusCode\* number.

\*VCR Plus+C3 and PlusCode are trademarks of Gemstar Development Corporation.

The VCR Plus+ system is manufactured under license from Gemstar Development Corporation. With the VCR Plus+C3 system, this video cassette recorder can automatically select the appropriate channel on your compatible cable box or satellite receiver. C3 and VCR Plus+C3 are trademarks of Gemstar Development Corporation.

### • COMMERCIAL ADVANCE™

™"Commercial Advance™ is a trademark of Arthur D. Little Enterprises.

A Jerry Iggulden invention licensed by Arthur D. Little Enterprises."

- **Displaying captions.**
- **Multi-channel TV sound (MTS).**
- **8-program/1-year preset recording.**
- **Auto clock set feature allows you to automatically set the present time using a time signal.**
- **Auto head cleaning system minimizes the need for accessory cleaners and professional head cleaning.**
- **Auto tracking system automatically adjusts the tracking so the picture is optimized.**
- **Frequency synthesized tuner provides easy, preset tuning of up to 68 broadcast TV channels and 125 cable channels.**
- **VHS Hi-Fidelity sound in playback.**
- **Illuminated remote control for use with your VCR and TV**
- **On-screen programming guide.**

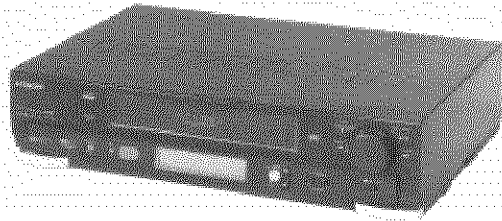

**Hitachi Home Electronics (America), Inc.**  
3890 Steve Reynolds Blvd., Norcross, GA 30093  
Tel. 770-279-5600

**HITACHI (HSC) CANADA INC**  
3300 Trans Canada Highway, Pointe Claire,  
Quebec, H9R 1B1, CANADA  
Tel. 514-697-9150

**HITACHI SALES CORPORATION OF HAWAII, INC**  
3219 Koapaka Street, Honolulu, Hawaii 96819  
Tel. 808-836-3621

## TABLE OF CONTENTS

FOR YOUR SAFETY .....	5
IMPORTANT SAFEGUARDS.....	6
CUSTOMER CONTROLS.....	8
VCR Customer Controls .....	9
VCR Customer Controls .....	10
Remote Control Customer Controls .....	10
REMOTE OPERATION .....	12
Install batteries in the remote control .....	12
Operating in the remote control.....	13
CASSETTE TAPES .....	14
Types.....	14
Safety tabs prevent erasure.....	14
Insertion .....	14
Removal.....	15
BASIC ANTENNA HOOKUP [A] .....	15
WITH THIS HOOKUP .....	15
ADVANCED ANTENNA HOOKUP -AV HOOKUP [B].....	16
WITH THIS HOOKUP .....	16
BASIC CABLE HOOKUP [C].....	16
WITH THIS HOOKUP .....	16
ADVANCED CABLE HOOKUP -AV HOOKUP [D] .....	17
WITH THIS HOOKUP.....	17
BASIC CABLE HOOKUP -WITH CABLE BOX [E].....	18
WITH THIS HOOKUP .....	18
ADVANCED CABLE HOOKUP -WITH CABLE BOX [F].....	19
WITH THIS HOOKUP .....	19
ADVANCED CABLE HOOKUP -WITH CABLE BOX AND SPLITTER [G] .....	19
WITH THIS HOOKUP.....	19
BASIC DSS HOOKUP [H].....	20
WITH THIS HOOKUP .....	20
ADVANCED DSS HOOKUP [I] .....	21
WITH THIS HOOKUP .....	21
SETTING THE CLOCK -AUTOMATIC MODE .....	22
Tips .....	22
Setting the clock automatically .....	22
SETTING THE CLOCK -AUTOMATIC MODE WITH CABLE BOX .....	23
If your VCR is hooked up to a cable box (Hookups [E], [F] or [G]).....	23
SETTING THE CLOCK -TIME ZONE SETTING/DAYLIGHT SAVING TIME SETTING .....	24
What to do if the displayed time drifts from the current time by more than an hour .....	24
SETTING THE CLOCK -MANUALLY .....	25
To set the clock manually.....	25
PRE-TUNING THE VCR TUNER .....	27
Presetting the received channels without using a cable box (Hookups [A], [B], [C] or [D])..	27
When automatic presetting of channels are finished .....	28
To add or erase channels .....	29
Auto blue setting .....	29
CABLE BOX SETUP.....	30

DSS BOX SETUP.....	34
(Hookups [H] or [I].).....	34
PLAYBACK.....	36
To playback a recorded tape.....	36
Rewinding the tape.....	37
Rewinding the tape.....	37
To remove noise from the picture.....	37
SPECIAL PLAYBACK EFFECTS.....	38
Variable speed playback.....	38
Choosing a mode for audio playback.....	39
Precautions.....	43
Markings after delayed recording is finished.....	43
SHUTTLE CONTROL.....	43
Using the shuttle ring on the remote control.....	43
USING THE "INDEX" FEATURE.....	44
To find specific sections on a tape using the "INDEX" feature.....	44
VIEWING THE ON-SCREEN DISPLAY.....	45
Switching between the clock, time counter and time of remaining tape.....	45
INDEX WITH THE TIME COUNTER.....	46
To find specific sections on a tape.....	46
RECORDING A PROGRAM.....	47
Before you record.....	47
Basic recording steps.....	48
RECORDING A PROGRAM -RECORDING TIPS.....	50
To watch one program while recording another.....	50
To change the channel being recorded.....	50
To record a Second Audio Program (SAP).....	51
Stereo vs. mono sound.....	52
INSTANT RECORDING TIMER.....	52
Using the Instant Recording Timer (IRT).....	52
DELAYED RECORDING.....	54
Setting the VCR to record later.....	54
Before you begin.....	54
When the DSS box has been set up and <CATV1> or <CATV2> is specified for "1 CHANNEL" on the "CHANNEL PRESET" screen.....	57
USING THE VCR PLUS+ SYSTEM FOR RECORDING.....	58
About the VCR Plus+ system.....	58
Channel setup.....	59
EASY DELAYED RECORDING WITH THE VCR PLUS+ SYSTEM.....	60
VCR Plus+ setup - Channel setup.....	60
VCR Plus+ setup - Channel setup.....	61
Using the VCR Plus+ system to record a program.....	61
PROGRAM REVIEW.....	64
Reviewing what you have programmed.....	64
TAPE NAVIGATION.....	65
Tape navigation and directory screen.....	65
Storing tape data in memory.....	66
How to locate the beginning of a program or a non-recorded (blank) section.....	67



Tape data menu.....	68
Precautions.....	71
DISPLAYING CAPTIONS .....	72
PROGRAMMING THE VCR REMOTE TO CONTROL YOUR TV.....	73
Using the VCR remote to control your TV.....	74
INTEGRATING YOUR STEREO SYSTEM WITH YOUR VCR.....	75
Hookup.....	75
To record from stereo .....	75
COPYING TAPES FROM A CAMCORDER.....	76
Hookup.....	76
To copy from a camcorder.....	76
COPYING FROM ONE VCR TO ANOTHER VCR (DUBBING).....	77
Hookup.....	77
To copy from one VCR to another VCR.....	78
PROBLEM GUIDE .....	79
Problem guide.....	79
MAINTENANCE.....	79
Maintenance.....	80
TECHNICAL SPECIFICATIONS.....	80
Technical specifications .....	80

POWER SUPPLY: AC 120V, 60 Hz ONLY.

The POWER switch turns the VCR on and off, leaving the clock/timer unaffected. If the unit is to be left unattended for a long period, it is recommended that the unit be completely switched off and unplugged.

Illustrated below is the label on the back of your unit.



**CAUTION**  
RISK OF ELECTRIC SHOCK  
DO NOT OPEN



 This symbol warns the user that uninsulated voltage within the unit may have sufficient magnitude to cause electric shock. Therefore, it is dangerous to make any kind of contact with any inside part of this unit.

 This symbol alerts the user that important literature concerning the operation and maintenance of this unit has been included. Therefore, it should be read carefully in order to avoid any problems.

**CAUTION: TO REDUCE THE RISK OF ELECTRIC SHOCK, DO NOT REMOVE COVER (OR BACK). NO USER-SERVICEABLE PARTS INSIDE. REFER SERVICING TO QUALIFIED SERVICE PERSONNEL.**

**WARNING:** Many television programs and films are copyrighted. In certain circumstances, copyright law may apply to private in-home videotaping of copyrighted materials.

**WARNING:** TO PREVENT FIRE OR ELECTRIC SHOCK, DO NOT EXPOSE THIS APPLIANCE TO RAIN OR MOISTURE.

**CAUTION:** TO PREVENT ELECTRIC SHOCK, MATCH WIDE BLADE OF PLUG TO WIDE SLOT, FULLY INSERT.

**Caution to the user:** Changes or modifications not expressly approved by the party responsible for compliance could void the user's authority to operate the equipment.

**"Note to CATV system installer:** This reminder is provided to call the CATV system installer's attention to Article 820-40 of the NEC that provides guidelines for proper grounding and, in particular, specifies that the cable ground shall be connected to the grounding system of the building, as close to the point of cable entry as practical".

In addition to the careful attention devoted to quality standards in the manufacture of your video product, safety is a major factor in the design of every instrument. But, safety is your responsibility too. This page lists important information that will help to assure your enjoyment and proper use of a Video Cassette Recorder and accessory equipment. Please read it carefully before operating your video product and keep it in a handy place for future reference.

## INSTALLATION

**1 Read and Follow Instructions** -- All the safety and operating instructions should be read before the video product is operated. Follow all operating and use instructions.

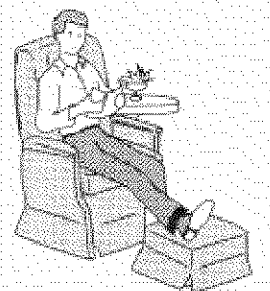

**2 Retain Instruction** -- The safety and operating instructions should be retained for future reference.

**3 Heed Warnings** -- Comply with all warnings on the video product and in the operating instructions.

**4 Polarized Plug** -- This video product is equipped with a polarized alternating current line plug (a plug having one blade wider than the other). This plug will fit into the power outlet only one way. This is a safety feature. If you are unable to insert the plug fully into the outlet, try reversing the plug. If the plug should still fail to fit, contact your electrician to replace your obsolete outlet. To prevent electric shock do not use this polarized plug with an extension cord, receptacle or other outlet unless the blades can be fully inserted without blade exposure. If you need an extension, use a polarized cord.



**5 Power Sources** -- This video product should be operated only from the type of power source indicated on the marking label. If you are not sure of the type of power supply to your home, consult your video dealer or local power company. For video products intended to operate from battery power, or other sources, refer to the

operating instructions.

**6 Overloading** -- Do not overload wall outlets and extension cords as this can result in a risk of fire or electric shock. Overloaded AC outlets and extension cords are dangerous, and so are frayed power cords, damaged or cracked wire insulation and broken plugs. They may result in a shock or fire hazard. Periodically examine the cord and have it replaced by your service technician if appearance indicates damage or deteriorated insulation.

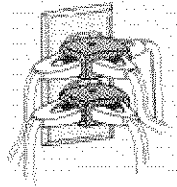

**7 Power Cord Protection** -- Power supply cords should be routed so that they are not likely to be walked on or pinched by items placed upon or against them, paying particular attention to cords at plugs, convenience receptacles, and the point where they exit from the appliance.

**8 Ventilation** -- Slots and openings in the cabinet are provided for ventilation to ensure reliable operation of the video product and to protect it from overheating. These openings must not be blocked or covered. The openings should never be blocked by placing the video product on a bed, sofa, rug or other similar surface. This video product should never be placed near or over a radiator or heat register. This video product should not be placed in a built-in installation such as a bookcase or rack unless proper ventilation is provided or the video product manufacturer's instructions have been followed.

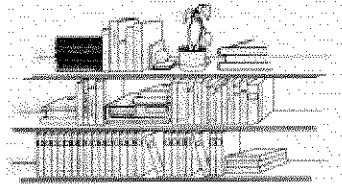

**9 Attachments** -- Do not use attachments unless recommended by the video product manufacturer as they may cause hazards.

**Caution:** Maintain electrical safety. Powerline operated equipment or accessories connected to this unit should bear the UL listing mark or CSA certification mark on the accessory itself and should not have been modified so as to defeat the safety features. This will help avoid any potential hazard from electric shock or fire. If in doubt, contact qualified service personnel.

**10 Water and Moisture** -- Do not use this video product near water - for example, near a bath tub, wash bowl, kitchen sink, or laundry tub, in a wet basement, or near a swimming pool, and the like.

**11 Accessories** -- Do not place this video product on an unstable card, stand, tripod, bracket or table. The video product may fall, causing serious injury to a child or adult, and serious damage to the appliance. Use only with a cart, stand, tripod, bracket or table recommended by the manufacturer, or sold with the video product. Any mounting of the product should follow the manufacturer's instructions, and should use a mounting accessory recommended by the manufacturer.

**11A** An appliance and cart combination should be moved with care. Quick stops, excessive force, and uneven surfaces may cause the appliance and cart combination to overturn.

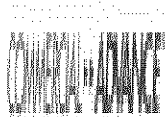

**12 Outdoor Antenna Grounding** -- If an outside antenna or cable system is connected to the video product, be sure the antenna or cable system is grounded so as to provide some protection against voltage surges and built-up static charges. Section 810 of the National Electrical Code, ANSI/NFPA No. 70, provides information with respect to proper grounding of the mast and supporting structure, grounding of the lead-in wire to an antenna discharge unit, size of grounding conductors, location of antenna-discharge unit, connection to grounding electrodes, and requirements for the grounding electrode. See example below.

**EXAMPLE OF ANTENNA GROUNDING**

**13 Power Lines** -- An outside antenna system should not be located in the vicinity of overhead power lines or

other electric light or power circuits, or where it can fall into such power lines or circuits. When installing an outside antenna system, extreme care should be taken to keep from touching or approaching such power lines or circuits as contact with them might be fatal. Installing an outdoor antenna can be hazardous and should be left to a professional antenna installer.

## USE

**14 Cleaning** -- Unplug this video product from the wall outlet before cleaning. Do not use liquid cleaners or aerosol cleaners. Use a damp cloth for cleaning.

**15 Object and Liquid Entry** -- Never push objects of any kind into this video product through openings as they may touch dangerous voltage points or short-out parts that could result in a fire or electric shock. Never spill liquid of any kind on the video product.

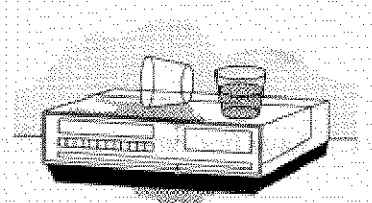

**16 Lightning** -- For added protection for this video product during a lightning storm, or when it is left unattended and unused for long periods of time, unplug it from the wall outlet and disconnect the antenna or cable-system. This will prevent damage to the video product due to lightning and power-line surges.

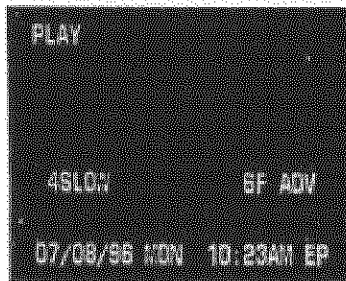

## SERVICE

**17 Servicing** -- Do not attempt to service this video product yourself as opening or removing covers may expose you to dangerous voltage or other hazards. Refer all servicing to qualified service personnel.

**18 Conditions Requiring Service** -- Unplug this video product from the wall outlet and refer servicing to qualified service personnel under the following conditions.

- a. When the power-supply cord or plug is damaged.
- b. If liquid has been spilled, or objects have fallen into the video product.
- c. If the video product has been exposed to rain or water.
- d. If the video product does not operate normally by following the operating instructions. Adjust only those controls that are covered by the operating instructions. Improper adjustment of other controls may result in damage and will often require extensive work by a qualified technician to restore the video product to its normal operation.
- e. If the video product has been dropped or the cabinet has been damaged.
- f. When the video product exhibits a distinct change in performance - this indicates a need for service.

**19 Replacement Parts** -- When replacement parts are required, have the service technician verify that the replacements he uses have the same safety characteristics as the original parts. Use of replacements specified by the video product manufacturer can prevent fire, electric shock or other hazards.

**20 Safety Check** -- Upon completion of any service or repairs to this video product, ask the service technician to perform safety checks recommended by the manufacturer to determine that the video product is in safe operating condition.

## VCR Customer Controls

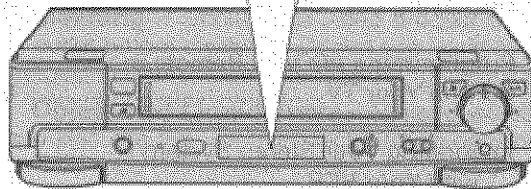
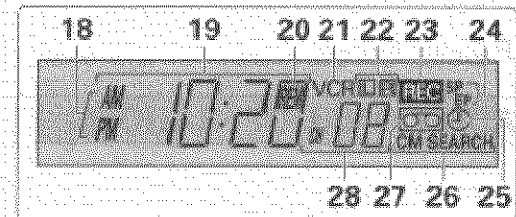
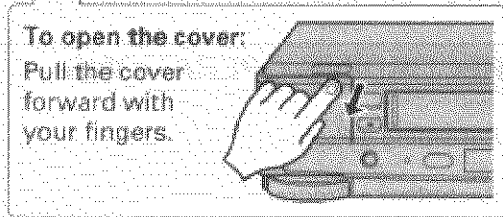
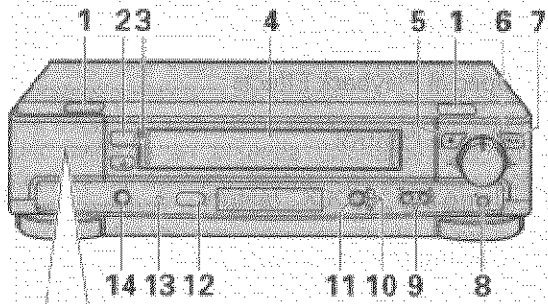

Behind the cover

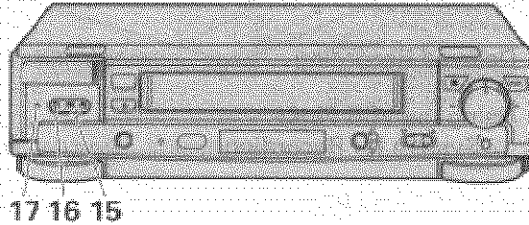

Item No.	Function	Page
1	Infrared transmitter	27
2	POWER button	2
3	EJECT button	9
4	Cassette compartment	9
5	STOP button	25
6	Shuttle ring	38
7	PLAY/STILL button	34
8	REC/IRT button	43
9	CHANNEL (channel up/down)	43
	TRACKING buttons	33
10	Select button	58
11	MENU button	32
12	Infrared receiver	8
13	REC indicator	43
14	CA SKIP button	36
15	AUDIO IN (L), (R) jacks	65
16	VIDEO IN jack	65
17	ANT. OUT select button	10
<b>VCR Display</b>		
18	AM/PM indicators	19
19	Time, Tape counter,	19 40

	Tape remaining or	40
	VCR mode indicator	32
	PLAY - playback	32
	SRCH - double-speed play	34
	and visual search ["-" appears	
	during reverse direction viewing]	
	SLOW - slow play	-
	REW - rewind	32
	FF - fast forward	-
	STILL - play pause and frame	
	advance	34
20	REM (tape remaining time)	
	indicator	40
21	VCR, operate mode	-
22	Audio indicators	-
23	REC - record (flashes during	
	record pause)	43
24	Tape speed SP/EP	43
25	Delayed recording indicator	49
26	CM SEARCH indicator	43
27	Tape-in indicator	9
28	TV channel or Auxiliary	43
	(L1/L2)	66

Click to see Accessories Supplied Illustration

## VCR Customer Controls

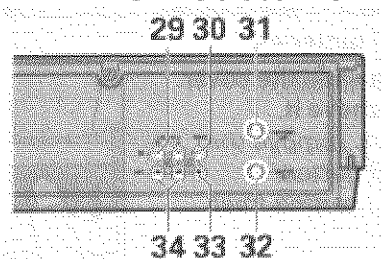

Item No.	Function	Page
29	AUDIO IN (L), (R) jacks	64
30	VIDEO IN jack	-
31	IN FROM ANT. - signal	
	input	10
32	OUT TO TV - signal to	
	TV	10
33	VIDEO OUT jack	11
34	AUDIO OUT (L), (R) jacks	11

## Remote Control Customer Controls

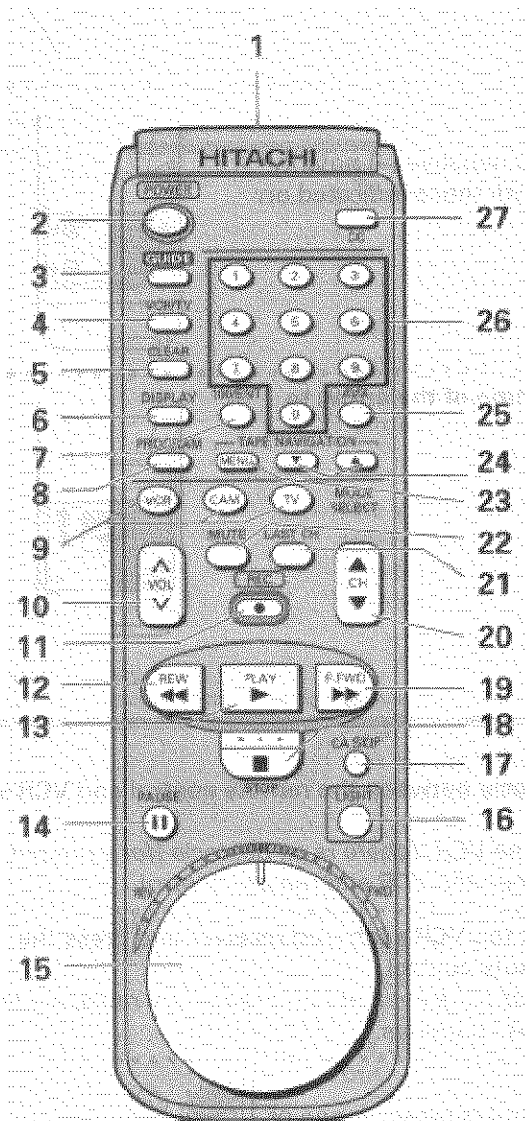

Item No.	Function	Page
1	Transmission window	8
2	POWER button	24
3	GUIDE - to recall OSD menu	24
4	VCR/TV mode select button	44
5	CLEAR - clears time counter	41
6	DISPLAY - to recall on-screen display	44
7	100/ENT button	43
8	PROGRAM (programming) button	53
9	VCR, CAM (camcorder)*, TV - device buttons let you set the remote to control one of the three devices	8
10	VOL button - increase or decrease the audio volume	63
11	REC - record button	43
12	REW button - fast rewind or search	32
13	PLAY button - playback	25

14	PAUSE button	34
15	Shuttle ring	38
16	LIGHT button - illuminates key function buttons for a few seconds	8
17	CA SKIP button	36
18	STOP button - stops play/record function	25
19	F.FWD button - fast forward or search	34
20	CH (channel up/down) button	43
21	LAST CH button - switches to the TV channel you watched previously during the current viewing session	63
22	MUTE button - turns off the audio until you press MUTE again	63
23	MENU button	32
24	SELECT button - used to select the program using Tape Navigation	58
25	AVX button - select L1 or L2	64
26	Number buttons	24
27	CC button - used to display captions on the screen	62

\* Refer to the camcorder's instruction manual for its operation.



## Install batteries in the remote control

The remote control requires two "AA" batteries.

1 Push the ▼ mark and hold it, then slide the cover in the direction of the arrow to remove it.

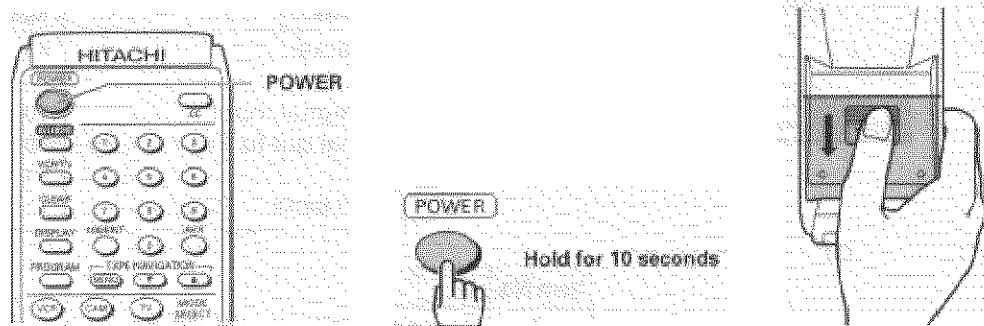

**Note:** When replacing the batteries, remove the old batteries and keep the POWER button depressed for 10 seconds before inserting fresh batteries.

### 2 Install batteries.

- Align the positive (+) and negative (-) polarity marks on the batteries with those indicated on the remote control.





**About the illuminated buttons:**

- If a button on the remote control is pressed, one of the VCR, CAM and TV buttons lights so that you know which device you are now operating.

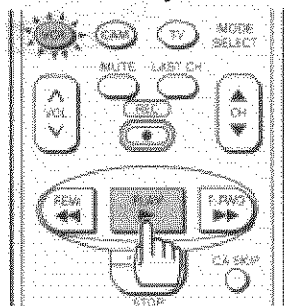

## Types

Only use video cassettes with the **VHS** mark in this VCR.



The table shows the recording time of different cassettes.

Types	Recording time	
	SP	EP
T-120	120 min.	360 min.
T-160	160 min.	480 min.
T-180	180 min.	540 min.
T-210	210 min.	630 min.

- To get the best quality picture, record at standard recording speed (SP).
- This VCR does not record at the LP speed, but it can play cassette that were recorded at the LP speed.

## Safety tabs prevent erasure

**To avoid erasing a recording**

Break off the safety tab using a screwdriver or similar tool.

**To re-record on a cassette which has its safety tab removed**

Cover the hole with plastic tape.

The VCR automatically enters the playback mode when a cassette without its safety tab is inserted. **The VCR won't record on a tape without a safety tab and the cassette will be ejected if the REC or REC/IRT button is pressed.** Be sure to check the safety tab before inserting a cassette.

## Insertion

Push the video cassette gently into the slot on the front of the VCR.

- The VCR automatically turns on and the "Tape-In" indicator  turns on when the cassette is in place.

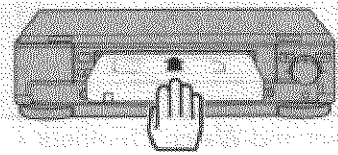

## Removal

Press the EJECT button on the VCR.

The cassette will come partially out of the compartment so you can pull it out.

- The "Tape-In" indicator  turns off.
- The cassette can be ejected with the power on or off.

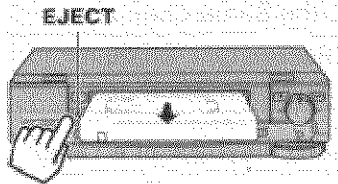

## WITH THIS HOOKUP

### YOU CAN...

- WATCH AVAILABLE TV CHANNELS
- RECORD AND WATCH THE SAME CHANNEL
- RECORD ONE CHANNEL AND WATCH ANOTHER

Hookup A Illustration

TABLE A

FUNCTION	CHANNEL SELECTION		VCR indicator (Press the VCR/TV mode select button to turn the VCR indicator on or off.)
	TV	VCR	
Select and Watch Channels using TV	Select Channel to Watch		OFF (TV mode)
Select and Watch Channels using VCR	3 or 4	Select Channel to Watch	ON (VCR mode)
Record and Watch the Same Channel	3 or 4	Select Channel to Record	ON (VCR mode)
Record One Channel Watch Another	Select Channel to Watch	Select Channel to Record	OFF (TV mode)
Watch Playback of a Tape	3 or 4		ON (VCR mode)

### Switch the RF Channel

When the VCR is on, its video signal can come into your TV on either channel 3 or channel 4. You need to select the appropriate channel.

- Turn on the power of both the TV and the VCR. Press the ANT. OUT button on front of the VCR. Pressing the button alternates between RFCH 03 (channel 3) and RFCH 04 (channel 4) in the VCR's display.

Display the channel which is not used by a commercial channel in your area.



## WITH THIS HOOKUP

**YOU CAN...**

- WATCH AVAILABLE TV CHANNELS
- RECORD AND WATCH THE SAME CHANNEL
- RECORD ONE CHANNEL AND WATCH ANOTHER

Hookup B Illustration

TABLE B			
FUNCTION	CHANNEL SELECTION		VCR indicator (Press the VCR/TV mode select button to turn the VCR indicator on or off.)
	TV	VCR	
Select and Watch Channels using TV	Select Channel to Watch		OFF (TV mode)
Select and Watch Channels using VCR	AUX or VIDEO	Select Channel to Watch	
Record and Watch the Same Channel	AUX or VIDEO	Select Channel to Record	
Record One Channel Watch Another	Select Channel to Watch	Select Channel to Record	OFF (TV mode)
Watch Playback of a Tape	AUX or VIDEO		



## WITH THIS HOOKUP

**YOU CAN...**

- WATCH AVAILABLE CABLE CHANNELS
- RECORD AND WATCH THE SAME CHANNEL
- RECORD ONE CHANNEL AND WATCH ANOTHER

Hookup C Illustration

**TABLE C**

FUNCTION	CHANNEL SELECTION		VCR indicator (Press the VCR/TV mode select button to turn the VCR indicator on or off.)
	TV	VCR	
Select and Watch Cable Channels using TV	Select Channel to Watch		OFF (TV mode)
Select and Watch Cable Channels using VCR	3 or 4	Select Channel to Watch	ON (VCR mode)
Record and Watch the Same Channel	3 or 4	Select Channel to Record	ON (VCR mode)
Record One Channel Watch Another	Select Channel to Watch	Select Channel to Record	OFF (TV mode)
Watch Playback of a Tape	3 or 4		ON (VCR mode)

**Switch the RF Channel**

When the VCR is on, its video signal can come into your TV on either channel 3 or channel 4. You need to select the appropriate channel.

- Turn on the power of both the TV and the VCR. Press the ANT. OUT button on front of the VCR. Pressing the button alternates between RFCH 03 (channel 3) and RFCH 04 (channel 4) in the VCR's display. Display the channel which is not used by a commercial channel in your area.



**WITH THIS HOOKUP**

**YOU CAN...**

- WATCH AVAILABLE CABLE CHANNELS
- RECORD AND WATCH THE SAME CHANNEL
- RECORD ONE CHANNEL AND WATCH ANOTHER

Hookup D Illustration

**TABLE D**

FUNCTION	CHANNEL SELECTION		VCR indicator (Press the VCR/TV mode select button to turn the VCR indicator on or off.)
	TV	VCR	
Select and Watch Cable Channels using TV	Select Channel to Watch		OFF (TV mode)
Select and Watch Cable Channels using VCR	AUX or VIDEO	Select Channel to Watch	
Record and Watch the Same Channel	AUX or VIDEO	Select Channel to Record	
Record One Channel Watch Another	Select Channel to Watch	Select Channel to Record	OFF (TV mode)
Watch Playback of a Tape	AUX or VIDEO		



**WITH THIS HOOKUP**

- YOU CAN...**
- WATCH AVAILABLE CABLE CHANNELS
  - RECORD AND WATCH THE SAME CHANNEL
- YOU CANT'...**
- RECORD ONE CHANNEL AND WATCH ANOTHER

ALL CHANNEL SELECTIONS MUST BE MADE AT THE CABLE BOX.  
BE SURE TO CONSULT YOUR CABLE BOX MANUAL FOR THE CABLE BOX OUTPUT CHANNEL.

Hookup E Illustration

**TABLE E**

FUNCTION	CHANNEL SELECTION			VCR indicator (Press the VCR/TV mode select button to turn the VCR indicator on or off.)
	TV	VCR	CABLE BOX	
Watch Cable Channels on TV	Select Cable Box Output Channel		Select Channel to Watch	OFF (TV mode)
Select and Watch Cable Channels using VCR	3 or 4	Select Cable Box Output Channel	Select Channel to Watch	ON (VCR mode)
Record and Watch the Same Channel	3 or 4	Select Cable Box Output Channel	Select Channel to Watch	ON (VCR mode)
Record One Channel Watch Another				
Watch Playback of a Tape	3 or 4			ON (VCR mode)

**Switch the RF Channel**

When the VCR is on, its video signal can come into your TV on either channel 3 or channel 4. You need to select the appropriate channel.

- Turn on the power of both the TV and the VCR. Press the ANT. OUT button on front of the VCR. Pressing the button alternates between RFCH 03 (channel 3) and RFCH 04 (channel 4) in the VCR's display.
- Display the channel which is not used by a commercial channel in your area.



## WITH THIS HOOKUP

**YOU CAN...**

- WATCH AVAILABLE CABLE CHANNELS
- RECORD AND WATCH THE SAME CHANNEL

**YOU CANT'...**

- RECORD ONE CHANNEL AND WATCH ANOTHER

ALL CHANNEL SELECTIONS MUST BE MADE AT THE CABLE BOX.  
BE SURE TO CONSULT YOUR CABLE BOX MANUAL FOR THE CABLE BOX OUTPUT CHANNEL.

Hookup F Illustration

**TABLE F**

FUNCTION	CHANNEL SELECTION			VCR indicator (Press the VCR/TV mode select button to turn the VCR indicator on or off.)
	TV	VCR	CABLE BOX	
Watch Cable Channels on TV	Select Cable Box Output Channel		Select Channel to Watch	OFF (TV mode)
Select and Watch Cable Channels using VCR	AUX or VIDEO	Select Cable Box Output Channel	Select Channel to Watch	
Record and Watch the Same Channel	AUX or VIDEO	Select Cable Box Output Channel	Select Channel to Record	
Record One Channel Watch Another				
Watch Playback of a Tape	AUX or VIDEO			



## WITH THIS HOOKUP

**YOU CAN...**

- WATCH AVAILABLE CABLE CHANNELS
- RECORD AND WATCH THE SAME CHANNEL
- RECORD ONE CHANNEL AND WATCH ANOTHER



TO RECORD, ALL CHANNEL SELECTIONS MUST BE MADE AT THE CABLE BOX.  
 BE SURE TO CONSULT YOUR CABLE BOX MANUAL FOR THE CABLE BOX OUTPUT CHANNEL.

Hookup G Illustration

**TABLE G**

FUNCTION	CHANNEL SELECTION			VCR indicator (Press the VCR/TV mode select button to turn the VCR indicator on or off.)
	TV	VCR	CABLE BOX	
Watch Cable Channels on TV	Select Channel to Watch			OFF (TV mode)
Select and Watch Cable Channels using VCR	AUX or VIDEO	Select Cable Box Output Channel	Select Channel to Watch	
Record and Watch the Same Channel	AUX or VIDEO	Select Cable Box Output Channel	Select Channel to Watch	
Record One Channel Watch Another	Select Channel to Watch	Select Cable Box Output Channel	Select Channel to Record	OFF (TV mode)
Watch Playback of a Tape	AUX or VIDEO			



**WITH THIS HOOKUP**

**YOU CAN...**

- WATCH AVAILABLE TV OR DSS CHANNELS
- RECORD AND WATCH THE SAME CHANNEL
- RECORD ONE CHANNEL AND WATCH ANOTHER

**YOU CAN'T...**

- RECORD A CHANNEL OTHER THAN DSS AND WATCH A DSS CHANNEL

Hookup H Illustration

**Notes:**

- Your VCR cannot receive RF signals from the antenna or cable through the DSS box. Connect the antenna or cable cord to the IN FROM ANT jack of your VCR, not to the RF IN/OUT jacks of the DSS box.
- When the DSS box is connected, you cannot control the cable box from the VCR.



**TABLE H**

FUNCTION	CHANNEL SELECTION			VCR indicator (Press the VCR/TV mode select button to turn the VCR indicator on or off.)
	TV	VCR	DSS* BOX	
Select and Watch Channels using TV	Select Channel to Watch			OFF (TV mode)
Select and Watch Channels using VCR	3 or 4	Select Channel to Watch		ON (VCR mode)
Record and Watch the Same Channel	3 or 4	Select Channel to Record		ON (VCR mode)
Record One Channel Watch Another	Select Channel to Watch	Select Channel to Record		OFF (TV mode)
Record and Watch the Same DSS* Channel	3 or 4	Select L1	Select Channel to Watch/Record	ON (VCR mode)
Watch a Channel other than DSS* and Record a DSS* Channel	Select Channel to Watch	Select L1	Select Channel to Record	OFF (TV mode)
Watch Playback of a Tape	3 or 4			ON (VCR mode)

**Switch the RF Channel**

When the VCR is on, its video signal can come into your TV on either channel 3 or channel 4. You need to select the appropriate channel.

- Turn on the power of both the TV and the VCR. Press the ANT. OUT button on front of the VCR. Pressing the button alternates between RFCH 03 (channel 3) and RFCH 04 (channel 4) in the VCR's display.
- Display the channel which is not used by a commercial channel in your area.



**WITH THIS HOOKUP**

**YOU CAN...**

- WATCH AVAILABLE TV OR DSS CHANNELS
- RECORD AND WATCH THE SAME CHANNEL
- RECORD ONE CHANNEL AND WATCH ANOTHER

**YOU CANT'...**

- RECORD A CHANNEL OTHER THAN DSS AND WATCH A DSS CHANNEL

Hookup I Illustration

**Notes:**

- Your VCR cannot receive RF signals from the antenna or cable through the DSS box. Connect the antenna or cable cord to the IN FROM ANT jack of your VCR, not to the RF IN/OUT jacks of the DSS box.
- When the DSS box is connected, you cannot control the cable box from the VCR.

**TABLE I**

FUNCTION	CHANNEL SELECTION			VCR indicator (Press the VCR/TV mode select button to turn the VCR indicator on or off.)
	TV	VCR	DSS* BOX	
Select and Watch Channels using TV	Select Channel to Watch			OFF (TV mode)
Select and Watch Channels using VCR	AUX or VIDEO	Select Channel to Watch		
Record and Watch the Same Channel	AUX or VIDEO	Select Channel to Record		
Record One Channel Watch Another	Select Channel to Watch	Select Channel to Record		OFF (TV mode)
Record and Watch the Same DSS* Channel	AUX or VIDEO	Select L1	Select Channel to Watch/Record	
Watch a Channel other than DSS* and Record a DSS* Channel	Select Channel to Watch	Select L1	Select Channel to Record	OFF (TV mode)
Watch Playback of a Tape	AUX or VIDEO			



**Note:** An antenna or cable must be connected to the VCR before you begin this operation.

**Tips**

You'll need to set the clock when first hooking up your VCR, and any time the power goes out for more than 1 hour. When you first plug in the VCR or after a power outage, the clock display will read "--:--".

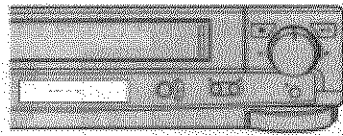

**Auto clock set function**

This function sets the VCR's clock automatically when the VCR is tuned to a station which transmits a time signal together with TV programs.

It also automatically sets the time differences between various time zones and sets the time during Daylight Saving Time (D.S.T). The auto clock set function operates each time the VCR is turned off.

- Some broadcast stations may not transmit a time signal. The auto clock set function does not operate when the VCR is tuned to a station which does not transmit a time signal. In this case, set the clock manually (See page 22).
- When the clock is set automatically, the displayed time may drift from the current time by up to one minute.

**Setting the clock automatically**

- if your VCR is hooked up to an antenna or cable without a cable box (Hookups [A], [B], [C], [D], [H] or [I])

**1 Press the POWER button to turn the VCR power off.**

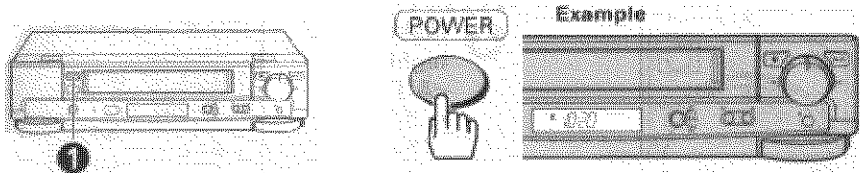

If the VCR is already turned off, press the POWER button to turn the power on, then press it again to turn the power off. The time will appear in the VCR display to show that the current time has been set. The automatic clock set procedure might take about 5 minutes.

**Notes:**

- If the clock is not set after about five minutes have elapsed, the clock must be set manually (see page 22).
- When the VCR power is restored after a power failure of more than one hour, the clock will indicate "--:--", and the clock set procedure



**If your VCR is hooked up to a cable box (Hookups [E], [F] or [G])**

**Note:** Turn on the cable box before setting.

**1 Turn on the TV and select the video channel (3 or 4).**

Or, if you are hooked up with an audio/video cable, set the TV to AUX or VIDEO.

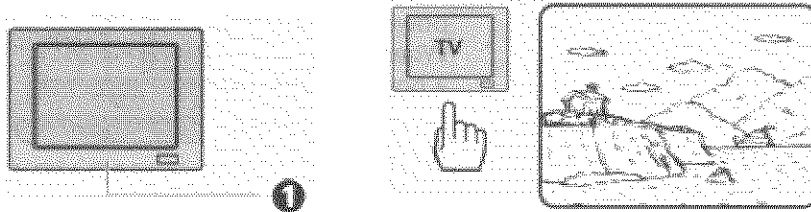

**2 Press the GUIDE button.**

The main on-screen menu will appear on the TV screen. Click to see remote control illustration.

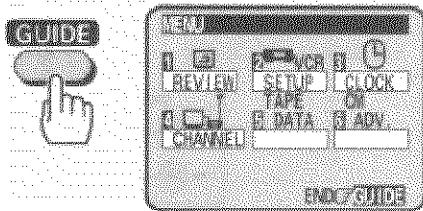

**3 Press the (3) button to bring up the CLOCK SET menu.**

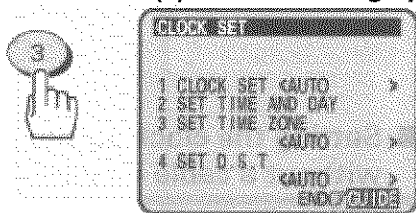

**4 Make sure that item 1 is highlighted "CLOCK SET <AUTO>".**

- If "CLOCK SET <MANUAL>" is highlighted, press the (1) button to switch it to "CLOCK SET <AUTO>".

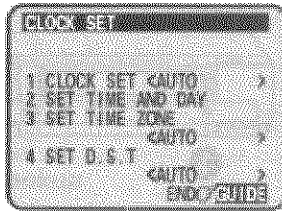

**5 Press the (2) button.**

This screen appears to show that the clock is being set.

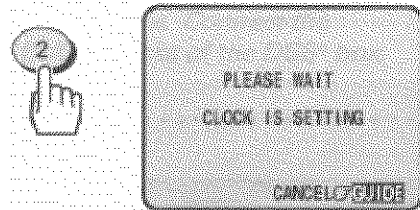

- It may take about five minutes.
- Since the VCR is searching for a broadcast station that transmits a time signal, the channel indication on the cable box changes automatically.

When the clock is set, the screen changes to a TV picture and the correct time appears in the VCR's display.

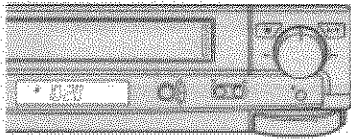

**Notes:**

- If the clock is not set after five minutes have elapsed, set the clock manually (see page 22).
- If the displayed time drifts from the current time by more than one hour, select your correct time zone and set the DST (see page 21).



**What to do if the displayed time drifts from the current time by more than an hour**

**Note:** Turn on the cable box with hookups [E], [F] or [G] before setting.

**1 Press the GUIDE button.** Click to see remote control illustration. The main on-screen menu will appear on the TV screen.

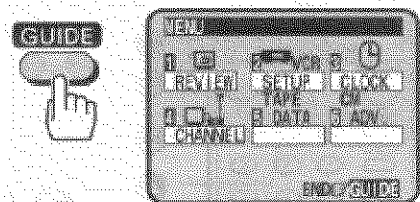

**2 Press the (3) button to bring up the "CLOCK SET" menu.** Make sure that item 1 is highlighted "CLOCK SET <AUTO>".

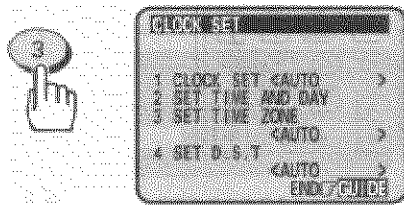

**3 Press the (3) button to select your local time zone.**

Each time (3) is pressed, the option for "SET TIME ZONE" switches from <AUTO> to <ATLANTIC>, <EASTERN>, <CENTRAL>, <MOUNTAIN>, <PACIFIC>, <ALASKA>, <HAWAII> and back to <AUTO>.

- This screen gives an example where <ATLANTIC> is specified.

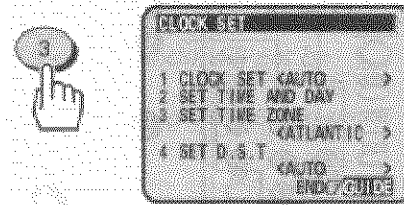

**4 Press the (4) button to select the D.S.T. option.**

Each time (4) is pressed, the option for "SET D.S.T." switches from <AUTO> to <ON>, <OFF> and back to <AUTO>.

<AUTO>: The daylight saving time (D.S.T) is set automatically.

<ON>: The time advanced from the Standard Time by one hour is displayed from the first Sunday of April through the last Sunday of October.

<OFF>: The standard time is displayed throughout the year.

- This screen gives an example where <ON> is specified.



**5 Press the (2) button to set the time.**

This screen appears to show that the clock is being set.



**Note:** If the displayed time drifts from the current time even after steps 1 - 5 have been performed, reset the DST.

Press the GUIDE and (3) buttons then press the (4) button to specify another option, then set the time again.



**To set the clock manually**

1 Press the GUIDE button.

The main on-screen menu will appear on the TV screen. Click to see remote control illustration.

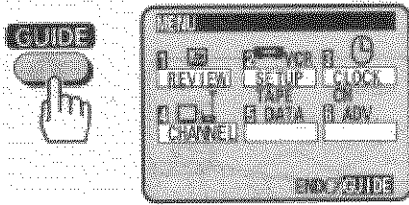

2 Press the (3) button to bring up the "CLOCK SET" menu.

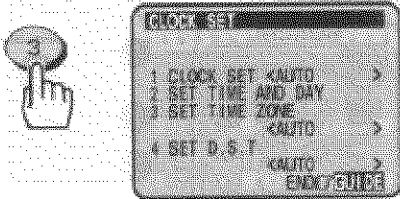

3 Press the (1) button to select "CLOCK SET <MANUAL>".

When "CLOCK SET <MANUAL>" is selected, "SET TIME ZONE" (item 3) and "SET DST" (item 4) are not displayed.

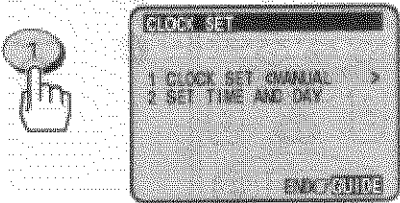

4 Press the (2) button to bring up the clock set menu.

• The white dash "-" appears for the item to be changed on the screen as you proceed.

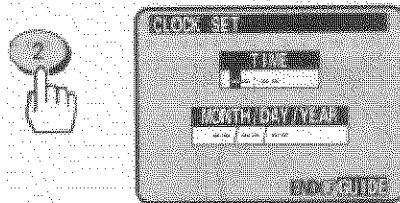

5 Press the number buttons to fill the hour and minutes. Click to see remote control illustration.

• For times with only one number (1-9) press the (0) button first, then the hour or minute. For example, if it is now 10:20AM, press (1)(0)(2)(0). "AM" and "PM" will now appear on the screen.

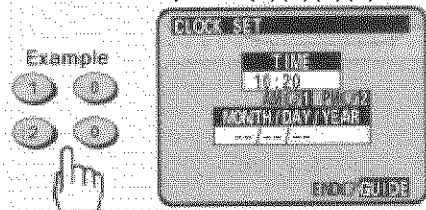

6 Press the (1) button for AM or (2) for PM.

For example, press the (1) button for AM.

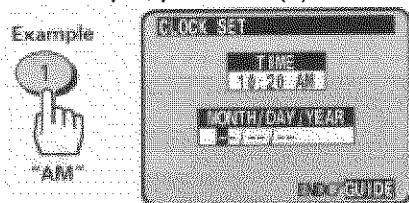

Click to see remote control illustration

**7 Press the number buttons to fill in the number of the month, then the day then the year.**

• For dates with only one number (1-9) press the (0) button first, then the date.

For example, if today is July 8 1997, press (0)(7)(0)(8)(9)(7). The correct day of the week will appear by itself.

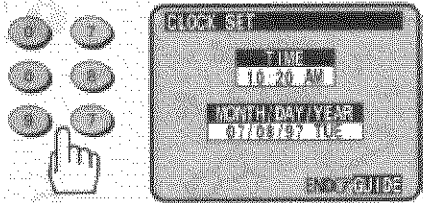

**8 Press the GUIDE button.**

The VCR clock is now set, and should show the correct time of day on the VCR's display.



**Notes:**

- The clock uses the 12-hour system. You set it for AM or PM.
- An illogical time (like 13 for the hour or 20 for the month) will not be accepted.
- If you press the wrong digit, exit the screen by pressing GUIDE and recall the screen to enter the correct setup.

**Note:** An antenna or cable must be connected to the VCR before you begin this operation.

## Presetting the received channels without using a cable box (Hookups [A], [B], [C] or [D])

**1 Press the POWER button to turn on the VCR.**

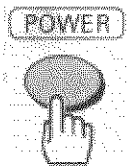

**2 Turn on the TV and select the video channel (3 or 4).**

Or, if you are hooked up with an audio/video cable, set the TV to AUX or VIDEO.

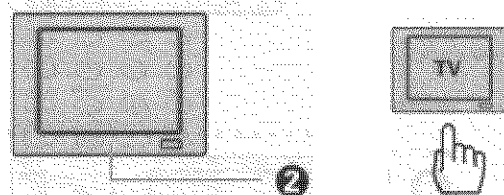

**3 Press the GUIDE button.** Click to see remote control illustration.

The main on-screen menu will appear on the TV screen.

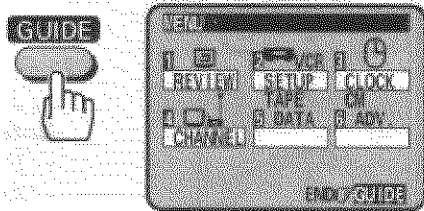

4 Press the (4) button to select the CHANNEL PRESET operation.

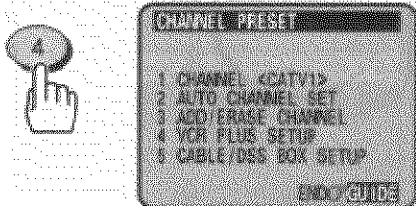

5 Press the (1) button to select the type of receiving setup you have:

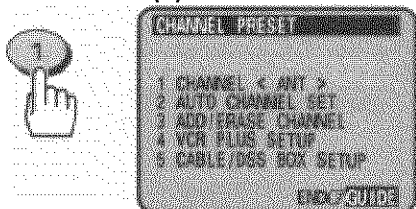

<ANT> Internal or external antenna

<CATV1> Ordinary cable

<CATV2> Alternate cable (If CATV1 doesn't give you the channels you expect).

6 Press the (2) button.

The VCR will automatically store channels received in your area. It takes about 2 - 3 minutes. After the channels are stored in memory, the channel with the lowest number appears in the VCR's display.

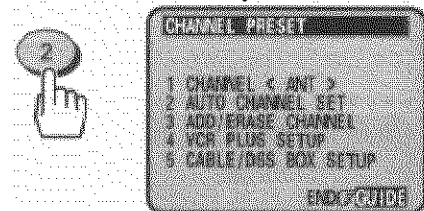

7 Press GUIDE to return to regular viewing.



## When automatic presetting of channels are finished

Press the CH (channel) button (or numbered buttons) to check the channels you can receive.

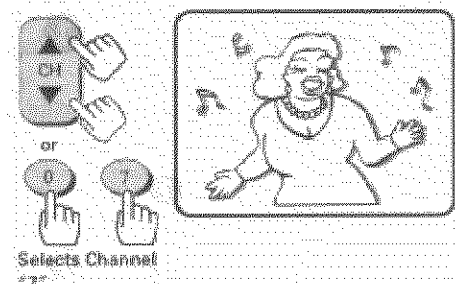



## To add or erase channels

The auto channel set procedure may memorize channels that are blank, have snowy pictures, or interference. You may skip these channels by erasing them. Very weak stations might not be memorized at all. You may receive these stations by adding them.

**1 Press the GUIDE button.** Click to see remote control illustration.  
The main on-screen menu will appear on the TV screen.

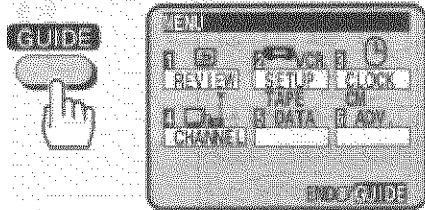

**2 Press the (4) button to select the CHANNEL PRESET operation.**

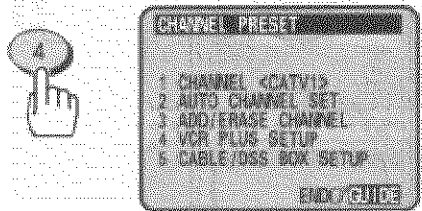

**3 Press the (3) button to select "ADD/ERASE CHANNEL".**

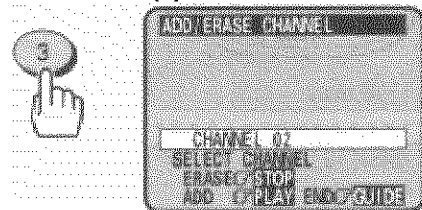

**4 Use the number buttons to select the number of the channel you want to add or erase.**

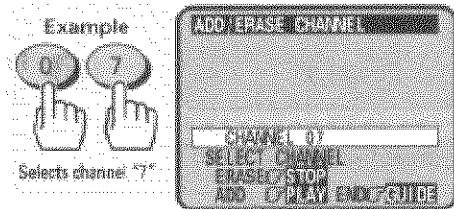

**5 Press the STOP button to delete the channel, or press the PLAY button to add it.**

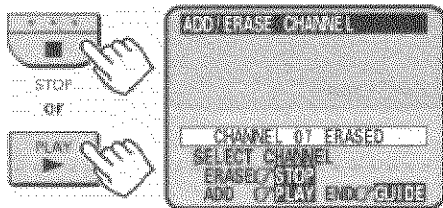

**6 Press the GUIDE button to return to regular viewing.**

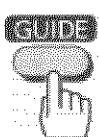

## Auto blue setting

**1 Turn on the TV and select the video channel (3 or 4).**

Or, if you are hooked up with an audio/video cable, set the TV to AUX or VIDEO.

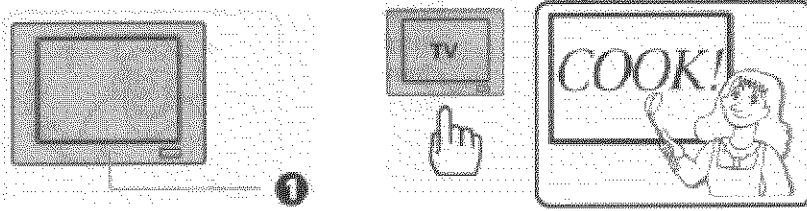

**2 Press the GUIDE button.** Click to see remote control illustration.

The main on-screen menu will appear on the TV screen.

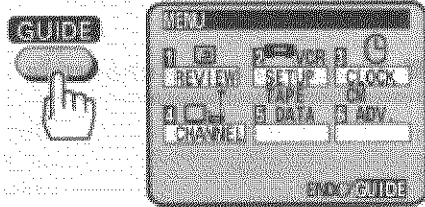

**3 Press the (2) button to select "VCR SETUP".**

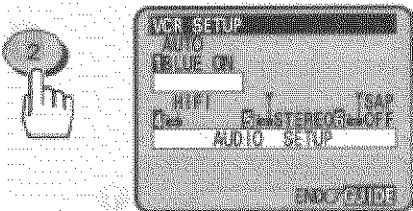

**4 Press the (1) button to select AUTO BLUE "ON" or "OFF".**

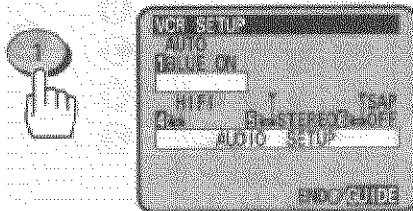

**ON:** The screen becomes blue and mutes sound when a channel without a broadcast signal on the VCR or a channel on which broadcasting has finished.

• If the signal is too strong, this function may not operate even if you specify <ON>. During playback this function does not operate.

**OFF:** The AUTO BLUE feature is switched off.

**5 Press the GUIDE button to end the setting.**



**Note:** This setup should be performed if you receive all channels through a cable box (Hookups [E], [F] or [G]).

**The VCR can be programmed to:**

Automatically select channels on the cable box during a timer record or VCR Plus+ delayed recording operation. Change channels on remote controlled cable boxes with the VCR remote control.

**BEFORE YOU BEGIN...**

Make sure the cable box is positioned properly on the VCR.

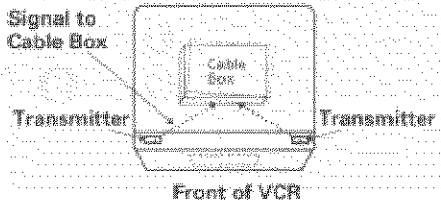

**1 Turn on the TV and select the video channel (3 or 4).**

Or, if you are hooked up with an audio/video cable, set the TV to AUX or VIDEO.

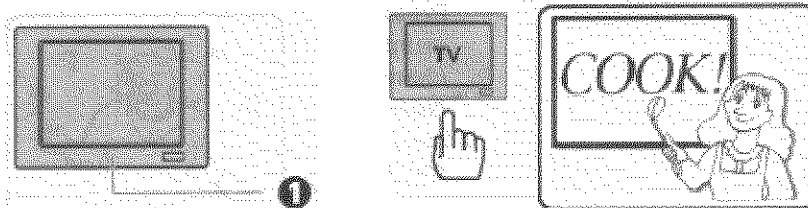

**2 Press the GUIDE button.** Click to see remote control illustration.

The main on-screen menu will appear on the TV screen.

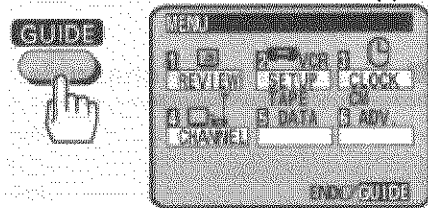

**3 Press the (4) button to select the CHANNEL PRESET operation.**

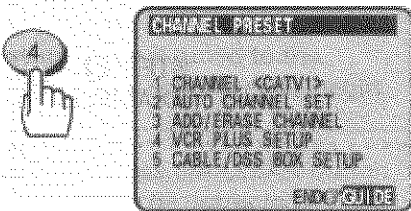

**4 Press the (5) button to select "CABLE/DSS BOX SETUP" menu.**

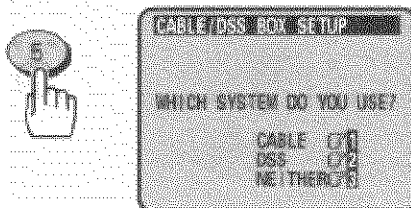

**5 Press the (1) button to answer "CABLE" to the question "WHICH SYSTEM DO YOU USE?"**

• Press the (3) button for normal TV viewing. Also press (3) to release the CABLE BOX or DSS BOX setting after you have set it up.

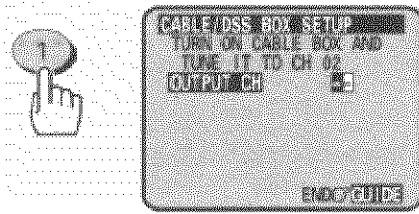

**6 Turn on your cable box and select channel 2.**

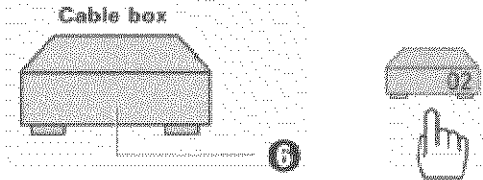

**Note:** Refer to the cable box owner's manual to identify the cable box output channel (usually 3 or 4).

**7 Using the VCR remote, enter the cable box output channel numbers.** Click to see remote control illustration.

For example, press (0)(3) for channel 3.

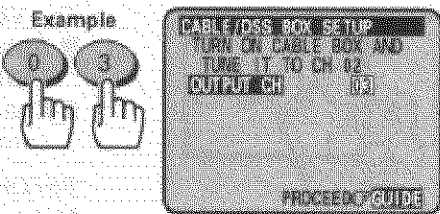

**8 Press the GUIDE button to enter the output channel of your cable box.**

- The CABLE BOX TYPE message will appear on the TV screen.

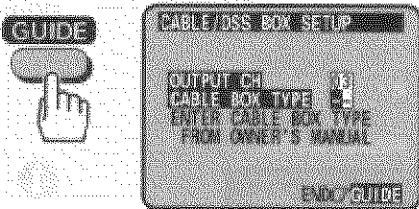

**9 Press the two number buttons that match the code number of your cable box brand from the table below.**

For example, press (3)(7) for the Hitachi brand cable box.

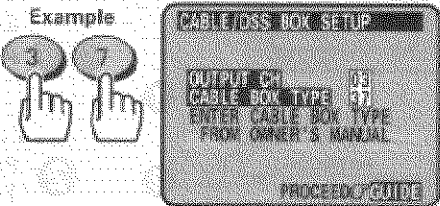

**STEP 9  
EXAMPLE**

Brand	Code Number(s)	Brand	Code Number(s)	Brand	Code Number(s)
Anvision	07, 08	NSC	08, 59	Scientific Atlanta	03, 22, 35
Cablestar	07, 08	Oak	01, 16, 29, 38	SL Marx	15, 18, 31, 38, 44, 53
Eagle	07, 08, 19, 26, 28, 32, 40, 41, 60	Oak Sigma	16	Stargate	15, 18, 31, 38, 44, 53
Eastern International	02	Panasonic	03, 27, 39, 44	Sylvania	11
GE	56	Philips		Teknika	05
General Instrument	04, 05, 15, 23, 24, 25, 30, 36, 55, 61		07, 08, 19, 26, 28, 29, 32, 33, 40	Teleview	15, 18, 31, 38, 44, 53, 59
Hamlin	12, 13, 34, 48, 58	#1		Texscan	10, 11
Hitachi	37, 43	Pioneer	18, 29, 44	Tocom	17, 21, 49, 50, 54, 57, 61
Jenolud	04, 05, 15, 23, 24, 25, 30, 36, 45, 46, 47, 55, 61	Pulser	31, 53	Unika	37, 32, 41, 53
Macom	37, 43	Randtek	07, 08	Universal	51, 52
Magnavox	07, 08, 19, 26, 28, 29, 32, 33, 40, 41	RCA	00, 27, 39, 44	Viewstar	07, 08, 19, 26, 28, 29, 32, 33, 40, 41, 59, 60
Movietime	09, 59	Regal	12, 13, 19, 40, 56	Warner Amex	44
GC Electronics	31, 53	Regency	02, 33	Zenith	14, 42
		Rembrandt	53		
		Samsung	15, 18, 27, 36, 39, 44, 53		

**10 Press the GUIDE button to enter your cable box brand.**

The VCR will change the cable box from channel 02 to channel 09 to confirm that the correct code was entered.

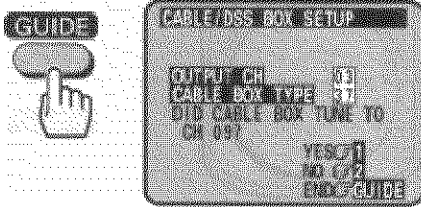

**11 Cable box channel changed to channel 9: Press the (1) button to end this setting.** Click to see remote control illustration.

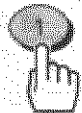

Your cable box and VCR are now set for VCR Plus+ program recording. Depending on the manufacturer and model of the cable box, you may also be able to use the VCR remote control to:

- Change channels on the cable box with the remote's channel Up/Down buttons.
- Use the numbers on the VCR remote to select cable box channels directly.

**Note:** Only the cable box will change channels. The VCR channel will not change.

Cable box did not tune to channel 9: Press the (2) button to return to step 9, and enter a different code number.

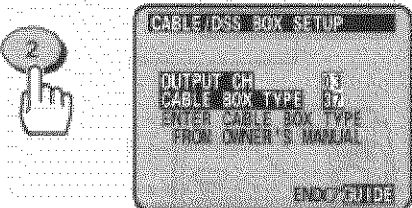

**If the codes you entered do not work:**

- Try repositioning the cable box on top of the VCR and reentering the codes.
- Try entering all code numbers (00 - 61). Press number buttons to enter another code number.

If none of the codes work, press the GUIDE button to quit. The VCR will not control your cable box. However, the output channel of the cable box has been set. Turn on the cable box and leave it tuned to the channel you want to record before the recording is scheduled to begin.

**Note:** If you make a mistake when entering digits, press the CLEAR button repeatedly to return the white dash "-" to the digit to be corrected. Then, punch in the correct number.

**Note:** Connect a DSS box to your VCR.

## (Hookups [H] or [I].)

The VCR can be programmed to:

Automatically select channels on the DSS box during a timer recording operation.

### BEFORE YOU BEGIN...

Make sure the DSS box is positioned properly on the VCR.

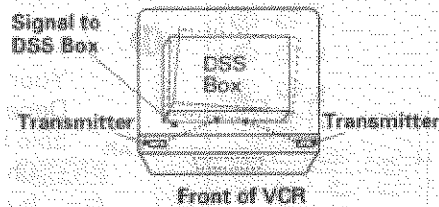

### 1 Turn on the TV and select the video channel (3 or 4).

Or, if you are hooked up with an audio/video cable, set the TV to AUX or VIDEO.

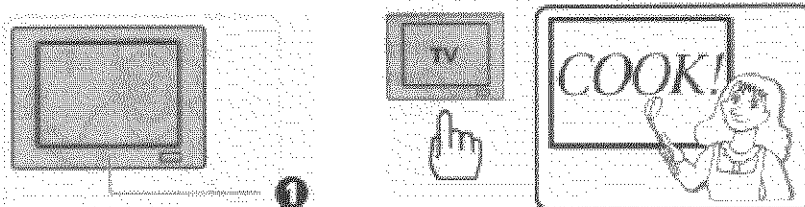

### 2 Press the **GUIDE** button. Click to see remote control illustration.

The main on-screen menu will appear on the TV screen.

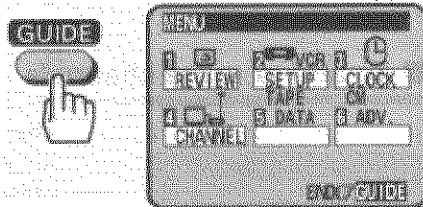

### 3 Press the (4) button to select the **CHANNEL PRESET** operation.

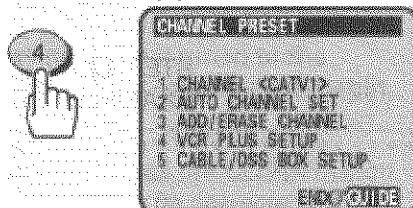

### 4 Press the (5) button to select "CABLE/DSS BOX SETUP" menu.

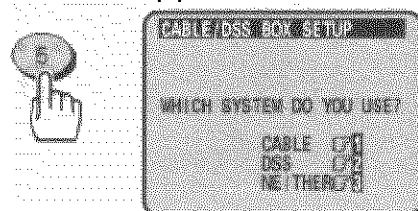

**5 Press the (2) button to answer "DSS" to the question "WHICH SYSTEM DO YOU USE?"**

- Press the (3) button for normal TV viewing. Also press (3) to release the CABLE BOX or DSS BOX setting after you have set it up.

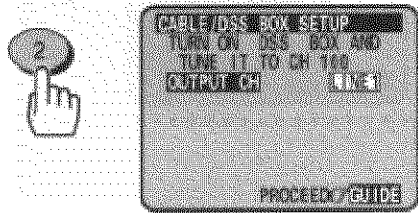

**6 Turn on your DSS box and select channel 100.**

- The output channel of the DSS box will be set to LINE 1 (L1) automatically.

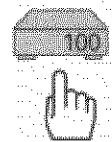

**7 Press the GUIDE button to display the DSS BOX TYPE message on the TV screen. Click to see remote control illustration.**

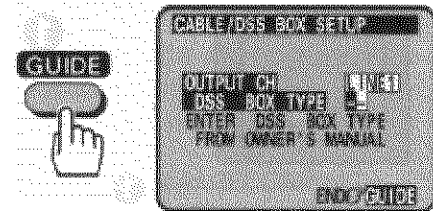

**8 Press the two number buttons that match the code number of your DSS box brand from the table below.**

For example, press (0)(1) for the Hitachi brand DSS box.

Example

Brand	Code Number(s)
RCA	00
Hitachi	01, 02
Hughes	01, 02
Sony	03

**9 Press the GUIDE button to enter your DSS box brand.**

The VCR will change the DSS box from channel 100 to channel 999 to confirm that the correct code was entered.

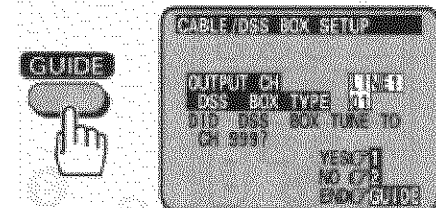

**10 DSS box channel changed to channel 999: Press the (1) button to end this setting.**

Your DSS box and VCR are now set for DSS program recording.



**DSS box did not tune to channel 999: Press the (2) button to return to step 8, and enter a different code number.**

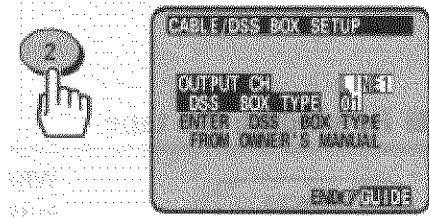

**If the codes you entered do not work;**

- Try repositioning the DSS box on top of the VCR and reentering the codes.
  - Try entering all code numbers (00 - 03). Press the number button to enter another code number.
- If none of the codes work, press the GUIDE button to quit. The VCR will not control your DSS box. If you wish to program a DSS broadcast for delayed recording, press the AVX button to select "LINE 1" instead of selecting a recording channel by the ordinary programming procedure. Turn on the DSS box and leave it tuned to the channel you want to record before the recording is scheduled to begin.

**Note:** If you make a mistake when entering digit, press the CLEAR button repeatedly to return the white dash "-" to the digit to be corrected. Then, punch in the correct number.



## To playback a recorded tape

**1 Turn on the TV and select the video channel (3 or 4).**

Or, if you are hooked up with an audio/video cable, set the TV to AUX or VIDEO.

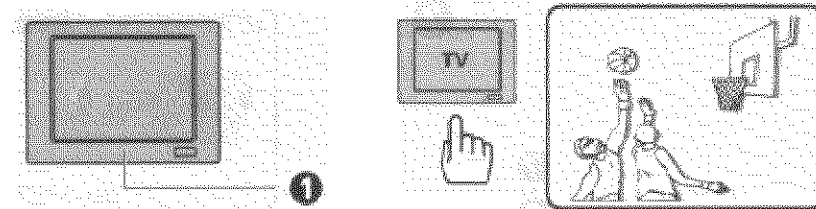

**2 Insert a recorded tape.**

The power comes on automatically and the tape indicator lights on the display.

- When a cassette without its safety tab is inserted, playback starts automatically.

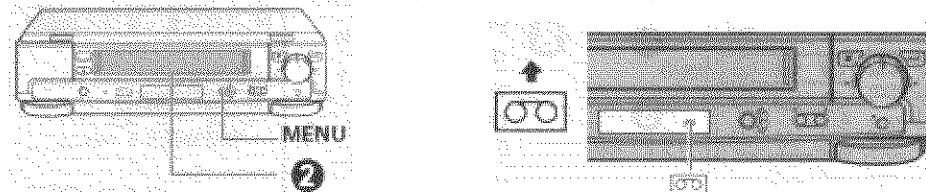

- When a tape is inserted the Tape Navigation function may operate and "120" display may flash after the MENU button indicator on the VCR flashes. Ignore this display as this has nothing to do with tape play. This display will disappear after about 10 seconds.

**3 Press the PLAY button to start playing the tape.** Click to see remote control illustration.



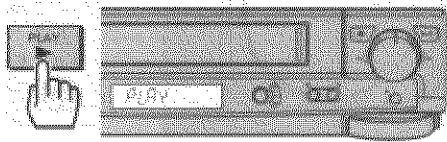

**4 Press the STOP button to end playback.**

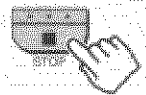

## Rewinding the tape

**When the video cassette reaches the end of the tape, the VCR will stop automatically and rewind the tape.**

- If you press the POWER button while the tape is rewinding, the power will not shut off until the tape has been completely rewound.

You may also rewind the tape manually at any time.

### Manual Rewind

**1 Press the STOP button to end playback.** Click to see remote control illustration.

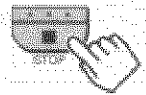

**2 Press the REW button.**

The VCR rewinds the tape all the way to the beginning, then stops.

- Press the EJECT button on the VCR to eject the tape.



## Rewinding the tape

### Movie Return

If your videocassette has the safety tab removed, the VCR will stop and automatically rewind the videocassette, eject it, and turn off the power when it reaches the end of the tape or a blank section of tape which lasts for more than 30 seconds.

**Note:** This function works only in PLAYBACK mode, not in RECORDING mode.

## To remove noise from the picture

### Auto Tracking

Pressing the PLAY button starts the auto tracking feature, which automatically adjusts playback to eliminate static lines or picture noise that may appear on the screen.

### Manual Tracking

Scratched tapes or poorly recorded tapes may require additional picture adjustment. You can do this with the remote control.

**Note:** To reactivate auto tracking, simply eject the tape and reinsert it into the VCR.

**1 Press the CH (▲ or ▼) button on the remote control or TRACKING button on the VCR when viewing a cassette.**



Press either the ▲ or ▼ buttons until picture is clear.

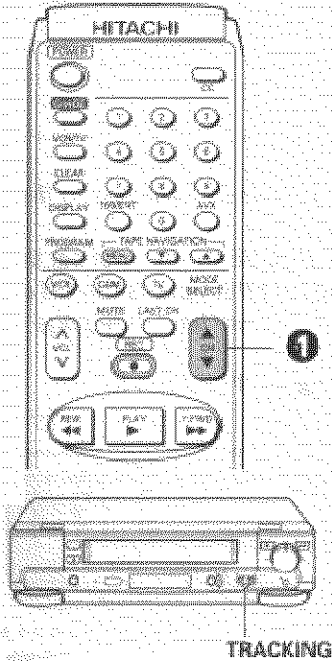

## Variable speed playback

### Still Playback (Pause)

Press the PAUSE button on the remote control or PLAY/STILL on the VCR to still the tape during play.

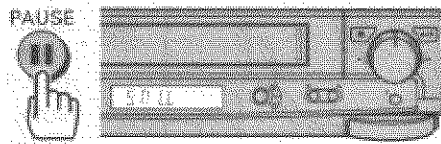

The picture will "freeze". You may see some minor noise or interference on the screen. This is normal.

- To resume play, press the PLAY button or PAUSE (PLAY/STILL) button again.

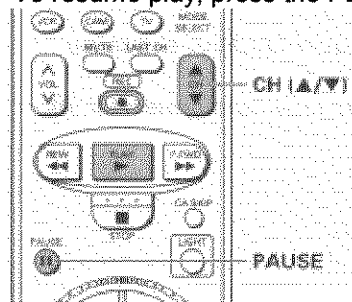

**Note:** The sound is muted and cannot be heard during "Special Playback Effects".

**Notes:**

- After 1 minute in the PAUSE mode, the VCR automatically switches to STOP mode to protect the tape.
- If noise bars appear on the TV screen during the PAUSE mode, first set the VCR to the SLOW mode by using the shuttle ring and then press the CH (▲ or ▼) button on the remote control to minimize the noise bars (see page 38).
- If the screen jitters during PAUSE, press the CH (▲ or ▼) button to minimize the jitter.

### Frame Advance

**1 Press the PAUSE button to stop the tape during playback.**



**2 Press the CA SKIP button to view the picture one frame at a time.**

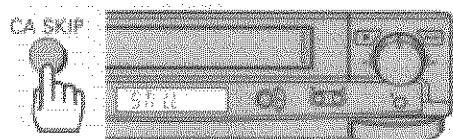

- Press the PAUSE button to resume play.

### Visual Search

This function let you search backward and forward through the videotape while viewing it.

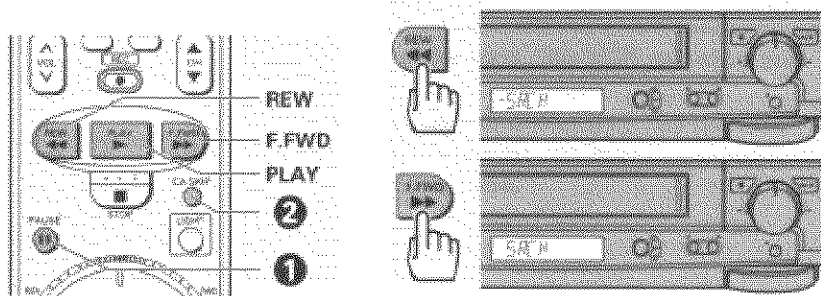

**During play:**

**Press the REW button to search in reverse.**

**Press the F.FWD button to search ahead.**

- Press the PLAY button to return to normal playback.

**Press REW or F.FWD and hold it; you can search backward or forward through the tape at a higher speed while viewing it.**

- Press PLAY and REW, then hold REW for backward search at a higher speed.
- Press PLAY and F.FWD, then hold F.FWD for forward search at a higher speed.
- Release REW or F.FWD to return to normal playback.

## Choosing a mode for audio playback

The VCR records the same audio on both the Hi-Fi and linear tracks on the tape. The Hi-Fi sound is recorded on separate left and right stereo channels. Monaural sound is recorded on the linear track.

To enjoy Hi-Fi sound, connect your VCR to a stereo television or amplifier/receiver using the audio/video jacks (see page 64).

### How to select playback audio

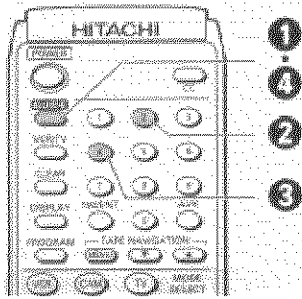

1 Press the **GUIDE** button.



2 Press the **(2)** button to select the **VCR SETUP** operation.

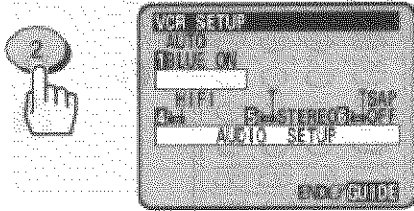

3 Press the **(4)** button to select **"HIFI"** or **"LINEAR"**.

- Select **Hi-Fi** to playback sound recorded on the Hi-Fi track and for normal use. The **L** and **R** indicators will light in the VCR's display panel.
- Select **LINEAR** to play back the sound recorded on the linear monaural track. Also, if the audio sounds distorted or unusual or there is no audio, select **LINEAR**.

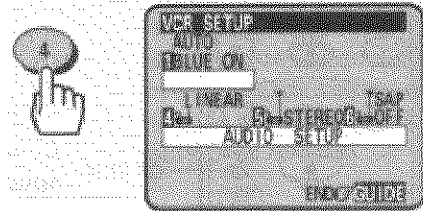

4 Press the **GUIDE** button to end the setting.



#### **COMMERCIAL → ADVANCE™ (CA SKIP)**

"Commercial Advance™ is a trademark of Arthur D. Little Enterprises.  
A Jerry Iggulden invention licensed by Arthur D. Little Enterprises."

With Commercial Advance, the VCR detects commercials on the recorded tape and marks them, they can then be skipped when the tape is played back. This function can operate with a tape on which a program lasting for more than 15 minutes has been recorded. Using this function you can select whether the commercials are to be skipped automatically or manually by operating buttons and you can also select whether the TV screen becomes blue or the commercials are played in the forward search mode when they are being skipped. After a recording is finished, the VCR rewinds the tape to the commercials and marks them. After marking the commercials, the VCR fast forward the tape to the end of the recording.

**Note:** This function does not erase the commercials from the tape.

Refer to the following for details.

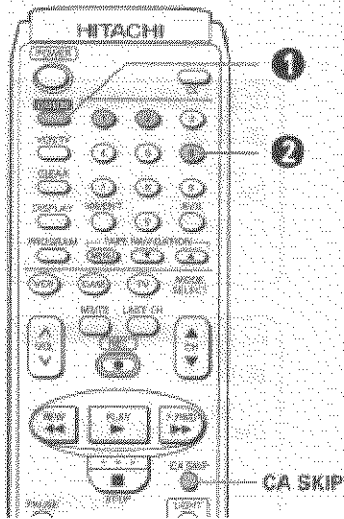

1 Press the **GUIDE** button. The main on-screen menu will appear on the TV screen.



2 Press the **(6)** button to select "CM ADV."  
The "COMMERCIAL ADVANCE" menu will appear on the TV screen.

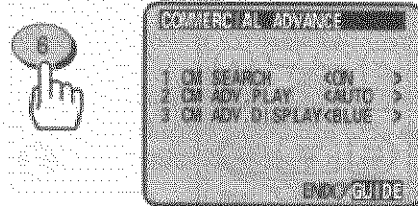

**Commercial Advance Marking:**

Confirm that "CM SEARCH <ON>" is specified for item 1. If not, press the **(1)** button.

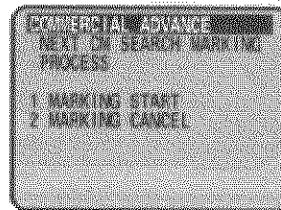
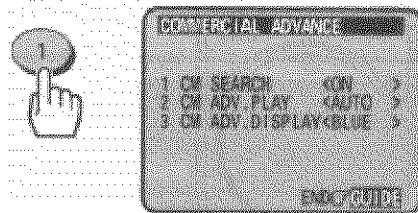

The screen on the right appears each time you stop recording.

Select 1 or 2 within one minute after this screen has appeared. If it is not selected within one minute, the menu will disappear and "1 MARKING START" will be selected. If the recording includes commercials, the tape is rewind automatically and the commercials are marked when the button is pressed. Press the (2) button to cancel the markings.

After you have made a delayed recording, "1 MARKING START" is specified automatically.

**To Turn Off Marking:**

Press the **(1)** button to select "CM SEARCH <OFF>".

The VCR will not mark commercials.

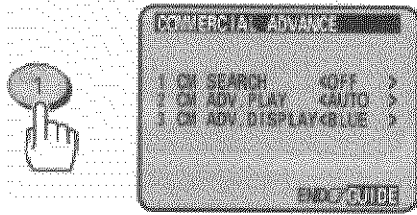

To play back tapes recorded using Commercial Advance:  
Press the (2) button to select <AUTO> or <MANUAL>.

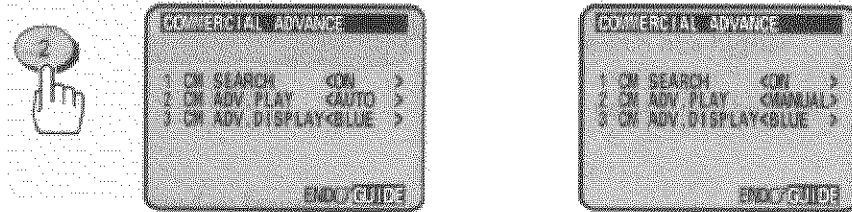

Select <AUTO> to play the marked commercials in the forward search mode automatically.  
Select <MANUAL> if you don't want to play the commercials in the forward search mode. If <MANUAL> is specified, the marked commercials are played in the forward search mode only when the CA SKIP button on the remote control is pressed.

To select a background for playback:  
Press the (3) button to select <VIDEO> or <BLUE>.



Select <BLUE> if you want the screen to become blue when the commercials are being skipped.  
Select <VIDEO> if you want to play the commercials in the forward search mode when they are being skipped.

3 Press the **GUIDE** button to end the setting.

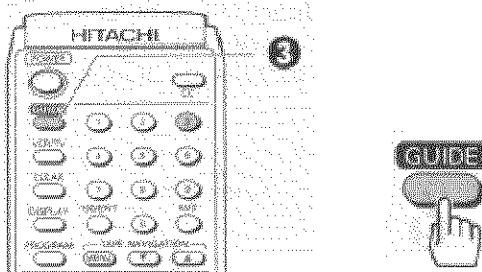

"This product incorporates Commercial Advance circuitry that eliminates most commercial messages during replay of a recorded television broadcast. Under controlled test conditions with major network daytime and prime time broadcasts, approximately 96% of intraprogram commercials are eliminated.  
\* Actual test results may vary and will depend upon the quality of television reception and the nature of programming recorded."

\* For a copy of the complete test report please write to:

Arthur D. Little Enterprises  
Acorn Park  
Cambridge, MA 02140-2390 USA

**Note:** If a power failure has occurred during recording, CM SEARCH will not be performed precisely.

## Precautions

### Position of tape after commercials were marked:

After marking commercials, the VCR fast forwards the tape to the end of recording to be ready for the next recording.

### If two or more programs were recorded continuously:

If there is not time for marking the tape the recording of which has finished, the commercials will be marked when all recordings are finished.

### If the recording speed is changed:

Commercial Advance will operate with recordings at any speed.

### If a tape marked using Commercial Advance is played back by another VCR which does not have Commercial Advance:

The tape can be played back, of course, but the commercials cannot be skipped automatically.

## Markings after delayed recording is finished

After one delayed recording is finished, if it is 99 minutes or less until the next delayed recording starts, the commercials will be marked after the other delayed recording has finished. "CM SEARCH" lights in the VCR display until the next delayed recording starts. Do not perform eject, play, fast forward or rewind while "CM SEARCH" is displayed. If you do, "CM SEARCH" will turn off and marking will be cancelled (marking will not be done).

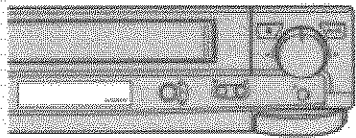

## Using the shuttle ring on the remote control

The shuttle feature lets you control all the playback functions - PLAY, PAUSE, SLOW MOTION, and SEARCH - using one convenient ring.

If the shuttle ring is operated when the key function buttons are illuminated, the illumination goes off.

### How to use the shuttle ring

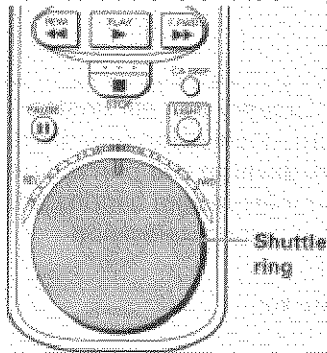

### [A] Turn the shuttle ring during playback or still playback (pause).

- As you turn the ring, you get different playback speeds and forward or reverse motion.
- Try using the shuttle to explore backward and forward through your next video.

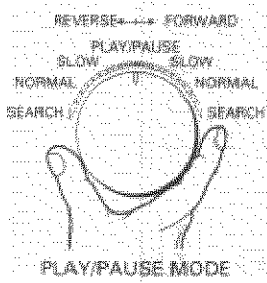

**[B] Turn the ring in the stop mode to fast forward or rewind the tape.**

- The tape continues to be wound even after you release the dial.

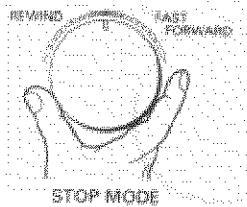

**Note:**

- If noise bars appear on the TV screen during the **SLOW/STILL** modes, turn and hold the shuttle ring in the **SLOW** position, then press the CH (▲ or ▼) button on the remote control to minimize the noise bars. The noise bars are then eliminated automatically in the **STILL** mode.
- Since thin videotape is used in T-180 and longer cassettes, do not repeatedly perform the following operations with these tapes.
  - Fast forward, rewind, slow play
  - Insertion and ejection of tapes



**To find specific sections on a tape using the "INDEX" feature**

**Jump to an Index Mark with INDEX**

A quick way to access specific program segments is with the index search feature. This lets you move through a tape that has several recordings on it by searching for the INDEX "mark". This function only works with recordings that have been set up with indexing. You create an INDEX mark (VISS signal) every time you pres the REC or REC/IRT button while recording.

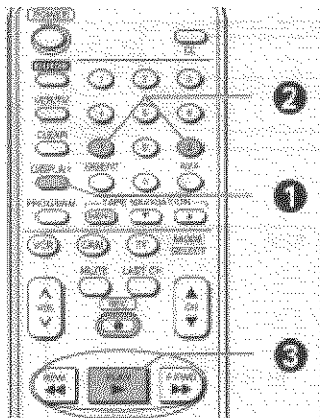

**1 Press the DISPLAY button in the stop mode.**



The index screen appears on TV.

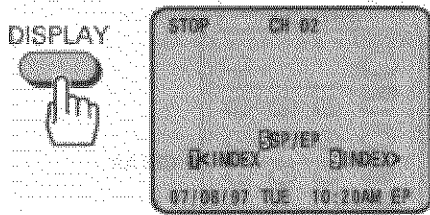

2 Press the (7) button for rewind or the (9) button for forward to begin the index search.

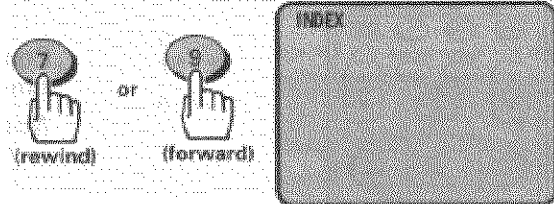

- The tape rewinds or fast forwards until an index mark is detected. During this search, the word INDEX is displayed at the top left corner of the screen.
- When the VCR finds an index mark, it plays 15 seconds of the program that begins at that spot.

3 If this is the program you were looking for, press the PLAY button for normal playback.

- To stop the index search before an index mark is reached, press the STOP button.

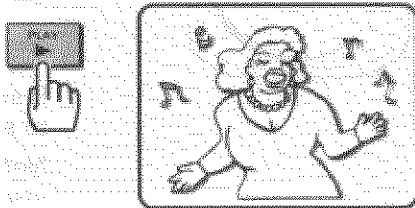

**Note:** If there are no index marks on the tape, the VCR will just rewind to the beginning or fast forward to the end.

## Switching between the clock, time counter and time of remaining tape

Press DISPLAY while the on-screen display is displayed. The on-screen display switches in the order below together with the VCR's display.

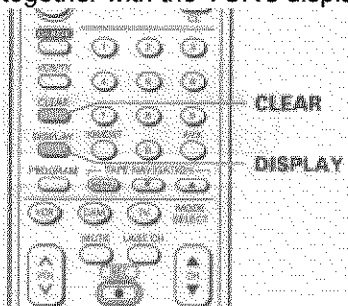

Click to see on-screen and VCR displays

Press the DISPLAY button to see the clock.

Press the DISPLAY button a second time to see just the time counter.

**Notes:**

- The linear time counter operates only if there is something recorded on the tape.
- The counter changes to 0:00:00 when the tape is ejected.

Press the DISPLAY button a third time to see the tape remaining time.

**Note:** Immediately after the tape is inserted, "--:--" will appear.

2 minutes after playback or recording is started, the tape remaining time is displayed.

Press the CLEAR button repeatedly to switch the type of the tape used. The correct remaining time will appear.

AUTO: T-120 or shorter tape

T-160: T-140 or T-160 tape

T-180: T-180 tape

T-210: T-210 tape

**Notes:**

- The tape remaining time is not displayed correctly for a tape without any recordings or tapes other than T-30/60/90/120/140/160/180/210.
- The remaining time may not be displayed correctly during fast forwarding or rewinding.



## To find specific sections on a tape

### Indexing with the Time Counter

You can set the time counter to memorize a certain point in the video programming, and you can return to that point automatically.

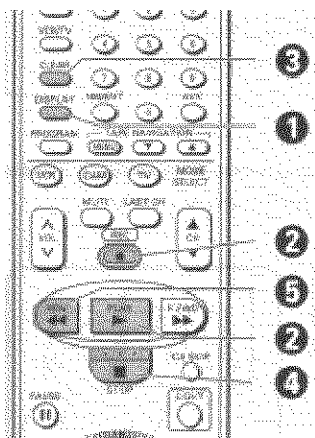

**1 Press the DISPLAY button two or three times.**

The counter will appear in the VCR's display.



**2 Begin recording or playing back a tape.**

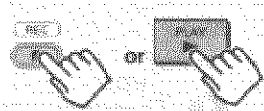

**3 At the point that you want to go back to, press the CLEAR button.**  
This resets the counter to 0:00:00.

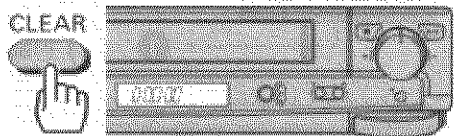

**4 Press the STOP button when you are done recording or playing back the tape.**

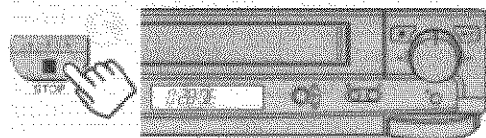

**5 Press the REW button to rewind the tape.**



It will automatically stop at the stop where you cleared the counter in step 3.  
• Press the PLAY button to watch the tape from the selected spot.

**Note:** Press the DISPLAY button to turn the counter display off. The selected spot will stay in memory until you set a new one or until the tape is ejected.



## Before you record

**Note:** The cassette safety tab must be in place in order to record.

To re-record on a cassette which has its safety tab removed.

Cover the hole with cellophane tape.

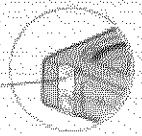

The VCR must be hooked up properly for recording. See the Simple Hookups at the beginning of this manual.

### Copyright infringement warning

Most television programs and films are copyrighted. This means that someone has legal rights governing the reproduction and distribution of this material. In certain circumstances, copyright law may apply to private in-home taping of copyrighted materials. In most cases, it is okay to record for personal use, as long as you do not sell the material. You must act responsibly in this area - check into the matter if you are unsure.

## Basic recording steps

**Note:** You may use a blank tape or you may record over a previously recorded (erasable) tape.

### 1 Turn on TV and select the video channel (3 or 4).

Or, if you are hooked up with an audio/video cable, set the TV to AUX or VIDEO.

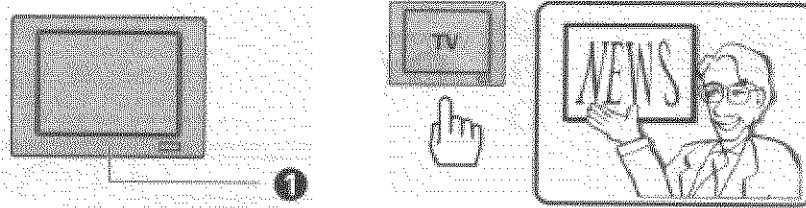

### 2 Insert a blank or erasable tape.

The power comes on automatically and the tape indicator lights on the display.

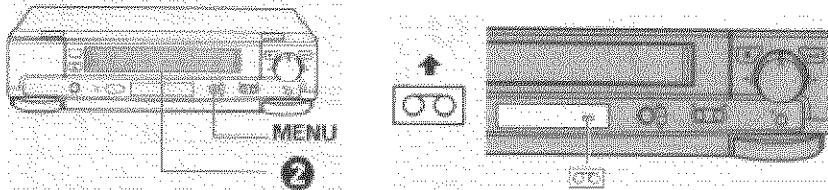

- If a cassette without its safety tab is inserted, playback starts automatically, and you cannot complete the record operation.

When you insert a blank tape (or a tape recorded without "Tape Navigation" indexing), the MENU button indicator on the VCR flashes and "120" flashes in the VCR's display for about 10 seconds.

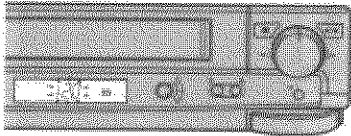

- If you are using a T-120 tape for recording: Ignore this display.
- If you are using a T-140, T-160, T-180 or T-210 tape for recording: Refer to "Storing tape data in memory" on page 57.
- While the **MENU** button is flashing, a recording cannot be made even if the **REC** button is pressed.

### 3 Press the DISPLAY button.

This screen appears on the TV.

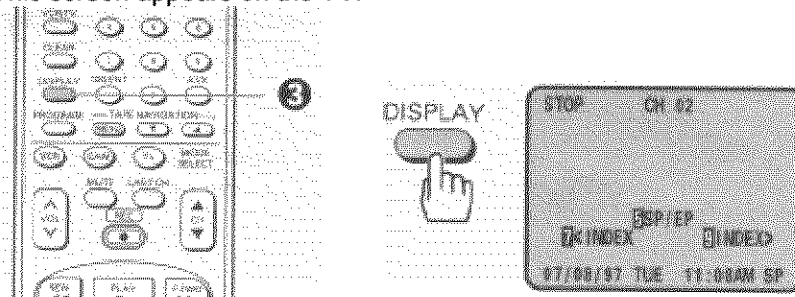

4 Press (5) button to select SP (standard play, for the best picture quality) or EP (extended play, for the longest recording time on a single tape).

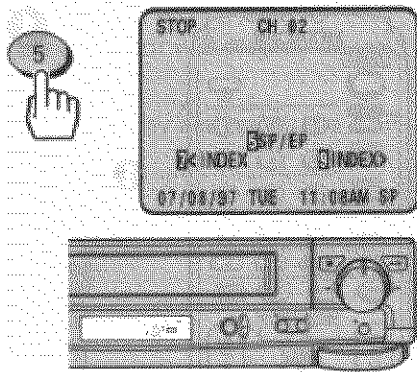

- An indicator on the VCR's display shows which speed is selected.

**5 Press the CH (▲/▼) button or the number buttons to select the channel you want to record.**  
**Example: Select channel 8.**

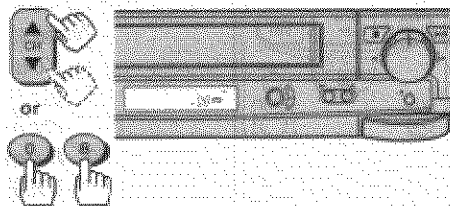
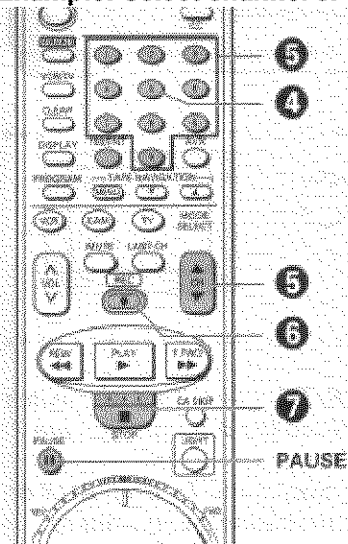

- 100/ENT and (2) and (4) for channel 124.

**6 Press the REC button on the remote control or the REC/IRT button on the VCR.**

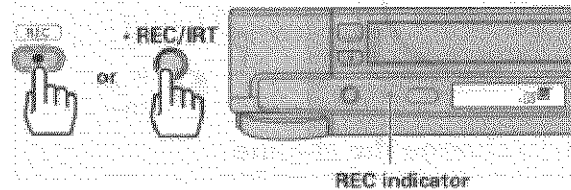
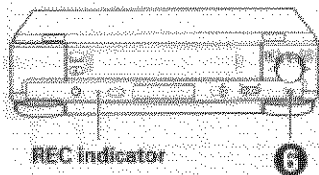

Recording will start and the REC indicator on the VCR will light red.

**Notes:**

- Recording will not start unless the cassette has the safety tab in place. If this tab has been removed, the VCR will eject the tape.
- Press the PAUSE button to set the VCR to the recording pause mode. Press the button again to re-start recording.
- If you stay in PAUSE mode for more than 5 minutes, the VCR automatically switches to STOP mode to protect the tape.

**7 Press the STOP button to finish recording.**

The commercial advance function setting screen will appear.

Select 1 or 2 within one minute after this screen has appeared. If it is not selected within one minute, the menu will disappear and "1 MARKING START" will be selected.

- When you press the (1) button and if the recorded program includes commercials, the VCR will rewind the tape

automatically and mark the commercials. "CM SEARCH" will flash in the VCR's display.

- Press the button (2) to cancel the markings.

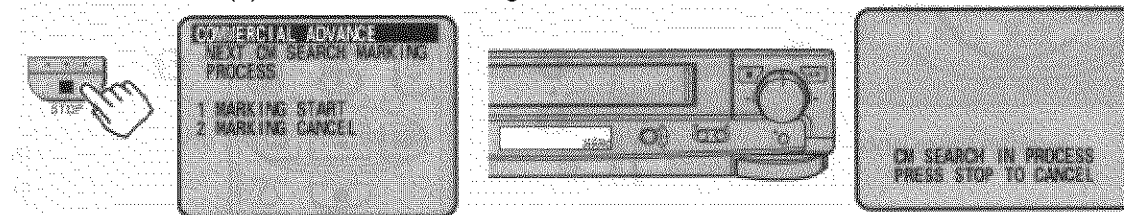

**Note:** Do not press buttons during rewinding the tape to mark commercials. To cancel marking during rewinding, press the STOP button. The screen on the right will appear. Press the STOP button again; markings will be cancelled.

## To watch one program while recording another

1 Once you have set the VCR for recording, press the VCR/TV button.

The VCR indicator disappears. Now, you will be viewing through your TV only.

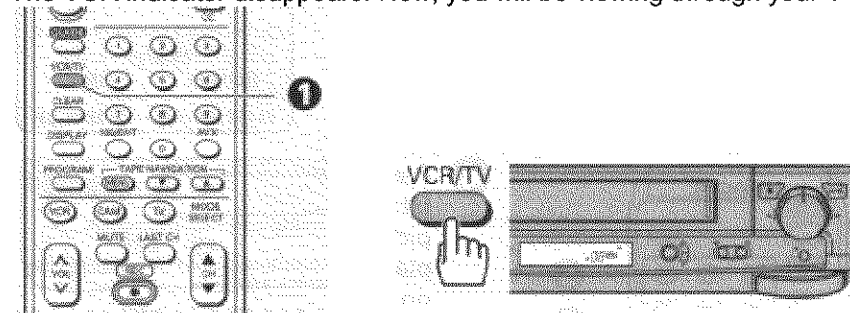

2 Switch channels using your TV controls or the VCR remote, if it's programmed to control your TV (see page 63).

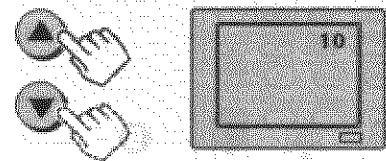

### Notes:

- You can check on the recording by pressing VCR/TV again. This will switch you back to viewing through the VCR, and you'll see the program you are recording.
- If you're hooked up with an audio/video cable: Switch the TV from **AUX** or **VIDEO** mode back to the TV mode, then select the channels you want to watch, as described in Step 2. Switch TV back to **AUX** or **VIDEO** to monitor your recording.
- You cannot view a DSS program while recording another program.

## To change the channel being recorded

1 Press the PAUSE button to stop the recording temporarily.

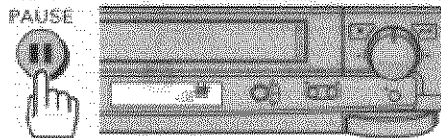
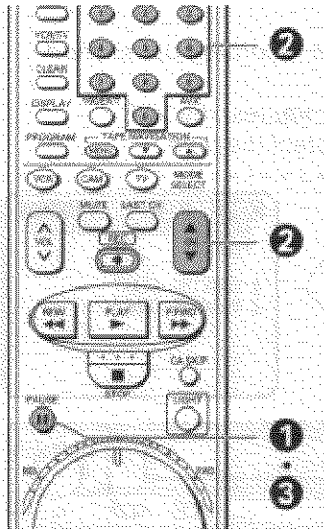

**2 Press the CH (▲/▼) button or number buttons to change the channel to the one you prefer.**

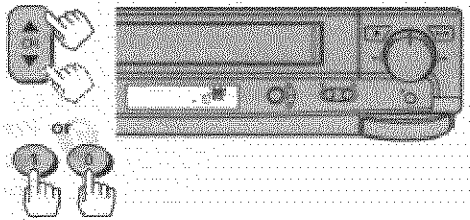

**3 Press the PAUSE button to continue recording.**

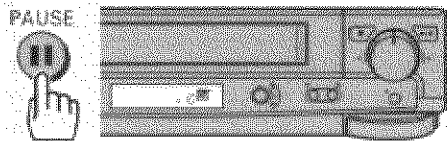

### Automatic Indexing

Your VCR will automatically create an invisible "INDEX" mark every time you press the REC button while recording. During playback, the Index Search feature will let you move through a tape that has several recordings on it by searching for the "INDEX" mark. See Page 39, "Jump to an Index Mark with INDEX".

### To record a Second Audio Program (SAP)

Some stations transmit a Second Audio Program - such as in a second language. If a station broadcasts in SAP, the SA indicator will display on your TV screen.

You can set the VCR to record a second audio program by activating the SAP option.

### How to set the SAP option.

**1 Press the GUIDE button.**

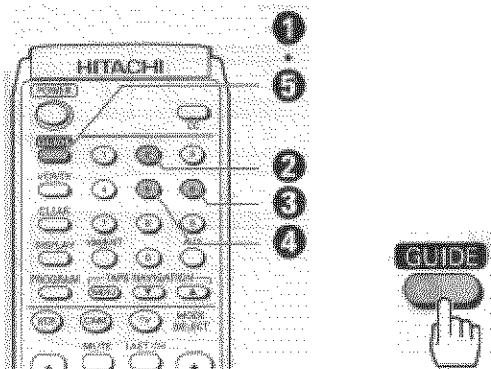

2 Press the (2) button to select the VCR SETUP operation.



3 Press the (6) button to set the SAP option to "ON".

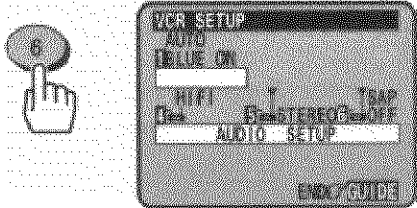

4 Press the (5) button to set the STEREO/MONO option to "STEREO".

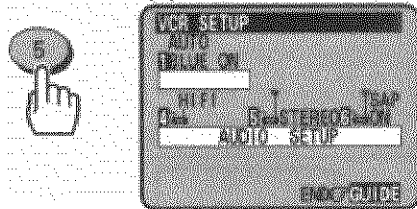

5 Press the GUIDE button to end the setting.

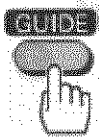

6 Follow the Step 1 through 5 on "Basic Recording Steps" on pages 42 and 43.

### Stereo vs. mono sound

When you select the STEREO option in the initial setup operation, your VCR records in stereo any station that broadcasts stereo sounds. When a TV channel broadcasts in stereo, you'll see a stereo indicator on the TV screen.

Set to MONO if the stereo signal is weak and the sound is too "noisy".

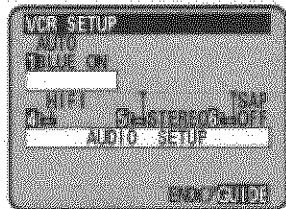

**Note:** When you select MONO, sound is recorded as mono even when a channel broadcasts in stereo.



### Using the Instant Recording Timer (IRT)

The Instant Recording Timer (REC/IRT button on the VCR) will let you make a simplified timer recording without having to use the programming timer. In order to set the IRT properly the clock must be set before starting.



1 Follow the steps 1 through 5 on "Basic recording steps" on pages 42 and 43.

2 Press the REC/IRT button twice to indicate the recording time on the display.

- You may increase the recording time by 30 minutes each time you press the REC/IRT button.
- While you are recording, the remaining recording time is shown on the VCR display.
- At the end of your recording, the display will read "0:00", recording will stop automatically, and the VCR will turn itself off.

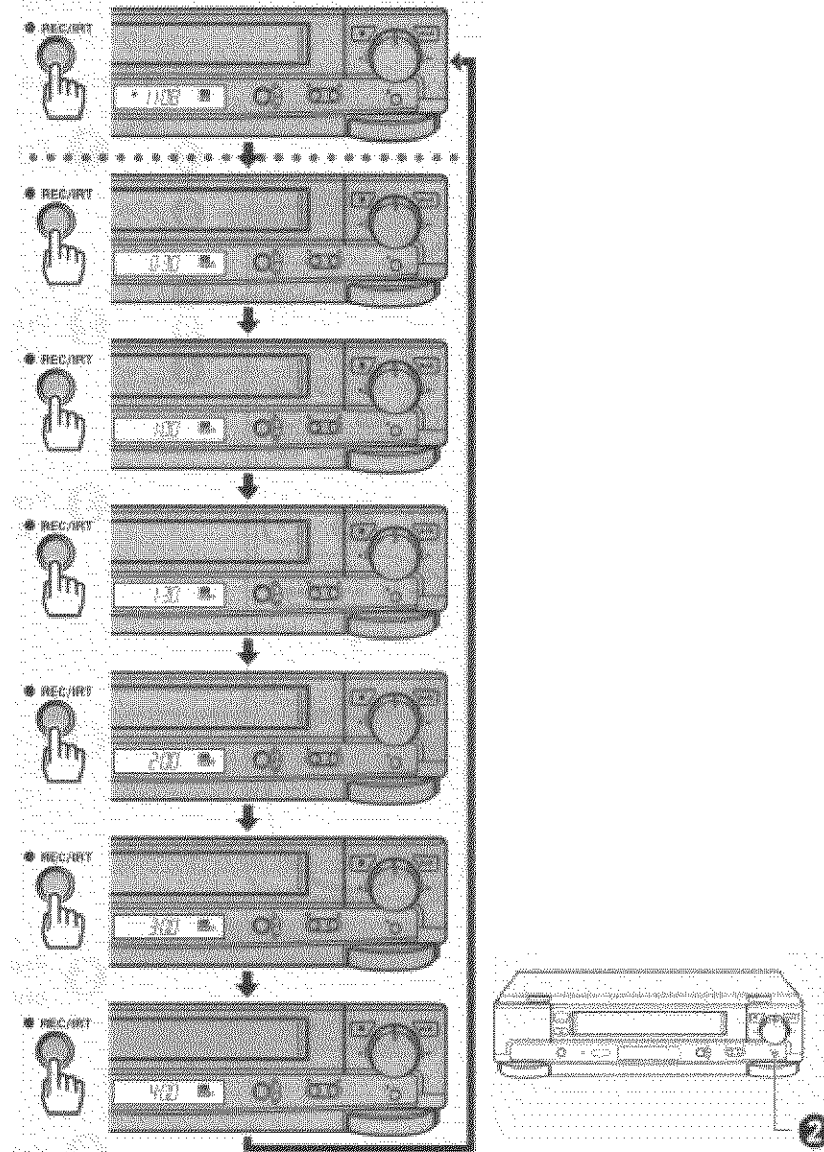

To stop recording while in the IRT mode:

1 Press the POWER button.

2 Press the STOP button within 10 seconds.

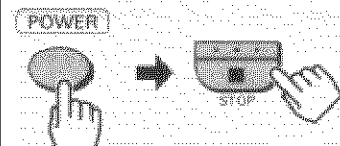

- This can be done either on the VCR or with the remote control.

## Setting the VCR to record later

**Note:** The cassette safety tab must be in place in order to record.

To re-record on a cassette which has its safety tab removed.

Cover the hole with cellophane tape.

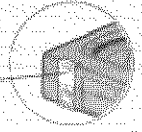

With the delayed recording feature, you can set this VCR so that it automatically turns on and records programs whenever you like - without your being around! You can record a program one time only, or you can automatically record a show every weekday or every week at the same time. You can preset as many as 8 timed recordings at once.

Recording is even easier when you have set up your channels for the VCR Plus+ system. Learn the basics of delayed recording in this section. Then read about the VCR Plus+ system beginning on page 51.

### Before you begin

Assemble the information you need for timed recording:

- Be sure that the clock is set to the correct time
- Date and day of the program
- Starting time
- Ending time
- Channel to be recorded
- Blank or erasable videocassette (safety tab intact)

### Delayed Recording Steps

You set up the delayed recording using the on-screen Easy Guide System.

#### 1 Insert blank or erasable tape.

The power comes on automatically and the tape indicator lights on the display.

- If a cassette without its safety tab is inserted, playback starts automatically and timed record won't operate.

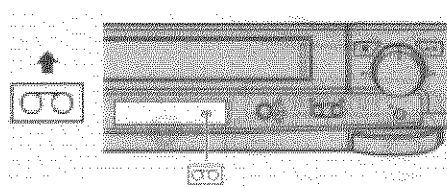
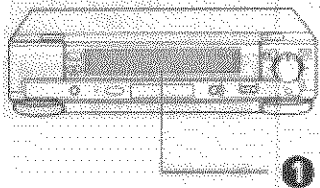

#### 2 Turn on the TV and select the video channel (3 or 4).

Or, if you are hooked up with an audio/video cable, set the TV to AUX or VIDEO.

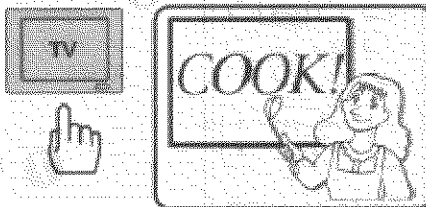
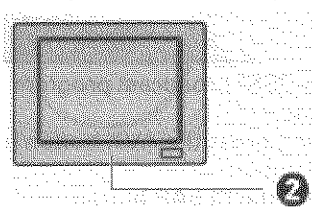

#### 3 Press the PROGRAM button twice for delayed recording.

- Press the PROGRAM button once, the screen for VCR PLUS+ programming of the timer will appear. Press the PROGRAM button twice, this screen will appear.

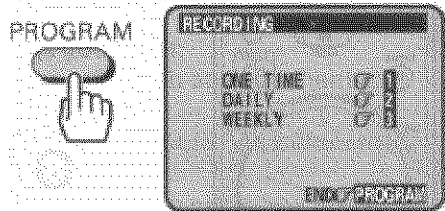
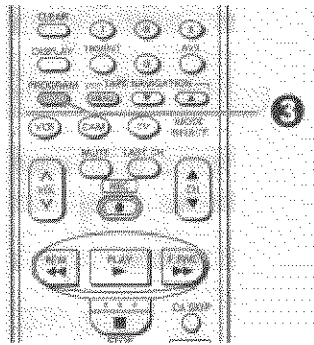

### Types of Delayed Recordings

- ONE TIME      Records one show at a particular date and time.
- DAILY         Records a show at the same time every day of the week, Monday through Friday.
- WEEKLY      Records a show at the same day and time every week.

**EXAMPLE:** Set the VCR to record "one time", a program on **Channel 8** that starts at **6:00 PM** and ends at **6:30 PM** on **7/10/97**, at the **EP** recording speed.

#### 4 Press the (1) button to bring up the screen for One Time Recording

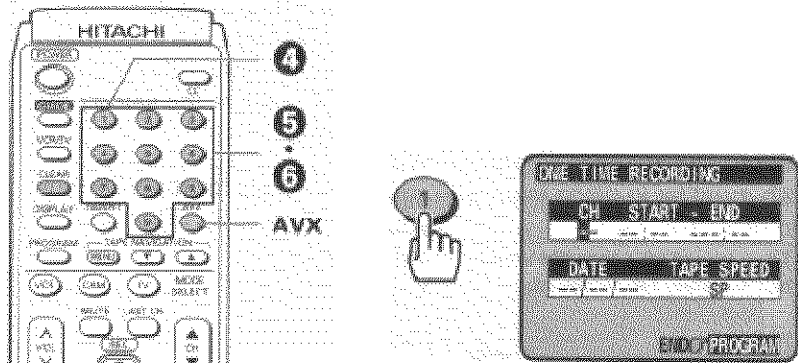

#### 5 Press the (0) and (8) buttons to select channel 8.

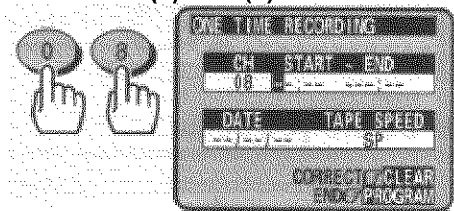

**Note:** Remember to press 0 before single-digit channel numbers, times, and dates.

- If the DSS box has been set up (see page 30), three dashes "---" will appear for the channel display instead of two dashes "--". Press (0), (0) before entering a single digit channel number. For example, press (0), (0) and (8) for channel 8. Press (0) before entering a two-digit channel number. For example, press (0), (1) and (2) for channel 12.
- If the DSS box has been setup and you select a DSS broadcast program for the channel to be recorded, "DSS" will appear.
- If you want to record from an external equipment, press the AVX button to select LINE 1 or LINE 2 instead of the channel number.

AVX

• If you make a mistake when entering digits, press the CLEAR button repeatedly to display "-" for the incorrect digit, then reenter the correct digit.

**6 Enter the start time by pressing (0), (6), (0) and (0) for 6:00.**

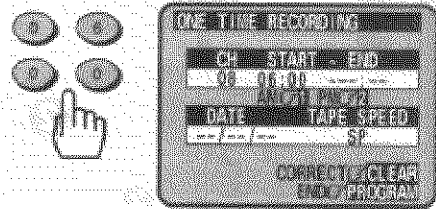

**7 Press the (2) button for PM.**

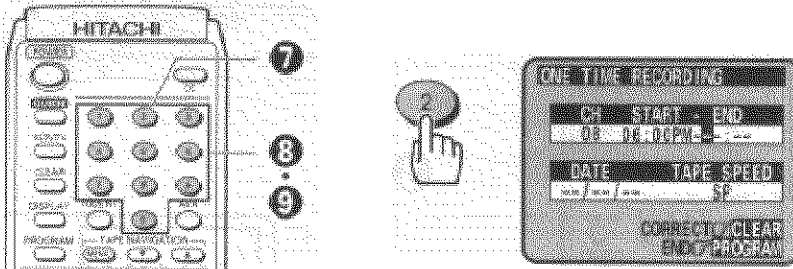

**8 Enter the end time by pressing (0), (6), (3) and (0) for 6:30.**

The VCR automatically selects PM for you.

• The screen shows today's date, so no changes are needed on that line.

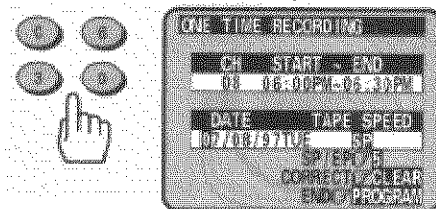

**9 Enter the recording date by pressing (0), (7), (1) and (0) for 7/10/97.**



Click to see remote control illustration.

**10 Press the (5) button to select the recording speed EP.**

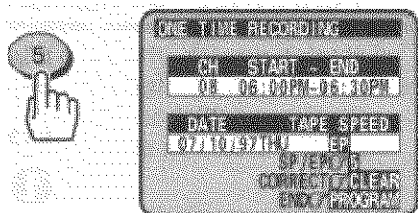

**11 Press the PROGRAM button to set the program in memory.**



**12 Press the POWER button to turn off the VCR.**

The delayed recording indicator will display on the VCR.

This tells you that the VCR will automatically record at the times and dates you have programmed.

- If you are using a cable box, you must **select the channel you want to record on the cable box** (in this case 8); and **turn on the cable box**.

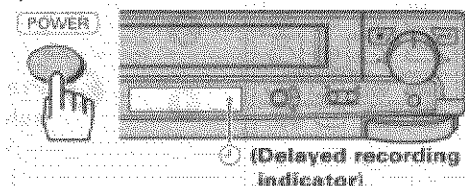

**Note:** You can correct any item entered as you go by pressing the CLEAR button repeatedly until the digit to be corrected changes to white dash "-" on the screen. Then enter the correct number. Illogical times and dates won't be accepted.

**To stop recording while in the timed recording mode:**

**1 Press POWER button.**

**2 Press the STOP button within 10 seconds.**

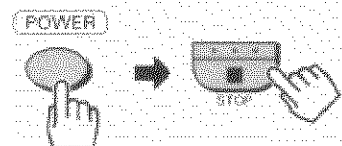

- This can be done either on the VCR or with the remote control.

**When you have set up all the timed recordings you want:**

- Don't forget to load a videocassette (with the safety tab still attached) to record on.
- If using a cable box the VCR can control, turn on the cable box before the time the recording is to begin.
- If using a cable box the VCR cannot control, turn on the cable box and tune it to the channel you want to record before the time the recording is to begin.
- If you use a DSS box which can be controlled by the VCR, turn on the DSS box before the time the delayed recording is to begin.
- If you use a DSS box which cannot be controlled by the VCR, press the AVX button to select LINE 1 in the step 5, not a channel to be recorded, then turn on the DSS box before the time the delayed recording is to begin and tune the DSS box to the channel which you want to record.

**When the DSS box has been set up and <CATV1> or <CATV2> is specified for "1 CHANNEL" on the "CHANNEL PRESET" screen**

If you have selected one of the channels 100-125 when programming the timer, the following screen will appear.

**Example: Programming DSS or CATV channel 120 for delayed recording:**

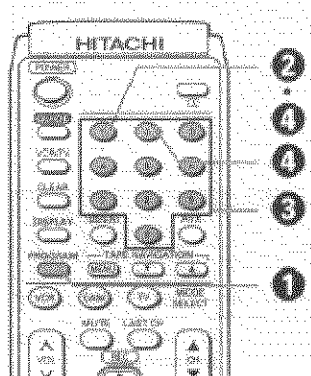

1 Press the PROGRAM button twice.

2 Press the (1) button.

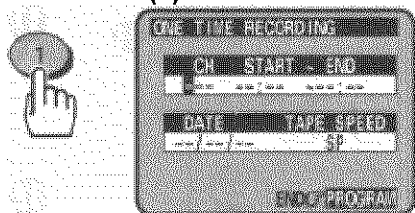

3 Press the (1), (2), (0) button to select channel 120.

• You can select one of DSS or CATV channels 100-125.

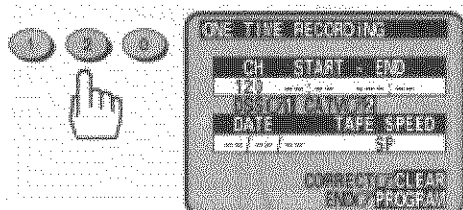

4 Press (1) to record the DSS channel.

DSS channel 120 is selected.

"DSS" will appear under the channel indication.

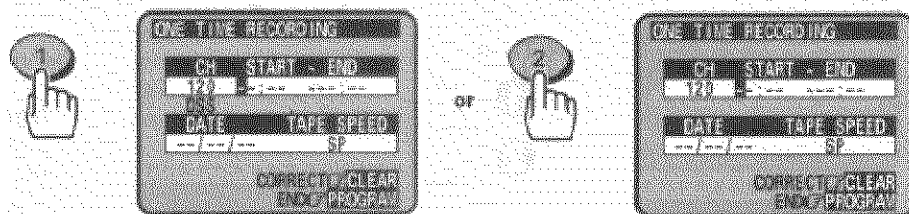

Press (2) to record the CATV channel.

CATV channel 120 is selected.

5 Perform the same procedure described on pages 48 and 49 to enter the recording time, end time, date and tape speed (SP or EP).

## About the VCR Plus+ system

This handy feature makes timed recording a snap. You don't need to enter the specific channel, date, time or duration of a program. All you enter is its PlusCode programming number - a number of up to eight digits. This

special code is easy to find in your favorite TV program guide or daily newspaper. Here's a sample page from TV Guide showing PlusCode numbers next to each program.

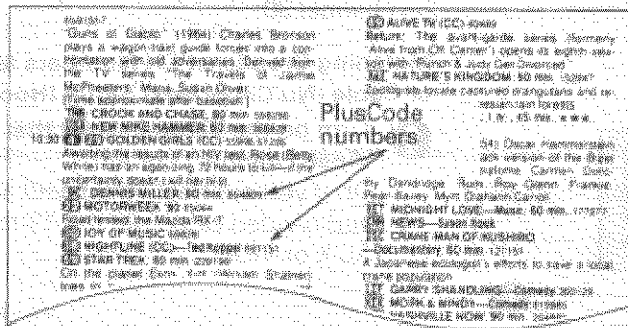

Your local channels may be different from the VCR Plus+ channel codes. To get ready to record with the VCR Plus+ system you need to assign your local broadcast and cable channel numbers to the VCR Plus+ channel codes already stored in your VCR's memory. This is called channel setup and you do it using the on-screen Easy Guide System and the following step-by-step instructions. Then you will be ready to begin VCR Plus+ recording, also using the on-screen Easy Guide System.

VCR Plus+ and PlusCode are trademarks of Gemstar Development corp.

**Note:** You cannot use the VCR Plus+ system for a timed recording of a DSS program. Program the timer manually (see page 47).

## Channel setup

### Before you begin

1 Look for a listing like this one in your local TV program guide or Sunday newspaper TV section. Notice the small numbers to the right of the station name.

These are the VCR Plus+ channel numbers that you will use in the channel setup procedure.

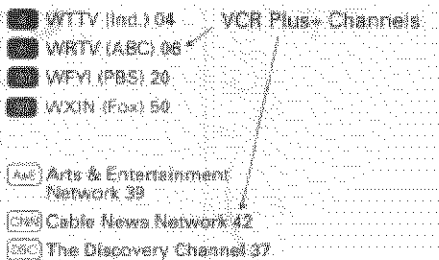

2 Make a list of the VCR Plus+ channel numbers and the channel numbers you are receiving on. If there are any difference, YOUR channel numbers must be assigned to the corresponding VCR Plus+ number. (See Example)

### EXAMPLE

VCR Plus+ Channel Number	Channel Number You Receive
04 (ind.)	04
06 (ABC)	06
20 (PBS)	08
42 (Cable News Network)	38

Note in the example that the channel numbers are the same except for **20** (received on channel 8) and **42**

(received on channel 38). These two channels must be assigned.

This setup should be performed if you are using an Antenna or Cable without a cable box. (Hookups [A], [B], [C] or [D].) If you receive all your channels through a cable box (Hookups [E], [F] or [G]) please refer to page 27 "cable box setup" in "First Time Setup" section.

### VCR Plus+ setup - Channel setup

The following shows the procedure you should perform when you are receiving the Cable News Network (channel 42 with the VCR Plus+ system) on channel 38.

Example

VCR Plus+ Channel Number	Channel Number You Receive
42	38

#### Matching Broadcast CH Numbers to VCR Plus+ Channels for Home Antenna or Cable (No Cable Box) Setup (Hookups [A], [B], [C] or [D].)

**1 Turn on the TV and select the Video channel (3 or 4).**

Or, if you are hooked up with an audio/video cable, set the TV to AUX or VIDEO.

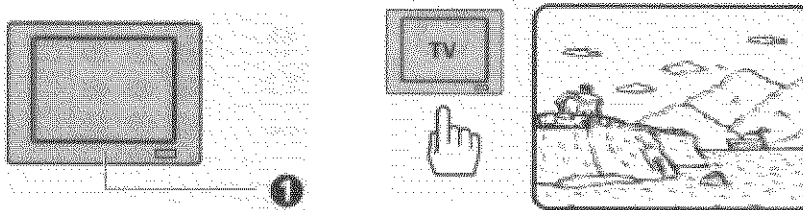

**2 Press the GUIDE button.**

The main on-screen menu will appear on the TV screen.

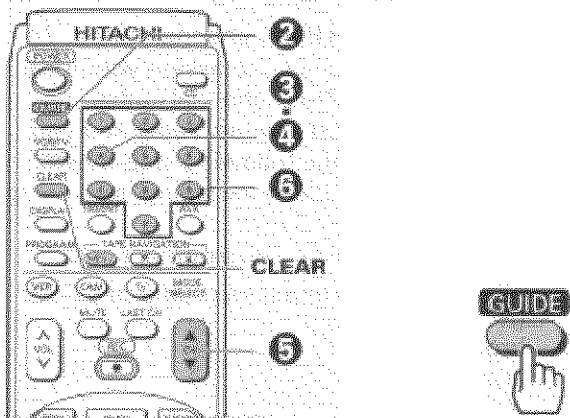

**3 Press the (4) button to select CHANNEL PRESET.**

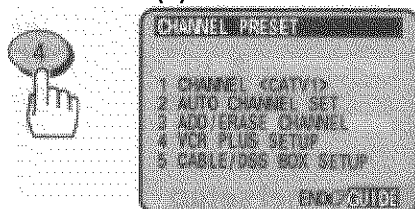



**4 Press the (4) button to select VCR PLUS+ SETUP.**

A small arrow points to a blank "--" in the CHANNEL column.

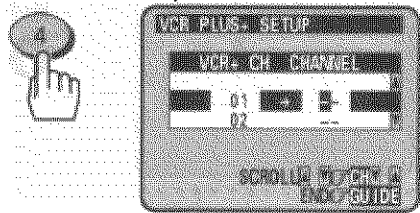

**Note:** If your broadcast channel number is the same as the VCR Plus+ Channel in your TV listing do not enter any number.

**5 Press the CH (▲/▼) button to move up and down through the channel list until you reach VCR Plus+ CH42.**

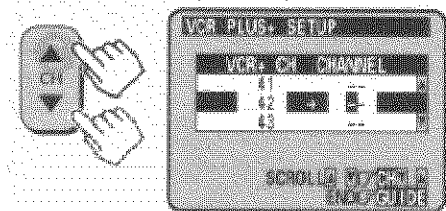

**6 Press the number buttons to assign your broadcast channel number to the corresponding VCR Plus+ channel.**

In this example broadcast channel 38 is assigned to VCR Plus+ channel 42.

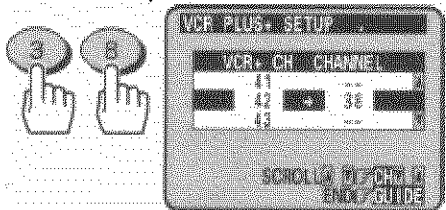

**Note:** If you enter a wrong digit, press the CLEAR button to erase the wrong number and enter the correct one.

**VCR Plus+ setup - Channel setup**

**7 Repeat steps 5 - 6 for all channels that need to be assigned.**

**8 Press the GUIDE button twice to end the setup procedure.**

You are ready to begin delayed recording with the VCR plus+ system.

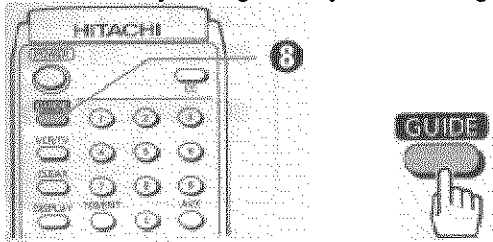

**Using the VCR Plus+ system to record a program**

**1 Insert a blank or erasable tape.**

The power comes on automatically and the tape indicator lights on the display.

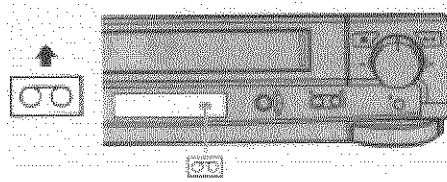
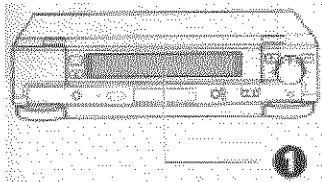

• When a cassette without its safety tab is inserted, playback starts automatically and VCR Plus+ recording won't operate.

**2 Press the PROGRAM button to select VCR PLUS+ RECORDING.**

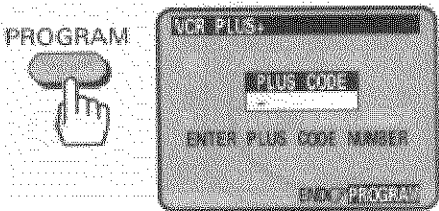
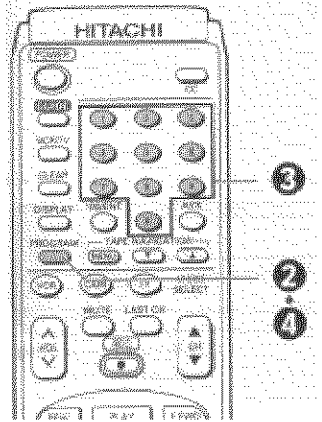

**3 Press the number buttons to enter the PlusCode number of the program you want to record.**

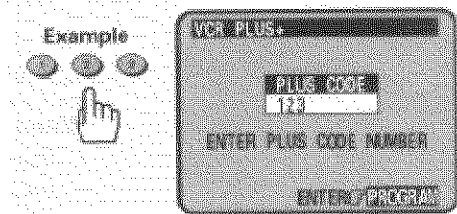

**4 Press the PROGRAM button to store the PlusCode number in the VCR's memory.**

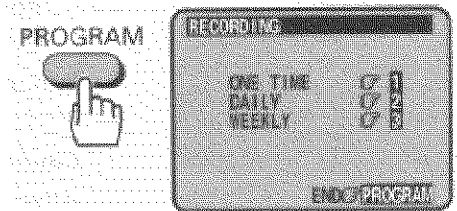

**Types of Delayed Recordings**

- ONE TIME      Records one show at a particular date and time.
- DAILY         Records a show at the same time every day of the week, Monday through Friday.
- WEEKLY      Records a show at the same day and time every week.

**Note:** If you accidentally enter a nonexistent PlusCode number, the VCR gives you an error message that disappears from the screen in about 10 seconds.

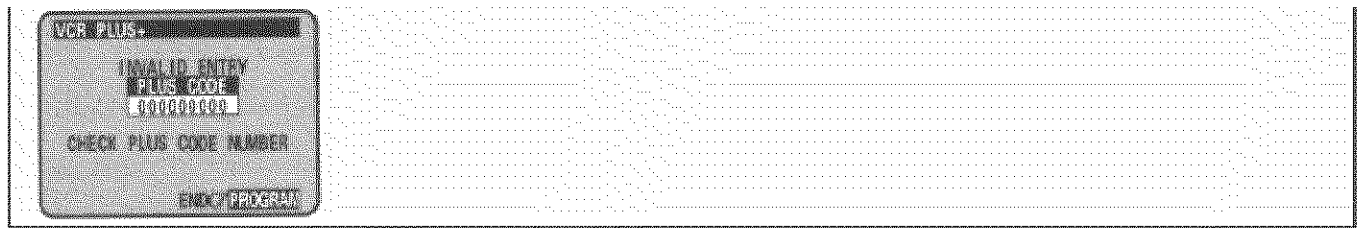

**5 Press the number buttons (1), (2) or (3) to select ONE TIME, DAILY or WEEKLY RECORDING**

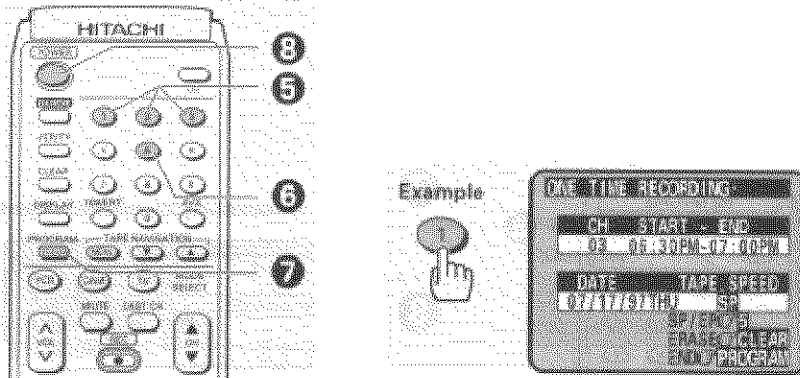

**Note:** Programming does not take effect unless you select one of these options.

**6 Press the (5) button to choose recording speed SP (standard play) or EP (extended play).**  
 The screen will display all the details of the program you chose. Check the CH number to make sure it is the right one. If not, you need to check your VCR Plus+ channel setup again.

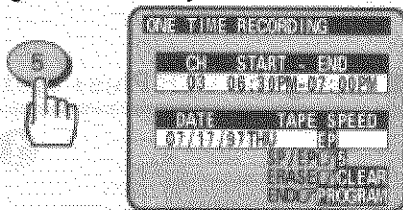

**7 Review the screen to be sure everything is set as you want, then press the PROGRAM button to complete your programming or continue with additional programs.**



**8 Press the POWER button to turn off the VCR.**  
 The delayed recording indicator will display on the VCR.  
 This tells you that the VCR will automatically record at the times and dates you have programmed.

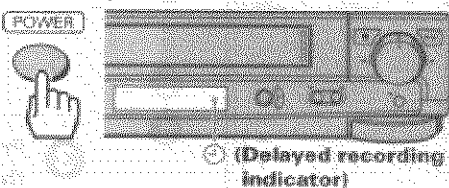

When you have set up all the timed recordings you want:

- Don't forget to load a videocassette (With the safety tab still attached) to record on.
- If using a cable box the VCR can control, turn on the cable box before the time the recording is to begin. Please refer to "Cable Box Setup", on Page 27 in the "First Time Setup" section.

**Important:** Your timed recording settings take effect when you turn off the power on the VCR.

### Caution of VCR Plus+ Recording

After entering a PlusCode number, check the information displayed with the "PROGRAM REVIEW". If there is (are) any unnecessary program(s), please cancel or correct it (them). Please refer to Page 55, "Reviewing what you have programmed".

## Reviewing what you have programmed

You can look back over any of the recordings you have preset and if you need to, clear out any of the programs. Normal programs will clear automatically once recording is complete, but daily and weekly settings must be cleared out manually.

### 1 Press the GUIDE button.

The main on-screen menu will appear on the TV screen.

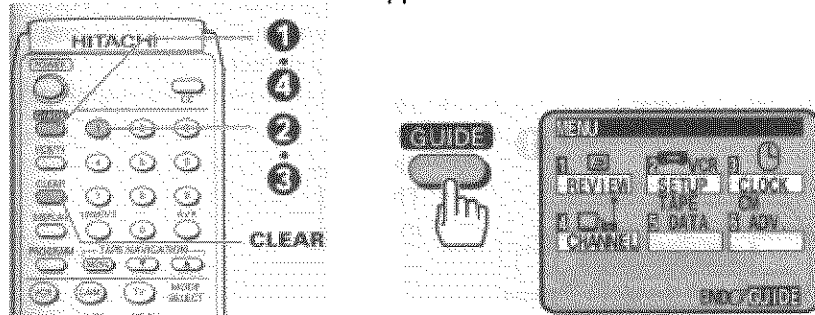

### 2 Press the (1) button for the PROGRAM REVIEW option.

This brings up the screen setting for the first program.

If you want to clear this program, press the CLEAR button to remove this program.

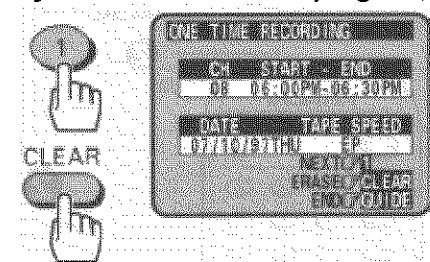

### 3 Keep pressing the (1) button to cycle through all the programs you have preset.

• The screen will display the next program, if there are more, or it will switch back to the main menu.

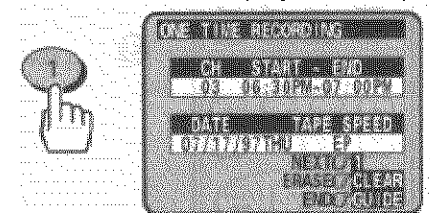

### 4 Press the GUIDE button to end.



## Tape navigation and directory screen

Whenever this VCR records a program, specific information is automatically stored in the VCR memory. This information can be displayed on the TV screen in a directory, and used to locate a recorded program you want to watch, or the beginning of a non-recorded section of the tape.

- Tape Navigation will not work unless the tape was recorded by this VCR.
- The Tape Navigation data will be remembered even during a power loss. The data will not be lost unless there is a memory defect.
- This VCR can store about 80 programs (including non-recorded segments) in memory.

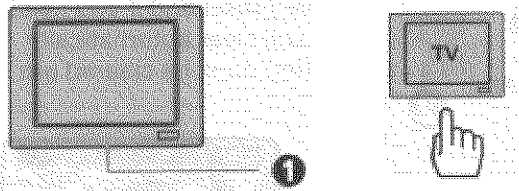

### 2 Insert a tape recorded by this VCR.

The power comes on automatically, the tape indicator lights on the display, and the "MENU" button on the VCR flashes. (It flashes to show that tape navigation is operational.)

Then the MENU button lights.

- It may take approx. 10 seconds until the MENU button lights.

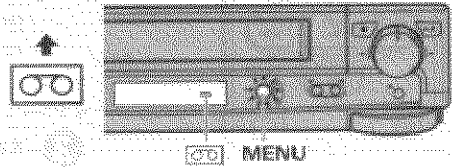

### 3 Press the MENU button on the VCR or the remote control. The directory screen will appear.

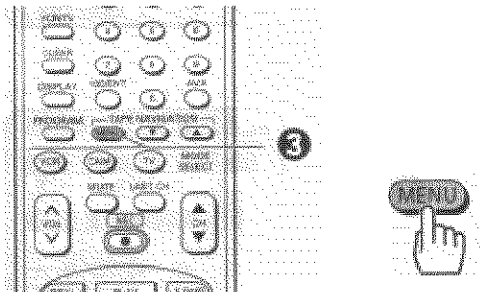

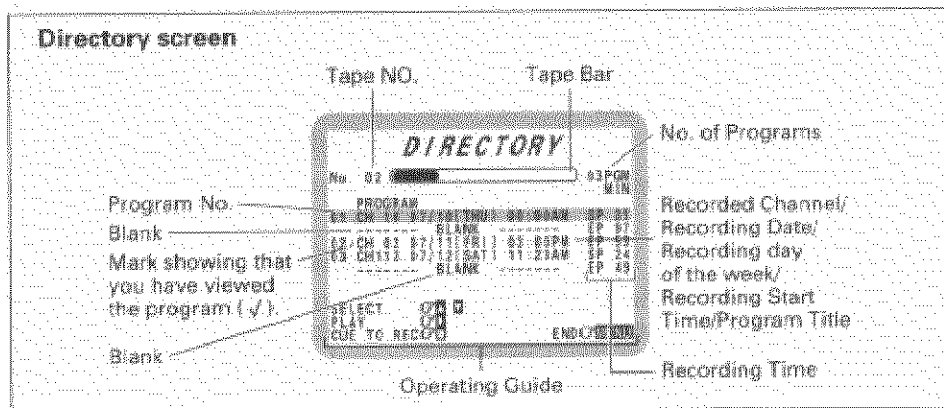

### Understanding the Directory

- Tape Number** Identifies the tape in the VCR.
- Number of Programs** Shows the number of programs recorded on the tape.
- Tape Bar** Shows the length of a recorded program and its location on the tape.
- Recording Time** Shows the actual recording time. If the tape speed (SP/EP) was changed during recording, the recording time at the EP speed will be shown.
- Date** Displayed if the recorded program did not have a program title signal.
  - If the clock is not set, "--/--", "--/--" will be displayed.
- Start Time**
  - If you use a cable box to receive all channels, the cable box output channel will always be displayed.
- Channel**
  - If a DSS program has been recorded using the timer, LINE 1 is always displayed no matter which channel is recorded.
  - When a broadcast program with a program title signal is recorded, program title appears. If the title is too long, all the title characters may not be displayed.
- Day of the Week**
- Program Title**
- Operating Guide** Shows the button names and the operations that can be done when the directory is being displayed.
- Blank** Shows the blank (non-recorded) sections and the maximum amount of time for which a new recording can be made at the EP speed.
- Program Number** Shows the number of the recorded program registered by the VCR. This number will be highlighted when selected.
- Viewed Mark** Shows that you have already watched more than half of a recorded program from its start.

#### NOTES:

- There may be a 3 minute difference between the recorded time displayed and the actual recorded time.
- If the tape navigation does not appear
  - A) Play the tape for about 2 minutes from its start and then press the MENU button.
  - B) Fast forward (Rewind) the tape slightly until you reach the beginning of a recorded segment, then press the MENU button.

### Storing tape data in memory

If you are using a T-120 tape for recording, no special procedure is required.

If you are using a T-140, T-160, T-180 or T-210 tape, you must select the type of tape you are using in order to properly store the data into memory.

#### 1 Insert a blank cassette into the VCR.

The MENU button will flash for about 30 seconds, and "120" flashes in the VCR's display for about 10 seconds.

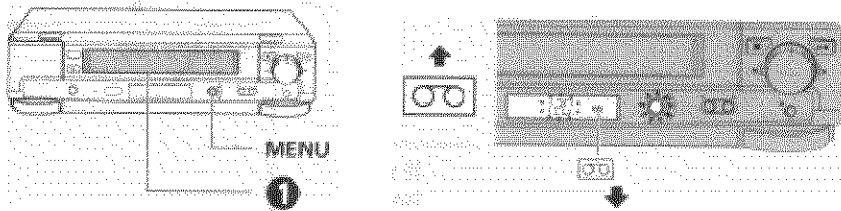

**2 Press the CLEAR button to choose the type of tape you are using.**

- 120: T-120 or shorter tape
- 160: T-140 or T-160 tape
- 180: T-180 tape
- 210: T-210 tape

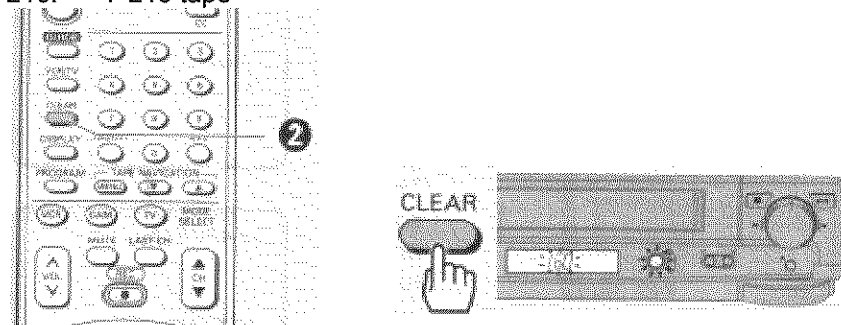

- The display is displayed for a short time, so you must press the button quickly.
- If you are not using a T-140, T-160, T-180 or T-210 tape, choose "210". When the display disappears, proceed with normal or time-delayed recording.

**NOTES:**

- Once you select the length of a tape, it is not necessary to select it again for future recordings on the same tape.
- Record programs in sequence from the beginning of the tape.
- If you record for less than 5 minutes at the SP speed (15 minutes at the EP speed), tape data will not be stored in memory.
- If you select an incorrect tape length, the correct data will not be stored.

**How to locate the beginning of a program or a non-recorded (blank) section**

**1 Insert a tape recorded by this VCR.**

The power comes on automatically, the tape indicator lights on the display, and the "MENU" button on the VCR flashes.

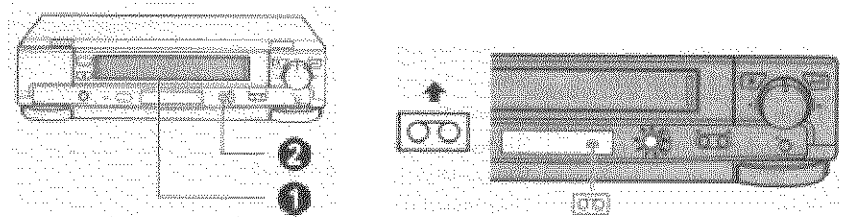

**2 Press MENU button on the VCR or the remote control. The directory screen will appear.**

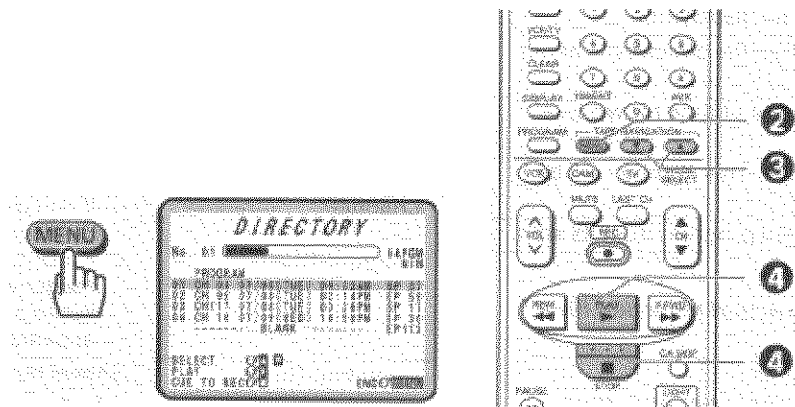

**3 Press the select  or  buttons to choose the program you want to watch. The number selected will be highlighted.**

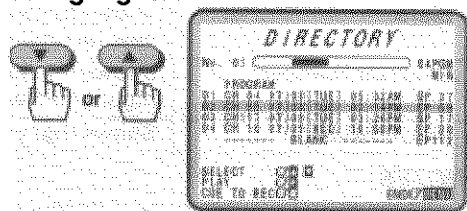

**4 If you want the selected program to play automatically, press the PLAY button.** The search screen will appear while searching for the selected program. When the program is found, playback will begin automatically.

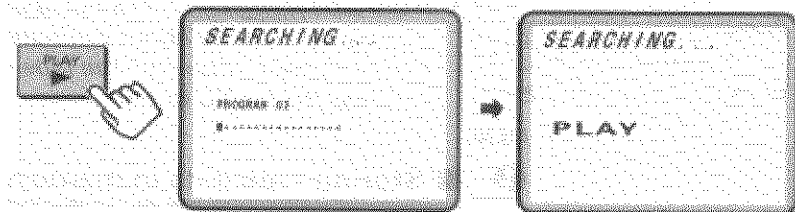

**If you want the VCR to stop at the beginning of the selected program: Press the STOP button.** This screen will appear while searching for the selected program. When the program is found, the VCR will stop automatically.

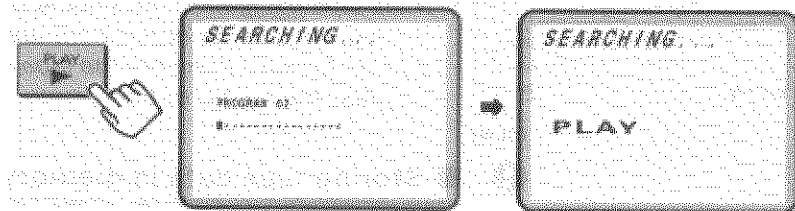

• If you selected a "blank" section in step 3 press the STOP button. SEARCHING BLANK will appear on the screen, and the tape will stop automatically at the beginning of the blank section.

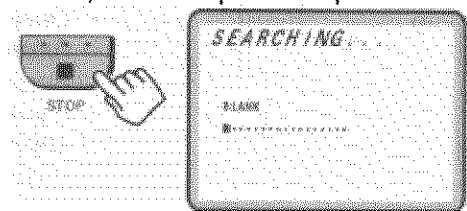

### Tape data menu

The tape data menu will allow you to:



- Turn the tape data feature on and off
- Turn the program title feature on and off
- Display tape navigation data
- Delete tape navigation data

**Note:** If a cassette is in the VCR, eject it before you select the tape data menu.

Press the **GUIDE** button. Then press the **(5)** button.

The tape data menu will appear.

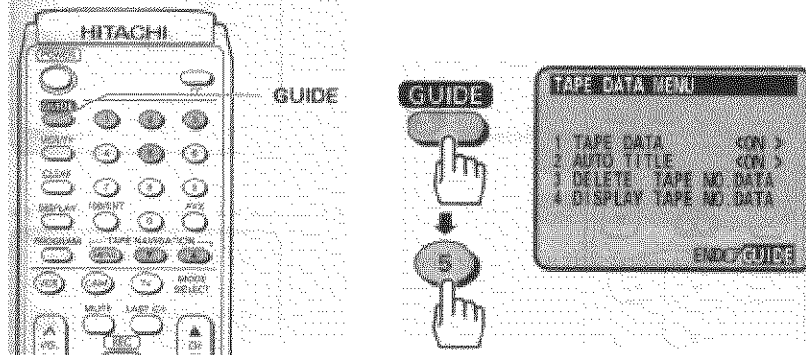

### 1 TAPE DATA <ON>/<OFF>

Press the **(1)** button to switch the TAPE DATA ON and OFF.

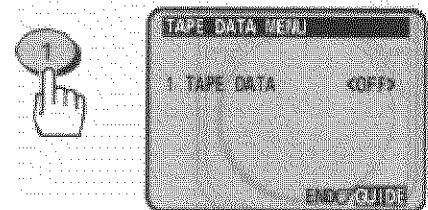

**Note:** With tape navigation OFF, you cannot use option 2 (AUTO TITLE ON/OFF); option 3 (DELETE TAPE NO. DATA); or option 4 (DISPLAY TAPE NO. DATA.)

### 2 AUTO TITLE <ON>/<OFF>

**To turn off program title:**

If you do not want to store program titles in memory.

Press the **(2)** button to turn off the program title. Press the **(2)** button again to turn PROGRAM TITLE ON.

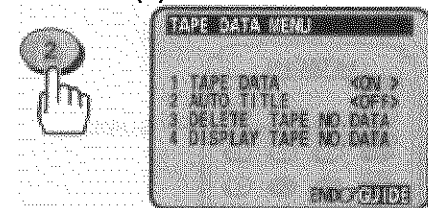

**Note:** When program title is turned OFF, the recording date, start time and channel will be stored instead of the program title.

### 3 DELETE TAPE NO. DATA

**To delete tape data:**

Press the **(3)** button.

The screen will display tape numbers and dates of the recordings made on the tape.

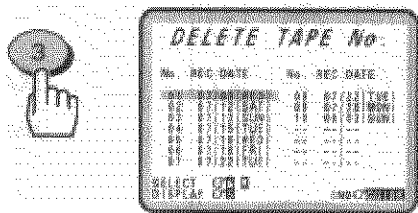

**Note:** You cannot erase the data of the tape loaded in the VCR. Eject the tape before performing the following.

- Press the select or button to specify the TAPE NO. you want to delete.



Press the select button to move toward the lower numbers;  
 Press the select button to move toward the higher numbers.

**EXAMPLE:**

Delete tape number 4.

- 1 Press the select or button to move up or down through the list until number 4 is selected.

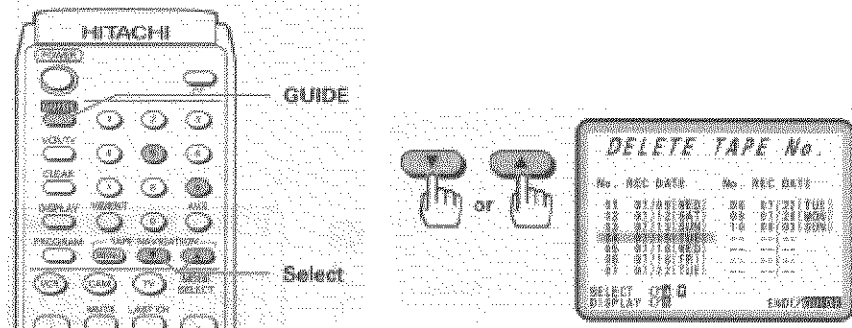

- 2 Press the (5) button to display the detailed data.

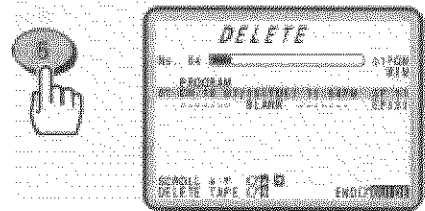

- 3 Press the (9).

The tape number 4 data will be cleared.

- Repeat steps 1 through 3 to delete other tape number data.
- Press the GUIDE button for normal viewing.

**4 DISPLAY TAPE NO. DATA**

To display tape number data:

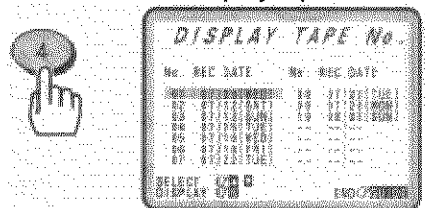

- 1 Press the (4).

The screen will display tape numbers, and date of the recordings on the tape.





2 Press the select  or  button to specify the TAPE NO. you want to display.



Press the select  to move toward the lower numbers.  
 Press the select  to move toward the higher numbers.

**EXAMPLE:**

**Display tape number 2.**

Press the select  or  button to move up or down through the list until number 2 is selected.

**3 Press the (5) button.**

Details of tape number 2 will appear on the screen.

- If you want to review other tape data, press the (5) button to restore the screen in step 1. Perform steps 2 and 3.
- Press the GUIDE button for normal viewing.

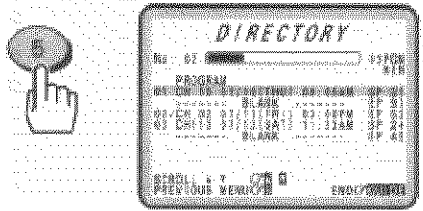

**Precautions**

When tapes recorded without the tape navigation feature are inserted into the VCR, the "120" display (selecting tape length) will appear in the VCR's display automatically. This includes:

- 1 Blank tape
- 2 Tape recorded by another VCR
- 3 Tape recorded with TAPE DATE <OFF>
- 4 Tape whose tape data has been deleted.

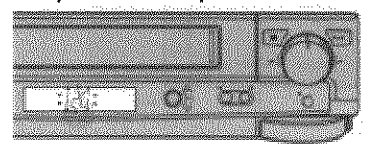

If the MENU button is pressed, 1 - 4 tapes will produce the following screens:

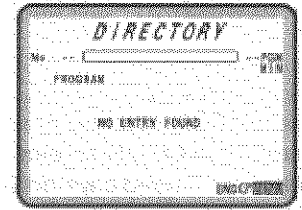

When the tape data memory is full, the following screens will appear when a recording is made or when the timer is programmed:

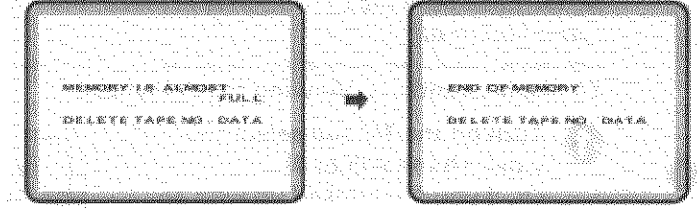

Follow the instructions on page 59 to delete data and provide more space in the tape data memory.

**Dubbing:**

Tape Navigation does not operate with tapes on which only audio is recorded or dubbed from a CDV (compact disc video).

**Contents of data stored in memory when pause is engaged during recording:**

The program number does not change even if pause is engaged during recording. If the channel is changed after pause is instructed, the program number will change.



You can display captions on the TV screen when receiving a program with a closed caption signal via the TV or playing back a tape with a closed caption signal.

- The captions will disappear during forward/reverse search and slow motion play.
- The captions may not be displayed correctly when a tape with scratches or a poorly recorded tape is played back.

**To display captions: Viewing a TV program**

**1 Turn on the TV and select the video channel (3 or 4).**

OR, if you are hooked up with an audio/video cable, set the TV to AUX or VIDEO.

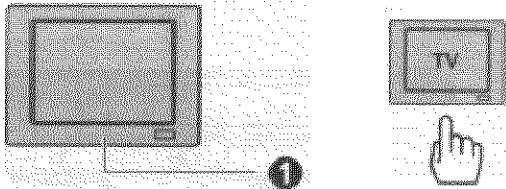

**2 Press the CH ( ) or number buttons to select the channel you want to watch.**

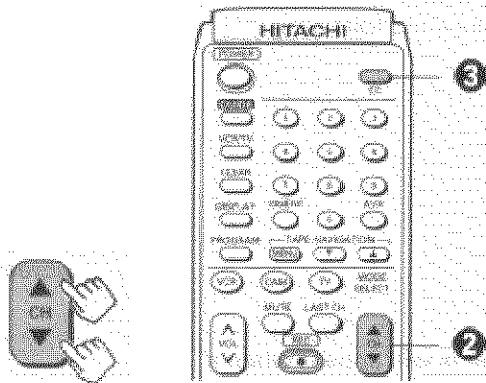

**3 Press the CC button on the remote control. The CC ON screen will appear and closed caption will be displayed in a few seconds.**

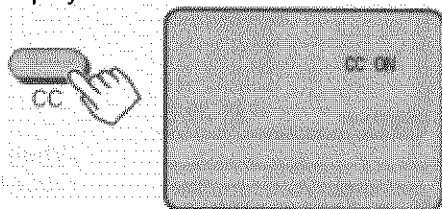

**Note:** Each time the CC button is pressed, the closed caption feature will be turned on or off.

**To display captions: Viewing tape playback**

**1 Turn on the TV and select the video channel (3 or 4).**

Or, if you are hooked up with an audio/video cable, set the TV to AUX or VIDEO.

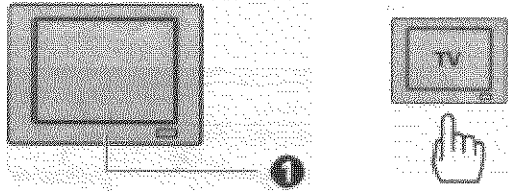

**2 Insert a tape with a closed caption signal into the VCR.**

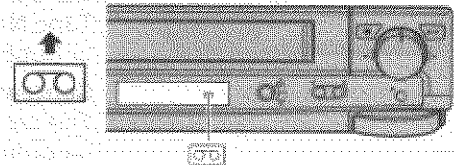

**3 Press the PLAY button on the remote control.**

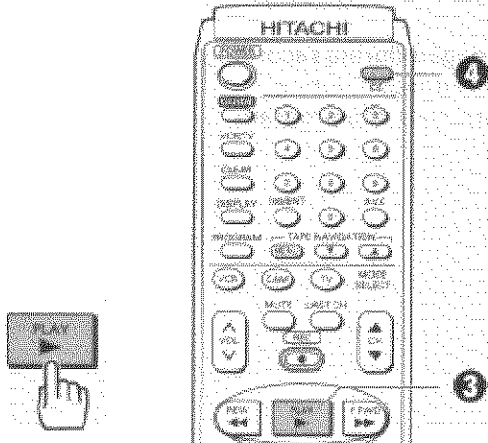

**4 Press the CC button on the remote control.**



The VCR remote control can be programmed to control many TV brands that are remote controlled.

**1 Turn on the TV.**

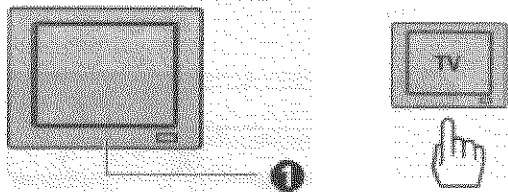

**2 Point VCR remote control toward TV.**

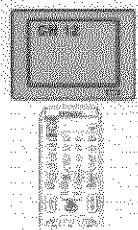

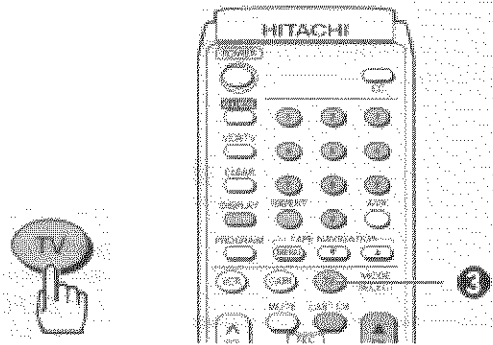

3 Press and hold the "TV" button.



4 Press the remote button corresponding to your TV brand as shown in the set-up chart. The TV channel will change to confirm that the remote control has been set.



TV Brand	Press "TV" and this remote button	TV Brand	Press "TV" and this remote button
Hitachi	1	Panasonic 2	9
Zenith	2	RCA	0
Sony	3	Panasonic 1	CH 
Magnavox	4	Mitsubishi	CH 
Sanyo	5	JVC	100/ENT
Gold star 1	6	Sharp 1	LAST CH
Toshiba	7	Sharp 2	DISPLAY
Gold star 2	8		

**Note:** If your TV brand is not listed on the Set-Up Chart, try all the buttons listed in the chart until the TV changes channels. If the TV channel does not change, you won't be able to program the remote for your TV.

### Using the VCR remote to control your TV

1 Press the "TV" button on remote control.

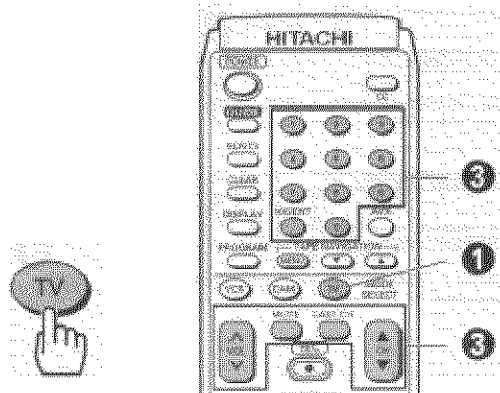

**2 Point VCR remote control toward TV.**

**3 Press buttons corresponding to the functions available on your TV remote control.**



## Hookup

When your VCR is connected to a stereo system, you can:

- Make high quality "audio only" recordings for up to 6 hours (on a T-120 video cassette tape).
- Receive quality stereo sound from your VCR through your stereo system.
- Use the VCR as an extra audio tape deck for dubbing.

Stereo System hookup Illustration

## To record from stereo

BEFORE YOU BEGIN...

- Make sure the VCR is connected to your stereo system, as shown above.
- Make sure that **"STEREO"** audio is selected from the VCR Set-Up Menu, as shown on **Page 45**, of **"RECORDING OPERATION"** Section, **"Stereo vs. mono sound"**.
- Select VCR recording speed (**SP** or **EP**) as shown on **page 43**, of **"RECORDING OPERATIONS"** Section, **"Basic Recording Steps"**.

**1 Press the AVX button on remote control, so that L1 (line) appears on the display.**

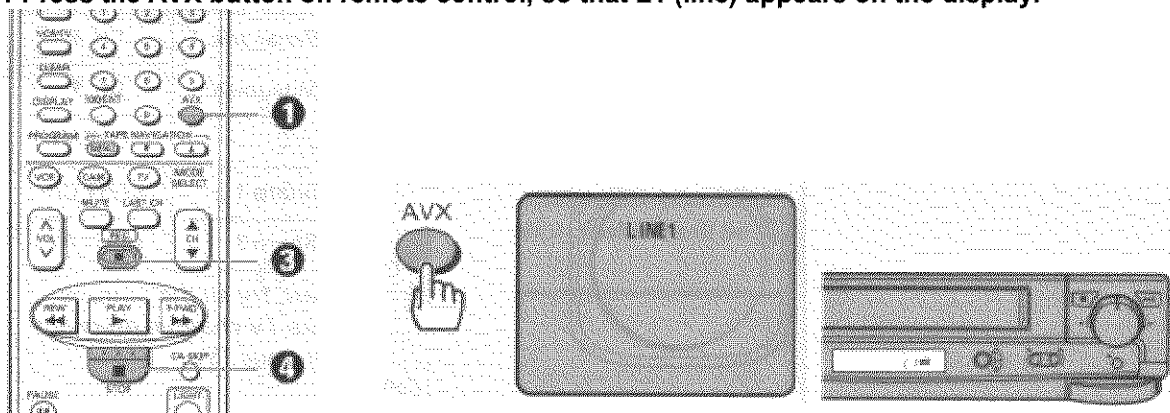

**2 Turn on stereo, and start the selection you wish to record.**

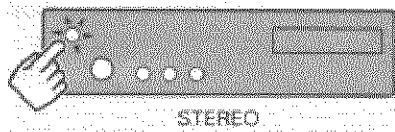

**3 Press the REC/IRT button on VCR or REC button on the remote control to start recording.**

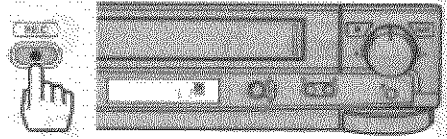

**4 Press the STOP button or remote control to stop recording.**

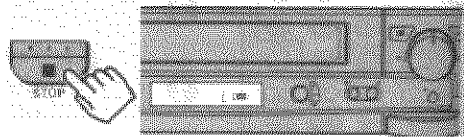

## Hookup

You may use your VCR to copy tapes from any camcorder onto standard VHS cassette tapes.

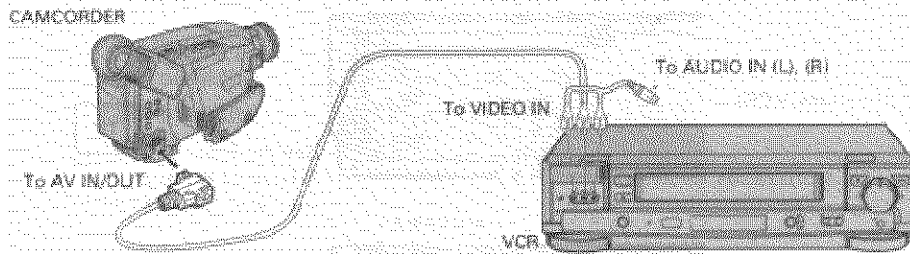

**NOTE:** If your camcorder is not stereo (has only one audio plug), connect it to the AUDIO IN-L input on the front of the VCR.

\* It is not necessary to connect the S-VIDEO jack.

## To copy from a camcorder

### **BEFORE YOU BEGIN...**

Connect the camcorder's AV output cable to the audio/video jacks on the front of your VCR.

**1 Press the AVX button on remote control, to display L2 (line) on the TV display.**



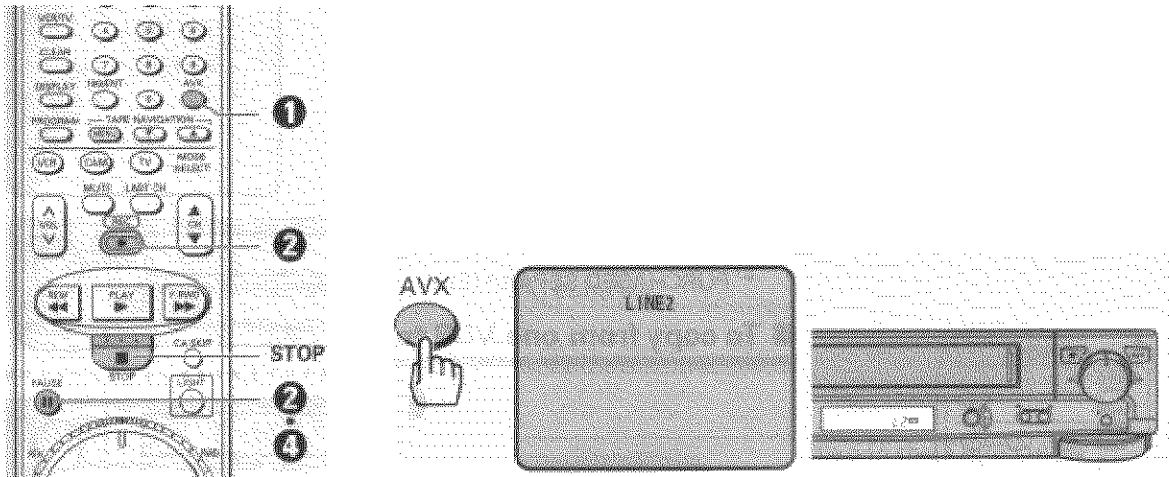

**2 Press the REC, then PAUSE buttons on the VCR remote control. The VCR will go into Record/Pause.**

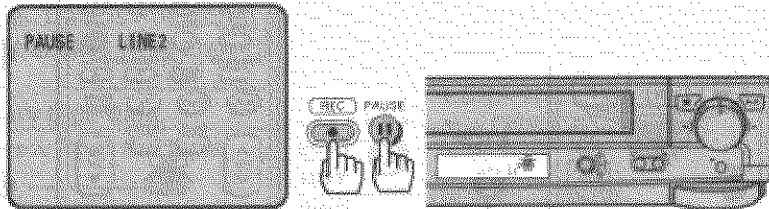

**3 Press the PLAY button on the camcorder. You will see the camcorder tape being played on the TV.**

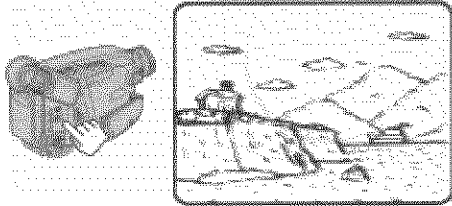

**4 When you see the part of the Camcorder tape you wish to copy, press the VCR PAUSE button again to release pause and start copying the camcorder tape.**

• Press the stop button to finish recording.

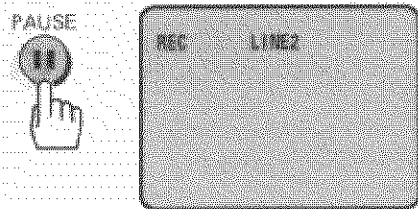

## Hookup

If you have two VCRs, you may use one VCR to record a tape that is being played back in the other VCR.

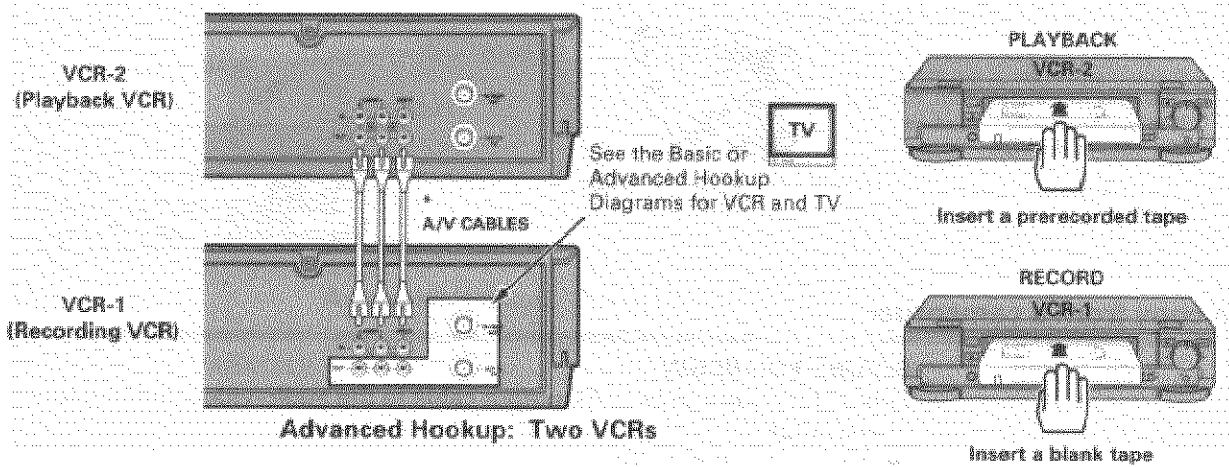

## To copy from one VCR to another VCR

1 Press the AVX button on the remote control of VCR-1 so that L1 (line) appears in the display.

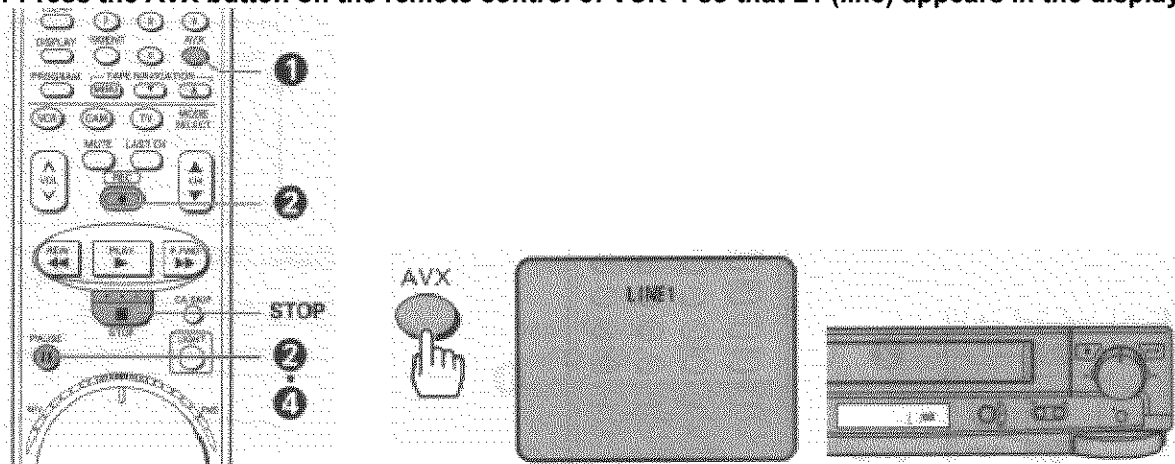

2 Press the REC, then PAUSE buttons on VCR-1. The VCR will go into Record/Pause.

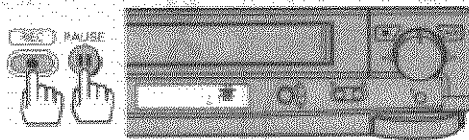

3 Press the PLAY button on VCR-2. You will see the taped program being played on the TV.

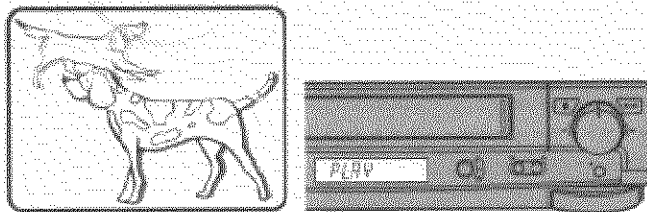

4 When you see the part of the program you wish to record, press the PAUSE button on VCR-1 again to release pause and start recording.

• Press the STOP button to finish recording.

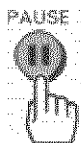

## Problem guide

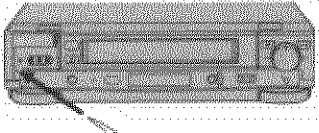
- No power
- Make sure the VCR is plugged into an AC outlet.
- Remote control doesn't work
- Make sure the batteries are fresh, and properly installed.
- Won't record
- Safety tab has been removed from cassette (VCR will automatically eject the tape).
- Won't make timer recordings
- The VCR power must be turned off to activate timer recording.
  - Clock is not set correctly.
  - Programs entered incorrectly.
  - Programs exceed the length of the cassette. Use the EP recording speed for maximum programming.
  - Safety tab has been removed from cassette.
- Snowy picture in playback
- Snow or picture noise is normal during search, still, and slow Playback.
  - Head cleaning may be required.
  - Tape is worn or of inferior quality - adjust tracking controls.
- Snowy picture in normal TV viewing
- Check antenna or cable connections.
- Clock shows --:--
- Power has been interrupted - reset the clock.
  - Reset the clock.
- Erratic VCR display
- Push the reset switch (behind the cover on the VCR front) with a sharp pointed instrument (pen, toothpick, etc.)
- 
- Cannot store tape data in memory
- Check that "1 TAPE DATA <ON>" is specified in the TAPE DATA MENU. If <OFF> is specified, switch it to <ON>.
  - Check the time at which the recording was made. Data is not stored in memory when the recording time is less than 5 minutes (less than 15 minutes in the EP mode).
  - The tape data memory is full. Delete unnecessary tape data.
- Cannot locate the beginning of a program
- You cannot search for a program you want to view from the tape recorded by another VCR.
  - Rewind the tape to its start, then press MENU.
- A DSS broadcast programmed for delayed recording, but not recorded.
- <CATV 1> or <CATV 2> was specified for "1 CHANNEL" on the CHANNEL PRESET screen. Select DSS for the DSS/CATV setting during programming.
  - Turn on the DSS box before the delayed recording starts.
-

## Maintenance

Regular periodic maintenance is required to maintain optimum VCR performance. Such maintenance and adjustments should not be attempted by the user. Please consult your service dealer for further information.

### Auto Head Cleaning System

This system cleans the video heads automatically when a cassette is inserted and ejected or the VCR is turned on or off while a cassette is in the VCR, to prevent dirt from accumulating on the heads.

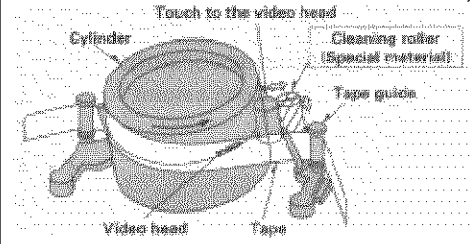

**Note:** Mechanical sound is heard during head cleaning.

**NOTE:** Dirt accumulation on the video heads will cause the playback picture to become noisy. **Heavy accumulations due to abnormal usage, or the use of poor quality tapes may be beyond the capabilities of the Auto Head Cleaning System, and may require the video heads to be professionally cleaned by a qualified service dealer.**

## Technical specifications

Format:	VHS
Video Signal System:	NTSC color EIA standard
Record/Playback System:	Video: 4 head Audio: VHS Hi-Fi stereo record/playback system
Tape Speed:	33.35 mm/sec (SP), 16.67 mm/sec (LP) (playback only), 11.12 mm/sec (EP)
RF Input:	UHF/VHS 75 ohm
Tuner:	USA: 181 channel tuning ability* (125 cable channels) Canada: 178 channel tuning ability* (122 cable channels)
Type:	Auto programming frequency synthesis
Power Input:	AC 120V 60 Hz
Power Consumption:	24W nominal
Cabinet Size:	17-1/8" (W) x 3-7/8" (H) x 11-1/8" (D) 43.5 cm (W) x 9.9 cm (H) x 28.2 cm (D)
Weight:	8.8 lbs. (4.0 kg)
Storage Temperature:	-4°F to 131°F
Operating Temperature:	41°F to 104°F
Accessories:	1 coaxial cable (Part No. EW10251) 1 remote control unit (Part No. HL10701), 2 AA batteries

\*Check your cable company's compatibility requirements.

For information about how to obtain these and other HITACHI accessories, please call HiTRON, Inc. TOLL FREE at 1-800-995-4500 (in the continental United States). For ALASKA and HAWAII, please contact the nearest Hitachi Regional Office.

Design and specifications subject to change without notice.

**Hitachi Service Hotline**

Authorized Hitachi service facilities are available throughout the US and Canada. For the location nearest to you, call the Hitachi Service Hotline at one of these numbers:

**In the continental U.S.A**

<p><b>DIAL TOLL FREE</b> 7 days a week, 24 hours a day <b>1-800-HITACHI</b> (1-800-448-2244) You must state your zip code when calling</p>
--

**In Canada**

<p>MONTREAL                      514-956-9882 TORONTO                        905-821-4545 VANCOUVER                    604-526-7881</p>
---