

IMPORTANT SAFEGUARDS

HITACHI

PROJECTION COLOR TV

61SBX01B 53SBX01B

OPERATING GUIDE

TABLE OF CONTENTS

IMPORTANT SAFEGUARDS	2
SAFETY TIPS	4
PICTURE CAUTIONS.....	9
ACCESSORIES.....	9
REMOTE CONTROL BATTERY INSTALLATION AND REPLACEMENT.....	11
HOW TO SET UP YOUR NEW HITACHI PROJECTION TV.....	11
HOOK-UP CABLES AND CONNECTORS	13
FRONT PANEL CONTROLS.....	15
FRONT PANEL JACKS AND CONNECTIONS.....	16
REAR PANEL JACKS.....	18
REAR SPEAKER TERMINAL CONNECTIONS.....	22
TIPS ON REAR PANEL CONNECTIONS	22
EXTERNAL AUDIO SOURCES.....	23
CONNECTING EXTERNAL VIDEO SOURCES	25
AUDIO SYSTEM SET-UP	29
PICTURE-IN-PICTURE (PIP).....	36
USING THE REMOTE TO CONTROL VCR FUNCTIONS.....	42
USING THE REMOTE TO CONTROL CABLE BOX FUNCTIONS.....	44
USING THE REMOTE TO CONTROL SATELLITE RECEIVER FUNCTIONS.....	45
USING THE REMOTE TO CONTROL DVD FUNCTIONS	47
USING THE REMOTE TO CONTROL ADDITIONAL AUDIO/VIDEO EQUIPMENT	48
CABLE/SATELLITE, VCR, AUDIO AND DVD CODES (CLU-573TSI and CLU-574TSI)	50
VCR BRANDS	50
DVD BRAND	53
CABLE BRAND	53
SATELLITE BRAND CODES	54
AMPLIFIER BRAND	54
CD BRAND.....	55
TAPE BRAND	55
ULTRATEC OSD.....	56
SET UP.....	59
CUSTOM.....	67
AUTO LINK	76
VIDEO	80
THEATER	85
INFO	94
CARE OF YOUR HITACHI PROJECTION TV AND YOUR.....	97
REMOTE CONTROL	97
RECEPTION PROBLEMS.....	98
USEFUL INFO.....	99

IMPORTANT SAFEGUARDS

NOTES.....	104
Back cover	105

IMPORTANT SAFEGUARDS

Follow all warnings and instructions marked on this projection television.



**CAUTION: TO REDUCE THE RISK OF ELECTRIC SHOCK,
DO NOT REMOVE COVER (OR BACK).
NO USER SERVICEABLE PARTS INSIDE.
REFER SERVICING TO QUALIFIED SERVICE PERSONNEL.**



The lightning flash with arrowhead symbol, within an equilateral triangle, is intended to alert the user to the presence of uninsulated "dangerous voltage" within the product's enclosure that may be of sufficient magnitude to constitute a risk of electric shock to persons.



The exclamation point within an equilateral triangle, is intended to alert the user to the presence of important operating and maintenance (servicing) instructions in the literature accompanying the appliance.

WARNING:

TO PREVENT FIRE OR SHOCK HAZARD, DO NOT EXPOSE THIS COLOR TELEVISION TO RAIN OR MOISTURE.

NOTE:

- There are no user serviceable parts inside the television.
- Model and serial numbers are indicated on back side of the television.
- This television is not intended for use in a computer room.



CAUTION: Adjust only those controls that are covered in the instructions, as improper changes or modifications not expressly approved by Hitachi could void the user's warranty.

CAUTION: TO PREVENT ELECTRIC SHOCK, MATCH WIDE BLADE OF PLUG TO WIDE SLOT, FULLY INSERT.

MODIFICATIONS: The FCC requires the user to be notified that any changes or modifications made to this device that are not expressly approved by Hitachi America, Ltd. Home Electronics Division may void the user's warranty.



POWER SOURCE:

This projection television is designed to operate on 120 volts 60Hz, AC current. Insert power cord into a 120 volt 60Hz outlet.

IMPORTANT SAFEGUARDS

TO PREVENT ELECTRIC SHOCK, DO NOT USE THE TELEVISION'S (POLARIZED) PLUG WITH AN EXTENSION CORD, RECEPTACLE, OR OTHER OUTLET UNLESS THE BLADES AND GROUND TERMINAL CAN BE FULLY INSERTED TO PREVENT BLADE EXPOSURE.

NEVER CONNECT THE TV TO 50Hz, DIRECT CURRENT, OR ANYTHING OTHER THAN THE SPECIFIED VOLTAGE.

NOTE: This television receiver will display television closed captioning ( or ), in accordance with paragraph 15.119 of the FCC rules.



CAUTION: Never remove the back cover of the television as this can expose you to very high voltages and other hazards. If the television does not operate properly, unplug the television and call your authorized dealer or service shop.

SAFETY TIPS

SAFETY TIPS

IMPORTANT SAFEGUARDS

SAFETY POINTS YOU SHOULD KNOW ABOUT YOUR HITACHI PROJECTION TELEVISION

CAUTION:

- Read all of these instructions.
- Save these instructions for later use.
- Follow all warnings and instructions marked on the television.

Our reputation has been built on the quality, performance, and ease of service of HITACHI televisions.

Safety is also foremost in our minds in the design of these units. To help you operate these products properly, this section illustrates safety tips which will be of benefit to you. Please read it carefully and apply the knowledge you obtain from it to the proper operation of your HITACHI television.

Please fill out your warranty card and mail it to HITACHI. This will enable HITACHI to notify you promptly in the improbable event that a safety problem should be discovered in your product model.

FOR YOUR PERSONAL SAFETY



1 This television set is equipped with a polarized alternating-current line plug (a plug having one blade wider than the other). This plug will fit into the power outlet only one way. This is a safety feature. If you are unable to insert the plug fully into the outlet, try reversing the plug. If the plug should still fail to fit, contact your electrician to replace your obsolete outlet. Do not defeat the safety purpose of the polarized plug.



2 When the power cord or plug is damaged or frayed, unplug this television set from the wall outlet and refer servicing to qualified service personnel.



3 Do not overload wall outlets and extension cords as this can result in fire or electric shock.



4 Do not allow anything to rest on or roll over the power cord, and do not place the television where the power cord is subject to traffic or abuse. This may result in a shock or fire hazard.

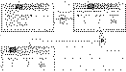

5 Do not attempt to service this television yourself as opening or removing covers may expose

SAFETY TIPS

you to dangerous voltage or other hazards. Refer all servicing to qualified service personnel.



6 Never push objects of any kind into this television set through the television cabinet's slots as they may touch dangerous voltage points or short out parts that could result in a fire or electric shock. Never spill liquid of any kind on the television.



7 If the television has been dropped or the cabinet has been damaged, unplug this television from the wall outlet and refer servicing to qualified service personnel.



8 If liquid has been spilled into this television set, unplug it from the wall outlet and refer service to qualified service personnel.



9 Do not subject your television to impact of any kind. Be careful not to damage the picture tube surface.



10 Unplug this television from the wall outlet before cleaning. Use a damp cloth for cleaning. Do not use liquid or aerosol cleaners.



11-1 Do not place this television on an unstable cart, stand, or table. The television may fall, causing serious injury to a child or an adult, and serious damage to the appliance. Use only with a cart or stand recommended by the manufacturer, or sold with the television. Wall or shelf mounting should follow the Wall/Shelf mounting manufacturer's instructions, and should use a mounting kit approved by the manufacturer.



11-2 An appliance and cart combination should be moved with care. Quick stops, excessive force, and uneven surfaces may cause the appliance and cart combination to overturn.

PROTECTION AND LOCATION OF YOUR TELEVISION

12 Do not use the television near water, for example, near a bathtub, washbowl, kitchen sink, or laundry tub, in a wet basement, or near a swimming pool, etc.

SAFETY TIPS



• Never expose the television to rain or water. If the set has been exposed to rain or water, unplug television from wall outlet and refer to qualified service personnel.

13 Choose a place where light (artificial or sunlight) does not shine directly on the screen.



14 Avoid dusty places. Accumulated dust inside the chassis may cause failure of the television when high humidity persists.



15 The television has slots, or openings in the cabinet for ventilation purposes which provide reliable operation of the receiver and protect the television from overheating. These openings must not be blocked or covered.

• Never cover the slots or openings with cloth or other material.



• Never block the bottom ventilation slots of the set by placing it on a bed, sofa, rug, etc.



• Never place the set near or over a radiator or heat generator.

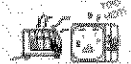

• Never place the television in a built-in enclosure unless proper ventilation provided.



PROTECTION AND LOCATION OF YOUR TELEVISION

16-1 If an outside antenna is connected to the television, be sure the antenna system is grounded so as to provide some protection against voltage surges and built up static charges. Section 810 of the National Electrical Code, NFPA No. 70-1975, provides information with respect to proper grounding of the mast and supporting structure, grounding of the lead-in wire to an antenna discharge unit, size of grounding conductors, location of antenna discharge unit connection to grounding electrode, and requirements for the grounding electrode.

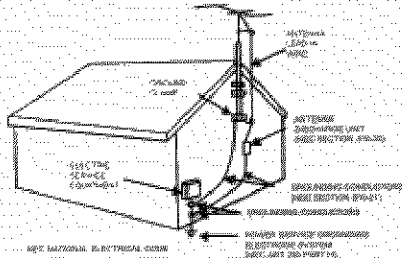

EXAMPLE OF ANTENNA GROUNDING AS PER NATIONAL ELECTRICAL CODE INSTRUCTIONS.

16-2 **Note to CATV system installer:** (Only for television with CATV reception) This reminder is provided to call the CATV system installer's attention to Article 820-40 of the NEC that

SAFETY TIPS

provides guidelines for proper grounding and, in particular, specifies that the cable ground shall be connected to the grounding system of the building, as close to the point of cable entry as practical.



17 An outside antenna system should not be located in the vicinity of overhead power lines or other electrical lights or power circuits, or where it can fall into such power lines or circuits. When installing an outside antenna system, extreme care should be taken to keep from touching such power lines or circuits as contact with them might be fatal.

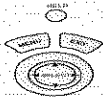

18 For added protection for the television during a lightning storm, or when it is unused for long periods of time, unplug it from the wall outlet and disconnect antenna. This will prevent damage due to lightning and power-line surges.

OPERATION OF YOUR TELEVISION



19 This television should be operated only from the type of power source indicated on the marking label. If you are not sure of the type of power supply at your home, consult your dealer or local power company. For televisions designed to operate from battery power, refer to the operating instructions.



20 If the television does not operate normally by following the operating instructions, unplug the television from the wall outlet and refer servicing to qualified service personnel. Adjust only those controls that are covered in the instructions as improper adjustment of other controls may result in damage and will often require extensive work by a qualified service technician to restore the television to normal operation.



21 If your television is to remain unused for a period of time, (such as when going on a holiday), turn the television OFF and unplug it from the wall outlet.

IF THIS TELEVISION DOES NOT OPERATE PROPERLY



22 If you are unable to restore normal operation by following the detailed procedure in your operating instructions, do not attempt any further adjustment. Unplug the television and call your dealer or service technician.

23 Whenever the television is damaged or fails, or if there is a distinct change in performance that indicates a need for service, unplug the television and have it checked by a qualified service technician.

SAFETY TIPS



24 It is normal for some televisions to make occasional snapping or popping sounds, particularly when being turned on or off. If the snapping or popping is continuous or frequent, unplug the set and consult your dealer or service technician.

FOR SERVICING AND MODIFICATION

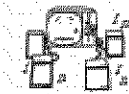

25 Do not use attachments not recommended by the television manufacturer as they may cause hazards.

26 If replacement parts are required, be sure the service technician has used replacement parts specified by the manufacturer that have the same characteristics as the original part. Unauthorized substitutions may result in fire, electric shock, or other hazards.



27 Upon completion of any service or repairs to the television, ask the service technician to perform routine safety checks to determine that the television is in safe operating condition.

PICTURE CAUTIONS

PICTURE CAUTIONS

Picture Burn Prevention

- Continuous on-screen displays such as video games, stock market quotations, computer generated graphics, and other fixed (non-moving) patterns can cause permanent damage to projection television receivers. Such "PATTERN BURNS" constitute misuse and are **NOT COVERED** by your HITACHI Factory Warranty.
- When using Picture-in-Picture function, the sub-picture should not be left permanently in one corner of the screen or a "PATTERN BURN" may develop over a long period of time.

Public Viewing of Copyrighted Material

Public viewing of programs broadcast by TV stations and cable companies, as well as programs from other sources, may require prior authorization from the broadcaster or owner of the video program material.

pg. 5-24 FIRST TIME USE

ACCESSORIES

Check to make sure that you have the following accessories before disposing of the packing material.

ACCESSORIES

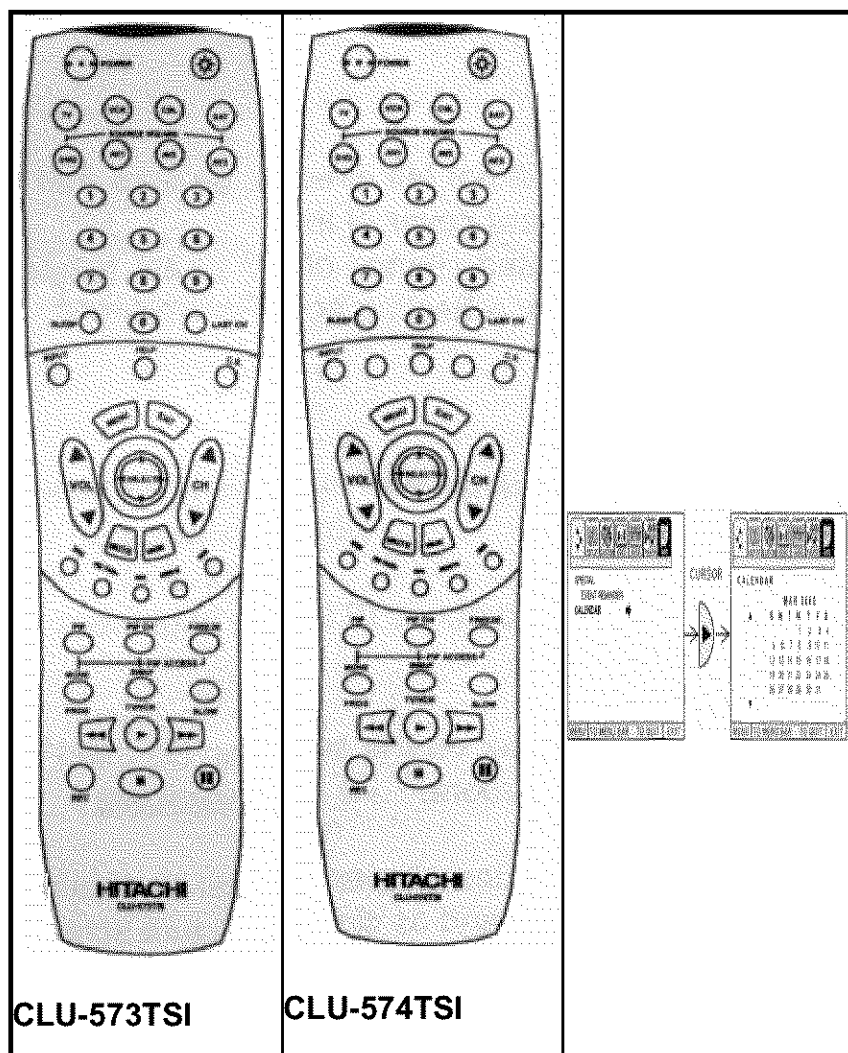

1. Remote Control Unit CLU-573TSI (Part No. HL01323) or CLU 574TSI (Part No. HL01324).
2. Two "AA" size, 1.5V batteries (For Remote Control Unit).

REMOTE CONTROL BATTERY INSTALLATION AND REPLACEMENT

REMOTE CONTROL BATTERY INSTALLATION AND REPLACEMENT

1. Open the battery cover of the remote control by pushing the notched part of the cover with your fingers and pulling the cover off.
2. Insert two new "AA" size batteries for the remote control. When replacing old batteries, push them towards the springs and lift them out.
3. Match the batteries to the (+) and (-) marks in the battery compartment.
4. Replace the cover.

BOTTOM VIEW

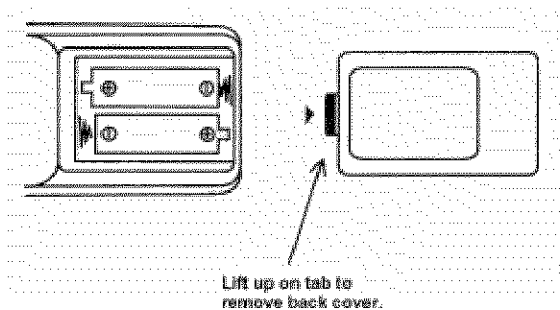

HOW TO SET UP YOUR NEW HITACHI PROJECTION TV

ANTENNA

Unless your TV is connected to a cable TV system or to a centralized antenna system, a good outdoor color TV antenna is recommended for the best performance. However, if you are located in an exceptionally good signal area that is free from interference and multiple image ghosts, an indoor antenna may be sufficient.

LOCATION

Select an area where sunlight or bright indoor illumination will not fall directly on the picture screen. Also, be sure that the location selected allows a free flow of air to and from the perforated back cover of the set.

To avoid cabinet warping, cabinet color changes, and increased chance of set failure, do not place the TV where temperatures can become excessively hot, for example, in direct sunlight or near a heating appliance, etc.

VIEWING

The major benefit of the HITACHI Projection Television is its large viewing screen. To see this large screen at its best, test various locations in the room to find the optimum spot for viewing.

The best picture is seen by sitting directly in front of the TV and about 10 to 18 feet from the screen. Picture brightness decreases as the viewer moves to the left and right of the receiver.

HOW TO SET UP YOUR NEW HITACHI PROJECTION TV

During daylight hours, reflections from outside light may appear on the screen. If so, drapes or screens can be used to reduce the reflection or the TV can be located in a different section of the room.

If the TV's audio output will be connected to a Hi-Fi system's external speakers, the best audio performance will be obtained by placing the speakers equidistant from each side of the receiver cabinet and as close as possible to the height of the picture screen center. For best stereo separation, place the external speakers at least four feet from the side of the TV, place the surround speakers to the side or behind the viewing area. Differences in room sizes and acoustical environments will require some experimentation with speaker placement for best performance.

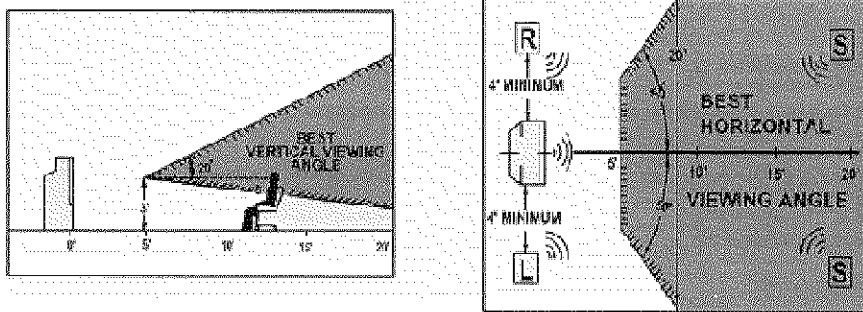

CAUTION: Magnetic fields, such as those of external speakers, may cause the picture to distort if they are placed too close to the television. Move the magnetic field source away from the television until there is no picture distortion.

HOOK-UP CABLES AND CONNECTORS

HOOK-UP CABLES AND CONNECTORS

Most video/audio connections between components can be made with shielded video and audio cables that have phono connectors. For best performance, video cables should use 75-Ohm coaxial shielded wire. Cables can be purchased from most stores that sell audio/video products. Below are illustrations and names of common connectors. Before purchasing any cables, be sure of the output and input connector types required by the various components and the length of each cable.



300-Ohm Twin Lead Connector

This outdoor antenna cable must be connected to an antenna adaptor (300-Ohm to 75-Ohm).

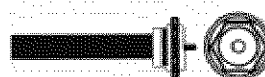

"F" Type 75-Ohm Coaxial Antenna Connector

For connecting RF signals (antenna or cable TV) to the antenna jack on the television.



Phono Connector

Used on all standard video and audio cables which connect to inputs and outputs located on the television's rear jack panel and front control panel.

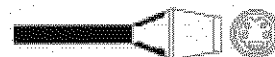

S-Video (Super Video) Connector

This connector is used on camcorders, VCRs, and laserdisc players with an S-Video feature in place of the standard video cable to produce a high-quality picture.

ANTENNA CONNECTIONS TO REAR JACK PANEL

VHF (75-Ohm) antenna/CATV (Cable TV)

When using a 75-Ohm coaxial cable system, connect the outdoor antenna or CATV coaxial cable to the ANT A (75-Ohm) terminal. If you have a second antenna or cable TV system, connect the coaxial cable to the ANT B terminal.

To outdoor antenna or CATV cable

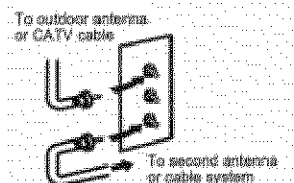

VHF (300-Ohm) antenna/UHF antenna

When using a 300-Ohm twin lead from an outdoor antenna, connect the VHF or UHF antenna leads to screws of the VHF or UHF adaptor. Plug the adaptor into the antenna terminal on the TV.

To outdoor VHF or UHF Antenna

HOOK-UP CABLES AND CONNECTORS

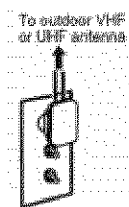

When both VHF and UHF antennas are connected

Attach an optional antenna cable mixer to the TV antenna terminal, and connect the cables to the antenna mixer. Consult your dealer or service store for the antenna mixer.

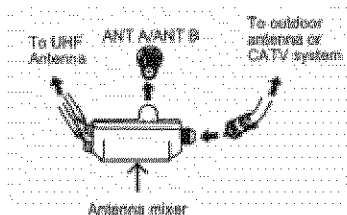

FRONT PANEL CONTROLS

FRONT PANEL CONTROLS

FRONT VIEW

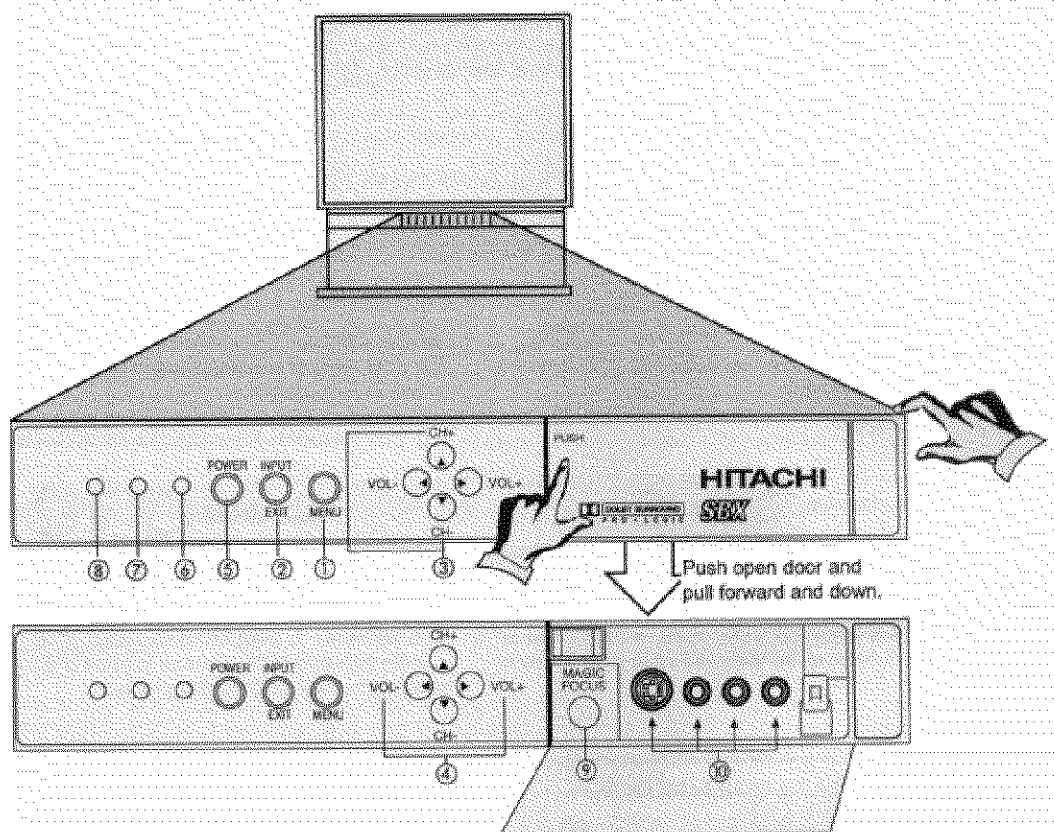

MENU Button

This button allows you to enter the MENU, making it possible to set TV features to your preference without using the remote.

INPUT/EXIT button

Press this button to select the current antenna source, VIDEO: 1, 2, 3, or alternate antenna source. Your selection is shown in the top right corner of the screen. This button also serves as the EXIT button when in MENU mode.

CHANNEL Selector

Press these buttons until the desired channel appears at the top right corner of the TV screen. These buttons also serve as the cursor down (▼) and up (▲) buttons when in MENU mode.

VOLUME Level

Press these buttons for your desired sound level. The volume level will be displayed on the TV screen. These buttons also serve as the cursor left (◀) and right (▶) buttons when in MENU mode.

POWER Button

Press this button to turn the TV on or off.

FRONT PANEL JACKS AND CONNECTIONS

NOTES:

Your HITACHI Projection TV will appear to be turned OFF if there is no video input when VIDEO: 1, 2 or 3 is selected. Check the Power Light to make sure the TV is turned off when not in use.

To see an auto-demonstration of the on-screen displays with HELP text displayed, press and hold the POWER button on the TV set for approximately five seconds. Press the POWER button on the TV again to end the auto-demonstration.

POWER light

You will see a red light when the TV is turned on.

AI (Artificial Intelligence) sensor

The artificial Intelligence sensor will make automatic picture adjustments depending on the amount of light in the room to give the best picture. (See page 55.)

REMOTE CONTROL Sensor

Point your remote control at this area when selecting channels, adjusting volume, etc.

MAGIC FOCUS

Use this button to adjust your picture quality to optimum performance. (See page 44.)

FRONT INPUT JACKS (for VIDEO: 3)

Use these audio/video jacks for a quick hook-up from a camcorder or VCR to instantly view your favorite show or new recording. Press the INPUT button until VIDEO: 3 appears in the top right corner of the TV screen. If you have mono sound, insert the audio cable into the left audio jack.

FRONT PANEL JACKS AND CONNECTIONS

The front panel jacks are provided as a convenience to allow you to easily connect a camcorder or VCR as shown in the following examples.

FRONT PANEL JACKS AND CONNECTIONS

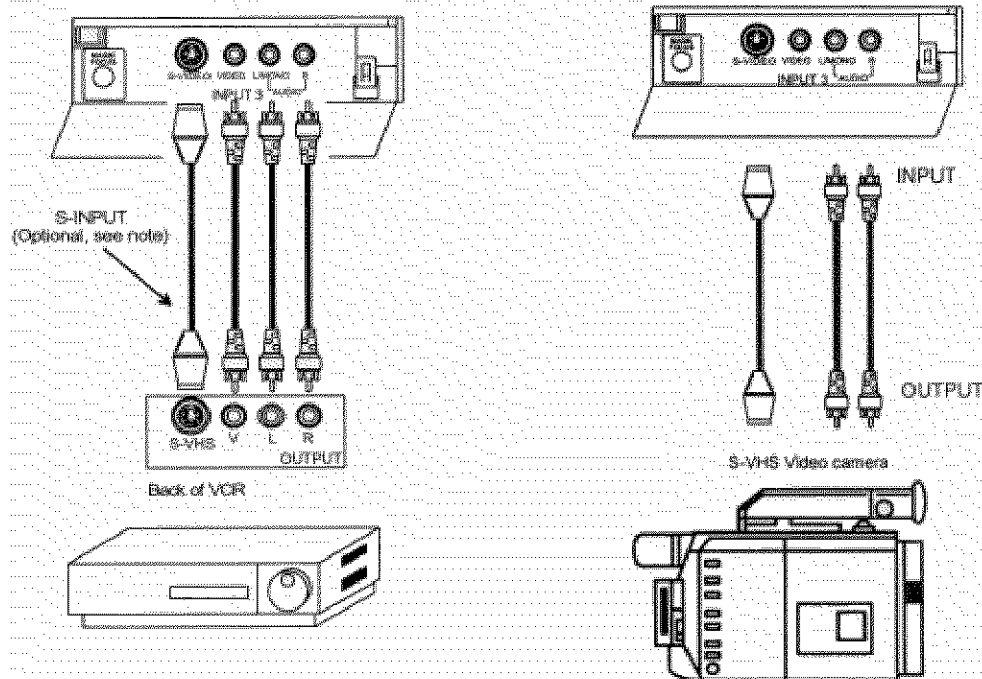

NOTE:

Completely insert connection cord plugs when connecting to front panel jacks. If you do not, the played back picture may be abnormal. If you have a S-VHS VCR, use the S-INPUT cable in place of the standard video cable. If you have a mono VCR, insert the audio cable into the left channel jack of your TV.

REAR PANEL JACKS

REAR PANEL JACKS

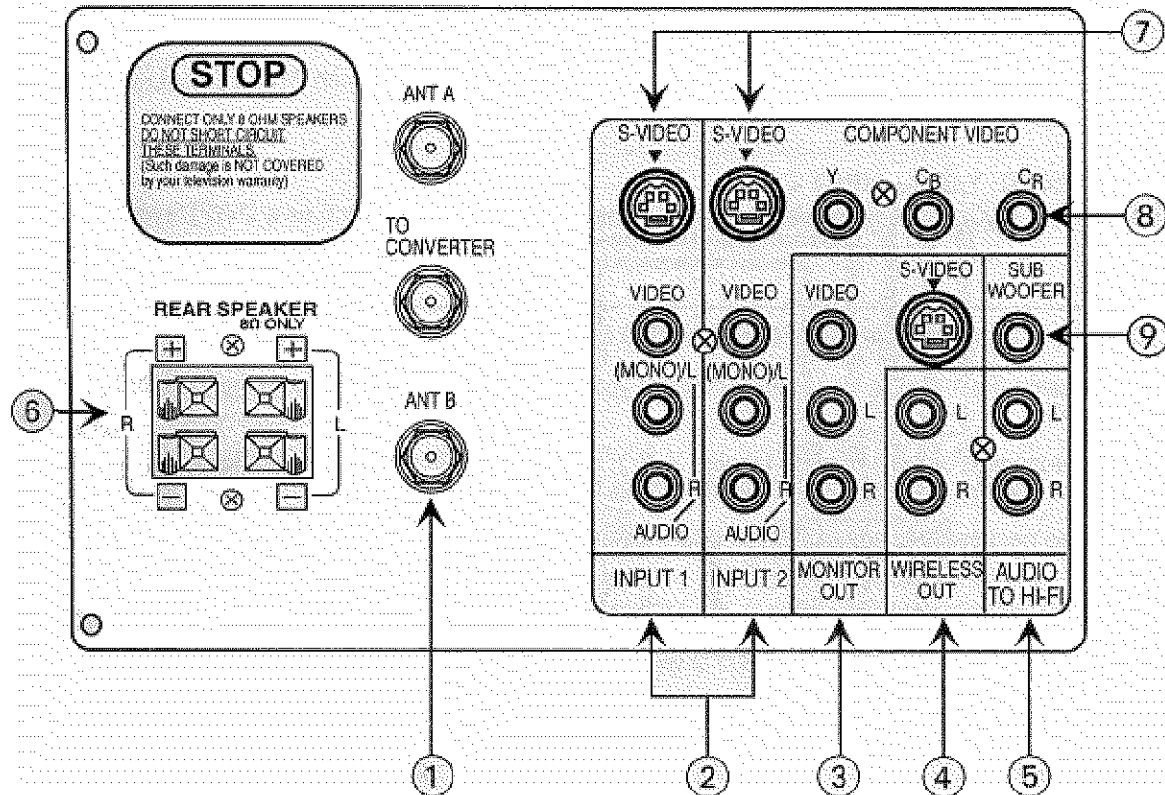

Antenna Input/Output

The remote control allows you to switch between two separate 75-Ohm RF antenna inputs, ANT A and ANT B. ANT A input can be displayed as a main picture or sub-picture. ANT B can only be displayed as a main picture. (ANT B cannot be displayed as a sub-picture.) The antenna output labeled "TO CONVERTER" allows the ANT A connection to pass directly to a different source such as a cable box, when ANT B is displayed as a main picture.

Audio/Video Inputs 1 and 2

The INPUT button will step through each video source and antenna source input each time it is pressed. Use the audio and video inputs to connect external devices, such as VCRs, camcorders, laserdisc players, DVD players, etc. (If you have mono sound, insert the audio cable into the left channel jack).

NOTE: You may use VIDEO, S-VIDEO, or COMPONENT VIDEO: Y-CB-CR inputs to connect to INPUT 2, but note that only one of these may be used at a time.

Monitor Out

These jacks provide fixed audio and video signals which are used for recording. To have S-VIDEO, S-VIDEO signal needs to be input to INPUT 1 or INPUT 2, or INPUT 3.

(4) WIRELESS OUT

These jacks provide variable audio output to a set of wireless speakers. They can also be

REAR PANEL JACKS

used for another stereo system amplifier. With this connection, the audio can be controlled by the television's main volume and also by an independent volume feature found in the THEATER-WIRELESS SOUND menu.

(5) **AUDIO TO HI-FI**

These jacks provide variable audio output to a separate stereo amplifier. With this connection, the audio to the stereo can be controlled by the television's main volume. Use these jacks for the SURROUND Left and Right channels. (see page 20)

(6) **REAR SPEAKER Terminals**

These terminals are used to connect external speaker, which are used for the surround sound feature. The volume level is controlled by the television's main volume and also by an independent rear volume feature found in the THEATER-SURROUND menu. Use speaker with 8-Ohm impedance only.

(7) **S-VIDEO INPUTS 1 and 2**

Inputs 1 and 2 provide S-Video (Super Video) jacks for connecting equipment with S-VIDEO output capability.

(8) **Component: Y-CB-CR INPUT 2**

INPUT 2 provides Y-CB-CR jacks for connecting equipment with this capability, such as a DVD.

REAR PANEL JACKS

NOTES:

DO NOT connect standard VIDEO or S-VIDEO to INPUT 2 when using Y-CB-CR input.

When using the Y-CB-CR input jacks, connect your components audio output to the TV's INPUT 2 Left and Right Audio input jacks.

Your component outputs may be labeled Y, B-Y, and R-Y. In this case, connect the components B-Y output to the TV's CB input and the components R-Y output to the TV's CR input.

It may be necessary to adjust TINT to obtain optimum picture quality when using the Y-CB-CR inputs. (See pages 54 and 55.)

To ensure no copyright infringement, the MONITOR OUT output will be abnormal, when using the Y-CB-CR jacks.

When using the Y-CB-CR jacks, INPUT 2 will be viewed as a blank PIP sub-picture. (see page 26)

(9) SUB WOOFER

This jack provides variable audio output to a sub-woofer accessory. With this connection, the audio can be controlled by the television's main volume and also by an independent sub-woofer feature found in the THEATER-SUB WOOFER menu.

REAR PANEL JACKS

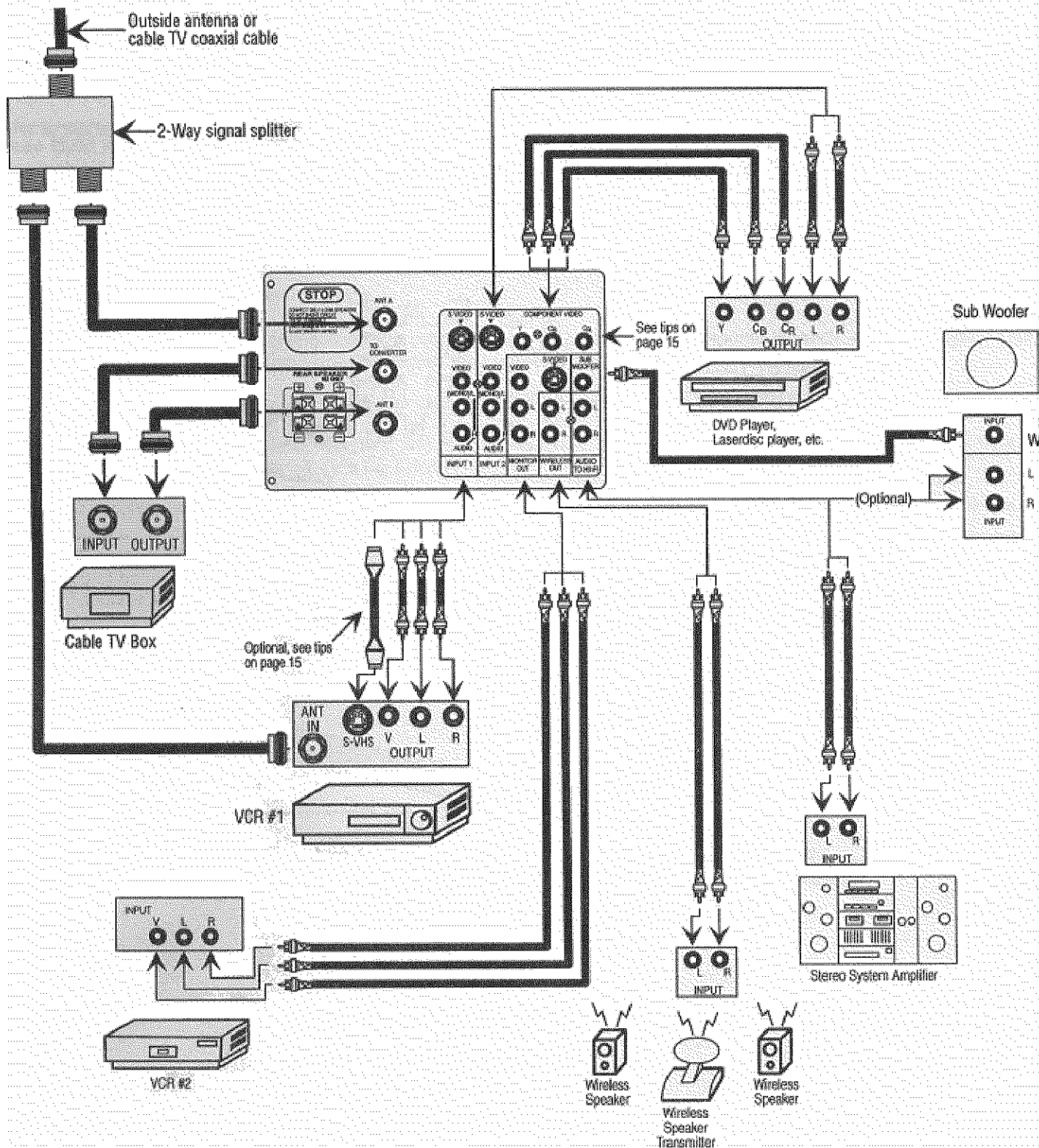

Typical full feature setup. Follow connections that pertain to your personal entertainment system.

REAR SPEAKER TERMINAL CONNECTIONS

REAR SPEAKER TERMINAL CONNECTIONS

CONNECT AFTER TURNING THE POWER TO THE TV OFF.

Press the Right Speaker red button and insert the positive (+) lead wire into the hole next to the button. Once the wire is in place, pull the red button back to original position and the wire is locked into place. In the same manner, press the Right Speaker black button and insert the negative (-) lead wire. Repeat this procedure for the Left Speaker.



CAUTION: Do not short speaker terminal, (do not connect a wire directly across any two terminals). This could cause damage to your audio outputs or other damage to your TV.

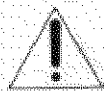
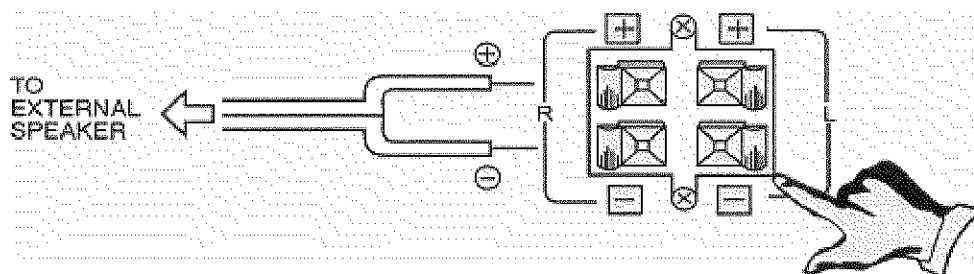

CAUTION: Do not connect speakers simultaneously to the REAR SPEAKER terminal of the Projection TV and an external amplifier. This could damage both the TV and the speakers. Your TV was designed to use 8-Ohm speakers only. Any other type may degrade the audio performance of your entertainment system..

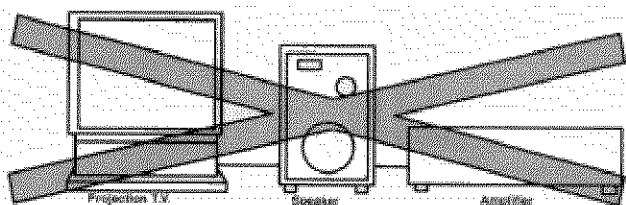

TIPS ON REAR PANEL CONNECTIONS

TIPS ON REAR PANEL CONNECTIONS

S-Video connections are provided for high performance laserdisc players, VCRs etc., that have this feature. Use these connections in place of the standard video connection if your device has this feature.

If your device has only one audio output (mono sound), connect it to the left audio jack on the TV.

EXTERNAL AUDIO SOURCES

Refer to the operating guide of your other electronic equipment for additional information on connecting your hook-up cables.

A single VCR can be used for VCR #1 and VCR #2, but note that a VCR cannot record its own video or line output. (INPUT 1 in example on page 13.) Refer to your VCR operating guide for more information on line input-output connection.

You may use VIDEO, S-VIDEO, or COMPONENT VIDEO: Y-CB-CR inputs to connect to INPUT 2, but only one of these may be used at a time.

Connect only 1 component to each input jack.

COMPONENT VIDEO: Y-CB-CR connections are provided for high performance components, such as DVD players. Use these connections in place of the standard video connection if your device has this feature.

When using the Y-CB-CR input jacks, connect your components audio output to the TV's INPUT 2 Left and Right Audio input jacks.

Your component outputs may be labeled Y, B-Y, and R-Y. In this case, connect the components B-Y output to the TV's CB input and the components R-Y output to the TV's CR input.

It may be necessary to adjust TINT to obtain optimum picture quality when using the Y-CB-CR inputs. (See pages 54 and 55.)

To ensure no copyright infringement, the MONITOR OUT output will be abnormal, when using Y-CB-CR jacks.

When using the Y-CB-CR jacks, INPUT 2 will be viewed as a blank PIP sub-picture. (see page 26)

EXTERNAL AUDIO SOURCES

CONNECTING EXTERNAL AUDIO AMPLIFIER

EXTERNAL AUDIO SOURCES

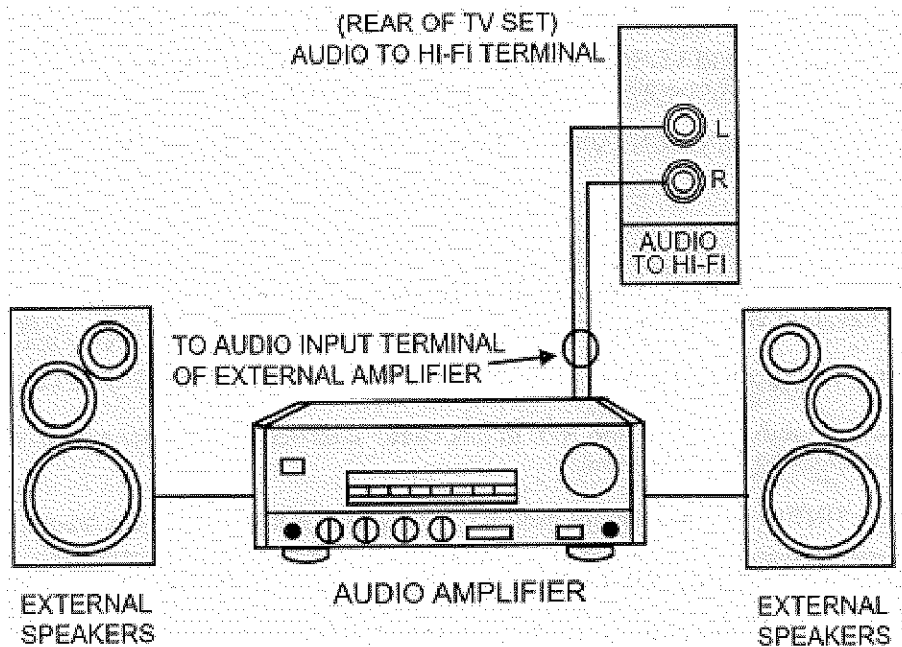

NOTES: To prevent damage to the speaker and distorted sound, set the volume control of the audio amplifier lower and adjust the sound using the remote control for the TV set.

Do not connect speakers simultaneously to the REAR SPEAKER terminal of the Projection TV and an external amplifier.

CONNECTING EXTERNAL VIDEO SOURCES

CONNECTING EXTERNAL VIDEO SOURCES

The exact arrangement you use to connect the VCR, camcorder, laserdisc player, DVD player or HDTV Set Top Box to your TV set is dependent on the model and features of each component. Check the owner's manual of each component for the location of video and audio inputs and outputs.

The following connection diagrams are offered as suggestions. However, you may need to modify them to accommodate your particular assortment of components and features. For best performance, video and audio cables should be made from coaxial shielded wire.

Before Operating External Video Source

The input mode is changed every time the INPUT button is pressed as shown below. Connect an external source to the INPUT terminal, then press the INPUT button as necessary to view the input source. (See page 24.)

INPUT MODE SELECTION ORDER

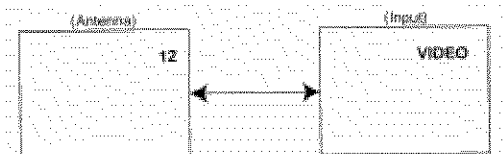

NOTE: When TV is set to VIDEO and a video signal is not received from the VIDEO INPUT jack on the jack panel of the TV (i.e., VCR/laserdisc player, etc. is not connected or the video device is OFF), the set will appear to be OFF.

CONNECTING A MONAURAL AUDIO VCR OR LASERDISC PLAYER

1. Connect the cable from the VIDEO OUT of the VCR or the laserdisc player to the INPUT (VIDEO) jack on the TV set below.
2. Connect the cable from the AUDIO OUT of the VCR or the laserdisc player to the INPUT (MONO)/L(AUDIO) jack.
3. Press the INPUT button to view the program from the VCR or laserdisc player. The VIDEO mode disappears automatically after approximately eight seconds.
4. Press the INPUT button to return to the previous channel.

CONNECTING EXTERNAL VIDEO SOURCES

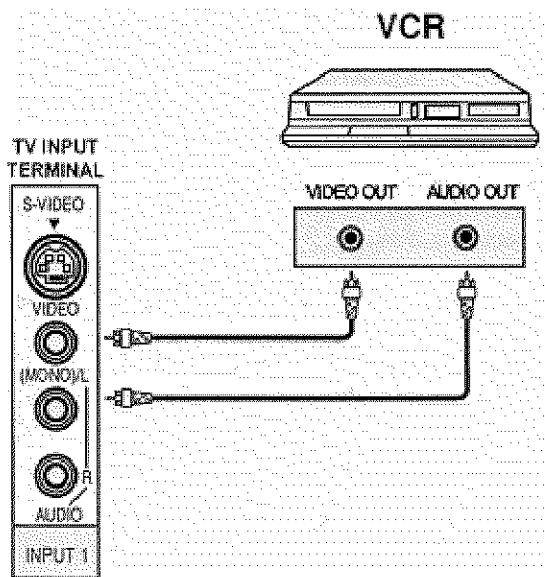

CONNECTING EXTERNAL VIDEO SOURCES

CONNECTING A STEREO VCR OR STEREO LASERDISC PLAYER

1. Connect the cable from the AUDIO OUT of the VCR or the laserdisc player to the INPUT (VIDEO) jack on the TV set below.
2. Connect the cable from the AUDIO OUT R of the VCR or the laserdisc player to the INPUT (AUDIO/R) jack.
3. Connect the cable from the AUDIO OUT L of the VCR or the laserdisc player to the INPUT (AUDIO/L) jack.
4. Press the INPUT button to view the program from the VCR or laserdisc player. The mode VIDEO disappears automatically after approximately eight seconds.
5. Press the INPUT button to return to the previous channel.

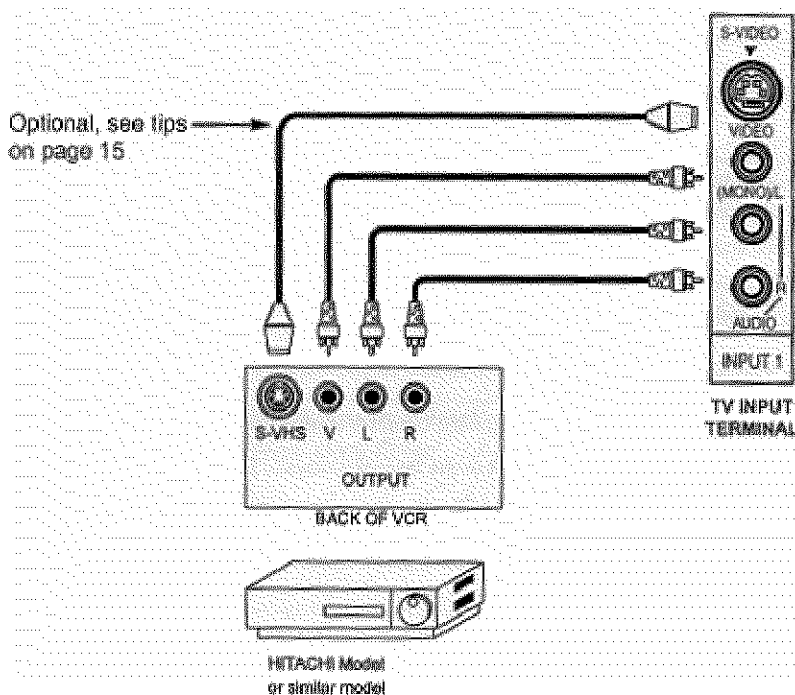

NOTES:

Completely insert the connection cord plugs when connecting to rear panel jacks. The picture that is played back will be abnormal if the connection is loose.

A single VCR can be used for VCR #1 and VCR #2, but note that a VCR cannot record its own video or line output. (INPUT 1 in example on page 13) Refer to your VCR operating guide for more information on line input-output connections.

CONNECTING A LASERDISC PLAYER OR DVD PLAYER TO INPUT 2.

1. Connect the cable from the Y OUT of the Laserdisc or the DVD player to the INPUT 2 (Y) jack as shown on the TV set below.
2. Connect the cable from the CB OUT or B-Y OUT of the Laserdisc or the DVD player to the INPUT 2 (CB) jack, as shown on the TV set below.

CONNECTING EXTERNAL VIDEO SOURCES

3. Connect the cable from the CR or R-Y OUT or B-Y of the Laserdisc or the DVD player to the INPUT 2 (CR) jack, as shown on the TV set below.
4. Connect the cable from the AUDIO OUT R of the Laserdisc or DVD player to the INPUT 2 (AUDIO/R) jack.
5. Connect the cable from the AUDIO OUT L of the Laserdisc or DVD player to the INPUT 2 (AUDIO/L) jack.
6. Press the INPUT button until VIDEO:2 appears, to view the program from the Laserdisc or DVD player. The VIDEO:2 icon disappears automatically after approximately eight seconds.
7. Press the INPUT button to return to the previous channel.

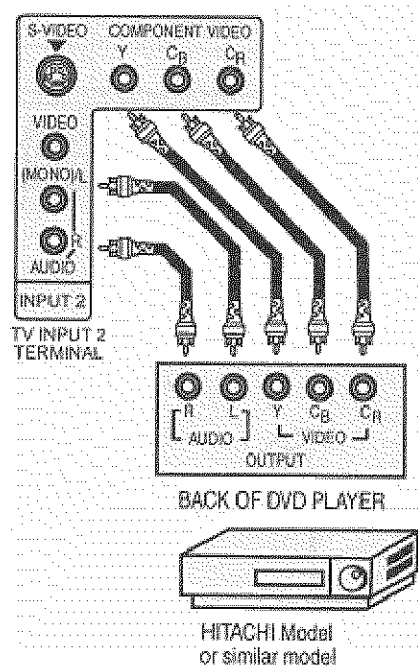

NOTES:

Completely insert the connection cord plugs when connecting to rear panel jacks. The picture that is played back will be abnormal if the connection is loose.

See Page 15 for tips on REAR PANEL CONNECTIONS.

AUDIO SYSTEM SET-UP

AUDIO SYSTEM SET-UP

Match the numbers below to the diagrams for speaker placement and refer to the table on page 21 for the different surround sound requirements. (See page 59 for SURROUND functions.)

The television's internal speakers.

The television's internal center channel speakers, which are on only when the television is in SURROUND-PRO LOGIC, or SURROUND-DOLBY 3 STEREO mode.

(3) These speakers are connected to a separate audio amplifier. Use the AUDIO TO HI-FI output on the TV.

(4) These speakers are connected to the rear speaker 8 Ohm output on the TV.

(5) These speakers are controlled by a wireless speaker transmitter. Use the WIRELESS OUT output on the TV.

(6) This sub woofer is connected to the SUB WOOFER output on the TV.

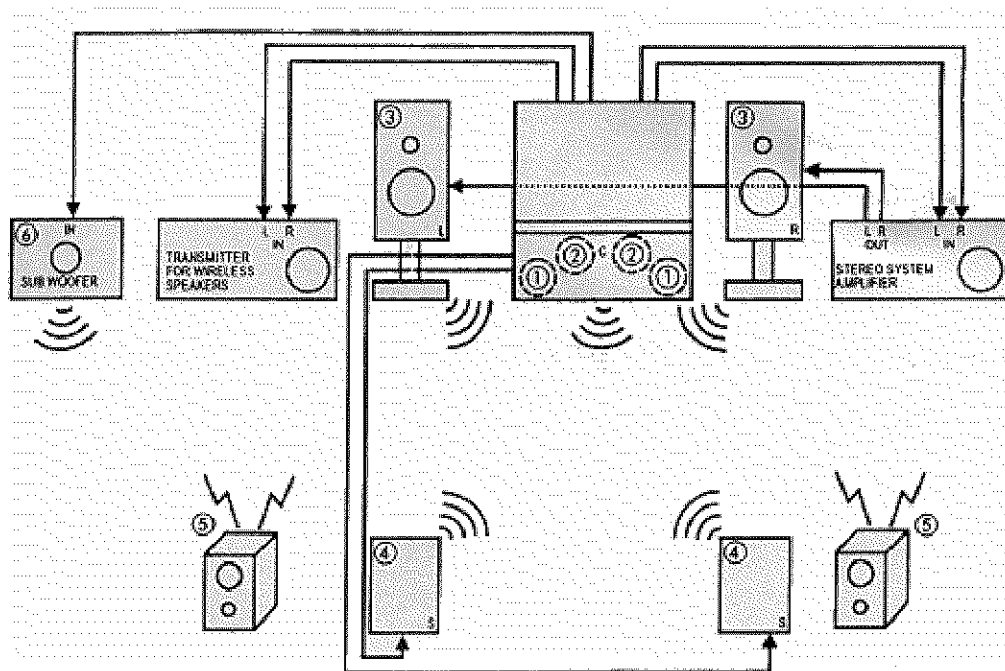

SURROUND FEATURE	REQUIRED CONNECTION	OPTIONAL CONNECTION	EFFECT
OFF	(1)	(3) (5) (6)	Receive mono and stereo sound.
HALL	(1) (4)	(3) (5) (6)	Gives the listener concert hall sound.

AUDIO SYSTEM SET-UP

MATRIX	(1) (4)	(3) (5) (6)	Listener has feeling of being at a stadium.
DOLBY PRO LOGIC	(1) (2) (4)	(3) (5) (6)	Movie theater reproduction, with separate left, center, right, and surround speakers.
DOLBY PRO LOGIC* (TV AS CENTER)	(2) (3) (4)	(5) (6)	Movie theater reproduction, with separate left, center, right, and surround channels, with left and right channels added to audio amplifier speakers to improve sound clarity and spatial positioning.
DOLBY 3 STEREO (NORMAL)	(1) (2)	(3) (5) (6)	Movie theater reproductions, surround channel added to left and right audio amplifier speakers.
DOLBY 3 STEREO (TV AS CENTER)	(2) (3)	(5) (6)	Movie theater reproduction, surround channel added to left and right audio amplifier speakers.

Left and right speakers are connected (3), and the internal speakers (1) can be disabled, creating better separation between left, center and right channels. The center channel audio will be heard from (2).

AUDIO SYSTEM SET-UP

THE GENIUS REMOTE CONTROL (CLU-573TSI and CLU-574TSI)

In addition to controlling all the functions on your HITACHI Projection TV, the new remote is designed to operate different types of VCRs, CATV (Cable TV) converters, satellite receivers, DVD players, and other audio/video equipment with one touch. Basic operation keys are grouped together in one area.

To operate your TV, point the remote control at the remote sensor of the TV and press the TV button. The TV button will blink, indicating that the remote will now control your television.

To operate your VCR, point the remote at the remote sensor of the VCR and press the VCR button. The VCR button will blink, indicating that the remote will now control your VCR. (See page 29 for instructions on how to program the remote to control your VCR.)

To operate your cable box, point the remote at the remote sensor of the cable box and press the CABLE (CBL) button. The CBL button will blink, indicating that the remote will now control your cable box. (See page 30 for instructions on how to program the remote to control your cable box.)

To operate your satellite receiver, point the remote at the remote sensor of the satellite receiver and press the SATELLITE (SAT) button. The SAT button will blink, indicating that the remote will now control your satellite receiver. (See page 31 for instructions on how to program the remote to control your satellite receiver.)

To operate your DVD player, point the remote at the remote sensor of the DVD player and press the DVD button. The DVD button will blink, indicating that the remote will now control your DVD player. (See page 32 for instruction on how to program the remote to control your DVD player.)

To operate additional audio/video equipment, point the remote at the remote sensor of the component and press the AV1, AV2 or AV3 button. This button will blink, indicating that the remote will now control the desired component. (See page 33 for instructions on how to program the remote to control additional audio/video equipment.)

AUDIO SYSTEM SET-UP

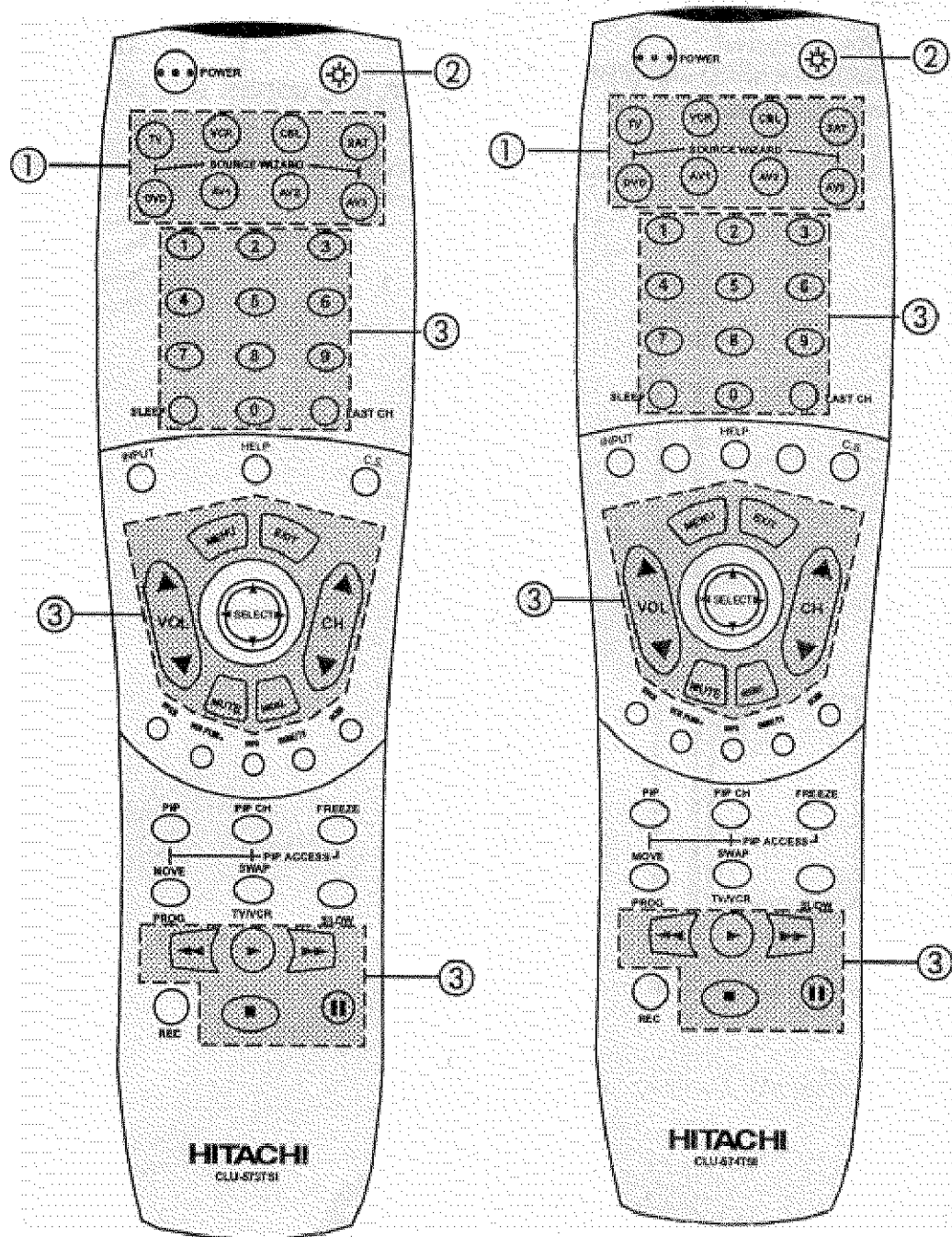

(1) These buttons allow the remote to control your TV, VCR, cable box, satellite receiver, DVD player, or other audio/video equipment depending on which mode is chosen, as explained above.

(2), (3) LIGHT BUTTON

When you are in a dark room, press the light button (2) on the side of the remote to light up the buttons shown in (3) and the source button will blink. The light will stay on for about 8 seconds if the light button is not pressed again. These buttons will not appear to light if the room is too bright.

[Click here for CLU-573TS1.](#)

[Click here for CLU-574TS1.](#)

(1) POWER Button

Press this button to turn the TV set on or off when the remote is in TV mode. (See page 22 for instructions on how to set the remote control to TV mode.) If a SPECIAL EVENT REMINDER is set, it will be displayed when the TV is first turned on. (see page 64)

AUDIO SYSTEM SET-UP

(2) TV button

When the TV button is pressed, it will blink, to indicate the remote is in TV mode.

(3) VCR button

When the VCR button is pressed, it will blink to indicate the remote is in VCR mode. (See page 29)

(4) CABLE button

When the CABLE button is pressed, it will blink to indicate the remote is in CABLE mode. (See page 30)

(5) SAT button

When the SAT button is pressed, it will blink, to indicate the remote is in satellite mode. (See page 31)

(6) DVD button

When the DVD button is pressed, it will blink, to indicate the remote is in DVD mode. (See page 32)

(7) AV1, AV2, AV3 buttons

When pressed, each of these buttons will blink to indicate the remote is in Audio/Video mode.

(19) VOLUME, MUTE button

Press the VOLUME up (▲) or down (▼) button until you obtain the desired sound level.

To reduce the sound to one half of normal volume (SOFT MUTE) to answer the telephone, etc., press the MUTE button. Press the MUTE button again to turn the sound off completely (MUTE). To restore the sound, press the MUTE button one more time, or press the VOLUME up (▲) button.



(9) CHANNEL selector buttons

CHANNEL selector buttons are used to set FAMILY FAVORITES, CHANNEL MEMORY, etc. Enter one, two or three numbers to select channels. Enter "0" first for channels 1 to 9. For channels 100 and above, press the "1" button, wait until two dashes appears next to the channel display on your TV, then enter the remaining two numbers using the number buttons. Channel selection may also be performed by pressing CH up (▲) or down (▼).

NOTE: The TV may not receive some channels if you are not in the correct SIGNAL SOURCE mode. (See page 39.)

(10) SLEEP button

Press this button to display the sleep timer in the lower left corner of the screen. Every subsequent press of this button will add 15 minutes to this timer, up to a maximum of three hours. Once set, use RECALL when you want to view time remaining. If the SLEEP button is

AUDIO SYSTEM SET-UP

pressed while the timer is set, it will reset to the original condition.

(11) LAST CHANNEL (LAST CH) button

Use this button to select between the last two channels viewed. (Good for watching two sporting events, etc.)

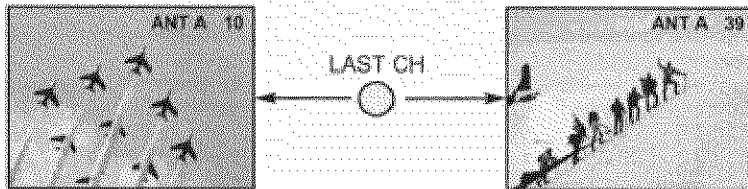

(12) INPUT button

The INPUT button will select between antenna signal and the three sets of video input jacks each time the button is pressed. If the Picture-in-Picture is on, the INPUT button will select between the three sets of video input jacks and both antenna sources when main channel is chosen with the PIP CH button. If the sub-picture is chosen, the INPUT button will select between the three sets of video input jacks and the ANT A source (ANT B source cannot be displayed as a PIP sub-picture and COMPONENT VIDEO: Y-CB-CR INPUT 2 source will be displayed as a blank PIP Sub picture.)

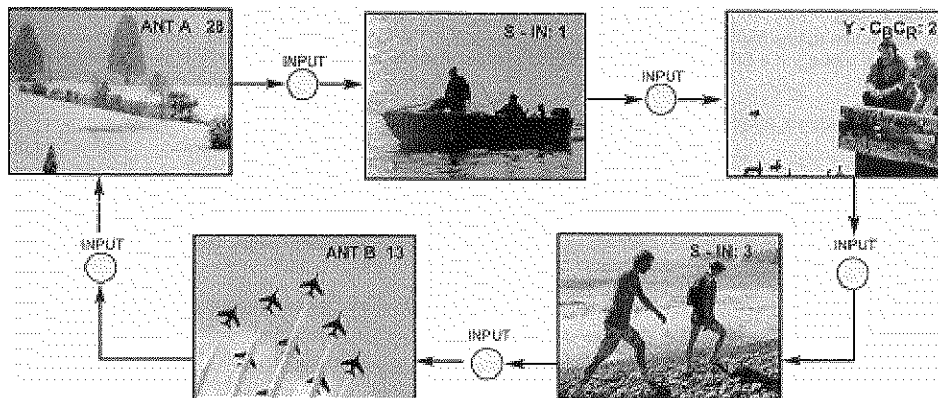

(13) HELP button

Press this button when a menu is displayed to view HELP text, which gives a description of the displayed menu. The HELP text will be displayed every time a MENU is displayed, until this button is pressed again.

AUDIO SYSTEM SET-UP

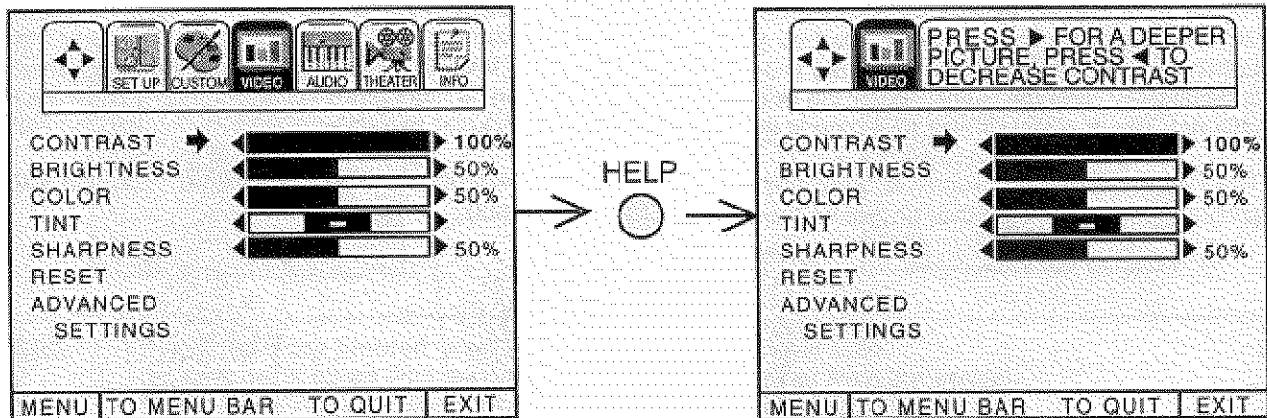

(14) COMMERCIAL SKIP (S.C.) button

Press the this button repeatedly to select channel skip time (30-180 seconds) when no menu is displayed and the TV will tune to the last channel viewed when the selected amount of time is up. The user can change stations "SURF" to any station they wish, and after the selected amount of time, the TV will tune back to the original channel.

(15) MENU button and THUMB STICK

All the On-Screen display features can be set or adjusted by using these buttons.

The MENU button will start the On-Screen Display.

The THUMB STICK will highlight functions or adjust and set different features. Press the THUMB STICK toward desired direction and press down to select.

(16) EXIT button

When in MENU mode, this button will exit all On-Screen Displays.

(17) RECALL button

Press this button when no menu is displayed, when you want to check the channel being received, the picture source, or if the channel has stereo (ST) or second audio (SAP), the time, CHANNEL ID, if the Commercial Skip (C.S.) is activated, if SPECIAL EVENT REMINDER is set, and if the SLEEP timer is set.

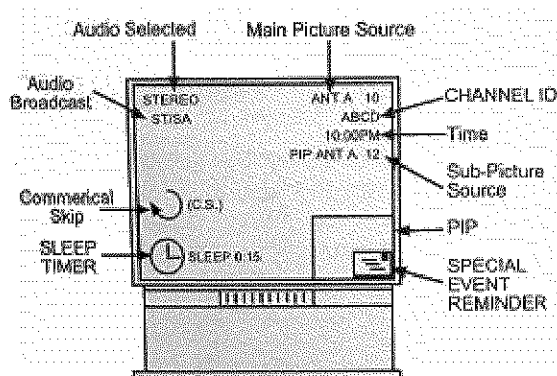

PICTURE-IN-PICTURE (PIP)

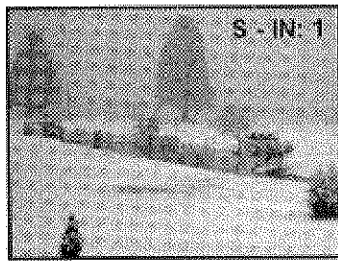

When an S-VIDEO
Input is connected to
VIDEO: 1.

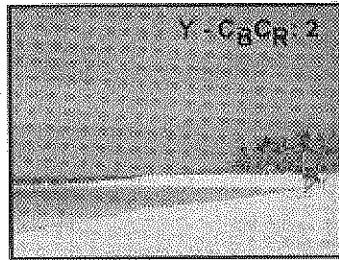

When an
COMPONENT
VIDEO: Y-CB-CR Input
is connected to
VIDEO: 2.

(18) PICTURE-IN-PICTURE buttons

See separate section on page 26 for a description.

(19) PIP CH buttons

Use the PIP CH button to select between main picture and sub-picture and sub-picture tuning. The channel number which is highlighted indicates what channel is being controlled.

(20) These buttons are not used on Remote Control CLU-574TSL.

PICTURE-IN-PICTURE (PIP)

Your HITACHI Projection TV incorporates Dual Tuner technology designed for improved viewing enjoyment. This Dual Tuner feature allows you to view antenna inputs on both the main picture and sub-picture simultaneously, with separate tuning control for each. The Dual Tuner can operate with only one input (ANT A only) or two inputs (ANT A and ANT B).

ANT A input can be viewed as both the main picture and the sub-picture simultaneously. ANT B and COMPONENT VIDEO: Y:CB-CR INPUT 2 sources can only be viewed as a main picture. To select between main picture and PIP sub-picture tuning, press the PIP CH button on the remote. The highlighted channel display will move with every press of the PIP CH button. When the top channel display is highlighted, channel tuning is for the main picture. When the lower channel display is highlighted, channel tuning is for the PIP sub-picture. This method of picture tuning is the same for one antenna input (ANT A only) and two antenna inputs (ANT A and ANT B).

The Picture-in-Picture feature is convenient when you want to watch more than one program at the same time. You can watch a TV program while viewing other programs from the ANT A source or any of the video inputs.

PICTURE-IN-PICTURE (PIP)

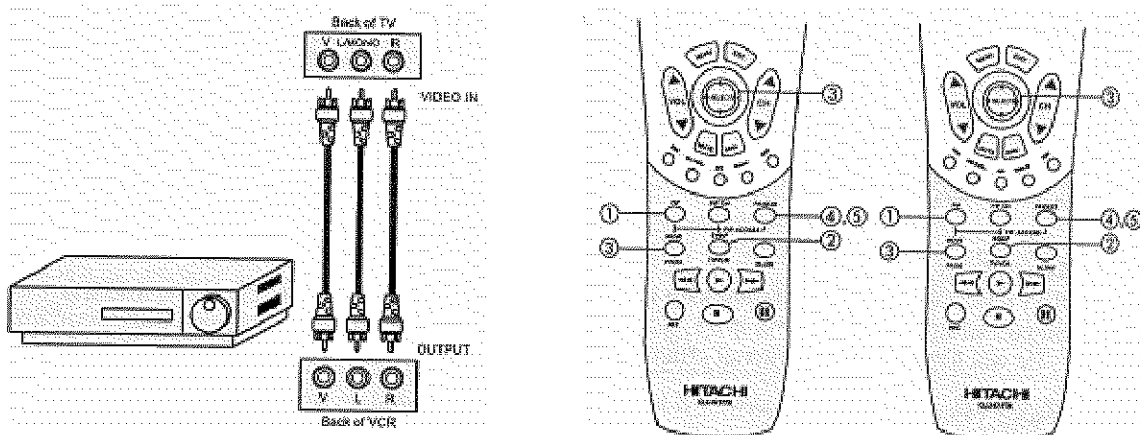

(1) PIP button

Press the PIP button and a sub-picture will appear in one of the three different modes (SINGLE, SPLIT or SURF), depending on the last selection of the PIP mode. To change the PIP mode use the THUMB STICK ▲ or ▼ and the new selection will appear the next time the PIP function is used.

SINGLE MODE PIP

Press the PIP button and a sub-picture appears in one corner of the screen. Press the button again to reduce the size of the sub-picture. Use the PIP button a third time to remove the sub-picture from the screen. Press the INPUT button when sub-picture channel tuning is controlled, to change between VIDEO: 1, VIDEO: 2, VIDEO: 3 and ANT A antenna source. (ANT B source cannot be viewed as a sub-picture and COMPONENT VIDEO: Y-CB-CR INPUT 2 source will be displayed as a blank sub-picture).

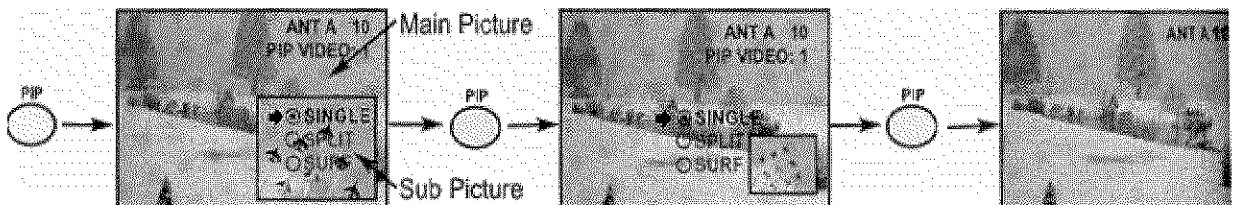

SPLIT MODE PIP

When you press the "PIP" button, the main channel and the PIP sub-picture will appear at the center of the screen (main channel on left side and sub-picture on right side). Press the "PIP" button a second time to return to normal viewing. Use the PIP CH button to select between main and sub-picture tuning control (indicated by highlighted channel display). Press the INPUT button when sub-picture channel tuning is being controlled, to change between VIDEO: 1, VIDEO: 2, VIDEO: 3, and ANT A antenna source. (ANT B source cannot be viewed as a sub-picture and COMPONENT VIDEO: Y-CB-CR INPUT 2 source will be displayed as a blank sub-picture).

PICTURE-IN-PICTURE (PIP)

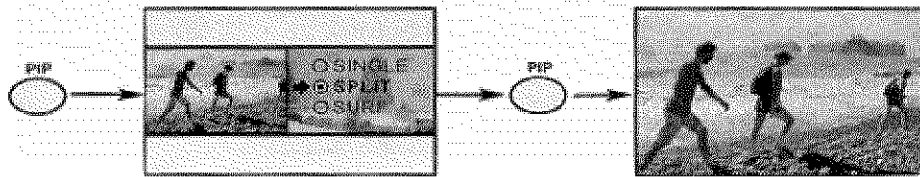

NOTES:

1. Since ANT B source cannot be viewed as a sub-picture, only SPLIT mode PIP is possible when ANT B is selected as the main channel.
2. When ANT B is selected as a main channel, the SWAP feature is disabled.
3. When the COMPONENT VIDEO: Y-CB-CR INPUT 2 is selected as PIP, it will appear as a blank sub-picture.
4. When tuned to VIDEO:2 with COMPONENT VIDEO: (Y-CB-CR) you will not be able to access the PIP functions.
5. Only sound from main picture can be heard, unless you choose sub-picture audio from the THEATER-WIRELESS SOUND mode and use the WIRELESS OUT outputs on the rear panel.

PICTURE-IN-PICTURE CONT.

SURF MODE PIP

This feature will automatically scan all active channel number (those set in memory) and display them as PIP sub-pictures, along the right edge of the screen. Press the PIP button a second time to remove the sub-pictures from the screen.

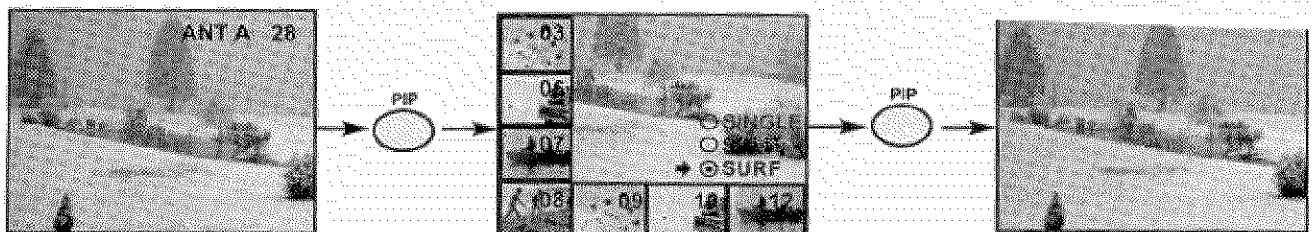

NOTES:

1. If no buttons are pressed when in SURF mode, auto-scanning will continuously scan channels in memory.
2. If a channel is tuned during this SURF scanning, sub-pictures will be removed from the screen.
3. SURF mode PIP is allowed only when ANT A is selected as the main channel.
4. If PARENTAL CONTROL MOVIE/TV RATINGS setting is ON, PIP SURF mode will be deactivated.

(2) SWAP Button

If you wish to switch what is being shown on the main picture to the sub-picture, press the SWAP button.

PICTURE-IN-PICTURE (PIP)

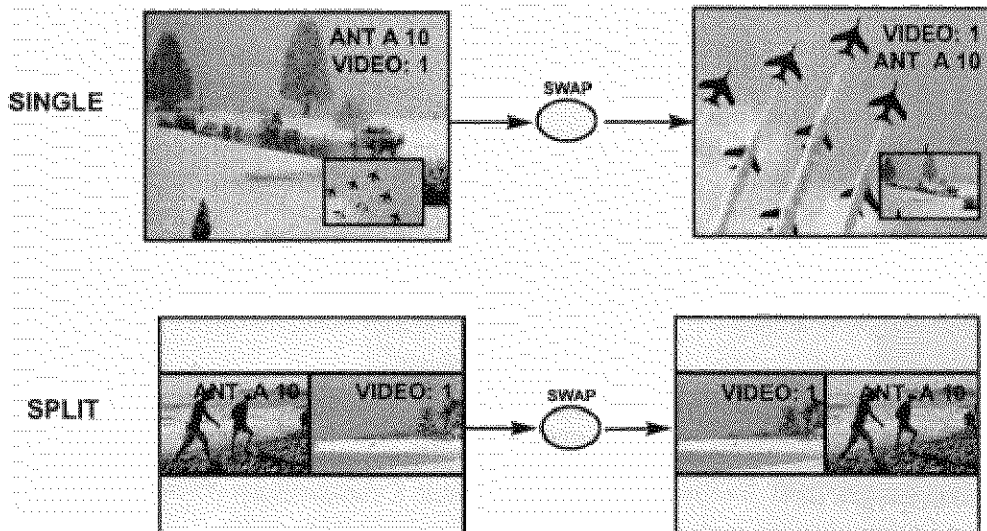

NOTES:

1. The SWAP button will only operate when SINGLE PIP mode or SPLIT PIP mode is chosen.
2. The SWAP function will not operate if ANT B input is set as the main channel (ANT B input cannot be displayed as a sub-picture).

(3) MOVE button

To move the sub-picture to another corner, press the MOVE button. The sub-picture moves one step counterclockwise every time the MOVE button is pressed. (Example below illustrates the MOVE operation for initial shipping conditions. If you have customized a PIP position, the MOVE operation may differ slightly from this example.)

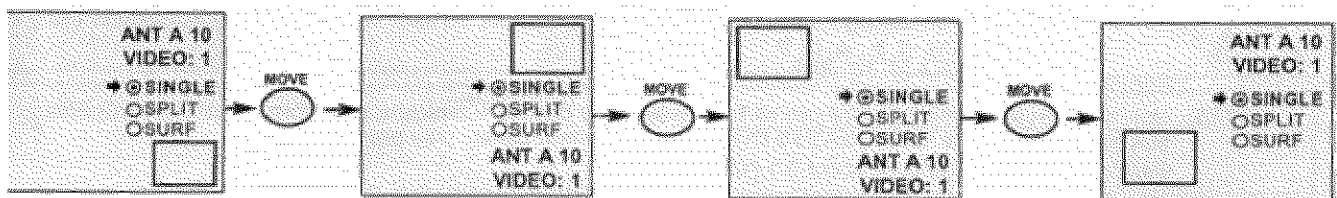

(4) FREEZE button (With PIP ON)

If you wish to freeze the sub-picture, press the FREEZE button. This is convenient when trying to write down the address for a mail order company, recording statistics for a sporting event, etc. To return the picture to motion, press the FREEZE button again.

NOTE:

The FREEZE function will only operate when SINGLE PIP or SPLIT PIP mode is chosen.

(5) FREEZE button (With PIP OFF)

Press the FREEZE button to freeze the picture depending on the mode selected (SINGLE, SPLIT or STROBE). To change FREEZE modes, use the THUMB STICK ▲ or ▼ to select which type of FREEZE mode you wish to view. The new selection will appear the next time the FREEZE function is used.

PICTURE-IN-PICTURE (PIP)

SINGLE FREEZE

Press the FREEZE button to freeze the picture you are currently viewing. Press this button again or PIP to return to normal viewing.

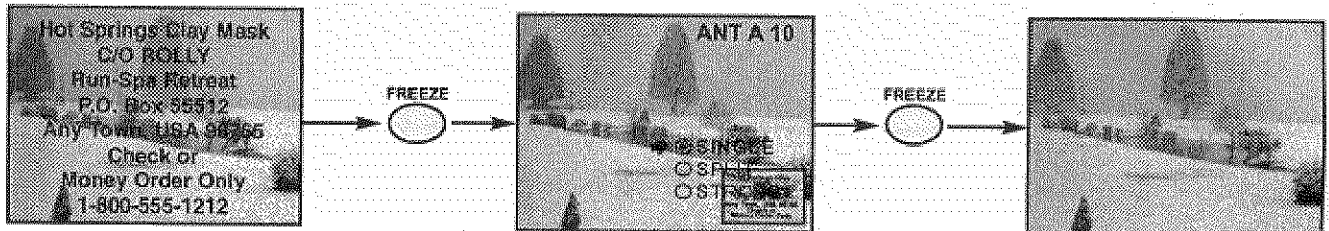

SPLIT FREEZE

Press the FREEZE button to freeze the picture you are currently viewing. (Only the left sub-picture will freeze). Press this button again or PIP to return to normal viewing.

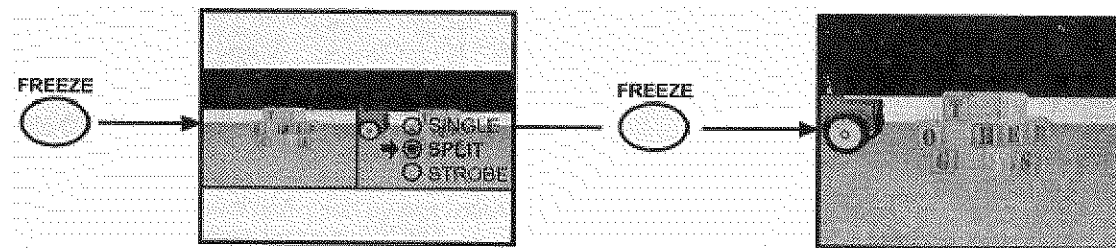

STROBE FREEZE

Press the FREEZE button to freeze three frames of the picture you are currently viewing. Press this button again or PIP to return to normal viewing. This feature is useful for viewing a moving picture that has many details, for example, a close play in a sporting event or a golf swing.

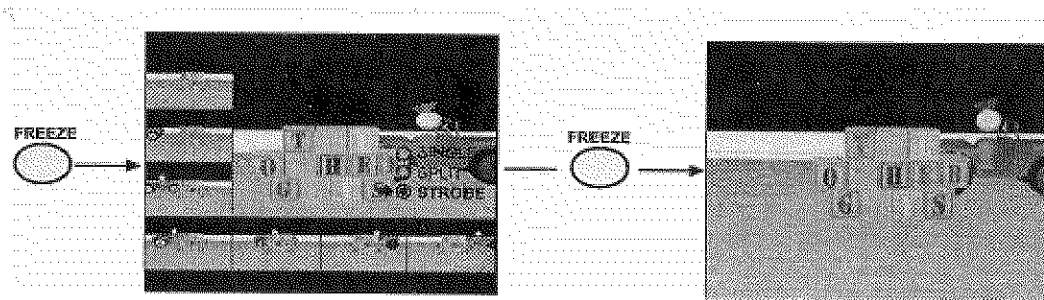

CAUTION: A pattern burn may develop if the sub-picture is left in the same corner permanently. If the PIP feature is used frequently, occasionally MOVE the sub-picture to a different corner. You may also vary its position using the THUMB STICK ◀, ▶, ▲, or ▼.

NOTES:

Only sound from the main picture can be heard, unless you choose sub-picture audio from the

PICTURE-IN-PICTURE (PIP)

THEATER-WIRELESS SOUND mode and use the WIRELESS OUT outputs on the rear panel.
(see page 62)

Each freeze frame is delayed about 0.1 (1/10) second.

The FREEZE function will display blank sub-pictures when the COMPONENT VIDEO: Y-CB-CR INPUT 2 source is set as main channel.

USING THE REMOTE TO CONTROL VCR FUNCTIONS

USING THE REMOTE TO CONTROL VCR FUNCTIONS

Operating the precoded function for your VCR.

This remote is designed to operate different types of VCRs. You must first program the remote to match the remote system of your VCR. (refer to page 34 for pre-codes)

1. Turn ON your VCR.
2. Aim the remote control at the front of your VCR.
3. Press and release the VCR button to switch to the VCR pre-coded mode.
4. Hold down the VCR button on the remote, enter the two digit preset code that matches your VCR, as shown on page 34. The indicator light will flash 3 times if the code was accepted.
5. Aim the remote at the VCR and press the POWER button. The remote will turn off your VCR when the correct two digit preset code is entered. When this occurs, the remote control is programmed for your VCR. If the VCR does not turn off, try a different two digit preset code.
6. The remote will now control your VCR.

NOTES:

1. If your VCR cannot be operated after performing the above procedures, your VCR's code has not been precoded into the remote.
2. In the unlikely event that your VCR cannot be operated after performing the above procedures, please consult your VCR operating guide.
3. The remote control will remember the codes you have programmed until the batteries are removed from the remote control. After replacing the batteries repeat the entire programming procedure as stated above.
4. The LAST CH button will act as your VCR ENTER button if required.
5. The SLEEP button will act as your VCR '100' button if required.

[Click here for remote CLU-573TSL.](#)

[Click here for remote CLU-574TSL.](#)

(1) VCR Button

This button allows the remote to control your VCR by setting it to VCR mode.

(2) PRECODED VCR Buttons

These buttons transmit the chosen precoded VCR codes. For some VCRs, you must press the RECORD button twice to record a program.

(3) EXCLUSIVE TV Buttons

These buttons are for operating the TV.

MY VCR CODE IS: _____

USING THE REMOTE TO CONTROL VCR FUNCTIONS

NOTE: Refer to instruction manual of the VCR for operation of the buttons exclusively for the VCR.

USING THE REMOTE TO CONTROL CABLE BOX FUNCTIONS

USING THE REMOTE TO CONTROL CABLE BOX FUNCTIONS

Operating the pre-coded function for your cable box.

This remote is designed to operate different types of cable boxes. You must first program the remote to match the remote system of your cable box. (Refer to page 34.)

1. Turn ON your cable box.
2. Aim the remote control at the front of your cable box.
3. Press the CBL button to switch to Cable pre-coded mode.
4. Hold down the CBL button on the remote and enter the two digit preset code that matched your Cable box as shown on page 34. The indicator light will flash 3 times if the code was accepted.
5. Aim the remote at the cable box and press the POWER button. The remote will turn off your Cable box when the correct two digit preset code is entered. When this occurs, the remote control is programmed for your Cable box. If the Cable box does not turn off, try a different two digit preset code.
6. The remote will now control your Cable box.

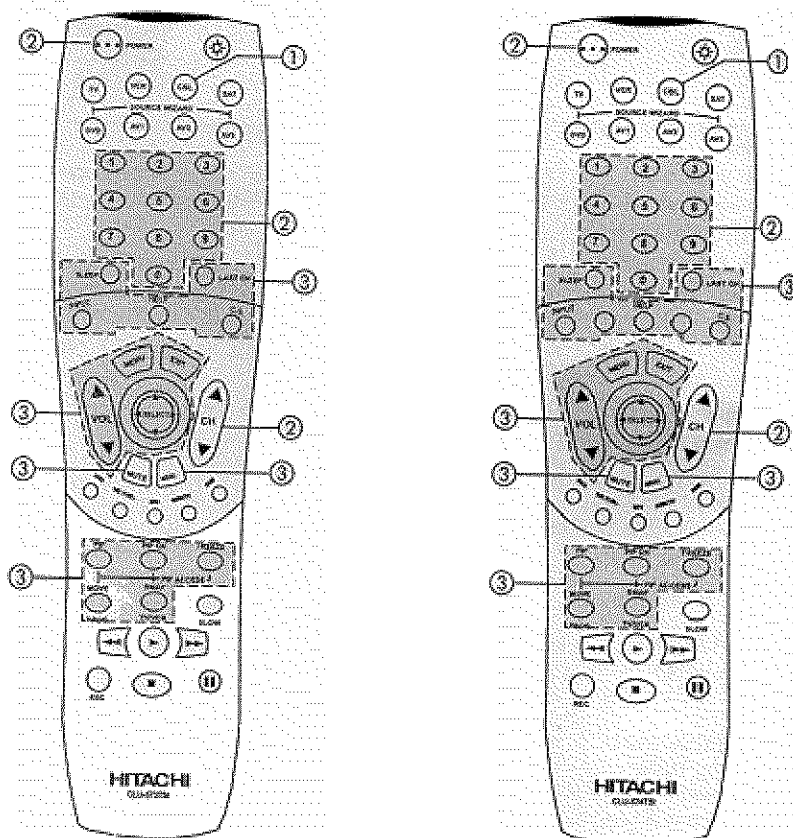

USING THE REMOTE TO CONTROL SATELLITE RECEIVER FUNCTIONS

NOTES:

1. If your cable box cannot be operated after performing the above procedures, your cable box code has not been precoded into the remote.
2. In the unlikely event that your cable box cannot be operated after performing the above procedures, please consult your cable box operating guide.
3. The remote control will remember the codes you have programmed until the batteries are removed from the remote control. After replacing the batteries repeat the entire programming procedure stated above.
4. The LAST CH button will act as your cable box ENTER button if required.
5. The SLEEP button will act as your audio components '100' button if required.

(1) CABLE (CBL) Button

This button allows the remote to control your cable box by setting it to CABLE mode.

(2) PRECODED CABLE Box buttons

These buttons transmit the chosen precoded cable codes.

(3) EXCLUSIVE TV buttons

These buttons are for operating the TV.

MY CABLE BOX CODE IS: _____

NOTE: Refer to instruction manual of the Cable Box for operation of the buttons exclusively for the Cable Box.

USING THE REMOTE TO CONTROL SATELLITE RECEIVER FUNCTIONS

Operating the precoded function for your satellite receiver.

This remote is designed to operate different types of satellite systems. You must first program the remote to match the remote system of your satellite receiver. (refer to page 34.)

1. Turn ON your satellite receiver.
2. Aim the remote control at the front of your satellite receiver.
3. Press and release the SATELLITE (SAT) button on the remote to switch to satellite precoded mode.
4. Hold down the SAT button on the remote and enter the two digit preset code that matches your satellite receiver as shown on page 34. The indicator light will flash 3 times if the code was accepted.
5. Aim the remote at the Satellite receiver and press the POWER button. The remote will turn off your Satellite receiver when the correct two digit preset code is entered. When this occurs,

USING THE REMOTE TO CONTROL SATELLITE RECEIVER FUNCTIONS

the remote control is programmed for your Satellite receiver. If the Satellite receiver does not turn off, try a different two digit preset code.

6. The remote will now control your Satellite receiver.

NOTES:

1. If your satellite receiver cannot be operated after performing the above procedures, your satellite receiver code has not been precoded into the remote.
2. In the unlikely event that your satellite receiver cannot be operated after performing the above procedures, please consult your satellite receiver operating guide.
3. The remote control will remember the codes you have programmed until the batteries are removed from the remote control. After replacing the batteries repeat the entire programming procedure stated above.
4. The INPUT button will act at the TV/SAT button when in SAT mode.

(1) SATELLITE (SAT) button

This button allows the remote to control your satellite receiver by setting it to SATELLITE mode.

(2) PRECODED SATELLITE RECEIVER buttons

These buttons transmit the chosen precoded cable codes.

(3) EXCLUSIVE TV buttons

These buttons are for operating the TV.

MY SATELLITE RECEIVER CODE IS: _____

NOTE: Refer to instruction manual of the Satellite Receiver for operation of the buttons exclusively for the Satellite Receiver.

USING THE REMOTE TO CONTROL DVD FUNCTIONS

USING THE REMOTE TO CONTROL DVD FUNCTIONS

Operating the precoded function for your DVD player.

This remote is designed to operate different types of DVD players. You must first program the remote to match the remote system of your DVD player. (refer to page 34 for precodes)

1. Turn ON your DVD player.
2. Aim the remote control at the front of your DVD player.
3. Press and release the DVD button to switch to DVD pre-coded mode.
4. Hold down the DVD button on the remote and enter the two digit preset code that matches your DVD player, as shown on page 34. The indicator light will flash 3 times if the code was accepted.
5. Aim the remote at the DVD player and press the POWER button. The remote will turn off your DVD player when the correct two digit preset code is entered. When this occurs, the remote control is programmed for your DVD player. If the DVD player does not turn off, try a different two digit preset code.
6. The remote will now control your DVD player.

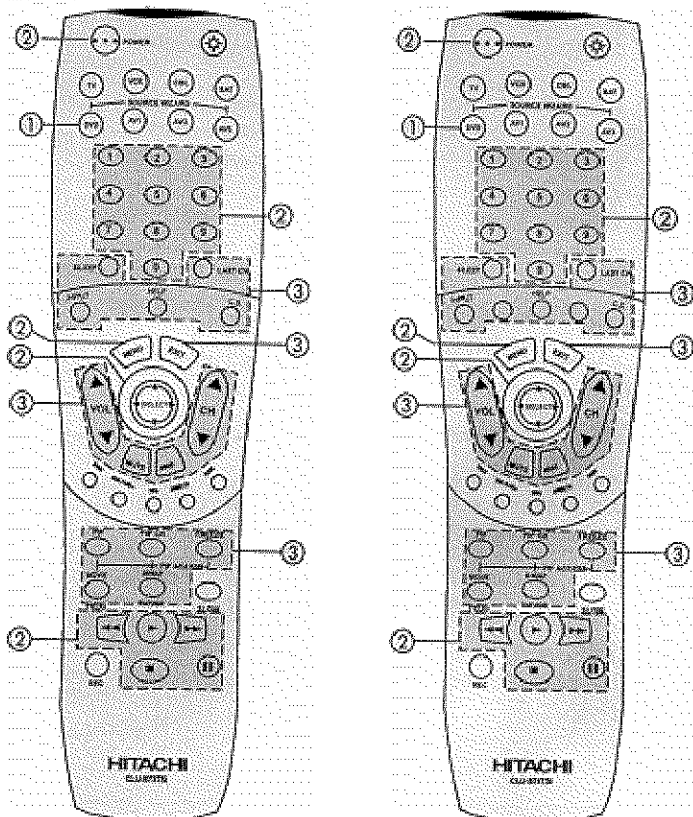

USING THE REMOTE TO CONTROL ADDITIONAL AUDIO/VIDEO EQUIPMENT

NOTES:

1. If your DVD player cannot be operated after performing the above procedures, your DVD player code has not been precoded into the remote.
2. In the unlikely event that your DVD player cannot be operated after performing the above procedures, please consult your DVD player operating guide.
3. The remote control will remember the codes you have programmed until the batteries are removed from the remote control. After replacing the batteries repeat the entire programming procedure stated above.

(1) DVD Button

This button allows the remote to control your DVD player by setting it to DVD mode.

(2) PRECODED DVD Buttons

These buttons transmit the chosen precoded DVD codes.

(3) EXCLUSIVE TV Buttons

These buttons are for operating the TV.

MY DVD PLAYER CODE IS: _____

NOTE: Refer to instruction manual of the DVD player for operation of the buttons exclusively for the DVD player.

USING THE REMOTE TO CONTROL ADDITIONAL AUDIO/VIDEO EQUIPMENT

Operating the precoded function for your Audio/Video component.

This remote is designed to operate different types of AUDIO/VIDEO EQUIPMENT. You must first program the remote to match the remote system of your AUDIO/VIDEO EQUIPMENT. (refer to page 37.)

1. Turn ON your AUDIO/VIDEO EQUIPMENT.
2. Aim the remote control at the front of your AUDIO/VIDEO EQUIPMENT.
3. Press and release the AV1, AV2 or AV3 button to switch to AUDIO/VIDEO EQUIPMENT pre-coded mode.
4. Hold down the AV1, AV2 or AV3 button on the remote and enter the two digit preset code that matches your AUDIO/VIDEO EQUIPMENT, as shown on page 34. The indicator light will flash 3 times if the code was accepted.

USING THE REMOTE TO CONTROL ADDITIONAL AUDIO/VIDEO EQUIPMENT

5. Aim the remote at the Audio/Video component and press the POWER button. The remote will turn off your AUDIO/VIDEO EQUIPMENT when the correct two digit preset code is entered. When this occurs, the remote control is programmed for your AUDIO/VIDEO EQUIPMENT. If the AUDIO/VIDEO EQUIPMENT does not turn off, try a different two digit preset code.

6. The remote will now control your AUDIO/VIDEO EQUIPMENT.

7. Repeat steps 1 - 6 if you wish to program the remote to control another audio/video component. Be sure to use a different A/V button on the remote, since only one component can be programmed per button.

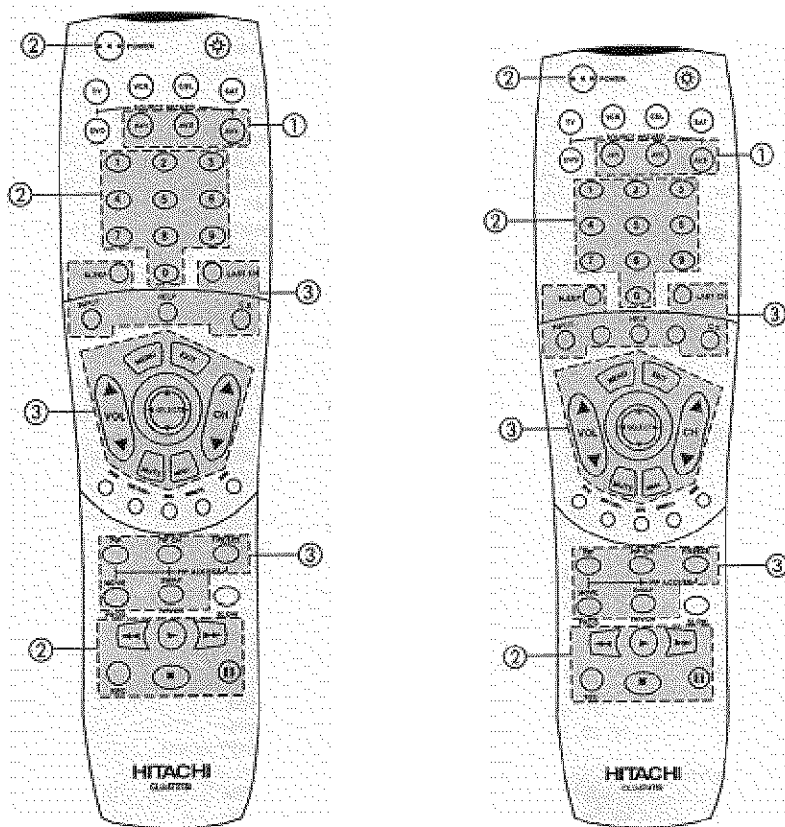

NOTES:

1. If your Audio/Video component cannot be operated after performing the above procedures, your Audio/Video component code has not been precoded into the remote.
2. In the unlikely event that your Audio/Video component cannot be operated after performing the above procedures, please consult your Audio/Video equipment operating guide.
3. The remote control will remember the codes you have programmed until the batteries are removed from the remote control. After replacing the batteries repeat the entire programming procedure stated above.

CABLE/SATELLITE, VCR, AUDIO AND DVD CODES (CLU-573TSI and CLU-574TSI)

(1) AV1, AV2, AV3 Button

These buttons allows the remote to control your audio/video equipment by setting it to audio/video mode.

(2) PRECODED AUDIO/VIDEO Buttons

These buttons transmit the chosen precoded audio/video component codes.

(3) EXCLUSIVE TV Buttons

These buttons are for operating the TV.

MY AUDIO/VIDEO EQUIPMENT CODE IS: AV1 _____
 AV2 _____
 AV3 _____

NOTE: Refer to instruction manual of the Audio/Video equipment for operation of the buttons exclusively for the Audio/Video equipment.

CABLE/SATELLITE, VCR, AUDIO AND DVD CODES (CLU-573TSI and CLU-574TSI)

VCR BRANDS

Adventura	01	Aiko	09
Aiwa	01	Akai	02,47,48
American High	23	Asha	44
Audiovox	24	Beaumark	44
Bell & Howell	32	Brandt	42
Broksonic	33,34,41,49,50	Calix	24
Canon	23	Capehart	07
Carver	31	CCE	09,30
Citizen	09,24	Colt	30
Craig	19,24,30,44	Curtis Mathes	02,23,46
Cybernex	44	Daewoo	07,09,17,37
Daytron	07	Dynatech	01
Electrohome	24	Electroponic	24
Emerex	08	Emerson	01,09,13,16,24,27,28, 33,36,41,47,49,50
GE	04,23,40,46	Gerrard	01
Goldstar	24,25,43	Gradiente	01
Harley Davidson	01	Harmon/Kardon	25
Harwood	30	Headquarter	18
Hi-Q	19	Hitachi	02,03,04,05

CABLE/SATELLITE, VCR, AUDIO AND DVD CODES (CLU-573TSI and CLU-574TSI)

Jensen	02	JVC	02,14,26
KEC	09,24	Kenwood	02,25,26
KLH	30	Kodak	23,24
Lloyd	01	Lloyd's	27
Logik	30	LXI	24
Magnavox	15,23,29,31,35	Magnin	44

CABLE/SATELLITE, VCR, AUDIO AND DVD CODES (CLU-573TSI and CLU-574TSI)

Marantz	23,31	Marta	24
Matsushita	23	MEI	23
Memorex	01,15,18,19,20,23,24,32,44	MGA	16,47
MGN Technology	44	Minolta	03,05
Mitsubishi	16,26,39,47,48	Motorola	20,23
MTC	01,44	Multitech	01,30
NEC	02,06,25,26,32	Nikko	24
Noblex	44	Olympus	12,23
Optimus	20,24,32	Orion	49
Panasonic	11,12,23,38,51	Penney	03,06,23,24,25,44,45
Pentax	03,04,05	Philco	23
Phillips	23,29,31	Pilot	24
Pioneer	26	Portland	07
Protec	30	Pulsar	15
Quarter	18	Quartz	18
Quasar	23	Radio Shack	01,24
Radix	24	Randex	24
RCA	03,04,05,35,40,46	Realistic	01,18,19,20,21,23,24,32,44
Ricoh	22	Runco	15
Samsung	17,44	Sanky	15,20
Sansui	02,26	Sanyo	18,19,32,44
Scott	16,17,33,34,36,41	Sears	03,05,18,21,23,24,32,45
Sharp	20	Shintom	30
Shogun	44	Singer	30
Sony	08,10,22,23	STS	03
Sylvania	01,16,23,29,31	Symphonic	01
Tatung	02	Teac	01,02
Technics	23,38	Teknika	01,23,24
Telefunken	42	TMK	27,44
Toshiba	16,17,21,36	Totevision	24,44
Unitech	44	Vector	17
Vector Research	06,25	Video Concepts	06,17,47
Videosonic	44	Wards	01,03,19,20,23,30,35,36,44,46
XR-1000	01,23,30	Yamaha	25
Zenith	10,15,22		

CABLE/SATELLITE, VCR, AUDIO AND DVD CODES (CLU-573TSI and CLU-574TSI)

DVD BRAND

Denon	04	Hitachi	07
JVC	01	Kenwood	04
Magnavox	05	Mitsubishi	10
Panasonic	04	Philips	06
Pioneer	03	RCA (Proscan)	09
Sony	02	Toshiba	05
Yamaha	08	Zenith	05

CABLE BRAND

ABC	01,07,08,17,18,20,36,37,49	Antronix	39
Archer	11,24,39	Belcor	32
Cable Star	32	Century	11
Citizen	11	Colour Voice	30,42
Comtronics	25,28	Contec	21
Dae Ryung	20	Eastern	14
Electricord	31	Everquest	51
Focus	52	GC Electronics	32,39
Gemini	05,38,43,51	General Instrument	01,12
Goldstar	10,25	Hamlin	04,13,22,23
Hitachi	01	Hytex	36
Jasco	11	Jerrold	01,08,12,37,49,50,51
Macom	35	Magnavox	15
Memorex	03	Movie Time	29,31,33
NSC	29,33,38	Oak	21,36,46
Panasonic	02,03,09	Phillips	11,15,16,26,30,42,43,44
Pioneer	06,10,19	Popular Mechanics	52
Pulsar	03	RCA	02
Realistic	39	Recoton	52
Regal	04,22,34	Regency	14
Rembrandt	01,38	Runco	03
Samsung	10,25	Scientific Atlanta	17,20,41,45
Signal	25,51	Signature	01
SL Marx	25	Sprucer	02

CABLE/SATELLITE, VCR, AUDIO AND DVD CODES (CLU-573TSI and CLU-574TSI)

Starcom	37,49,51	Stargate	25,51
Starquest	51	Starsight	53,54
Sylvania	18	Teleview	25
Texscan	18	Tocom	07,27,50
Toshiba	03	Tusa	51
TV 86	29	Unika	11m39
United Artists	36	United Cable	49
Universal	11,24,31,32,34,39	Videoway	47
Viewstar	15,28,29,40	Zenith	03,48
Zentek	52		

SATELLITE BRAND CODES

Echostar	04	Hitachi	01
Hughes	05	RCA	02
Sony	03		

AMPLIFIER BRAND

Aiwa	05,06	Carver	01,06,07,08
Casio	09	Clarinette	09
Denon	10	Fisher	08,11
Hitachi	12	JVC	13
Kenwood	14,15,17,18	Lloyd's	09
Magnavox	01,06,09	Marantz	01,06,16
MCS	16	Modulaire	06
Onkyo	09	Optimus	16
Panasonic	01,06	Philips	03,04,20,21,22
Pioneer	16	Quasar	09
Realistic	06	Sansui	11
Sanyo	15	Sharp	05
Sony	02,16,23,24,25	Technics	13
Victor	03,04,05,07,20,21	Wards	15,26
Yamaha	09	Yorx	03,04,11,15,20

CABLE/SATELLITE, VCR, AUDIO AND DVD CODES (CLU-573TSI and CLU-574TSI)

CD BRAND

Adcom	02	Aiwa	02
California Audio Lab	03	Carver	02
Denon	04	DKK	05
Emerson	01	Fisher	06
Genexxa	07	Hitachi	01,07,08,09,10,11,12
JVC	13	Kenwood	06,14,15
Krell	02	Magnavox	02
Marantz	02,03	MCS	03
Mission	03	NSM	02
Onkyo	16	Optimus	05,07,17
Panasonic	03	Philips	02
Pioneer	07,17	Proton	02
QED	02	Quasar	03
RCA	01,21	Realistic	01
Rotel	02	SAE	02
Sansui	02	Scott	01
Sony	05,18	Technics	03,19,20
Victor	13		

TAPE BRAND

Aiwa	11,12	Hitachi	01,02,03,04
Jerrold	13,14	JVC	05
Kenwood	06	Optimus	07
Panasonic	08	Pioneer	07
Scientific Atlanta	15	Sony	09,10,11,12
Starcom	13	Wards	07

ULTRATEC OSD

ULTRATEC OSD

1. Press MENU on the remote control to display the different features on your HITACHI Projection TV.
2. Press the THUMB STICK to highlight a different feature.
3. Press EXIT on the remote control to quickly exit from a menu.
4. Press HELP on the remote control when a menu is displayed, and text will appear giving a description of that menu.

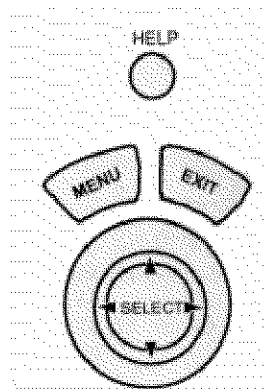

This part of the screen shows what selections are available.

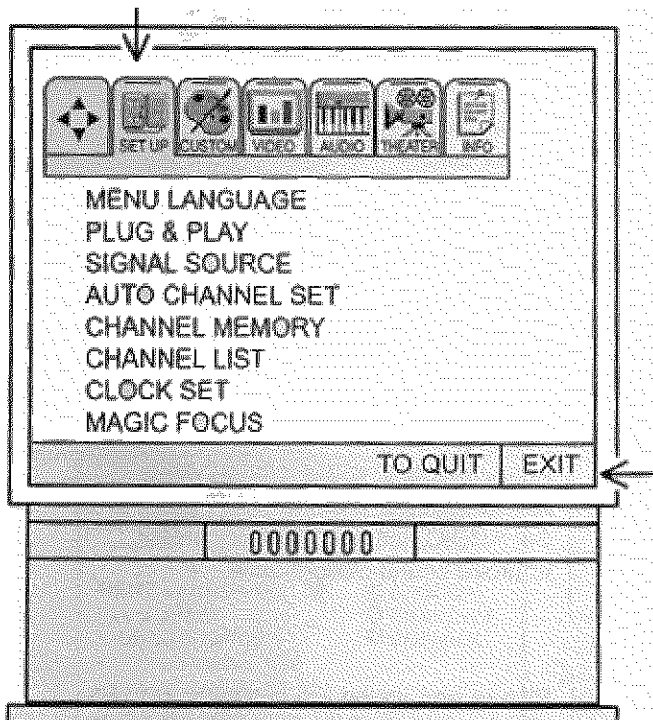

This part of the screen shows which remote control buttons to use.



MENU LANGUAGE
PLUG & PLAY
SIGNAL SOURCE
AUTO CHANNEL SET
CHANNEL MEMORY
CHANNEL LIST
CLOCK SET
MAGIC FOCUS
white.

Choose English, French, or Spanish text.
Optimum hook up for your system.
Select Antenna or Cable TV.
First time set up for channel buttons.
Channel buttons, add, skip.
Check channel name, scan, and child lock.
Set before using timer features.
Automatically match red, green, and blue colors to make white.



CHANNEL ID
VIDEO ID
FAMILY FAVORITES
PARENTAL CONTROL
4 EVENT PROGRAM
AUTO LINK
CLOSED CAPTION
MENU BACKGROUND
FIRST TIME TOUR

Label channels PAY 1, ABC, etc.
Label video inputs VCR1, DVD1, etc.
Allows you to set and view favorite channels.
Block channel picture and sound.
Turn TV on and off once, daily, or weekly.
Automatically turn TV on with any VIDEO input.
Feature to display dialogue/text.
Select from three types of backgrounds.
Introduces you to basic TV functions.



CONTRAST
BRIGHTNESS
COLOR
TINT
SHARPNESS
RESET
ADVANCED SETTINGS

Adjust contrast.
Adjust brightness.
Adjust color.
Adjust tint.
Adjust sharpness.
Set VIDEO settings to factory preset.
Improve picture performance.

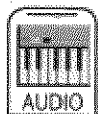

BASS
TREBLE
BALANCE

Adjust bass.
Adjust treble
Adjust balance.

ULTRATEC OSD

RESET
ADVANCE SETTINGS

Set AUDIO settings to factory preset.
Improve sound performance.



THEATER MODES
SURROUND
GRAPHIC EQ.
WIRELESS SOUND
SUP WOOFER

Picture and sound are automatically set.
Special sound effects, including Dolby Pro Logic.
More precise audio control.
Select from three types of audio for wireless output.
Adjust Sub-Woofer volume.



SPECIAL EVENT REMINDER
CALENDAR

Set TV to remind you of birthdays, etc..
Check day, month, year, and special events.

SET UP

SET UP

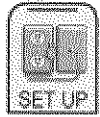

Select INITIAL SETUP when setting your TV up for the first time. Use the THUMB STICK ▲ or ▼ on the remote to highlight the function desired.

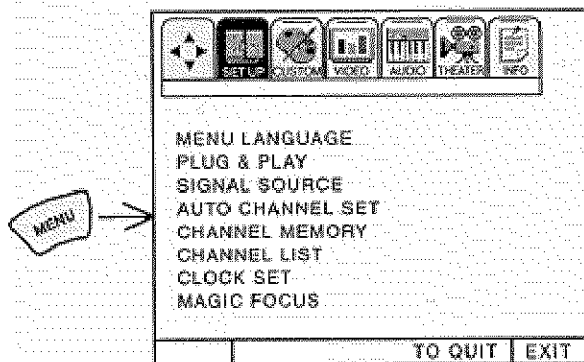

NOTE:

To see an auto-demonstration of the on-screen displays with HELP text displayed, press and hold the POWER button on the TV set for approximately five seconds. Press the POWER button on the TV again to end the auto-demonstration.

MENU LANGUAGE

This feature will allow you to select any one of three different languages for all on-screen displays.

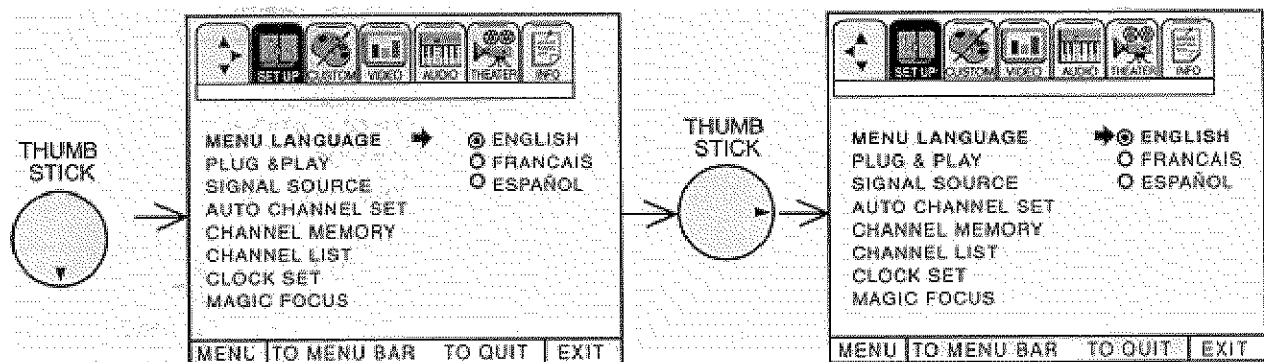

Use THUMB STICK ▲ or ▼ to select the MENU LANGUAGE of your choice.

Press EXIT to quit menu or THUMB STICK ◀ to return to previous menu.

SET UP

PLUG & PLAY

This graphic guide function will help you to properly set up your TV or Home Theater System. Simply answer three questions and a graphic will be displayed, showing you the optimum setup for your personalized system.

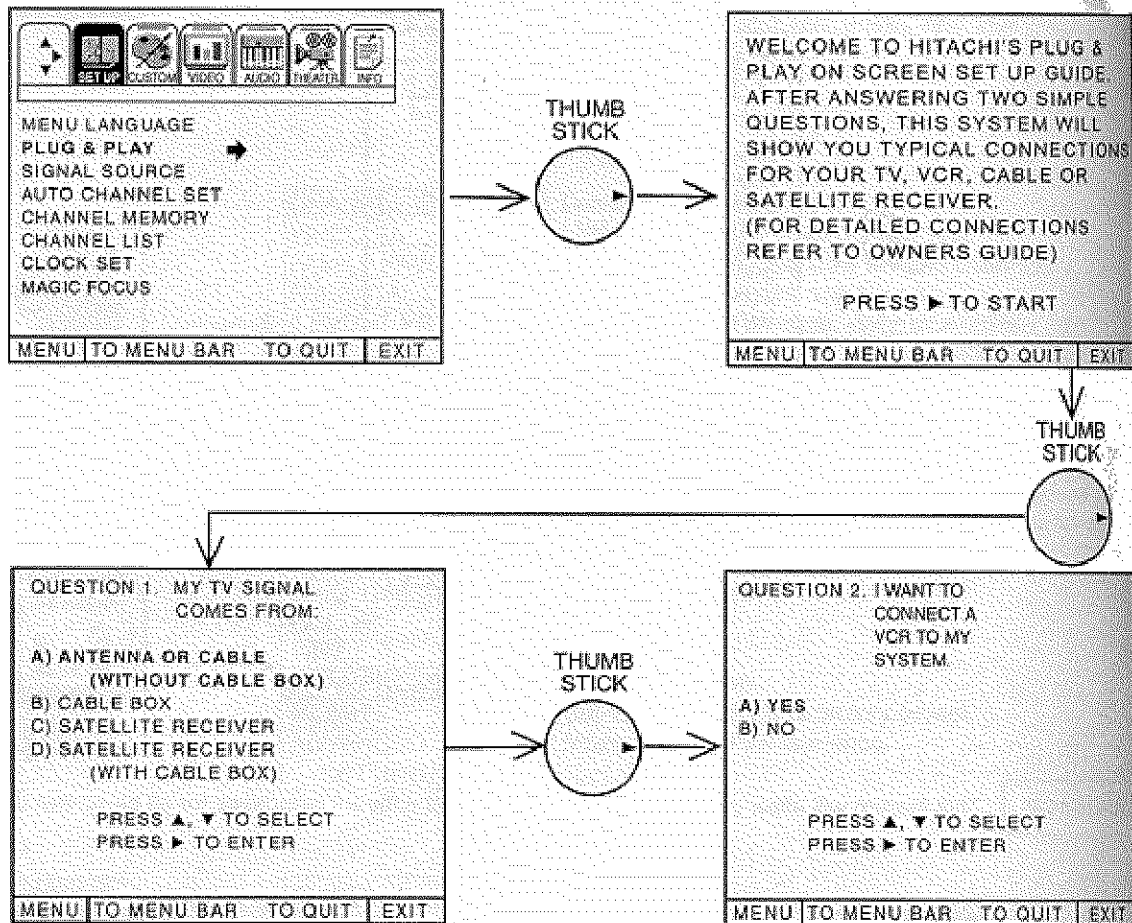

Press THUMB STICK ▲ or ▼ to highlight the correct answers to all three questions.

Press THUMB STICK ► to display the graphic guide.

Press EXIT to quit menu or THUMB STICK ► to begin AUTO CHANNEL SET. (See page 40).

SET UP

SIGNAL SOURCE

Select ANTENNA if you are using an indoor or outdoor antenna. Select CATV if you have cable TV.

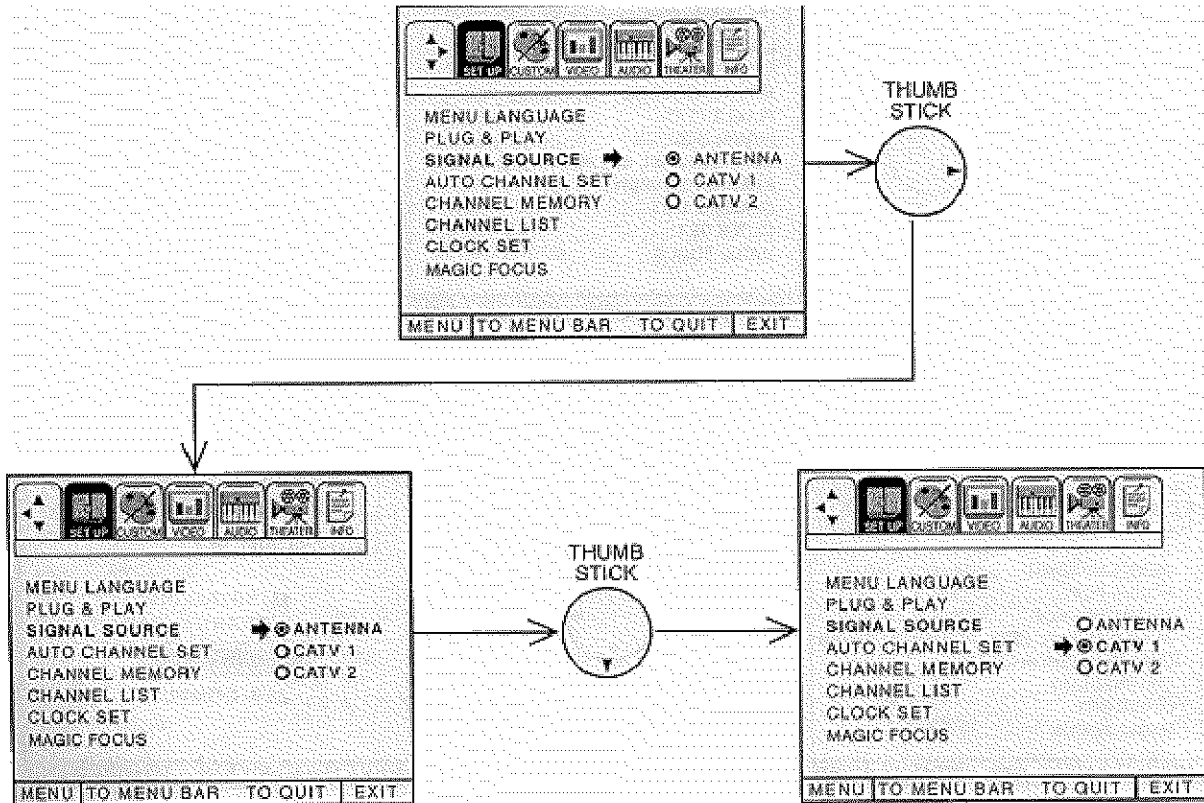

Press THUMB STICK ▲ or ▼ to highlight and select the correct SIGNAL SOURCE mode. Press EXIT to quit MENU or THUMB STICK ◀ to return to previous menu.

RECEPTION BAND

RECEPTION BAND		
AIR	CATV 1 or CATV 2	
	CATV CHANNEL	Indicated on the screen
VHF 2 - 13ch UHF 14 - 69ch	VHF 2 - 13	2 - 13
	Mid band A - I	14 - 22
	A-5 - A-1	95 - 99
	Super band J - W	23 - 36
	Hyper band W + 1 - W + 28	37 - 64
	Ultra band W + 29 - W + 84	65 - 125

Reception channels for each mode are shown at the left.

Refer to your cable or TV guide for channel identification standards.

If certain CATV channels are poor or not possible in CATV1 mode, set SIGNAL SOURCE to CATV2.

SET UP

AUTO CHANNEL SET

This feature will automatically store active TV channels in CHANNEL MEMORY. This will allow you to skip unused channels when using the CHANNEL UP (▲) or DOWN (▼).

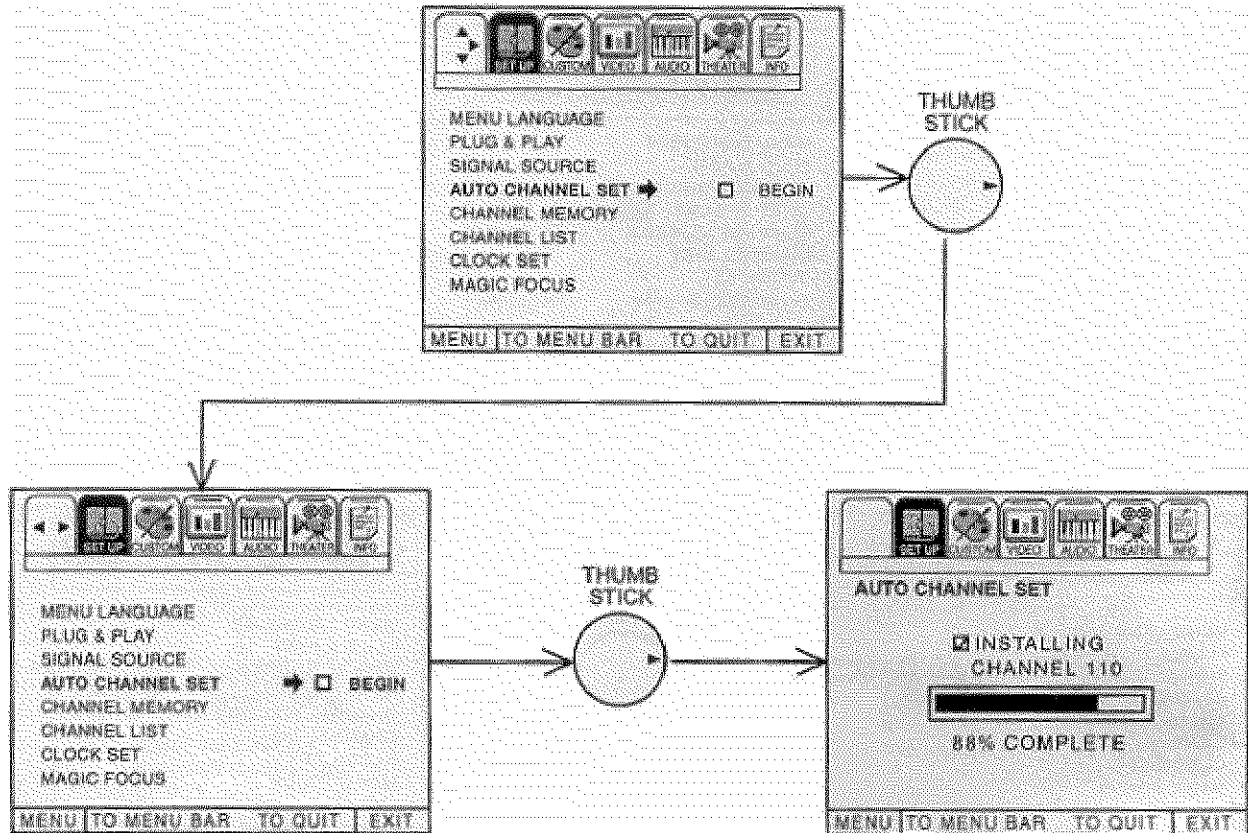

If the EXIT button is pressed while the AUTO CHANNEL SET function is engaged, programming will stop.

Remember to select the correct SIGNAL SOURCE mode before using AUTO CHANNEL SET. See CHANNEL MEMORY to add or to erase additional channels.

CHANNEL MEMORY

Use this function after AUTO CHANNEL SET to add or erase additional channels to the remote control CHANNEL ▲ or ▼ buttons.

SET UP

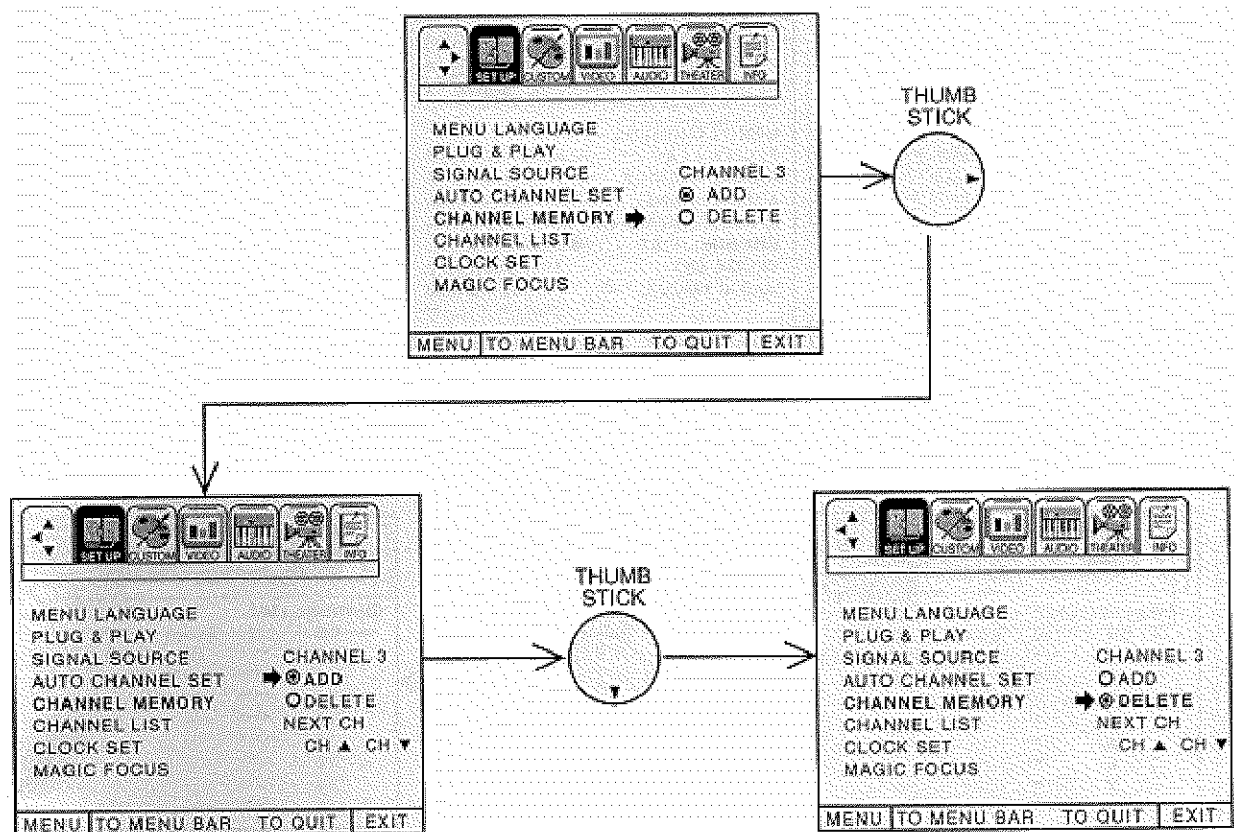

Add or erase additional channels while still in CHANNEL MEMORY using CHANNEL ▲ or ▼ or the number buttons to change the channel.

Press EXIT to quit menu or THUMB STICK ◀ to return to previous menu.

SET UP

CHANNEL LIST

This function allows you to review which channels are labeled in CHANNEL ID (ID), which have been added to CHANNEL MEMORY (SCAN), and which are protected by PARENTAL CONTROL (LOCK).

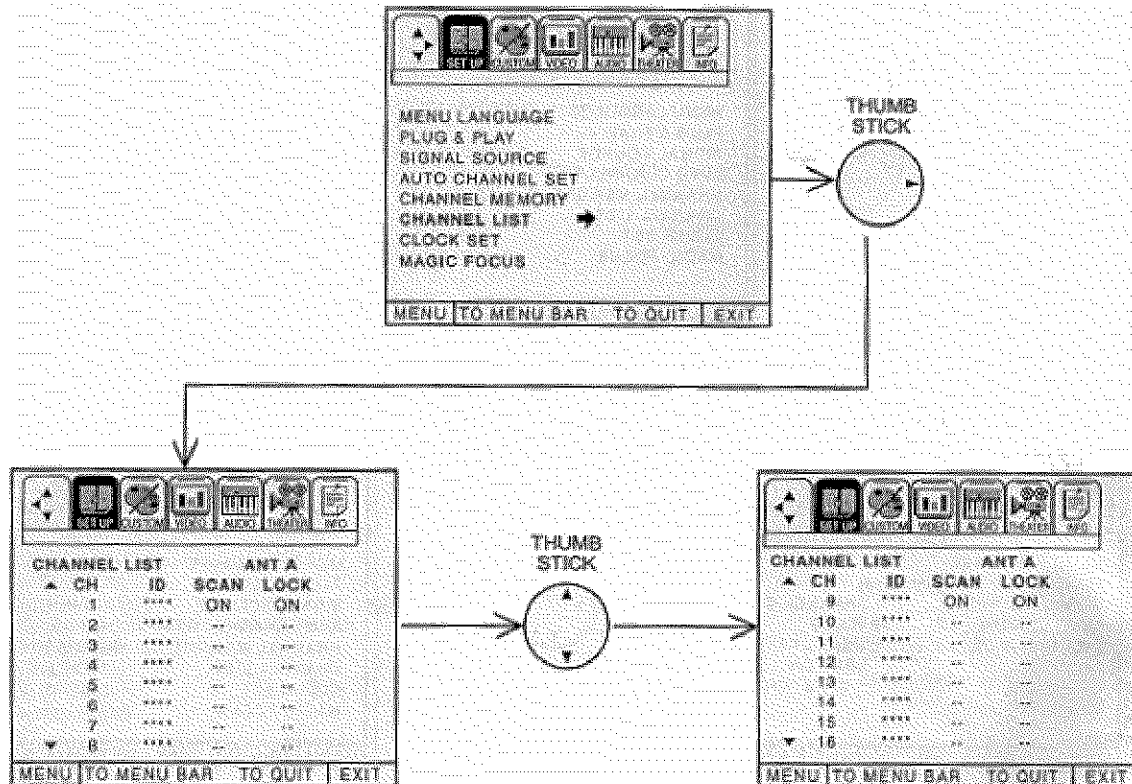

Press THUMB STICK ▲ or ▼ to review more channels.

Press EXIT to quit menu or THUMB STICK ◀ to return to previous menu.

NOTE: Each touch of THUMB STICK ▲ or ▼ will display the next eight channels.

CLOCK SET

The time must be set before you can use the CALENDAR, 4 EVENT PROGRAM, SPECIAL EVENT REMINDER or TV TIME OUT.

SET UP

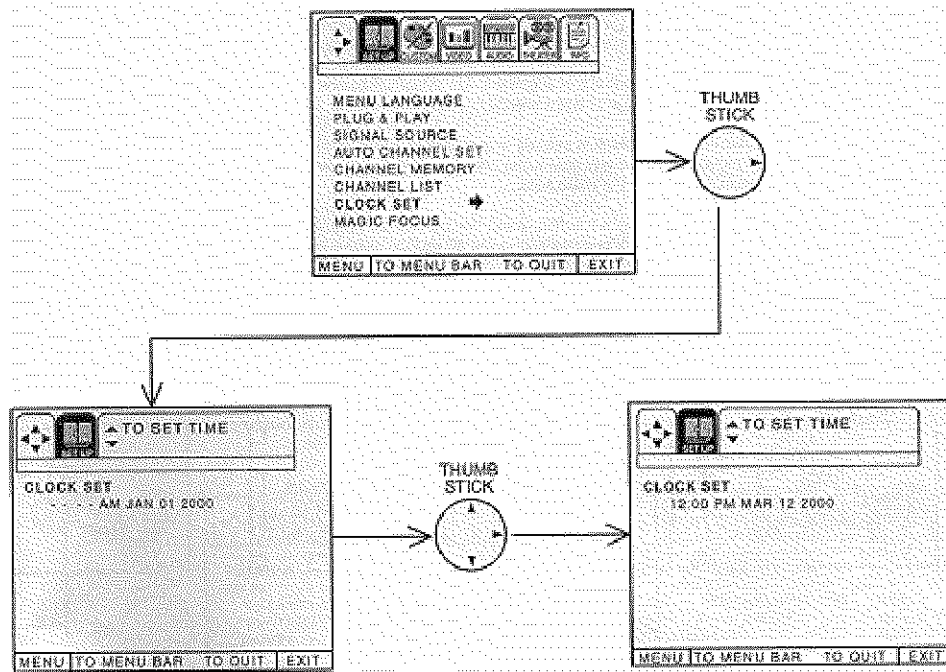

Use THUMB STICK ▲ or ▼ to set the time, date, and year.

Press THUMB STICK ◀ or ▶ to change position.

Press EXIT to quit menu or THUMB STICK ◀ to return to previous menu when the CURSOR is in the first position.

SET UP

MAGIC FOCUS

Your HITACHI Projection TV has three color projection tubes: one for red, one for green, one for blue. When mixed together in the proper proportion, the output of these three color tubes can produce any color. To produce these colors, however, the beams must be precisely aligned over each other so that the colors can be mixed. The process of aligning these picture beams is called "convergence".

Over a period of time, the picture tubes can drift out of alignment due to normal bumps and vibrations or moving the TV. If you move your TV, or if, after a time, you notice color rings or halos around objects in the picture, you may want to converge (align) the colors.

Properly converged, the lines appear white, which is actually a combination of the outputs of the three color tubes. The output of the green tube is stationary. The outputs of the red and blue tubes can be adjusted. When properly aligned, the outputs of all three tubes should be directly over each other to produce the white lines.

To simplify convergence, HITACHI incorporates a function called MAGIC FOCUS, which the TV to self-adjust. This process will take approximately 90 seconds. If this button is pressed during this 90 second period, no change in picture quality will occur. After this 90 second self-adjust period, picture quality will be optimum. (Do not move the TV during self-adjust.)

To enter this self-adjust mode, you may also select MAGIC FOCUS from the SETUP Menu. However, this will display a message prompting you to press the front panel MAGIC FOCUS button.

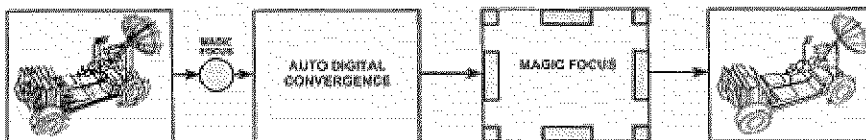

NOTES: Only a momentary press of the MAGIC FOCUS button is necessary to start AUTO DIGITAL CONVERGENCE. At anytime during this convergence correction process, you may press the MAGIC FOCUS button to exit the MAGIC FOCUS mode.

Do not press the MAGIC FOCUS button for more than three seconds. This is only for extreme cases of misconvergence and requires assistance from service. If one of the pictures shown below appears on the television screen, press the MAGIC FOCUS button a second time to exit this manual set up mode.

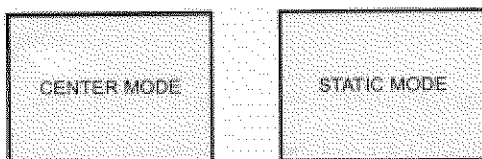

CUSTOM

CUSTOM



This selection contains advanced features which will make TV viewing easier and more enjoyable.

CHANNEL ID

Use this feature to give up to 20 channels a name when ANTENNA signal source is selected and up to 60 channels a name when CATV1 signal source is selected.

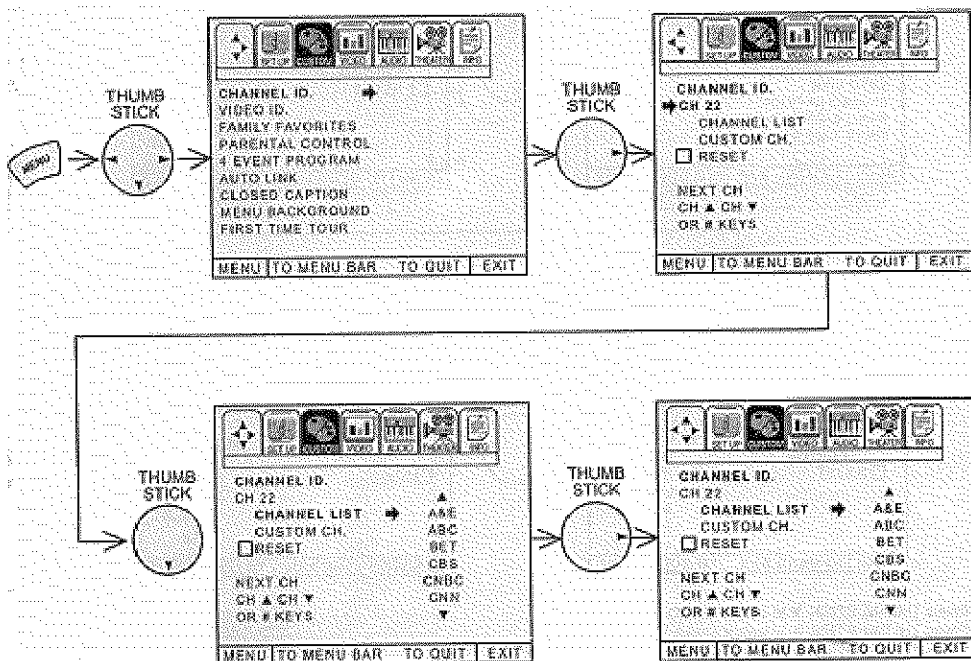

Press THUMB STICK ▼ to select CHANNEL LIST.

Press THUMB STICK ▶ to select preset CHANNEL LIST.

Press THUMB STICK ▼ to scroll through the preset CHANNEL LIST.

Press THUMB STICK ▶ to select desired CHANNEL ID.

To customize CHANNEL ID, select CUSTOM CH.

Press THUMB STICK ▲ or ▼, to select letter.

Press THUMB STICK ◀ or ▶ to change character position.

(*) represents a blank space.

Press CHANNEL ▲ or ▼ and the number buttons to label additional channels.

Press EXIT to quit menu or THUMB STICK ◀ to return to previous menu when the CURSOR is in the first position.

Select RESET to erase a CHANNEL ID.

NOTES:

CUSTOM

If ANT A and ANT B are in the same SIGNAL SOURCE mode (see page 39), the CHANNEL ID for both antenna inputs will be the same. CHANNEL ID will be displayed only when channel is displayed as main picture.

CUSTOM

VIDEO ID.

Use this feature to give a name to any of the two video inputs.

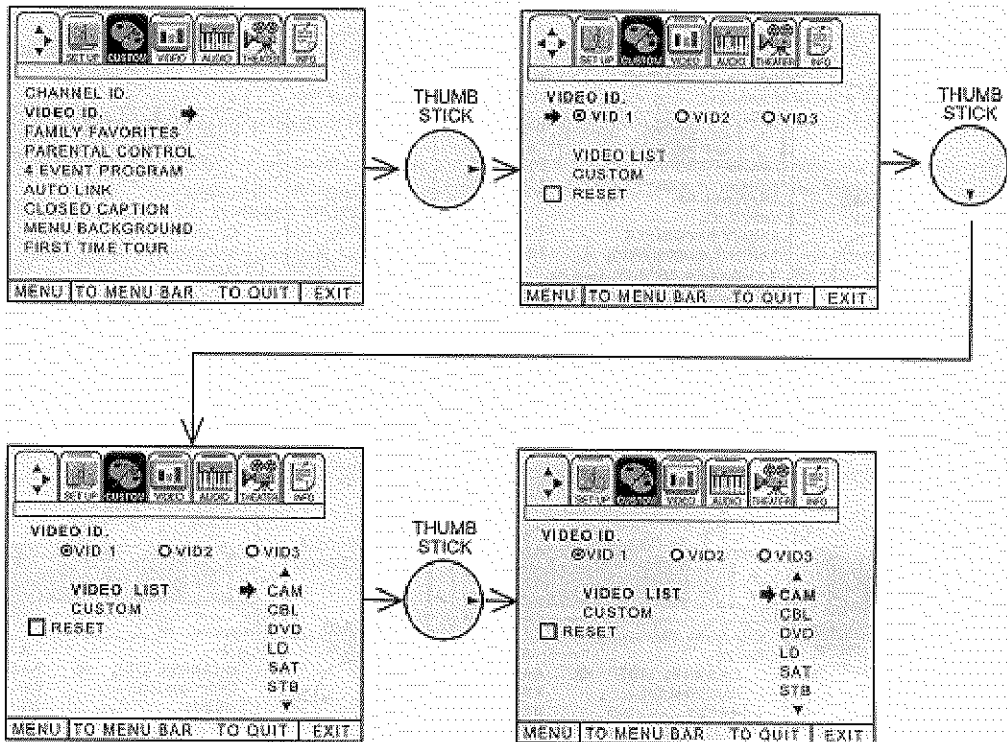

Press THUMB STICK ▼ to select VIDEO LIST.

Press THUMB STICK ▶ to select preset VIDEO LIST.

Press THUMB STICK ▲ or ▼ to scroll through the preset VIDEO LIST.

Press THUMB STICK ▶ to select desired VIDEO ID.

To customize VIDEO ID, select CUSTOM.

Press THUMB STICK ▶ (twice) to select the video input to be named.

Press THUMB STICK ▲ or ▼ to select letters.

Press THUMB STICK ▶ or ◀ to change position.

Press EXIT to quit menu or THUMB STICK ◀ to return to previous menu when the CURSOR is in the first position.

(*) represents a blank space.

Select RESET to set VIDEO ID to original condition.

NOTE: VIDEO ID will be displayed only when VIDEO input is displayed as main picture.

FAMILY FAVORITES (MENU)

This function allows you to group your favorite channels into six personalized categories that

CUSTOM

you can rename. A total of 42 channels can be stored in the FAMILY FAVORITES function.

Channel stored with AUTO CHANNEL SET will automatically be stored in FAMILY FAVORITES.

To rename the categories, use the THUMB STICK buttons to highlight the category you would like to rename.

Use THUMB STICK ▲ or ▼ to change a letter and THUMB STICK ▶ to select the next character to change.

To enter a channel into a category, highlight the channel location to be stored.

Press CHANNEL ▲ or ▼ or the number buttons to enter the desired channel. Repeat until category has been set with your favorite channels. The channel to be added is displayed in the top right corner of the screen.

Enter channel 00 to erase a favorite channel.

To reset categories and channels back to original factory preset, press RECALL while you are renaming a category.

NOTE: This function cannot be accessed when ANT B is the main channel. When the setting in SIGNAL SOURCE is different from ANTA, the message "PLEASE SWITCH TO ANT A" will appear.

CUSTOM

FAMILY FAVORITES (OPERATION)

Use this function to display FAMILY FAVORITES selections as sub-pictures or to tune the main picture to a desired favorite channel.

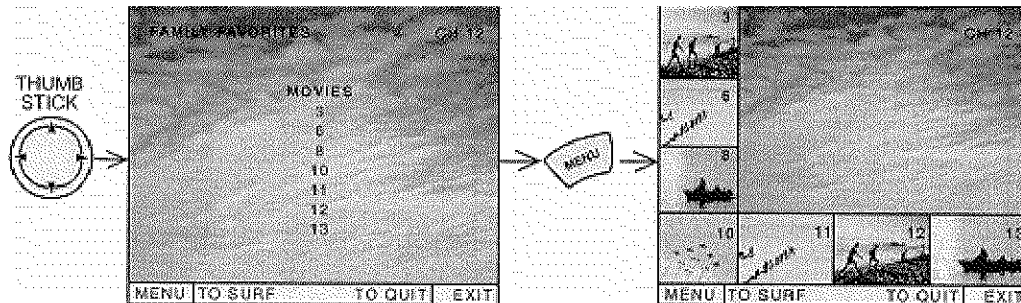

Select a category using THUMB STICK ◀ or ▶ .

Press MENU and the category will be displayed as sub-pictures at the right edge of the screen. This is useful for previewing a category.

Use THUMB STICK ◀, ▶, ▲ or ▼ to highlight a favorite channel and the TV will automatically tune to that channel.

Press EXIT to remove FAMILY FAVORITES OSD from the screen.

NOTE:

If a category has some blank channel entries, these channels will appear as black sub-pictures.

CUSTOM

PARENTAL CONTROL

This function will block out the picture and sound of the selected channel or video input. It can be used to keep the TV from being viewed for a scheduled amount of time that you set.

The code to enter PARENTAL CONTROL is a four digit secret code number. The factory preset code is 0000. Use the number buttons to select secret code.

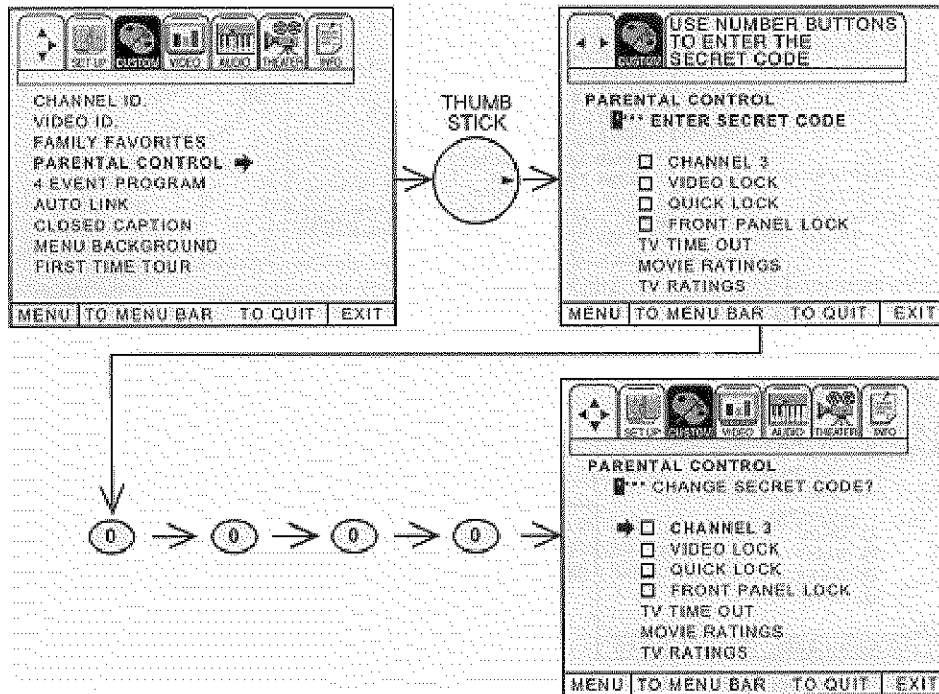

Use THUMB STICK ▲ or ▼ to highlight function and press down on the THUMB STICK to set ON or OFF.

When CHANNEL is turned on, the picture and sound for the chosen channel will be blocked out.

When VIDEO LOCK is turned on, the picture and sound for all video inputs will be blocked out. To lock the video inputs, you must be tuned to any video input.

When QUICK LOCK is turned on, the picture and sound for channels 3, 4 on both ANT A/B and all video inputs will be blocked out.

When FRONT PANEL LOCK is turned on, all buttons on the front panel will be deactivated, except the POWER button.

When TV TIME OUT is turned on, you can set the BEGIN and END times and the TV cannot be viewed during that time period. (Set clock first). Use THUMB STICK ▲ or ▼ to highlight ONCE (TV will time out one time only), DAILY (TV will time out every day), WEEKLY (TV will time out one time a week) or OFF (to disable this function) and then press down on THUMB STICK to SELECT your choice.

MOVIE/TV RATINGS are explained in detail in the Parental Control Movie/TV Ratings Reference Guide.

CUSTOM

To change the secret code number, select CHANGE SECRET CODE. Enter a new four digit key number you prefer.

If you forget your secret code, use the factory code 7777 to erase your key number. This will reset the key number back to the factory preset 0000.

Press EXIT to quit menu or THUMB STICK ◀ to return to the previous menu.

NOTE:

1. If ANT A and ANT B are in the same SIGNAL SOURCE mode (see page 39), when a channel is locked, it is locked on both antenna inputs.
2. When using TV TIME OUT make sure the clock is set (see page 43).

EVENT PROG.

This function will automatically turn the TV on and off, one time only, every day or once a week.

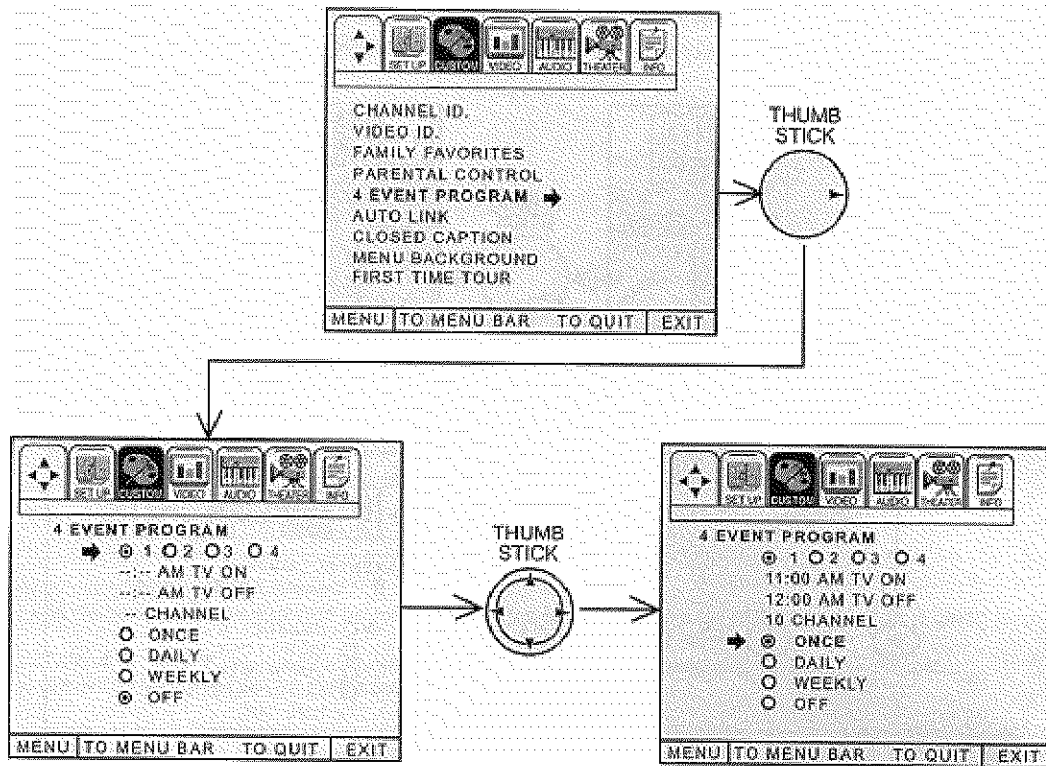

Press THUMB STICK **▶** to select PROGRAM 1, 2, 3, or 4.

Press THUMB STICK **▲** or **▼** to select the time the TV will turn on and off.

Use THUMB STICK **▶** to change position.

Press THUMB STICK **▲** or **▼** to highlight then press down on the THUMB STICK **▶** to select mode ONCE (TV will turn on/off one time only) or mode DAILY (TV will turn on/off at the same time every day), WEEKLY (TV will turn on/off at same time every week) OFF (to disable this function).

Press THUMB STICK **▲** or **▼** or CHANNEL (**▲**) or (**▼**) or number buttons to set the channel the TV will tune to when it automatically turns on.

Press EXIT to quit menu or THUMB STICK **◀** to return to previous menu.

IF the clock is not set, you can not use this function and the screen below will appear.

CUSTOM

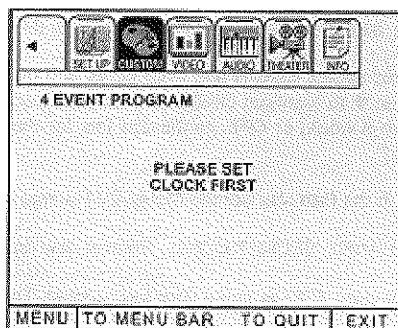

NOTE:

1. The OFF Timer will only activate if the TV was turned on or tuned with the ON Timer, and no channel selection was made after this time. If you change the channel after the ON Timer has been activated, the OFF Timer will deactivate.
2. If no remote control button is pressed after ON Timer is activated, the TV will automatically turn off after three hours.



CAUTION: Do not use your TV as a deterrent when away from home by using the ON and OFF TIMERS. For safety, the TV should be turned off when you are away from home.

CUSTOM

AUTO LINK

Use this function to automatically turn the TV on and tune to VIDEO: 1, 2 or 3 when it detects a VIDEO input.

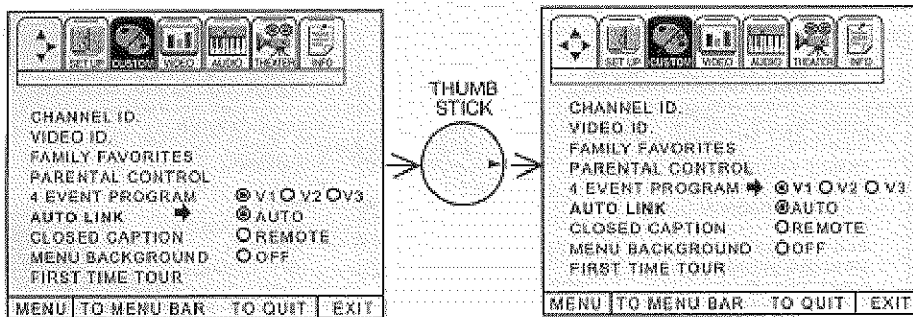

Use THUMB STICK to select Video input.

Use THUMB STICK or , then press down on THUMB STICK to change AUTO LINK setting.

When AUTO is selected, the TV will turn on and tune to VIDEO:1 , 2 or 3 automatically, when the VIDEO: 1 , 2 or 3 input device is turned on. This is convenient when you want to watch a movie with your VCR, laserdisc player or DVD player.

When REMOTE is selected, the TV will turn on and tune to VIDEO: 1 , 2 or 3 automatically, when the VIDEO: 1 , 2 or 3 input device is turned on and the VCR, laserdisc or DVD play button on your remote control is pressed.

This is convenient when you want to record a movie with your VCR and watch it later.

Select OFF to disable this function.

Press EXIT to quit menu or THUMB STICK to return to previous menu.

NOTES:

1. Once the TV has been turned on using the AUTO LINK feature, it must be reset before AUTO LINK is used again. To do this, turn your VCR, laserdisc or DVD player OFF. This feature is now reset and will turn on your TV as described above.
2. When using REMOTE mode, any remote control button will substitute for your video input device play button. However, intended operation is for use with your VCR, laserdisc or DVD play button.

CLOSED CAPTION

Closed captions are the dialogue, narration, and/or sound effects of a television program or home video which are displayed on the TV screen. Your local TV program guide denotes these programs as or .

CUSTOM

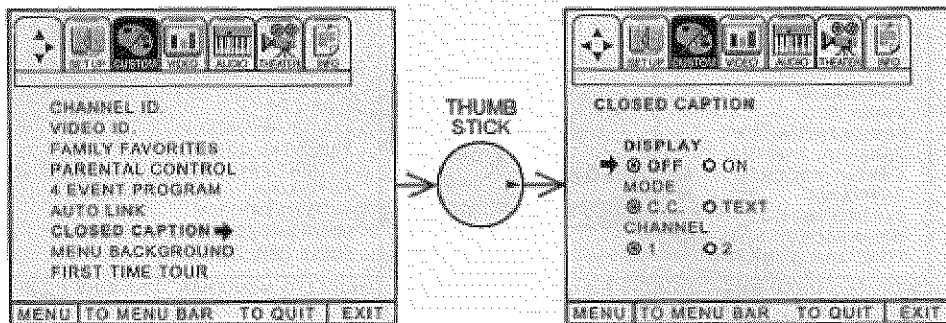

DISPLAY: ON/OFF will turn the  display on or off.

MODE: C.C. (Closed Caption) is for the program you are viewing.

TEXT is for additional information such as news reports or a TV program guide. This information covers the entire screen and viewing the TV program is not possible. TEXT may not be available with every  program.

CHANNEL: 1 is used for the primary language (usually English).

2 is sometimes used for a second language (may vary by region).

Use THUMB STICK ▲ or ▼ to highlight the function to change then press THUMB STICK ► to change the function.

Press EXIT to quit menu or THUMB STICK ◀ to return to previous menu.

NOTE: If you do not have sound, make sure MUTE is not set.

CUSTOM

MENU BACKGROUND

This function allows you to choose from three menu backgrounds.

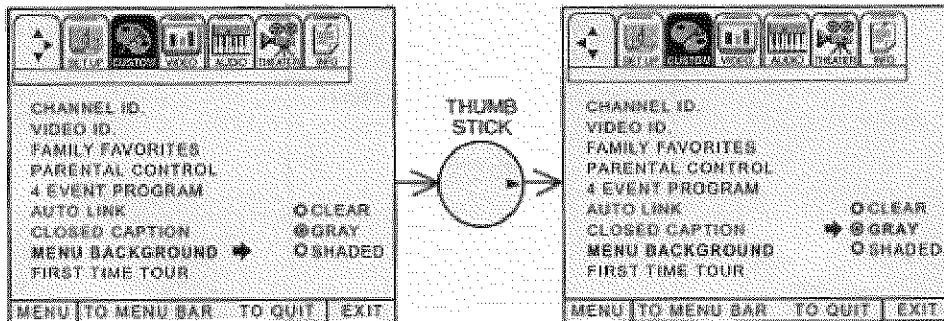

Use THUMB STICK ▲ or ▼ to change MENU BACKGROUND setting.

Press EXIT to quit menu or THUMB STICK ◀ to return to previous menu.

Select CLEAR and no background is visible, select GRAY and a gray background is visible (no picture can be seen behind menu screen), select SHADED and a light background is visible.

FIRST TIME TOUR

This function introduces you to the First Time Tour Setup Feature, showing you basic TV functions as well as helping you set up your TV or Home Theater System. This feature will be displayed every time your TV is turned on, unless you set FIRST TIME TOUR to OFF.

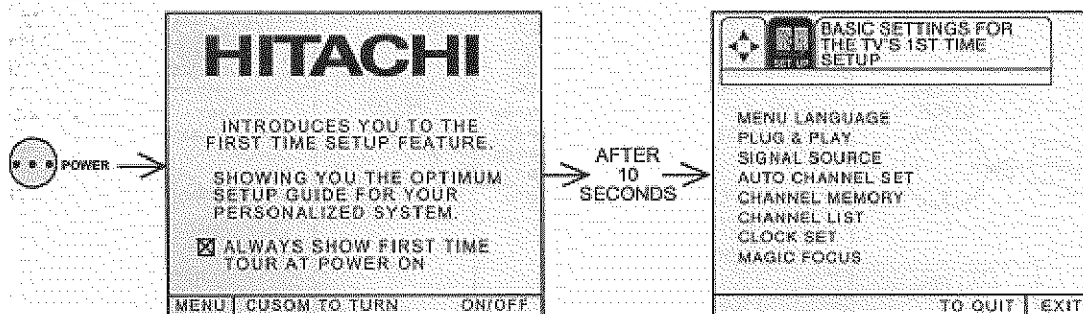

After 10 seconds Auto Demo will start automatically.

To disable this function, press the MENU button at any time during the tour, and the following screen will appear.

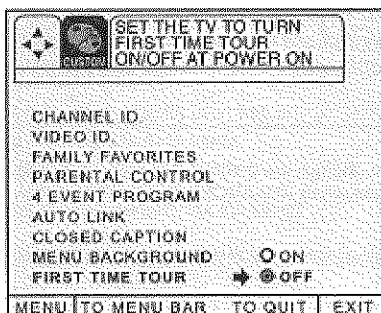

Use THUMB STICK ▲ or ▼ then press down on THUMB STICK to select ON or OFF.

Press EXIT to quit MENU or THUMB STICK ◀ to return to previous menu.

CUSTOM

NOTE: 1. When TV set is turned on, the FIRST TIME TOUR will always appear if it is set to ON.
2. To exit during the FIRST TIME TOUR, press the MENU button.

VIDEO

VIDEO



Select VIDEO to adjust picture settings and improve picture quality.

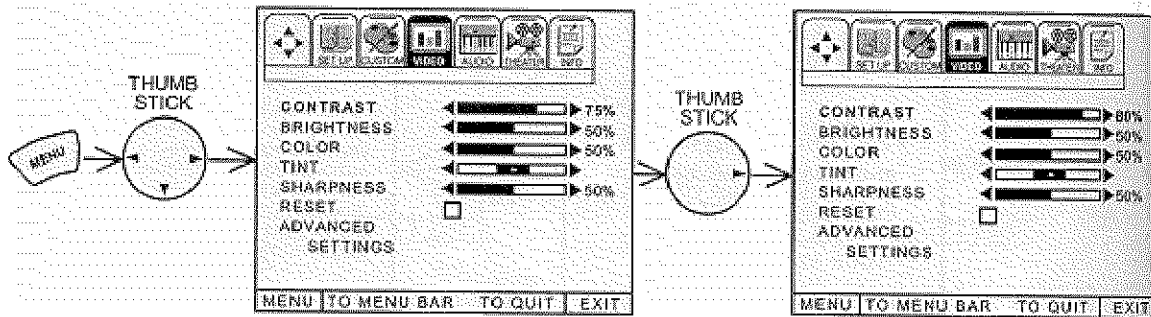

Use the THUMB STICK ▲ or ▼ buttons to highlight the function to be adjusted.
Press the THUMB STICK ◀ or ▶ buttons to adjust the function.
Press EXIT to quit menu.

NOTE:

1. If CONTRAST is selected, you are adjusting CONTRAST. The additional menu items BRIGHTNESS, COLOR, TINT, and SHARPNESS can be selected and adjusted in the same manner.

2. CONTRAST and BRIGHTNESS adjustments will affect only the main picture. These adjustments will not affect the sub-picture.

CONTRAST

Use this function to change the contrast between black and white levels in the picture. This adjustment will only affect the picture when ADVANCED SETTINGS ULTRA AI is OFF. (See page 55)

BRIGHTNESS

Use this function to adjust overall picture brightness.

COLOR

Use this function to adjust the level of color in the picture.

TINT

Use this function to adjust flesh tones so they appear natural. (It may be necessary to adjust TINT to obtain optimum picture quality when using the COMPONENT VIDEO: Y-CB-CR INPUT 2 jacks.)

SHARPNESS

VIDEO

Use this function to adjust the amount of fine detail in the picture.

RESET

When RESET is selected, press down on THUMB STICK to return video adjustments to factory preset conditions.

ADVANCED SETTINGS

Your HITACHI Projection TV has an Ultra AI (Artificial Intelligence) function which will automatically adjust picture settings to produce the highest quality picture possible.

When AI is highlighted, press down on THUMB STICK  to turn the AI on or off.

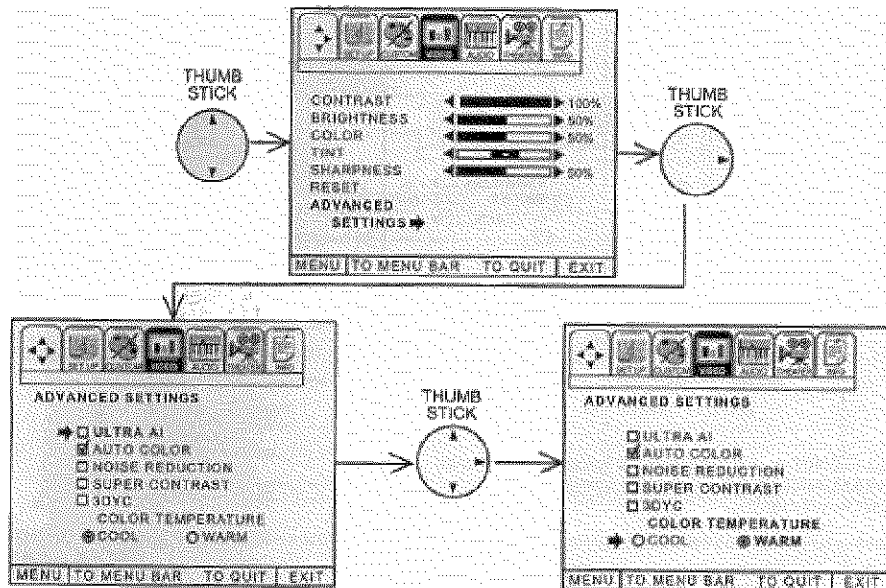

Use the THUMB STICK  or  to select function.

Press down on THUMB STICK to select the function setting. When the function has an " " in the box, it is ON.

Press EXIT to quit menu or THUMB STICK  to return to previous menu.

ULTRA AI (ARTIFICIAL INTELLIGENCE)

When the AI function is on, the TV's internal computer will perform the following:

1. Automatically monitor and adjust contrast depending on room lighting (sensor is located in the front panel) to produce a more natural picture.
2. Automatically monitor and adjust color levels and maintain natural flesh tones.
3. Automatically compensate for weak or strong TV signals to produce a clear picture.

Turn the AI function off to control other PREFERENCE SETTINGS.

AUTO COLOR

The AUTO COLOR function automatically monitors and adjusts the color to maintain constant color levels even after a program or channel changes. It also maintains natural flesh tones while preserving fidelity of background colors. (This function will automatically set to on and cannot be turned off when the ULTRA AI function is ON.)

NOISE REDUCTION

The NOISE REDUCTION function automatically reduces conspicuous noise in the picture without degrading picture quality. (This function will automatically set to on and cannot be turned off when the ULTRA AI function is ON.)

VIDEO

SUPER CONTRAST

Turn on SUPER CONTRAST to improve picture detail in areas of high brightness.

COLOR TEMPERATURE

Set this to WARM for hotter colors with more red, or set to COOL for less intense colors with more blue.



Select AUDIO to adjust the TV to your preference and to improve the sound quality.

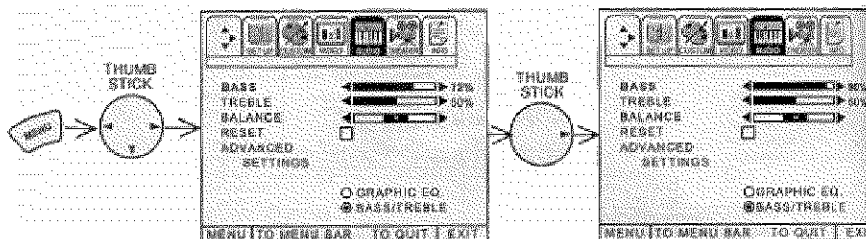

Use THUMB STICK ▲ or ▼ to highlight the function to be adjusted.

Press THUMB STICK ◀ or ▶ to adjust the function.

Press EXIT to quit menu.

NOTE: If BASS is selected you are adjusting BASS. The additional menu items TREBLE and BALANCE can be selected and adjusted in the same manner.

BASS

This function controls the low frequency audio to all speakers.

TREBLE

This function controls the high frequency audio to all speakers.

BALANCE

This function will control the left to right balance of the TV internal speakers, the AUDIO TO HI FI output.

RESET

When RESET is selected, press THUMB STICK ▶ to return audio adjustments to factory preset conditions.

NOTE: If BASS or TREBLE are adjusted, the GRAPHIC EQUALIZER will automatically be disabled.
The BALANCE functions is disabled when SURROUND-DOLBY PRO LOGIC or SURROUND-DOLBY 3 STEREO are selected. (see page 60)

ADVANCED SETTINGS

Use ADVANCED SETTINGS to improve the sound performance of your TV depending on

VIDEO

listening conditions.

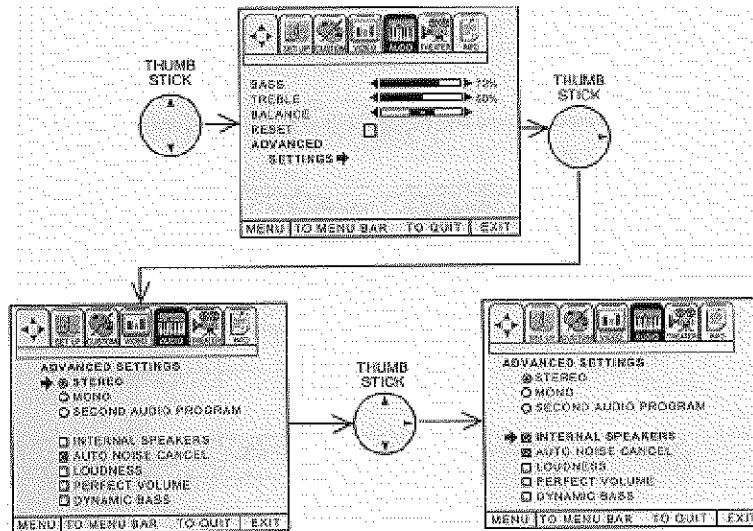

Press THUMB STICK ▲ or ▼ to highlight the function. Press THUMB STICK ▶ to change the function setting. When the function has an "X" in the box, it is ON.

MTS MODE

Multi-Channel Television Sound will allow you to select STEREO (a stereo broadcast), MONO (monaural sound) used when receiving a weak stereo broadcast or SAP (second audio program) which may be a secondary language, weather report, etc.

The sources received will be displayed at the top center edge of the TV. The source you select will be displayed above the sources received. See example below for each selection when both stereo and second audio are received (monaural is always received).

STEREO SELECTED



SAP SELECTED



MONO SELECTED

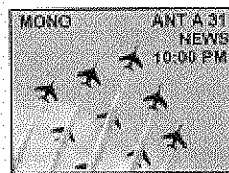

INTERNAL SPEAKERS

This function is useful when first setting up the external speakers, or if you prefer to use only speakers from a separate stereo system.

AUTO NOISE CANCEL

This function eliminates the noise between stations. If a channel is tuned and is noisy, this function will automatically eliminate the audio for that channel.

LOUDNESS

This function will improve the quality of both low and high frequency sounds when listening at low volume levels. (Enabling this function will automatically disable the GRAPHIC EQUALIZER.)

THEATER

PERFECT VOLUME

This function will automatically adjust volume so each channel has the same average volume level. (This function will automatically be disabled when SURROUND-DOLBY PRO LOGIC or SURROUND DOLBY 3 STEREO are selected, to ensure correct DOLBY SURROUND sound decoding.) (see page 60)

DYNAMIC BASS

This function allows you to enjoy spectacular bass sound that would normally be heard only with expensive home speaker systems.

NOTE: If optional left and right speakers are connected while in SURROUND-DOLBY PRO LOGIC (Normal mode) or SURROUND-DOLBY 3 STEREO (Normal mode), the internal speakers may be turned off for better separation between left, center, and right channels (see page 60). The center channel audio will still be heard from the television's center speakers.

THEATER



Use this function to choose picture and audio settings for a true home THEATER experience.

THEATER MODES

Use this function to choose from automatic picture and audio settings to optimize your TV's performance.

THEATER

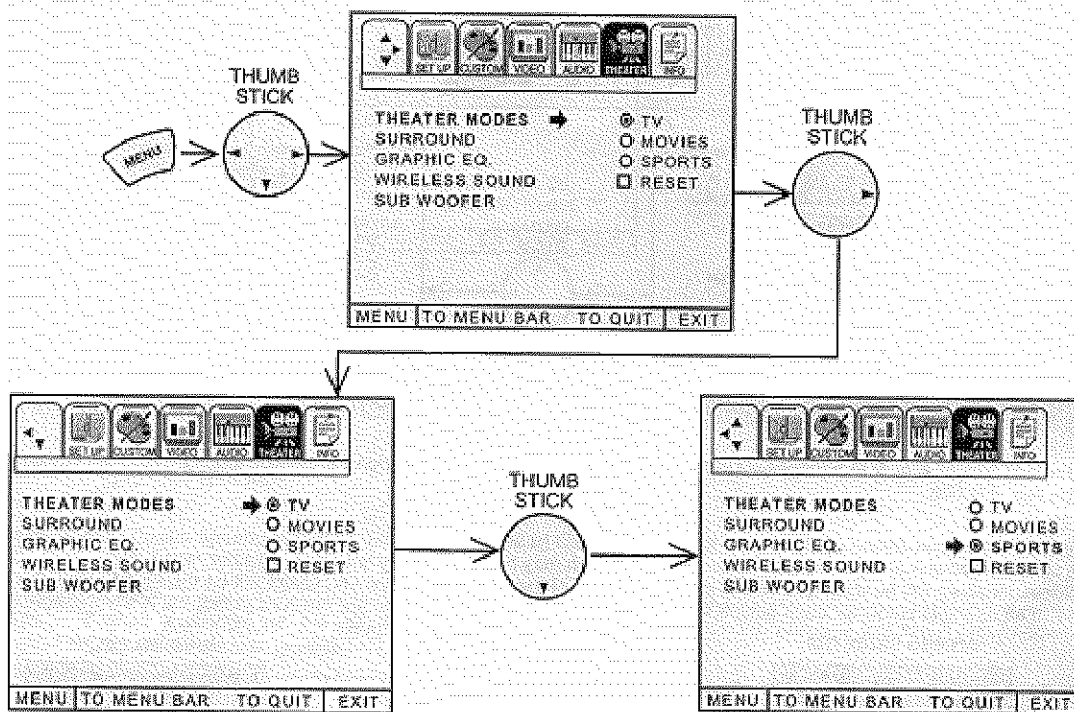

Use THUMB STICK ▲ or ▼ to change THEATER MODES settings.

When TV mode is chosen, the following are automatically set: CONTRAST almost maximum, SUPER CONTRAST-OFF, COLOR TEMP. - COOL, LOUDNESS-ON, PERFECT VOLUME-ON, DYNAMIC BASS-ON.

When MOVIE mode is chosen, the following are automatically set: CONTRAST almost center, SUPER CONTRAST-OFF, COLOR TEMP. - COOL, LOUDNESS-OFF, PERFECT VOLUME-OFF, DYNAMIC BASS-OFF.

When SPORTS mode is chosen, the following are automatically set: CONTRAST - Maximum, SUPER CONTRAST-ON, COLOR TEMP. - COOL, LOUDNESS-OFF, PERFECT VOLUME-OFF, DYNAMIC BASS-OFF.

You can customize each of the above modes (TV, MOVIE, and SPORTS) to your preference to increase viewing performance and pleasure, depending upon the video program being viewed. However, if RESET is selected, all modes will reset to the initial conditions as explained above.

When RESET is selected, it will take approximately two seconds to return to factory conditions (SPORTS mode).

Press EXIT to quit menu or THUMB STICK ◀ to return to previous menu.

THEATER

SURROUND

The following surround settings will reproduce the "live" sound you would hear in concert halls, sports stadiums, movie theaters, etc. when you set up your speaker system as shown in the section on audio system setup on pages 20-21. The surround system is most effective with movie and other stereo material that is Dolby Surround encoded, and played on a stereo VCR.

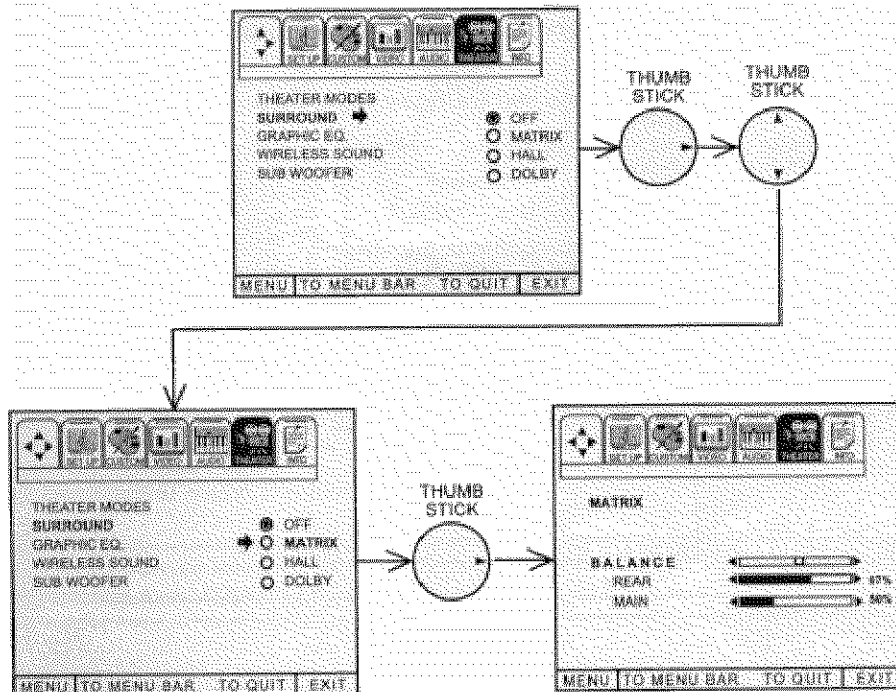

When using WIRELESS SOUND, REAR SPEAKERS mode must be chosen to receive the SURROUND audio program.

To enter the SURROUND MODE, use THUMB STICK ▲ or ▼ to highlight then press down on THUMB STICK ▶ to select SURROUND MODE of your choice.

Now press THUMB STICK ▲ or ▼ to highlight, then press down on THUMB STICK ▶ to select speaker to be adjusted.

Use THUMB STICK ◀ or ▶ to adjust the volume of REAR and MAIN speakers. MAIN volume also controls AUDIO TO HI-FI output level. Adjust MAIN volume first.

Each SURROUND setting has separate MAIN and REAR volume controls, except OFF and DOLBY 3 STEREO which has no rear volume controls. DOLBY PRO LOGIC and DOLBY 3 STEREO also have CENTER volume controls, while MATRIX and HALL have BALANCE controls. (Balance while in DOLBY PRO LOGIC and DOLBY 3 STEREO modes is adjusted by using the TEST TONE volume controls. The CENTER and REAR volume will increase or decrease when MAIN is adjusted, keeping an equal balance between the SURROUND channels.

THEATER

The maximum volume allowed for the CENTER and REAR will depend on how loud the MAIN volume is set.

SURROUND OFF

Use this for normal stereo/mono broadcasts.

MATRIX SURROUND

Listener is surrounded by many sound sources such as a sporting event.

NOTE:

Some TV systems do not transmit optimum audio channel separation which can reduce the effectiveness of the MATRIX SURROUND function.

HALL SURROUND

Resonant sound-Listener has the feeling of being in a concert hall.

THEATER

DOLBY PRO LOGIC

Dolby Pro Logic provides four separate sound channels: front left, center, front right, and surround. For properly encoded programs marked  the center sound channel contains the dialogue for the program viewed. The left and right channels produce sound effects that will match the action on the TV screen. For example, Dolby Pro Logic will enhance the effect of a car viewed driving from the left side of the TV screen to the right side. The surround channel (speakers) are placed behind the viewing area to add additional spatial sound effects.

To fully benefit from Dolby Pro Logic Surround, it is recommended that the surround speaker system be complete, as shown on page 20.

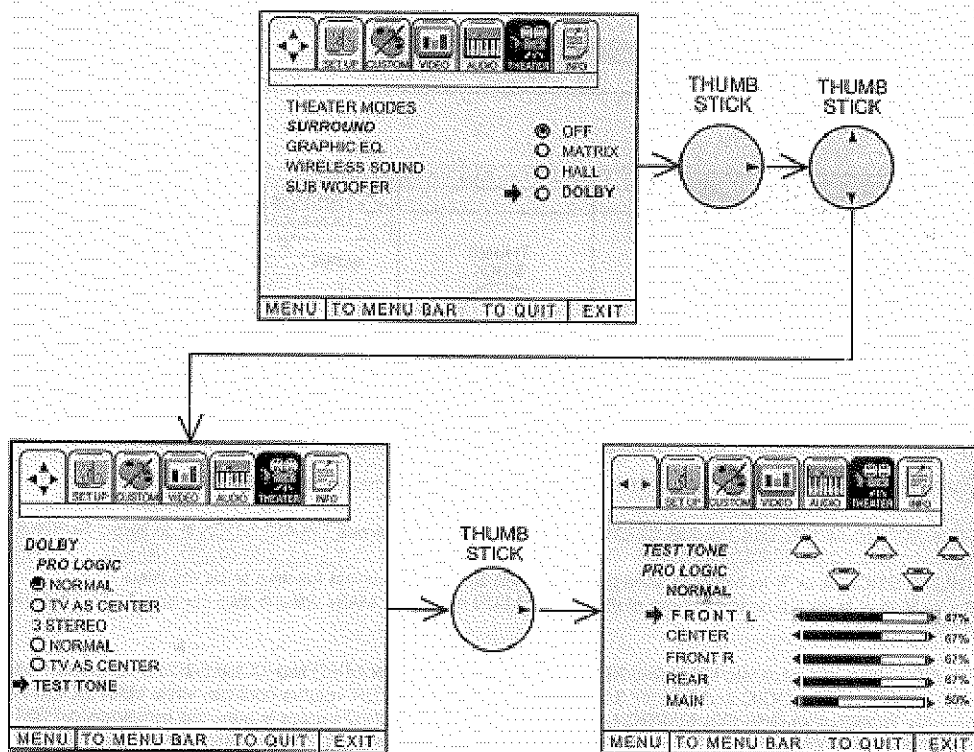

Press THUMB STICK ▲ or ▼ to highlight a surround function.

Use THUMB STICK ► to change the surround function.

The function can be set to DOLBY 3 STEREO or DOLBY PRO LOGIC. When DOLBY 3 STEREO is set, the surround channel sound is split equally between the left and right speakers of the separate audio amplifier. When DOLBY PRO LOGIC is set, separate surround sound speakers must be used.

Also, the function can be set to NORMAL or TV AS CENTER. When NORMAL is set, center channel sound is sent to the TV center speakers, while left and right audio is sent to the TV's left and right speakers. When TV AS CENTER is set, center channel sound is sent to the TV center speakers while left and right audio is sent to the left and right speakers of a separate audio amplifier (TV's left and right speakers are automatically turned off).

THEATER

TEST TONE

A test sound is generated allowing the listener to balance volume from each channel. Adjust the volume levels until all channels are equal.

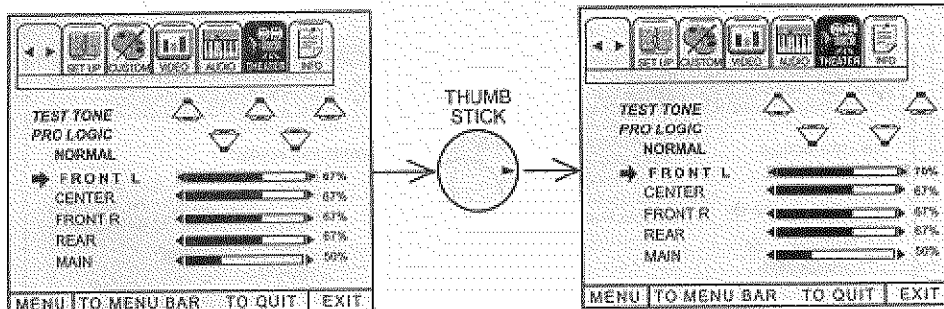

DOLBY PRO LOGIC

DOLBY 3 STEREO

Press THUMB STICK ▲ or ▼ to highlight, then press THUMB STICK ▶ to select TEST TONE.

Automatic scanning of applicable speakers for your chosen Surround mode will occur. Simply wait until the speaker you wish to adjust is highlighted (static noise will be heard from this speaker), then use THUMB STICK ◀ or ▶ to adjust VOLUME. (Adjust balance by adjusting Front L and Front R volume control.)

Press EXIT to quit menu or MENU to return to previous menu.

NOTE: When in Dolby Surround Mode, the AUDIO-ADVANCED SETTINGS-PERFECT VOLUME feature will automatically be disabled to ensure correct DOLBY SURROUND sound decoding.

GRAPHIC EQUALIZER

Use this function to precisely control tonal quality by using seven different frequency controls.

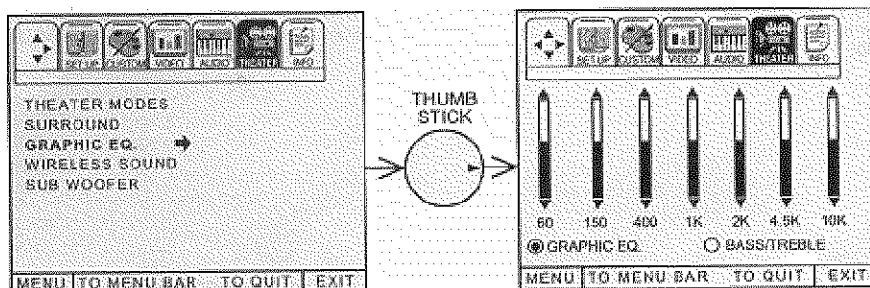

Press THUMB STICK ▶ to select the frequency you wish to adjust.

To increase the amount of frequency audio to all speakers, use THUMB STICK ▲.

To decrease the amount of frequency audio to all speakers, use THUMB STICK ▼.

Press EXIT to quit menu or THUMB STICK ◀ to return to previous menu when the

THEATER

CURSOR is in the first position.

NOTE: When this function is used or adjusted, the **AUDIO SETTINGS** functions **BASS** and **TREBLE** will be disabled and **LOUDNESS** will be set to off.

THEATER

WIRELESS SOUND

This feature allows you to choose between two possible variable audio outputs for a separate set of wireless speakers or another stereo amplifier. The audio output may be either MAIN TV AUDIO or PIP AUDIO.

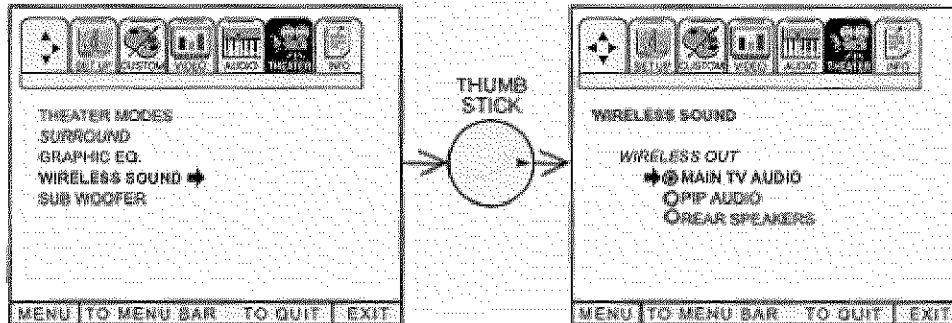

Press THUMB STICK ▲ or ▼ to highlight a function.

Press THUMB STICK ► to select the function.

Press EXIT to quit menu or THUMB STICK ◀ to return to previous menu.

MAIN TV AUDIO

When set to MAIN TV AUDIO mode, your wireless speakers will play the same audio program as played on your TV. The volume of your wireless speakers will be controlled by the TV volume control.

PIP AUDIO

When set to PIP AUDIO mode, your wireless speakers will play the PIP sub-picture audio program. The volume of your wireless speakers will now be controlled by the PIP VOLUME control, which may be varied from 0 (min.) to 100 (max.). If no sub-picture is displayed, the wireless speakers will play the main channel audio program with the volume being controlled by the TV volume control.

REAR SPEAKERS

When set to REAR SPEAKERS mode, your wireless speakers will play the surround audio program. The volume of your wireless speakers will be controlled by the TV volume control, dependent upon the amount of REAR selected from SURROUND mode. (see pages 59 and 60)

SUB WOOFER

Use this feature to provide variable audio output to an optional sub woofer.

THEATER

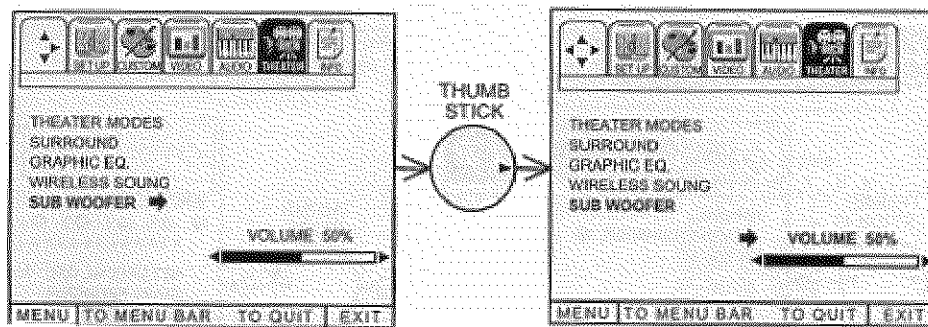

Press THUMB STICK ▼ to select volume adjustment bar.

Press THUMB STICK ◀ or ▶ to adjust SUB WOOFER volume.

Press EXIT to quit menu or THUMB STICK ▲ to highlight VOLUME, then THUMB STICK ◀ to return to previous menu.

NOTE: The SUB WOOFER volume will increase or decrease when main volume is adjusted.

INFO



This function allows your TV to assist you with your busy day-to-day schedule.

SPECIAL EVENT REMINDER

Use this function to set up to six special events into memory. These events can then be viewed in CALENDAR mode.

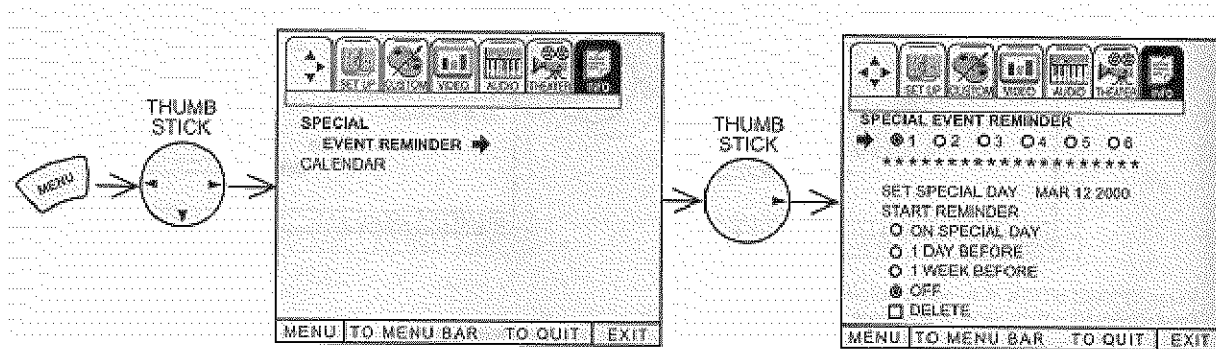

- Press THUMB STICK to select EVENT 1 to 6.
- Press THUMB STICK or to select a letter.
- Press THUMB STICK to change position.
- Set Special Day of reminder using cursor buttons.

Highlight the day of START REMINDER using THUMB STICK, then press THUMB STICK to select.

To erase SPECIAL EVENT, select DELETE then press THUMB STICK .

Press EXIT to quit menu or THUMB STICK to return to previous menu.

If the clock is not set, you can not use this function and the next screen will appear.

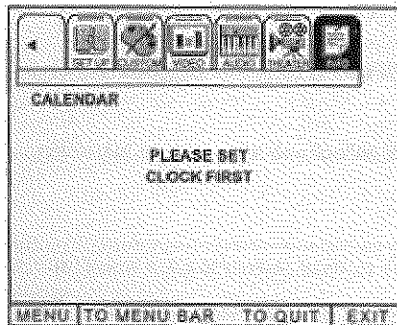

NOTE:

1. When the TV is turned on, the SPECIAL EVENT REMINDER message will automatically

INFO

appear at the selected time.

2. Each special event message can be a maximum of 20 characters.

3. When the RECALL button is pressed, a special icon appears on the right bottom corner of the screen and indicates a SPECIAL EVENT REMINDER message. Press the RECALL button again to display the SPECIAL EVENT REMINDER message.

CALENDAR

Use this function to check the day, month, and year.

Dates programmed in SPECIAL EVENT REMINDER will appear blinking and special event message will be displayed.

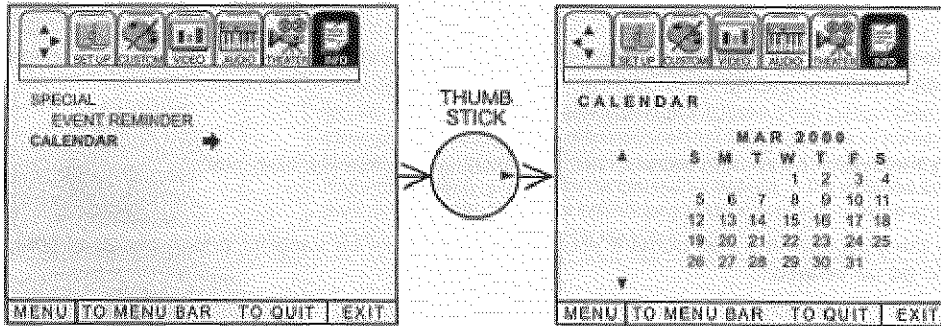

Press THUMB STICK ▲ or ▼ to change the month.

Press EXIT to quit menu or THUMB STICK ◀ to return to previous menu.

If the clock is not set, you can not use this function and the next screen will appear.

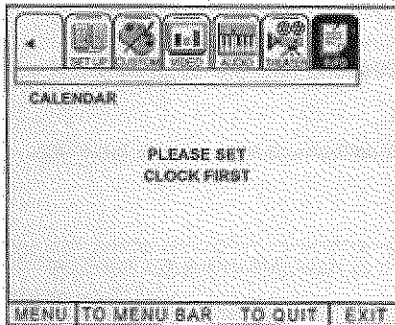

NOTES:

1. Dates of SPECIAL EVENT REMINDER will appear blinking. Special event message will be displayed only if current date is within the day of Start Reminder Specifications as chosen in SPECIAL EVENT REMINDER. (see page 64)
2. A special icon appears next to CALENDAR when a SPECIAL EVENT REMINDER is set.

CARE OF YOUR HITACHI PROJECTION TV AND YOUR

REMOTE CONTROL

DO

Dust the screen and cabinet with a soft cloth.

Clean the screen with a soft cloth moistened with warm water and dry with a soft cloth. A mild soap may be used if the screen is extremely dirty.

Place your television away from extreme heat, humidity and extremely dusty places.

Remove the plug from the wall outlet if your television will not be used for a long period of time, for instance, when you go on vacation

DO NOT

Do not clean your screen or cabinet with strong cleaners, polishes or a chemically treated cloth.

Do not place rubber or vinyl products or cellophane tape on your television.

Do not touch the screen too often.

Do not subject the remote control to shocks such as dropping it on the floor, etc. Physical damage to the precision parts may result.

Avoid placing the remote control in a high humidity place or getting it wet. Don't leave it on or near a heater. Excessive heat or moisture may cause the unit to cease operation.

When the batteries run down, remote control operation will become erratic or possibly stop altogether. Replace the old batteries with two new "AA" size batteries.

Exposure of the viewing screen to prolonged direct sunlight or heat may cause the screen to permanently warp, resulting in a distorted picture.

RECEPTION PROBLEMS

RECEPTION PROBLEMS

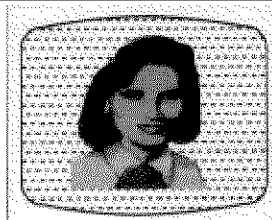

• IGNITION NOISE:

Black spots or horizontal streaks may appear, picture may flutter or drift. Usually caused by interference from automobile ignition systems, neon lamps, electrical drills and other electrical appliances.

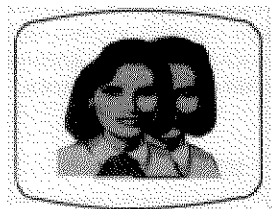

• GHOSTS:

Ghosts are caused by the television signal following two paths. One is the direct path and the other is reflected from tall buildings, hills or some other objects. Changing the direction or position of the antenna may improve reception. Ghosting may also be caused by defects in the antenna system such as unshielded leads or connecting several sets to the same antenna without using multiple antenna couplers.

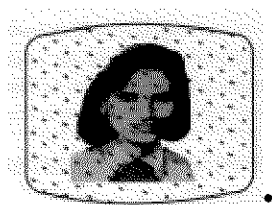

• SNOW:

If your receiver is located in the fringe area of a television station where the signal is weak, your picture may be marred by the appearance of small dots. When the signal is extremely weak, it may be necessary to install a special antenna to improve the picture.

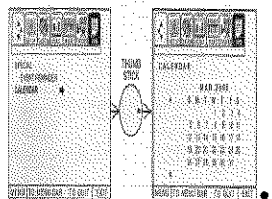

• RADIO FREQUENCY INTERFERENCE:

The interference produces moving ripples or diagonal streaks, and in some cases, causes loss of contrast in the picture.

NOTE: The TV set can generate sound distortion in external devices such as a radio. Please separate radio equipment from the TV set to a considerable distance.

USEFUL INFO

USEFUL INFO

	Check these items and try these adjustments									
SYMPTOMS	Be sure external connection is correct	Be sure power cord is plugged in	Be sure TV is switched "ON"	Try another channel (station trouble)	Check antenna connections (back of TV)	Check antenna for broken lead-in wire	Check outside antenna	Check for local interference	Adjust contrast control	Adjust brightness control
No picture, no sound										
Sound OK, picture poor										
Picture OK, sound poor										
Picture blurred										
Lines or streaks in picture										
Poor reception on some channels										
Picture rolls vertically										
No color										
Poor color										

HITACHI Projection Television incorporates advanced power surge protection technology designed to protect against component or circuit damage due to external or internal voltage power surges.

IF YOUR TELEVISION SHOULD APPEAR TO HAVE A LOSS OF POWER, PLEASE FOLLOW THIS PROCEDURE:

- 1) Press the power switch (ON/OFF switch) once.
- 2) If there is still no power, wait 30 seconds and press the power switch again.
- 3) If there is still no power, unplug the power cord from the wall. Wait 30 seconds and plug the power cord back in. Press the power switch again.

This protective technology should provide for years of lasting entertainment from your HITACHI Projection Television.

USEFUL INFO

Features:

- Superfine Picture Quality 1000 Line Horizontal Resolution
- Pure Green and Red Filter Lenses
- Artificial Intelligence System
- Remote (Controls many VCR brands, cable boxes, satellite boxes, and other audio equipment)
- High Definition On-Screen Display (UltraTEC BIT-MAP)
- ON SCREEN PLUG and PLAY guide
- Full Set of Input Jacks, including S-VIDEO
- COMPONENT VIDEO: Y/CB/CR
- Closed Caption Decoder
- High Resolution Picture-In-Picture with Freeze
- Tuned Port Bass Reflex Speakers
- Magic Focus (Auto Digital Convergence)
- Dual Antenna Inputs
- Auto Link
- 3 Dimensional Y/C Comb Filter
- Dolby Pro Logic*Hall/Matrix 3 Stereo Surround Sound

* "Dolby", the double-D symbol, and (where applicable) "Pro Logic" are trademarks of Dolby Laboratories Licensing Corporation. Manufactured under license form Dolby Laboratories Licensing Corporation. Additionally licensed under one or more of the following patents: U.S. number 3,959,590; Canada numbers 1,004,603 and 1,037,877. "Dolby", "Pro Logic", and the double-D symbol are trademarks of Dolby Laboratories Corporation.

USEFUL INFO

Inputs:

- Power Input.....AC 120V, 60Hz
- Power Consumption (operating)
53SBX01B 161W
61SBX01B 161W
- Power Consumption (maximum)
53SBX01B.....210W
61SBX01B.....210W
- Antenna input impedance.....75 Ohm
- Channel coverage.....181 ch.
VHF-Band.....2 ~ 13
UHF-Band.....14 ~ 69
CATV Mid Band.....A-5 ~ A-1
..... A-1
Super Band.....J-W
Hyper Band.....W+1 - W+28
Ultra Band.....W+29 - W+84
- Video.....1.0Vp-p, 75 Ohm
- S-Video
Luminance (Y).....1.0Vp-p, 75 Ohm
Chrominance (C).....0.286Vp-p, 75 Ohm
- Component Video
Luminance (Y).....1.0Vp-p, 75 Ohm
Chrominance (Pb/Cr).....0.7Vp-p, 75 Ohm
- Audio input level.....47k Ohm
- Average input level.....470mVrms

Outputs:

- Video.....1.0Vp-p, 75 Ohm
- Audio.....470mVrms, 1k Ohm

Dimensions:

53SBX01B

- Height (in.) 55 3/4
- Width (in.) 46
- Depth (in.) 26 1/4
- Weight (lbs) 200

61SBX01B

- Height (in.) 61 1/2
- Width (in.) 52 1/2
- Depth (in.) 29

USEFUL INFO

- Weight (lbs) 320

USEFUL INFO

NOTE: Due to improvements, specifications in this operating guide are subject to change without notice.

HITACHI SERVICE HOTLINE

To locate an authorized HITACHI service facility in the continental U.S.A. and Canada,

DIAL TOLL FREE

7 days a week, 24 hours a day

800 HITACHI

(1-800-448-2244)

**Hitachi America, LTD
Home Electronics Division**

Hitachi has made every effort to assure you hours of trouble free operation from your unit. However, should you require service, a network of Hitachi Authorized Service Facilities has been established in all 50 states and Puerto Rico. Each facility will provide you with convenient and expedient assistance. Our service hotline operator will direct you to the Hitachi Authorized Service Facility nearest you. Just present proof of purchase and/or delivery receipts to the Hitachi Authorized Service Facility, and service will be rendered in accordance with the terms of the limited warranty as stated on your warranty card or operating guide.

Should you have any questions regarding warranty, service, operation or technical assistance, please contact:

**Hitachi America LTD.
Home Electronics Division
1855 Dornoch Court
San Diego, CA 92154**

***In Canada, please contact 1-800-HITACHI
(1-800-448-2244)***

**HITACHI (HSC) Canada Inc
6740 Campobello Road
Mississauga, Ont. L5N 2L8-**

NOTES

NOTES

(blank page for consumer notes)

Back cover

Back cover

HITACHI