

Owner's Manual

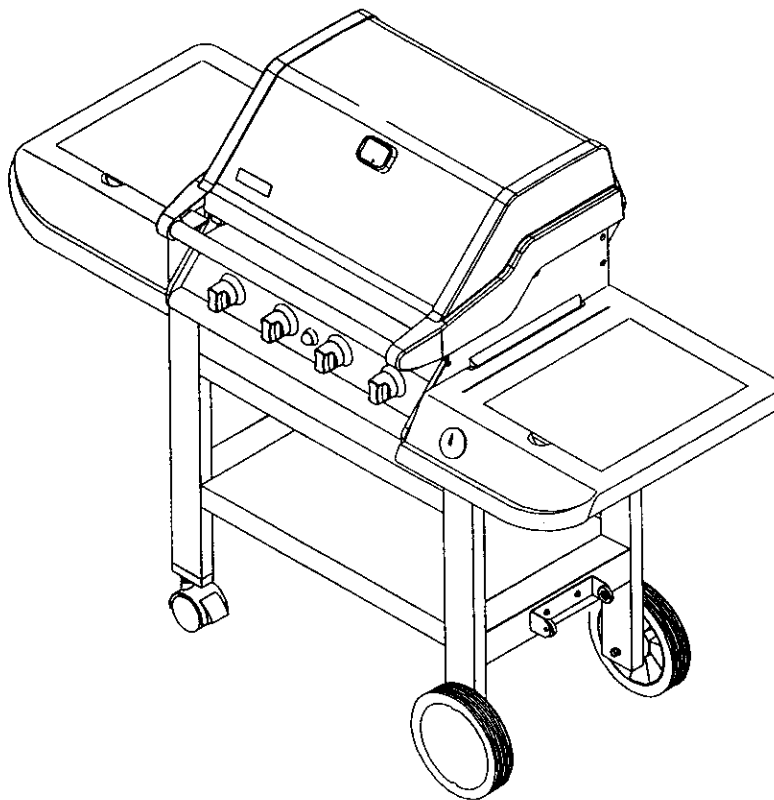

Liquid Propane Gas Grill

Model 141.156400



WARNING:

Read this Owner's Manual carefully and be sure your gas grill is properly assembled, installed and maintained. Failure to follow these instructions could result in serious bodily injury and/or property damage. This gas grill is intended for outdoor use only and is not intended to be installed in or on recreational vehicles or boats.

Note to Installer:

Leave this Owner's Manual with the consumer after delivery and/or installation.

Note to Consumer:

Leave this Owner's Manual in a convenient place for future reference.

Manufacturer's Customer Service Helpline:

If there are damaged or missing parts when you unpack this unit from the shipping box, or you have questions about assembly, call us 8am - 8pm CST, Monday through Friday at:

1-888-317-7642

**Sears, Roebuck and Co.,
Hoffman Estates, IL 60179 U.S.A.**

P4795A - Date:11/21/00

Table of Contents

Warranty	2
Safety Instructions	2
Pre-Assembly Instructions	4
Hardware, Parts Diagram and Lists	5
Assembly Instructions	8
Lighting Instructions	13
Cleaning and Maintenance Instructions	15
Frequently Asked Questions	17
Cooking Instructions	18
Cooking Guide and Recipes	24

Kenmore Elite Grill Warranty

Full 1-Year Warranty on Grill

For one year from the date of purchase Sears will repair or replace, at our option, any grill part (except for paint loss and ignitor battery) that is defective in material or workmanship.

Limited Warranty on Selected Grill Parts

From one year after the date of purchase for the designated time periods listed below, Sears will replace the following grill parts if they are defective in material or workmanship. You will be charged for labor.

- Lifetime of Grill: Exterior Stainless Steel Parts, Aluminum Castings (except for paint loss)
- 2 Years: Flame Tamers, Cooking Grids, Burners
- 4 Years: All Other Grill Parts (except ignitor battery)

Warranty Service

Warranty service is available by contacting your nearest Sears Service Center.

Warranty Restrictions

- This warranty is void if grill is used for commercial or rental purposes.
- This warranty applies only when the grill is used in the United States.
- This warranty gives you specific legal rights, and you may also have other rights which vary from state to state.

Sears, Roebuck and Co., Dept. 817WA,
Hoffman Estates, IL 60179

Read These Safety Instructions

WARNING

Combustion by-products produced when using this product contain chemicals known to the State of California to cause cancer, birth defects, or other reproductive harm.

WARNING

Failure to comply with these instructions could result in a fire or explosion that could cause serious bodily injury, death, or property damage.

Grill Installation Codes

This gas grill must be installed in accordance with all local codes. In areas without local codes, follow the latest edition of the National Fuel Gas Code ANSI Z223.1. In Canada, installation must conform to standard CAN/CGA 1b149.1 or 1-b149.2 (Installation Code for Gas Burning Appliances and Equipment) and all local codes.

Correct LP Gas Tank Use

LP gas grill models are designed for use with a standard 20 lb. Liquid Propane Gas (LP gas) tank; not included with grill box. Never connect your gas grill to an LP gas tank that exceeds this capacity. A tank of approximately 12 inches in diameter by 18-1/2 inches high is the maximum size LP gas tank to use. We recommend buying an "OPD" gas tank which offers an Overfill Prevention Device. This safety feature prevents the tank from being overfilled which can cause malfunction of the LP gas tank, regulator and/or grill.

The LP gas tank must be constructed and marked in accordance with specifications of the U.S. Dept. of Transportation (DOT). In Canada, the LP gas tank must meet the Canadian Transportation and Communications (CTC) specifications. Also be sure:

1. The LP gas tank has a shutoff valve, terminating in an LP gas supply tank valve outlet, that is compatible with a Type 1 tank connection device. The LP gas tank must also have a safety relief device that has a direct communication with the vapor space of the tank.
2. The tank supply system must be arranged for vapor withdrawal.
3. The LP gas tank used must have a collar to protect the tank valve.

Proper Placement and Clearance of Grill

Never use your gas grill in a garage, porch, shed, breezeway or any other enclosed area. Your gas grill is to be used **outdoors only**, at least 24 inches from the back and side of any combustible surface. Your gas grill should not be placed under any surface that will burn. Do not obstruct the flow of ventilation air around the gas grill housing.

This outdoor gas grill is not intended to be installed in or on recreational vehicles and/or boats.

WARNING

Failure to comply with these instructions could result in a fire or explosion that could cause serious bodily injury, death, or property damage.

- Never connect an unregulated LP gas tank to your gas grill. The gas regulator assembly supplied with your gas grill is adjusted to have an outlet pressure of 11" water column (W.C.) for connection to an LP gas tank.
- Only use the regulator and hose assembly supplied with your gas grill. Replacement regulators and hose assemblies must be those specified by Sears.
- Have your LP gas tank filled by a reputable propane gas dealer and visually inspected and re-qualified at each filling.
- Never fill the gas tank beyond 80% full. Have your propane gas dealer check the release valve after every filling to ensure that it remains free of defects.
- Always keep LP gas tanks in an upright position.
- Do not store (or use) gasoline or other flammable vapors and liquids in the vicinity of this gas grill.
- An LP gas tank that is not connected for use must not be stored in the vicinity of this or any other gas grill.
- Do not subject the LP gas tank to excessive heat.
- Never store an LP gas tank indoors. If you store your gas grill in the garage or other indoor location, **always** disconnect the LP gas tank first and store it safely outside.
- LP gas tanks must be stored outdoors in a well-ventilated area. Disconnected LP gas tanks must not be stored in a building, garage or any other enclosed area.
- When your gas grill is not in use the gas must be turned off at the LP gas tank.
- The regulator and hose assembly must be inspected before each use of the grill. If there is excessive abrasion or wear or if the hose is cut, it must be replaced prior to the grill being used again.
- Keep the gas regulator hose away from hot grill surfaces and dripping grease. Avoid unnecessary twisting of hose. Visually inspect hose prior to each use for cuts, cracks, excessive wear or other damage. If the hose appears damaged do not use the

gas grill. Call Sears at 1-800-4-MY-HOME for a Sears authorized replacement hose.

- Never light your gas grill with the lid closed or before checking to insure the burner tubes are fully seated over the gas valve orifices.
- Never allow children to operate your grill. Do not allow children to play near your grill.

WARNING

A strong gas smell, or the hissing sound of gas indicates a serious problem with your gas grill or the LP gas tank. Failure to immediately follow the steps listed below could result in a fire or explosion that could cause serious bodily injury, death, or property damage.

- Shut off gas supply to the gas grill.
- Turn the control knobs to OFF position.
- Put out any flame with a fire extinguisher.
- Open grill lid.
- Get away from the LP gas tank.
- Do not try to fix the problem yourself.
- If odor continues or you have a fire you cannot extinguish, call your fire department. Do not call near the LP gas tank because your telephone is an electrical device and could create a spark resulting in fire and/or explosion.

CAUTION: BEWARE OF FLASH-BACK

CAUTION: Spiders and small insects occasionally spin webs or make nests in the grill burner tubes during transit and warehousing. These webs can lead to a gas flow obstruction which could result in a fire in and around the burner tubes. This type of fire is known as a "FLASH-BACK" and can cause serious damage to your grill and create an unsafe operating condition for the user.

Although an obstructed burner tube is not the only cause of "FLASH-BACK", it is the most common cause.

To reduce the chance of "FLASH-BACK", you must clean the burner tubes before assembling your grill, and at least once a month in late summer or early fall when spiders are most active. Also perform this burner tube cleaning procedure if your grill has not been used for an extended period of time.



Pre-Assembly Instructions

To reduce the chance of "FLASH-BACK" (see **CAUTION** on page 3) clean the burner tubes and burners **before** fully assembling your grill. Remove the cotter pin from the rear underside of each burner using a pair of long nose pliers. Carefully lift each burner up and away from the gas valve orifice, then refer to **Figure 1** and perform one of these three cleaning methods:

1. Bend a stiff wire, (a lightweight coat hanger works well) into a small hook as shown below. Run the hook through the burner tube and inside the burner several times to remove any debris.
2. Use a bottle brush with a flexible handle. Run the brush through the burner tube and inside the burner several times, removing any debris.
3. Use an air hose to force air through each burner tube. The forced air should pass debris or obstructions through the burner and out the ports.



Figure 1

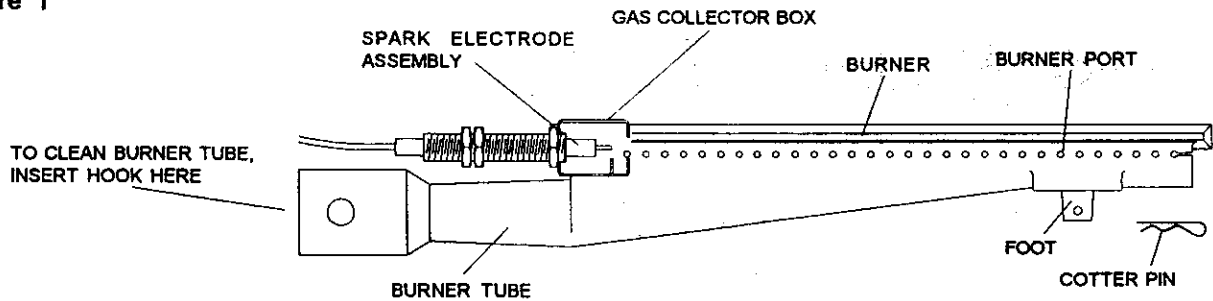

WARNING

The location of the burner tube with respect to the orifice is vital for safe operation. Check to ensure the orifice is inside of the burner tube before using your gas grill. See **Fig. 2**. If the burner tube does not fit over the valve orifice, lighting the burner may cause explosion and/or fire.

Figure 2

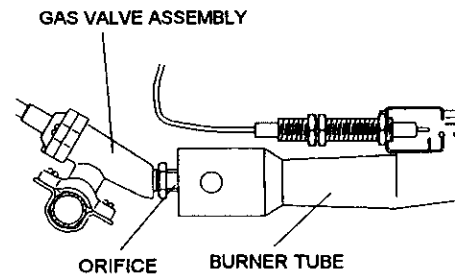

Tools Required for Assembly

- Size 2 phillips screwdriver
- Size 4 phillips screwdriver
- Adjustable wrench
- Long nose pliers
- Open-end wrench, 11/16" size
- Protective work gloves
- Eye protection

Contents for Hardware Pack (Part #P55D9A)

The following table illustrates a breakdown of the hardware pack. It highlights what components are used in the various stages of assembly.

Ref.	Component	Qty. to Use	Purpose of Components
H005	1/4"x1/2" Phillips Head Screw	4	Install Bottom Shelf To Cart Legs
H001	3/8" Wheel Bolt	2	Install Wheels To Cart Legs
H002	Spring Washer	2	
H003	3/8" Nut	2	
H005	1/4"x1/2" Phillips Head Screw	8	Install The Two Braces To Cart
H005	1/4"x1/2" Phillips Head Screw	4	Restrict Drawer From Being Pulled Out Too Far
H005	1/4"x1/2" Phillips Head Screw	2	Install Pressure Cylinder Holder To Cart
H005	1/4"x1/2" Phillips Head Screw	2	Install Tank Guide To Cart
H012	1/4"x1-3/8" Phillips Head Screw	4	Install Grill Head To Cart
H009	1/4" Lock Nut	4	
H004	1/4"x3/4" Phillips Head Screw	8	Install Side Shelves To Cart
H015	M6 Phillips Head Screw	2	Install Tool Holder To Side Shelf
H008	M6 Nut	2	
H013	M18x1.5 Nut	1	Install Pressure Cylinder To Holder
H014	M8x1.25 Nut	1	Install Tank Hook To Pressure Cylinder
P8080A	AA Battery	1	Install To Electric Ignitor

Actual Size and Quantity of Each Hardware Piece:



3/8" Wheel Bolt
Qty. 2
Ref. # H001

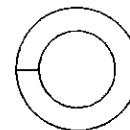

Spring Washer
Qty. 2
Ref. # H002

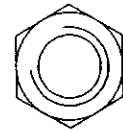

3/8" Nut
Qty. 2
Ref. # H003



1/4"x3/4" Phillips
Head Screw
Qty. 8
Ref. # H004

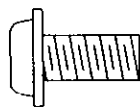

1/4"x1/2" Phillips
Head Screw
Qty. 20
Ref. # H005

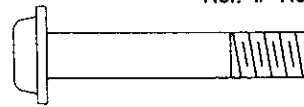

1/4"x1-3/8" Phillips Head Screw
Qty. 4
Ref. # H012



1/4" Lock Nut
Qty. 4
Ref. # H009



AA Battery
Qty. 1
Part # P8080A

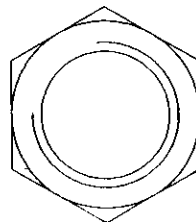

M18x1.5 Nut Qty. 1
Ref. #
H013(attached to
Pressure Cylinder)



M8x1.25 Nut Qty. 1
Ref. # H014(attached
to Pressure Cylinder)

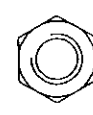

M6 Nut
Qty. 2
Ref. # H008(packed
with Tool Holder)

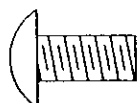

M6 Phillips Head Screw
Qty. 2
Ref. # H015(packed with Tool Holder)

Parts Diagram

Remove all components from the packing carton and place within easy reach. Do not throw the shipping carton away; instead use it as an elevated assembly surface.

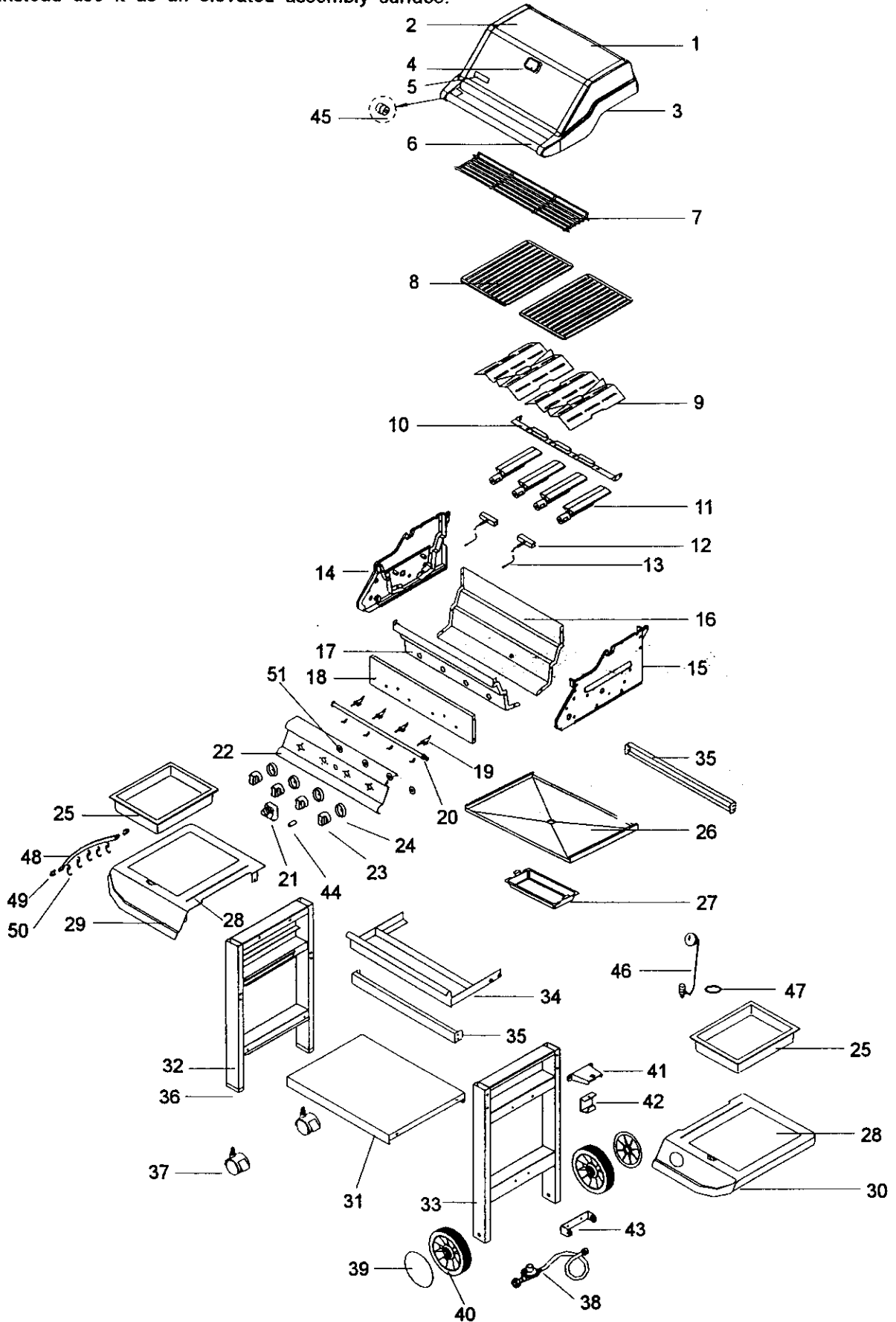

Parts List

REF#	DESCRIPTION	PART#	QTY
1.	Lid - Stainless Steel	P0149F	1
2.	Lid Side Panel - Left	P0145B	1
3.	Lid Side Panel - Right	P0144B	1
4.	Temperature Gauge	P0615D	1
5.	Name Plate	P0459A	1
6.	Lid Handle	P0237D	1
7.	Stainless Steel Cooking Rack	P1521B	1
8.	Cast Iron Cooking Grid	P1648B	2
9.	Stainless Steel Flame Tamer	P1733A	2
10.	Burner Support Bracket	P2218B	1
11.	Burner Assembly	P1935A	4
12.	Gas Collector Box w/ Electrode	P2618A	2
13.	Ignition Wire Set	P2622A	1
14.	Bowl Panel - Left	P0751A	1
15.	Bowl Panel - Right	P0752A	1
16.	Bowl Panel - Rear	P0732B	1
17.	Bowl Panel - Front	P0731B	1
18.	Heat Shield	P2968A	1
19.	Gas Valve Assembly	P32C1A	4
20.	Gas Manifold	P5028A	1
21.	Electric Ignitor	P2503D	1
22.	Control Panel	P2957A	1
23.	Control Knob	P3430A	4
24.	Control Knob Seat	P3430C	4
25.	Storage Bin	P1134A	2
26.	Grease Draining Tray	P2736A	1
27.	Grease Receptacle	P2717C	1
28.	Insert Plate - Stainless Steel	P1131B	2
29.	Side Shelf - Left	P1131E	1
30.	Side Shelf - Right	P1132C	1
31.	Bottom Shelf	P1048B	1
32.	Cart Legs - Castor Side	P0937A	1
33.	Cart Legs - Wheel Side	P0840A	1
34.	Drawer	P8078B	1
35.	Brace	P4213A	2
36.	Castor Seat	P4521A	2
37.	Castor	P5109A	2
38.	Regulator and Hose	P3632E	1
39.	Wheel Hub Cap - Graphite	P5113C	2
40.	Wheel - Graphite	P5106D	2
41.	Pressure Cylinder Holder	P4033C	1
42.	Tank Hook	P4033A	1
43.	Tank Guide	P4033B	1
44.	AA Battery	P8080A	1
45.	Heat-Insulating Spacer	P5573A	2
46.	Fuel Gauge Assembly	P80F9B	1
47.	Fixing Ring	P80F9C	1
48.	Tool Holder	P55B6B	1
49.	Screw Cover	P55B6C	2
50.	Tool Hook	P55B6D	5
51.	Rain Shield	P80D5A	4
---	Owner's Manual	P4795A	1
---	Hardware Pack (contents page 5)	P55D9A	1

If there are damaged or missing parts when you unpack this unit from the shipping box, or you have questions about assembly, call us 8am - 8pm CST, Monday through Friday
1-888-317-7642

For the repair or replacement parts you need:
 Call 6 am - 11 pm CST, 7 days a week
1-800-366-PART

To make sure you obtain the correct replacement parts for your Kenmore Elite gas grill, please refer to the part numbers on this page. The following information is required to assure you receive the correct parts:

1. Grill Model Number (see CSA label on grill)
2. Part Number
3. Part Description
4. Quantity of parts needed

Important: Keep this Owner's Manual for convenient referral and for part replacement.

Important: Use only Sears authorized parts. The use of any part that is not Sears authorized can be dangerous and will also void your product warranty.

Assembly Instructions

Before assembling your gas grill, use the parts list to check that all necessary parts have been included. Inspect grill and cart parts for damage as you proceed. Do not assemble or operate your grill if it appears damaged. If you have questions during the assembly process, call 8am - 8pm CST, Monday through Friday, 1-888-317-7642

Remove the white PVC protective film from stainless steel surfaces before assembly.

CAUTION:

While it is possible for one person to assemble this gas grill, obtain assistance from another person when handling some of the larger, heavier pieces, especially the grill head.

Remove all cart parts, hardware, and grill head from carton. Assemble the gas grill on a protective work surface, such as the shipping box, to avoid scratching grill surfaces. Refer to parts list and hardware pack illustrations to help you assemble your grill.

Assembling The Grill Cart

1. Install the Cart Legs-Castor Side to either side of the Bottom Shelf. Make sure the Drawer Channel faces inwards. Secure using 2 of the 1/4"x1/2" Phillips head screws provided. Install the Cart Legs-Wheel Side to the other side of Bottom Shelf by using the same-sized screws. See Fig. 1.
2. Screw the 2 Castors into Castor Seats (see bottom of Cart Legs-Castor Side). Turn the threaded castor stem by hand, clockwise until it stops. Tighten with an Open-end 11/16" wrench. See Fig. 2.
3. Install the 2 Wheels to the Cart Legs-Wheel Side, by inserting the wheel bolt through the wheel and axle hole on the cart leg as shown in Fig. 2. Put spring washer and 3/8" nut onto bolt and tighten securely using a size 4 phillips screwdriver. Do not overtighten or wheel will not turn freely. Snap Wheel Hubs onto the wheels.
4. Install the 2 Braces between Cart Legs-Castor Side and Cart Legs-Wheel Side. Align the holes on the ends of Brace with the tapped holes on Cart Legs. Secure firmly using 4 of the 1/4"x1/2" Phillips head screws for each Brace. See Fig. 3.

Figure 1

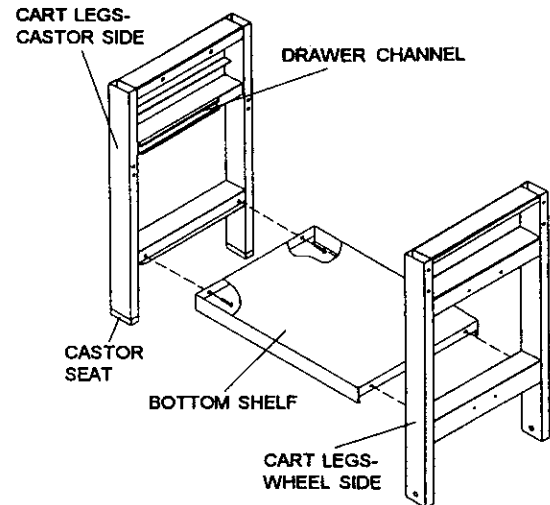

Figure 2

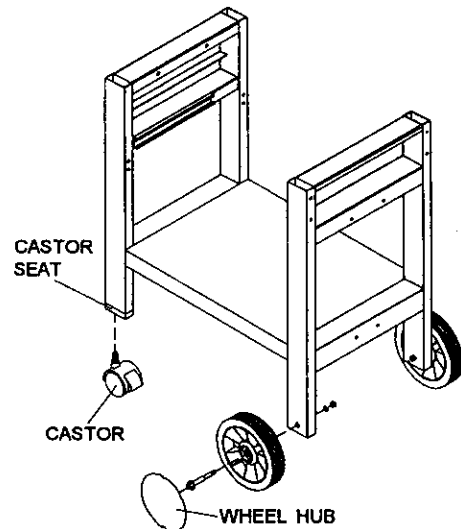
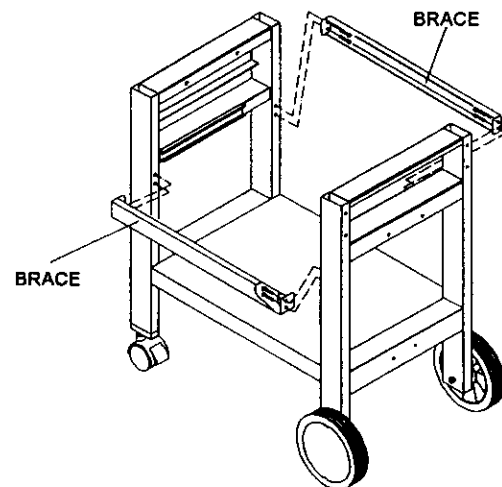

Figure 3



Assembling The Tank Guide and Grill Drawer

1. Attach the Pressure Cylinder Holder and Tank Guide to the Cart Legs-Wheel Side as shown in Fig. 4a. Align the holes of both parts with the tapped holes on Cart Legs-Wheel Side. Secure firmly using 4 of the 1/4"x1/2" Phillips head screws provided.
2. Install a 1/4"x1/2" Phillips head screw to the rear of each Drawer Track. Without these screws the drawer will not stop properly.
3. Slide the Drawer into the Drawer Tracks until it stops. See Fig. 4b.
4. Install a 1/4"x1/2" Phillips head screw to the front of each Drawer Track. This important step prevents the drawer from being pulled outside the tracks. See Fig. 4b.

Installing The Grill Head

1. Now that you've assembled the grill cart you can install the pre-assembled Grill Head. See Fig. 5. To reduce the weight of the Grill Head, we suggest you open the Grill Lid and remove the packed components. Even with the components removed, this step requires 2 people to lift and position the Grill Head onto the grill cart. Be sure to align the 2 holes beneath the hang ledge on each side of the Grill Head with the 2 holes on each cross brace of cart. Raise Grill Lid and insert 4 of the 1/4"x1-3/8" Phillips head screws and lock nuts and tighten securely.
2. From the back side of grill head, install the Grease Draining Tray. See Fig. 5.
3. Center the Grease Receptacle under Grease Draining Tray. See Fig. 5.

Figure 4a

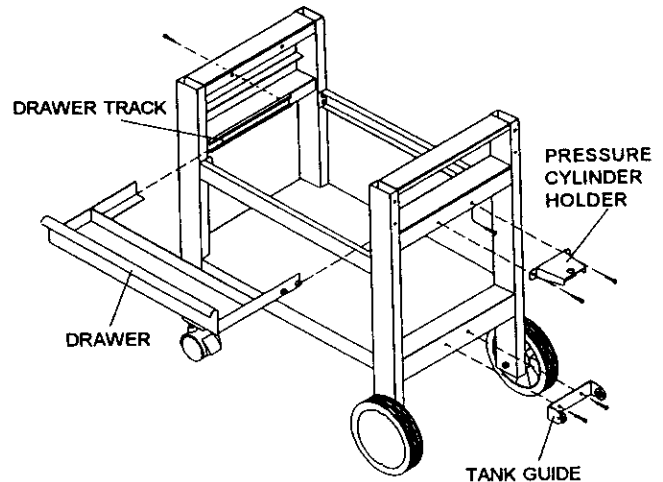

Figure 4b

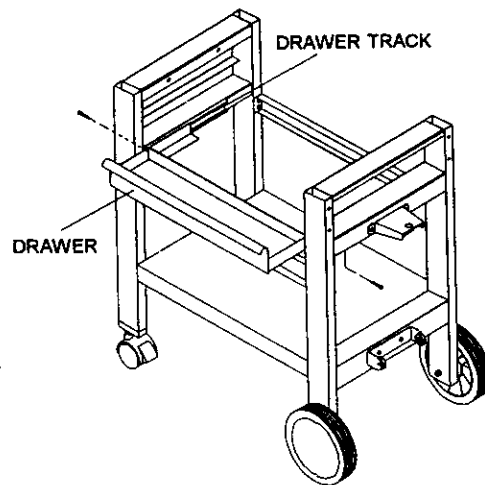
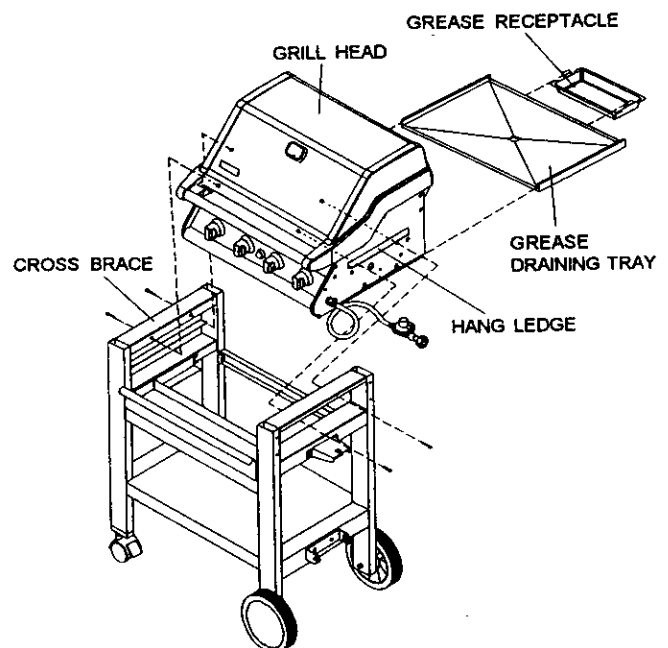

Figure 5



Installing Side Shelves and Tool Holder

1. Remove and discard the protective rubber boots from the Side Shelf braces.
2. Attach Side Shelves to Cart Legs as shown in Fig. 6a. Align the 4 holes on each Side Shelf frame with the holes on the Cart Legs. Tighten securely using 4 of the 1/4"x3/4" Phillips head screws provided.
3. Install and slide the 5 Tool Hooks onto the Tool Holder from the narrow section. For safety's sake, the Tool Hooks face in the same direction as both ends of Tool Holder. See Fig. 6b.
4. Attach the Tool Holder to the left Side Shelf. Align the holes on Tool Holder with the holes on the left side of Side Shelf. Secure firmly using 2 of the M6 Phillips head screws and M6 nuts packed with the Tool Holder.
5. Slide the 2 screw covers onto both ends of Tool Holder. See Fig. 6b.

Installing Fuel Gauge Assembly

1. Unscrew the M18x1.5 and M8x1.25 nuts from the Pressure Cylinder. See Fig. 7a.
2. Unscrew and remove the Fixing Ring from the Dial. See Fig. 7a.
3. Insert the end with Pressure Cylinder through the notched hole on right Side Shelf. See Fig. 7b. Turn the Dial until it matches the notched hole, and push it into the hole.
4. Screw the Fixing Ring back to the Dial from the Pressure Cylinder side. See Fig. 7c.
5. Insert the Pressure Cylinder into Pressure Cylinder Holder, and secure using the detached M18x1.5 nut. See Fig. 8.
6. Attach Tank Hook to the lower thread of Pressure Cylinder, and secure firmly using the detached M8x1.25 nut. Once tank is connected, the dial will indicate amount of gas in tank.

Figure 8

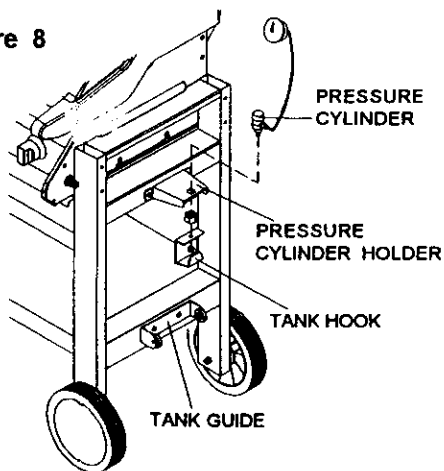

Figure 6a

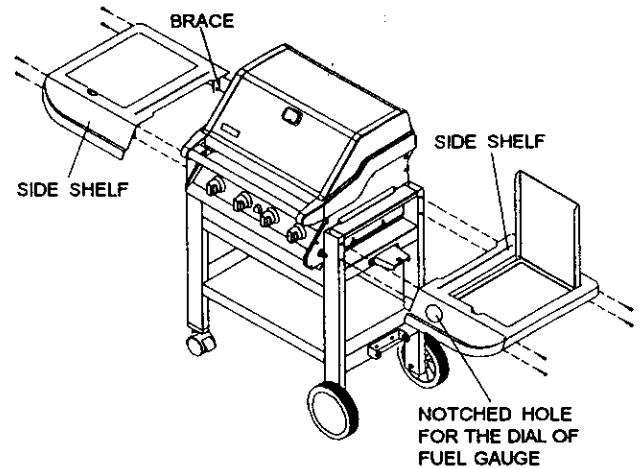

Figure 6b

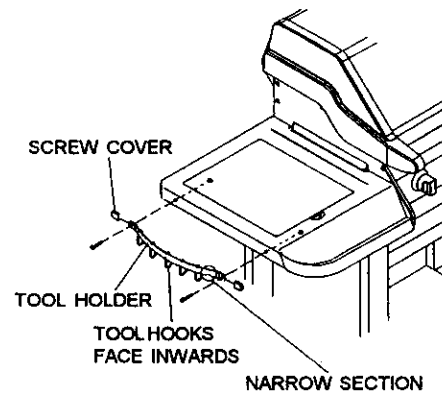

Figure 7a

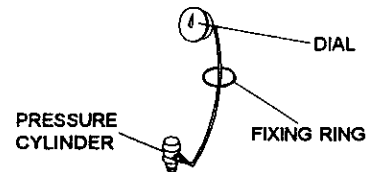

Figure 7b

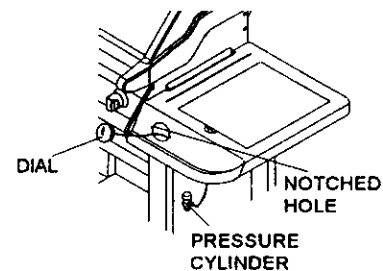
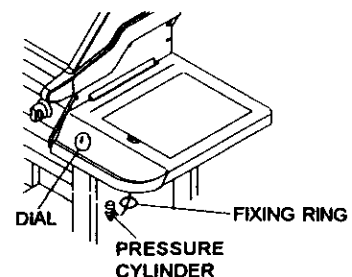

Figure 7c



Installing Storage Bins

1. Place a Storage Bin into each Side Shelf. See Fig. 9.

Ignitor Battery Installation - See Fig. 10

1. Unscrew the Ignitor Cap located on the grill Control Panel and remove the Contact and Spring from the Ignitor Slot.
2. Place the manufacturer supplied AA battery into the Ignitor Slot. Be sure to place the positive pole facing toward you.
3. Place the Spring over the AA battery, then place the Contact on top of the Spring. Screw the Ignitor Cap back onto the grill Control Panel.

Electrode Check - Requires an Assistant

Before placing the cooking components into your grill, ensure that the Spark Electrode Tip is properly positioned within each Gas Collector Box (a 3-1/4" wide stainless mechanism found at the front between each set of burners.) The easiest way to ensure this is to perform the following Electrode Check:

1. Be sure all Control Knobs are set to OFF. Open the Grill Lid.
2. Have an assistant stand behind to the right of the grill and look down at each Gas Collector Box. NEVER put your face inside the Grill Head.
3. Press the Ignitor Cap and have the assistant watch for a small blue spark within each Gas Collector Box. If a spark is present the Electrode Tips are properly positioned.
4. If no spark is seen the Spark Gap shown in Fig. 11 needs to be adjusted as follows:
 - Using an adjustable wrench, loosen the Inside Nut just until the Gas Collector Box can be maneuvered and turned upward.
 - The gap between the Spark Electrode Tip and the Spark Receiver should be approximately 3/16".
 - If the gap is wider than 3/16" use a pair of long nose pliers and gently squeeze the Gas Collector Box until the gap is correct.
 - Return the Gas Collector Box to its original horizontal position, secure the Inside Nut and try the Electrode Check again.

Figure 9

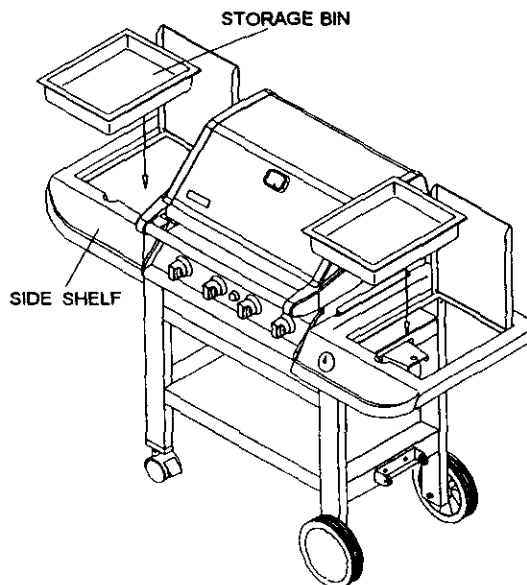

Figure 10

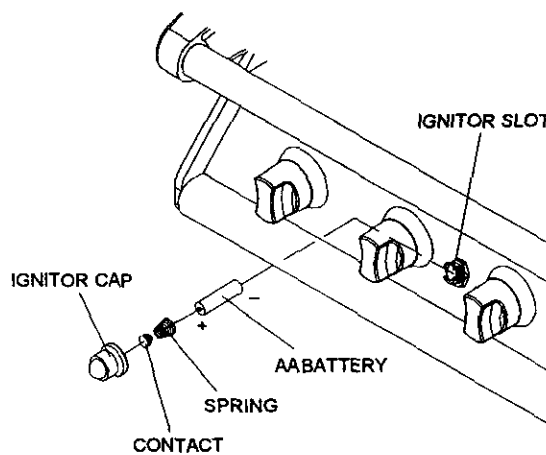
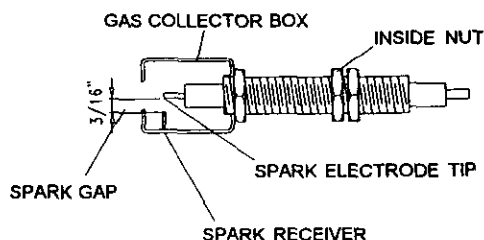

Figure 11 - Side View



Installing Cooking Components

Important: Before cooking on your grill the first time, wash the cooking grids and warming rack with warm, soapy water. Rinse and dry thoroughly. Season with cooking oil regularly. After cooking is completed, turn grill to HIGH setting for about five minutes to burn off excess grease or food residue.

1. Place the 2 Stainless Steel Flame Tamers on the lower ledge above burners. See Fig. 12. They should meet in the center.
2. Evenly space the reversible Cast Iron Cooking Grids on the ledge above the Stainless Steel Flame Tamers.
3. Place the Secondary Cooking Rack into the slots on the upper left and upper right of grill bowl panels.

Connecting A Liquid Propane Gas (LP gas) Tank To Your Grill

1. Hang your filled gas tank on the Tank Hook. The lower section of the gas tank will lean on the Tank Guide. See Fig. 13. Make sure the LP gas tank valve is in the full OFF position. (Turn clockwise to close.)
2. Check the tank valve to ensure it has proper external mating threads to fit the hose & regulator assembly provided. (Type 1 connection per ANSI Z21.58a-1998)
3. Make sure all burner valves are in the OFF position.
4. Inspect the valve connection port and regulator assembly. Look for any damage or debris. Remove any debris. Inspect hose for damage. Never attempt to use damaged or plugged equipment.
5. When connecting the hose and regulator assembly to the tank valve, hand tighten nut clockwise to a full stop. Do Not use a wrench to tighten because it could damage the Quick Coupling Nut and result in a hazardous condition.
6. Open the tank valve fully (counterclockwise). Use a soapy water solution to check all connections for leaks before attempting to light your grill. See "Checking for LP Gas Leaks" on page 13. If a leak is found, turn the tank valve off and do not use your grill until the leak is repaired.

Disconnecting A Liquid Propane Gas (LP gas) Tank From Your Grill

1. Turn the burner valves and LP gas tank valve to the full OFF position. (Turn clockwise to close.)
2. Detach the hose and regulator assembly from the LP gas tank valve by turning the Quick Coupling Nut counterclockwise.

Figure 12

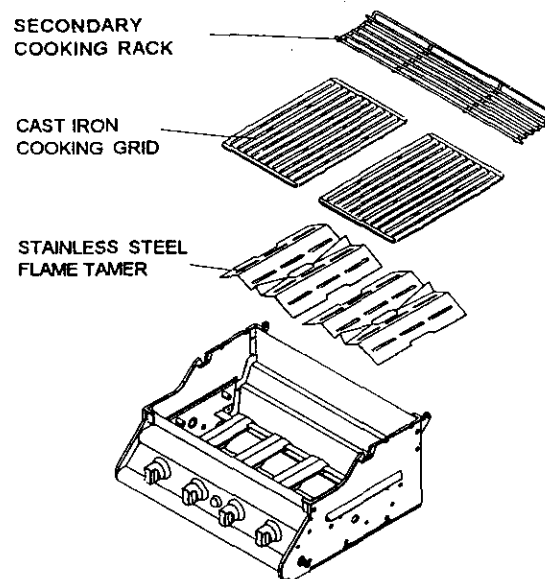
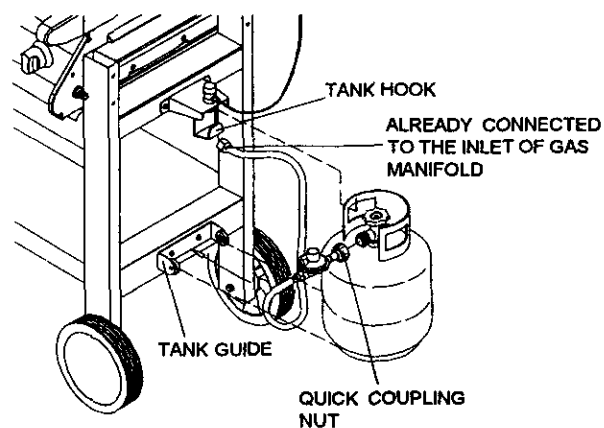

Figure 13



CAUTION: When the appliance is not in use, the gas must be turned off at the supply tank.

Congratulations

Your Kenmore Elite gas grill is now ready for use. Before the first use and at the beginning of each season (and whenever the LP gas tank has been changed):

1. Read all safety, lighting and operating instructions.
2. Check gas valve orifices, burner tubes and burner ports for any obstructions.
3. Perform gas leak check according to instructions found on page 13 of this manual.

⚠ WARNING

A strong gas smell, or the hissing sound of gas indicates a serious problem with your gas grill or the LP gas tank. Failure to immediately follow the steps listed below could result in a fire or explosion that could cause serious bodily injury, death, or property damage.

- Shut off gas supply to the gas grill.
- Turn the control knobs to OFF position.
- Put out any flame with a fire extinguisher.
- Open grill lid.
- Get away from the LP gas tank.
- Do not try to fix the problem yourself.
- If odor continues or you have a fire you cannot extinguish, call your fire department. Do not call near the LP gas tank because your telephone is an electrical device and could create a spark resulting in fire and/or explosion.

Checking For LP Gas Leaks

Never test for leaks with a flame. Prior to first use, at the beginning of each season, or every time your LP gas tank is changed, you must check for gas leaks. Follow these four steps:

1. Make a soap solution by mixing one part liquid detergent and one part water.
2. Turn the grill control knobs to the full OFF position, then turn the gas ON at source.
3. Apply the soap solution to all gas connections. If bubbles appear in the soap solution the connections are not properly sealed. Check each fitting and tighten or repair as necessary.
4. If you have a gas leak that you cannot repair, turn off the gas at the source, disconnect fuel line from your grill and call 1-800-4-MY-HOME or your gas supplier for repair assistance.

Lighting Instructions

Basic Lighting Procedures

1. Familiarize yourself with the safety guidelines at the front of this manual. Do not smoke while lighting grill or checking gas supply connections.
2. Be sure the LP gas tank is filled.
3. Check that the end of each burner tube is properly located over each valve orifice.
4. Make sure all gas connections are securely tightened.
5. Open the grill lid.

⚠ WARNING

Failure to open the grill lid during the lighting procedures could result in a fire or explosion that could cause serious bodily injury, death, or property damage.

6. Set control knobs to OFF and open the LP gas tank valve slowly until 1/4 to 1/2 open.
7. Push and turn the LEFT control knob to HIGH.
8. Immediately press the electric ignitor for 3-4 seconds to light the burner.
9. If the burner does not light, turn the control knob to OFF, wait 5 minutes for gas to clear, then retry.
10. Once the first grill burner is ignited, the adjacent burner can be lit by simply turning its control knob to HIGH.
11. Adjust control knobs to your desired cooking temperature.

Lighting Your Grill by Match

To light your gas grill by match, follow steps 1 through 6 of the Basic Lighting Procedures. Then, insert a lit match through the lighting hole on either side of the grill. See Fig. 14. Turn the nearest control knob to the HIGH setting to release gas. The burner should light immediately.

Figure 14

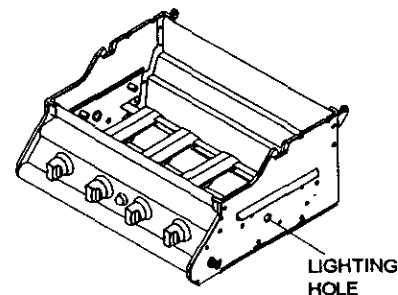

⚠ WARNING

Never lean over the grill cooking area while lighting your gas grill. Keep your face and body a safe distance (at least 18 inches) from the lighting hole or burners, when lighting your grill by match.

If the grill fails to light properly:

1. Turn gas off at source and turn the control knob to OFF. Wait at least five minutes for gas to clear, then retry.
2. Check gas supply and connections.
3. Repeat lighting procedure. If your grill still fails to operate properly, turn the gas off at source, turn the control knobs to OFF, then check the following:
 - Misalignment of burnertubes over orifices
Correction: Reposition burnertubes over orifices.
 - Obstruction in gas line
Correction: Remove fuel line from grill. Do not smoke! Open gas supply for one second to clear any obstruction from fuel line. Close off gas supply at source and reconnect fuel line to grill.
 - Plugged orifice
Correction: Remove burners from grill by pulling cotter pin (beneath burner) using a screwdriver or pliers. Carefully lift each burner up and away from gas valve orifice. Remove the orifice from gas valve and gently clear any obstruction with a fine wire. Then reinstall all orifices, burners, cotter pins and cooking components.

If an obstruction is suspected in gas valves or gas valve bracket, please call for repair service at 1-800-4-MY-HOME.
 - Misalignment of ignitor on burner
Correction: Check for proper position of the electrode tip as shown in Figure 11. The gap between the Spark Electrode Tip and Spark Receiver should be approximately 3/16". Adjust if necessary. With the gas supply closed and all control knobs set to OFF press the electric ignitor cap and check for the presence of a spark at the electrode.
 - Disconnected Ignition Wires
Correction: Inspect the Ignitor junction box found behind the Control Panel. Connect loose Ignitor wires to junction box and try to light the grill.
 - Weak AA battery
Correction: Unscrew the Ignitor Cap and replace the battery.

4. If the grill still does not light you may need to purge air from the gas line or reset the regulator excess gas flow device. **Note:** This procedure should be done every time a new LP gas tank is connected to your grill.

To purge air from your gas line and/or reset the regulator excess gas flow device:

- Turn the control knobs to the OFF position.
 - Turn off the gas at the tank valve.
 - Disconnect regulator from LP gas tank.
 - Let unit stand for 5 minutes.
 - Reconnect regulator to the LP gas tank.
 - Turn the tank valve on slowly until 1/4 to 1/2 open.
 - Open the Grill Lid or Side Burner Lid.
 - Set control knobs to OFF and open the LP gas tank valve.
 - To light grill push and turn the LEFT control knob to HIGH.
5. If all checks or corrections have been made and you still have questions about operating your gas grill, call the Manufacturer's Customer Service Helpline 8am - 8pm CST, Monday through Friday at 1-888-317-7642.

 **WARNING**

Should a "FLASH-BACK" fire occur in/or around the burner tubes, follow the instructions below. Failure to comply with these instructions could result in a fire or explosion that could cause serious bodily injury, death, or property damage.

- Shut off gas supply to the gas grill.
- Turn the control knobs to OFF position.
- Put out any flame with a fire extinguisher.
- Open grill lid.
- Once the grill has cooled down, clean the burner tubes and burners according to the cleaning instructions found on page 16 in this manual.

Cleaning and Maintenance

As with all appliances, proper care and maintenance will keep your grill in top operating condition and prolong its life. By following these cleaning procedures on a timely basis, your grill will stay clean and work properly with minimum effort.

CAUTION:

Be sure your grill is OFF and cool before cleaning. Take care not to chip or scratch the painted surfaces because it will void your warranty against rusting.

Cleaning The Cooking Grids

Before initial use and periodically we suggest you wash your cooking grids in a mild soap and warm water solution. You can use a wash cloth or brass brush to clean your cooking grids.

CAUTION:

Take care not to chip or scratch the porcelain finish because it will void your warranty against rusting. Never try to clean your cooking grids unless you are sure the grids are cool to the touch.

Cleaning The Flame Tamers

Periodically you should wash the Flame Tamers in a soap and warm water solution. Use a brass brush to remove stubborn burnt-on cooking residue. Dry the Flame Tamers thoroughly before you reinstall them into the cooking bowl.

Cleaning The Grease Tray and Receptacle

To reduce the chance of fire, the Grease Draining Tray and Grease Receptacle should be visually inspected before each grill use. Remove any grease and wash grease tray and receptacle with a mild soap and warm water solution.

Annual Cleaning of The Grill Interior

Burning-off the grill after every cookout will keep it ready for instant use. However, once a year you should give the entire grill a thorough cleaning to keep it in top operating condition. Follow these steps:

1. Turn all burner valves to the full OFF position.
2. Turn the LP gas tank valve to the full OFF position.
3. Detach the LP gas regulator assembly from your gas grill.
4. Remove and clean the flame tamers, cooking grids and grill burners.
5. Cover each gas valve orifice with aluminum foil.
6. Brush the inside and bottom of the grill with a stiff brass brush, and wash with a mild soap and warm water solution. Rinse thoroughly and let dry.
7. Remove aluminum foil from orifices and check each orifice for obstruction.

8. Check each spark electrode, adjusting as needed. The space between the Spark Electrode Tip and Spark Receiver should be approximately 3/16".
9. Replace the burners and adjust the gas collector box. The edge of the collector box should be overlapping the burner port.
10. Replace flame tamers and the cooking grids.
11. Reconnect the gas source and observe the burner flame for correct operation.

Cleaning Exterior Surfaces:

Before initial use, and periodically thereafter, we suggest you wash your grill using a mild soap and warm water solution. You can use a wash cloth or sponge for this process. Do not use a stiff wire or brass brush that might remove paint during the cleaning process.

Cleaning Exterior Stainless Steel Surfaces:

Weathering and extreme heat can cause exterior stainless steel surfaces to turn tan in color. Use a foam or cream Stainless Steel Cleaner to polish the stainless steel surfaces of your grill. Never use abrasive cleaners or scrubbers because they will scratch and damage your grill. Follow these steps for the best results.

1. Turn the LP gas tank valve (clockwise) to the full OFF position. Disconnect the regulator and hose assembly from LP gas tank. Cover exposed gas fitting with aluminum foil.
2. Remove dirt or grease using a soft cloth and polish stainless surfaces. Wipe with a soft cloth.
3. Remove aluminum foil from exposed gas fitting and allow grill to air dry before attaching the regulator and hose to your LP gas tank.

Cleaning The Burner Tubes and Burner Ports

To reduce the chance of "FLASH-BACK" the procedure below should be followed at least once a month in late summer or early fall when spiders are most active or when your grill has not been used for a period of time.

1. Turn all burner valves to the full OFF position.
2. Turn the LP gas tank valve (clockwise) to the full OFF position.
3. Detach the regulator assembly from the LP gas tank by turning the Quick Coupling Nut counter-clockwise.
4. Remove the cooking grids, flame tamers, and grease trays from your grill.
5. Remove the cotter pin from the rear underside of each burner using a pair of long nose pliers.
6. Carefully lift each burner up and away from the gas valve orifice.
7. Refer to Fig. 1 and perform one of these three cleaning methods:
 - Bend a stiff wire, (a lightweight coat hanger works well) into a small hook as shown below. Run the hook through the burner tube and inside the burner several times to remove any debris.
 - Use a bottle brush with a flexible handle. Run the brush through the burner tube and inside the burner several times, removing any debris.
 - Use an air hose to force air through each burner tube. The forced air should pass debris or obstructions through the burner and out the ports.



Figure 1

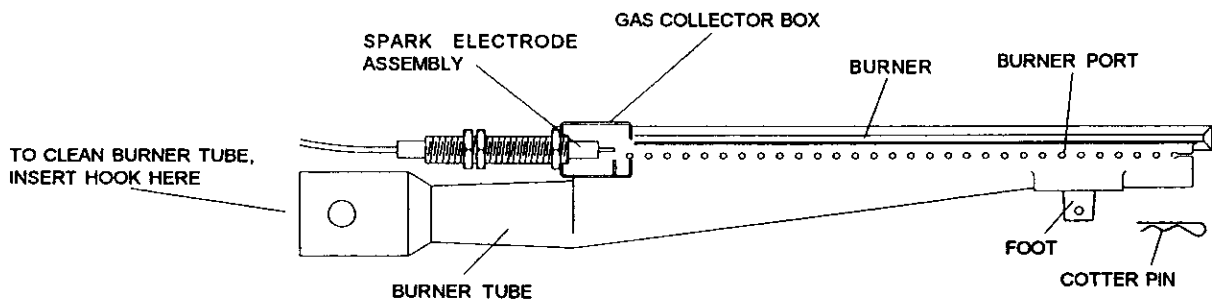

Regardless of which burner cleaning procedure you use, we recommend you also complete the following steps to help prolong burner life.

1. Use a wire brush to clean the entire outer surface of each burner until free of food residue and dirt.
2. Clean any clogged ports with a stiff wire, such as an open paper clip.
3. Inspect each burner for damage (cracks or holes) and if such damage is found, order and install a new burner. After installation, check to insure that the gas valve orifices are correctly placed inside the ends of the burner tubes. Also check the position of your spark electrode.

WARNING

The location of the burner tube with respect to the orifice is vital for safe operation. Check to ensure the orifice is inside of the burner tube before using your gas grill. See Fig. 2. If the burner tube does not fit over the valve orifice, lighting the burner may cause explosion and/or fire.

Figure 2

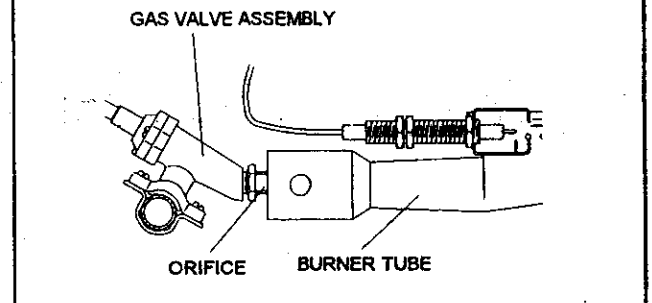

Frequently Asked Questions

Question: Who do I call with questions about grill assembly or if parts are damaged or missing from my shipping box?

Answer: Call the Manufacturer's Customer Service Helpline 8am - 8pm CST, Monday through Friday, at 1-888-317-7642.

Question: Can I convert my Kenmore Elite gas grill from one fuel type to another?

Answer: This Kenmore Elite gas grill is manufactured to exact specifications and is approved by the Canadian Standards Association (CSA) for LP gas use only. For your own safety, conversion kits are not available and any attempt to convert your grill from LP gas to Natural Gas will void your product warranty.

Question: Are the serial and model numbers of my grill listed somewhere for future reference?

Answer: Yes, this valuable information is listed on a silver label found on the right side of your Grill Head under the side shelf.

Question: Why doesn't the hose and regulator assembly supplied with my new Kenmore Elite grill fit the older LP gas tank I've used for years?

Answer: The U.S. Government regulates gas appliances and LP gas tanks. Whenever new regulations are passed the LP gas tank fittings are altered. If your current tank does not fit the hose and regulator supplied with your new grill, the tank is outdated and must be replaced.

Question: What can cause grill parts to rust and what affect does it have on the grill materials.

Answer: Rusting is a natural oxidation process and may appear on cast-iron burners, cooking grids and steel cart parts. Because your grill is manufactured with heavy gauge steel, rust will not affect the short term performance of your grill or affect the taste of your foods. The manufacturer can not warranty against rust unless the components are completely rusted through.

To protect against the natural rusting process, your cooking grids have a porcelain finish. However, dropping, scraping or scratching these items will damage the porcelain finish and allow rusting. To minimize rusting we recommend you "season" the cooking grids regularly—before and after each use. Consistent seasoning will help cast-iron resist rusting and will create a non-stick cooking surface.

Question: How do I season cast-iron?

Answer: Before and after each cookout, apply a thin layer of cooking oil, spray or vegetable shortening to each cooking grid and/or optional cast iron cooking accessories. Be sure to coat the entire surface including edges and any areas with chipped porcelain. Insert the cooking grids into your warm grill for 2 to 3 minutes.

Question: What is the best way to protect my new Kenmore Elite gas grill from the weather?

Answer: A good quality grill cover should be used to protect your grill when not in use. Also, follow the cleaning and maintenance instructions in this owner's manual on a timely basis, and your new grill will give you years of enjoyment.

Question: Sometimes my grill does not light when I push the ignitor button. Why?

Answer: Refer to the Lighting Instructions in this owner's manual. Also check these common causes.

- Ignitor AA battery may need replacing.
- Ignitor wires may be loose. Remove the AA battery, inspect the Ignitor junction box found behind the Control Panel, and connect any loose wires.

Question: Where can I buy replacement parts?

Answer: For the repair or replacement parts you need call 6 am - 11 pm CST, 7 days a week 1-800-366-PART (1-800-366-7278). Use only Sears authorized parts. The use of any part that is not Sears authorized can be dangerous and will also void your product warranty.

Question: Sometimes I hear a humming sound coming from my regulator. What causes this?

Answer: The humming noise is actually the gas flowing through the regulator. A low volume of noise is perfectly normal and will not interfere with the operations of the grill. If humming noise is loud and excessive you may need to purge air from the gas line or reset the regulator excess gas flow device. **Note:** This procedure should be done every time a new LP gas tank is connected to your grill. For help with this procedure refer to page 14, step 4, or call the Manufacturer's Customer Service Helpline, 8am - 8pm CST, Monday through Friday at 1-888-317-7642.

Cooking Instructions

WARNING

Your grill will get very hot. Never lean over the cooking area while using your grill. Do not touch cooking surfaces, grill housing, grill lid or any other grill parts while the grill is in operation, or until the grill has cooled down after use.

Failure to comply with these instructions may result in serious bodily injury.

Burn-off

Before cooking on your gas grill for the first time, you will want to "burn off" the grill to eliminate any odor or foreign matter. Just ignite the burners, close the lid, and operate grill on the HIGH setting for three to five minutes.

CAUTION:

Operating your grill on the HIGH setting for longer than five minutes may damage certain parts of your grill. **Do not leave your grill unattended.**

Preheating

To preheat, light your grill on HIGH, close the lid and follow this timetable:

- For high temperature cooking, preheat grill 3 to 5 minutes.
- For low temperature cooking, preheat grill 3 minutes.
- To slow cook, preheating is not necessary.

Cooking Temperatures

High setting: Only use this setting for fast warm-up, searing steaks or chops and for burning food residue off the grill after cooking is complete. **Never use the HIGH setting for extended cooking.**

Medium to Low settings: Most recipes specify medium to low settings, including all smoking, rotisserie cooking and for cooking lean cuts such as fish.

NOTE: Temperature settings will vary with the amount of wind and temperature outside your home.

Direct Cooking

The direct cooking method can be used with the supplied cooking grids, optional griddle or cooking pan placed directly over the lit grill burners. **Direct cooking requires the grill lid to be open.** This method is ideal for searing and whenever you want meat, poultry or fish to have an open-flame barbecued taste. Deep frying and smoking are also best cooked in this manner because they require direct heat.

Indirect Cooking

The indirect cooking method can also be used with the supplied cooking grids, optional griddle, or cooking pan. To cook **indirectly**, the food should be placed on the left or right side of your grill with the burner lit on the opposite side. Or place your food on the secondary cooking rack mounted inside your grill bowl and light the outer grill burners. Either way, **indirect cooking must be done with the lid down.**

Seasoning Cooking Grids and Cast-Iron

Before and after each cookout, apply a thin layer of cooking oil, spray or vegetable shortening to each cooking grid and/or optional cast iron cooking accessories. Be sure to coat the entire surface including edges and any areas with chipped porcelain. Insert the cooking grids into your warm grill for 2 to 3 minutes.

Flare-Ups

The fats and juices dripping from grilled food can cause flare-ups. Since flare-ups impart a favorably distinctive taste and color to food cooked over an open flame, they should be accepted up to a point. Nevertheless, uncontrolled flaring can result in a ruined meal.

WARNING

Do not line the bottom of the grill housing with aluminum foil, sand or any substance that will restrict the flow of grease into the grease draining tray and receptacle.

Failure to comply with these instructions could result in a fire or explosion that could cause serious bodily injury, death, or property damage.

CONGRATULATIONS

Your Kenmore Elite gas grill is **now ready to grill.** Remember to keep the lid open when cooking directly on the grill. For most foods it's best to start grilling on high. Once the food is seared, reduce the heat to medium. Foods marinated with ingredients such as honey may burn because of the high sugar content. You should begin their cooking on medium. A favorite on the grill is sausages. Always cook them slowly and if they're particularly fatty, it may be best to partially boil them first.

Guide to Grilling Meat and Poultry with the Direct Cooking Method

Grilling Steak and Ribs

Turn the grill burners on high, close the lid and preheat your grill 3 to 5 minutes. Open lid and place the meat on the cooking grid directly above the lit burners. Cook the meat on both sides until seared. Reduce the heat to medium and cook meat until done. Grilling times will vary according to meat thickness.

Grilling Hamburger and Sausages

Turn the grill burners on high, close lid and preheat your grill 3 to 5 minutes. Open lid and place the meat on the cooking grid directly above the lit burners. Cook the meat on both sides until seared. Reduce the heat to medium and cook the meat until done. Grilling times will vary according to meat thickness.

Grilling Poultry

Turn the grill burners on high, close lid and preheat your grill 2 to 3 minutes. Then raise the lid, reduce heat to medium and cook poultry directly over lit burners until done. Poultry skin is fatty so you should expect some flare-ups when using this direct method.

To minimize flare-ups, try grilling poultry using the indirect method. Place the poultry on one side of the grill with the opposing burners on medium heat, and lower the grill lid. Grilling times will vary based on the size of your poultry.

Grilling Pork

Turn burners on high and preheat your grill 3 to 5 minutes with the lid down. Raise lid, place pork on cooking grid and cook until seared. Reduce heat to medium and cook until done. Grilling times will vary according to meat thickness.

Cut of Meat

T-bone steak
Sirloin steak
Beef spare ribs
Porter house steak
New York strip steak

Hamburgers
Sausages

Chicken breast
(cook with bone down)
Chicken wings
Drumsticks

Whole bird
(cook with breast up)

Pork spare ribs
Chops
Loins
Cutlets

Approximate Cooking Times

Rare: 4-8 minutes
Medium: 10-14 minutes
Well done: 15-20 minutes

Rare: 4-6 minutes
Medium: 8-10 minutes
Well done: 10-15 minutes

Direct method:
approximately 15 minutes

Indirect method:
up to 30 minutes

Indirect method:
approximately 1 hour

Rare: 4-8 minutes
Medium: 10-14 minutes
Well done: 15-20 minutes

Guide to Grilling Fish and Seafood with the Direct Cooking Method

Whole Fish and Whole Fillets

Preheat your grill on HIGH for 2-3 minutes with the lid down. Raise lid and turn burners to medium heat. Place fish (skin down) on grill and cook over direct heat until done. Use cooking time as a guide or until fish is opaque but still moist.

Cut of Meat

Whole fish
Whole fish fillets

Approximate Cooking Times

10 - 12 minutes per pound or until fish is opaque

Smaller Fish Fillets and Cubes

Follow the directions from above, using approximate cooking times shown at right. Place a small piece of aluminum foil on the cooking grids if the fish pieces are small enough to drop between the cooking grids.

Fish fillets
Boneless cubes

4 - 5 minutes each side or until fish is opaque

Guide to Grilling Vegetables and Fruit

Prepare your fruit or vegetables and brush with butter or basting sauce if desired. To cook **indirectly**, the food should be placed on the left or right side of your grill with the burner lit on the opposite side and the grill lid down. Or center your food on the secondary cooking rack and light the outer grill burners. Either way, **indirect cooking must be done with the lid down.**

In some instances, you may want to grill vegetables and fruit **directly** over the heat, using the supplied cooking grids or an optional griddle. Foods that work best with direct heat are relatively soft and require a short cooking time; mushrooms, zucchini, tomatoes and skewered fruit such as apricots, peaches, pineapple, strawberries and kiwis. Remember the **grill lid must remain up when cooking directly.** For very firm vegetables particularly potatoes and yams, we recommend that you partially boil until almost cooked, before placing them on the grill.

Cooking times using the **indirect method** with the hood down will be similar to those for your kitchen oven. However, there are many factors such as outside temperature, wind conditions and location of grill that affect your grill performance so we suggest you watch the grill thermometer and adjust the heat accordingly.

Cooking times for foods prepared with the **direct method** will be much shorter mainly because of the direct heat source and softness of the food. Timing will be comparable to normal pan frying or grilling.

Guide to Slow Roasting and Baking Techniques

An Important Note About Heat Settings

The suggested heat settings shown are approximate. There are many factors such as outside temperature, wind conditions and grill location that affect your grill performance. We offer these cooking times as a convenience, but suggest you watch the grill thermometer and adjust the heat accordingly.

Preparing to Roast

Roasting uses the **indirect cooking** method. Therefore, the food should be placed on the left or right side of your grill with the burner lit on the opposite side. Place your meat inside an optional roasting rack and cooking pan that allows you to collect juices for making gravy. You can also use the supplied cooking grid with an aluminum drip pan underneath. Either way, indirect cooking requires the lid of your grill to be closed.

Preheating your grill is not required for slow cooking methods such as roasting. If you do choose to preheat your grill before roasting, turn the burners on high and close lid for approximately 2-3 minutes.

Type of Food	How Cooked	Approximate Cooking Times
Beef	Rare	18 minutes per pound
	Medium	23 minutes per pound
	Well done	27 minutes per pound
Lamb	Medium	18 minutes per pound
	Well done	23 minutes per pound
Veal		27 minutes per pound
Pork		30-33 minutes per pound
Chicken		20-25 minutes per pound
Duck		25 minutes per pound
Fish		10 minutes per pound
Turkey, under 16 pounds		20-25 per pound + 30 minutes
Turkey, over 16 pounds		18-23 per pound + 15 minutes

BAKING TECHNIQUES

From casseroles and cornbread to delicious deserts like fondue fruit skewers or crumb cake, baking on the grill is as easy as baking in the kitchen.

Preparing to Bake

To bake in your new grill you'll need a baking dish or cast-iron cooking pan, and a pair of insulated cooking mitts. If the cooking pan is cast-iron be sure to season the pan before use.

Preheat your grill 3-5 minutes, then lower heat to achieve the baking temperature desired. Baking uses the

Oven Temperature

Slow	300 - 340 F
Moderate	355 - 390 F
High	410 - 480 F

Food preparation

Trim meat of excess fat. Truss meat and poultry with cooking string to retain shape if desired. Bacon strips can be used to cover the outside surface of lean meat and poultry to help prevent it from drying out. Another method for keeping food moist during roasting is to put water in a cooking pan, then cover with foil. The foil should be removed for the first or the last part of the cooking time to ensure proper browning.

Tips for roasting

Except when roasting with water in the roasting pan, the juices that collect in the pan can be used as the base for a tasty sauce or gravy. Place a cooking pan directly over the heat, add extra butter if needed, then add several spoonfuls of flour to thicken sauce. Finally, add sufficient chicken or beef stock to obtain the desired consistency.

Once the meat is cooked, remove it from your grill and cover with a piece of foil. Allow it to stand for 10-15 minutes which allows the juices to settle. This will make carving easier and ensure a tender juicy roast.

indirect cooking method. Therefore, your cooking pan should be placed on the left or right side of your grill with the burner lit on the opposite side.

Tips for Baking

Prepare your favorite recipe as you would in the kitchen. Foods cooked in the grill for long periods of time should always be covered in aluminum foil to retain moisture. You will need to stir the food several times as it bakes, and add additional liquid if required.

Watch the temperature, and adjust to cook according to your recipe directions.

Recommended Grill Setting

Both outside burners on low
One outside burner on high and the other outside burner on low
Both outside burners on high

Guide to Stir-Frying and Deep-Frying

STIR-FRYING TECHNIQUES

This method of cooking is popular around the world and can be easily accomplished outdoors on your **Kearmore Elite** gas grill. It's a quick and healthful way of preparing a complete meal using meat, poultry or seafood in infinite combinations with other interesting ingredients like vegetables, rice or noodles.

Preparing to Stir-fry

Although it is possible to stir fry in other dishes, the **wok** is your best tool. Its high sides enable the cook to stir food without spillage. Its construction allows you to cook quickly at high temperatures, with instant control of heat which is essential for successful stir frying.

Food preparation

Slice meat and poultry into long thin strips and cube fish fillets. Remove all fat from meat and poultry and cut large vegetables into even slices or cubes.

Marinate foods for extra flavor and tenderness. Marinating times will vary for red meat, fish and or various cuts. Less tender cuts of meat should be marinated longer. Remember to always chill marinating food in the refrigerator prior to cooking.

Stir-fry meats, poultry or fish first. Next, add hard vegetables like carrots. Then continue with softer vegetables like snowpeas and peppers. To ensure even cooking, continually stir and toss the food in the **wok** using a wooden spoon or spatula.

Tips for Stir-frying

Place the **wok** directly over a high heat on your grill or side burner. Add only a small amount of food at a time to ensure fast cooking and also to allow the **wok** to reheat between ingredients.

DEEP-FRYING TECHNIQUES

A wide variety of foods can be deep-fried outdoors on your grill, from potatoes, to seafood and chicken. Deep-frying uses a large portion of oil, preferably saturated. The outdoor location is ideal for deep-frying as smoke, grease and smells reach for the sky of the ceiling of your kitchen.

Preparing to Deep-fry

Deep-fry on your grill using a cooking pan or wok, over direct heat with the grill lid raised.

Fill the cooking pan no more than half full of vegetable or corn oil. Start with low heat, then raise the heat gradually. Check the temperature of the oil carefully with a frying thermometer or test with a cube of bread. The cube of bread should brown in about 30 seconds for most cooking needs. A temperature between 350 and 400 degrees is optimal for preparing the majority of deep-fried foods.

Food Preparation

Foods being deep-fried taste better when coated with either batter or breadcrumbs to add flavor and prevent moisture from escaping.

Tips for Deep-frying

Wear an insulated cooking glove and slowly lower foods into the hot oil using a wire scoop or stainless steel tongs. Add only a small quantity of food to the oil, allow it to cook, then repeat with another small quantity. This ensures the oil doesn't drop in temperature. Once the food is cooked, remove it carefully and drain onto a paper towel. Turn the heat off as soon as you have finished deep-frying and allow the pan to cool. When the oil is cool, remove all remnants of fried foods by straining it through a fine metal sieve. Once the oil is quite cool, store it in a clean bottle for future use.

Guide to Using the Secondary Cooking Rack

Vegetables are generally easy to cook on the grill. The cooking rack makes it convenient because you can still use the main cooking area while the vegetables are suspended above the grids.

Pre-cook hard vegetables by briefly boiling or microwaving them before cooking on the grill. Wrap vegetables in a double thickness of foil to protect them while cooking on the grill. Then, remove the foil if desired, 10-15 minutes before the end of cooking, brush vegetables with butter or oil and finish cooking.

The cooking rack can be used for purposes other than just the obvious. Consider using it for warming French bread, garlic bread, croissants or even bagels. A small whole fish wrapped in foil also cooks well in the cooking rack. Parcels of seafood such as scallops, prawns and sliced fish fillets prepared in a sauce and portioned into small foil wraps cooks well this way, too.

Guide to Rotisserie Cooking and Smoking Techniques

ROTISSERIE TECHNIQUES

Rotisserie cooking produces foods that are moist, flavorful and attractive. Although the rotisserie is most commonly used for cooking meat or poultry, nearly anything can be used if prepared properly.

Balancing the Food

In rotisserie cooking, balancing the food is of utmost importance. The rotisserie must turn evenly or the stopping and starting action will cause the food to cook unevenly and possibly burn the heavier side.

The easiest foods to balance are those of uniform shape and texture. To test if the food is balanced correctly when secured, place the ends of the rotisserie spit loosely in the palms of your hands. If there is no tendency to roll, give the spit a quarter turn. If it is still stable, give it a final quarter turn. It should rest without turning in each of these positions. It can then be attached to your grill.

Food Preparation

When preparing poultry, truss the birds tightly so that wings and drumsticks are close to the body of the bird. The cavity of the bird may be stuffed prior to this if you wish. Pull the neck skin down and, using a small skewer, fix it to the back of the bird. Push the rotisserie spit through lengthwise, catching the bird in the fork of the wishbone. Center the bird and tighten with the holding forks. Test the balance as described above.

A rolled piece of meat requires the rotisserie skewer to be inserted through the center of the length of meat, then secured and balanced.

For meats that contain bones, it is best to secure the rotisserie skewer diagonally through the meaty sections. If protruding bones or wings brown too quickly, cover with pieces of foil.

Tips for Rotisserie Cooking

When rotisserie cooking, the majority of heat will come from an indirect source. In other words, the burners at each end of the grill are lit and the food is placed centrally on the rotisserie, with no direct heat source underneath. To catch any drips from the rotisserie food it will be necessary to remove the cooking grids and then place a drip pan directly under the food. These drippings can be used to make gravies and other sauces to accompany the cooked meats. Place the lid down over the food when you start to cook.

The cooking times on a rotisserie will be approximately the same as for oven cooking.

SMOKING TECHNIQUES

Smoking gives food a distinctive, delicious flavor. This surprisingly quick and versatile cooking method expands the creative chef's menu with endless new and innovative ways to prepare popular barbecue dishes.

Preparing to Smoke

All you need for smoking on your Kenmore Elite gas grill is a cooking pan and roasting rack. First, line the inside of the pan with foil. The smoking agent, either pure wood chips or smoking mix, is sprinkled over the foil. Dried herbs and spices may also be added to produce different flavors. Place the cooking pan directly over the burner. The direct heat will eventually produce smoke and season the food. Elevate your food above the cooking pan with a roasting rack or baking rack.

Tips for Smoking

You can reduce the strength of the smoke flavor by only smoking for half or three quarters of the cooking time, then roast your food until done. The heat required for smoking is normally low to medium.

Foods naturally high in oils lend themselves well to smoking, while drier foods benefit from a marinade. Red meats, poultry, game, fish and seafood can all be smoked easily in your new grill. You can also rub the food with herbs, spices or flavored oils. An enormous array of foods can be smoked in your Kenmore Elite gas grill to produce stunning results with very little effort. Here are a few suggestions:

- **Tuna steaks**, marinated in Asian flavors of sesame oil, soy sauce and sherry.
- **Pork filets**, rubbed with ginger, orange rind and brushed with maple syrup.
- **Mussels**, brushed with lemon rind and chili oil.
- **Lamb cutlets**, marinated in virgin olive oil, lemon, oregano and black pepper. The same marinade can be used for a whole leg or rack of lamb.

Recipes

ONION BURGERS

A honey and mustard sauce glazes the onion slices as they cook alongside these delicious burgers. For optimal sweetness, select Vidalia or Walla Walla onions. **Makes 4 open face burgers.**

Ingredients

- 2 large sweet onions, sliced (12 to 16 ounces)
- 2 tablespoons margarine or melted butter
- 2 teaspoons dry mustard
- 2 teaspoons honey
- 1 pound lean ground beef
- 1/4 teaspoon salt
- 1/8 teaspoon pepper
- 4 slices Texas toast
- 4 lettuce leaves
- 4 tomato slices

Preparing Onions

Place onions in a cooking pan or on a small piece of aluminum foil. Combine melted margarine, mustard and honey, then drizzle over onions. Cover pan with lid or fold up edges of foil and seal with double fold to completely enclose onions leaving space for steam to build. Place pan or foil packet on grill directly over medium heat for 15 minutes with the grill hood up.

Preparing Burgers

While onions are cooking, combine ground beef, salt and pepper in a medium bowl and mix well. Shape mixture into four 3/4 inch burger patties and add to grill, directly over heat. Grill burgers along with onions for about 5 minutes, then turn burgers. Grill for 8 to 10 minutes more or until no pink remains in meat, and onions are tender. To serve, toast both sides of Texas toast on grill. Then top each slice of Texas toast with a burger, lettuce, tomato and onion. Sprinkle with pepper if desired.

DOUBLE SALSA BURGERS

A fresh tomato salsa flavors the beef mixture for a zesty tasting burger. The salsa also serves as a colorful topping. **Makes 6 burger patties.**

Ingredients

- 1 large tomato, seeded and finely chopped
- 1/2 cup finely chopped green pepper
- 1/4 cup finely chopped red onion
- 2 finely chopped, seeded jalapeno peppers
- 1 garlic clove, minced
- 1 tablespoon snipped cilantro

- 1/4 teaspoon salt
- 1 1/2 pounds lean ground beef
- 2 cups shredded lettuce
- 1/3 cup finely shredded cheddar cheese
- 1/4 cup dairy sour cream and /or guacamole

Preparing the Salsa

Combine tomato, green pepper, onion, jalapeno peppers, garlic, cilantro and salt in a bowl. Set aside 2 tablespoons of salsa. Cover and chill remaining salsa until serving time.

Preparing Burgers

In another bowl, combine ground beef with 2 tablespoons of reserved salsa, mix well. Shape mixture into six 1/2 inch thick burgers and place on the grill directly over medium heat with hood up. Grill for 13 to 15 minutes or until no pink remains. Turn burgers once, halfway through grilling time. Arrange the shredded lettuce on individual plates. Top lettuce with a burger, cheddar cheese and salsa. Serve with sour cream and/or guacamole.

CHICAGO STYLE HOT DOGS

Serve these hot dogs "Chicago-style" with pickled peppers! **Makes 4 servings.**

Ingredients

- 1/3 cup ketchup
- 1/4 cup chopped pickled peppers
- 2 tablespoons pickle relish
- 2 tablespoons chopped onion
- 1/4 teaspoon poppy seed
- 4 fully cooked 4-ounce jumbo hot dogs
- 4 hot dog buns

Preparing the Relish

Combine ketchup, chopped pickled peppers, relish, onion and poppy seed in a small bowl, then set aside.

Preparing Hot Dogs

Place hot dogs on grill directly over medium heat 5 to 8 minutes with the lid up. Turn hot dogs and brush with some of the relish mixture. Grill hot dogs 6 to 8 minutes more or until thoroughly cooked.

To Serve

Toast inner sides of hot dog buns on grill. Serve hot dogs inside buns and top with remaining relish mixture.

RIB EYE STEAKS WITH GRILLED GARLIC

As they cook, the garlic cloves mellow in flavor, making a delicious sauce for any grilled meat. And for an appetizer, spread the softened cloves over toasted slices of french bread! **Makes 4 servings.**

Ingredients

- 1 whole head of garlic
- 2 tablespoons olive oil or cooking oil
- 1 tablespoon snipped fresh basil, or 1/2 teaspoon dried basil, crushed
- 1 tablespoon snipped fresh rosemary or 1/2 teaspoon dried rosemary, crushed
- 2 twelve-oz. boneless rib eye steaks

Preparing the Garlic

Use a cooking pan or tear off a 24x18-inch piece of aluminum foil and fold long length in half, then trim to make a 12-inch square. Remove the outer layer of garlic head, then cut off and discard the top 1/2-inch of garlic head to expose the garlic cloves. Place garlic head in center of a cooking pan or in center of foil with all sides of the foil folded up around the garlic to form a cup. Drizzle garlic with oil and sprinkle with basil and rosemary. Cover pan or twist the ends of the foil to completely enclose the garlic.

Preparing Steaks

Place steaks and the garlic pack on grill directly over medium heat and cook about 7 minutes with the lid up. Turn steaks and grill for 5 to 8 minutes more, or until cooked to taste. Then remove steaks and place on platter. Remove garlic and drizzle its juices over your steak. Remove the softened garlic cloves and spread over your steak. Season with salt and pepper as desired and cut into serving-size pieces.

HERB-PEPPER SIRLOIN STEAK

The hearty beef flavor is complemented with a delicious herb coating! **Makes 6 servings.**

Ingredients

- 2 tablespoons ketchup
- 1/2 teaspoon coarsely ground pepper
- 1 1/2 teaspoons snipped fresh rosemary or 1/2 teaspoon dried rosemary, crushed
- 1 1/2 teaspoons snipped fresh basil or 1/2 teaspoon dried basil, crushed
- 1/8 teaspoon garlic powder
- 1 1 1/2-pound boneless beef sirloin steak, cut 1-inch thick

Preparation

Combine ketchup, pepper, rosemary, basil and garlic powder. Coat both sides of steak with mixture. Grill steak with hood up, directly over medium heat for 6 minutes. Turn steak and grill for 8 to 12 minutes more or until cooked as desired. Cut into serving size pieces.

BARBECUED RIBS

Serve this tangy barbecue classic with corn-on-the-cob, green salad, potato salad or coleslaw! **Makes 4 servings.**

Ingredients

- 2 pounds American style pork spareribs
- 1/2 cup barbecue sauce
- 1/2 cup tomato sauce
- 2 cloves garlic, crushed
- juice of 1 lemon
- few drops of tobasco sauce

Preparation

Place ribs into a large glass or ceramic dish. Combine remaining ingredients and pour over the ribs. Refrigerate for several hours.

Preheat your grill 3 minutes and place the ribs on cooking grid. Cook indirectly, over a low to medium heat until cooked. During the last few minutes of cooking you can cook the ribs over a direct fire for added barbecue flavor and texture.

MARINATED TUNA STEAK

Experiment with unique dishes, like this tuna steak recipe boasting a delicious wine marinade! **Makes 4 servings.**

Ingredients

- 4 6-ounce fresh or frozen tuna steaks cut 1 inch thick. Thaw fish if frozen
- 1/3 cup dry white wine
- 1 tablespoon lemon juice
- 1 tablespoon olive oil or cooking oil
- 1 clove garlic, minced
- 2 teaspoons snipped fresh rosemary, crushed, or 1/2 teaspoon dried rosemary, crushed
- 1 teaspoon snipped fresh oregano, crushed, or 1/4 teaspoon dried oregano, crushed
- 1/4 teaspoon salt

Preparation

Combine wine, oil, garlic, rosemary, oregano and salt. Place tuna steak in plastic bag and into shallow dish, add marinade then seal bag. Rotate bag to coat fish well then chill for up to 2 hours, turning fish once.

Remove fish from bag and discard marinade. Place a cooking pan with baking rack or roasting rack into center of grill with outer burners on medium heat. Cook tuna steak on top of rack with lid down for 8 to 12 minutes or until fish begins to flake easily. Turn fish once during cooking. When cooked, remove fish from grill and serve.

MUSTARD-GLAZED HALIBUT STEAKS

A simple sauce of melted margarine, lemon juice, Dijon-style mustard and basil adds a scintillating note to these sizzling fish steaks! **Makes 4 servings.**

Ingredients

- 4 6-ounce fresh or frozen halibut steaks, cut 1 inch thick
- 2 tablespoons margarine or butter
- 2 tablespoons lemon juice
- 1 tablespoon Dijon-style mustard
- 2 teaspoons snipped fresh basil or 1/2 teaspoon dried basil, crushed

Preparation

Combine thawed fish, margarine or butter, lemon juice, mustard and basil into a cooking pan or aluminum foil rectangle, and cook directly over low flame until melted. Brush mixture over both sides of halibut fish steaks. Pour balance of mixture into small bowl.

Place clean cooking pan or foil on center of grill with both outer burners on medium. Place fish on grill and close lid. Cook indirectly for 8 to 12 minutes or just until fish begins to flake easily, turning once and brushing as needed with remaining mixture.

ALMOND COATED TROUT

This delicious recipe is unique and easy to prepare on your Kenmore Elite gas grill. **Makes 4 servings.**

Ingredients

- 2 trout
- 1/2 cup all purpose flour
- 1 egg, lightly beaten
- 1 cup sliced almonds
- 1/3 cup parmesan cheese, grated
- olive or peanut oil for frying

Preparation

Remove the head and tail from trout and fillet all bones. Cut each fish in half to form 4 long fillets. Coat fish in flour, dip in egg and roll in almonds. Refrigerate for 1 hour.

Fill a cast-iron pan with 1 to 2 inches of oil, and place over high heat. Cook trout until golden brown. Drain oil, sprinkle trout with parmesan cheese and serve right from the grill.

SOUTHWEST CHICKEN BREASTS

This popular recipe can also be a grilled chicken salad! Slice chicken into small strips and place them on top of shredded lettuce with avocado dressing and top with cheese! **Makes 6 servings.**

Ingredients

- 1/4 cup dry white wine
- 2 tablespoons olive oil or cooking oil
- 2 teaspoons snipped fresh tarragon or 1/4 teaspoon dried tarragon, crushed
- 1/4 teaspoon salt
- 6 skinless, boneless chicken breast halves
- 2 avocados, pitted, peeled and chopped
- 1 tomato, chopped
- 1 clove garlic, minced
- 2 tablespoons finely chopped seeded green chili peppers of your choice
- 2 green onions, finely chopped
- 1 tablespoon snipped fresh cilantro
- 1 tablespoon honey
- 1 tablespoon lemon juice

Preparing the Chicken

Combine wine, oil, tarragon and salt. Rinse chicken and dry with paper towels. Place chicken in plastic bag and into shallow dish then add marinade and seal bag. Rotate chicken to coat well and chill up to 24 hours, turning bag occasionally.

Preparing the Avocado Dressing

Combine avocados, tomato, garlic, chili peppers, onions, cilantro, honey and lemon juice. Toss well then cover and chill up to 2 hours.

Grilling the Chicken

Remove the chicken from plastic bag and reserve the marinade. Grill chicken directly over medium heat with lid up for 5 minutes. Turn chicken and brush with marinade, then grill for 5-10 minutes more or until chicken is no longer pink. Serve with side of avocado dressing.

BARBECUED CHICKEN

Another backyard favorite, this recipe includes an easy to make, sweet and spicy sauce. **Makes 4 servings.**

Ingredients

- 1/2 cup ketchup
- 1/4 cup orange marmalade
- 1 tablespoon vinegar
- 1/2 teaspoon celery seed
- 1/2 teaspoon chili powder
- 1/4 to 1/2 teaspoon bottled hot pepper sauce
- 1 2 1/2 to 3 pound broiler-fryer chicken, pre-cut

Preparing the Sauce

Combine ketchup, marmalade, vinegar, celery seed, chili powder and hot pepper sauce in a cooking pan, and cook directly over a low to medium heat. Leave the cooked sauce in the pan and remove from heat until chicken is prepared.

Preparing the Chicken

Wash chicken and dry with paper towels. Turn outside burners on medium and place pre-cut chicken pieces (bone side down) in center of grill. Close lid and cook indirectly for 1 hour or until chicken is no longer pink. Brush occasionally with sauce. Remove chicken from grill once cooked, then place cooking pan with sauce into center of grill and reheat. Pour warmed sauce over chicken and serve.

TRADITIONAL HOLIDAY TURKEY

Imagine everyone's surprise when you serve your next holiday turkey complete with dressing delicious and tender straight from the grill! **Serves 8 - 10**

Ingredients for Turkey

- 8 - 10 pound whole turkey
- 4 ounces butter, softened
- 2 tablespoons chopped thyme
- 2 tablespoons lemon juice
- 2 teaspoons grated lemon rind

Ingredients for Dressing

- 2 ounces butter
- 2 onions, finely chopped
- 8 ounces bacon, chopped
- 2 tablespoons port wine
- 1/4 cup red wine
- 2 chicken stock cubes
- 4 ounces chopped cashews, hazelnuts or pecans
- 1/2 cup chopped celery
- 1/2 cup chopped carrot
- 1 - 1 1/2 cups fresh white breadcrumbs
- 1 egg, lightly beaten
- salt and pepper to taste

Preparing the Dressing

Prepare dressing in a cooking pan directly over medium heat. Melt butter, add onions and bacon then saute 3 minutes. Add port, red wine and stock cubes and bring to a boil. Cook 2 minutes. Remove pan to allow ingredients to cool. Add remaining ingredients and mix.

Preparing the Turkey

Although not required, you may want to preheat your grill 3 minutes.

Wash inside of turkey and dry with paper towels. Pack breadcrumb seasoning into the turkey cavity. Combine the butter, thyme, lemon juice and rind together in a bowl. Using turkey baster, insert butter mixture under skin covering the turkey breast.

Truss the turkey with string and place it on a baking pan or roasting rack that rests into a cooking pan. Remove the cooking grids from your grill if necessary, then place the cooking pan and turkey in the center of your grill. Turn one outside burner to low, the other to medium, and close lid. Cook indirectly for 3 1/2 to 4 hours or until cooked. Halfway through cooking time you may alternate burner temperatures so that the turkey browns evenly. Once cooked, remove dressing from cooked turkey, slice and serve.

PIZZA ON THE GRILL

You may never want to call out for pizza again! Follow this pizza dough recipe, or purchase ready-made pizza dough found in your grocers refrigerated section next to the biscuits. Slice and serve directly from the grill. **Serves 6 - 8**

Ingredients

- 1 1/2 teaspoons dried yeast
- 1 cup lukewarm water
- 1/2 teaspoon sugar
- 3 tablespoons olive oil
- 3 cups all purpose flour
- 1/4 cup tomato paste or Italian tomato sauce
- 6 ounces sliced pepperoni
- 1 red pepper, roasted and sliced
- 3/4 cup pitted black olives
- 8 ounces grated mozzarella cheese

It's easy to customize this recipe with toppings to suit your family's taste. For spicier crust, lightly rub the dough with olive oil then spice with pepper and garlic salt before spreading your tomato sauce.

Preparing the Pizza Dough

Combine yeast, water and sugar together and let stand in a warm place until mixture starts to foam. Add this yeast mixture to flour and oil and combine to form your pizza dough. Knead on a lightly floured surface until smooth and elastic. Cover and stand in a warm place until doubled in size. Knock back dough and roll out to a rectangle the size of your cooking pan or baking dish. Place dough into a lightly oiled pan.

If you purchased a ready-made pizza dough, simply open can and roll dough into a lightly oiled cooking pan.

Preparing the Pizza

Spread tomato paste or Italian tomato sauce on top of your pizza dough. Top with pepperoni, red peppers, olives, and lastly, mozzarella cheese. Or if you prefer, you may place cheese first with toppings on last.

Place cooking pan in center of grill and cook indirectly, with one outside burner on high and the other on low, for approximately 20 minutes or until bottom of crust is light brown. Lastly, raise the lid and finish cooking pizza by turning burner under the cooking pan on high for about 2 minutes. This will insure the center of pizza gets brown. Then turn off heat, slice and serve directly from pan.

FRESH VEGETABLE STIR-FRY

Take a trip to the Orient with this easy, and healthy vegetable recipe. **Makes 4 - 6 servings.**

Ingredients

- 2 tablespoons oil
- 1 onion, cut into wedges
- 1 carrot, thinly sliced
- 2 cups broccoli, cut into small flowerets
- 1 red pepper, sliced
- 2 sticks celery, thinly sliced
- 1 cup snow peas
- 1/2 cup chicken broth

Preparation

Heat oil in a wok or saute pan, directly over a high heat. Add onion and cook 1 minute. Add carrot and broccoli and stir-fry 2 minutes, then add red pepper, celery and snow peas and continue cooking 1 minute more. Add chicken broth and toss vegetables until cooked to desired doneness.

ONION BLOSSOMS

Great served as a snack, or to dress up barbecued meats, poultry or fish. **Makes 4 servings.**

Ingredients

- 4 medium sweet onions (4-5 ounces each)
- 1 tablespoons margarine or butter, melted
- 1 teaspoon Dijon-style mustard
- 1/8 teaspoon hot pepper sauce
- 1 tablespoon brown sugar
- 1 pepper (optional)

Preparation

Peel onions, then cut almost completely through each onion, forming 8 wedges. Onion will be loose, but still be intact. Prepare four 12-inch squares of aluminum foil. Place one onion in the center of each foil square.

Stir margarine (or butter) with hot pepper sauce and drizzle over onions. Sprinkle with brown sugar. Then bring up two sides of foil square and double fold. Bring remaining corners up and completely enclose - leaving enough space for steam to build.

Place wrapped onion blossoms on grill, directly over medium heat. Close lid and cook 15 to 25 minutes or until onions are nearly tender. Make a 2-inch opening at the top of each onion wrapping, then close lid and cook 5 to 10 minutes more, or until onions are lightly browned. Sprinkle with pepper if desired and serve warm.

GRILLED POTATO SKINS

Serve these crispy potatoes as a snack or side dish. We've included microwave instructions for a timesaving short cut. **Makes 12 servings.**

Ingredients

- 6 baking potatoes (about 8 ounces each)
- 3 tablespoons margarine or butter, melted
- 1/2 cup picante sauce
- 1 cup shredded cheddar cheese (4 ounces)
- 3 slices bacon, crisp-cooked and crumbled or use prepackaged bacon bits
- 1 chopped tomato (optional)
- 1 diced green onion (optional)
- 1/2 cup sour cream (optional)

Preparation

Puncture clean potatoes with a fork, wrap in aluminum foil and place directly over low to medium heat. Close lid and cook directly for 1 hour or until center is tender. OR - Microwave clean, punctured potatoes on high for 15 to 20 minutes, or until center tender. Allow cooked potatoes to cool then unwrap and discard foil.

Cut potatoes in half - lengthwise. Scoop out potato pulp (serve separately or discard.) Be sure to leave 1/4-inch thick potato shell remaining. Brush the inside of each potato shell with melted margarine. Spoon 2 teaspoons picante sauce into each potato shell, sprinkle with cheese and top with bacon.

Place prepared potato skins on grill, directly over medium heat. Close lid and cook for 8 to 10 minutes or until potato skins are crisp. Sprinkle each potato skin with tomato and green onion and then top with sour cream, if desired.

Notes

Get it fixed, at your home or ours!

For repair of major brand appliances **in your own home...**
no matter who made it, no matter who sold it!

1-800-4-MY-HOMESM Anytime, day or night
(1-800-469-4663)

www.sears.com

To bring in products such as vacuums, lawn equipment and electronics
for repair, call for the location of your nearest **Sears Parts & Repair Center.**

1-800-488-1222 Anytime, day or night

www.sears.com

For the replacement parts, accessories and owner's manuals
that you need to do-it-yourself, call **Sears PartsDirect**SM!

1-800-366-PART 6 a.m. – 11 p.m. CST,
(1-800-366-7278) 7 days a week

www.sears.com/partsdirect

To purchase or inquire about a Sears Service Agreement:

1-800-827-6655

7 a.m. – 5 p.m. CST, Mon. – Sat.

Para pedir servicio de reparación a domicilio,
y para ordenar piezas con entrega a domicilio:

1-888-SU-HOGARSM
(1-888-784-6427)

Au Canada pour service en français:

1-877-LE-FOYERSM
(1-877-533-6937)

