

Owner's Manual



23.0 HP ELECTRIC START 48" MOWER AUTOMATIC GARDEN TRACTOR

Model No.
917.275240

- Safety
- Assembly
- Operation
- Maintenance
- Repair Parts

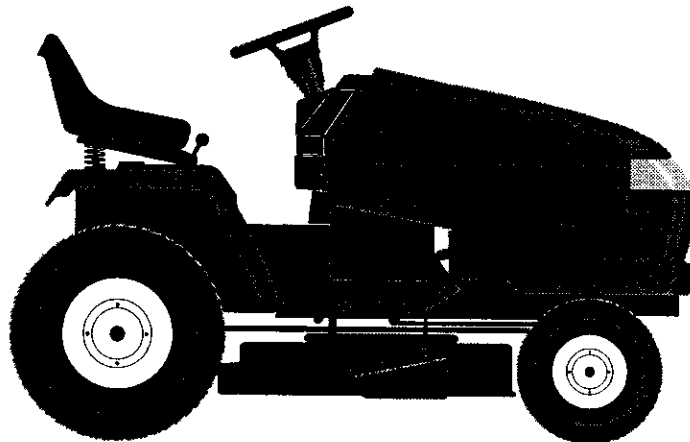

This product has a low emission engine which operates differently from previously built engines. Before you start the engine, read and understand this Owner's Manual.

CAUTION:

Read and follow all Safety Rules and Instructions before operating this equipment.

For answers to your questions about this product, Call:

1-800-659-5917

Sears Craftsman Help Line
5 am - 5 pm, Mon - Sat

Sears, Roebuck and Co., Hoffman Estates, IL 60179
Visit our Craftsman website: www.sears.com/craftsman

TABLE OF CONTENTS

Warranty	2	Maintenance	20
Safety Rules	3	Service and Adjustments	26
Product Specifications	6	Storage	34
Assembly	8	Troubleshooting	35
Operation	13	Repair Parts	39
Maintenance Schedule	20	Parts Ordering	Back Cover

WARRANTY

LIMITED TWO YEAR WARRANTY ON CRAFTSMAN RIDING EQUIPMENT PARTS

For two (2) years from the date of purchase, if this Craftsman Riding Equipment is maintained, lubricated and tuned up according to the instructions in the owner's manual, Sears will repair or replace, free of charge, any parts found to be defective in material or workmanship. Warranty service is available free of charge by returning your Craftsman riding equipment to your nearest Sears Service Center. In-home warranty service is available but a trip charge will apply. This warranty applies only while this product is in the United States.

This Warranty does not cover:

- Expendable items which become worn during normal use, such as blades, spark plugs, air cleaners, belts and oil filters.
- Tire replacement or repair caused by punctures from outside objects, such as nails, thorns, stumps, or glass.
- Repairs necessary because of operator abuse, including but not limited to, damage caused by towing objects beyond the capability of the riding equipment, impacting objects that bend the frame or crankshaft, or over speeding the engine.
- Repairs necessary because of operator negligence, including but not limited to, electrical and mechanical damage caused by improper storage, failure to use the proper grade and amount of engine oil, failure to keep the deck clear of flammable debris, or the failure to maintain the equipment according to the instructions contained in the owner's manual.
- Engine (fuel system) cleaning or repairs caused by fuel determined to be contaminated or oxidized (stale). In general, fuel should be used within thirty (30) days of its purchase date.
- Riding equipment used for commercial or rental purposes. A product is "used for commercial purpose" if is used for any purpose other than single family household dwellings or in usage where profit is made.

LIMITED 90 DAY WARRANTY ON BATTERY

For ninety (90) days from date of purchase, if any battery included with this riding equipment proves defective in material or workmanship and our testing determines the battery will not hold a charge, Sears will replace the battery at no charge. Warranty service is available free of charge by returning your Craftsman riding equipment to your nearest Sears Service Center. In-home warranty service is available but a trip charge will apply. This warranty applies only while this product is in the United States.

TO LOCATE THE NEAREST SEARS SERVICE CENTER OR TO SCHEDULE IN-HOME WARRANTY SERVICE, SIMPLY CONTACT SEARS AT 1-800-4-MY-HOME

This Warranty gives you specific legal rights, and you may also have other rights which may vary from state to state.

Sears, Roebuck and Co., D/817 WA, Hoffman Estates, IL 60179

SAFETY RULES

IMPORTANT: This cutting machine is capable of amputating hands and feet and throwing objects. Failure to observe the following safety instructions could result in serious injury or death.

GENERAL OPERATION

- Read, understand, and follow all instructions in the manual and on the machine before starting.
- Only allow responsible adults, who are familiar with the instructions, to operate the machine.
- Clear the area of objects such as rocks, toys, wire, etc., which could be picked up and thrown by the blade.
- Be sure the area is clear of other people before mowing. Stop machine if anyone enters the area.
- Never carry passengers.
- Do not mow in reverse unless absolutely necessary. Always look down and behind before and while backing.
- Be aware of the mower discharge direction and do not point it at anyone. Do not operate the mower without either the entire grass catcher or the guard in place.
- Slow down before turning.
- Never leave a running machine unattended. Always turn off blades, set parking brake, stop engine, and remove keys before dismounting.
- Turn off blades when not mowing.
- Stop engine before removing grass catcher or unclogging chute.
- Mow only in daylight or good artificial light.
- Do not operate the machine while under the influence of alcohol or drugs.
- Watch for traffic when operating near or crossing roadways.
- Use extra care when loading or unloading the machine into a trailer or truck.
- Data indicates that operators, age 60 years and above, are involved in a large percentage of riding mower-related injuries. These operators should evaluate their ability to operate the riding mower safely enough to protect themselves and others from serious injury.
- Keep machine free of grass, leaves or other debris build-up which can touch hot exhaust / engine parts and burn. Do not allow the mower deck to plow leaves or other debris which can cause

build-up to occur. Clean any oil or fuel spillage before operating or storing the machine. Allow machine to cool before storage.

SLOPE OPERATION

Slopes are a major factor related to loss-of-control and tipover accidents, which can result in severe injury or death. All slopes require extra caution. If you cannot back up the slope or if you feel uneasy on it, do not mow it.

DO:

- Mow up and down slopes, not across.
- Remove obstacles such as rocks, tree limbs, etc.
- Watch for holes, ruts, or bumps. Uneven terrain could overturn the machine. Tall grass can hide obstacles.
- Use slow speed. Choose a low gear so that you will not have to stop or shift while on the slope.
- Follow the manufacturer's recommendations for wheel weights or counterweights to improve stability.
- Use extra care with grass catchers or other attachments. These can change the stability of the machine.
- Keep all movement on the slopes slow and gradual. Do not make sudden changes in speed or direction.
- Avoid starting or stopping on a slope. If tires lose traction, disengage the blades and proceed slowly straight down the slope.

DO NOT:

- *Do not* turn on slopes unless necessary, and then, turn slowly and gradually downhill, if possible.
- *Do not* mow near drop-offs, ditches, or embankments. The mower could suddenly turn over if a wheel is over the edge of a cliff or ditch, or if an edge caves in.
- *Do not* mow on wet grass. Reduced traction could cause sliding.
- *Do not* try to stabilize the machine by putting your foot on the ground.
- *Do not* use grass catcher on steep slopes.

SAFETY RULES

CHILDREN

Tragic accidents can occur if the operator is not alert to the presence of children. Children are often attracted to the machine and the mowing activity. *Never* assume that children will remain where you last saw them.

- Keep children out of the mowing area and under the watchful care of another responsible adult.
- Be alert and turn machine off if children enter the area.
- Before and when backing, look behind and down for small children.
- Never carry children. They may fall off and be seriously injured or interfere with safe machine operation.
- Never allow children to operate the machine.
- Use extra care when approaching blind corners, shrubs, trees, or other objects that may obscure vision.

SERVICE

- Use extra care in handling gasoline and other fuels. They are flammable and vapors are explosive.
 - Use only an approved container.
 - Never remove gas cap or add fuel with the engine running. Allow engine to cool before refueling. Do not smoke.
 - Never refuel the machine indoors.
 - Never store the machine or fuel container inside where there is an open flame, such as a water heater.

- Never run a machine inside a closed area.
- Keep nuts and bolts, especially blade attachment bolts, tight and keep equipment in good condition.
- Never tamper with safety devices. Check their proper operation regularly.
- Keep machine free of grass, leaves, or other debris build-up. Clean oil or fuel spillage. Allow machine to cool before storing.
- Stop and inspect the equipment if you strike an object. Repair, if necessary, before restarting.
- Never make adjustments or repairs with the engine running.
- Grass catcher components are subject to wear, damage, and deterioration, which could expose moving parts or allow objects to be thrown. Frequently check components and replace with manufacturer's recommended parts, when necessary.
- Mower blades are sharp and can cut. Wrap the blade(s) or wear gloves, and use extra caution when servicing them.
- Check brake operation frequently. Adjust and service as required.



- Be sure the area is clear of other people before mowing. Stop machine if anyone enters the area.
- Never carry passengers or children even with the blades off.
- Do not mow in reverse unless absolutely necessary. Always look down and behind before and while backing.
- Never carry children. They may fall off and be seriously injured or interfere with safe machine operation.
- Keep children out of the mowing area and under the watchful care of another responsible adult.
- Be alert and turn machine off if children enter the area.
- Before and when backing, look behind and *down* for small children.
- Mow up and down slopes (15° Max), not across.
- Remove obstacles such as rocks, tree limbs, etc.
- Watch for holes, ruts, or bumps. Uneven terrain could overturn the machine. *Tall grass can hide obstacles.*

SAFETY RULES

- Use slow speed. Choose a low gear so that you will not have to stop or shift while on the slope.
- Avoid starting or stopping on a slope. If tires lose traction, disengage the blades and proceed slowly *straight* down the slope.
- If machine stops while going uphill, disengage blades, shift into reverse and back down slowly.
- *Do not* turn on slopes unless necessary, and then, turn slowly and gradually downhill, if possible.

▲Look for this symbol to point out important safety precautions. It means CAUTION!!! BECOME AWARE!!! YOUR SAFETY IS INVOLVED.

▲CAUTION: In order to prevent accidental starting when setting up, transporting, adjusting or making repairs always disconnect spark plug wire and place wire where it cannot contact spark plug.

▲CAUTION: Do not coast down a hill in neutral, you may lose control of the tractor.

▲CAUTION: Tow only the attachments that are recommended by and comply with specifications of the manufacturer of your tractor. Use common sense when towing. Operate only at the lowest possible speed when on a slope. Too heavy of a load, while on a slope, is dangerous. Tires can lose traction with the ground and cause you to lose control of your tractor.

▲WARNING: Engine exhaust, some of its constituents, and certain vehicle components contain or emit chemicals known to the State of California to cause cancer and birth defects or other reproductive harm.

▲WARNING: Battery posts, terminals and related accessories contain lead and lead compounds, chemicals known to the State of California to cause cancer and birth defects or other reproductive harm. **Wash hands after handling.**

PRODUCT SPECIFICATIONS

GASOLINE CAPACITY AND TYPE:	3.5 GALLONS UNLEADED REGULAR
OIL TYPE (API-SF-SJ):	SAE 10W30 (ABOVE 32°F) SAE 5W-30 (BELOW 32°F)
OIL CAPACITY:	W/FILTER: 4.0PINTS W/O FILTER: 3.5PINTS
COOLANT TYPE:	ETHYLENE GLYCOL ANTIFREEZE
COOLANT CAPACITY:	1.47 QUARTS
SPARK PLUG: (GAP: .030")	CHAMPION RC14YC
GROUND SPEED(MPH):	FORWARD: 5.8 REVERSE: 2.1
TIRE PRESSURE:	FRONT: 14 PSI REAR: 10 PSI
CHARGING SYSTEM:	15AMPS @ 3600RPM
BATTERY:	AMP/HR: 35 MIN. CCA: 280 CASE SIZE:U1R
BLADE BOLT TORQUE:	45-55 FT. LBS

CONGRATULATIONS on your purchase of a new tractor. It has been designed, engineered and manufactured to give you the best possible dependability and performance.

Should you experience any problem you cannot easily remedy, please contact your nearest Sears Authorized Service Center. We have competent, well-trained technicians and the proper tools to service or repair this tractor.

Please read and retain this manual. The instructions will enable you to assemble and maintain your tractor properly. Always observe the "SAFETY RULES".

REPAIR AGREEMENT

A Sears Repair Agreement is available on this product. Contact your nearest Sears store for details.

CUSTOMER RESPONSIBILITIES

- Read and observe the safety rules.
- Follow a regular schedule in maintaining, caring for and using your tractor.
- Follow the instructions under "Maintenance" and "Storage" sections of this owner's manual.

⚠WARNING: This tractor is equipped with an internal combustion engine and should not be used on or near any unimproved forest-covered, brush-covered or grass-covered land unless the engine's exhaust system is equipped with a spark arrester meeting applicable local or state laws (if any). If a spark arrester is used, it should be maintained in effective working order by the operator.

In the state of California the above is required by law (Section 4442 of the California Public Resources Code). Other states may have similar laws. Federal laws apply on federal lands. A spark arrester for the muffler is available through your nearest Sears Authorized Service Center (See REPAIR PARTS section of this manual).

UNASSEMBLED PARTS

Steering Wheel

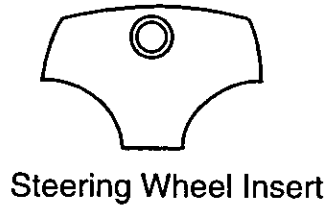
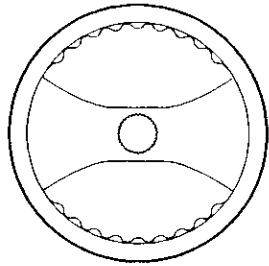

Seat

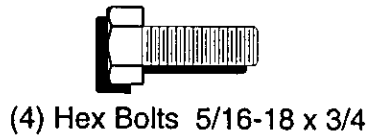
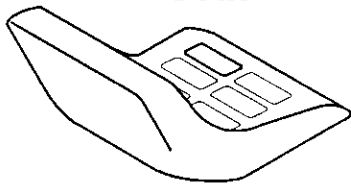

Mower

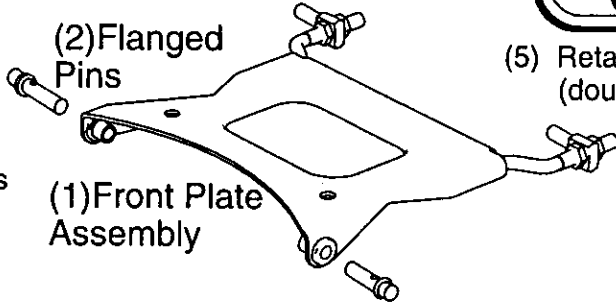
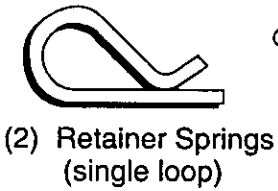

(2) Flanged Pins

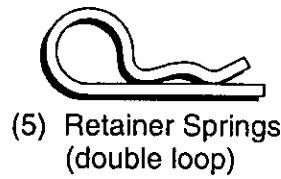

Gauge Wheels

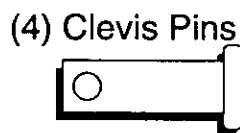
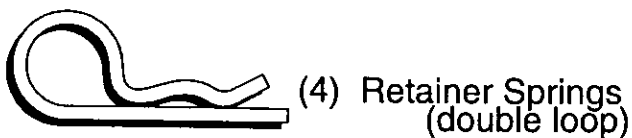
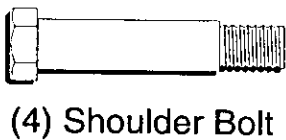
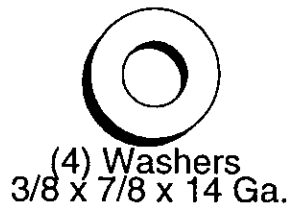

UNASSEMBLED PARTS

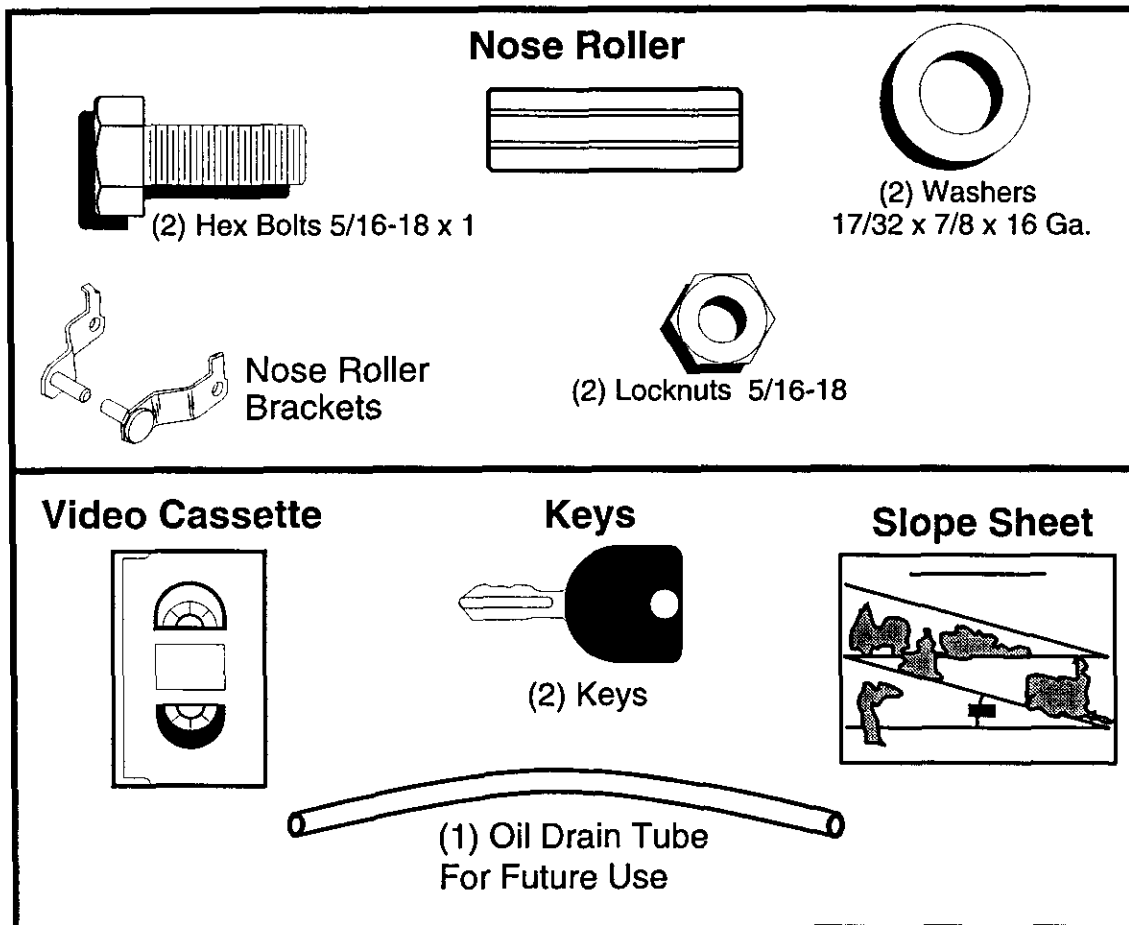

ASSEMBLY

Your new tractor has been assembled at the factory with exception of those parts left unassembled for shipping purposes. To ensure safe and proper operation of your tractor all parts and hardware you assemble must be tightened securely. Use the correct tools as necessary to insure proper tightness. Review the video cassette before you begin.

TOOLS REQUIRED FOR ASSEMBLY

A socket wrench set will make assembly easier. Standard wrench sizes you need are listed below.

- | | |
|---------------------------------------|-------------------|
| (1) 9/16" wrench | (1) Pliers |
| (1) 1/2" wrench | (1) Utility knife |
| (1) 3/4" socket with
drive ratchet | |
| (1) Tire pressure gauge | |

When right or left hand is mentioned in this manual, it means, from your point of view, when you are in the operating position (seated behind the steering wheel).

TO REMOVE TRACTOR FROM CARTON

UNPACK CARTON

1. Remove all accessible loose parts and parts boxes from shipping carton.
2. Cut, from top to bottom, along lines on all four corners of shipping carton, and lay panels flat.
3. Remove mower and packing materials.
4. Check for any additional loose parts or boxes and remove.

ASSEMBLY

BEFORE REMOVING TRACTOR FROM SKID

ATTACH STEERING WHEEL

1. Remove hex bolt, lock washer and large flat washer from steering shaft.
2. Position front wheels of the tractor so they are pointing straight forward.
3. Slide the steering sleeve over the steering shaft.
4. Position steering wheel so cross bars are horizontal (left to right) and slide onto steering wheel adapter.
5. Secure steering wheel to steering shaft with hex bolt, lock washer and large flat washer previously removed. Tighten securely.
6. Snap steering wheel insert into center of steering wheel.
7. Remove protective materials from tractor hood and grill.

IMPORTANT: Check for and remove any staples in skid that may puncture tires where tractor is to roll off skid.

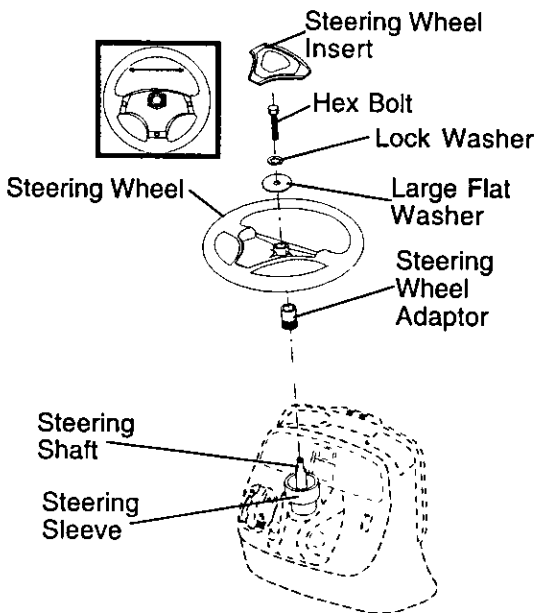

HOW TO SET UP YOUR TRACTOR

CHECK BATTERY

- Lift hood to raised position.
- If this battery is put into service after month and year indicated on label (label located between terminals) charge battery for minimum of one hour at 6-10 amps. (See "BATTERY" in Maintenance section of this manual for charging instructions).

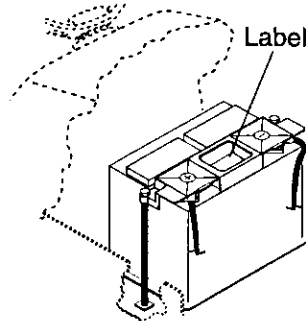

INSTALL SEAT

Seat position should be adjusted forward or backward so that the operator can comfortably reach clutch/brake pedal and safely operate the tractor.

1. Release L.H. seat slide on seat pan by pulling out on adjustment handle and sliding it to the rear position exposing seat mounting holes from bottom. Slide R.H. slide to same rear position.
2. Mount rear of seat on slides using mounting bolts and lock washers as shown.
3. Pull out on adjustment handle and slide seat all the way forward. Install front mounting bolts and lock washers. Tighten all mounting bolts securely.
4. Lower seat into operating position and sit on seat. Press clutch/brake pedal all the way down. If operating position is not comfortable, adjust seat.

To adjust seat: Grasp adjustment handle and pull out, slide seat to desired position and release adjustment handle.

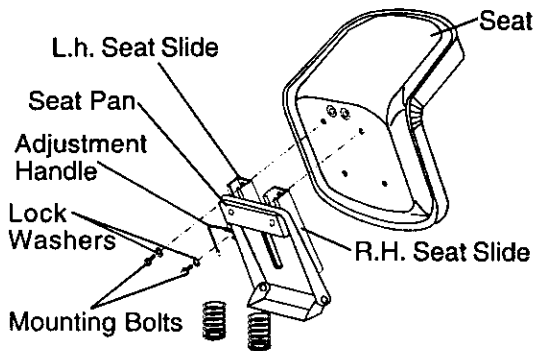

NOTE: You may now roll or drive your tractor off the skid. Follow the appropriate instruction below to remove the tractor from the skid.

TO ROLL TRACTOR OFF SKID

(See Operation section for location and function of controls)

1. Press lift lever plunger and raise attachment lift lever to its highest position.
2. Release parking brake by depressing clutch/brake pedal.
3. Place freewheel control in freewheeling position to disengage transmission (See "TO TRANSPORT" in the Operation section of this manual).
4. Roll tractor forward off skid.

TO DRIVE TRACTOR OFF SKID

(See Operation section for location and function of controls)

WARNING: Before starting, read, understand and follow all instructions in the Operation section of this manual. Be sure tractor is in a well-ventilated area. Be sure the area in front of tractor is clear of other people and objects.

1. Be sure all the above assembly steps have been completed.
2. Check engine oil level and fill fuel tank with gasoline.
3. Place freewheel control in "transmission engaged" position.
4. Sit on seat in operating position, depress clutch/brake pedal and set the parking brake.
5. Place motion control lever in neutral (N) position.
6. Press lift lever plunger and raise attachment lift lever to its highest position.
7. Start the engine. After engine has started, move throttle control to idle position.
8. Release parking brake.
9. Slowly move the motion control lever forward and slowly drive tractor off skid.

10. Apply brake to stop tractor, set parking brake and place gearshift lever in neutral position.

11. Turn ignition key to "OFF" position. Continue with the instructions that follow.

ASSEMBLE GAUGE WHEELS TO MOWER DECK

The gauge wheels are designed to keep the mower deck in proper position when operating mower. Be sure they are properly adjusted to ensure optimum mower performance.

1. Slide gauge wheel bar down into bracket channel, Be sure that gauge wheel bar aligning holes are on top. Assemble gauge wheels as shown using shoulder bolts, 3/8 washers and 3/8-16 center locknuts and tighten securely.
2. For ease of mower to tractor assembly, raise gauge wheels to highest position and retain with clevis pins and spring retainers.

NOTE: Adjust gauge wheels before operating mower. See "TO ADJUST GAUGE WHEELS" in the Operation section of this manual.

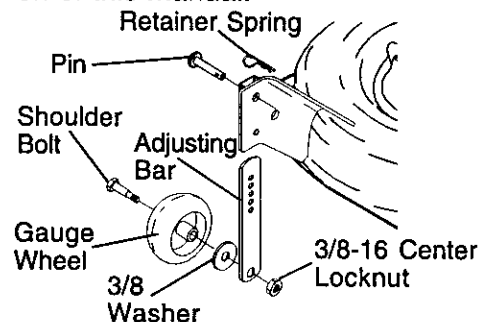

TO ATTACH NOSE ROLLER

1. Position brackets, 17/32 x 7/8 x 16 gauge washers, and nose roller between deck mounting brackets as shown. Be sure to position brackets on correct side, as shown.
2. Install hex bolts and lock nuts as shown. Tighten hardware securely.

NOTE: Be sure bracket tabs are positioned in tab holes in deck brackets.

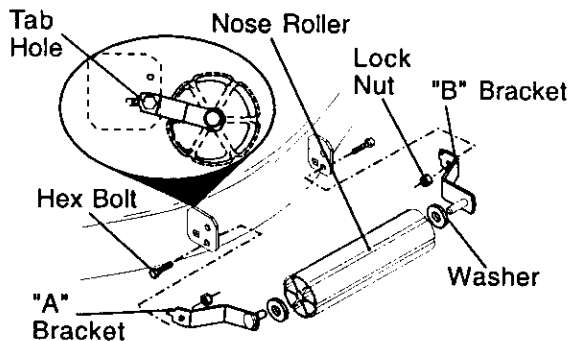

INSTALL MOWER AND DRIVE BELT

Be sure tractor is on level surface and mower suspension arms are raised with attachment lift control. Engage parking brake.

1. Cut and remove ties securing anti-sway bar and belts. Swing anti-sway bar to left side of mower deck.
 2. Slide mower under tractor with deflector shield to right side of tractor.
- IMPORTANT:** Check belt for proper routing in all mower pulley grooves.
3. If equipped, turn height adjustment knob counterclockwise until it stops.
 4. Lower mower linkage with attachment lift control.
 5. Be sure belt tension rod is in disengaged position.
 6. Install belt into electric clutch pulley groove.
 7. Place the suspension arms on outward pointing deck pins. Retain with double loop retainer spring with loops up as shown.
 8. Install front plate assembly to tractor suspension brackets and retain with single loop retainer springs as shown.

9. Position front plate assembly between front mower brackets. Raise deck and plate assembly to align holes and insert flanged pins. Secure pins with double loop retainer springs between the plate assembly and mower brackets.

NOTE: To assist in locating hole in flanged pin, the hole in pin is in line with notch on head of pin. If necessary, move mower side-to-side to give space between plate and mower brackets.

IMPORTANT: Check belt for proper routing in all mower pulley grooves.

10. Engage belt tension rod by pushing rod into locking bracket.

CAUTION: Belt tension rod is spring loaded. Have a tight grip on rod and engage slowly.

11. Connect anti-sway bar to chassis bracket under left footrest and retain with double loop retainer spring.
12. If equipped, turn height adjustment knob clockwise to remove slack from mower suspension.
13. Raise deck to highest position.
14. Adjust gauge wheels before operating mower as shown in the Operation section of this manual.

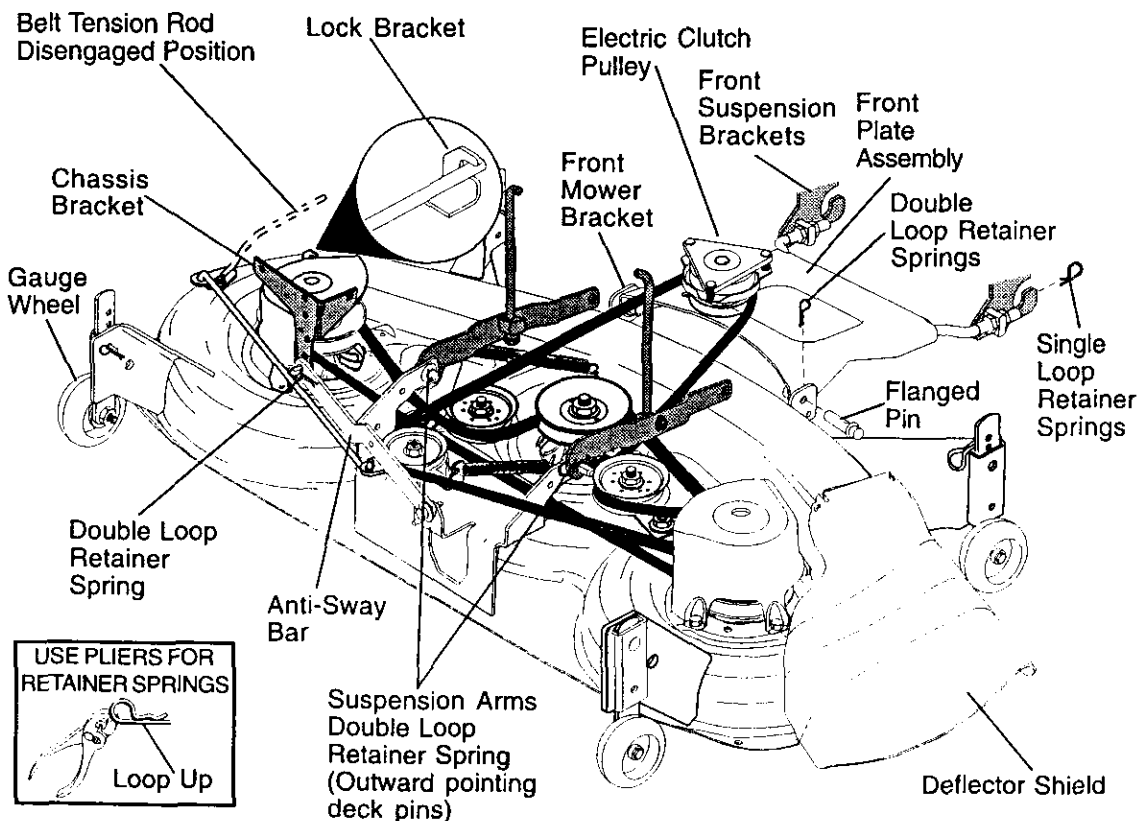

CHECK TIRE PRESSURE

The tires on your tractor were overinflated at the factory for shipping purposes. Correct tire pressure is important for best cutting performance.

- Reduce tire pressure to PSI shown in "PRODUCT SPECIFICATIONS" section of this manual.

CHECK MOWER LEVELNESS

For best cutting results, mower should be properly leveled. See "TO LEVEL MOWER HOUSING" in the Service and Adjustments section of this manual.

CHECK FOR PROPER POSITION OF ALL BELTS

See the figures that are shown for replacing motion, mower drive, and mower blade drive belts in the Service and Adjustments section of this manual. Verify that the belts are routed correctly.

CHECK BRAKE SYSTEM

After you learn how to operate your tractor, check to see that the brake is properly adjusted. See "TO ADJUST BRAKE" in the Service and Adjustments section of this manual.

✓CHECKLIST

BEFORE YOU OPERATE AND ENJOY YOUR NEW TRACTOR, WE WISH TO ASSURE THAT YOU RECEIVE THE BEST PERFORMANCE AND SATISFACTION FROM THIS QUALITY PRODUCT.

PLEASE REVIEW THE FOLLOWING CHECKLIST:

- ✓ All assembly instructions have been completed.
- ✓ No remaining loose parts in carton.
- ✓ Battery is properly prepared and charged. (Minimum 1 hour at 6 amps).
- ✓ Seat is adjusted comfortably and tightened securely.
- ✓ All tires are properly inflated. (For shipping purposes, the tires were overinflated at the factory).
- ✓ Be sure mower deck is properly leveled side-to-side/front-to-rear for best cutting results. (Tires must be properly inflated for leveling).
- ✓ Check mower and drive belts. Be sure they are routed properly around pulleys and inside all belt keepers.
- ✓ Check wiring. See that all connections are still secure and wires are properly clamped.
- ✓ Before driving tractor, be sure free-wheel control is in drive position.

WHILE LEARNING HOW TO USE YOUR TRACTOR, PAY EXTRA ATTENTION TO THE FOLLOWING IMPORTANT ITEMS:

- ✓ Engine oil is at proper level.
- ✓ Engine coolant is at proper level.
- ✓ Fuel tank is filled with fresh, clean, regular unleaded gasoline.
- ✓ Become familiar with all controls - their location and function. Operate them before you start the engine.
- ✓ Be sure brake system is in safe operating condition.
- ✓ It is important to purge the transmission before operating your tractor for the first time. Follow proper starting and transmission purging instructions (See "TO START ENGINE" and "PURGE TRANSMISSION" in the Operation section of this manual).

OPERATION

These symbols may appear on your tractor or in literature supplied with the product. Learn and understand their meaning.

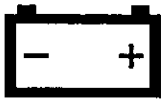

BATTERY



CAUTION OR WARNING



REVERSE



FORWARD



FAST



SLOW



ENGINE ON



ENGINE OFF



OIL PRESSURE

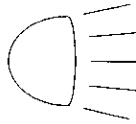

LIGHTS ON



OVER TEMP LIGHT



MOWER LIFT



FUEL



CHOKE



MOWER HEIGHT



PARKING BRAKE LOCKED



UNLOCKED



MOWER LIFT



ATTACHMENT CLUTCH ENGAGED



REVERSE



NEUTRAL



HIGH



LOW



PARKING BRAKE



IGNITION



ATTACHMENT CLUTCH DISENGAGED



KEEP AREA CLEAR



SLOPE HAZARDS

(SEE SAFETY RULES SECTION)



DANGER, KEEP HANDS AND FEET AWAY

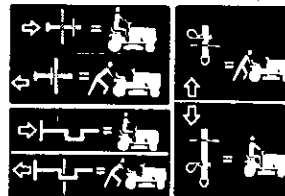

FREE WHEEL
(Automatic Models only)

KNOW YOUR TRACTOR

READ THIS OWNER'S MANUAL AND SAFETY RULES BEFORE OPERATING YOUR TRACTOR

Compare the illustrations with your tractor to familiarize yourself with the locations of various controls and adjustments. Save this manual for future reference.

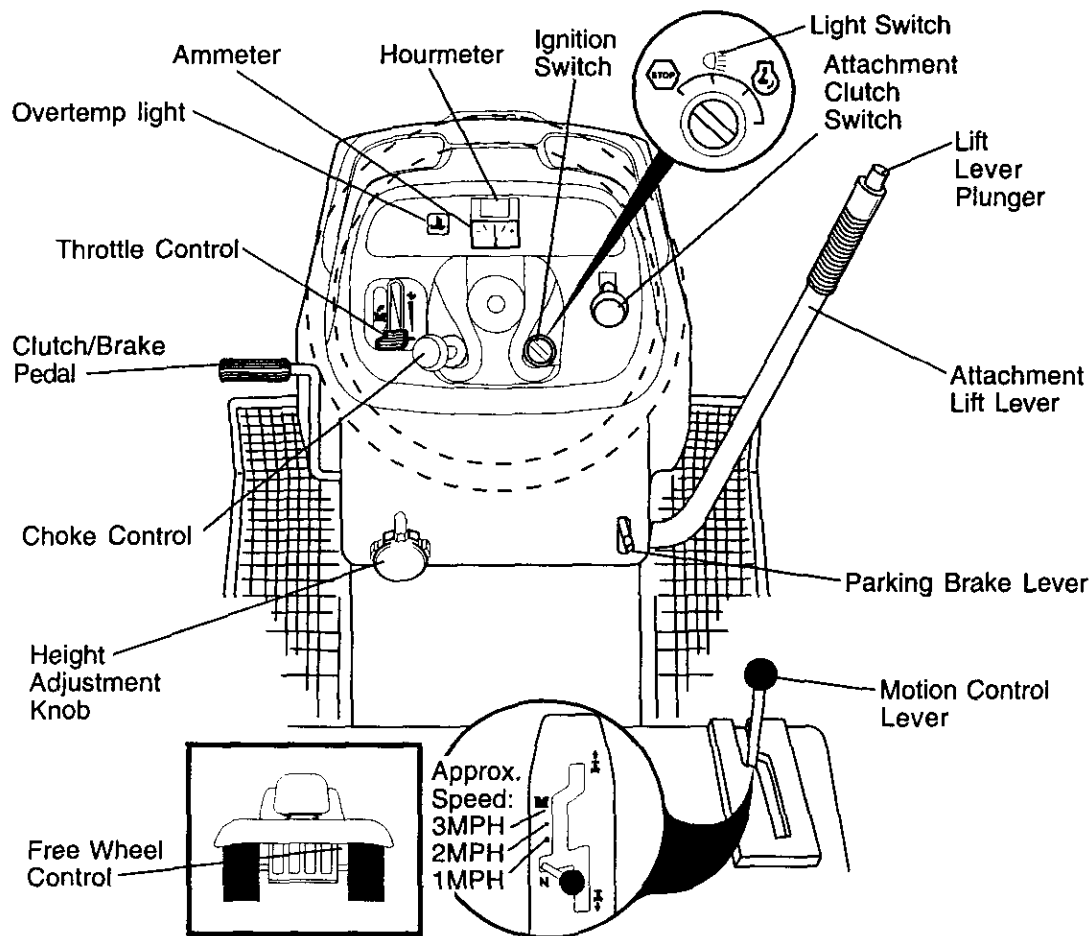

Our tractors conform to the safety standards of the American National Standards Institute.

ATTACHMENT CLUTCH SWITCH -

Used to engage the mower blades, or other attachments mounted to your tractor.

THROTTLE CONTROL - Used to control engine speed.

CLUTCH/BRAKE PEDAL - Used for declutching and braking the tractor and starting the engine.

CHOKE CONTROL - Used when starting a cold engine.

HEIGHT ADJUSTMENT KNOB - Used to adjust the mower cutting height.

IGNITION SWITCH - Used for starting and stopping the engine.

ATTACHMENT LIFT LEVER - Used to raise, lower, and adjust the mower deck or other attachments mounted to your tractor.

LIFT LEVER PLUNGER - Used to release attachment lift lever when changing its position.

AMMETER - Indicates charging (+) or discharging (-) of battery.

PARKING BRAKE LEVER - Locks clutch/brake pedal into the brake position.

MOTION CONTROL LEVER - Selects the speed and direction of tractor.

FREEWHEEL CONTROL - Disengages transmission for pushing or slowly towing the tractor with the engine off.

HOURMETER - Indicates hours of operation.

OVERTEMP LIGHT: Indicates overheated coolant during engine operation.

LIGHT SWITCH - Turns the headlights on and off.



The operation of any tractor can result in foreign objects thrown into the eyes, which can result in severe eye damage. Always wear safety glasses or eye shields while operating your tractor or performing any adjustments or repairs. We recommend a wide vision safety mask over spectacles or standard safety glasses.

HOW TO USE YOUR TRACTOR TO SET PARKING BRAKE

Your tractor is equipped with an operator presence sensing switch. When engine is running, any attempt by the operator to leave the seat without first setting the parking brake will shut off the engine.

1. Depress clutch/brake pedal into full "BRAKE" position and hold.
2. Place parking brake lever in "ENGAGED" position and release pressure from clutch/brake pedal. Pedal should remain in "BRAKE" position. Make sure parking brake will hold tractor secure.

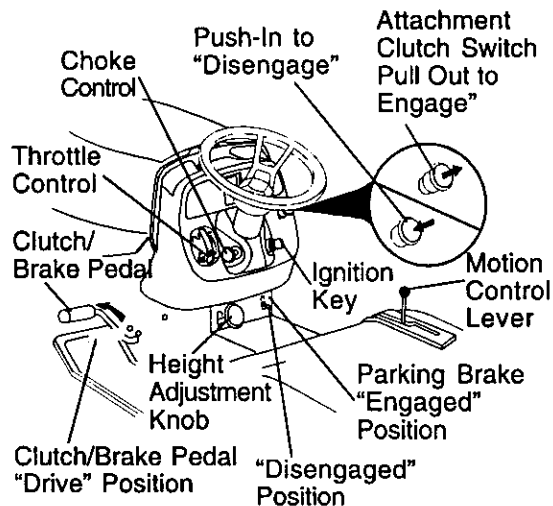

STOPPING

MOWER BLADES -

- To stop mower blades, move attachment clutch switch to "DISENGAGED" position.

GROUND DRIVE -

- To stop ground drive, depress clutch/brake pedal into full "BRAKE" position.
- Move motion control lever to neutral (N) position.

IMPORTANT: The motion control lever does not return to neutral (N) position when the clutch/brake pedal is depressed.

ENGINE -

- Move throttle control to slow position.
- NOTE:** Failure to move throttle control to slow position and allowing engine to idle before stopping may cause engine to "backfire".

- Turn ignition key to "OFF" position and remove key. Always remove key when leaving tractor to prevent unauthorized use.
 - Never use choke to stop engine.
- IMPORTANT:** Leaving the ignition switch in any position other than "OFF" will cause the battery to be discharged, (dead).

NOTE: Under certain conditions when tractor is standing idle with the engine running, hot engine exhaust gases may cause "browning" of grass. To eliminate this possibility, always stop engine when stopping tractor on grass areas.

CAUTION: Always stop tractor completely, as described above, before leaving the operator's position; to empty grass catcher, etc.

TO USE THROTTLE CONTROL

Always operate engine at full throttle.

- Operating engine at less than full throttle reduces the battery charging rate.
- Full throttle offers the best bagging and mower performance.

TO USE CHOKE CONTROL

Use choke control whenever you are starting a cold engine. Do not use to start a warm engine.

- To engage choke control, pull knob out. Slowly push knob in to disengage.

TO MOVE FORWARD AND BACKWARD

The direction and speed of movement is controlled by the motion control lever.

1. Start tractor with motion control lever in neutral (N) position.
2. Release parking brake and clutch/brake pedal.
3. Slowly move motion control lever to desired position.

TO ADJUST MOWER CUTTING HEIGHT

The cutting height is controlled by turning the height adjustment knob in desired direction.

- Turn knob clockwise (↻) to raise cutting height.
- Turn knob counterclockwise (↺) to lower cutting height.

The cutting height range is approxi-

mately 1-1/2" to 4". The heights are measured from the ground to the blade tip with the engine not running. These heights are approximate and may vary depending upon soil conditions, height of grass and types of grass being mowed.

- The average lawn should be cut to approximately 2-1/2 inches during the cool season and to over 3 inches during hot months. For healthier and better looking lawns, mow often and after moderate growth.
- For best cutting performance, grass over 6 inches in height should be mowed twice. Make the first cut relatively high; the second to desired height.

TO ADJUST GAUGE WHEELS

Gauge wheels are properly adjusted when they are slightly off the ground when mower is at the desired cutting height in operating position. Gauge wheels then keep the deck in proper position to help prevent scalping in most terrain conditions.

NOTE: Be sure tractor is on a flat level surface.

1. Lower mower and adjust mower to desired cutting height.
2. Remove retainer spring and clevis pin which secure each gauge wheel bar.
3. Lower gauge wheels to ground. Raise gauge wheels slightly to align holes in bracket and gauge wheel bar and insert clevis pin. Gauge wheels should be slightly off the ground.
4. Replace retainer spring into clevis pin.
5. Be sure all gauge wheels are in the same setting.

IMPORTANT: Be sure to readjust gauge wheels if you change the cutting height of the mower deck.

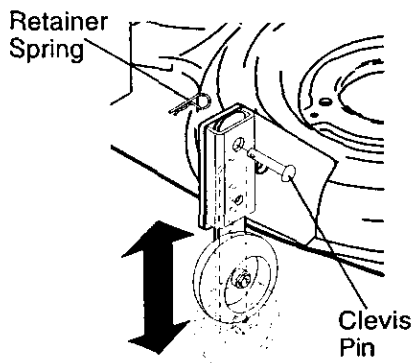

TO OPERATE MOWER

Your tractor is equipped with an operator presence sensing switch. Any attempt by the operator to leave the seat with the engine running and the attachment clutch engaged will shut off the engine.

1. Select desired height of cut.
2. Lower mower with attachment lift control.
3. Start mower blades by engaging attachment clutch control.

TO STOP MOWER BLADES - disengage attachment clutch control.

CAUTION: Do not operate the mower without either the entire grass catcher, on mowers so equipped, or the deflector shield in place.

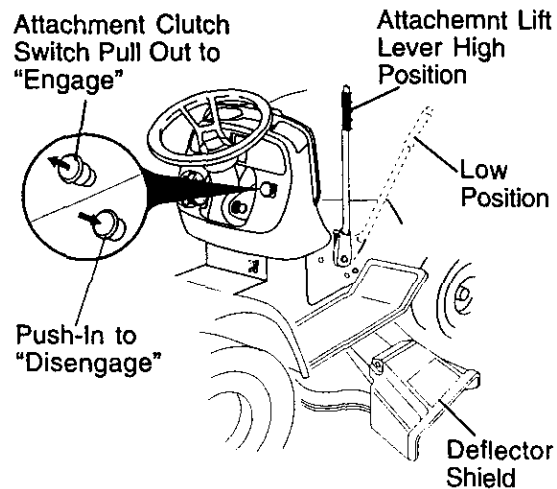

TO OPERATE ON HILLS

CAUTION: Do not drive up or down hills with slopes greater than 15° and do not drive across any slope.

- Choose the slowest speed before starting up or down hills.
- Avoid stopping or changing speed on hills.
- If slowing is necessary, move throttle control lever to slower position.
- If stopping is absolutely necessary, push clutch/brake pedal quickly to brake position and engage parking brake.
- Move motion control lever to slowest setting.

IMPORTANT: The motion control lever does not return to neutral (N) position when the clutch/brake pedal is depressed.

- To restart movement, slowly release parking brake and clutch/brake pedal.
- Slowly move motion control lever to slowest setting.
- Make all turns slowly.

TO TRANSPORT

When pushing or towing your tractor, be sure to disengage transmission by placing freewheel control in freewheeling position. Free wheel control is located at the rear drawbar of tractor.

1. Raise attachment lift to highest position with attachment lift control.
 2. Remove retainer spring from free-wheel control rod.
 3. Push control rod in to disengage transmission and reinsert retainer spring into control rod hole now on back side of the bracket.
- Do not push or tow tractor at more than two (2) MPH.
 - To reengage transmission, reverse above procedure.

NOTE: To protect hood from damage when transporting your tractor on a truck or a trailer, be sure hood is closed and secured to tractor. Use an appropriate means of tying hood to tractor (rope, cord, etc.).

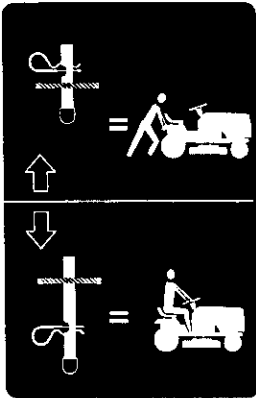

TOWING CARTS AND OTHER ATTACHMENTS

Tow only the attachments that are recommended by and comply with specifications of the manufacturer of your tractor. Use common sense when towing. Too heavy of a load, while on a slope, is dangerous. Tires can lose traction with the ground and cause you to lose control of your tractor.

BEFORE STARTING THE ENGINE CHECK ENGINE OIL LEVEL

The engine in your tractor has been shipped, from the factory, already filled with summer weight oil.

1. Check engine oil with tractor on level ground.

2. Unthread and remove oil fill cap/dipstick; wipe oil off. Reinsert the dipstick into the tube and rest oil fill cap on the tube. Do not thread the cap onto the tube. Remove and read oil level. If necessary, add oil until "FULL" mark on dipstick is reached. Do not overfill.
- For cold weather operation you should change oil for easier starting (See "OIL VISCOSITY CHART" in the Maintenance section of this manual).
 - To change engine oil, see the Maintenance section in this manual.

CHECK COOLANT LEVEL

CAUTION: Check coolant level at reservoir only. Do not open radiator cap.

- Check coolant with tractor on level surface.
1. Unhook the four retaining straps and remove the upper blower housing and screen assembly.
 2. Observe coolant reservoir. Coolant should be between the "MAX" and "MIN" level marks.
- CAUTION:** Do not pour coolant into a hot engine or you may damage the cylinder head or block. Do not operate the engine without coolant.
3. If necessary, add coolant by removing reservoir cap. Use only ethylene glycol antifreeze and soft water in the mixture ratio specified on the antifreeze container.
 4. Replace reservoir cap.
 5. Reinstall the upper blower housing and screen assembly.

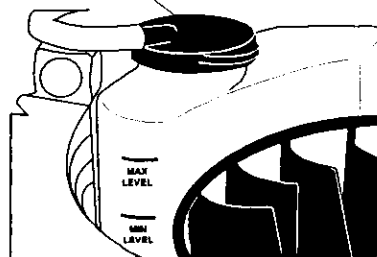
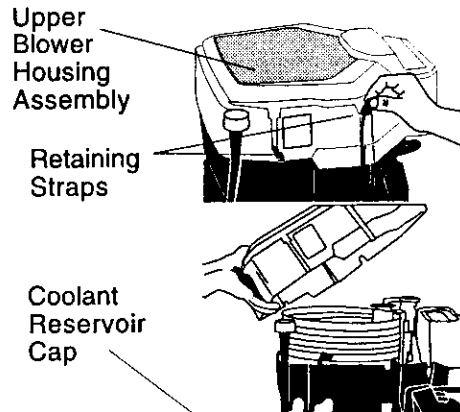

ADD GASOLINE

- Fill fuel tank. Use fresh, clean, regular unleaded gasoline with a minimum of 87 octane. (Use of leaded gasoline will increase carbon and lead oxide deposits and reduce valve life). Do not mix oil with gasoline. Purchase fuel in quantities that can be used within 30 days to assure fuel freshness.

IMPORTANT: When operating in temperatures below 32°F(0°C), use fresh, clean winter grade gasoline to help insure good cold weather starting.

⚠WARNING: Experience indicates that alcohol blended fuels (called gasohol or using ethanol or methanol) can attract moisture which leads to separation and formation of acids during storage. Acidic gas can damage the fuel system of an engine while in storage. To avoid engine problems, the fuel system should be emptied before storage of 30 days or longer. Drain the gas tank, start the engine and let it run until the fuel lines and carburetor are empty. Use fresh fuel next season. See Storage Instructions for additional information. Never use engine or carburetor cleaner products in the fuel tank or permanent damage may occur.

⚠CAUTION: Fill to bottom of gas tank filler neck. Do not overfill. Wipe off any spilled oil or fuel. Do not store, spill or use gasoline near an open flame.

OVERTEMP LIGHT

Located on the dash of your tractor, this light alerts you to the engine being overheated which requires immediate attention.

- Light should come on when engine is not running and the key switch is in "ON" position, this is a test to be sure the light is working.
- If light comes on while operating the engine, stop the engine. Find and correct the problem. See "Engine Overheats" in the Trouble Shooting section of this manual.

TO START ENGINE

When starting the engine for the first time or if the engine has run out of fuel, it will take extra cranking time to move fuel from the tank to the engine.

1. Be sure freewheel control is in the transmission engaged position.
2. Sit on seat in operating position, depress clutch/brake pedal and set parking brake.
3. Place motion control lever in neutral (N) position.

4. Move attachment clutch to "DISENGAGED" position.
5. Move throttle control to fast position
6. Pull choke control out for a cold engine start attempt. For a warm engine start attempt the choke control may not be needed.

NOTE: Before starting, read the warm and cold starting procedures below.

7. Insert key into ignition and turn key clockwise to "START" position and release key as soon as engine starts. Do not run starter continuously for more than fifteen seconds per minute. If the engine does not start after several attempts, push choke control in, wait a few minutes and try again. If engine still does not start, pull the choke control out and retry.

WARM WEATHER STARTING (50° F and above)

8. When engine starts, slowly push choke control in until the engine begins to run smoothly. If the engine starts to run roughly, pull the choke control out slightly for a few seconds and then continue to push the control in slowly.
- The attachments and ground drive can now be used. If the engine does not accept the load, restart the engine and allow it to warm up for one minute using the choke as described above.

COLD WEATHER STARTING (50° F and below)

8. When engine starts, slowly push choke control in until the engine begins to run smoothly. Continue to push the choke control in small steps allowing the engine to accept small changes in speed and load, until the choke control is fully in. If the engine starts to run roughly, pull the choke control out slightly for a few seconds and then continue to push the control in slowly. This may require an engine warm-up period from several seconds to several minutes, depending on the temperature.

AUTOMATIC TRANSMISSION WARM UP

Before driving the unit in cold weather, the transmission should be warmed up as follows:

1. Be sure the tractor is on level ground.
2. Place the motion control lever in neutral. Release the parking brake and let the clutch/brake slowly return to operating position.
3. Allow one minute for transmission to warm up. This can be done during the engine warm up period.

- The attachments can be used during the engine warm-up period after the transmission has been warmed up and may require the choke control be pulled out slightly.

NOTE: If at a high altitude (above 3000 feet) or in cold temperatures (below 32 F) the carburetor fuel mixture may need to be adjusted for best engine performance. See "TO ADJUST CARBURETOR" in the Service and Adjustments section of this manual.

PURGE TRANSMISSION

CAUTION: Never engage or disengage freewheel lever while the engine is running. To ensure proper operation and performance, it is recommended that the transmission be purged before operating tractor for the first time. This procedure will remove any trapped air inside the transmission which may have developed during shipping of your tractor.

IMPORTANT: Should your transmission require removal for service or replacement, it should be purged after reinstallation before operating the tractor.

1. Place tractor safely on level surface with engine off and parking brake set.
2. Disengage transmission by placing freewheel control in freewheeling position (See "TO TRANSPORT" in this section of manual).
3. Sitting in the tractor seat, start engine. After the engine is running, move throttle control to slow position. With motion control lever in neutral (N) position, slowly disengage clutch/brake pedal.
4. Move motion control lever to full forward position and hold for five (5) seconds. Move lever to full reverse position and hold for five (5) seconds. Repeat this procedure three (3) times.

NOTE: During this procedure there will be no movement of drive wheels. The air is being removed from hydraulic drive system.

5. Move motion control lever to neutral (N) position. Shut-off engine and set parking brake.
6. Engage transmission by placing freewheel control in driving position (See "TO TRANSPORT" in this section of manual).
7. Sitting in the tractor seat, start engine. After the engine is running, move throttle control to half (1/2) speed. With motion control lever in neutral (N) position, slowly disengage clutch/brake pedal.

8. Slowly move motion control lever forward, after the tractor moves approximately five (5) feet, slowly move motion control lever to reverse position. After the tractor moves approximately five (5) feet return the motion control lever to the neutral (N) position. Repeat this procedure with the motion control lever three (3) times.

Your tractor is now purged and now ready for normal operation.

MOWING TIPS

- Tire chains cannot be used when the mower housing is attached to tractor.
- Mower should be properly leveled for best mowing performance. See "TO LEVEL MOWER HOUSING" in the Service and Adjustments section of this manual.
- The left hand side of mower should be used for trimming.
- Drive so that clippings are discharged onto the area that has been cut. Have the cut area to the right of the tractor. This will result in a more even distribution of clippings and more uniform cutting.
- When mowing large areas, start by turning to the right so that clippings will discharge away from shrubs, fences, driveways, etc. After one or two rounds, mow in the opposite direction making left hand turns until finished.

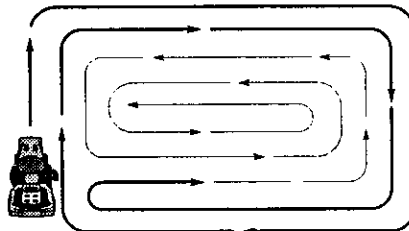

- If grass is extremely tall, it should be mowed twice to reduce load and possible fire hazard from dried clippings. Make first cut relatively high; the second to the desired height.
- Do not mow grass when it is wet. Wet grass will plug mower and leave undesirable clumps. Allow grass to dry before mowing.
- **Always operate engine at full throttle when mowing** to assure better mowing performance and proper discharge of material. Regulate ground speed by selecting a low enough gear to give the mower cutting performance as well as the quality of cut desired.
- When operating attachments, select a ground speed that will suit the terrain and give best performance of the attachment being used.

MAINTENANCE

MAINTENANCE SCHEDULE		FILL IN DATES AS YOU COMPLETE REGULAR SERVICE									
		BEFORE EACH USE	EVERY 8 HOURS	EVERY 25 HOURS	EVERY 50 HOURS	EVERY 100 HOURS	EVERY 1000 HOURS	EVERY SEASON	BEFORE STORAGE	SERVICE DATES	
T R A C T O R	Check Brake Operation	✓	✓								
	Check Tire Pressure	✓	✓								
	Check Operator Presence and Interlock Systems	✓									
	Check for Loose Fasteners	✓				✓ ₇		✓			
	Sharpen/Replace Mower Blades			✓ ₁							
	Lubrication Chart			✓				✓			
	Check Battery Level			✓ ₆							
	Clean Battery and Terminals			✓				✓			
	Check Transaxle Cooling			✓							
	Adjust Blade Belt(s) Tension					✓ ₅					
Adjust Motion Drive Belt(s) Tension					✓ ₅						
E N G I N E	Check Engine Oil Level	✓	✓								
	Change Engine Oil			✓ _{1,2,3}				✓			
	Clean Air Filter			✓ ₂							
	Clean Air Screen			✓ ₂							
	Inspect Muffler/Spark Arrester				✓						
	Replace Oil Filter (If equipped)					✓ _{1,2}					
	Clean Engine Cooling Fins					✓ ₂					
	Replace Spark Plug					✓		✓			
	Replace Air Filter Paper Cartridge					✓ ₂					
	Replace Fuel Filter							✓			
Change Coolant							✓ ₈				

- 1 - Change more often when operating under a heavy load or in high ambient temperatures.
 2 - Service more often when operating in dirty or dusty conditions.
 3 - If equipped with oil filter, change oil every 50 hours.
 4 - Replace blades more often when mowing in sandy soil.
 5 - If equipped with adjustable system.
 6 - Not required if equipped with maintenance-free battery.
 7 - Tighten front axle pivot bolt to 35 ft.-lbs. maximum. Do not overtighten.
 8 - Have your nearest authorized service center/department perform this service.

GENERAL RECOMMENDATIONS

The warranty on this tractor does not cover items that have been subjected to operator abuse or negligence. To receive full value from the warranty, operator must maintain tractor as instructed in this manual. Some adjustments will need to be made periodically to properly maintain your tractor.

All adjustments in the Service and Adjustments section of this manual should be checked at least once each season.

- Once a year you should replace the spark plug, clean or replace air filter, and check blades and belts for wear. A new spark plug and clean air filter assure proper air-fuel mixture and help your engine run better and last longer.

BEFORE EACH USE

- Check engine oil level.
- Check coolant level.
- Check brake operation.
- Check tire pressure.
- Check operator presence and interlock systems for proper operation.
- Check for loose fasteners.

LUBRICATION CHART

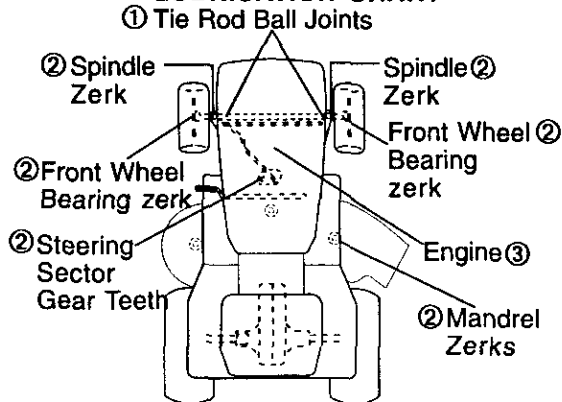

- ① Spray Silicone Lubricant (Move Boots to Lubricate)
- ② General Purpose Grease
- ③ Refer to Maintenance "ENGINE" Section

IMPORTANT: Do not oil or grease the pivot points which have special nylon bearings. Viscous lubricants will attract dust and dirt that will shorten the life of the self-lubricating bearings. If you feel they must be lubricated, use only a dry, powdered graphite type lubricant sparingly.

TRACTOR

Always observe safety rules when performing any maintenance.

BRAKE OPERATION

If tractor requires more than six (6) feet stopping distance at high speed in highest gear, then brake must be adjusted. (See "TO ADJUST BRAKE" in the Service and Adjustments section of this manual).

TIRES

- Maintain proper air pressure in all tires (See "PRODUCT SPECIFICATIONS" section of this manual).
- Keep tires free of gasoline, oil, or insect control chemicals which can harm rubber.
- Avoid stumps, stones, deep ruts, sharp objects and other hazards that may cause tire damage.

NOTE: To seal tire punctures and prevent flat tires due to slow leaks, tire sealant may be purchased from your local parts dealer. Tire sealant also prevents tire dry rot and corrosion.

OPERATOR PRESENCE SYSTEM

Be sure operator presence and interlock systems are working properly. If your tractor does not function as described, repair the problem immediately.

- The engine should not start unless the clutch/brake pedal is fully depressed and attachment clutch control is in the disengaged position.
- When the engine is running, any attempt by the operator to leave the seat without first setting the parking brake should shut off the engine.
- When the engine is running and the attachment clutch is engaged, any attempt by the operator to leave the seat should shut off the engine.
- The attachment clutch should never operate unless the operator is in the seat.

BLADE CARE

For best results mower blades must be kept sharp. Replace bent or damaged blades.

BLADE REMOVAL

1. Raise mower to highest position to allow access to blades.

NOTE: Protect your hands with gloves and/or wrap blade with heavy cloth.

2. Remove blade bolt by turning counterclockwise.

3. Install new or resharpened blade with stamped "THIS SIDE UP" facing deck and mandrel assembly.

IMPORTANT: To ensure proper assembly, center hole in blade must align with star on mandrel assembly.

4. Install and tighten blade bolt securely (45-55 Ft. Lbs. torque).

IMPORTANT: Special blade bolt is heat treated.

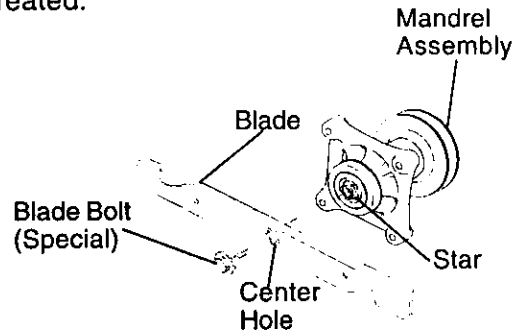

TO SHARPEN BLADE

NOTE: We do not recommend sharpening blade - but if you do, be sure the blade is balanced.

Care should be taken to keep the blade balanced. An unbalanced blade will cause excessive vibration and eventual damage to mower and engine.

- The blade can be sharpened with a file or on a grinding wheel. Do not attempt to sharpen while on the mower.
- To check blade balance, you will need a 5/8" diameter steel bolt, pin, or a cone balancer. (When using a cone balancer, follow the instructions supplied with balancer.)

NOTE: Do not use a nail for balancing blade. The lobes of the center hole may appear to be centered, but are not.

- Slide blade on to an unthreaded portion of the steel bolt or pin and hold the bolt or pin parallel with the ground. If blade is balanced, it should remain in a horizontal position. If either end of the blade moves downward, sharpen the heavy end until the blade is balanced.

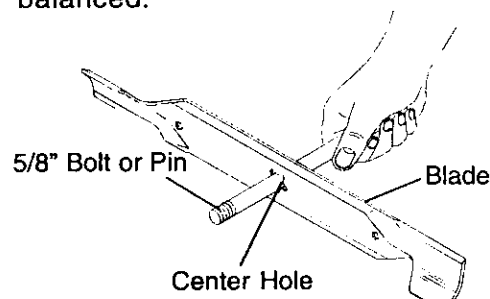

BATTERY

Your tractor has a battery charging system which is sufficient for normal use. However, periodic charging of the battery with an automotive charger will extend its life.

- Keep battery and terminals clean.
- Keep battery bolts tight.
- Keep small vent holes open.
- Recharge at 6-10 amperes for 1 hour.

NOTE: The original equipment battery on your tractor is maintenance free. Do not attempt to open or remove caps or covers. Adding or checking level of electrolyte is not necessary.

TO CLEAN BATTERY AND TERMINALS

Corrosion and dirt on the battery and terminals can cause the battery to "leak" power.

1. Remove terminal guard.
2. Disconnect BLACK battery cable first then RED battery cable and remove battery from tractor.
3. Rinse the battery with plain water and dry.
4. Clean terminals and battery cable ends with wire brush until bright.
5. Coat terminals with grease or petroleum jelly.
6. Reinstall battery (See "REPLACING BATTERY" in the SERVICE AND ADJUSTMENTS section of this manual).

V-BELTS

Check V-belts for deterioration and wear after 100 hours of operation and replace if necessary. The belts are not adjustable. Replace belts if they begin to slip from wear.

TRANSAXLE COOLING

The transmission fan and cooling fins should be kept clean to assure proper cooling.

Do not attempt to clean fan or transmission while engine is running or while the transmission is hot. To prevent possible damage to seals, do not use high pressure water or steam to clean transaxle.

- Inspect cooling fan to be sure fan blades are intact and clean.
- Inspect cooling fins for dirt, grass clippings and other materials. To prevent damage to seals, do not use compressed air or high pressure sprayer to clean cooling fins.

TRANSAXLE PUMP FLUID

The transaxle was sealed at the factory and fluid maintenance is not required for the life of the transaxle. Should the transaxle ever leak or require servicing, contact your nearest authorized service center/department.

ENGINE

LUBRICATION

Only use high quality detergent oil rated with API service classification SF-SJ. Select the oil's SAE viscosity grade according to your expected operating temperature.

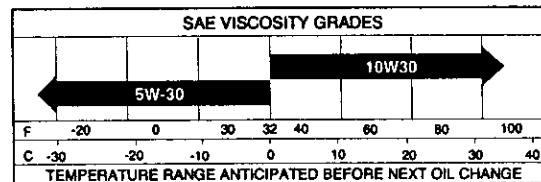

Change the oil after every 50 hours of operation or at least once a year if the tractor is not used for 50 hours in one year.

Check the crankcase oil level before starting the engine and after each eight (8) hours of operation. Tighten oil fill cap/dipstick securely each time you check the oil level.

TO CHANGE ENGINE OIL

Determine temperature range expected before oil change. All oil must meet API service classification SF-SJ.

- Be sure tractor is on level surface.
 - Oil will drain more freely when warm.
 - Catch oil in a suitable container.
1. Remove oil fill cap/dipstick. Be careful not to allow dirt to enter the engine when changing oil.
 2. Remove yellow cap from bottom fitting of drain plug and install the drain tube onto the fitting.

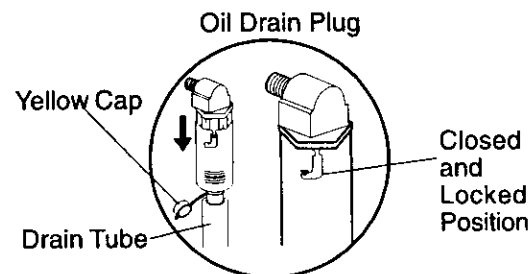

3. Unlock drain plug by pushing upward and turning counterclockwise.
4. To open, pull down on the drain plug.

5. After oil has drained completely, close and lock the drain plug by pushing upward and turning clockwise until the pin is in the locked position as shown.
6. Remove the drain tube and replace the cap onto to the bottom fitting of the drain plug.
7. Refill engine with oil through oil fill dipstick tube. Pour slowly. Do not overfill. For approximate capacity see "PRODUCT SPECIFICATIONS" section of this manual.
8. Use gauge on oil fill cap/dipstick for checking level. Insert dipstick into the tube and rest the oil fill cap on the tube. Do not thread the cap onto the tube when taking reading. Keep oil at "FULL" line on dipstick. Tighten cap onto the tube securely when finished.

ENGINE OIL FILTER

Replace the engine oil filter every season or every other oil change if the tractor is used more than 100 hours in one year.

AIR FILTER

Your engine will not run properly using a dirty air filter. Clean the foam pre-cleaner after every 25 hours of operation or every season. Service paper cartridge every 100 hours of operation or every season, whichever occurs first. Service air cleaner more often under dusty conditions.

1. Unhook the four retaining straps and remove the upper blower housing and screen assembly.

TO SERVICE PRE-CLEANER

2. Slide foam pre-cleaner off cartridge.
3. Wash it in liquid detergent and water.
4. Squeeze it dry in a clean cloth. Allow it to dry.
5. Saturate it in engine oil. Wrap it in clean, absorbent cloth and squeeze to remove excess oil.

TO SERVICE CARTRIDGE

- Replace a dirty, bent, or damaged cartridge.

NOTE: Do not wash the paper cartridge or use pressurized air, as this will damage the cartridge.

6. Unhook the cartridge retaining strap and remove the cartridge.
7. Install new cartridge and secure with retaining strap.
8. Reinstall the pre-cleaner (cleaned and oiled) over the paper cartridge.
9. Reinstall the upper blower housing and screen assembly. Secure with the four retaining straps.

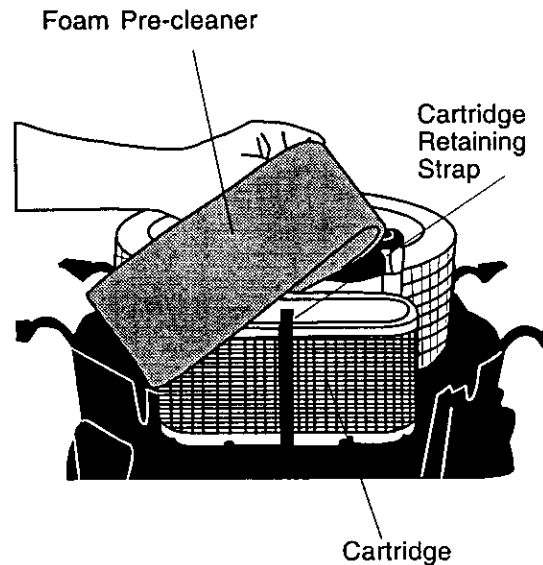

CLEAN AIR SCREEN

Air screen must be kept free of dirt and chaff to prevent engine damage from overheating. Clean with a brush or compressed air to remove dirt and stubborn dried gum fibers. If required, the screen assembly may be separated from the blower housing by unsnapping it from the underside.

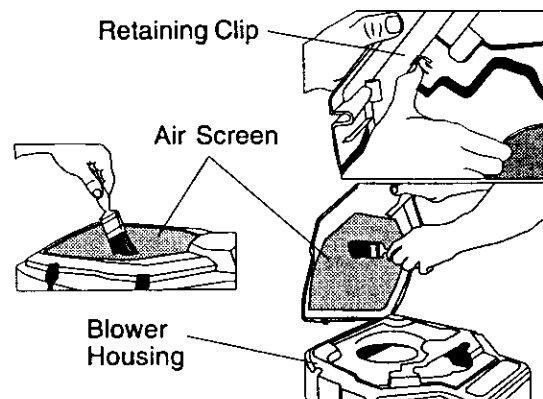

CLEAN AIR INTAKE/COOLING AREAS

To ensure proper air circulation, make sure the air intake screen, radiator, cooling fins, and other external surfaces of the engine are kept clean at all times. Every 100 hours of operation (more often under extremely dusty, dirty conditions), remove the upper blower housing assembly. Clean the cooling fins of the radiator, external surfaces, and the air intake screen and blower housing assembly as necessary. The screen assembly may be separated from the upper blower housing to permit more thorough cleaning if required (See "CLEAN AIR SCREEN"). Make sure all parts are reinstalled before starting the engine. If the screen assembly was separated from the blower housing, push the upper retaining clips into the locked position.

Clean the cooling fins of the radiator with a soft brush or blow out using clean, compressed air. Do not use a high pressure washer to clean, to avoid damaging the cooling fins.

NOTE: Operating the engine with a blocked air intake screen, dirty or plugged radiator cooling fins, and/or cooling shrouds removed, will cause engine damage due to overheating.

Radiator Cooling Fins

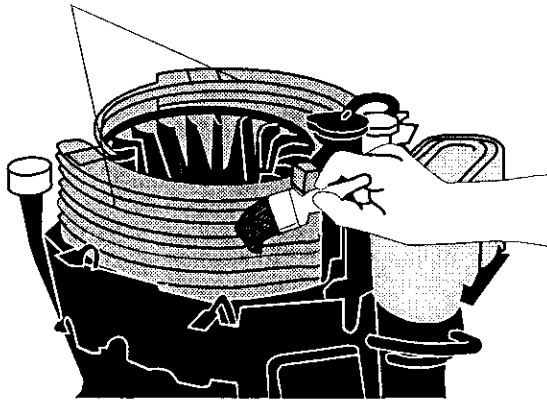

TO CHANGE RADIATOR COOLANT

1. Stop engine and allow it to cool sufficiently.
2. Unhook the four retaining straps and remove the upper blower housing and screen assembly.
3. Check if the radiator is cool to the touch. Slowly loosen the radiator cap to the first stop and allow any pressure to bleed off. Then loosen the cap fully and remove.

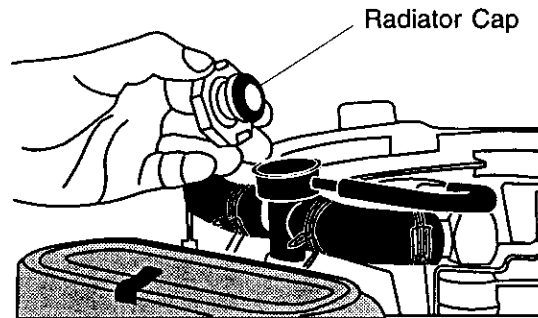

4. Locate and remove the coolant drain plug on the lower side of both cylinder heads. Drain the coolant into a suitable container.
5. After the coolant has drained, apply pipe sealant with Teflon (not Teflon tape) to the threads and reinstall the plugs. Tighten the plugs to 120 in. lbs. Torque.
6. The coolant reservoir has three (3) molded protrusions (1 upper and 2 lower) that fit into corresponding holes in the support brackets. Loosen the screws that secure the upper bracket to the radiator enough to allow the reservoir to be removed.
7. Remove the reservoir cap. Carefully tip the bracket away from the reservoir and lift the reservoir out.

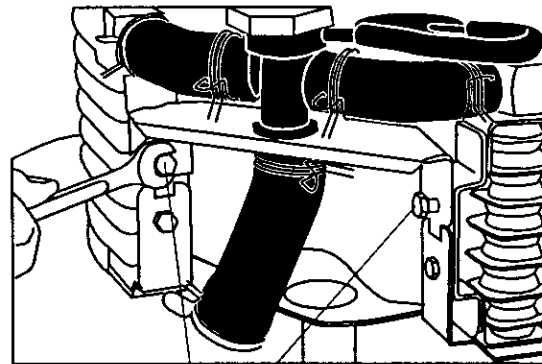

Loosen Screws

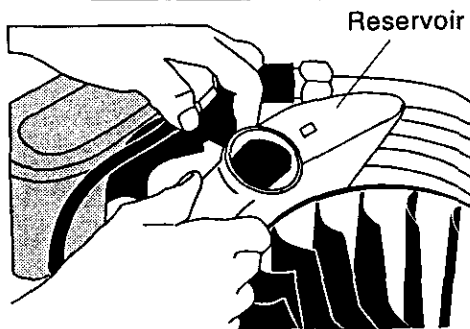
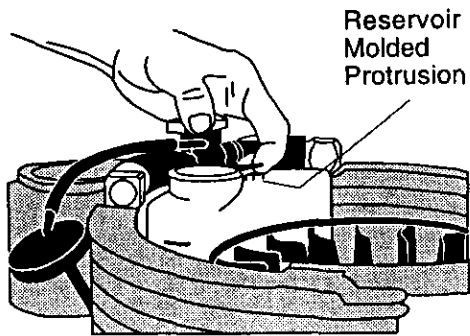

8. Pour out the contents of the reservoir and wash out or clean as required.
9. Dispose of all the old coolant properly, according to local regulations.
10. Reinstall the reservoir, engaging the molded protrusions in the mounting holes of the support brackets. Hold in this position and tighten the upper bracket screws securely.
11. Check the condition of cooling system hoses, clamps and associated components. Replace as required.
12. Mix equal parts of ethylene glycol anti-freeze and distilled water. For approximate engine coolant capacity, see "PRODUCT SPECIFICATIONS" in the front of this manual.
13. Fill the cooling system through the neck for radiator cap with the coolant mixture. Allow coolant to drain into the lower areas of engine. Fill the overflow reservoir to a level between the "MAX" and "MIN" level marks. Reinstall the radiator and reservoir caps.
14. Reinstall the upper blower housing and screen assembly.
15. Start and run the engine for five minutes. Stop the engine and allow it to cool.
16. Remove the upper blower housing and recheck the coolant level. Add coolant to reservoir only if necessary.
17. Reinstall the upper blower housing and screen assembly. Secure with the retaining straps.

MUFFLER

Inspect and replace corroded muffler and spark arrester (if equipped) as it could create a fire hazard and/or damage.

SPARK PLUGS

Replace spark plugs at the beginning of each mowing season or after every 100 hours of operation, whichever occurs first. Spark plug type and gap setting are shown in "PRODUCT SPECIFICATIONS" section of this manual.

IN-LINE FUEL FILTER

The fuel filter should be replaced once each season. If fuel filter becomes clogged, obstructing fuel flow to carburetor, replacement is required.

1. With engine cool, remove filter and plug fuel line sections.
2. Place new fuel filter in position in fuel line with arrow pointing towards carburetor.
3. Be sure there are no fuel line leaks and clamps are properly positioned.
4. Immediately wipe up any spilled gasoline.

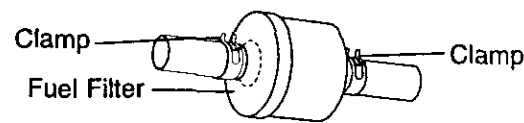

CLEANING

- Clean engine, battery, seat, finish, etc. of all foreign matter.
- Keep finished surfaces and wheels free of all gasoline, oil, etc.
- Protect painted surfaces with automotive type wax.

We do not recommend using a garden hose to clean your tractor unless the electrical system, muffler, air filter and carburetor are covered to keep water out. Water in engine can result in a shortened engine life.

SERVICE AND ADJUSTMENTS

CAUTION: Before performing any service or adjustments:

1. Depress clutch/brake pedal fully and set parking brake.
2. Place motion control lever in neutral (N) position.
3. Place attachment clutch in "DISENGAGED" position.
4. Turn ignition key "OFF" and remove key.
5. Make sure the blades and all moving parts have completely stopped.
6. Disconnect spark plug wire from spark plug and place wire where it cannot come in contact with plug.

TRACTOR

TO REMOVE MOWER

1. Place attachment clutch in "DISENGAGED" position.
2. If equipped, turn height adjustment knob to lowest setting.
3. Lower mower to its lowest position.
4. Disengage belt tension rod from lock bracket.

CAUTION: Rod is spring loaded. Have a tight grip on rod and release slowly.

5. Remove retainer spring holding anti-swaybar to chassis bracket and disengage anti-swaybar from bracket.
6. Remove four retainer springs from front plate assembly and remove plate.
7. Remove retainer springs from suspension arms at deck and disengage arms from deck.
8. Raise attachment lift to its highest position.
9. Slide mower forward and remove belt from electric clutch pulley.
10. Slide mower out from under right side of tractor.

TO INSTALL MOWER

Follow procedure described in "INSTALL MOWER AND DRIVE BELT" in the Assembly section of this manual.

TO LEVEL MOWER HOUSING

Adjust the mower while tractor is parked on level ground or driveway. Make sure tires are properly inflated (See "PRODUCT SPECIFICATIONS" section of this manual). If tires are over or underinflated, you will not properly adjust your mower.

SIDE-TO-SIDE ADJUSTMENT

- Raise mower to its highest position.
- Measure height from bottom edge of mower to ground level at front corners of mower. Distance "A" on both sides of mower should be the same.
- If adjustment is necessary, make adjustment on one side of mower only.
- To raise one side of mower, tighten lift link adjustment nut on that side.
- To lower one side of mower, loosen lift link adjustment nut on that side.

NOTE: Each full turn of adjustment nut will change mower height about 3/16".

- Recheck measurements after adjusting.

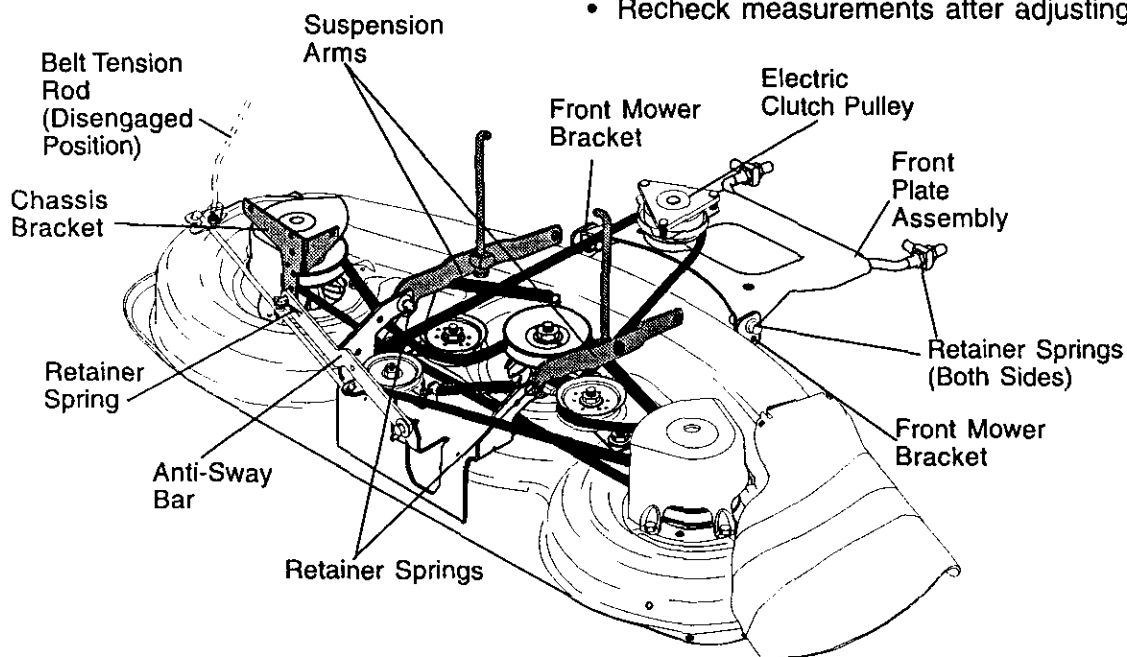

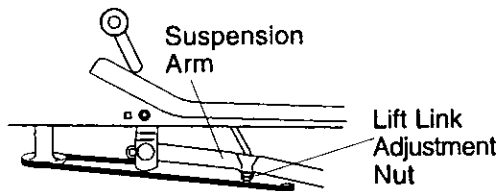
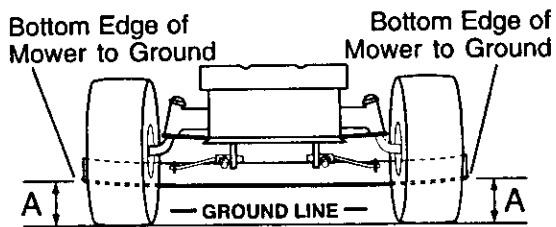

FRONT-TO-BACK ADJUSTMENT

IMPORTANT: Deck must be level side-to-side. If the following front-to-back adjustment is necessary, be sure to adjust both front links equally so mower will stay level side-to-side.

To obtain the best cutting results, the mower blades should be adjusted so the front tip is approximately 1/8" to 1/2" lower than the rear tip when the mower is in its highest position.

CAUTION: Blades are sharp. Protect your hands with gloves and/or wrap blade with heavy cloth. Check adjustment on right side of tractor. Position any blade so the tip is pointing straight forward. Measure distance "B" at front and rear tip of blade

- Before making any necessary adjustments, check that both front links are equal in length.
- If links are not equal in length, adjust one link to same length as other link.
- To lower front of blade, loosen nut "C" on both front links an equal number of turns.

NOTE: Each full turn of nut "C" will change dim. "B" by approximately 3/16".

- When distance "B" is 1/8" to 1/2" lower at front than rear, tighten nut "D" against trunnion on both front links.
- To raise front of blade, loosen nut "D" from trunnion on both front links. Tighten nut "C" on both front links an equal number of turns.
- When distance "B" is 1/8" to 1/2" lower at front than rear, tighten nut "D" against trunnion on both front links.
- Recheck side-to-side adjustment.

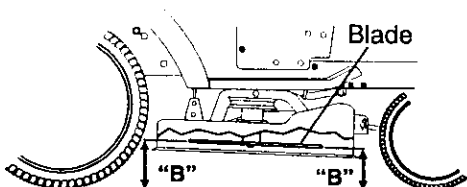

BOTH FRONT LINKS MUST BE EQUAL IN LENGTH

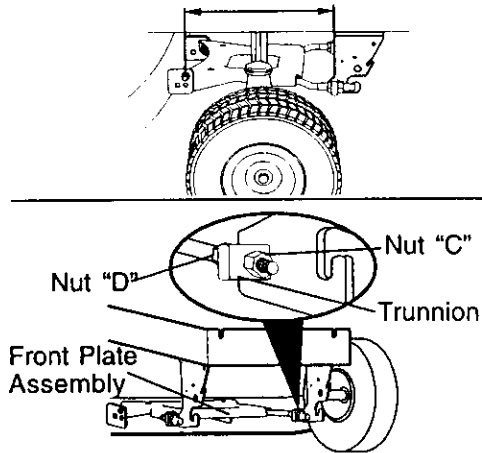

TO REPLACE MOWER DRIVE BELT

MOWER DRIVE BELT REMOVAL

1. Park tractor on a level surface. Engage parking brake.
2. Lower mower to its lowest position.
3. Disengage belt tension rod from lock bracket.

CAUTION: Rod is spring loaded. Have a firm grip on rod and release slowly.

4. Remove screws from R.H. mandrel cover and remove cover.
5. Remove any dirt or grass clippings which may have accumulated around mandrels and entire upper deck surface.
6. Disconnect R.H. suspension arm from rear deck bracket by removing retainer spring.
7. Carefully roll belt over the top of R.H. mandrel pulley.
8. Remove belt from electric clutch pulley.
9. Remove belt from idler pulleys.
10. Check primary idler arm and two idlers to see that they rotate freely.
11. Be sure spring is securely hooked to primary idler arm and spring arm.

MOWER DRIVE BELT INSTALLATION

12. Install belt in both idlers.
13. Install new belt onto electric clutch pulley.
14. Carefully roll belt into upper groove of R.H. mandrel pulley.
15. Carefully check belt routing making sure belt is in the grooves correctly.
16. Reconnect R.H. suspension arm to rear deck bracket with retainer spring.
17. Reassemble R.H. mandrel cover.
18. Engage belt tension rod by pushing rod into locking bracket.

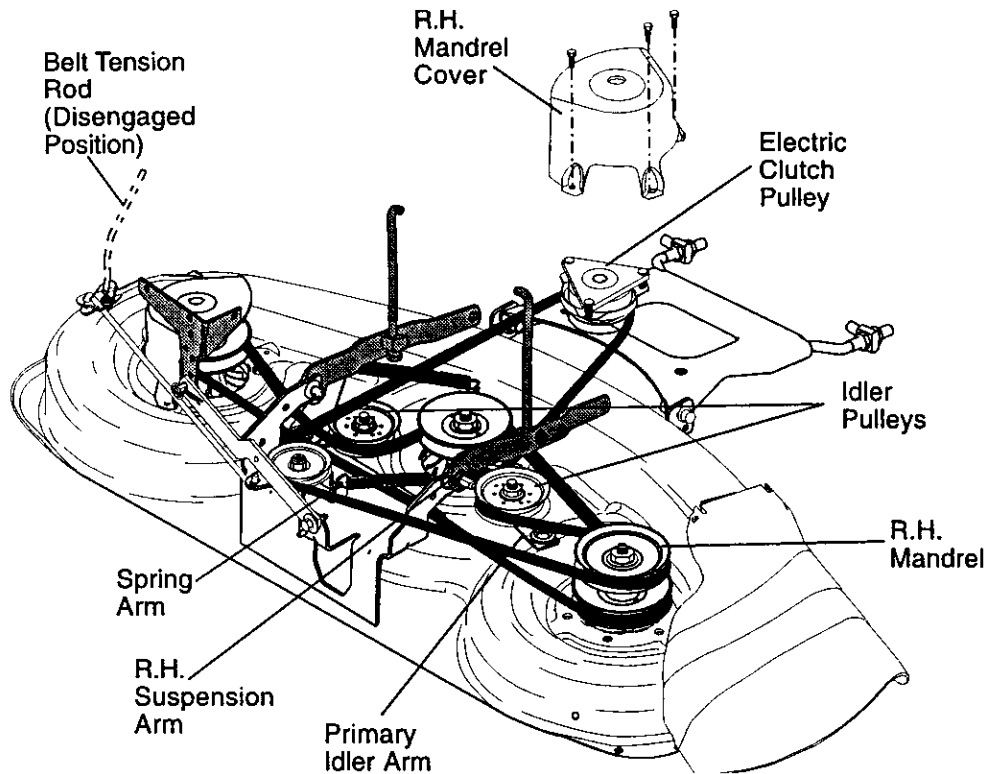

TO REPLACE MOWER BLADE DRIVE BELT

Park the tractor on level surface. Engage parking brake.

1. Remove mower drive belt (See "TO REPLACE MOWER DRIVE BELT" in this section of this manual).
2. Remove mower (See "TO REMOVE MOWER" in this section of this manual).
3. Remove screws from L.H. mandrel cover and remove cover.
4. Carefully roll belt off L.H. mandrel pulley.
5. Remove belt from center mandrel pulley, idler pulley, and R.H. mandrel pulley.
6. Remove any dirt or grass which may have accumulated around mandrels and entire upper deck surface.
7. Check secondary idler arm and idler pulley to see that they rotate freely.
8. Be sure spring is hooked in secondary idler arm and secondary spring arm.
9. Install new belt in lower groove of R.H. mandrel pulley, idler pulley, and center mandrel pulley as shown.

10. Carefully roll belt over L.H. mandrel pulley. Make sure belt is in all grooves properly.
11. Reinstall L.H. mandrel cover.
12. Reinstall mower to tractor (See "INSTALL MOWER AND DRIVE BELT" in the Assembly section of this manual).
13. Reassemble mower drive belt (See "TO REPLACE MOWER DRIVE BELT" in this section of this manual).

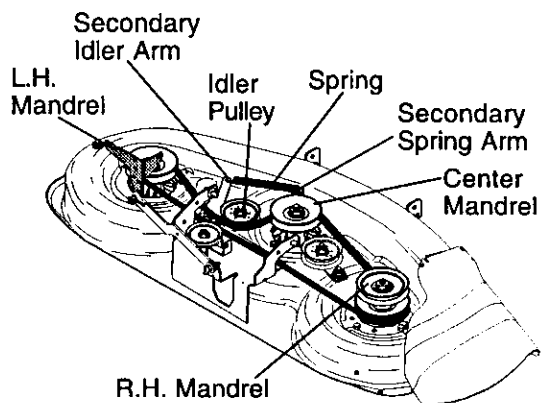

TO ADJUST ATTACHMENT CLUTCH

The electric clutch should provide years of service. The clutch has a built-in brake that stops the pulley within 5 seconds. Eventually, the internal brake will wear which may cause the mower blades to not engage, or, to not stop as required. Adjustments should be made by your nearest Sears or other qualified service center.

1. Make sure attachment clutch and ignition switches are in "OFF" position.
2. Adjust the three nylon locknuts until space between clutch plate and rotor measures .012" at all three slot locations cut in the side of brake plate.

NOTE: After installing a new electric clutch, run tractor at full throttle and engage and disengage electric clutch 10 cycles to wear in clutch plate.

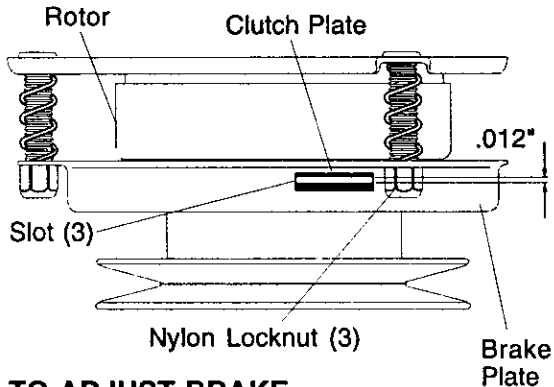

TO ADJUST BRAKE

Your tractor is equipped with an adjustable brake system which is mounted on the right side of the transaxle.

If tractor requires more than six (6) feet stopping distance at high speed in highest gear on a level dry concrete or paved surface, then brake must be adjusted

1. Depress clutch/brake pedal and engage parking brake.
2. Measure distance between brake operating arm and nut "A" on brake rod.
3. If distance is other than 1-1/2", loosen jam nut and turn nut "A" until distance becomes 1-1/2". Retighten jam nut against nut "A".
4. Road test tractor for proper stopping distance as stated above. Readjust if necessary. If stopping distance is still greater than six (6) feet in highest gear, further maintenance is necessary. Contact your nearest Sears or other qualified service center.

With Parking Brake "Engaged"

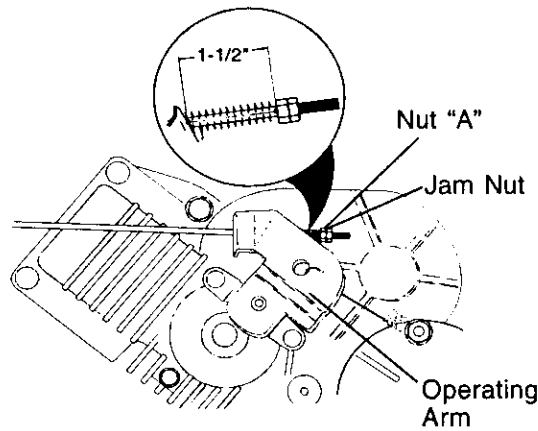

TO REPLACE MOTION DRIVE BELT

Park the tractor on level surface. Engage parking brake. For ease of service there is a belt installation guide decal on bottom of left footrest.

1. Remove mower (See "TO REMOVE MOWER" in this section of this manual.)

BELT REMOVAL -

2. Engage parking brake (creates slack in belt).
3. Remove belt from clutching and fan idler pulleys.
4. Loosen belt keeper above transaxle pulley.
5. Remove belt from transaxle pulley.
6. Remove belt from engine pulley and front V-idler pulley.
7. Pull belt out of all belt keepers and remove from tractor.

BELT INSTALLATION -

1. Place V part of belt into grooves on engine pulley and front V-idler, making sure to route belt inside of all belt keepers.
2. Route belt on right side, coming from V-idler, towards back of tractor, above midspan belt keeper and to top of transaxle pulley.
3. Route belt on left side, coming from engine pulley, towards back of tractor and through loop in midspan belt keeper.
4. Place V part of belt into grooves on transaxle and fan idler pulleys, making sure to route belt inside of all belt keepers.
5. Retighten belt keeper above transaxle pulley.
6. Place belt around clutching idlers as shown, making sure to route belt inside of all belt keepers.

7. Check to be sure belt is positioned correctly and is on proper side of all belt keepers.
 8. Reinstall mower.
- IMPORTANT:** Check brake adjustment.

**Tractor V-Belt Drive Schematic
Viewed From L.H. Side of Tractor**

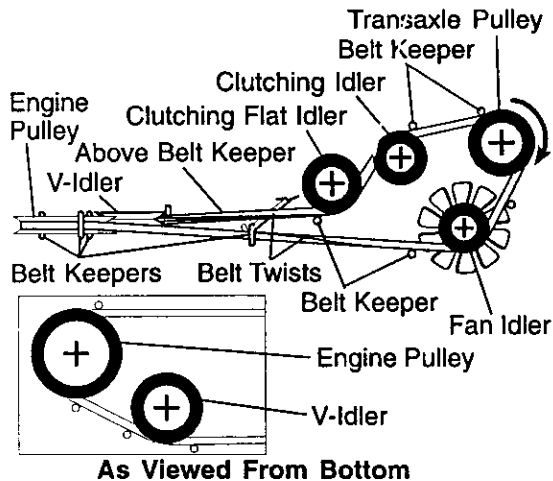

TRANSMISSION REMOVAL/REPLACEMENT

Should your transmission require removal for service or replacement, it should be purged after reinstallation and before operating the tractor. See "PURGE TRANSMISSION" in the Operation section of this manual.

TO ADJUST MOTION CONTROL LEVER

The motion control lever has been preset at the factory and adjustment should not be necessary. If for any reason the motion control lever will not hold its position while at a selected speed, it may be adjusted at the friction pack located on the right side of chassis.

1. Park tractor on level surface. Stop tractor by turning ignition key to "OFF" position and engage parking brake.
2. Place motion control lever in neutral (N) position.
3. While holding locknut, loosen jam nut
4. Tighten locknut 1/4 turn.
5. While holding locknut, tighten jam nut securely.

NOTE: If for any reason the effort to move the motion control lever becomes too excessive, reverse the above adjustment procedure by loosening locknut 1/4 turn.

Road test tractor after adjustment and repeat procedure if necessary.

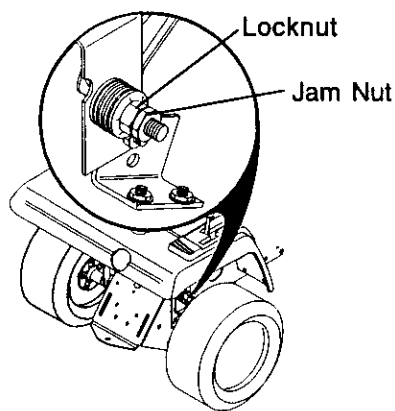

TO ADJUST STEERING WHEEL ALIGNMENT

If steering wheel crossbars are not horizontal (left to right) when wheels are positioned straight forward, remove steering wheel and reassemble per instructions in the Assembly section of this manual.

FRONT WHEEL TOE-IN ADJUSTMENT

Front wheel toe-in is required for proper steering operation. Toe-in was set at the factory and adjustment should not be necessary. If parts in the front axle or steering mechanism have been replaced or damaged, check toe-in and adjust if necessary.

TO CHECK TOE-IN

1. Position front wheels straight ahead.
 2. Measure distance between wheels at front and rear of tires (dimensions "A" and "B").
- Front dimension "A" should be 1/8" to 1/4" less than rear dimension "B".

TO ADJUST TOE-IN

1. Loosen jam nuts at adjustment sleeves on tie rod.
2. Adjust tie rod until dimension "A" is 1/8" to 1/4" less than dimension "B".
3. Tighten jam nuts securely.

FRONT WHEEL CAMBER

The front wheel camber is not adjustable on your tractor. If damage has occurred to affect the front wheel camber, contact a Sears or other qualified service center.

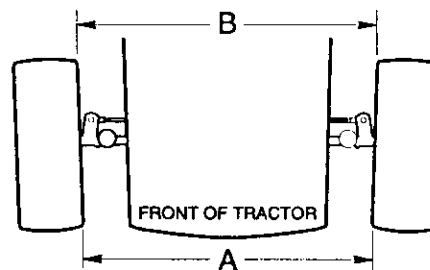

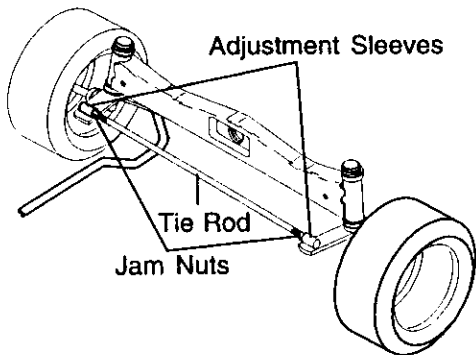

TO REMOVE WHEEL FOR REPAIRS FRONT WHEEL

1. Block up axle securely.
2. Remove axle cover, retaining ring and washers to allow wheel removal.
3. Repair tire and reassemble.
4. Replace washers and snap retaining ring securely in axle groove.
5. Replace axle cover.

REAR WHEEL

1. Block rear axle securely.
2. Remove five (5) hub bolts to allow wheel removal.
3. Repair tire and reassemble. Replace and tighten hub bolts securely.

NOTE: To seal tire punctures and prevent flat tires due to slow leaks, tire sealant may be purchased from your local parts dealer. Tire sealant also prevents tire dry rot and corrosion.

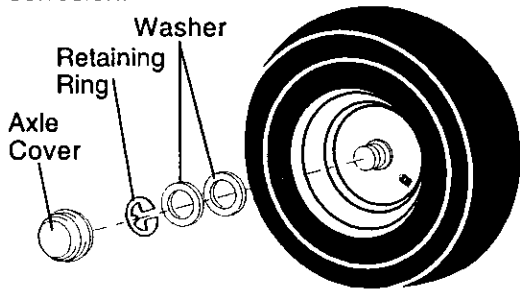

TO START ENGINE WITH A WEAK BATTERY

CAUTION: Lead-acid batteries generate explosive gases. Keep sparks, flame and smoking materials away from batteries. Always wear eye protection when around batteries.

If your battery is too weak to start the engine, it should be recharged. (See "BATTERY" in the MAINTENANCE section of this manual). If "jumper cables" are used for emergency starting, follow this procedure:

IMPORTANT: Your tractor is equipped with a 12 volt negative grounded system. The other vehicle must also be a 12 volt negative grounded system. Do not use your tractor battery to start other vehicles.

TO ATTACH JUMPER CABLES -

1. Connect each end of the RED cable to the POSITIVE (+) terminal of each battery, taking care not to short against chassis.
2. Connect one end of the BLACK cable to the NEGATIVE (-) terminal of fully charged battery.
3. Connect the other end of the BLACK cable to good CHASSIS GROUND, away from fuel tank and battery.

TO REMOVE CABLES, REVERSE ORDER -

1. BLACK cable first from chassis and then from the fully charged battery.
2. RED cable last from both batteries.

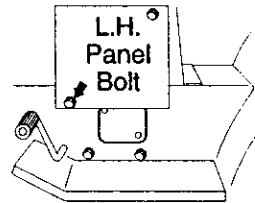
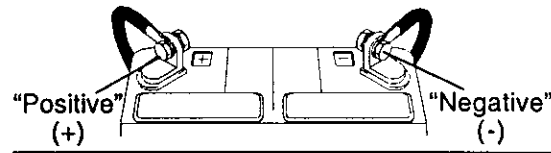

REPLACING BATTERY

CAUTION: Do not short battery terminals by allowing a wrench or any other object to contact both terminals at the same time. Before connecting battery, remove metal bracelets, wristwatch bands, rings, etc.

Positive terminal must be connected first to prevent sparking from accidental grounding.

1. Lift hood to raised position.
2. Remove terminal guard.
3. Disconnect BLACK battery cable then RED battery cable and carefully remove battery from tractor.
4. Install new battery with terminals in same position as old battery.
5. Reinstall terminal guard.
6. First connect RED battery cable to positive (+) battery terminal with hex bolt and keps nut as shown. Tighten securely.
7. Connect BLACK grounding cable to negative (-) battery terminal with remaining hex bolt and keps nut. Tighten securely
8. Close terminal access doors.
9. Close hood.

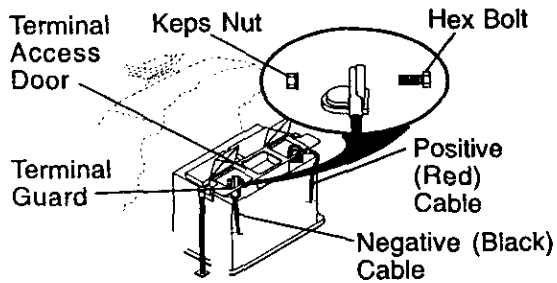

TO REPLACE HEADLIGHT BULB

1. Raise hood.
2. Pull bulb holder out of the hole in the backside of the grill.
3. Replace bulb in holder and push bulb holder securely back into the hole in the backside of the grill.
4. Close hood.

INTERLOCKS AND RELAYS

Loose or damaged wiring may cause your tractor to run poorly, stop running, or prevent it from starting.

- Check wiring. See electrical wiring diagram in the Repair Parts section.

TO REPLACE FUSE

Replace with 30 amp automotive-type plug-in fuse. The fuse holder is located behind the dash.

TO ADJUST ATTACHMENT LIFT SPRING

1. While holding spring bushing with wrench, loosen jam nut.
 - Turn adjustment bolt clockwise to extend spring and reduce lift effort for heavier attachments.
 - Turn adjustment bolt counterclockwise for lighter attachments.
2. Retighten jam nut against spring bushing.

IMPORTANT: Do not adjust for maximum spring tension when using light attachments such as a mower. Adjust lift lever spring to aid in lifting attachment. Do not overpower spring. When removing attachment, always adjust spring tension to its lowest position.

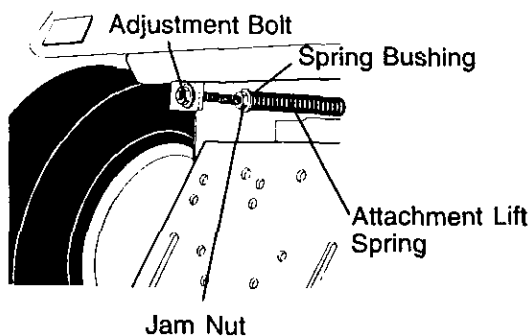

TO REMOVE HOOD AND GRILL ASSEMBLY

1. Raise hood.
2. Unsnap headlight wire connector.
3. Stand in front of tractor. Grasp hood at sides, tilt toward engine and lift off of tractor.
4. To replace, reverse above procedure.

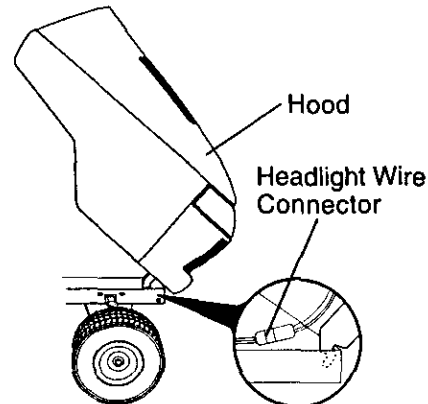

ENGINE

CARBURETOR TROUBLESHOOTING AND ADJUSTMENTS

In compliance with government emission standards, the carburetor is calibrated to deliver the correct fuel-to-air mixture to the engine under all operating conditions. The carburetor cannot be adjusted, except for low idle speed. Carburetor servicing should be performed by an authorized service center only.

TROUBLESHOOTING

If engine troubles are experienced that appear to be fuel system related, check the following areas before adjusting the carburetor.

1. Make sure the fuel tank is filled with clean, fresh gasoline.
2. Make sure the fuel tank cap vent is not blocked and that it is operating properly.
3. Make sure the in-line fuel filter is clean. Replace the filter if it is dirty or restricted.
4. Make sure fuel is reaching the carburetor. This includes checking the fuel lines and fuel pump for restrictions or faulty components.
5. Make sure the air cleaner cartridge and precleaner are clean and

properly installed.

6. Make sure the air intake screen, blower housing and cooling surfaces of radiator are clean and free of dirt and debris.
7. Make sure cooling system is filled to the proper level.

If, after checking the items listed above, the engine is hard to start, runs roughly, or stalls at low idle speed, it may be necessary to adjust or service the carburetor.

TO ADJUST LOW IDLE SPEED

1. Place the throttle control into the "slow" position. Using a tachometer set the low idle speed to 1200 RPM by turning the low idle speed adjusting screw in or out.
2. If proper operation is not restored after adjusting the low idle speed, carbure-

IMPORTANT: Never tamper with the engine governor, which is factory set for proper engine speed. Overspeeding the engine above the factory high speed setting can be dangerous. If you think the engine-governed high speed needs adjusting, contact your nearest authorized service center/department, which has proper equipment and experience to make any necessary adjustments.

Idle Speed
Adjusting Screw

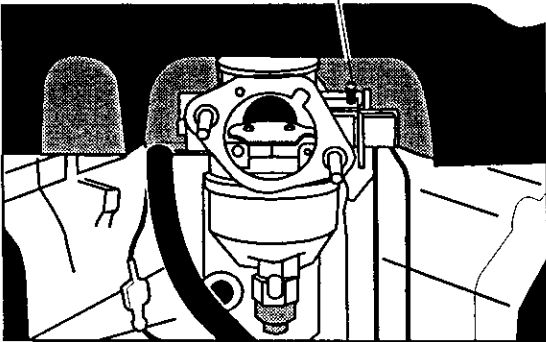

STORAGE

Immediately prepare your tractor for storage at the end of the season or if the tractor will not be used for 30 days or more.

CAUTION: Never store the tractor with gasoline in the tank inside a building where fumes may reach an open flame or spark. Allow the engine to cool before storing in any enclosure.

TRACTOR

Remove mower from tractor for winter storage. When mower is to be stored for a period of time, clean it thoroughly, remove all dirt, grease, leaves, etc. Store in a clean, dry area.

1. Clean entire tractor (See "CLEANING" in the Maintenance section of this manual).
2. Inspect and replace belts, if necessary (See belt replacement instructions in the Service and Adjustments section of this manual).
3. Lubricate as shown in the Maintenance section of this manual.
4. Be sure that all nuts, bolts and screws are securely fastened. Inspect moving parts for damage, breakage and wear. Replace if necessary.
5. Touch up all rusted or chipped paint surfaces; sand lightly before painting.

BATTERY

- Fully charge the battery for storage.
- After a period of time in storage, battery may require recharging.
- To help prevent corrosion and power leakage during long periods of storage, battery cables should be disconnected and battery cleaned thoroughly (see "TO CLEAN BATTERY AND TERMINALS" in the Maintenance section of this manual).
- After cleaning, leave cables disconnected and place cables where they cannot come in contact with battery terminals.
- If battery is removed from tractor for storage, do not store battery directly on concrete or damp surfaces.

ENGINE

FUEL SYSTEM

IMPORTANT: It is important to prevent gum deposits from forming in essential fuel system parts such as carburetor, fuel filter, fuel hose, or tank during storage. Also, experience indicates that alcohol blended fuels (called gasohol or using ethanol or methanol) can attract moisture which leads to separation and formation of acids during storage. Acidic gas can damage the fuel system of an engine while in storage.

1. Drain the fuel tank.

2. Start the engine and let it run until the fuel lines and carburetor are empty.
- Never use engine or carburetor cleaner products in the fuel tank or permanent damage may occur.
 - Use fresh fuel next season.

NOTE: Fuel stabilizer is an acceptable alternative in minimizing the formation of fuel gum deposits during storage. Add stabilizer to gasoline in fuel tank or storage container. Always follow the mix ratio found on stabilizer container. Run engine at least 10 minutes after adding stabilizer to allow the stabilizer to reach the carburetor. Do not drain the gas tank and carburetor if using fuel stabilizer.

ENGINE OIL

Drain oil (with engine warm) and replace with clean engine oil. (See "ENGINE" in the Maintenance section of this manual).

COOLANT SYSTEM

The coolant (anti-freeze) mixture should be in good condition and tested to guard against freezing in cold temperatures. The recommended equal parts mixture will normally provide protection down to temperatures of -34° F (-37° C). If storage temperatures will fall below this, the cooling system should be drained. A note should then be attached to the equipment and/or engine as a reminder to refill the cooling system before starting.

CYLINDER(S)

1. Remove spark plug(s).
2. Pour one ounce of oil through spark plug hole(s) into cylinder(s).
3. Turn ignition key to "START" position for a few seconds to distribute oil.
4. Replace with new spark plug(s).

OTHER

- Do not store gasoline from one season to another.
- Replace your gasoline can if your can starts to rust. Rust and/or dirt in your gasoline will cause problems.
- If possible, store your tractor indoors and cover it to give protection from dust and dirt.
- Cover your tractor with a suitable protective cover that does not retain moisture. Do not use plastic. Plastic cannot breathe which allows condensation to form and will cause your tractor to rust.

IMPORTANT: Never cover tractor while engine and exhaust areas are still warm.

TROUBLESHOOTING CHART

PROBLEM	CAUSE	CORRECTION
Will not start	<ol style="list-style-type: none"> 1. Out of fuel. 2. Engine not "CHOKED" properly. 3. Engine flooded. 4. Bad spark plug. 5. Dirty air filter. 6. Dirty fuel filter. 7. Water in fuel. 8. Loose or damaged wiring. 9. Carburetor out of adjustment. 10. Engine valves out of adjustment. 	<ol style="list-style-type: none"> 1. Fill fuel tank. 2. See "TO START ENGINE" in Operation section. 3. Wait several minutes before attempting to start. 4. Replace spark plug. 5. Clean/replace air filter. 6. Replace fuel filter. 7. Drain fuel tank and carburetor, refill tank with fresh gasoline and replace fuel filter. 8. Check all wiring. 9. See "To Adjust Carburetor" in Service Adjustments section. 10. Contact a Sears or other qualified service center.
Hard to start	<ol style="list-style-type: none"> 1. Dirty air filter. 2. Bad spark plug. 3. Weak or dead battery. 4. Dirty fuel filter. 5. Stale or dirty fuel. 6. Loose or damaged wiring. 7. Carburetor out of adjustment. 8. Engine valves out of adjustment. 	<ol style="list-style-type: none"> 1. Clean/replace air filter. 2. Replace spark plug. 3. Recharge or replace battery. 4. Replace fuel filter. 5. Drain fuel tank and refill with fresh gasoline. 6. Check all wiring. 7. See "To Adjust Carburetor" in Service Adjustments section. 8. Contact a Sears or other qualified service center.
Engine will not turn over	<ol style="list-style-type: none"> 1. Brake pedal not depressed 2. Attachment clutch is engaged. 3. Weak or dead battery. 4. Blown fuse. 5. Corroded battery terminals. 6. Loose or damaged wiring. 7. Faulty ignition switch. 8. Faulty solenoid or starter. 9. Faulty operator presence switch(es). 	<ol style="list-style-type: none"> 1. Depress brake pedal. 2. Disengage attachment clutch. 3. Recharge or replace battery. 4. Replace fuse. 5. Clean battery terminals. 6. Check all wiring. 7. Check/replace ignition switch. 8. Check/replace solenoid or starter. 9. Contact a Sears or other qualified service center.
Engine clicks but will not start	<ol style="list-style-type: none"> 1. Weak or dead battery. 2. Corroded battery terminals. 3. Loose or damaged wiring. 4. Faulty solenoid or starter. 	<ol style="list-style-type: none"> 1. Recharge or replace battery. 2. Clean battery terminals. 3. Check all wiring. 4. Check/replace solenoid or starter.
Loss of power	<ol style="list-style-type: none"> 1. Cutting too much grass/too fast. 2. Throttle in "CHOKE" position. 	<ol style="list-style-type: none"> 1. Set in "Higher Cut" position/reduce speed. 2. Adjust throttle control.

TROUBLESHOOTING CHART

PROBLEM	CAUSE	CORRECTION
Loss of power (continued)	<ol style="list-style-type: none"> 3. Build-up of grass, leaves and trash under mower. 4. Dirty air filter. 5. Low oil level/dirty oil. 6. Faulty spark plug. 7. Dirty fuel filter. 8. Stale or dirty fuel. 9. Water in fuel. 10. Spark plug wire loose. 11. Dirty engine air screen/fins. 12. Dirty/clogged muffler. 13. Loose or damaged wiring. 14. Carburetor out of adjustment. 15. Engine valves out of adjustment. 	<ol style="list-style-type: none"> 3. Clean underside of mower housing. 4. Clean/replace air filter. 5. Check oil level/change oil. 6. Clean and regap or change spark plug. 7. Replace fuel filter. 8. Drain fuel tank and refill with fresh gasoline. 9. Drain fuel tank and carburetor, refill tank with fresh gasoline and replace fuel filter. 10. Connect and tighten spark plug wire. 11. Clean engine air screen/fins. 12. Clean/replace muffler. 13. Check all wiring. 14. See "To Adjust Carburetor" in Service Adjustments section. 15. Contact a Sears or other qualified service center.
Excessive vibration	<ol style="list-style-type: none"> 1. Worn, bent or loose blade. 2. Bent blade mandrel. 3. Loose/damaged part(s). 	<ol style="list-style-type: none"> 1. Replace blade. Tighten blade bolt. 2. Replace blade mandrel. 3. Tighten loose part(s). Replace damaged parts.
Engine continues to run when operator leaves seat with attachment clutch engaged	<ol style="list-style-type: none"> 1. Faulty operator-safety presence control system. 	<ol style="list-style-type: none"> 1. Check wiring, switches and connections. If not corrected, contact a Sears or other qualified service center.
Poor cut - uneven	<ol style="list-style-type: none"> 1. Worn, bent or loose blade. 2. Mower deck not level. 3. Buildup of grass, leaves, and trash under mower. 4. Bent blade mandrel. 5. Clogged mower deck vent from build-up of grass, leaves, and trash around mandrels. 	<ol style="list-style-type: none"> 1. Replace blade. Tighten blade bolt. 2. Level mower deck. 3. Clean underside of mower housing. 4. Replace blade mandrel. 5. Clean around mandrels to open vent holes.
Mower blades will not rotate	<ol style="list-style-type: none"> 1. Obstruction in clutch mechanism. 2. Worn/damaged mower drive belt. 3. Frozen idler pulley. 4. Frozen blade mandrel. 	<ol style="list-style-type: none"> 1. Remove obstruction. 2. Replace mower drive belt. 3. Replace idler pulley. 4. Replace blade mandrel.

TROUBLESHOOTING CHART

PROBLEM	CAUSE	CORRECTION
Poor grass discharge	<ol style="list-style-type: none"> 1. Engine speed too slow. 2. Travel speed too fast. 3. Wet grass. 4. Mower deck not level. 5. Low/uneven tire air pressure. 6. Worn, bent or loose blade. 7. Buildup of grass, leaves and trash under mower. 8. Mower drive belt worn. 9. Blades improperly installed. 10. Improper blades used. 11. Clogged mower deck vent holes from buildup of grass, leaves, and trash around mandrels. 	<ol style="list-style-type: none"> 1. Place throttle control in "FAST" position. 2. Shift to slower speed. 3. Allow grass to dry before mowing. 4. Level mower deck. 5. Check tires for proper air pressure. 6. Replace/sharpen blade. Tighten blade bolt. 7. Clean underside of mower housing. 8. Replace mower drive belt. 9. Reinstall blades sharp edge down. 10. Replace with blades listed in this manual. 11. Clean around mandrels to open vent holes.
Headlight(s) not working (if so equipped)	<ol style="list-style-type: none"> 1. Switch is "OFF". 2. Bulb(s) or lamp(s) burned out. 3. Faulty light switch. 4. Loose or damaged wiring. 5. Blown fuse. 	<ol style="list-style-type: none"> 1. Turn switch "ON". 2. Replace bulb(s) or lamp(s). 3. Check/replace light switch. 4. Check wiring and connections. 5. Replace fuse.
Battery will not charge	<ol style="list-style-type: none"> 1. Bad battery cell(s). 2. Poor cable connections. 3. Faulty regulator (if so equipped). 4. Faulty alternator. 	<ol style="list-style-type: none"> 1. Replace battery. 2. Check/clean all connections. 3. Replace regulator. 4. Replace alternator.
Loss of drive	<ol style="list-style-type: none"> 1. Freewheel control in "disengaged" position. 2. Motion drive belt worn, damaged, or broken. 3. Air trapped in transmission during shipment or servicing. 	<ol style="list-style-type: none"> 1. Place freewheel control in "engaged" position. 2. Replace motion drive belt. 3. Purge transmission.
Engine "backfires" when turning engine "OFF"	<ol style="list-style-type: none"> 1. Engine throttle control not set at "SLOW" position for 30 seconds before stopping engine. 	<ol style="list-style-type: none"> 1. Move throttle control to "SLOW" position and allow to idle for 30 seconds before stopping engine.

TRACTOR -- MODEL NUMBER 917.275240

SCHEMATIC

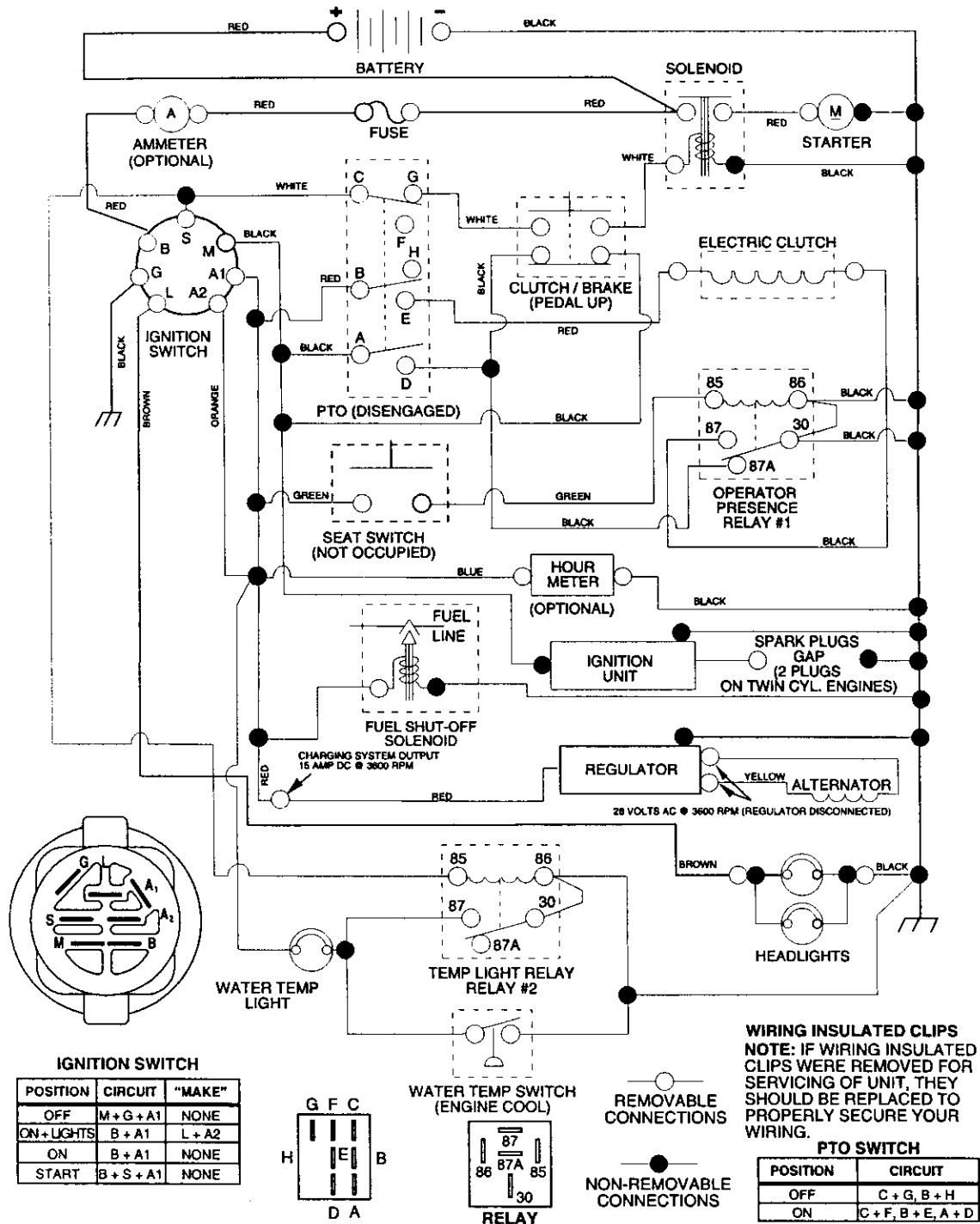

REPAIR PARTS

TRACTOR – MODEL NUMBER 917.275240

DECALS

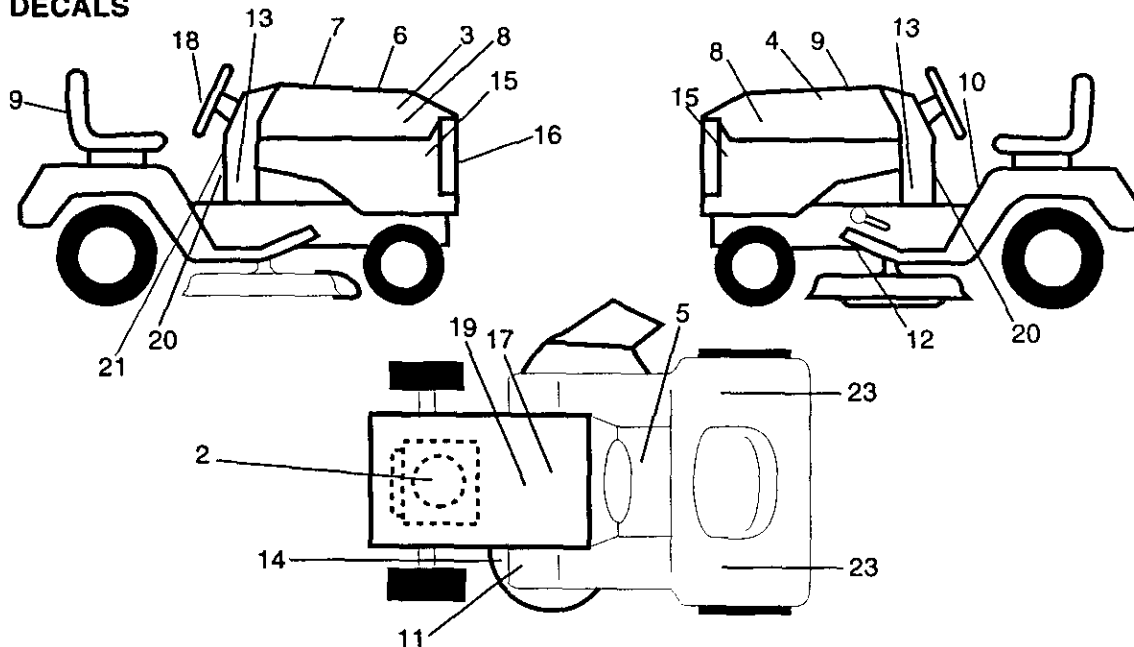

KEY PART NO. NO.

KEY PART NO.	NO.	DESCRIPTION
2	174904	Decal, Hp Engine
3	177907	Decal, Hood RH
4	177908	Decal, Hood LH
5	140837	Decal, Brake Parking Saddle
6	133644	Decal, Maintenance
7	177544	Decal, Replacement
8	177887	Decal, Hood Nameplate Liq/Cool
9	177888	Decal, Hood/Seat
10	156439	Decal, Fender Danger
11	4900J	Decal, Clutch/Brake
12	146790	Decal, V-Belt Dr Sch
13	174862	Decal, Dash
14	175291	Decal, Deck Schematic
15	177376	Decal, Side Panel

KEY PART NO. NO.

KEY PART NO.	NO.	DESCRIPTION
16	177400	Decal Grille
17	149516	Decal, Btry Dngr/Psn Eng. Acme
18	177890	Decal, Insert Strg
19	138047	Decal, Battery
20	177375	Decal, Lower Dash
21	177704	Decal, Dash Liq Cool
23	106202X	Reflector, Taillight
--	138311	Decal, Handle LFT Height Adjust (Lift Handle)
--	142342	Decal, Bypass Control (Drawbar)
--	157199X428	Pad, Footrest
--	177812	Owner's Manual, English
--	177813	Owner's Manual, Spanish

WHEELS AND TIRES

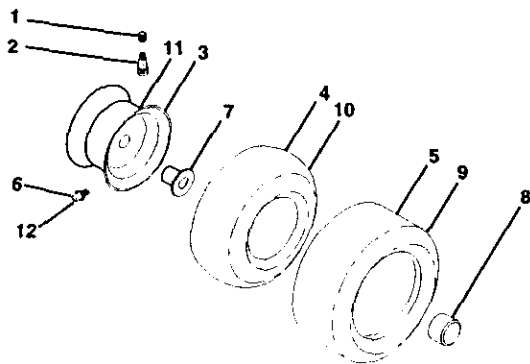

KEY PART NO. NO.

KEY PART NO.	NO.	DESCRIPTION
1	59192	Cap Valve Tire
2	65139	Stem Valve
3	148736X417	Rim Asm Front
4	8134H	Tube, Front (Service Item Only)
5	148741	Tire, Front
6	278H	Fitting Grease (Front Wheel Only)
7	9040H	Bearing Flange (Front Wheel Only)
8	104757X428	Cap Axle (Front Wheel Only)
9	151607	Tire Rear
10	7154J	Tube Rear (Service Item Only)
11	148738X417	Rim Asm Rear
12	6856M	Fitting Grease
--	144334	Sealant, Tire (10 oz. Tube)

NOTE: All component dimensions given in U. S. inches 1 inch = 25.4 mm

TRACTOR – MODEL NUMBER 917.275240

ELECTRICAL

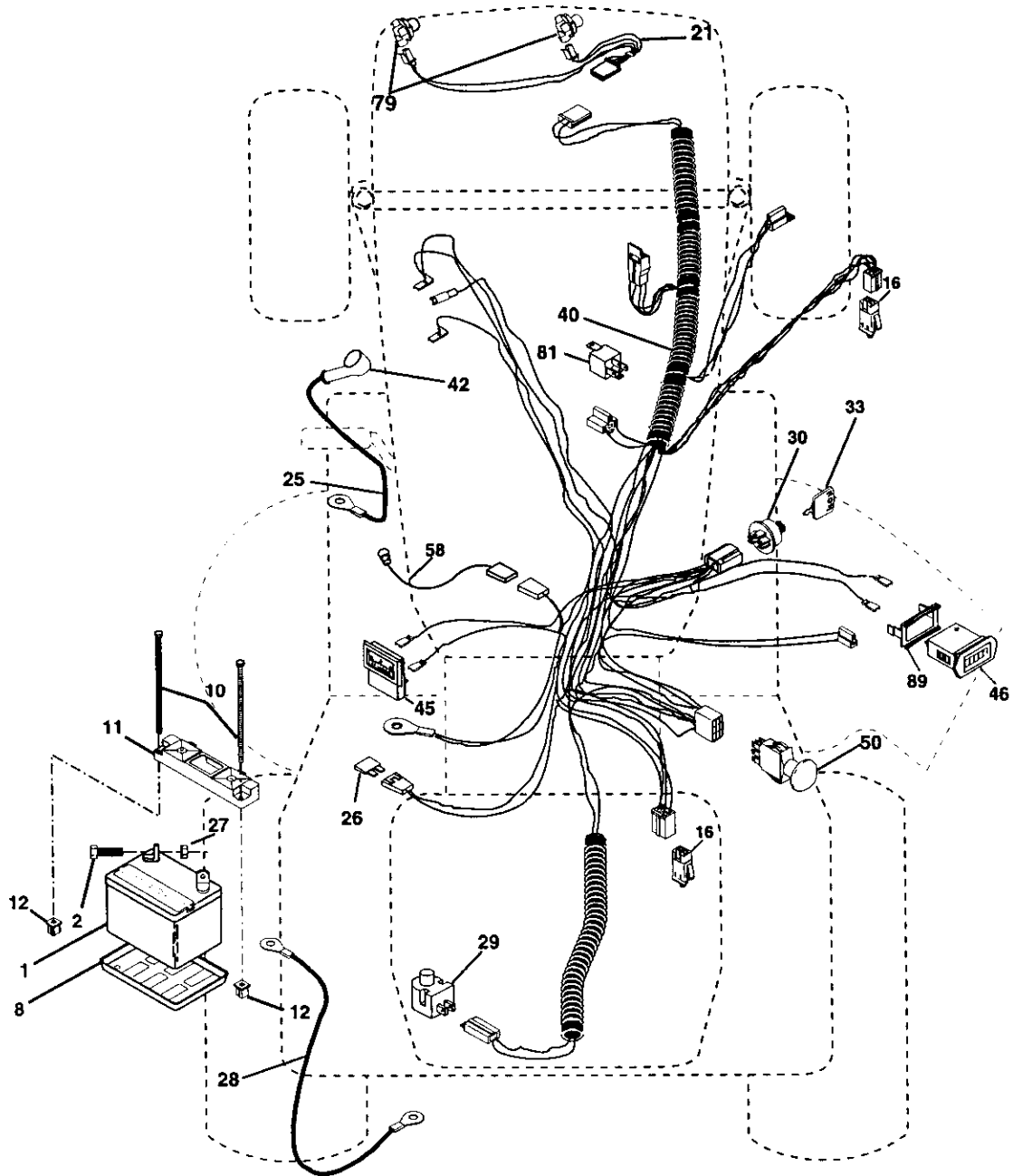

TRACTOR -- MODEL NUMBER 917.275240

ELECTRICAL

KEY NO.	PART NO.	DESCRIPTION
1	144927	Battery
2	74760412	Bolt Hex Head 1/4-20 x 3/4
8	7603J	Tray, Battery
10	145211	Bolt 1/4-20 x 7.5 Zinc
11	150109	Hold down Battery Dash Mount
12	145769	Nut Push Nylon 1/4"
16	153664	Switch Interlock Push-In
21	166184	Harness Socket Light w/4152J
25	150755	Cable 4 Ga. 31" Red CV25 w/16.W.
26	108824X	Fuse
27	73510400	Nut, Keps Hex 1/4-20 UNC
28	170697	Cable, Ground
29	160784	Switch, Plunger
30	175442	Switch, Ign
33	175447	Key, Ignition
40	174909	Harness Ign.
42	154336	Cover Terminal
45	122822X	Ammeter
46	169635	Meter, Hour
50	174652	Switch, PTO
58	175024	Harness LPKG Stealth Water Temp
79	163997	Bulbholder
81	109748X	Relay Asm.
89	169639	Bracket Snap-In

NOTE: All component dimensions given in U. S.
inches 1 inch = 25.4 mm

TRACTOR – MODEL NUMBER 917.275240

CHASSIS AND ENCLOSURES

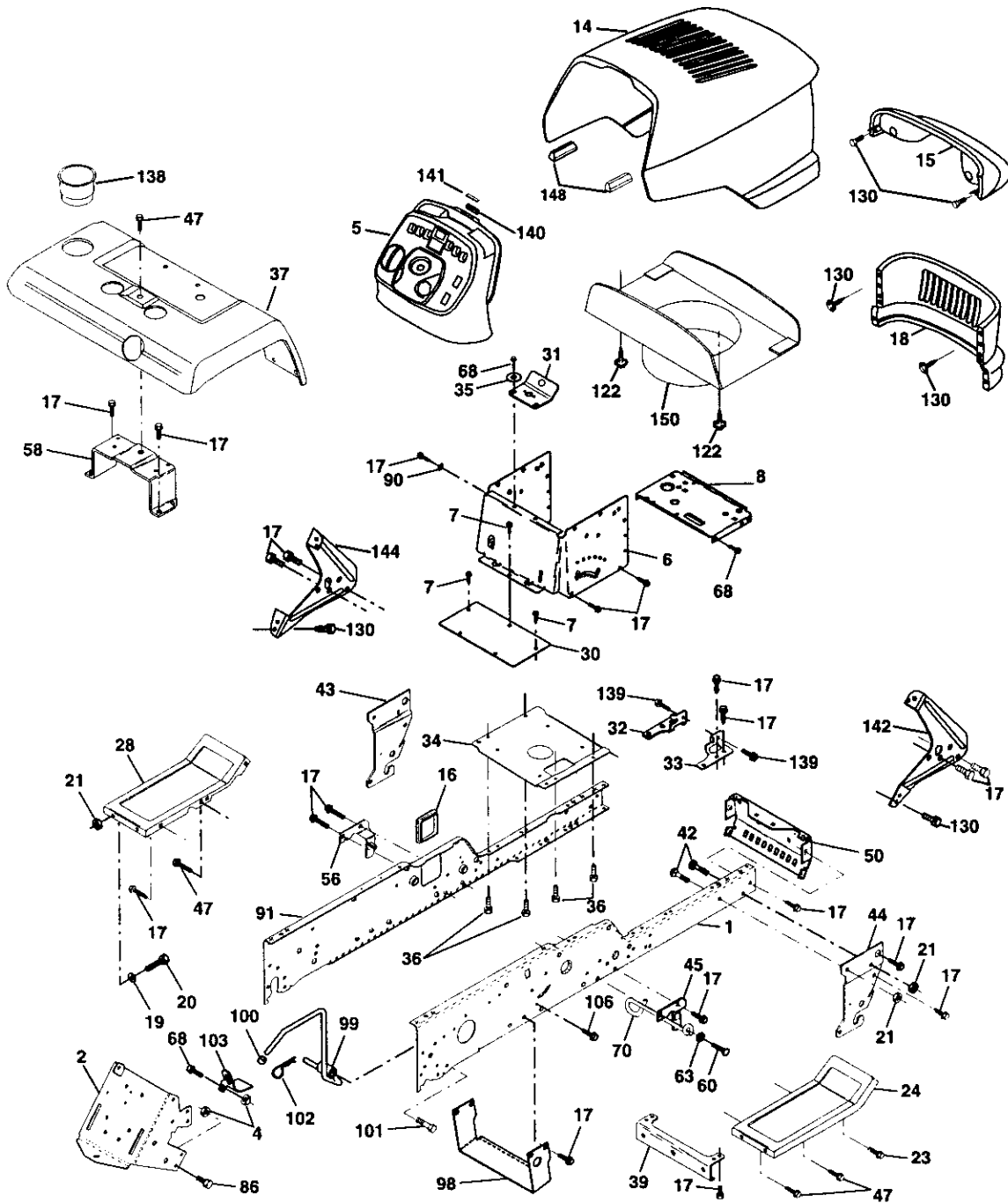

TRACTOR – MODEL NUMBER 917.275240
CHASSIS AND ENCLOSURES

KEY PART NO.	NO.	DESCRIPTION
1	175465	Rail, Frame RH VGT
2	175282	Drawbar, Gt
4	73800700	Nut, Lock Hex 7/16 Unc
5	163976X418	Dash
6	157882	Dash Asm., Lower VGT
7	17720408	Screw, Thd Cut 1/4-20 x 1/2
8	145166	Support, Dash 1-Pc. Battery
14	175260X615	Hood Asm Pnt
15	177612	Lens, Asm Headlight
16	121794X	Cover, Access
17	17060612	Screw 3/8-16 x .75
18	174515X615	Grille
19	19131312	Washer 13/32 x 13/16 x 12 Ga.
20	STD523710	Bolt, Fin Hex 3/8-16 x 1
21	STD541437	Nut, Crownlock 3/8-16 Unc
23	17060616	Screw 3/8-16 x 1.0
24	145243X615	Footrest, RH
28	145244X615	Footrest, LH
30	145052	Saddle, Hydro 1995
31	161419	Bracket Support 1-pc VGT Steering
32	161327	Bracket Pivot Chassis Lh
33	161326	Bracket Pivot Chassis Rh
34	177018	Plate Asm. Engine Chassis
35	19111116	Washer 11/32 x 11/16 x 16 Ga.
36	17060512	Screw 5/16-18 x 3/4
37	167287X615	Fender Pnt
39	175278	Bracket, Axle Front
42	STD533710	Bolt, Carriage 3/8-16 x 1
43	136939	Bracket, Spnsn Front Lh
44	136940	Bracket, Spnsn Front Rh
45	176018	Bracket Asm., Susp Chassis Rh

KEY PART NO.	NO.	DESCRIPTION
47	17670608	Screw 3/8-16 x 1/2
50	175476	Bracket, Chassis Front
56	176016	Bracket Asm., Susp Chassis Lh
58	175315	Bracket Fender
60	17060620	Screw 3/8-16 x 1-1/4
63	19131614	Washer 13/32 x 1 x 14 Ga.
68	17490508	Screw, Thd 5/16-18 x 1/2
70	177679	Belt Keeper VGT Ground Drive
86	74760716	Bolt, Fin Hex 7/16-14 Unc x 1
90	STD551237	Washer, Lock Ext. I Tooth 3/8
91	175464	Rail, Frame Lh VGT
98	140503	Bracket Skid Chassis
99	140871	Rod By Pass
100	71673	Cap By Pass Rod
101	17490628	Screw Thdrol 3/8-16 x 1-3/4
102	STD624003	Retainer, Spring
103	142273	Lock, By Pass
106	138776	Bolt 5/16-18 Type TT
122	161464	Screw Hex Wshd 8-18 x 7/8
130	164863	Screw Hwhd Hi-Lo #13-16
138	163975X418	Cupholder
139	171873	Bolt Shoulder 5/16-18 TT
140	163806	Magnet YT/GT
141	163805	Striker Plate YT/GT
142	161897	Bracket Dash Rh
144	161900	Bracket Dash Lh
148	164655	Extrusion Bumper
150	176885	Duct Heat Hood
152	177956	Shield Browning

NOTE: All component dimensions given in U. S. inches 1 inch = 25.4 mm

TRACTOR – MODEL NUMBER 917.275240

GROUND DRIVE

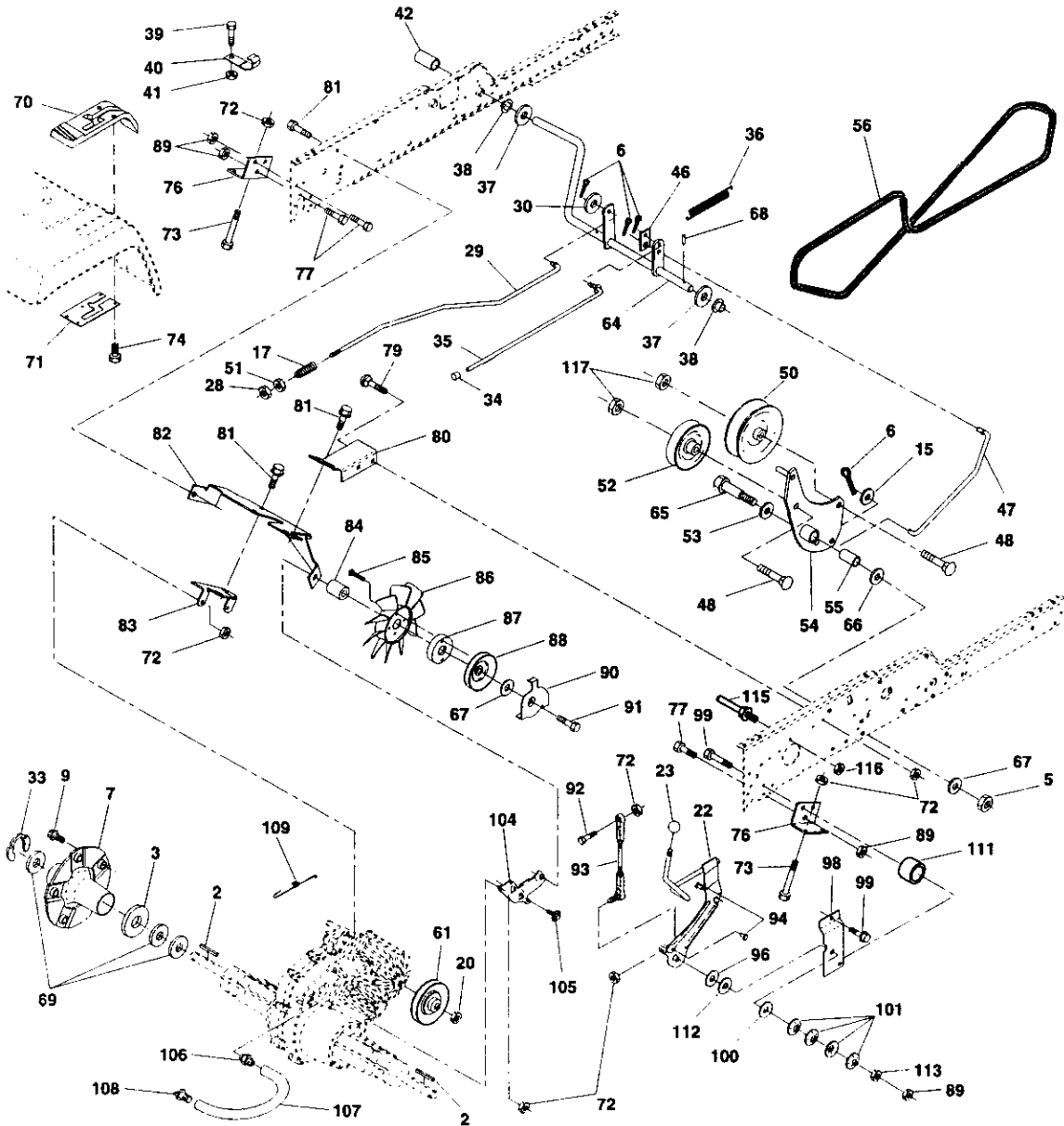

TRACTOR -- MODEL NUMBER 917.275240

GROUND DRIVE

KEY NO.	PART NO.	DESCRIPTION	KEY NO.	PART NO.	DESCRIPTION
2	7070E	Key 1/4 x 2.5	72	STD541431	Nut, Crownlock 5/16-18
3	7563R	Washer, Thrust, Axle	73	74490548	Bolt Hex Flghd 5/16-18 x 3 Gr5
5	STD541437	Nut, Crownlock 3/8-16	74	142432	Screw Hex Wsh. Hi-Lo 1/4-1/2
6	STD561210	Pin, Cotter	76	140481	Bracket Transaxle
7	140507	Wheel, Hub Assembly	77	74760716	Bolt Fin Hex 7/16-14 x 1
9	140080	Bolt, Hub	79	72110505	Bolt Carriage 5/16-18 x 5/8
15	STD551037	Washer	80	140484	Bracket Torque RH
17	140921	Spring	81	17060612	Screw 3/8-16 x 3/4
20	73940800	Nut Hex Jam Toplock 1/2-20	82	150586	Bracket Mount Torrqe/Fan
22	156103	Arm Asm Shift	83	140479	Strap Torque Mid
23	130564	Knob	84	140490	Spacer
28	STD541237	Nut	85	17541020	Screw #10-24 x 1-1/4
29	140494	Brake, Rod	86	140462	Fan 7" Hydro
30	19131616	Washer 13/32 x 1 x 16 Ga.	87	140491	Adapter Fan
33	12000053	Ring E	88	161592	Pulley Idler
34	71673	Cap, Plunger	89	73680700	Nut Crownlock 7/16-14 Unc
35	137648	Rod, Parking Brake	90	140489	Keeper Belt
36	149412	Spring, Drive Ground	91	17490644	Screw Thdrol 3/8-16 x 2-3/4
37	121749X	Washer 25/32 x 1-1/4 x 16 Ga.	92	74760520	Bolt Fin Hex 5/16-18 x 1.25
38	150035	Nyliner	93	140502	Link Shift Asm
39	74321016	Screw, Fin. #10-24 x 1	94	133835	Fastener Christmas Tree
40	5304J	Actuator, Interlock Switch	96	141103	Washer Nickel Plated
41	73931000	Nut Centerlock 10-24 Unc	98	141004	Bracket Shift
42	8883R	Cover, Pedal	99	17060624	Screw 3/8-16 x 1-1/2
46	145170	Retainer, Spring	100	126881X	Washer Compression
47	138228	Clutch Rod	101	156106	Washer Belleville
48	72110612	Bolt, Carr. 3/8-16 x 1-1/2 Gr. 5	104	140480	Bracket Idler
50	131494	Pulley, Idler, Flat	105	17580408	Screw Tap 1/4-20 x 1/2
51	STD541437	Nut, Crownlock 3/8-16 UNC	106	142918	O-Ring Asm Hydro Gear 70110
52	139123	Pulley, Idler, Grooved	107	154739	Line Fuel Hydro 15" VGT
53	207J	Washer, Hardened	108	142917	Cap Asm Vent Hydro Gear 70109
54	161590	Clutch, Arm Assembly	109	140929	Spring Return Brake
55	105706X	Bearing, Idler	111	156240	Spacer Shift Lever VGTH
56	140218	V-Belt	112	156104	Washer Nylon High Temp
61	140488	Pulley, Transaxle	113	73220700	Nut-Hex ASF 7/16-14 UNC
64	154752	Shaft, Clutch/Brake Pedal	115	123405X	Keeper Belt T/A Gnd Dr
65	67609	Bolt, Shoulder	116	73900500	Nut Lock Hex Flange 5/16-18
66	140296	Washer, Hardened	117	73900600	Nut, Lock Flg. 3/8-16
67	19131312	Washer, Flat	--	163198	Transaxle (See Breakdown)
68	5142H	Pin, Roll			Hydro Gear 222-3010
69	123800X	Washer			
70	164892X418	Console Hydro Fender			
71	151179	Plate Console Shift			

NOTE: All component dimensions given in U. S. inches 1 inch = 25.4 mm

TRACTOR -- MODEL NUMBER 917.275240

STEERING

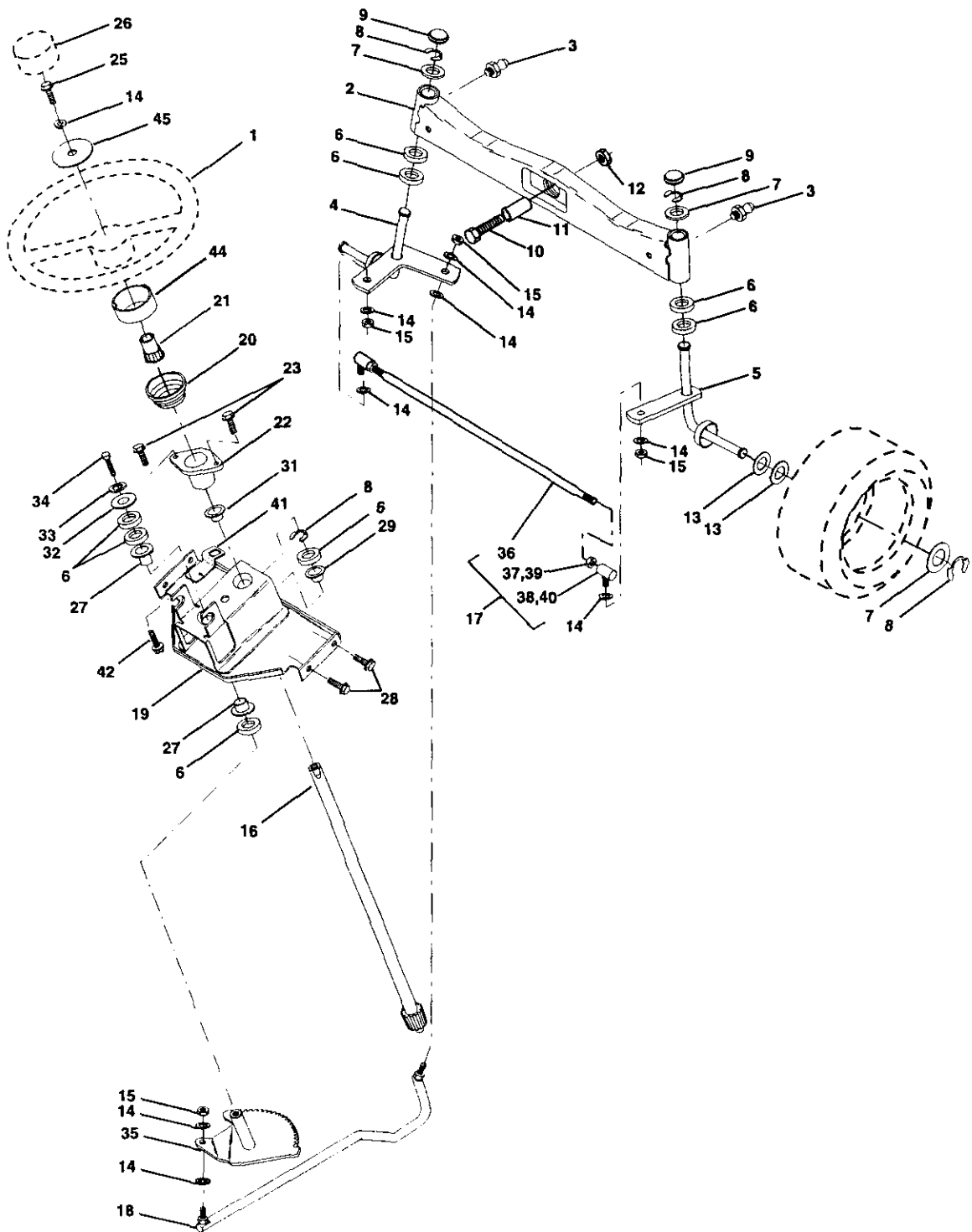

TRACTOR – MODEL NUMBER 917.275240

STEERING

KEY PART NO.	PART NO.	DESCRIPTION
1	175139X418	Wheel, Steering
2	137094	Axle Asm., Front
3	6855M	Fitting, Grease
4	161849	Spindle Asm, LH
5	161848	Spindle Asm., RH
6	6266H	Bearing, Race Thrust Harden
7	121748X	Washer 25/32 x 1-5/8 x 16 Ga.
8	12000029	Ring, Klip #T5304-75
9	121232X	Cap, Spindle
10	74781044	Bolt, Fin Hex 5/8-11 x 2-3/4
11	136518	Spacer Bearing Axle Front
12	73901000	Nut, Lock Flange 5/8-11 Unc
13	121749X	Washer 25/32 x 1-1/4 x 16 Ga.
14	STD551137	Washer, Lock Hvy Hlcl Spr 3/8
15	STD541537	Nut, Lock Center 3/8-24 UNF
16	145103	Shaft Asm., Steering
17	137347	Rod Tie Service
18	175572	Draglink
19	156011	Support Asm., Steering Vgt
20	177646X418	Boot, Steering
21	159945	Adapter, Wheel Steering
22	155105	Bushing, Strg. Blk
23	152927	Screw
25	STD523710	Bolt, Fin Hex 3/8-16 x 1 Gr. 5
26	175140X418	Cap, Wheel Steering
27	3366R	Bearing, Col. Strg.
28	17000612	Screw 3/8-16 x 3/4
29	104239X	Bearing, Flange
31	138136	Bushing, Nylon Snap
32	19111610	Washer 11/32 x 1 x 10 Ga.
33	STD551131	Washer, Lock Hvy Hlcl Spr 5/16
34	STD523107	Bolt, Hex Hd 5/16-18 x 3/4
35	138059	Gear, Sector Steering
36	137156	Tie Rod
37	73360600	Jam Nut RH Thread
38	109850X	Joint Asm. Ball RH Thread
39	73700600	Nut Hex Jam 3/8-24 Unf LH
40	109851X	Joint Asm Ball LH
41	155246	Bracket Switch Interlock VGT 97
42	17490508	Screw Thdrol 5/16-18 x 1/2 Tyl
44	160135X614	Extension, Steering
45	19132411	Washer 13/32 x 1-1/20 x 11 Ga.

NOTE: All component dimensions given in U. S. inches 1 inch = 25.4 mm

TRACTOR – MODEL NUMBER 917.275240

ENGINE

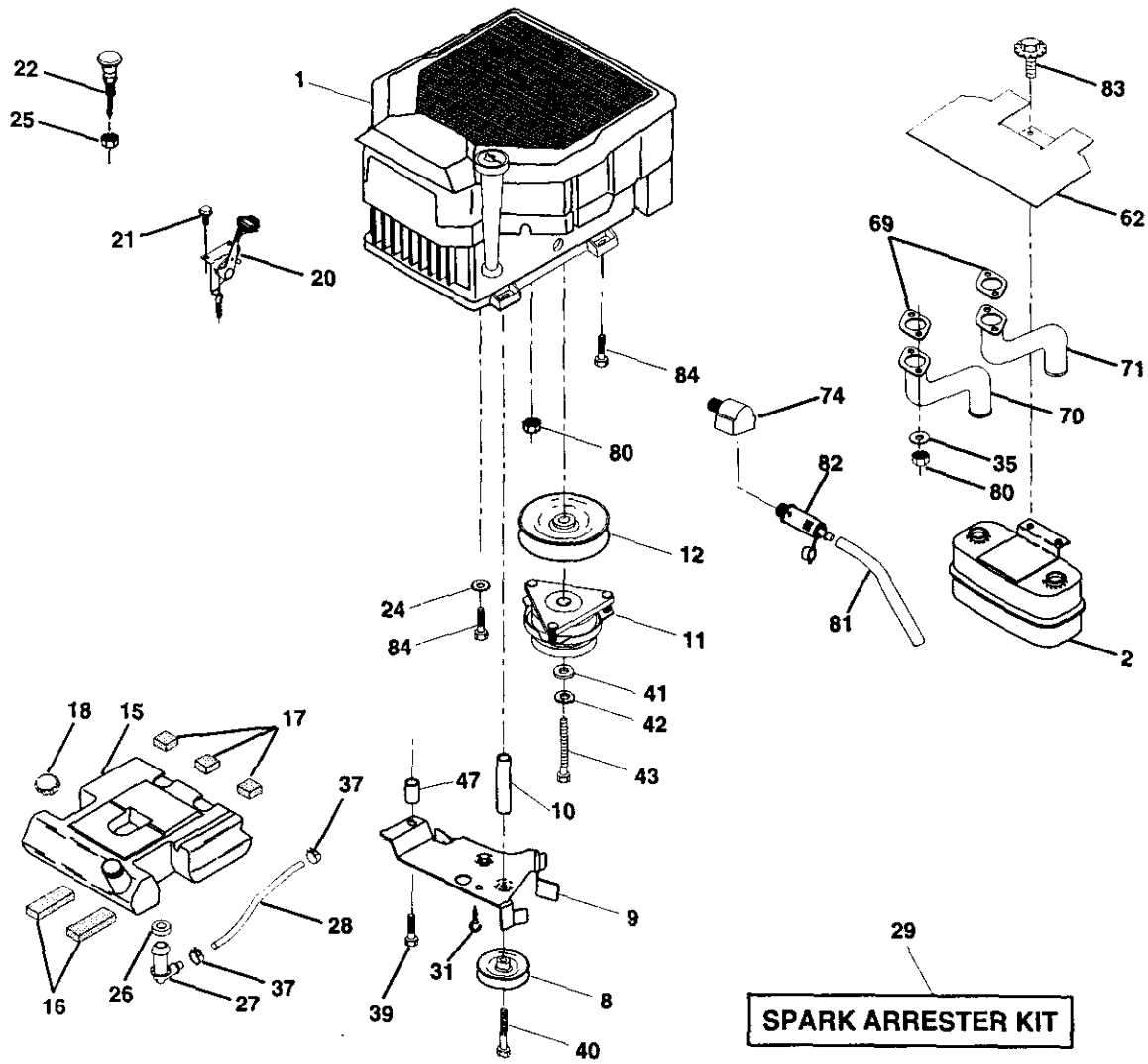

TRACTOR – MODEL NUMBER 917.275240

ENGINE

KEY PART NO.	PART NO.	DESCRIPTION
1	-----	Engine (See Breakdown) Kohler LV675-851509
2	149723	Muffler
7	151396	Muffler Asm Guard
8	121361X	Pulley V-Idler
9	177748	Belt Engine Keeper Asm
10	175287	Bushing
11	174605	Clutch Electric
12	143996	Pulley Engine VGT Elect Clutch
15	151346	Tank Fuel Rear 3.50 YT/GT 96
16	109227X	Pad Spacer
17	106082X	Pad Spacer
18	161493	Cap Fuel 5-1/2" Vented Cov.
20	177328X505	Control Throttle
21	164863	Screw HWHD Hi-Lo #13-16 x 3/4
22	175441X505	Control Choke
24	STD551237	Lockwasher Ext Tooth 3/8
25	73920600	Nut Keps 3/8 - 24 UNF
26	3645J	Bushing
27	139277	Stem Tank Fuel
28	7834R	Fuel Line
29	137180	Spark Arrester Kit
35	10010500	Washer Split
37	123487X	Clamp Hose
39	17490636	Screw TT 3/8-16 x 2-1/4 Unc
40	17490664	Screw TT 3/8-16 x 4
41	126197X	Washer 1-1/2 OD X 15/32 ID X .250
42	STD551143	Washer Lock 7/16
43	173937	Bolt Hex 7/16 - 20 X 4 Gr. 5 - 1.5 Thr.
47	175288	Bushing
62	146629	Shield Heat Muffler
69	24-041-02	Gasket Kohler CV18-CV26
70	175545	Tube Exhaust LH
71	175546	Tube Exhaust RH
74	162295	Elbow Street Brass
80	M73030800	Nut Flange M8-1.25 Non Lk Zinc
81	148456	Drain Tube
82	148315	Drain Plug
83	171877	Bolt 5/16-18 Unc x 3/4 w/Sems
84	17060624	Screw 3/8-16 x 1/2

NOTE: All component dimensions given in U. S.
inches 1 inch = 25.4 mm

TRACTOR – MODEL NUMBER 917.275240

SEAT ASSEMBLY

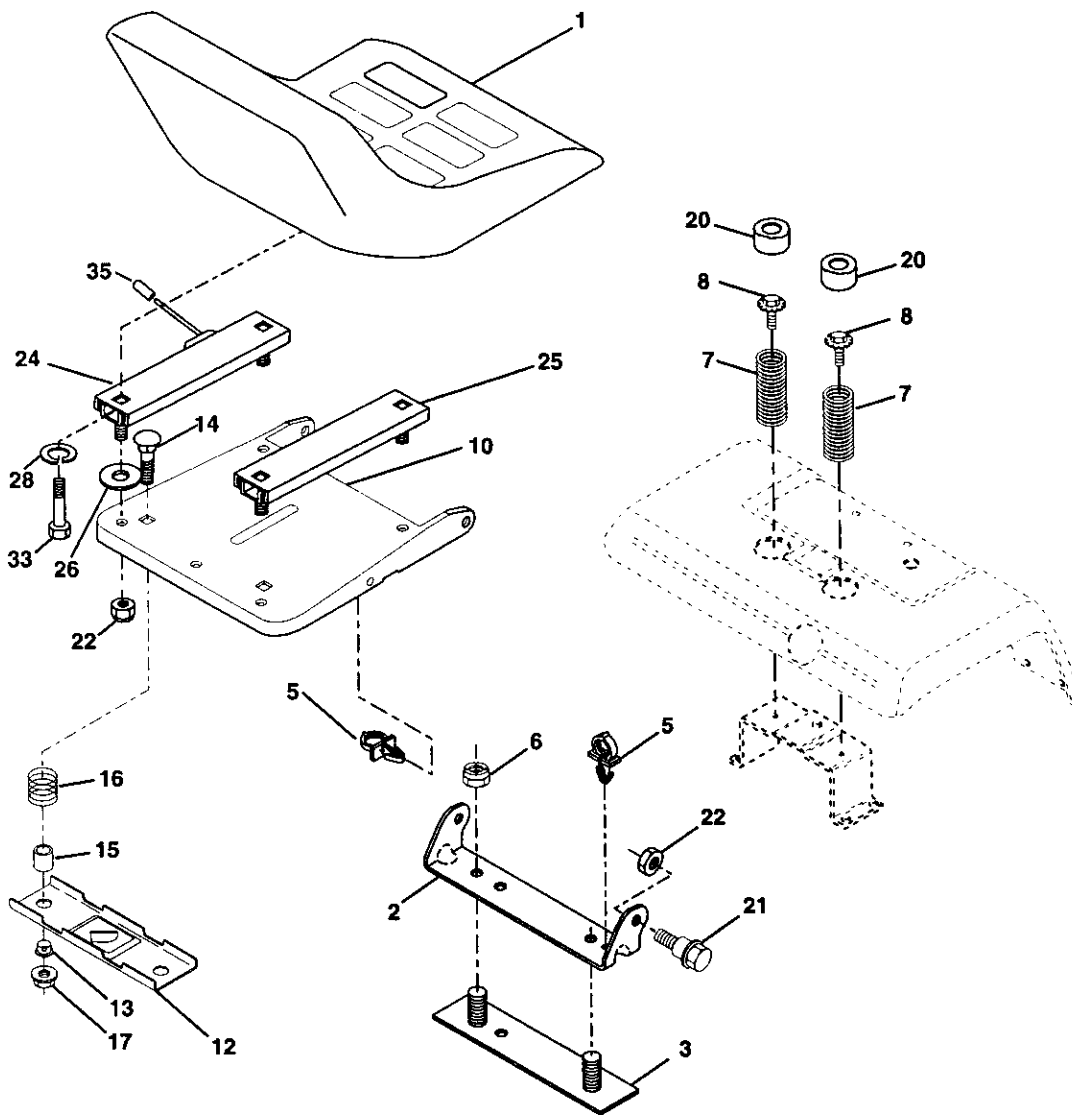

KEY PART NO. NO.

KEY PART NO.	NO.	DESCRIPTION
1	177978	Seat
2	140551	Bracket, Pivot Seat
3	140675	Strap, Fender
5	145006	Clip, Push In, Hinged
6	STD541437	Nut, Crownlock 3/8-16 Unc
7	124181X	Spring, Seat Cprsn
8	171877	Bolt 5/16-18 Unc x 3/4 w Sems
10	174894	Pan, Seat
12	121246X	Bracket, Mounting Switch
13	121248X	Bushing, Snap
14	72050412	Bolt, Carriage 1/4-20 X 1-1/2
15	121249X	Spacer, Split
16	123740X	Spring, Cprsn

KEY PART NO. NO.

KEY PART NO.	NO.	DESCRIPTION
17	123976X	Nut, Lock 1/4 Lge Flg Gr. 5
20	124238X	Cap, Spring Seat
21	171852	Bolt, Shoulder 5/16-18
22	STD541431	Nut, Crownlock 5/16-18 Unc
24	177946	Track Slide Seat LH Locking
25	177947	Track Slide Seat RH Free
26	19111012	Washer 11/32 x 5/8 x 12 Ga.
28	10010500	Washer Split
33	74780512	Bolt Fin Hex 5/16-18 Unc x 3/4
35	178426	Cap Plunger Red

NOTE: All component dimensions given in U. S. inches 1 inch = 25.4 mm

TRACTOR -- MODEL NUMBER 917.275240

LIFT ASSEMBLY

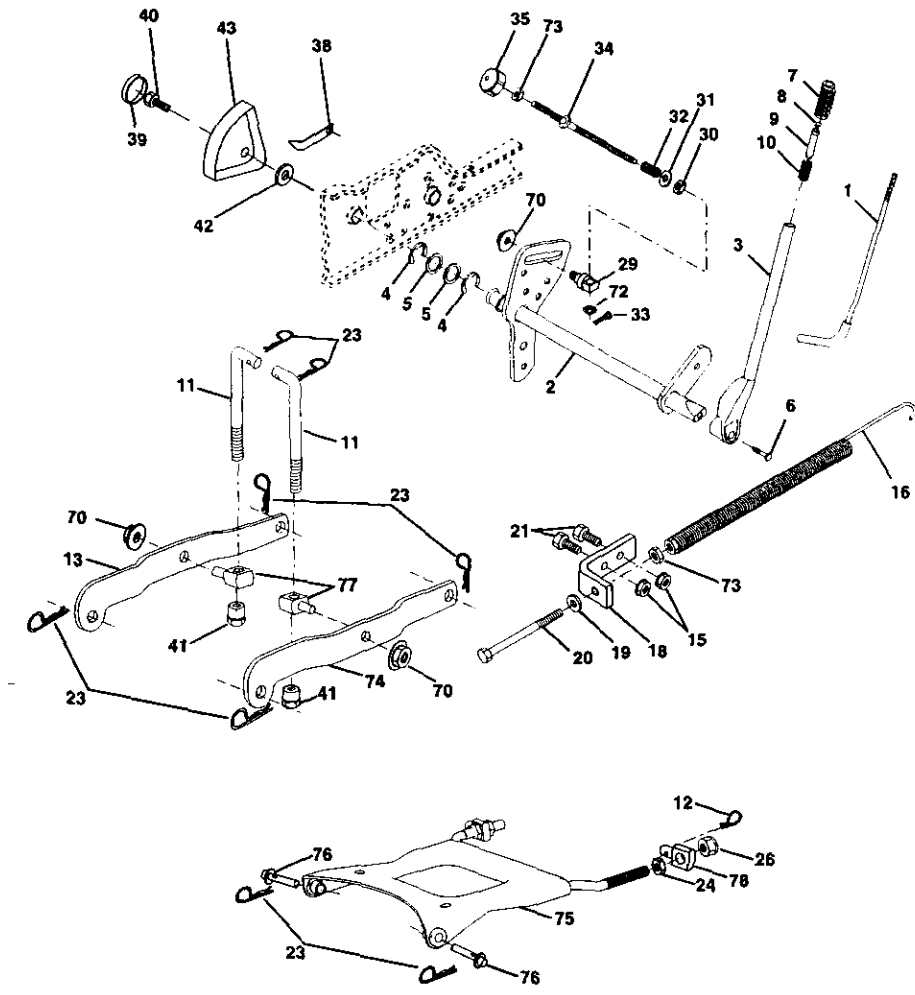

**KEY PART
NO. NO.**

DESCRIPTION

**KEY PART
NO. NO.**

DESCRIPTION

1	121006X	Rod Asm., Lever
2	177535	Shaft Asm., Lift Vgt
3	159189	Lever Asm., Lift Rh
4	12000022	E-Ring Truarc #5133-87
5	19292016	Washer 29/32 x 1-1/4 x 16 Ga.
6	71110624	Bolt, Fin Hex 3/8-16 x 1-1/2
7	175830	Grip, Handle Fluted
8	175831	Button, Plunger
9	122364X	Plunger, Button
10	2876H	Spring 2-1/8"
11	175375	Link Lift
12	163552	Retainer, Spring
13	175378	Arm, Suspension Rear LH
15	STD541437	Nut, Crownlock 3/8-16 Unc
16	674A247	Spring Asm., Assist Lift
18	143363	Bracket, Spring Assist
19	STD551037	Washer 13/32 x 13/16 x 16 Ga.
20	5328J	Bolt, Adjust Spring Assist
21	STD523710	Bolt, Fin Hex 3/8-16 x 1
23	STD624008	Retainer, Spring
24	73350800	Nut, Jam Hex 1/2-13 Unc
26	73680800	Nut, Crownlock 1/2-13 Unc
29	150233	Trunnion, Inf Height
30	110807X	Nut, Special

31	19131016	Washer 13/32 x 5/8 x 16 Ga.
32	137150	Spring, Compression Inf Hgt
33	STD560907	Pin, Cotter 3/32 x 1/2
34	137167	Rod, Adj Lift
35	138057	Knob, Inf 3/8-16 Unc
38	155097	Pointer, Height Indicator
39	123935X	Plug, Hole
40	17060516	Screw 5/16-18 x 1 SMGML Tap/R
41	175994	Nut Lift Link 7/16-20
42	19112410	Washer 11/32 x 1-1/2 x 10 Ga.
43	123934X	Scale, Indicator Height
70	145212	Nut Hex Flange Lock
72	110452X	Nut Push Phos & Oil
73	73350600	Nut Hex Jam 3/8-16 Unc
74	175802	Arm Suspension Rear Rh
75	175805	Plate Asm Susp. Front VGT
76	175560	Pin Flange
77	176205	Trunnion Suspt. Arm
78	175689	Trunnion Front Susp.

NOTE: All component dimensions given in U. S. inches 1 inch = 25.4 mm

TRACTOR – MODEL NUMBER 917.275240

MOWER DECK

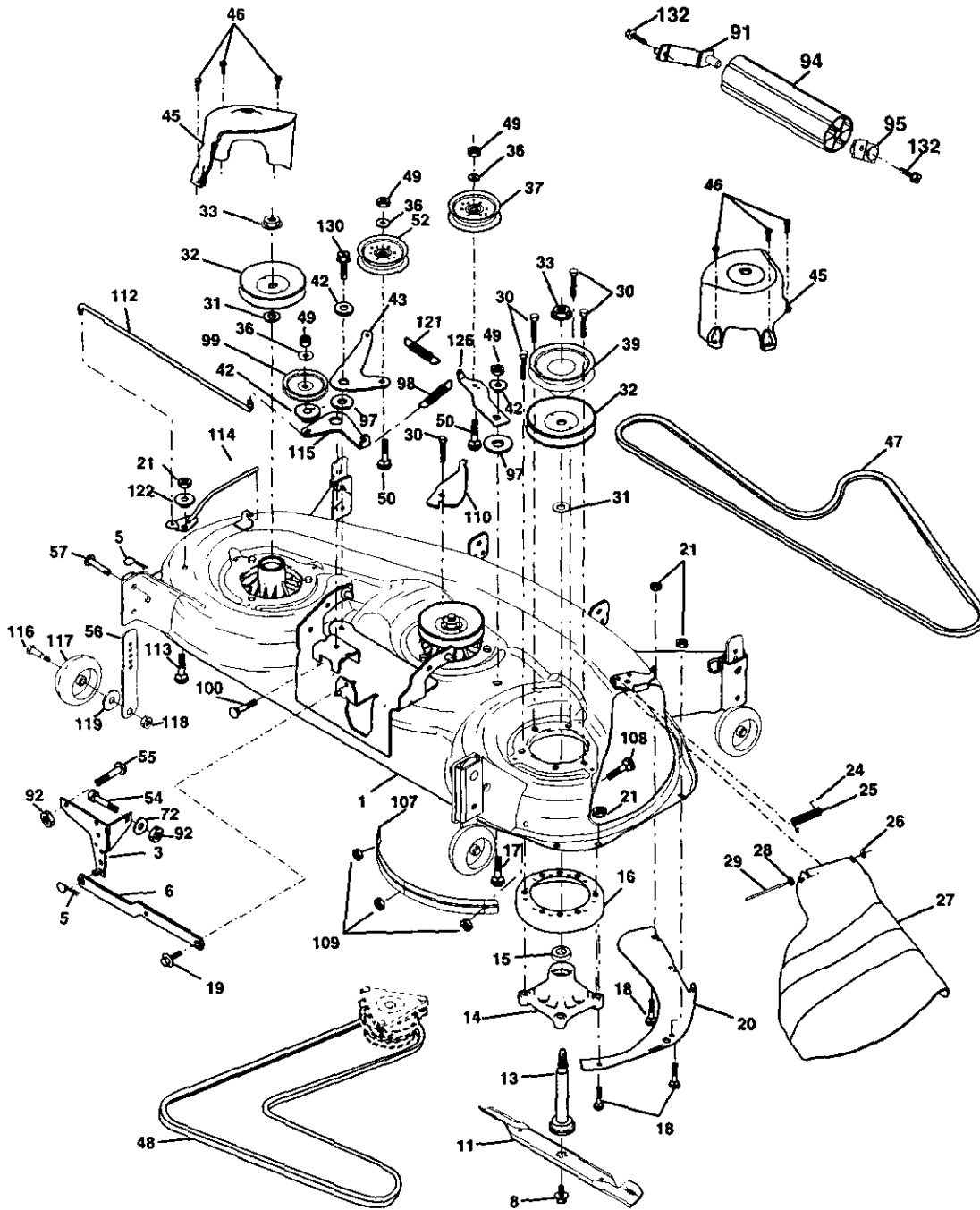

TRACTOR – MODEL NUMBER 917.275240

MOWER DECK

KEY PART NO.	PART NO.	DESCRIPTION	KEY PART NO.	PART NO.	DESCRIPTION
1	174348	Deck Weldment Mower 48	50	72110612	Bolt, Carr. 3/8-16 x 1-1/2 Gr. 5
3	178915	Bracket Asm, Sway Bar	52	175820	Pulley Idler Flat
5	4939M	Retainer Spring	56	155986X505	Bar Pnt Adj.
6	130832	Arm, Suspension, Rear (Sway Bar)	57	156941	Pin Head Rivet
8	174365	Bolt 7/16 Asm. Blade	91	175996	Bracket Asm. Noseroller LH
11	173920	Blade	94	176066	Noseroller
13	137553	Shaft Asm. w/Lower Bearing	95	175384	Bracket Asm Noseroller RH
14	174356	Mandrel Asm.	97	133943	Washer Hardened
15	110485X	Bearing, Ball, Mandrel	98	174370	Spring Primary Drive
16	174493	Stripper Mandrel Deck	99	175080	Pulley Idler "V"
17	72110610	Bolt RDHD Sq Neck 3/8-16x1.25	100	72110616	Bolt RDHD Sqnk 3/8-16 UNC x 2
18	72140505	Bolt, Carriage 5/16-18 x 5/8	107	175294	Baffle Vac Edge Mower
19	132827	Bolt, Hex Hd, Shoulder 5/16-18	108	72110404	Bolt Carr.
20	174378	Baffle, Vortex Mower	109	73680400	Nut Crownlock 1/4-20
21	73680500	Nut, Crownlock 5/16-18 UNC	110	175016	Arm Spring Secondary
24	105304X	Cap, Sleeve	112	174387	Link Tension Relief Lever
25	178102	Spring, Torsion	113	72110508	Bolt Carr. 5/16-18 x 1
26	110452X	Nut, Push	114	174384	Tension Asm. Relief Lever
27	174346X428	Deflector Shield	115	174609	Arm Spring Tension Relief
28	19111016	Washer 11/32 x 5/8 x 16 Ga.	116	137644	Bolt, Shoulder
29	131491	Rod, Hinge	117	174873	Gauge Wheel
30	157722	Screw, Thdroll Washer Head	118	73930600	Nut, Centerlock 3/8-16 UNC
31	129963	Washer, Spacer Mower Vented	119	19121414	Washer 3/8 x 7/8 x 14 Ga.
32	177865	Pulley, Mandrel	121	174371	Spring Secondary Drive
33	178342	Nut, Fig. Top Lock Cntr. 9/16	122	174606	Bushing Pivot Tension Relief
36	19131316	Washer 13/32 x 13/16 x 16 Ga.	126	174372	Arm, Idler, Primary Deck
37	173437	Pulley, Idler, Flat	130	17060616	Screw 3/8-16 x 1.0
39	174375	Pulley, Idler, Driven	131	19131316	Washer 13/32 x 13/16 x 16 Ga.
42	165723	Spacer, Retainer	132	17490612	Screw Thdrol 3/8-16 x 3/4
43	174373	Arm, Idler Secondary	--	175312	Replacement Mower, Complete
45	174343	Cover, Mandrel Deck	--	174356	Mandrel Asm. Service (Includes Key Nos. 13-15 and 33)
46	137729	Screw, Thdroll. 1/4-20 x 5/8			
47	174369	V-Belt, Mower, Secondary			
48	174368	V-Belt, Mower, Primary			
49	73680600	Nut, Crownlock 3/8-16 UNC			

NOTE: All component dimensions given in U. S. inches 1 inch = 25.4 mm

TRACTOR--MODEL NUMBER 917.275240
TRANSAXLE--MODEL NUMBER 222-3010

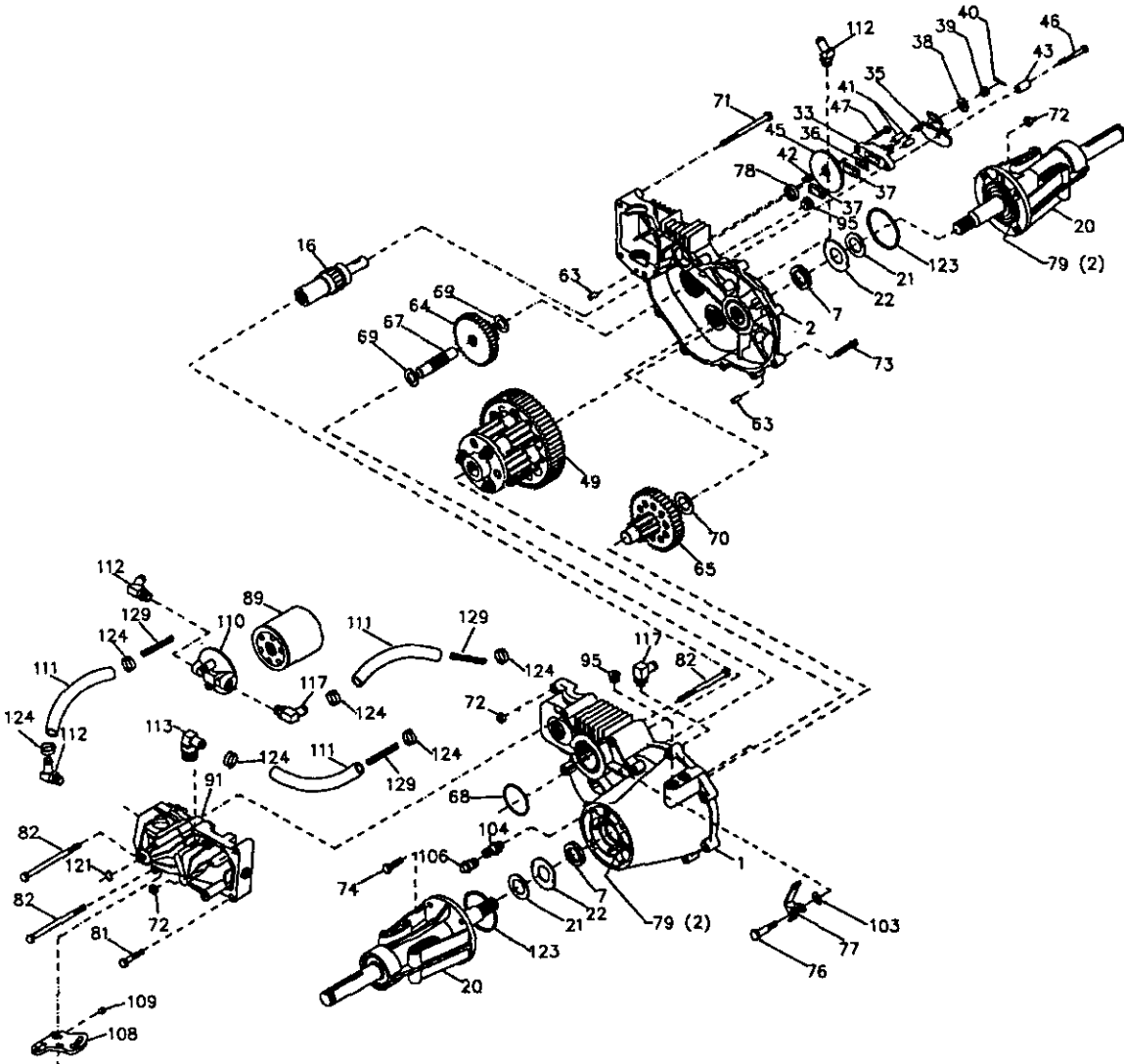

TRACTOR--MODEL NUMBER 917.275240

TRANSAXLE--MODEL NUMBER 222-3010

KEY PART NO.	PART NO.	DESCRIPTION	KEY PART NO.	PART NO.	DESCRIPTION
1	164591	Assembly, Housing, LH	72	153767	Locknut, Hex 5/16-18
2	164592	Assembly, Housing, RH	73	142904	Bolt, Hex 5/16-18 x 1-1/2
7	153765	Oil Seal .984 x 1.5 x .25	74	142905	Hex Cap Screw 5/16-18 x 1
16	142876	Brake Shaft Assembly	76	142907	Shoulder Bolt
20	142877	Axle Mounting Horn Assembly	77	142908	Freewheel Actuating Arm
21	142878	Washer 1.0 x 1.63 x .08	78	142909	Oil Seal .625 x 1.0 x .25
22	142879	Washer 1.0 x 2.06 x .09	79	153768	Grease (10 oz. Tube)
33	142929	Brake Yoke Assembly	81	142910	Bolt, Hex 5/16-18 x 1-3/4
35	142880	Brake Arm	82	142911	Bolt 5/16-18 x 4-1/2
36	142882	Puck Plate	89	142912	Filter, Spin On
37	142883	Brake Puck	91	153769	Pump, BDU-10L-122
38	142884	Washer 7/8 O.D. x 7/16 x .060	95	142914	Plug, Straight Thread
39	142885	Nut, Castle 5/16-24	96	153770	60° 7/18 SAE x 5/16 Fitting
40	142886	Cotter Pin	103	142916	Washer
41	142887	Brake Actuating Pin	104	142917	Vent Cap Assembly
42	142888	Hi Pro Key	106	142918	Fitting O-Ring Assembly
43	142889	Spacer	108	142919	Control Arm
45	142890	Brake Disc	109	142920	Set Screw
46	142891	Bolt 1/4-20 x 1-1/2	110	142921	Filter Head
47	142892	Bolt 1/4-20 x 1	111	150820	Hose 1/2"
49	153766	Differential Assembly	112	150823	Fitting, 1/2" Beaded 90° 7/8 SAE
63	142894	Dowel Pin	113	150821	Fitting, 1/2" Beaded 60° 9/16
64	150818	Reduction Gear, 14 Teeth to 38 Teeth	117	150822	Fitting, 1/2" Beaded 90° 9/16
65	142897	Final Drive Pinion Assembly	123	150824	O Ring
67	142898	Jackshaft	124	150825	Pinch Clamp
68	142899	O-Ring	129	153771	Spring, Long
69	142900	Washer 5/8 X 1-5/32			
70	142901	Washer 7/8 X 1-1/2			
71	142902	Bolt, Hex 5/16-18 x 3.5			

NOTE: All component dimensions given in U.S. inches 1 inch = 25.4 mm

TRACTOR--MODEL NUMBER 917.275240

PUMP--BDU-10L-122

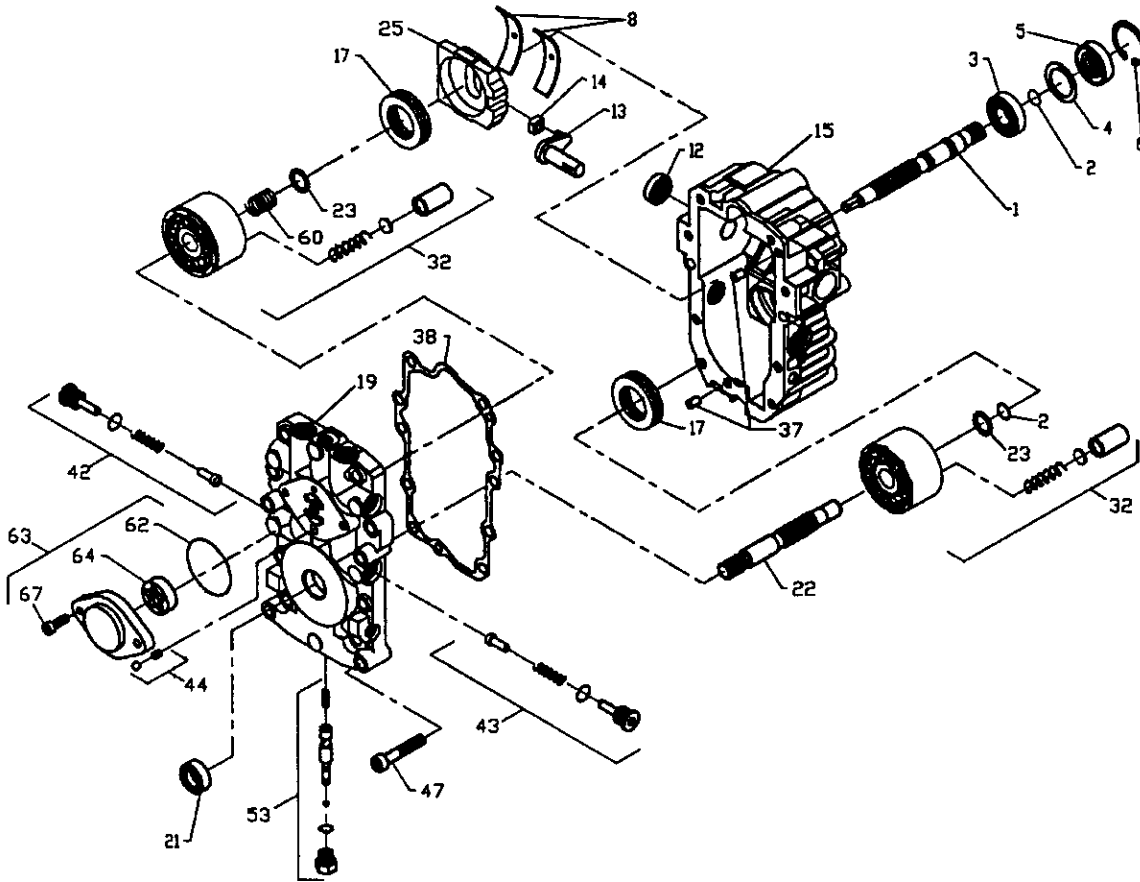

KEY PART NO.	NO.	DESCRIPTION	KEY PART NO.	NO.	DESCRIPTION
1	144569	Shaft, Pump	25	127148X	Swashplate, Variable
2	122716X	Ring, Retaining	32	142938	Block Assembly
3	122745X	Bearing, Ball	37	122786X	Pin, Stainless, Headless
4	122715X	Spacer	38	122718X	Gasket, Center Section
5	122700X	Seal, Lip	42	144578	Check Valve Kit
6	122699X	Ring, Retaining	43	144578	Check Valve Kit
8	122767X	Bearing, Cradle	44	144579	Charge Relief Kit
12	122717X	Seal, Lip	47	122752X	Screw, Socket Head, Cap
13	122748X	Arm, Trunnion	53	127153X	Bypass Valve Kit
14	122749X	Guide, Slot	60	142977	Block Spring
15	144571	Housing Kit, Transmission	62	144581	O-Ring
17	122770X	Bearing, Thrust, Ball	63	144582	Charge Pump Kit
19	153801	Center Section Kit	64	144583	Gerotor Assembly
21	122722X	Seal, Lip	67	144584	Screw, Socket Head, Cap
22	144573	Shaft, Motor	--	153769	Pump Assembly, Complete
23	142978	Washer, Block Thrust			

TRACTOR--MODEL NUMBER 917.275240
KOHLER ENGINE-MODEL NUMBER LV675, TYPE NUMBER 851509

CYLINDER HEAD, VALVE AND BREATHER

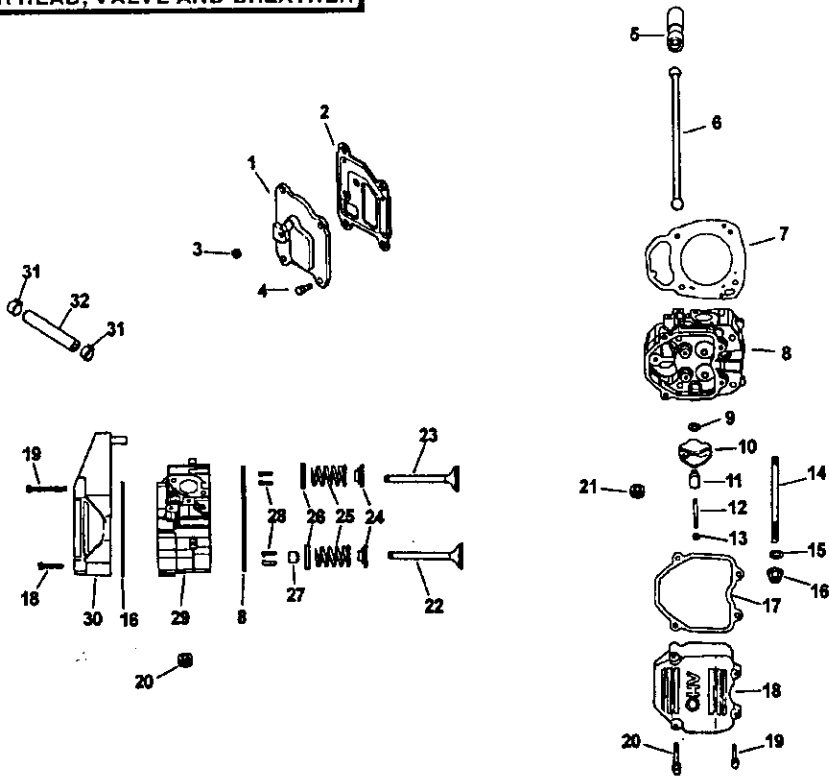

CRANKCASE

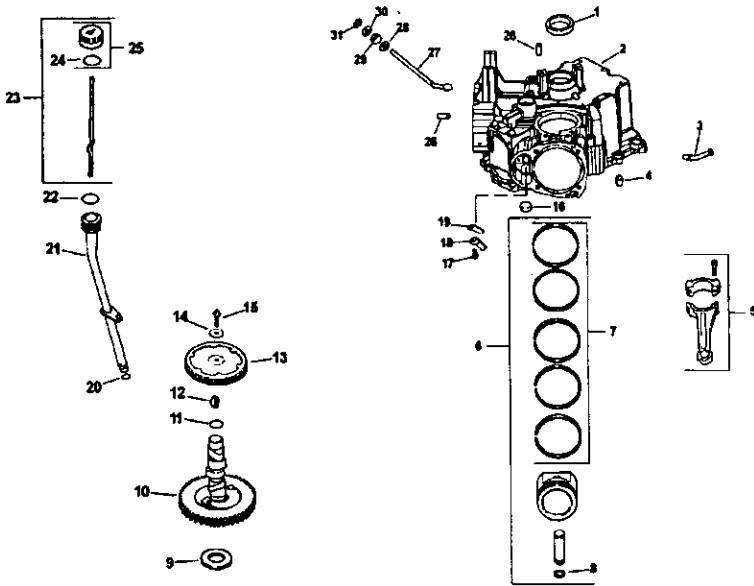

TRACTOR – MODEL NUMBER 917.275240
KOHLER ENGINE-MODEL NUMBER LV675, TYPE NUMBER 851509

HEAD/VALVE/BREATHER

KEY NO.	PART NO.	DESCRIPTION
1	66 096 06-S	Cover, breather
2	24 041 23-S	Gasket, breather
3	X-75-23-S	Plug, pipe 1/8"
4	M-645020-S	Screw, hex. flange M6x1.0x20 (4)
5	25 351 01-S	Lifter, valve (4)
6	24 411 05-S	Rod, push (4)
7	66 041 02-S	Gasket, cylinder head (2)
8	66 318 02-S	Head assembly, #2 cylinder
9	66 422 02-S	Shim (4) (A.R.)
	66 422 01-S	Shim (4) (A.R.)
	66 422 05-S	Shim (4) (A.R.)
10	25 186 01-S	Arm, rocker (4)
11	66 599 13-S	Pivot, rocker arm (4)
12	66 072 04-S	Stud, (4)
13	66 100 02-S	Nut, lock (4)
14	66 072 01-S	Stud, cylinder head (8)
15	220534-S	Washer, 5/16" (8)
16	24 100 10-S	Nut, hex. flange M8x1.25 (8)
17	66 041 04-S	Gasket, valve cover (2)
18	66 096 02-S	Cover, valve - plain
19	M-651025-S	Screw, hex. flange M6x1.0x25 (4)
20	M-651050-S	Screw, hex. flange M6x1.0x50 (4)
21	66 139 01-S	Plug, pipe 3/8" (2)
22	24 016 01-S	Valve, exhaust (Std.) (2)
	24 016 02-S	Valve, exhaust (.25) (2)
23	24 017 01-S	Valve, intake (Std.) (2)
	24 017 02-S	Valve, intake (.25) (2)
24	12 173 01-S	Cap, valve spring (4)
25	24 089 02-S	Spring, valve (4)
26	66 018 02-S	Retainer, spring (4)
27	66 032 05-S	Seal, valve stem (2)
28	12 755 03-S	Kit, retainer (4)
29	66 318 01-S	Head assembly, #1 cylinder
30	66 096 03-S	Cover, breather valve
31	X-426-3-S	Clamp, hose (2)
32	66 326 10-S	Hose, breather

CRANKCASE

KEY NO.	PART NO.	DESCRIPTION
1	24 032 01-S	Seal, oil front
2	-----	Crankcase (Use Miniblock 66 782 01)
3	24 294 13-S	Fitting
4	24 380 13-S	Pin, dowel locating (2)
5	24 067 13-S	Connecting Rod (Std.) (2)
	24 067 14-S	Connecting Rod (.25) (2)
6	24 874 09-S	Piston w/Ring Set (Std.) (2) (Includes 7,8)
	24 874 10-S	Piston w/Ring Set (.25) (2)
	24 874 11-S	Piston w/Ring Set (.50) (2)
	24 874 15-S	Piston w/Ring Set (.08) (2)
7	24 108 08-S	Ring Set (Std.) (2)
	24 108 09-S	Ring Set (.25) (2)
	24 108 10-S	Ring Set (.50) (2)
8	24 018 01-S	Retainer, piston pin (4)
9	12 422 09-S	Shim, camshaft (A.R.) red
	12 422 13-S	Shim, camshaft (A.R.) black
	12 422 07-S	Shim, camshaft (A.R.) white
	12 422 08-S	Shim, camshaft (A.R.) blue
	12 422 10-S	Shim, camshaft - yellow
	12 422 11-S	Shim, camshaft (A.R.) green
	12 422 12-S	Shim, camshaft (A.R.) gray
10	66 012 04-S	Camshaft
11	66 032 03-S	Seal, camshaft
12	X-42-2-S	Key, woodruff
13	66 093 01-S	Sprocket, camshaft
14	X-25-52-S	Washer, plain 3/4"
15	M-651020-S	Screw, hex. flange M6x1.0x20
16	52 139 09-S	Plug, cup
17	M-545010-S	Screw, hex. flange M5x0.8x10 (2)
18	66 018 01-S	Retainer, reed (2)
19	66 402 01-S	Reed, breather (2)
20	12 153 01-S	O-Ring, lower oil fill tube
21	66 123 02-S	Tube, oil fill
22	12 153 02-S	O-Ring, upper oil fill tube
23	66 038 01-S	Dipstick assembly (Includes 24,25)
24	25 755 13-S	Kit, oil fill cap (Includes 22)
25	12 153 03-S	O-Ring, dipstick
26	X-599-4-S	Pin, drive-loc (6)
27	24 144 33-S	Shaft, governor cross
28	24 468 15-S	Washer, flat 1/4"
29	28 032 09-S	Seal, oil governor shaft
30	M-931010-S	Washer, plain 9 mm
31	24 018 09-S	Ring, retainer

NOTE: All component dimensions given in U.S. inches 1 inch = 25.4 mm

TRACTOR – MODEL NUMBER 917.275240
KOHLER ENGINE-MODEL NUMBER LV675, TYPE NUMBER 851509

IGNITION/ELECTRICAL

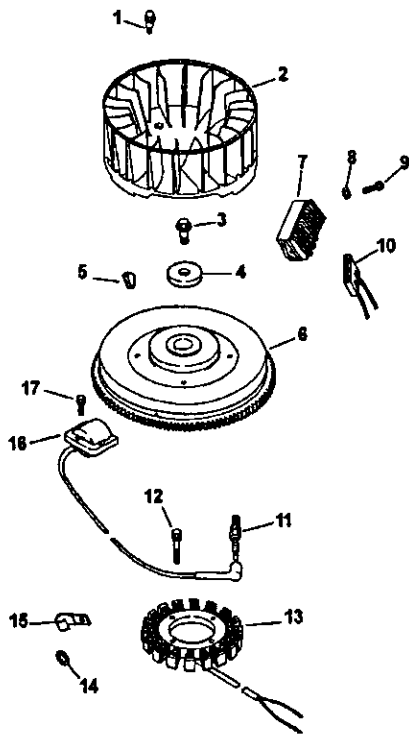

BLOWER HOUSING AND BAFFLES

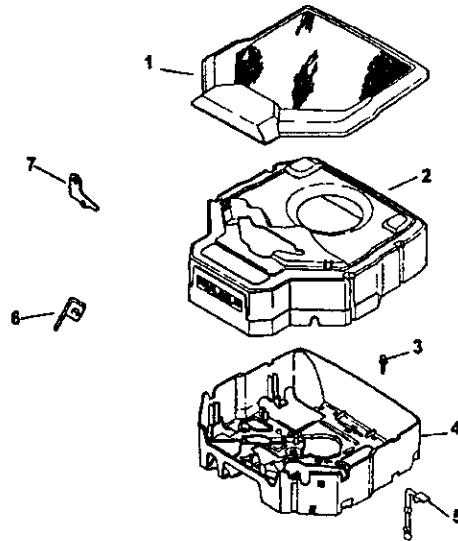

AIR INTAKE

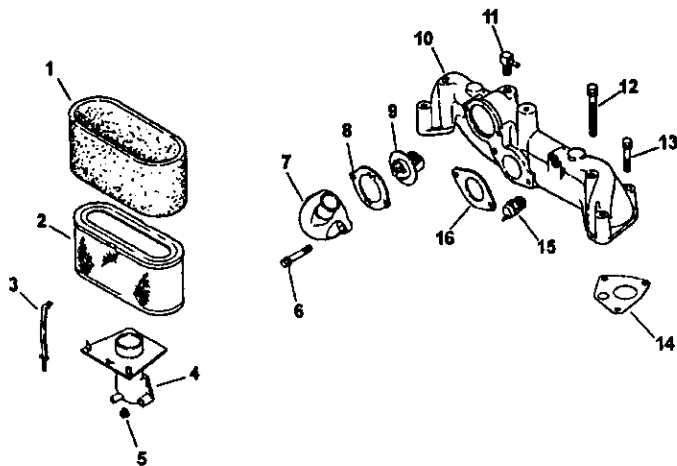

**TRACTOR – MODEL NUMBER 917.275240
 KOHLER ENGINE-MODEL NUMBER LV675, TYPE NUMBER 851509**

IGNITION/CHARGING

KEY NO.	PART NO.	DESCRIPTION
1	66 086 02-S	Screw, shoulder (4)
2	66 157 01-S	Fan
3	12 086 14-S	Screw, hex. flange M10x1.5x46
4	12 468 03-S	Washer, plain 3/8"
5	X-42-15-S	Key
6	66 025 01-S	Flywheel
7	25 403 03-S	Rectifier-regulator 15 amp
8	X-25-92-S	Washer, plain 3/16"
9	66 086 04-S	Screw, hex. ctsk. K90x2.69x25
10	236602-S	Connector (3 contact)
11	66 132 01-S	Spark Plug (2)
12	M-548025-S	Screw, hex. cap M5x0.8x25 (2)
13	66 085 01-S	Stator
14	X-25-63-S	Washer, plain 1/4"
15	235173-S	Clip, cable
16	66 584 04-S	Module, ignition #2 cylinder (2)
17	M-545020-S	Screw, thread forming M5x0.8x20 (4)

NOT ILLUSTRATED

X-22-11-S	Washer, plain 1/4" (3) (to ground rectifier-regulator)
66 176 08-S	Harness, wiring (6-pin)
25 454 03-S	Tie, cable (2)

BLOWER HOUSING & BAFFLES

KEY NO.	PART NO.	DESCRIPTION
1	66 162 02-S	Screen
2	66 081 07-S	Housing assembly, upper
3	M-645020-S	Screw, hex. flange M6x1.0x20 (8)
5	66 445 03-S	Retaining Strap
4	66 081 02-S	Housing assembly, lower
6	47 445 02-S	Strap, hanging
7	12 445 06-S	Strap, lifting

AIR INTAKE/FILTRATION

KEY NO.	PART NO.	DESCRIPTION
1	66 083 03-S	Element, precleaner
2	66 083 01-S	Element, air cleaner
3	66 445 02-S	Strap, filter element retainer
4	66 054 01-S	Elbow, air intake
6	M-651025-S	Screw, hex. flange M6x1.0x25 (2)
7	66 081 01-S	Housing, thermostat
8	66 041 01-S	Gasket, thermostat housing
9	66 453 01-S	Thermostat
10	66 164 01-S	Manifold, intake
11	45 155 01-S	Connector, hose
12	M-651090-S	Screw, hex. flange M6x1.0x90 (2)
13	M-651050-S	Screw, hex. flange M6x1.0x50 (4)
14	66 041 05-S	Gasket, intake manifold
15	66 099 02-S	Switch, temperature
16	24 041 14-S	Gasket, air cleaner base

NOT ILLUSTRATED

66 113 01-S Decal, cover on

NOTE: All component dimensions given in U.S.
 inches 1 inch = 25.4 mm

TRACTOR – MODEL NUMBER 917.275240
KOHLER ENGINE-MODEL NUMBER LV675, TYPE NUMBER 851509

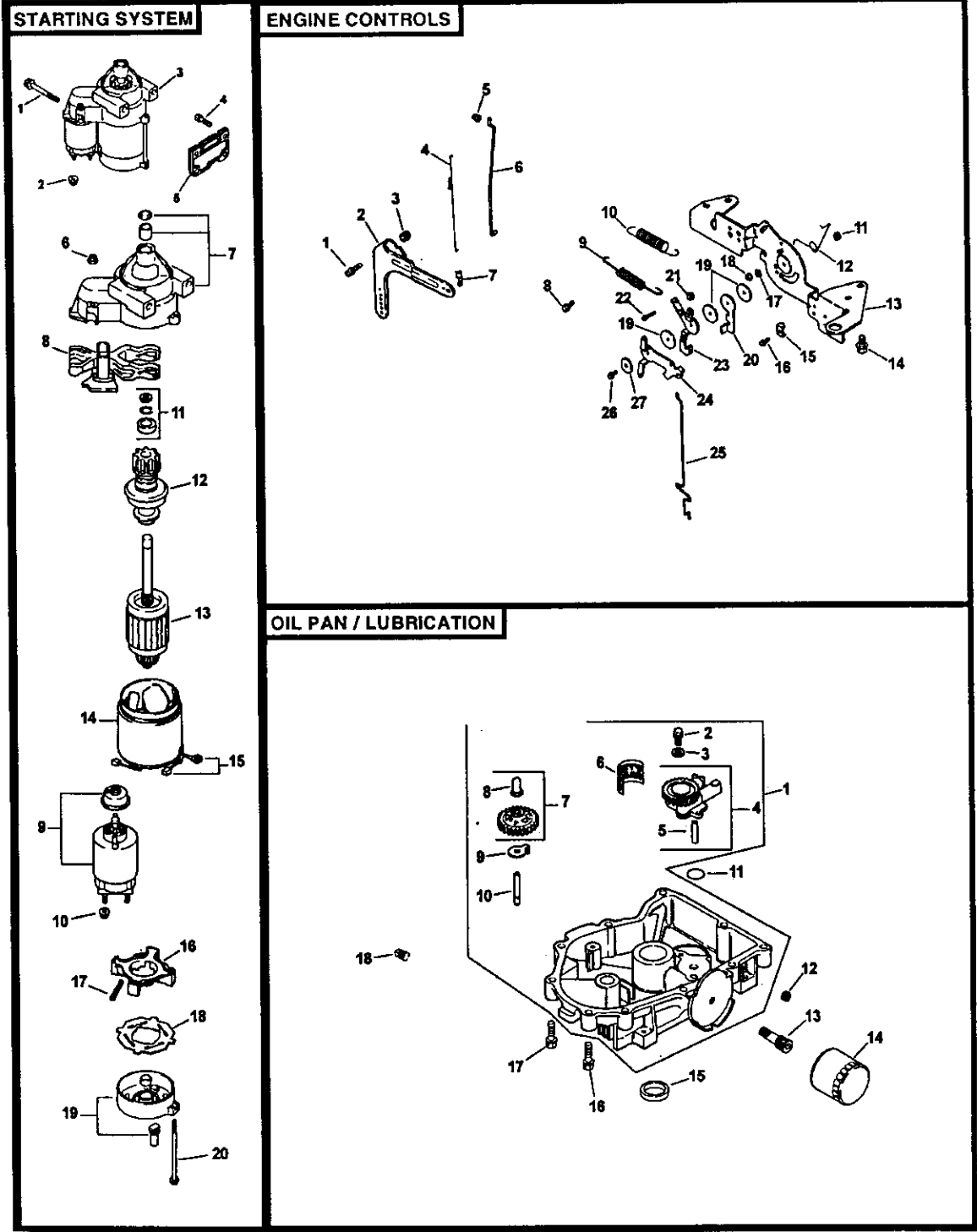

TRACTOR – MODEL NUMBER 917.275240

KOHLER ENGINE-MODEL NUMBER LV675, TYPE NUMBER 851509

STARTING SYSTEM

KEY NO.	PART NO.	DESCRIPTION
1	M-839080-S	Screw, hex. flange M8x1.25x80 (2)
2	M-841080-S	Nut, hex. flange M8x1.25
3	12 098 03-S	Starter, solenoid shift (Includes 6-20)
4	M-851030-S	Screw, hex. flange M8x1.25x30 (2)
5	66 146 10-S	Plate, starter
6	52 100 10-S	Nut, starter (2)
7	12 081 02-S	Drive, end cap
8	12 090 10-S	Lever, starter drive
9	52 435 02-S	Solenoid
10	52 100 09-S	Nut, starter
11	24 755 84-S	Kit, starter repair
12	12 239 01-S	Drive, pinion
13	12 170 03-S	Armature, starter
14	12 471 01-S	Frame
15	52 221 01-S	Kit, brush (Includes 17)
16	52 323 03-S	Holder, brush
17	52 089 09-S	Spring, brush (4)
18	52 168 01-S	Insulator
19	12 301 01-S	Commutator, end cap
20	52 211 05-S	Bolt, thru M5x0.8x99 (2)

ENGINE CONTROLS

KEY NO.	PART NO.	DESCRIPTION
1	24 211 03-S	Bolt, rd. hd. sq. neck M6x1.0x16
2	24 090 33-S	Lever, governor
3	M-641060-S	Nut, hex. flange M6x1.0
4	24 089 01-S	Spring, linkage
5	25 158 08-S	Bushing, linkage retaining
6	25 158 11-S	Linkage, throttle
7	25 158 11-S	Bushing, throttle linkage
8	M-545016-S	Screw, hex. flange M5x0.8x16
9	24 089 51-S	Spring, throttle limiter
10	24 089 47-S	Spring, governor
11	24 089 03-S	Nut, hex. M5x0.8
12	24 089 03-S	Spring, choke return
13	24 126 56-S	Bracket, control
14	M-645016-S	Screw, hex. flange M6x1.0x16 (4)
15	12 237 01-S	Clamp, cable (2)
16	24 086 43-S	Screw, (2)
17	X-20-1-S	Washer, lock
18	M-545010-S	Nut, hex. flange M5x0.8
19	24 468 01-S	Washer, (3)

KEY NO.	PART NO.	DESCRIPTION
20	24 090 07-S	Lever, throttle actuator
21	M-446030-S	Nut, hex.
22	M-403025-S	Screw, hex. cap M4x0.7x25
23	24 090 13-S	Lever, throttle control
24	24 090 05-S	Lever, choke
25	24 079 05-S	Linkage, choke
26	M-545020-S	Screw, hex. flange M5x0.8x20
27	41 468 03-S	Washer, wave

OIL PAN/LUBRICATION

KEY NO.	PART NO.	DESCRIPTION
1	24 199 07-S	Oil pan assembly (Includes 2-10)
2	M-645025-S	Screw, hex. flange M6x1.0x25 (2)
3	M-631005-S	Washer, plain 6 mm (2)
4	24 393 08-S	Oil pump assembly (Includes 5)
5	24 123 05-S	Tube, oil pickup
6	24 162 26-S	Screen, oil
7	24 043 12-S	Kit, governor gear (Includes 8)
8	12 380 01-S	Pin, governor regulating
9	52 448 02-S	Tab, locking
10	12 144 02-S	Shaft, governor gear
11	24 153 08-S	O-Ring
12	X-75-32-S	Plug, hex. ctsk. 3/8"
13	24 136 01-S	Nipple, oil filter
14	52 050 02-S	Filter, oil
15	52 032 08-S	Seal, oil (PTO end)
16	24 086 16-S	Screw, hex. flange M8x1.25x45 (9)
17	24 086 17-S	Screw, hex. flange M8x1.25x45
18	X-75-10-S	Plug, pipe 3/8"

NOTE: All component dimensions given in U.S. inches 1 inch = 25.4 mm

TRACTOR – MODEL NUMBER 917.275240
KOHLER ENGINE-MODEL NUMBER LV675, TYPE NUMBER 851509

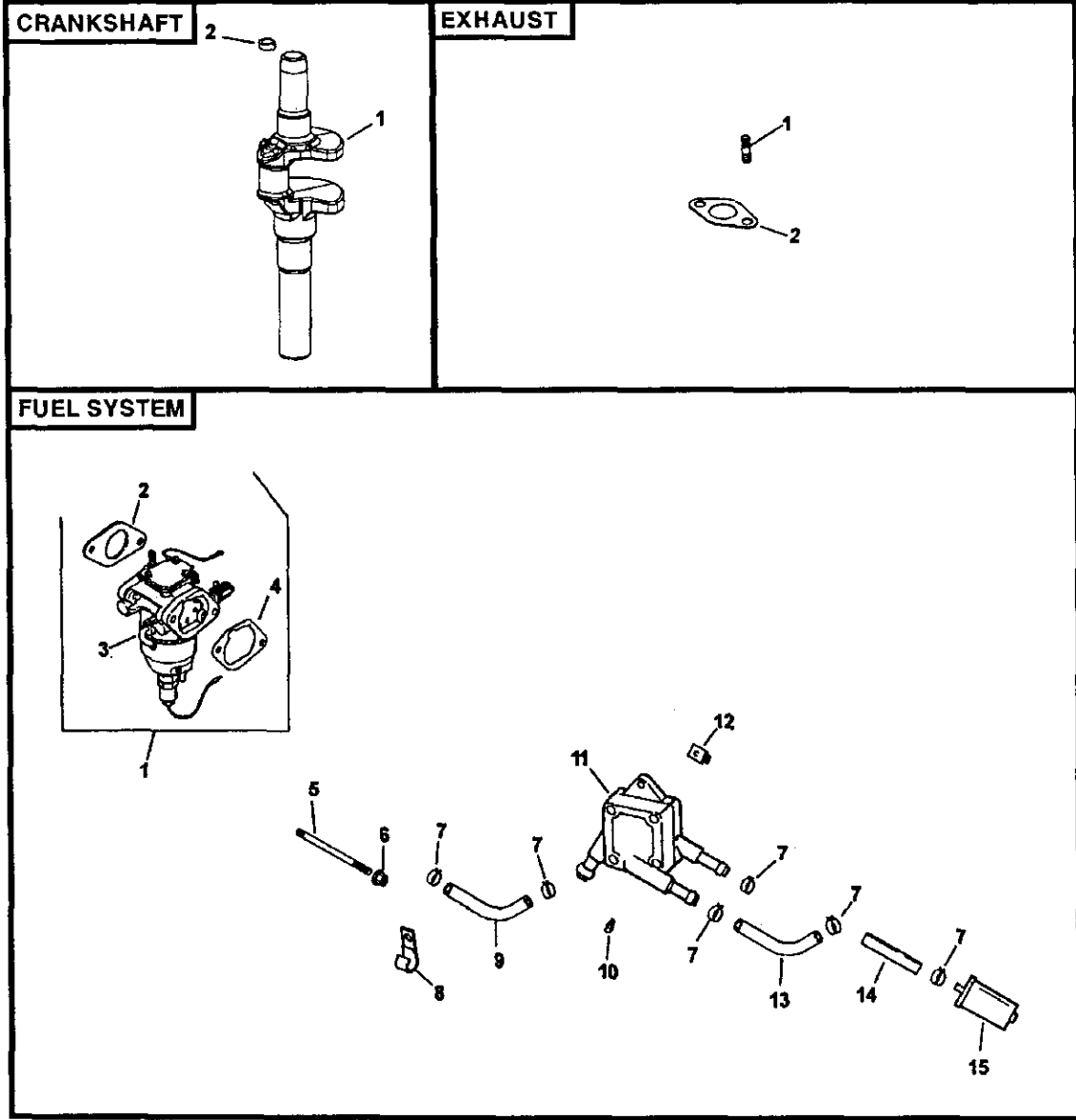

**TRACTOR – MODEL NUMBER 917.275240
 KOHLER ENGINE-MODEL NUMBER LV675, TYPE NUMBER 851509**

CRANKSHAFT

KEY NO.	PART NO.	DESCRIPTION
1	66 014 42-S	Crankshaft (Includes 2)
2	52 139 09-S	Plug, cup

EXHAUST

KEY NO.	PART NO.	DESCRIPTION
1	25 072 08-S	Stud, M6x16x33 (4)
2	24 041 02-S	Gasket, exhaust (2)

NOTE: All component dimensions given in U.S. inches 1 inch = 25.4 mm

FUEL SYSTEM

KEY NO.	PART NO.	DESCRIPTION
1	66 853 02-S	Kit, carburetor w/gaskets (Includes 2-4)
2	24 041 15-S	Gasket, carburetor
3	66 053 02	Carburetor assembly (For information only not available separately) (Includes 24 757 20-S, 24 757 07-S, 24 757 19-S & 24 757 18-S)
4	24 041 14-S	Gasket, air cleaner base
5	M-629116-S	Stud M6x1.0x116 (2)
6	M-641060-S	Nut, hex. flange M6x1.0 (2)
7	X-426-9-S	Clamp, hose (6)
8	47 154 01-S	Clip, cable
9	24 353 03-S	Line, fuel 10-5/8"
10	24 086 12-S	Screw, hex. cap. M6x1.7x18 (2)
11	24 393 16-S	Pump, fuel - pulse
12	24 100 01-S	Nut, plastic (2)
13	28 353 01-S	Line, fuel 13"
14	15 353 04-S	Line, fuel 11-1/2"
15	24 050 02-S	Filter, fuel

NOT ILLUSTRATED

28 757 07-S	Kit, solenoid repair w/gaskets
24 757 19-S	Kit, choke repair w/gaskets
24 757 18-S	Kit, overhaul w/gaskets
24 757 20-S	Kit, gasket

TRACTOR -- MODEL NUMBER 917.275240

KOHLER ENGINE-MODEL NUMBER LV675, TYPE NUMBER 851509

Coolant System

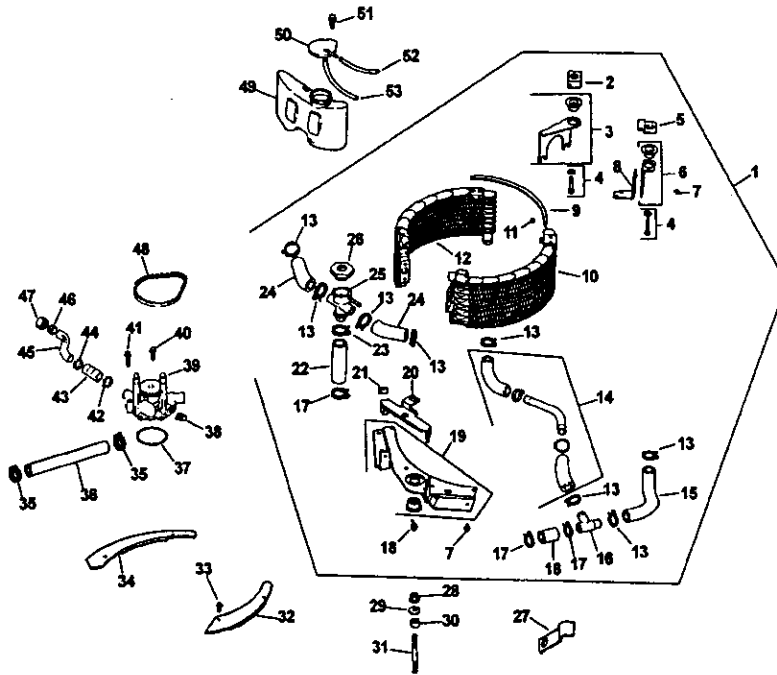

KEY NO.	PART NO.	DESCRIPTION	KEY NO.	PART NO.	DESCRIPTION
1	66 398 01-S	Radiator assembly (Includes 2-26)	30	66 431 02-S	Sleeve, intake manifold
2	66 126 24-S	Bracket, right kidney	31	66 072 02-S	Stud, radiator support
3	66 126 01-S	Bracket, solenoid	32	66 146 09-S	Plate, right core block-off
4	M-639010-S	Screw, hex. hd. M6x1.0x10 (2)	33	66 086 05-S	Screw, hex. cap M6x1.0x10 (4)
5	66 126 23-S	Bracket, left kidney	34	66 146 08-S	Plate, left core block-off
6	66 126 08-S	Bracket, "Z"	35	25 237 11-S	Clamp, hose (2)
7	66 086 09-S	Screw, (3)	36	66 326 09-S	Hose, by-pass
8	66 126 02-S	Bracket, "Z"	37	66 153 01-S	O-Ring
9	66 442 01-S	Bracket, tie	38	45 155 01-S	Connector, hose
10	66 397 02-S	Cooler assembly, right	39	66 393 01-S	Pump assembly, water
11	M-647060-S	Nut, hex. lock M6x1.0 (4)	40	M-651020-S	Screw, hex. flange M6x1.0x20 (5)
12	66 397 01-S	Cooler assembly, left	41	M-639040-S	Screw, hex. flange M6x1.0x40
13	66 237 09-S	Clamp, spring (8)	42	66 237 08-S	Clamp, water pump outlet
14	66 326 03-S	Hose assembly, 19 mm	43	66 123 01-S	Hose, crossover
15	66 326 04-S	Hose, cooler 19 mm	44	66 237 07-S	Clamp, water jacket
16	66 451 01-S	Connector, T-Barb	45	66 123 03-S	Tube, crossover
17	66 237 19-S	Clamp, hose 1"	46	66 203 01-S	Belt, water pump
18	M-639016-S	Screw, hex. hd. M6x1.0x16 (4)	47	66 065 01-S	Bottle, overflow
19	66 126 08-S	Bracket, bottom	48	24 086 42-S	Screw, hex. flange M6x1.0x16 (2)
21	66 154 02-S	U-Clip (4)	NOT ILLUSTRATED		
22	66 326 01-S	Hose, inlet 23 mm	25	454 03-S	Tie, wire (3)
23	66 237 17-S	Hose, wire clamp	66	454 01-S	Tie, wire - lower radiator hose
24	66 326 02-S	Hose, inlet 19 mm	66	782 01	Miniblock
25	66 440 01-S	Neck, filler	66	755 01-S	Gasket Set
26	66 173 01-S	Cap, pressure			
27	66 154 04-S	Clip, lower radiator hose			
28	M-647060-S	Nut, hex. lock M6x1.0			
29	X-25-52-S	Washer, plain 1/4"			

NOTE: All component dimensions given in U.S. inches 1 inch = 25.4 mm

SERVICE NOTES

SUGGESTED GUIDE FOR SIGHTING SLOPES FOR SAFE OPERATION

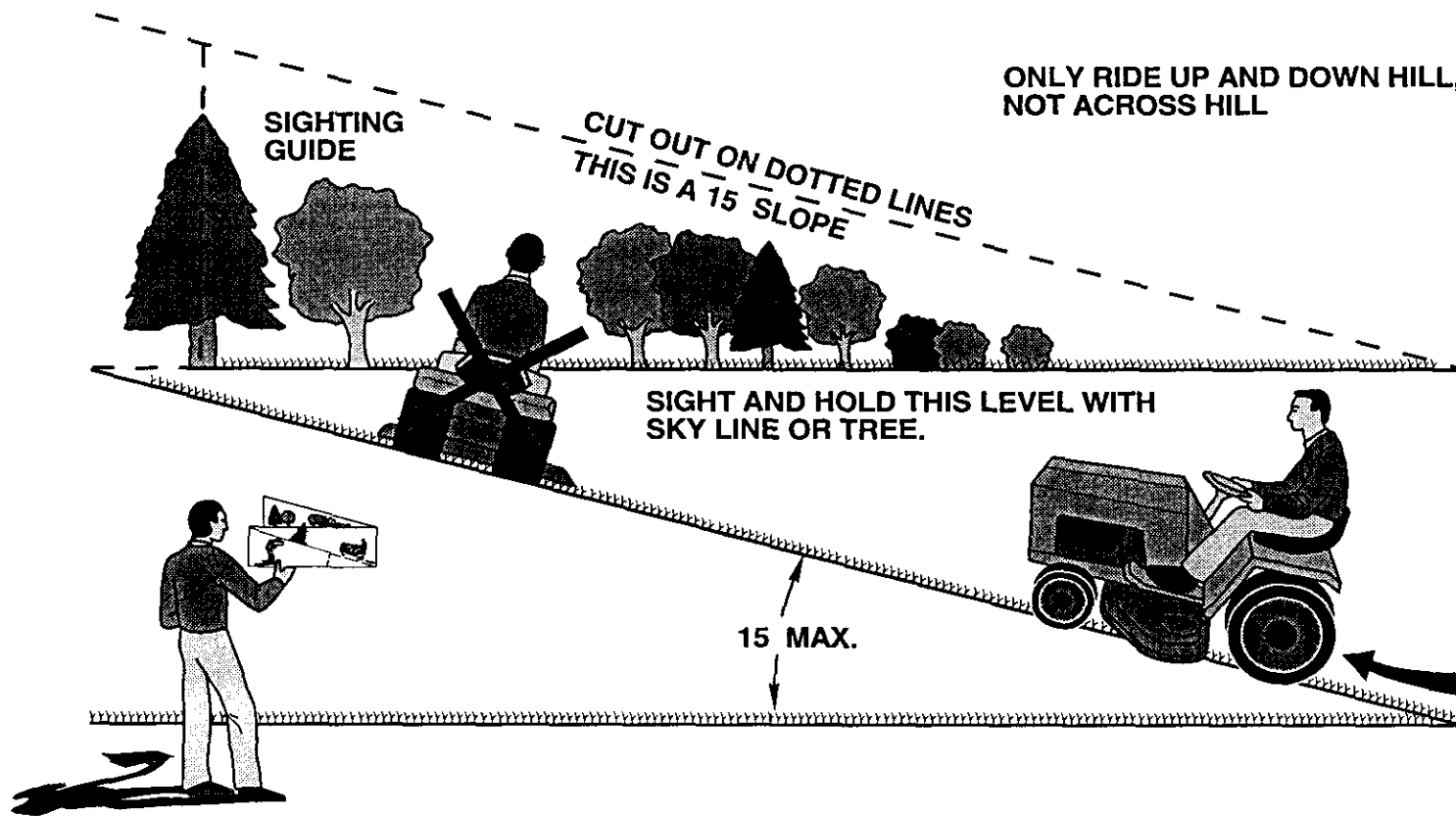

Operate your Tractor up and down the face of slopes (not greater than 15), never across the face. Make turns gradually to prevent tipping or loss of control. Exercise extreme caution when changing direction on slopes.

Get it fixed, at your home or ours!

For repair of major brand appliances **in your own home . . .**
no matter who made it, no matter who sold it!

1-800-4-MY-HOME[®] Anytime, day or night
(1-800-469-4663) (U.S.A. and Canada)
www.sears.com www.sears.ca

For repair of carry-in products like vacuums, lawn equipment, and electronics, call for the nearest **Sears Parts and Repair Center.**

1-800-488-1222 Anytime, day or night (U.S.A. only)

www.sears.com

For the replacement parts, accessories and owner's manuals that you need to do-it-yourself, call **Sears PartsDirectSM**!

1-800-366-PART 6 a.m. – 11 p.m., 7 days a week
(1-800-366-7278) (U.S.A. only)

www.sears.com/partsdirect

To purchase or inquire about a Sears Service Agreement or Sears Maintenance Agreement:

1-800-827-6655 (U.S.A.) **1-800-361-6665** (Canada)
7 a.m. – 5 p.m., CST, Mon. – Sat. 9 a.m. – 8 p.m. EST, M – F, 4 p.m. Sat.

Para pedir servicio de reparación a domicilio, y para ordenar piezas:

1-888-SU-HOGARSM
(1-888-784-6427)

Au Canada pour service en français:

1-800-LE-FOYER^{MC}
(1-800-533-6937)
www.sears.ca



© Sears, Roebuck and Co.

® Registered Trademark / TM Trademark / SM Service Mark of Sears, Roebuck and Co.

® Marca Registrada / TM Marca de Fábrica / SM Marca de Servicio de Sears, Roebuck and Co.

^{MC} Marque de commerce / ^{MD} Marque déposée de Sears, Roebuck and Co.