

# Owner's Manual

# CRAFTSMAN®

## PROFESSIONAL

## 6-1/2 in. (165 mm), 24 VOLTS PROFESSIONAL CORDLESS TRIM SAW

Model No.  
315.271030

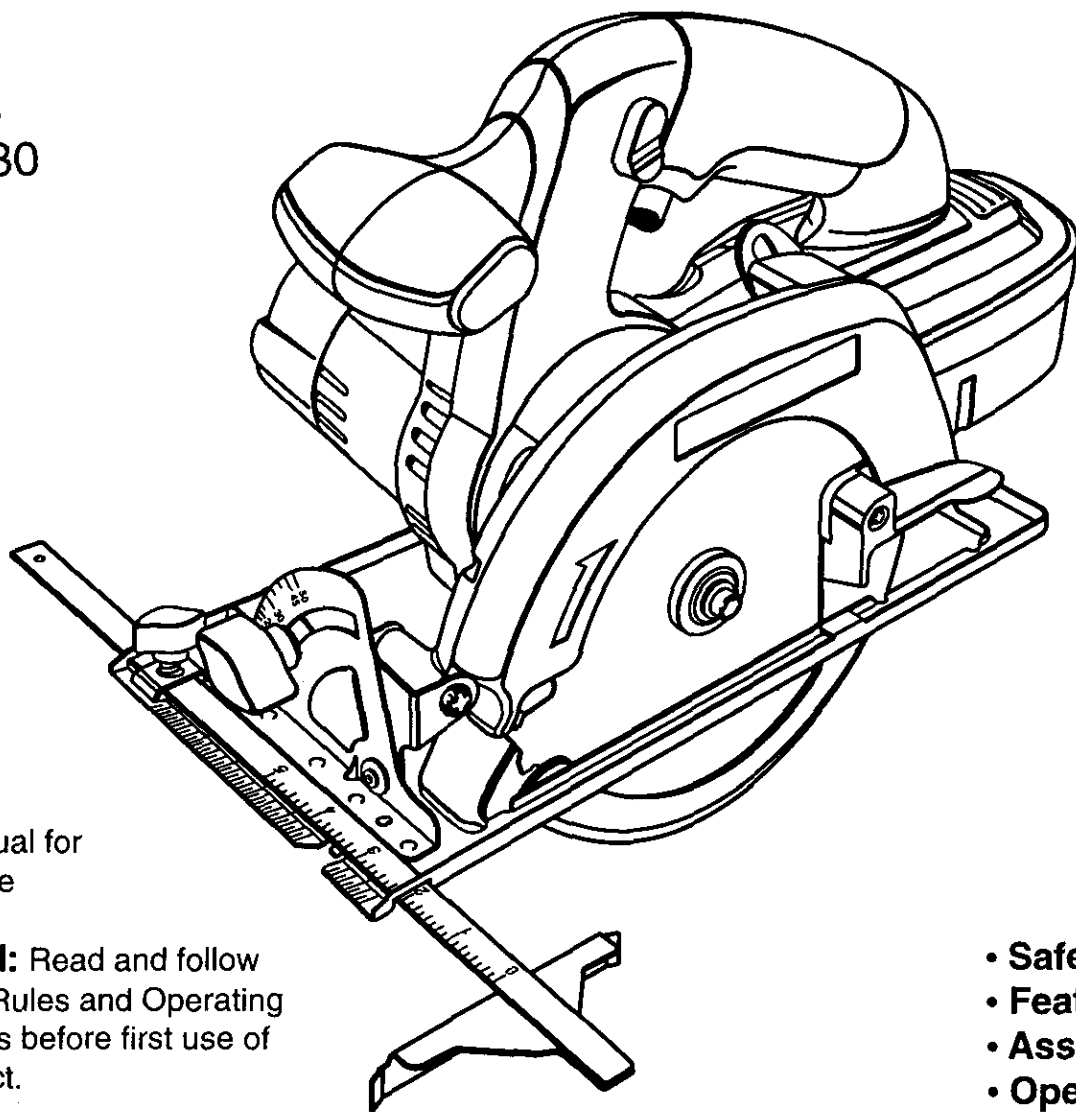

Save this manual for  
future reference

**⚠ CAUTION:** Read and follow  
all Safety Rules and Operating  
Instructions before first use of  
this product.

Customer Help Line: 1-800-932-3188

Sears Roebuck and Co., Hoffman Estates, IL 60179 USA  
Visit the Craftsman web page: [www.sears.com/craftsman](http://www.sears.com/craftsman)

- Safety
- Features
- Assembly
- Operation
- Maintenance
- Parts List



## TABLE OF CONTENTS

|   |       |
|---|-------|
| ■ General Safety Rules .....                | 2-3   |
| ■ Specific Safety Rules/Symbols .....       | 3-6   |
| ■ Features .....                            | 6-9   |
| ■ Assembly .....                            | 10-11 |
| ■ Operation .....                           | 12-19 |
| ■ Maintenance .....                         | 20    |
| ■ Accessories .....                         | 21    |
| ■ Warranty .....                            | 21    |
| ■ Exploded View And Repair Parts List ..... | 22-23 |
| ■ Parts Ordering / Service .....            | 24    |

## GENERAL SAFETY RULES



### **WARNING: Read and follow all instructions.**

Failure to follow all instructions listed below, may result in electric shock, fire and/or serious personal injury.

### **SAVE THESE INSTRUCTIONS**

#### **Work Area**

- **Keep your work area clean and well lit.** Cluttered benches and dark areas invite accidents.
- **Do not operate power tools in explosive atmospheres, such as in the presence of flammable liquids, gases, or dust.** Power tools may create sparks which may ignite the dust or fumes.
- **Keep bystanders, children, and visitors away while operating a power tool.** Distractions can cause you to lose control.

#### **Electrical Safety**

- **Do not abuse the cord. Never use the cord to carry the charger. Keep cord away from heat, oil, sharp edges, or moving parts. Replace damaged cords immediately.** Damaged cords may create a fire.
- **A battery operated tool with integral batteries or a separate battery pack must be charged only with the specified charger for the battery.** A charger that may be suitable for one type of battery may create a risk of fire when used with another battery. Use battery only with charger listed.

| <b>MODEL</b> | <b>BATTERY PACK</b>                     | <b>CHARGER</b>                          |
|--------------|---|---|
| 315.271030   | Item No. <u>9-11035</u><br>(981405-001) | Item No. <u>9-11040</u><br>(981399-001) |

- **Use battery operated tool only with specifically designated battery pack.** Use of any other batteries may create a risk of fire. Use only with battery pack listed.

#### **Personal Safety**

- **Stay alert, watch what you are doing and use common sense when operating a power tool. Do not use tool while tired or under the influence of drugs, alcohol, or medication.** A moment of inattention while operating power tools may result in serious personal injury.
- **Dress properly. Do not wear loose clothing or jewelry. Contain long hair. Keep your hair, clothing, and gloves away from moving parts.** Loose clothes, jewelry, or long hair can be caught in moving parts.
- **Avoid accidental starting. Be sure switch is in the locked or off position before inserting battery pack.** Carrying tools with your finger on the switch or inserting the battery pack into a tool with the switch on, invites accidents.
- **Remove adjusting keys or wrenches before turning the tool on.** A wrench or a key that is left attached to a rotating part of the tool may result in personal injury.
- **Do not overreach. Keep proper footing and balance at all times.** Proper footing and balance enable better control of the tool in unexpected situations.
- **Use safety equipment. Always wear eye protection.** Dust mask, nonskid safety shoes, hard hat, or hearing protection must be used for appropriate conditions.

# GENERAL SAFETY RULES

## Tool Use and Care

- **Use clamps or other practical way to secure and support the workpiece to a stable platform.** Holding the work by hand or against your body is unstable and may lead to loss of control.
- **Do not force tool. Use the correct tool for your application.** The correct tool will do the job better and safer at the rate for which it is designed.
- **Do not use tool if switch does not turn it on and off.** A tool that cannot be controlled with the switch is dangerous and must be repaired.
- **Disconnect battery pack from tool before making any adjustments, changing accessories, or storing the tool.** Such preventive safety measures reduce the risk of starting the tool accidentally.
- **Store idle tools out of the reach of children and other untrained persons.** Tools are dangerous in the hands of untrained users.
- **When battery pack is not in use, keep it away from other metal objects like: paper clips, coins, keys, nails, screws, or other small metal objects that can make a connection from one terminal to another.** Shorting the battery terminals together may cause sparks, burns, or a fire.
- **Maintain tools with care. Keep cutting tools sharp and clean.** Properly maintained tools with sharp cutting edges are less likely to bind and are easier to control.
- **Check for misalignment or binding of moving parts, breakage of parts, and any other condition that may affect the tool's operation. If damaged, have the tool serviced before using.** Many accidents are caused by poorly maintained tools.
- **Use only accessories that are recommended by the manufacturer for your model.** Accessories that may be suitable for one tool, may create a risk of injury when used on another tool.

## Service

- **Tool service must be performed by a qualified repair personnel.** Service or maintenance performed by unqualified personnel could result in a risk of injury.
- **When servicing a tool, use only identical replacement parts. Follow instructions in the Maintenance section of this manual.** Use of unauthorized parts or failure to follow Maintenance Instructions may create a risk of shock or injury.

# SPECIFIC SAFETY RULES AND/OR SYMBOLS

## Additional Rules For Safe Operation

- **Know your power tool. Read operator's manual carefully. Learn its applications and limitations, as well as the specific potential hazards related to this tool.** Following this rule will reduce the risk of electric shock, fire, or serious injury.
- **Make sure your extension cord is in good condition. When using an extension cord, be sure to use one heavy enough to carry the current your product will draw. A wire gage size (A.W.G.) of at least 16 is recommended for an extension cord 100 feet or less in length. A cord exceeding 100 feet is not recommended. If in doubt, use the next heavier gage. The smaller the gage number, the heavier the cord. An undersized cord will cause a drop in line voltage resulting in loss of power and overheating.**
- **Do not place battery tools or their batteries near fire or heat. They may explode.** Following this rule will reduce the risk of electric shock, fire, or serious personal injury.
- **Do not charge battery tool in a damp or wet location.** Following this rule will reduce the risk of electric shock, fire, or serious personal injury.
- **Your battery tool should be charged in a location where the temperature is more than 50°F but less than 100°F.** Following this rule will reduce the risk of electric shock, fire, or serious personal injury.
- **Under extreme usage or temperature conditions, battery leakage may occur. If liquid comes in contact with your skin, wash immediately with soap and water, then neutralize with lemon juice or vinegar. If liquid gets into your eyes, flush them with clean water for at least 10 minutes, then seek immediate medical attention.** Following this rule will reduce the risk of serious personal injury.

## Important Rules For Battery Tools

- **Battery tools do not have to be plugged into an electrical outlet; therefore, they are always in operating condition. Be aware of possible hazards when not using your battery tool or when changing accessories.** Following this rule will reduce the risk of electric shock, fire, or serious personal injury.

## SPECIFIC SAFETY RULES AND/OR SYMBOLS

### Additional Specific Safety Rules

- **DANGER! Keep hands away from cutting area and blade. Keep your second hand on auxiliary handle or motor housing.** If both hands are holding the saw, they cannot be cut by the blade.
- **Keep your body positioned to either side of the saw blade, but not in line with the saw blade.** KICKBACK could cause the saw to jump backwards. *See Pages 14 and 15.*
- **Do not reach underneath the work.** The guard cannot protect you from the blade below the work.
- **Check the lower guard for proper closing before each use. Do not operate saw if lower guard does not move freely and close instantly. Never clamp or tie the lower guard into the open position .** If saw is accidentally dropped, lower guard may be bent. Raise lower guard with the lower blade guard handle and make sure it moves freely and does not touch the blade or any other part, in all angles and depths of cut.
- **Check the operation and condition of the lower guard spring. If the guard and the spring are not operating properly, they must be serviced before use.** Lower guard may operate sluggishly due to damaged parts, gummy deposits, or a buildup of debris.
- **Lower guard should be retracted manually only for special cuts such as “Pocket Cuts” and “Compound Cuts”.** Raise lower guard by lower blade guard handle. As soon as blade enters the material, lower guard must be released. For all other sawing, the lower guard should operate automatically.
- **Always observe that the lower guard is covering the blade before placing saw down on bench or floor.** An unprotected, coasting blade will cause the saw to walk backwards, cutting whatever is in its path. Be aware of the time it takes for the blade to stop after switch is released.
- **NEVER hold piece being cut in your hands or across your leg.** It is important to support the work properly to minimize body exposure, blade binding, or loss of control.
- **Hold tool by insulating gripping surfaces when performing an operation where the cutting tool may contact hidden wiring.** Contact with a “live” wire will also make exposed metal parts to the tool “live” and shock the operator.
- **When ripping always use a rip fence or a straight edge guide.** This improves the accuracy of cut and reduces the chance of blade binding.
- **Always use blade with correct size and shape (diamond vs. round) arbor holes.** Blades that do not match the mounting hardware of the saw will run eccentrically, causing loss of control.
- **Never use damaged or incorrect blade washers or bolts.** The blade washers and bolt were specially designed for your saw, for optimum performance and safety of operation.
- **Causes and Operator Prevention of Kickback:**

Kickback is a sudden reaction to a pinched, bound, or misaligned saw blade, causing an uncontrolled saw to lift up and out of the workpiece toward the operator.

When the blade is pinched or bound tightly by the kerf closing down, the blade stalls and the motor reaction drives the unit rapidly back toward the operator.

If the blade becomes twisted or misaligned in the cut, the teeth at the back edge of the blade can dig into the top surface of the wood causing the blade to climb out of the kerf and jump back toward the operator.

Kickback is a result of tool misuse and/or incorrect operating procedures or conditions and can be avoided by taking proper precautions as given below:
- **Maintain a firm grip on the saw and position your body and arm in a way that allows you to resist KICKBACK forces.** KICKBACK forces can be controlled by the operator, if proper precautions are taken.
- **When blade is binding, or when interrupting a cut for any reasons, release the trigger and hold the saw motionless in the material until the blade comes to a complete stop. Never attempt to remove the saw from the work or pull the saw backward while the blade is in motion or KICKBACK may occur.** Investigate and take corrective actions to eliminate the cause of blade binding.
- **When restarting a saw in the workpiece, center the saw blade in the kerf and check that teeth are not engaged into the material.** If saw blade is binding, it may walk up or KICKBACK from the workpiece as the saw is restarted.
- **Support large panels to minimize the risk of blade pinching and KICKBACK.** Large panels tend to sag under their own weight. Supports must be placed under the panel on both sides, near the line of cut and near the edge of the panel.
- **Do not use dull or damaged blades.** Unsharpened or improperly set blades produce narrow kerf causing excessive friction, blade binding, and KICKBACK.
- **Blade depth and bevel adjusting locking levers must be tight and secure before making cut.** If blade adjustment shifts while cutting, it will cause binding and KICKBACK.
- **Use extra caution when making a “Pocket Cut” into existing walls or other blind areas.** The protruding blade may cut objects that can cause KICKBACK.

# SPECIFIC SAFETY RULES AND/OR SYMBOLS

## Important Safety Instructions For Charger

- **Save these instructions.** This manual contains important safety and operating instructions for battery charger item number 9-11040 (981399-001). Following this rule will reduce the risk of electric shock, fire, or serious personal injury.
  - **Before using battery charger, read all instructions and cautionary markings in this manual, on battery charger, and product using battery charger.** Following this rule will reduce the risk of electric shock, fire, or serious personal injury.
  - **To reduce the risk of injury, charge only nickel-cadmium and nickel metal hydride type rechargeable batteries. Other types of batteries may burst causing personal injury and damage.** Following this rule will reduce the risk of electric shock, fire, or serious personal injury.
  - **Do not expose charger to rain or snow.** Following this rule will reduce the risk of electric shock, fire, or serious personal injury.
  - **Use of an attachment not recommended or sold by the battery charger manufacturer may result in a risk of fire, electric shock, or injury to persons.** Following this rule will reduce the risk of electric shock, fire, or serious personal injury.
  - **To reduce the risk of damage to charger body and cord, pull by charger plug rather than cord when disconnecting charger.** Following this rule will reduce the risk of serious personal injury.
  - **Make sure cord is located so that it will not be stepped on, tripped over, or otherwise subjected to damage or stress.** Following this rule will reduce the risk of electric shock, fire, or serious personal injury.
  - **An extension cord should not be used unless absolutely necessary.** Use of improper extension cord could result in a risk of fire and electric shock. If extension cord must be used, make sure:
    - a. That pins on plug of extension cord are the same number, size and shape as those of plug on charger.
    - b. That extension cord is properly wired and in good electrical condition; and
    - c. That wire size is large enough for AC ampere rating of charger as specified below:

|                    |     |     |      |
|--------------------|-----|-----|------|
| Cord Length (Feet) | 25' | 50' | 100' |
| Cord Size (AWG)    | 16  | 16  | 16   |
- Note:** AWG = American Wire Gage
- **Do not operate charger with a damaged cord or plug. If damaged, have replaced immediately by a qualified serviceman.** Following this rule will reduce the risk of electric shock, fire, or serious personal injury.

- **Do not operate charger if it has received a sharp blow, been dropped, or otherwise damaged in any way; take it to a qualified serviceman.** Following this rule will reduce the risk of electric shock, fire, or serious personal injury.
- **Do not disassemble charger; take it to a qualified serviceman when service or repair is required. Incorrect reassembly may result in a risk of electric shock or fire.** Following this rule will reduce the risk of electric shock, fire, or serious personal injury.
- **To reduce the risk of electric shock, unplug charger from outlet before attempting any maintenance or cleaning. Turning off controls will not reduce this risk.** Following this rule will reduce the risk of electric shock, fire, or serious personal injury.
- **Do not use charger outdoors.** Following this rule will reduce the risk of electric shock, fire, or serious personal injury.
- **Disconnect charger from power supply when not in use.** Following this rule will reduce the risk of electric shock, fire, or serious personal injury.
- **Save these instructions. Refer to them frequently and use them to instruct others who may use this tool. If you loan someone this tool, loan them these instructions also.** Following this rule will reduce the risk of electric shock, fire, or serious personal injury.

**⚠ DANGER: RISK OF ELECTRIC SHOCK. DO NOT TOUCH UNINSULATED PORTION OF OUTPUT CONNECTOR OR UNINSULATED BATTERY TERMINAL.**

**⚠ WARNING:** Some dust created by power sanding, sawing, grinding, drilling, and other construction activities contains chemicals known to cause cancer, birth defects or other reproductive harm. Some examples of these chemicals are:

- lead from lead-based paints,
- crystalline silica from bricks and cement and other masonry products, and
- arsenic and chromium from chemically-treated lumber.

Your risk from these exposures varies, depending on how often you do this type of work. To reduce your exposure to these chemicals: work in a well ventilated area, and work with approved safety equipment, such as those dust masks that are specially designed to filter out microscopic particles.

## SYMBOLS

| SYMBOL  | NAME                                    | DESIGNATION/EXPLANATION  |
|---|---|--|
| V   | Volts                                   | Voltage  |
| A   | Amperes                                 | Current  |
| Hz  | Hertz                                   | Frequency (cycles per second)  |
| min   | Minutes                                 | Time   |
| ~   | Alternating Current                     | Type or a characteristic of current  |
| ==  | Direct Current                          | Type or a characteristic of current  |
| $n_0$   | No Load Speed                           | Rotational speed, at no load   |
| .../min   | Revolutions or Reciprocation Per Minute | Revolutions, strokes, surface speed, orbits etc. per minute                          |
|  | Safety Alert Symbol                     | Indicates danger, warning or caution. It means attention!!! Your safety is involved. |

## FEATURES

### DEFINITIONS

- A) **DANGER:** Failure to obey a safety warning will result in serious injury to yourself or to others. Always follow the safety precautions to reduce the risk of fire, electric shock and personal injury.
- B) **WARNING:** Failure to obey a safety warning can result in serious injury to yourself or to others. Always follow the safety precautions to reduce the risk of fire, electric shock and personal injury.
- C) **CAUTION:** Failure to obey a safety warning may result in property damage or personal injury to yourself or to others. Always follow the safety precautions to reduce the risk of fire, electric shock and personal injury.
- D) **NOTE:** Advises you of information or instructions vital to the operation or maintenance of the equipment.

### WARNING:



The operation of any power tool can result in foreign objects being thrown into your eyes, which can result in severe eye damage. Before beginning power tool operation, always wear safety goggles or safety glasses with side shields and a full face shield when needed. We recommend Wide Vision Safety Mask for use over eyeglasses or standard safety glasses with side shields, available at Sears Retail Stores.

# FEATURES

## KNOW YOUR TRIM SAW

See Figure 1.

Before attempting to use your trim saw, familiarize yourself with all operating features and safety requirements.

Features include easily operated bevel cut and depth of cut adjustment mechanisms; positive 0° bevel stop; spindle lock; and blade wrench storage area.

**WARNING:** Carefully read through this entire owner's manual before using your new trim saw. Pay close attention to the Rules For Safe Operation, Warnings and Cautions. If you use your trim saw properly and only for what it is intended, you will enjoy years of safe, reliable service.

Your trim saw has been shipped completely assembled except for the blade. Inspect it carefully to make sure no breakage or damage has occurred during shipping. If any parts are damaged or missing, contact your nearest Sears Retail Store to obtain replacement parts before attempting to operate saw. A blade, blade wrench (5 mm hex key), rip guide (edge guide) and this owner's manual are also included.

**WARNING:** Do not allow familiarity with your saw to make you careless. Remember that a careless fraction of a second is sufficient to inflict severe injury.

## SWITCH

Your saw is equipped with a lock-off button which reduces the possibility of accidental starting. The lock-off button is located on the handle above the switch trigger. You must depress the lock-off button in order to pull the switch trigger. The lock resets each time the trigger is released. **Note:** You can depress the lock-off button from either the left or right side.

## APPLICATIONS

(Use only for the purposes listed below)

- Cutting all types of wood products (lumber, plywood, paneling).

**WARNING:** If any parts are missing, do not operate your saw until the missing parts are replaced. Failure to do so could result in possible serious personal injury.

## PRODUCT SPECIFICATIONS:

|                      |  |
|----------------------|--|
| <b>TRIM SAW</b>      | <b>315.271030</b>                        |
| Blade Diameter       | 6-1/2 in. (165 mm)                       |
| Blade Arbor          | 5/8 in. (16 mm)                          |
| Cutting Depth at 90° | 2-1/8 in. (54 mm)                        |
| Cutting Depth at 45° | 1-5/8 in. (42 mm)                        |
| No load Speed        | 2,500 RPM                                |
| Motor                | 24 Volts DC                              |
| <b>CHARGER</b>       | <b>ITEM NO. 9-11040<br/>(981399-001)</b> |
| Input                | 120 v, 60 Hz, AC only                    |
| Charging Voltage     | 9.6 - 24 Volts                           |
| Charge Rate          | 1 Hour                                   |
| <b>BATTERY PACK</b>  | <b>ITEM NO. 9-11035<br/>(981405-001)</b> |

# FEATURES

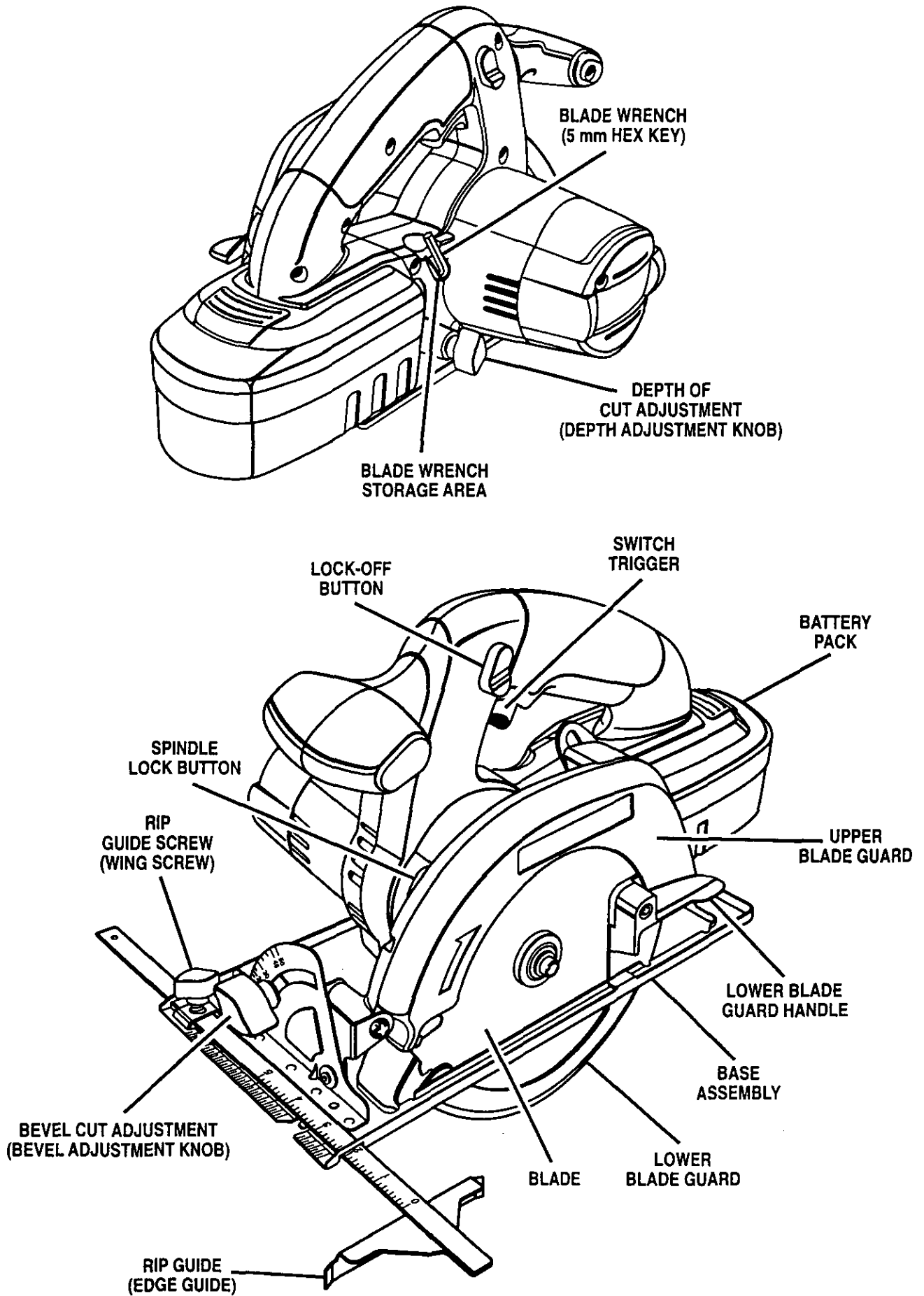

Fig. 1



# FEATURES

## LED FUNCTION OF CHARGER

YELLOW LIGHT "ON" AND RED LIGHT FLASHING, INDICATES DEFECTIVE BATTERY PACK

CHARGER

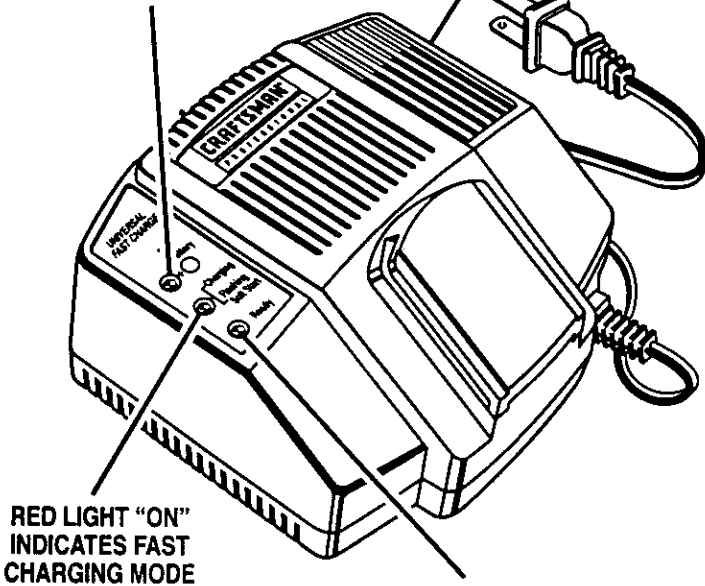

RED LIGHT "ON" INDICATES FAST CHARGING MODE

GREEN LIGHT "ON" INDICATES FULLY CHARGED AND SLOW CHARGING TO MAINTAIN BATTERY PACK

Fig. 2

## BATTERY PACK SHOWN ATTACHED TO CHARGER

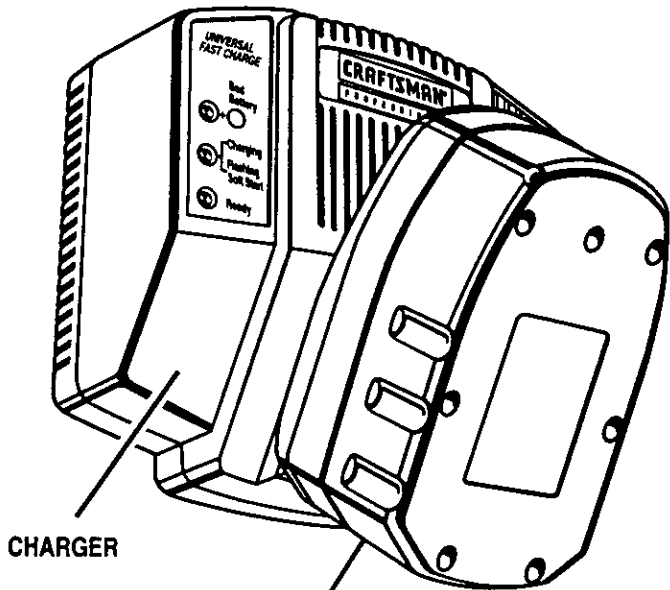

CHARGER

BATTERY PACK SHOWN IN CHARGER

Fig. 3

## MOUNTING CHARGER

See Figure 4.

Your charger has a "key hole" hanging feature for convenient, space saving storage. Therefore, if desired, you can mount your charger to a wall. Screws should be installed so that center distances are 4-1/8 inches apart.

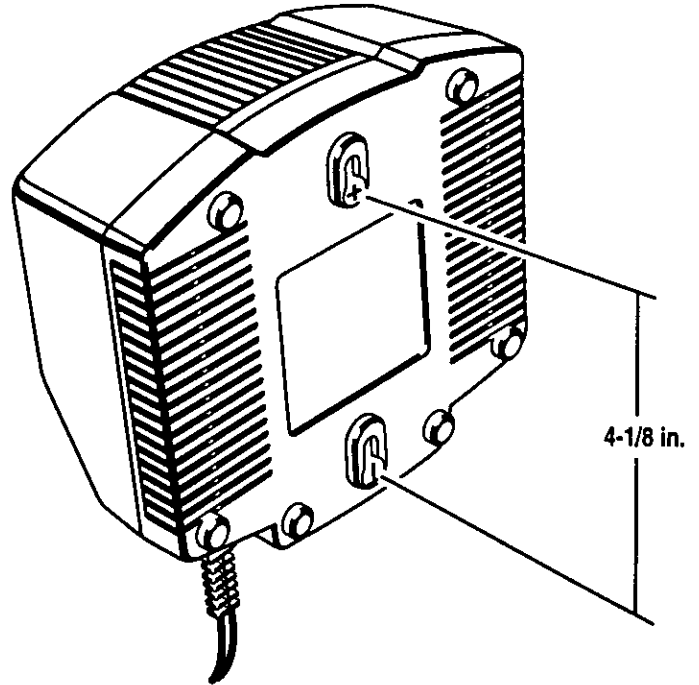

BACK SIDE OF CHARGER

Fig. 4

## ASSEMBLY

**⚠ WARNING:** Always remove battery pack from your saw when you are assembling parts, making adjustments, assembling or removing blades, cleaning, or when not in use. Removing battery pack will prevent accidental starting that could cause serious personal injury.

**Note:** Your saw is shipped with the battery pack attached.

### TO REMOVE BATTERY PACK

See Figure 5.

- Depress latch located on front of battery pack (1) to release battery pack.
- Pull on battery pack (2) to remove from saw.

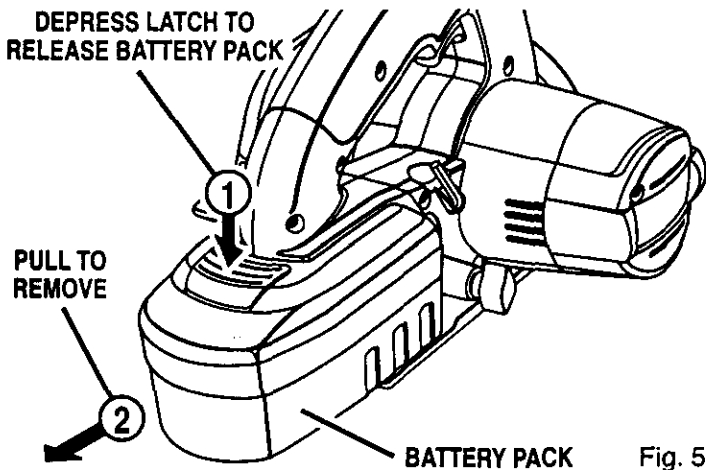

### TO ASSEMBLE BLADE

See Figure 6.

**⚠ WARNING:** A 6-1/2 in. (165 mm) blade is the maximum blade capacity of your saw. Never use a blade that is too thick to allow outer blade washer to engage with the flats on the spindle. Larger blades will come in contact with the blade guard, while thicker blades will prevent blade screw from securing blade on spindle. Either of these situations could result in a serious accident.

- Remove battery pack from saw.

**⚠ WARNING:** Failure to remove battery pack from saw could result in accidental starting causing possible serious personal injury.

- Locate latch on end of battery pack and depress to release battery pack from your saw. See Figure 5.

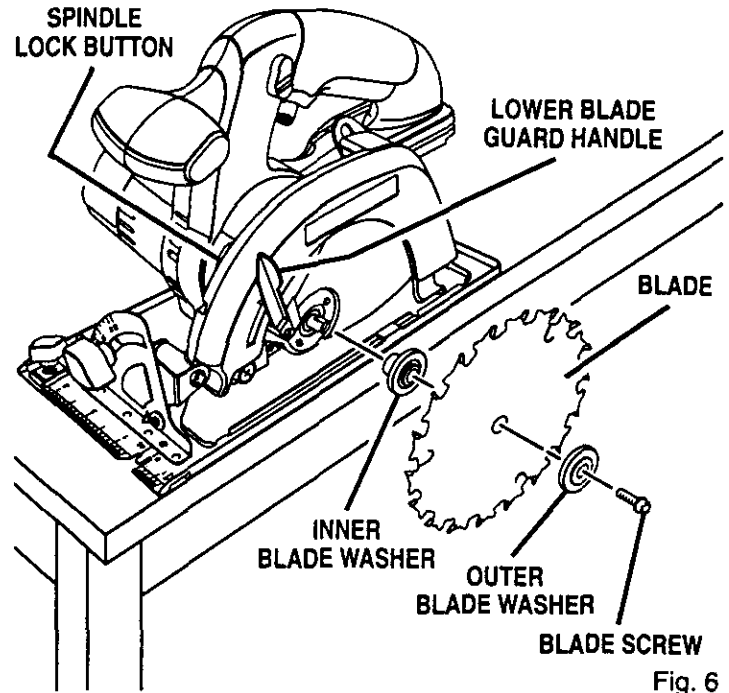

- Remove blade wrench (5 mm hex key) from storage area. See Figure 1.
- Depress spindle lock button and remove blade screw and outer blade washer. See Figure 6.  
**Note:** Turn blade screw clockwise to remove.
- Wipe a drop of oil onto inner blade washer and outer blade washer where they contact blade.

**⚠ WARNING:** If inner blade washer has been removed, replace it before placing blade on spindle. Failure to do so could cause an accident since blade will not tighten properly.

- Fit saw blade inside lower blade guard and onto spindle.  
**Note:** The saw teeth point upward at the front of saw as shown in figure 6.
- Replace outer blade washer.
- Depress spindle lock button, then replace blade screw. Tighten blade screw securely.  
**Note:** Turn blade screw counterclockwise to tighten.
- Return blade wrench to storage area.

**REMEMBER:** Never use a blade that is too thick to allow the outer blade washer to engage with the flats on the spindle.

## ASSEMBLY

### TO REMOVE BLADE

See Figure 7.

- Remove battery pack from saw.

**⚠ WARNING:** Failure to remove battery pack from saw could result in accidental starting causing possible serious personal injury.

- Remove blade wrench from storage area. See Figure 1.
- Position saw as shown in figure 7, depress spindle lock button, and remove blade screw.

**Note:** Turn blade screw clockwise to remove.

- Remove outer blade washer. See Figure 6.

**Note:** Blade can be removed at this point.

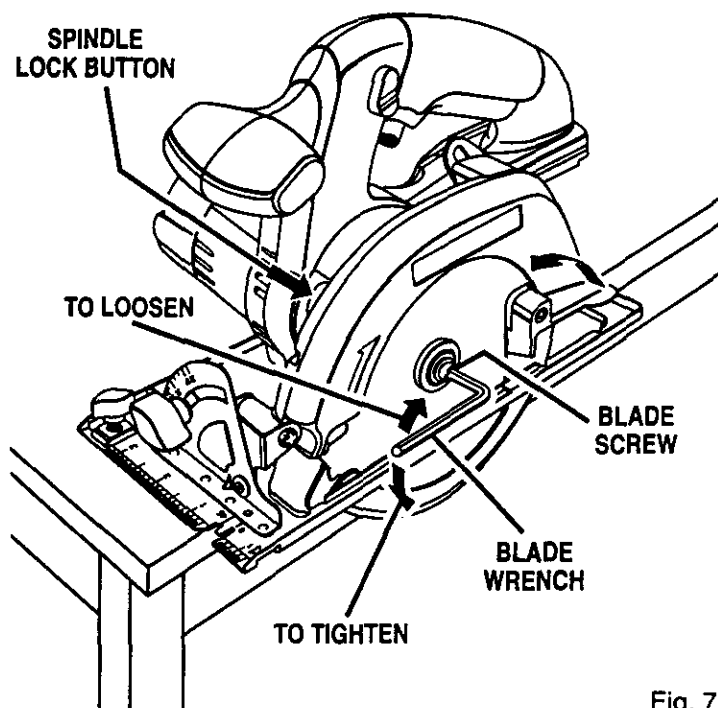

Fig. 7

### TO ATTACH BATTERY PACK TO TRIM SAW

See Figure 8.

**Note:** Battery pack is shipped in a low charge condition. Therefore, it must be charged prior to use. Refer to page 12, "CHARGING BATTERY PACK" for charging instructions.

- Align raised ribs on battery pack with grooves on bottom of saw, then attach battery pack to saw as shown in figure 8.
- Make sure the latch on battery pack snaps into place and battery pack is secured to saw before beginning operation.

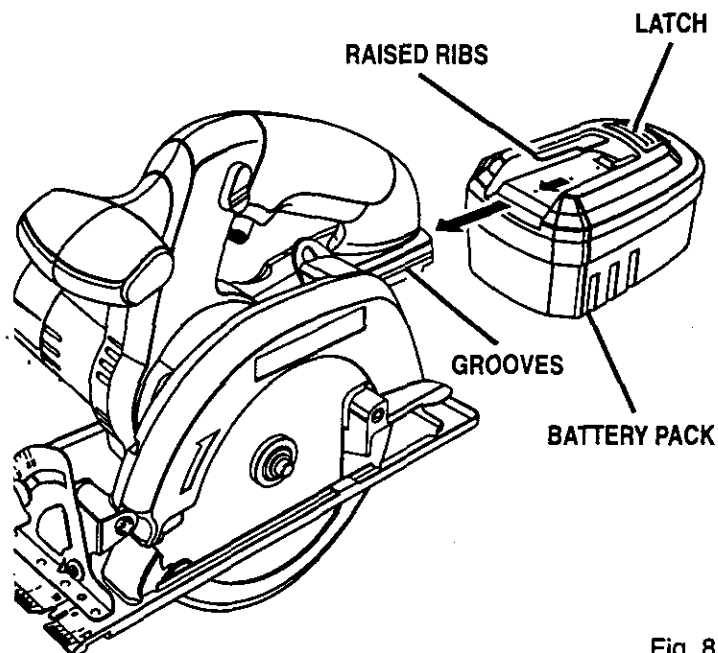

Fig. 8

**⚠ CAUTION:** When attaching battery pack to your saw, be sure raised ribs and grooves align properly and latch snaps into place properly. Improper assembly can cause damage to saw and battery pack.

## OPERATION

- ⚠ WARNING:** Always wear safety goggles or safety glasses with side shields when operating tools. Failure to do so could result in objects being thrown into your eyes, resulting in possible serious injury.

### CHARGING BATTERY PACK

The battery pack for this tool has been shipped in a low charge condition to prevent possible problems. Therefore, you should charge it until light on front of charger changes from red to green.

**Note:** Batteries will not reach full charge the first time they are charged. Allow several cycles (cutting followed by recharging) for them to become fully charged.

### TO CHARGE

- Charge battery pack only with the charger provided.
- **Make sure power supply is normal household voltage, 120 volts, 60 Hz, AC only.**
- Connect charger to power supply.
- Attach battery pack to charger by aligning raised ribs on battery pack with grooves in charger, then slide battery back onto charger. *See Figure 9.*

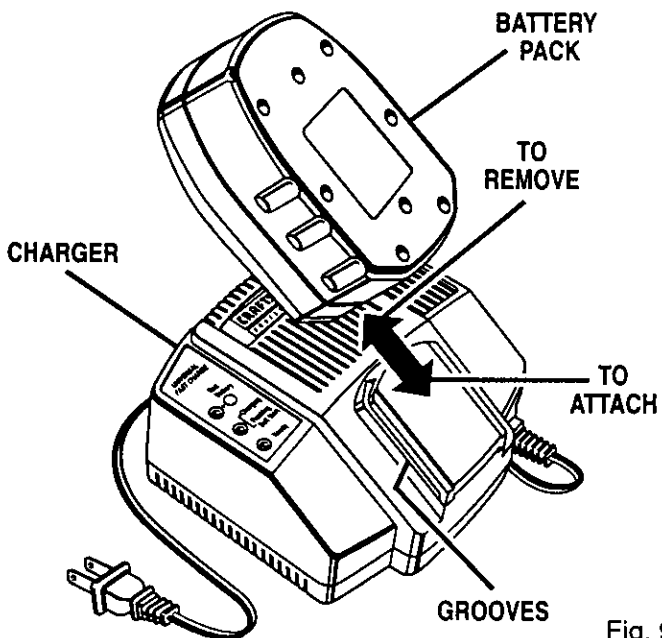

Fig. 9

- Red light should turn on. Red light indicates fast charging mode.  
If red light is flashing, this indicates battery pack is deeply discharged or hot.  
If battery pack is hot, red light should become steady after battery pack has cooled down.  
If battery pack is deeply discharged, red light should become steady after voltage has increased, normally within 60 minutes.

If after one hour red light is still flashing, this indicates a defective battery pack and should be replaced.

Green light on indicates battery pack is fully charged and slow charging to maintain battery pack.

Yellow light on and red light flashing indicates defective battery pack. Return battery pack to your nearest Sears Repair Center for checking or replacing.

- When your battery pack becomes fully charged, the red light will turn **OFF** and the green light will turn **ON**.
- After normal usage, 1 hour of charging time is required to be fully charged. A minimum charge time of 1-1/2 hours is required to recharge a completely discharged tool.
- The battery pack will become slightly warm to the touch while charging. This is normal and does not indicate a problem.
- **Do not** place charger in an area of extreme heat or cold. It will work best at normal room temperature.
- When the batteries become fully charged, unplug charger from power supply and remove the battery pack.

### LED FUNCTION OF CHARGER

#### LED WILL BE LIGHTED TO INDICATE STATUS OF CHARGER AND BATTERY PACK:

- Red LED Lighted = Fast Charging Mode.
- Green LED Lighted = Fully Charged And Slow Charging To Maintain Battery Pack.
- Red LED Flashing = Hot Or Deeply Discharged Battery Pack. Also Defective Battery Pack After 1 Hour.
- Yellow LED Lighted and Red LED Flashing = Defective Battery Pack.

### IMPORTANT INFORMATION FOR RECHARGING HOT BATTERIES

Under extreme continuous use, the batteries in your battery pack will become hot. You should let a hot battery pack cool down for approximately 1 hour before attempting to recharge. When the battery pack becomes discharged and is hot, this will cause the red light on your battery charger to flash. When battery pack cools down, red light will glow continuously indicating fast charging mode, 1 hour charge time. Once the battery pack cools down, it will recharge battery pack in fast charging mode as normal.

**Note:** This situation only occurs when extreme continuous use of your saw causes the batteries to become hot. **It does not occur under normal circumstances.** Refer to "CHARGING BATTERY PACK" for normal recharging of batteries. If the charger does not charge your battery pack under normal circumstances, return **both** the battery pack and charger to your nearest Sears repair center for electrical check.

## OPERATION

### SAW BLADES

The best of saw blades will not cut efficiently if they are not kept clean, sharp, and properly set. Using a dull blade will place a heavy load on your saw and increase the danger of kickback. Keep extra blades on hand, so that sharp blades are always available.

Gum and wood pitch hardened on blades will slow your saw down. Use gum and pitch remover, hot water, or kerosene to remove these accumulations. **Do not use gasoline.**

### BLADE GUARD SYSTEM

The lower blade guard attached to your trim saw is there for your protection and safety. It should never be altered for any reason. If it becomes damaged or begins to return slow or sluggish, do not operate your saw until the damage has been repaired or replaced. Always leave guard in operating position when using saw.

**⚠ DANGER:** When sawing through workpiece, lower blade guard does not cover blade on the underside of workpiece. Since blade is exposed on underside of workpiece, keep hands and fingers away from cutting area. Any part of your body coming in contact with moving blade will result in serious injury. See Figure 10.

Never use saw when guard is not operating correctly. Guard should be checked for correct operation before each use. If you drop your saw, check the lower blade guard and bumper for damage at all depth settings before reuse. **Note:** The guard is operating correctly when it moves freely and readily returns to the closed position. If for any reason your lower blade guard does not close freely, take it to the nearest Sears Parts and Repair Center for service before using.

LOWER BLADE GUARD  
IS IN UP POSITION  
WHEN MAKING A CUT

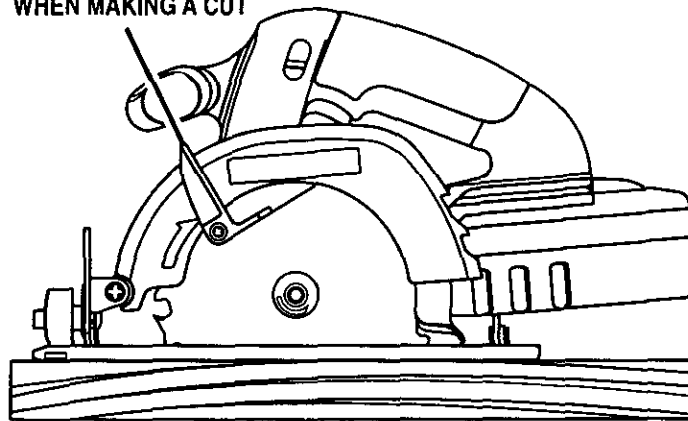

BLADE EXPOSED ON  
UNDERSIDE OF WORKPIECE

Fig. 10

# OPERATION

## KICKBACK

See Figure 11.

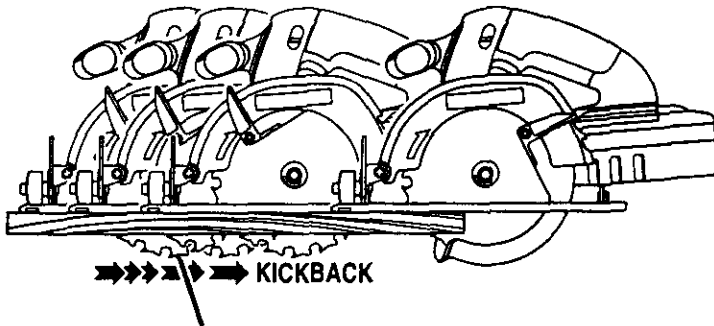

Fig. 11

The best guard against kickback is to avoid dangerous practices.

Kickback occurs when the blade stalls rapidly and the saw is driven back towards you. Blade stalling is caused by any action which pinches the blade in the wood.

**⚠ DANGER:** Release switch immediately if blade binds or saw stalls. Kickback could cause you to lose control of your saw. Loss of control can lead to serious injury.

## KICKBACK IS CAUSED BY:

- Incorrect blade depth setting. See Figure 11.
- Sawing into knots or nails in workpiece.
- Twisting blade while making a cut.
- Making a cut with a dull, gummed up, or improperly set blade.
- Incorrectly supporting workpiece. See Figure 12.
- Forcing a cut.
- Cutting warped or wet lumber.
- Tool misuse or incorrect operating procedures.

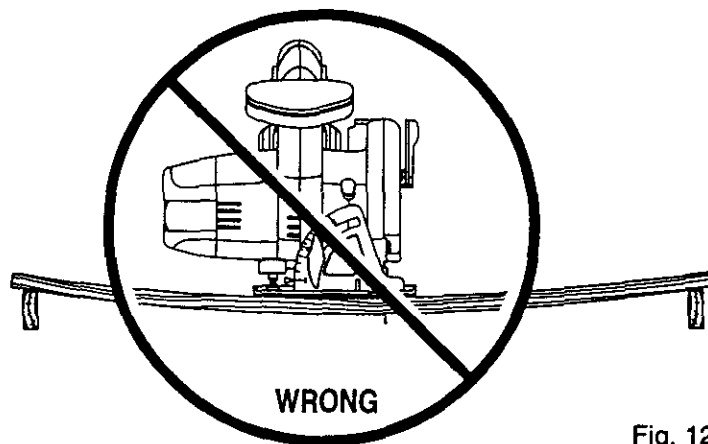

Fig. 12

## TO LESSEN THE CHANCE OF KICKBACK:

- Always keep the correct blade depth setting – the correct blade depth setting for all cuts should not exceed 1/4 in. below the material to be cut. See Figure 13. One blade tooth below the material to be cut works best for most efficient cutting action.

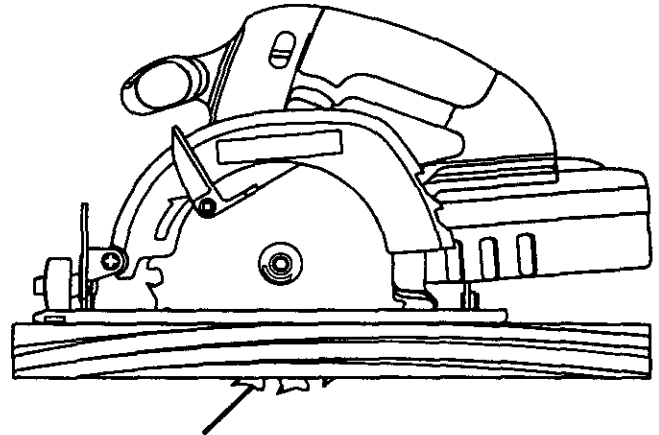

Fig. 13

- Inspect the workpiece for knots or nails before beginning a cut. Never saw into a knot or nail.
- Make straight cuts. Always use a straight edge guide when rip cutting. This helps prevent twisting the blade in the cut.
- Always use clean, sharp and properly set blades. Never make cuts with dull blades.
- To avoid pinching the blade, support the workpiece properly before beginning a cut. The right and wrong ways to support large pieces of work are shown in figures 12 and 14.

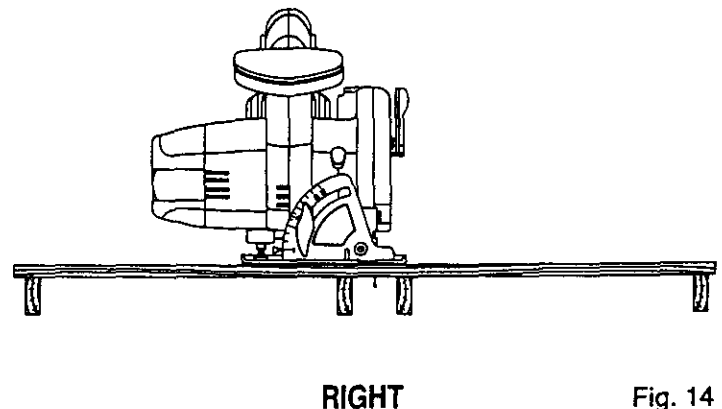

Fig. 14

# OPERATION

- When making a cut use steady, even pressure. Never force cuts.
- Do not cut warped or wet lumber.
- Always hold your saw firmly with both hands and keep your body in a balanced position so as to resist the forces of kickback should it occur.

When using your saw, always stay alert and exercise control. Do not remove your saw from workpiece while the blade is moving.

## DEPTH OF CUT ADJUSTMENT

Always keep correct blade depth setting. The correct blade depth setting for all cuts should not exceed 1/4 inch below the material to be cut. More blade depth will increase the chance of kickback and cause the cut to be rough. One blade tooth below the material to be cut works best for most efficient cutting action.

## TO ADJUST BLADE DEPTH

- Remove battery pack from saw.

**⚠ WARNING:** Failure to remove battery pack from saw could result in accidental starting causing possible serious personal injury.

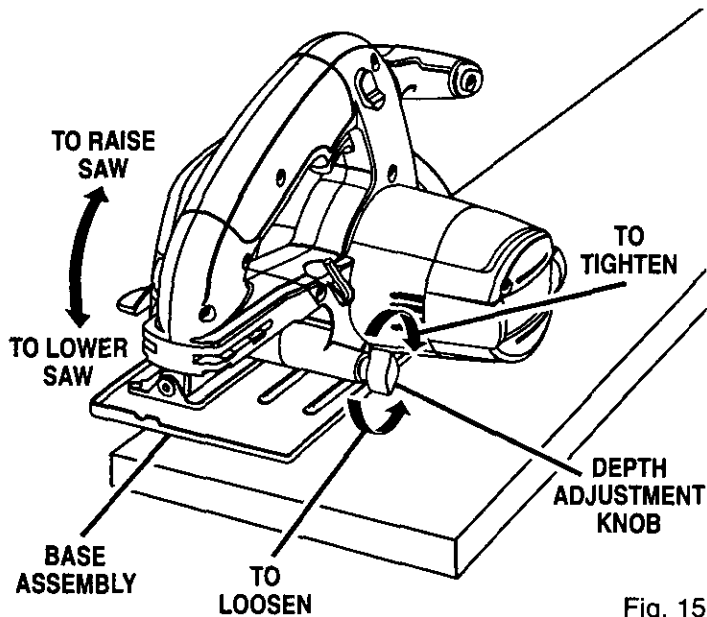

Fig. 15

- Loosen depth adjustment knob. See Figure 15.
- Hold base flat against the workpiece and raise or lower saw until the required depth is reached.
- Tighten depth adjustment knob securely.

## STARTING A CUT

Know the right way to use your saw.  
See Figure 16.

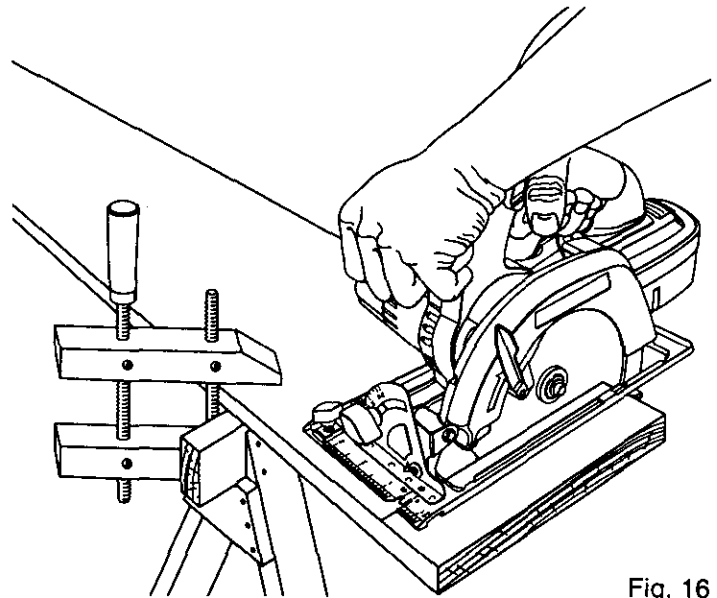
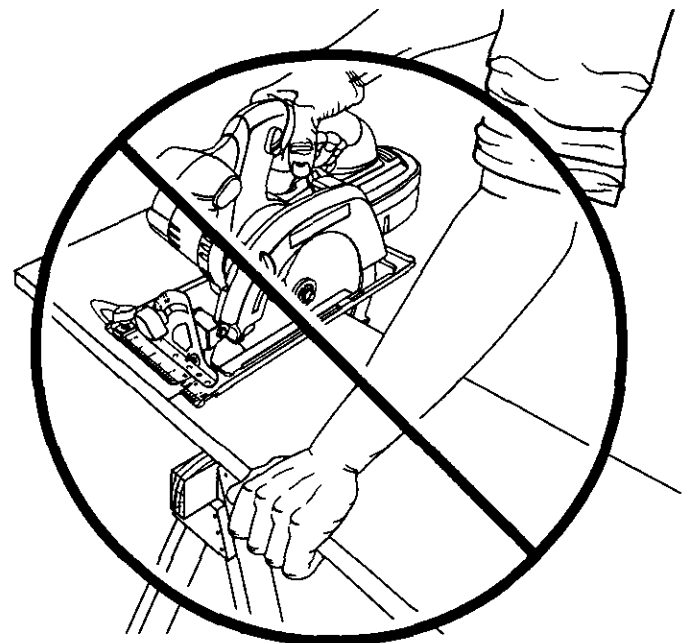

Fig. 16

Never use your saw as shown in figure 17.



WRONG

Fig. 17

Never place your hand on the workpiece behind your saw while making a cut.

**⚠ WARNING:** To make sawing easier and safer, always maintain proper control of your saw. Loss of control of your saw could cause an accident resulting in possible serious injury.

## OPERATION

### TO HELP MAINTAIN CONTROL:

- Always support your workpiece near the cut.
- Support your workpiece so the cut will be on your left.
- Clamp your workpiece so it will not move during the cut.

Place your workpiece with its good side down.

**Note:** The good side is the side on which appearance is important.

Before beginning a cut, draw a guideline along the desired line of cut. Then place front edge of base on that part of your workpiece that is solidly supported. *See Figure 16.*

**Never place your saw on that part of the workpiece that will fall off when the cut is made. *See Figure 18.***

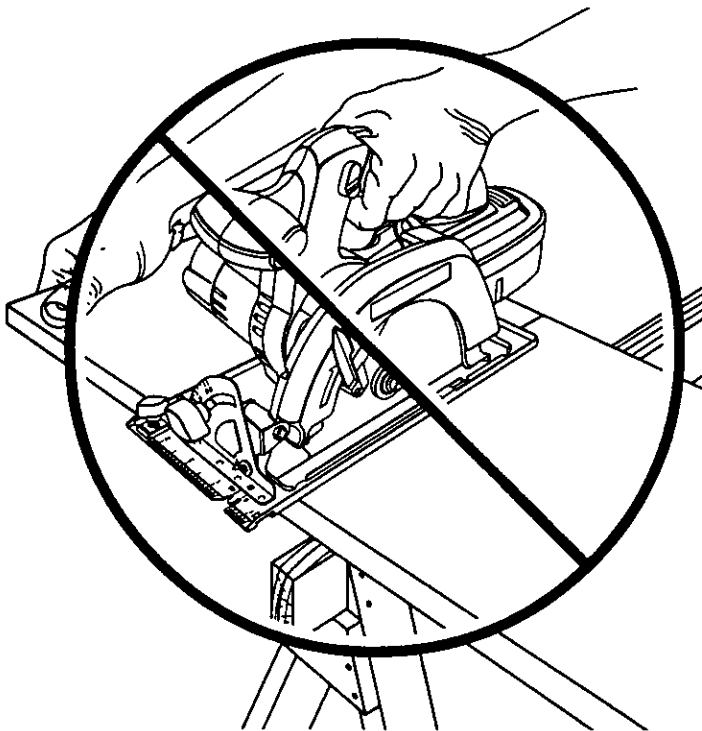

WRONG

Fig. 18

Hold your saw firmly with both hands.  
*See Figure 19.*

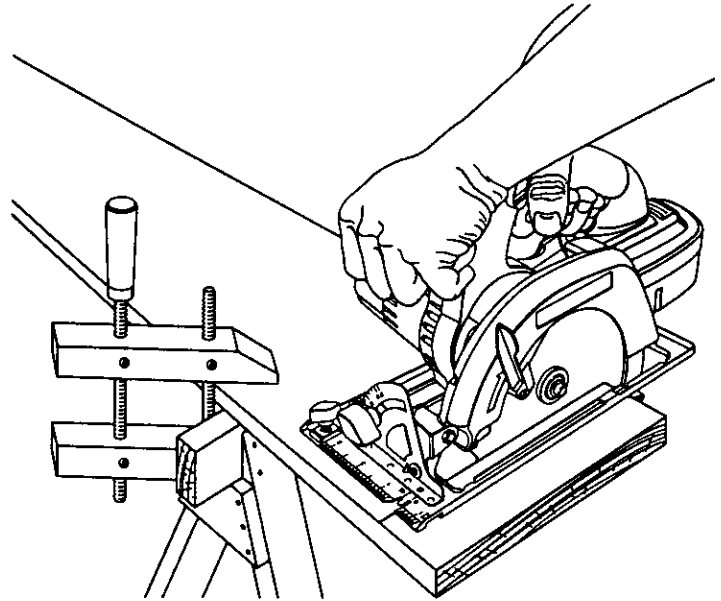

RIGHT

Fig. 19

Depress the lock-off button and squeeze the switch trigger to start your saw. **Always** let the blade reach full speed, then guide your saw into the workpiece.

**⚠ WARNING:** The blade coming in contact with the workpiece before it reaches full speed could cause your saw to "kickback" towards you resulting in serious injury.

When making a cut use steady, even pressure. Forcing causes rough cuts, could shorten the life of your saw and could cause "kickback."

### REMEMBER:

When sawing through work, the lower blade guard does not cover the blade, exposing it on the underside of work. Keep your hands and fingers away from cutting area. Any part of your body coming in contact with the moving blade will result in serious injury.

After you complete your cut release the trigger and allow the blade to come to a complete stop. **Do not remove your saw from workpiece while the blade is moving.**

**⚠ CAUTION:** When lifting your saw from the workpiece, the blade is exposed on the underside of your saw until the lower blade guard closes. Make sure lower blade guard is closed before setting your saw down on work surface.



# OPERATION

## TO CROSS CUT OR RIP CUT

When making a cross cut or rip cut, align your line of cut with the outer blade guide notch on the saw base as shown in figure 20.

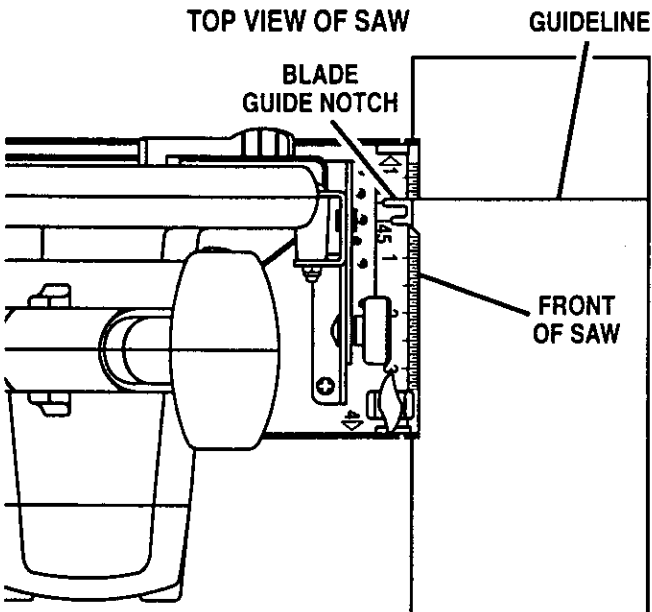

ALIGN OUTER BLADE GUIDE NOTCH ON SAW BASE WITH LINE OF CUT AS SHOWN WHEN MAKING CROSS CUTS OR RIP CUTS

Fig. 20

Since blade thicknesses vary, always make a trial cut in scrap material along a guideline to determine how much, if any, the guideline must be offset to produce an accurate cut.

**Note:** The distance from the line of cut to the guideline is the amount you should offset the guideline.

## WIDTH OF CUT SCALE

See Figure 21.

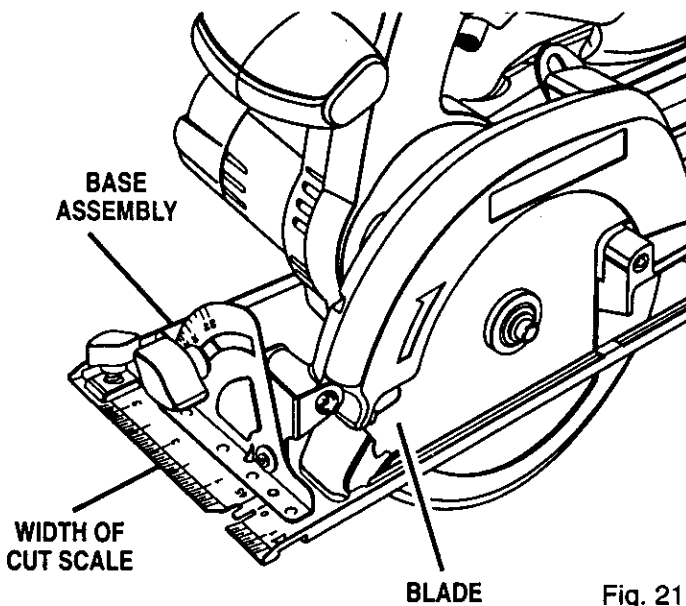

Fig. 21

A width of cut scale has been provided on the base of your saw. When making straight cross cuts or rip cuts, the scale can be used to measure up to four inches to the right side of the blade. It can be used to measure up to one inch to the left side of the blade.

## RIP GUIDE (EDGE GUIDE)

Use the rip guide provided with your saw when making wide rip cuts. A five inch scale has been provided on the rip guide. When using the width of cut scale on the base in combination with the rip guide, cuts can be made up to 6 in. to the left of the rip guide or 8-7/8 in. to the right of the rip guide.

The rip guide helps prevent the blade from twisting in a cut. The blade twisting in a cut can cause kickback.

## TO ASSEMBLE RIP GUIDE

- Remove battery pack from saw.

**⚠ WARNING:** Failure to remove battery pack from saw could result in accidental starting causing possible serious personal injury.

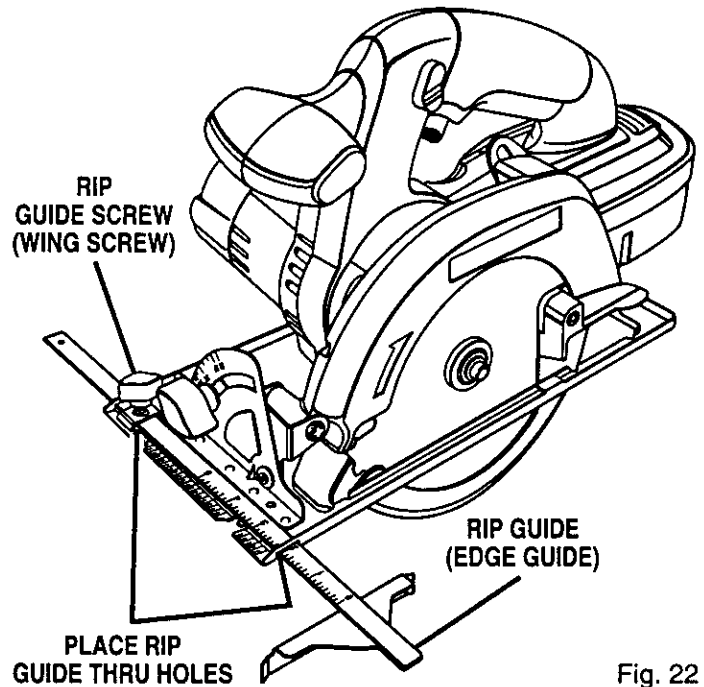

Fig. 22

- Place rip guide through holes in saw base as shown in figure 22.
- Adjust rip guide to the width needed.
- Tighten rip guide screw (wing screw) securely.

When using a rip guide, position the face of the rip guide firmly against the edge of workpiece. This makes for a true cut without pinching the blade. The guiding edge of workpiece must be straight for your cut to be straight. Use caution to prevent the blade from binding in the cut.

# OPERATION

## ALTERNATIVE RIP METHOD

See Figure 23.

Using C-clamps, firmly clamp a straight edge to the workpiece and guide the saw along the straight edge to achieve a straight rip cut. Do not bind the blade in the cut.

### ALTERNATIVE METHOD FOR RIP CUTTING

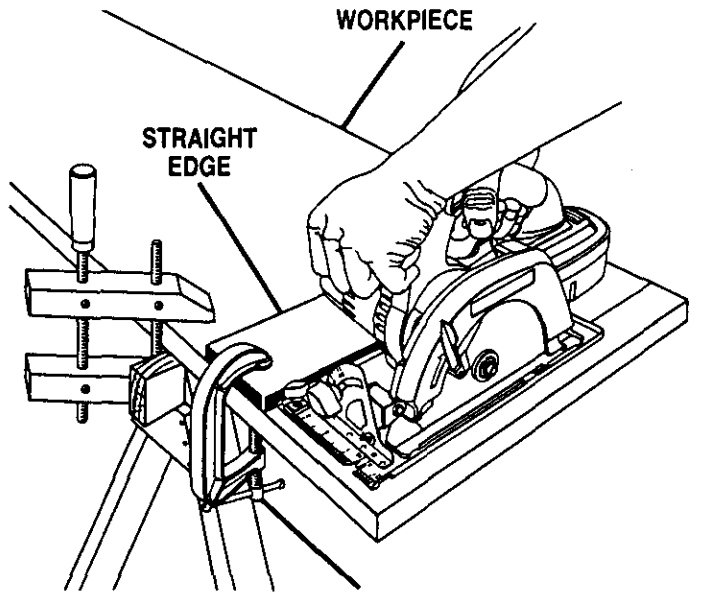

NOTE: C-CLAMP BOTH ENDS OF STRAIGHT EDGE BEFORE MAKING CUT Fig. 23

## TO BEVEL CUT

The angle of cut of your saw may be adjusted to any desired setting between zero and 50°. Note: When making cuts at 50°, blade should be set at full depth of cut.

When making 45° bevel cuts, there is a notch in the saw base to help you line up the blade with the line of cut. See Figure 24.

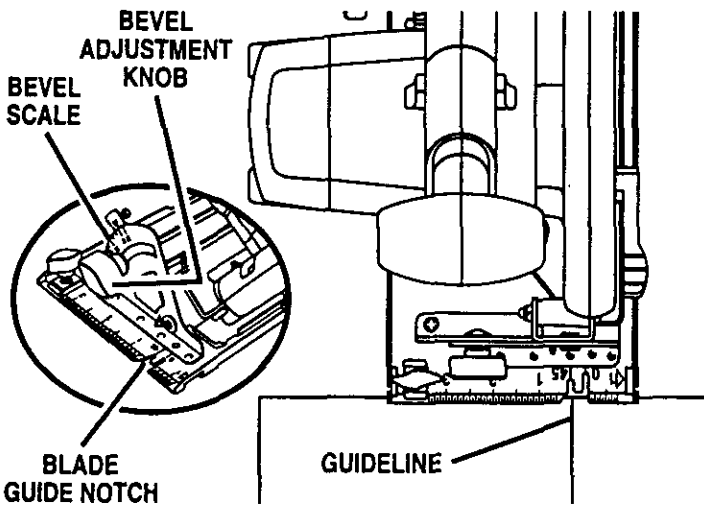

ALIGN INNER BLADE GUIDE NOTCH ON SAW BASE WITH LINE OF CUT AS SHOWN WHEN MAKING 45° BEVEL CUTS

Fig. 24

Align your line of cut with the inner blade guide notch on the saw base when making 45° bevel cuts.

Since blade thicknesses vary and different angles require different settings, always make a trial cut in scrap material along a guideline to determine how much you should offset the guideline on the board to be cut.

When making a bevel cut, hold your saw firmly with both hands as shown in figure 25.

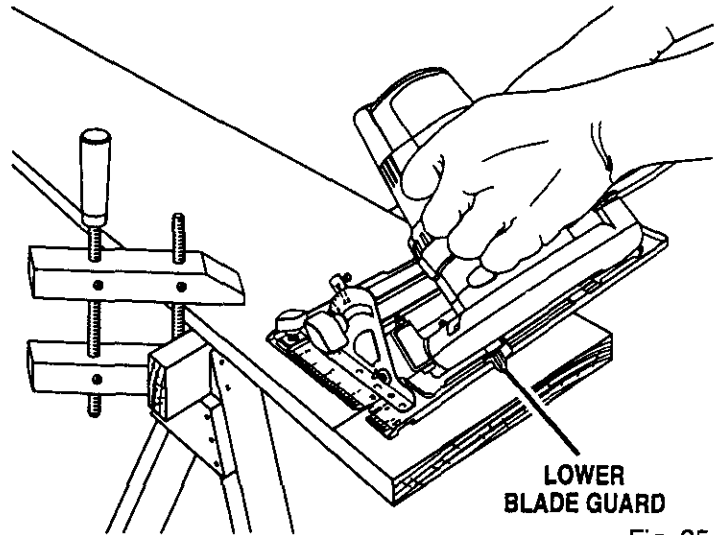

Fig. 25

Rest the front edge of the base on the workpiece. Depress the lock-off button and squeeze the switch trigger to start your saw. Always let the blade reach full speed, then guide your saw into the workpiece.

**WARNING:** The blade coming in contact with the workpiece before it reaches full speed could cause saw to "kickback" toward you resulting in serious injury.

After you complete your cut release the trigger and allow the blade to come to a complete stop. After the blade has stopped, lift your saw from the workpiece.

## TO ADJUST BEVEL SETTING

■ Remove battery pack from saw.

**WARNING:** Failure to remove battery pack from saw could result in accidental starting causing possible serious personal injury.

■ Loosen bevel adjustment knob. See Figure 24.

■ Raise motor housing end of saw until you reach desired angle setting on bevel scale. See Figure 24.

■ Tighten bevel adjustment knob securely.

**WARNING:** Attempting bevel cut without knob securely tightened can result in serious injury.

# OPERATION

## POSITIVE 0° BEVEL STOP

See Figure 26.

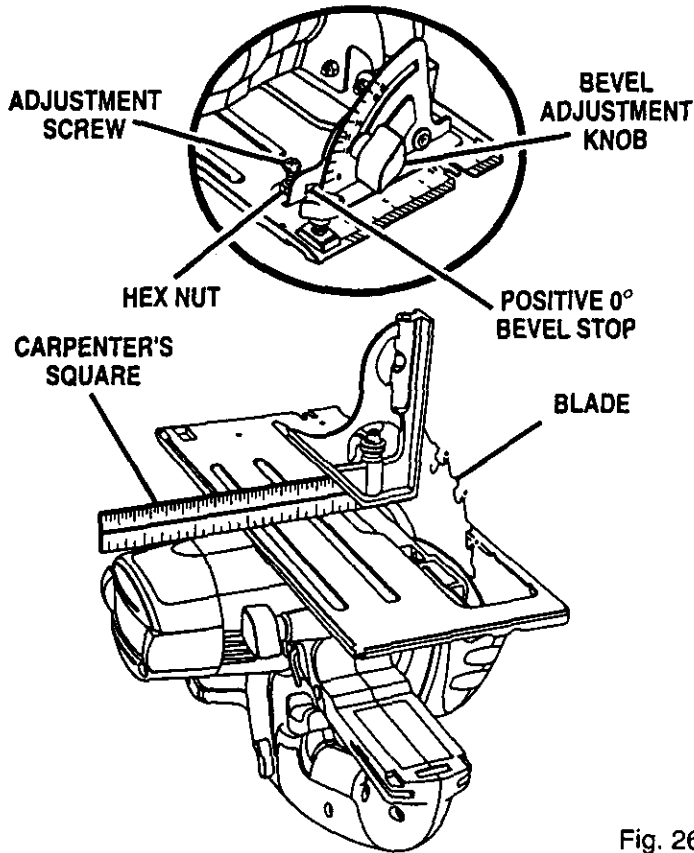

Fig. 26

Your saw has a positive 0° bevel stop, that has been factory adjusted to assure 0° angle of your saw blade when making 90° cuts. However, misalignment can occur during shipping.

### TO CHECK

- Remove battery pack from saw.

**⚠ WARNING:** Failure to remove battery pack from saw could result in accidental starting causing possible serious personal injury.

- Place your saw in an upside down position on workbench. See Figure 26.
- Using a carpenter's square, check squareness of saw blade to the base of your saw.

### TO ADJUST

- Remove battery pack from saw.

**⚠ WARNING:** Failure to remove battery pack from saw could result in accidental starting causing possible serious personal injury.

- Loosen bevel adjustment knob.
- Loosen hex nut securing adjustment screw.

- Turn screw and adjust base until square with saw blade.
- Tighten hex nut and bevel adjustment knob securely.

**⚠ WARNING:** Attempting to make cuts without bevel adjustment knob securely tightened can result in serious injury.

### TO POCKET CUT

See Figure 27.

**⚠ WARNING:** Always adjust bevel setting to zero before making a pocket cut. Attempting a pocket cut at any other setting can result in loss of control of your saw possibly causing serious injury.

Adjust the bevel setting to zero, set blade to correct blade depth setting, and swing the lower blade guard up using the lower blade guard handle.

**Always raise the lower blade guard with the handle to avoid serious injury.**

While holding lower blade guard by the handle, firmly rest the front of the base flat against the workpiece with the rear of the handle raised so the blade does not touch the workpiece. See Figure 27.

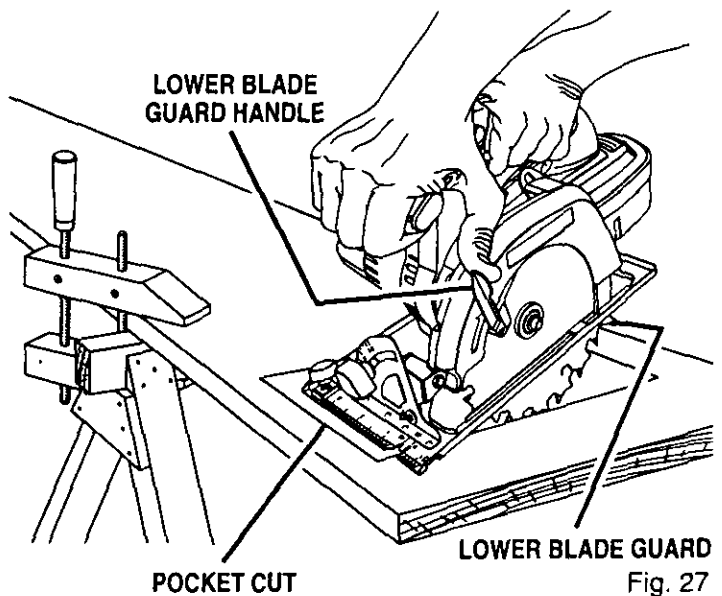

Fig. 27

Depress the lock-off button and squeeze the switch trigger to start your saw. **Always let the blade reach full speed then slowly lower blade into the workpiece until base is flat against workpiece.**

After you complete your cut release the trigger and allow the blade to come to a complete stop. After the blade has stopped, remove it from the workpiece. Corners may then be cleared out with a hand saw or sabre saw.

**⚠ WARNING:** Never tie the lower blade guard in a raised position. Leaving the blade exposed could lead to serious injury.

## MAINTENANCE

**⚠ WARNING:** When servicing, use only identical Craftsman replacement parts. Use of any other part may create a hazard or cause product damage.

Avoid using solvents when cleaning plastic parts. Most plastics are susceptible to damage from various types of commercial solvents and may be damaged by their use. Use clean cloths to remove dirt, dust, oil, grease, etc.

**⚠ WARNING:** Do not at any time let brake fluids, gasoline, petroleum-based products, penetrating oils, etc. come in contact with plastic parts. They contain chemicals that can damage, weaken or destroy plastic.

Do not abuse power tools. Abusive practices can damage tool as well as workpiece.

Only the parts shown on parts list, page 23, are intended to be repaired or replaced by the customer. All other parts should be replaced at a Sears Service Center.

**⚠ WARNING:** Do not attempt to modify this tool or create accessories not recommended for use with this tool. Any such alteration or modification is misuse and could result in a hazardous condition leading to possible serious personal injury.

---

## BATTERIES

Your saw's battery pack is equipped with 20 nickel-cadmium rechargeable batteries. Length of service from each charging will depend on the type of work you are doing.

The batteries in this tool have been designed to provide maximum trouble free life. However, like all batteries, they will eventually wear out. **Do not** disassemble battery pack and attempt to replace the batteries. Handling of these batteries, especially when wearing rings and jewelry, could result in a serious burn.

To obtain the longest possible battery life, we suggest the following:

- Store and charge your batteries in a cool area. Temperatures above normal room temperature will shorten battery life.
- Never store batteries in a discharged condition. Recharge them immediately after they are discharged.
- All batteries gradually lose their charge. The higher the temperature the quicker they lose their charge. If you store your tool for long periods of time without using it, recharge the batteries every month or two. This practice will prolong battery life.



To preserve natural resources, please recycle or dispose of batteries properly.

This product contains nickel-cadmium battery. Local, state, or federal laws may prohibit disposal of nickel-cadmium batteries in ordinary trash.

Consult your local waste authority for information regarding available recycling and/or disposal options.

---

## BATTERY PACK REMOVAL AND PREPARATION FOR RECYCLING

**⚠ WARNING:** Upon removal, cover the battery pack's terminals with heavy duty adhesive tape. Do not attempt to destroy or disassemble battery pack or remove any of its components. Nickel-cadmium batteries must be recycled or disposed of properly. Also, never touch both terminals with metal objects and/or body parts as short circuit may result. Keep away from children. Failure to comply with these warnings could result in fire and/or serious injury.

## ACCESSORIES

The following recommended accessories are currently available at Sears Retail Stores.

- 6-1/2 in. (165 mm) Thin Kerf Blade

 **WARNING:** The use of attachments or accessories not listed might be hazardous.

### WARRANTY

#### **FULL ONE YEAR WARRANTY ON CRAFTSMAN PROFESSIONAL CORDLESS TRIM SAW**

If this **CRAFTSMAN** Professional Cordless Trim Saw fails due to a defect in material or workmanship within one year from the date of purchase, Sears will repair it, free of charge.

**WARRANTY SERVICE IS AVAILABLE BY SIMPLY RETURNING THE TOOL TO THE NEAREST SEARS STORE OR SEARS SERVICE CENTER IN THE UNITED STATES.**

This warranty gives you specific legal rights, and you may also have other rights which vary from state to state.

**Sears, Roebuck and Co., Dept. 817WA, Hoffman Estates, IL 60179**

## SAVE THESE INSTRUCTIONS

CRAFTSMAN 24 VOLTS, PROFESSIONAL CORDLESS TRIM SAW – MODEL NUMBER 315.271030

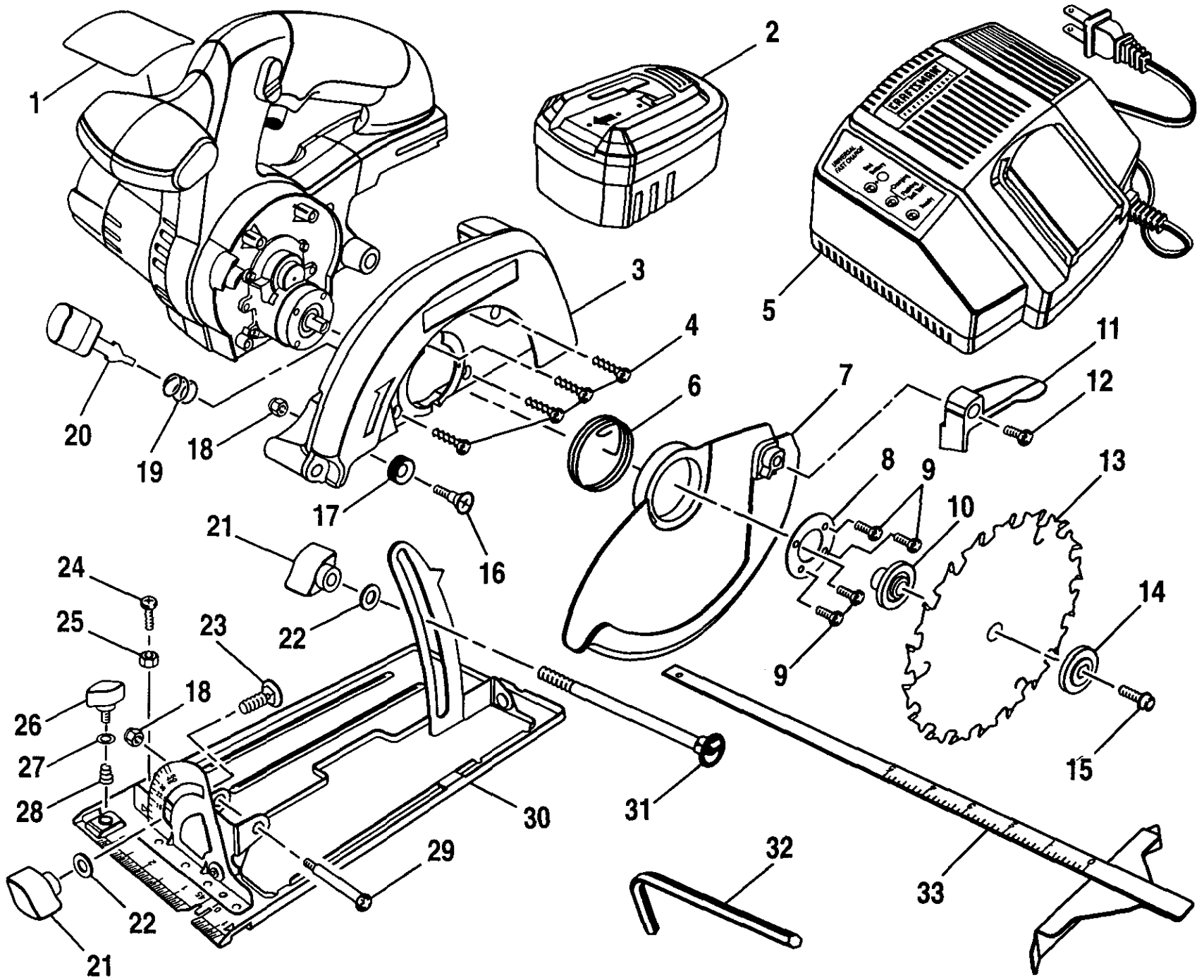

**CRAFTSMAN 24 VOLTS, PROFESSIONAL CORDLESS TRIM SAW – MODEL NUMBER 315.271030**

The model number will be found on a plate attached to the motor housing. Always mention the model number in all correspondence regarding your **CORDLESS TRIM SAW** or when ordering repair parts.

**SEE BACK PAGE FOR PARTS ORDERING INSTRUCTIONS**

**PARTS LIST**

| Key No. | Part Number        | Description                     | Quan. | Key No. | Part Number | Description                       | Quan. |
|---------|--------------------|---------------------------------|-------|---------|-------------|-----------------------------------|-------|
| 1       | 982484-001         | Data Plate .....                | 1     | 18      | 975544-000  | Lock Nut .....                    | 2     |
| 2       | **Item No. 9-11035 | Battery Pack (981405-001) ..... | 1     | 19      | 982164-001  | Spring .....                      | 1     |
| 3       | 982158-001         | Upper Blade Guard .....         | 1     | 20      | 982165-001  | Spindle Lock.....                 | 1     |
| 4       | 982159-001         | Upper Blade Guard Screw .....   | 4     | 21      | 982166-001  | Knob .....                        | 2     |
| 5       | **Item No. 9-11040 | Charger (981399-001) .....      | 1     | 22      | 982167-001  | Washer .....                      | 2     |
| 6       | 982160-001         | Spring .....                    | 1     | 23      | 982168-001  | Carriage Bolt (M6 x 12 mm).....   | 1     |
| 7       | 982161-001         | Lower Blade Guard .....         | 1     | 24      | 975558-000  | Screw .....                       | 1     |
| 8       | 982162-001         | Guard Retainer .....            | 1     | 25      | 975559-000  | Hex Nut .....                     | 1     |
| 9       | 982163-001         | Guard Retainer Screw .....      | 4     | 26      | 982169-001  | Wing Screw .....                  | 1     |
| 10      | 975534-000         | Inner Blade Washer .....        | 1     | 27      | 982170-001  | Washer .....                      | 1     |
| 11      | 982427-001         | Lower Blade Guard Handle .....  | 1     | 28      | 975552-000  | Spring .....                      | 1     |
| 12      | 982428-001         | Screw .....                     | 1     | 29      | 982171-001  | Base Screw .....                  | 1     |
| 13      | *                  | Saw Blade .....                 | 1     | 30      | 982485-001  | Base Assembly .....               | 1     |
| 14      | 975533-000         | Outer Blade Washer .....        | 1     | 31      | 982173-001  | Carriage Bolt (M6 x 100 mm).....  | 1     |
| 15      | 975532-000         | Blade Screw .....               | 1     | 32      | 975553-000  | Blade Wrench (5 mm Hex Key) ..... | 1     |
| 16      | 982426-001         | Bumper Screw.....               | 1     | 33      | 975554-000  | Rip Guide .....                   | 1     |
| 17      | 982425-001         | Bumper.....                     | 1     | 34      | 982175-002  | Carrying Case – Not Shown         |       |
|         |                    |                                 |       |         | 972000-829  | Owner's Manual                    |       |

\* Available At Your Nearest Sears Catalog Order Or Retail Store

\*\* Can Be Purchased Thru RSOS (Retail Special Order System)

# Get it fixed, at your home or ours!

For repair of major brand appliances **in your own home...**  
no matter who made it, no matter who sold it!

**1-800-4-MY-HOME<sup>SM</sup>** Anytime, day or night  
(1-800-469-4663)

[www.sears.com](http://www.sears.com)

To bring in products such as vacuums, lawn equipment and electronics  
for repair, call for the location of your nearest **Sears Parts & Repair Center.**

**1-800-488-1222** Anytime, day or night

[www.sears.com](http://www.sears.com)

For the replacement parts, accessories and owner's manuals  
that you need to do-it-yourself, call **Sears PartsDirect<sup>SM</sup>!**

**1-800-366-PART** 6 a.m. – 11 p.m. CST,  
(1-800-366-7278) 7 days a week

[www.sears.com/partsdirect](http://www.sears.com/partsdirect)

To purchase or inquire about a Sears Service Agreement:

**1-800-827-6655**

7 a.m. – 5 p.m. CST, Mon. – Sat.

Para pedir servicio de reparación a domicilio,  
y para ordenar piezas con entrega a domicilio:

**1-888-SU-HOGAR<sup>SM</sup>**  
(1-888-784-6427)

Au Canada pour service en français:

**1-877-LE-FOYER<sup>SM</sup>**  
(1-877-533-6937)

