

Owner's Manual
Manual del Propietario

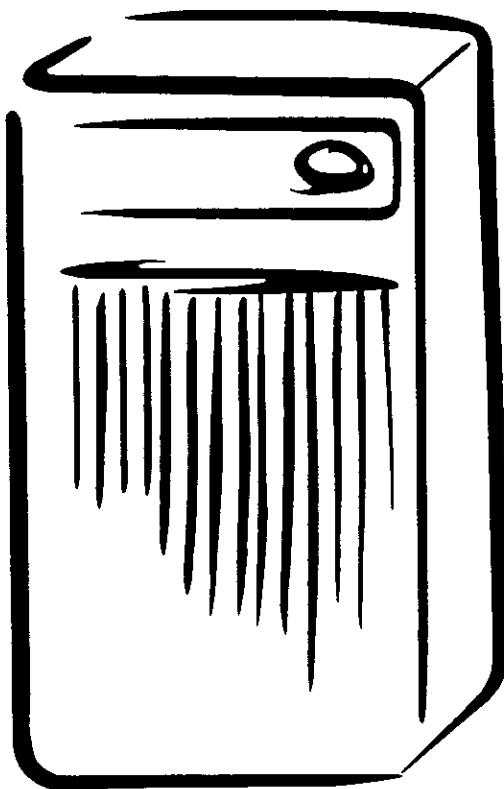

DEHUMIDIFIER
DESHUMIDIFICADOR

Model, Modelo 580.52650



ENGLISH

ESPAÑOL

Sears, Roebuck and Co., Hoffman Estates, IL 60179 U.S.A.
www.sears.com

TABLE OF CONTENTS

TABLE OF CONTENTS	2	AUTOMATIC SHUT OFF	8
WARRANTY	2	REMOVING AND EMPTYING THE WATER BUCKET	8
SAFETY	3	MAINTENANCE	9
Important Safety Instructions	3	Grille and case	9
ELECTRICAL REQUIREMENTS	4	Air filter	9
OPERATION	5	Cleaning inside the unit	9
Features	5	General cleaning	9
Control Panel	6	Water bucket cleaning	9
INSTALLING YOUR DEHUMIDIFIER	7	TROUBLESHOOTING	10
Defrost control	7	REPAIR PARTS	11
CHOOSING THE PROPER LOCATION	7	ESPAÑOL	14
		SERVICE NUMBERS	Back Cover

WARRANTY

FULL ONE YEAR WARRANTY ON DEHUMIDIFIER

For one year from the date of purchase, if the Dehumidifier is operated and maintained according to the owner's instructions furnished with the product, Sears will repair the Dehumidifier free of charge, if defective in materials or workmanship.

FULL FIVE YEAR WARRANTY ON SEALED REFRIGERATION SYSTEM

For five years from the date of purchase, when this Dehumidifier is operated and maintained according to owner's instructions furnished with the product, Sears will repair the sealed refrigeration system (consisting of refrigerant, connecting tubing, and compressor motor) free of charge, if defective in material or workmanship.

WARRANTY SERVICE IS AVAILABLE BY RETURNING UNIT TO THE NEAREST SEARS SERVICE CENTER IN THE UNITED STATES.

This warranty applies only while this Dehumidifier is used in the United States. This warranty gives you specific legal rights, and you may also have other rights which vary from state to state.

Sears, Roebuck and Co., D/817WA, Hoffman Estates, IL 60179 U.S.A.

SAFETY

IMPORTANT SAFETY INSTRUCTIONS

The safety instructions below will tell you how to use your dehumidifier to avoid harm to yourself or damage to your dehumidifier.

⚠ WARNING FOR YOUR SAFETY

Do not store or use gasoline or other flammable vapors and liquids in the vicinity of this or any other appliance. Read product labels for flammability and other warnings.

⚠ WARNING PREVENT ACCIDENTS

To reduce the risk of fire, electrical shock, or injury to persons when using your dehumidifier, follow basic precautions, including the following:

- Be sure the electrical service is adequate for the model you have chosen.

⚠ WARNING ELECTRICAL INFORMATION

The complete electrical rating of your new dehumidifier is stated on the serial plate. Refer to the rating when checking the electrical requirements.

- Be sure the dehumidifier is properly grounded. To minimize shock and fire hazards, proper grounding is important. The power cord is equipped with a three-prong grounding plug for protection against shock hazards.
- Your dehumidifier must be used in a properly grounded wall receptacle. If the wall receptacle you intend to use is not adequately grounded or protected by a time delay fuse or circuit breaker, have a qualified electrician install the proper receptacle.
- **Do not use an extension cord or an adapter plug.**

⚠ WARNING Avoid fire hazard or electric shock. Do not use an extension cord or an adapter plug. Do not remove any prong from the power cord.

Grounding type wall receptacle

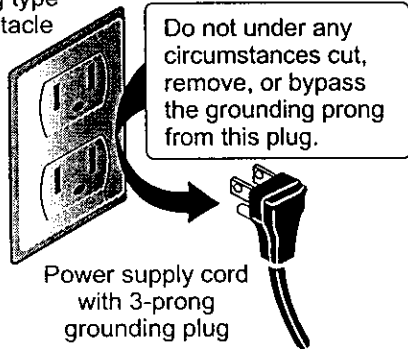

Power supply cord with 3-prong grounding plug

ENGLISH

ELECTRICAL REQUIREMENTS

OBSERVE ALL LOCAL CODES AND ORDINANCES.

DO NOT, UNDER ANY CIRCUMSTANCES, REMOVE THE POWER SUPPLY CORD GROUND PRONG.

ELECTRICAL GROUND IS REQUIRED ON THIS APPLIANCE.

A 115-volt 60 Hz, AC only, 15A fused and properly grounded electrical supply is required. A time delay fuse or time delay circuit breaker is recommended. Use a dedicated circuit, serving only this appliance.

DO NOT USE AN EXTENSION CORD.

RECOMMENDED GROUNDING METHOD

For your personal safety, this appliance must be grounded. This appliance has a power supply cord with a 3-prong grounding plug. To minimize possible shock hazard, the cord must be plugged into a mating grounding type wall receptacle and grounded in accordance with the National Electrical Code (ANSI/NFPA 70) latest edition and all local codes and ordinances. If a mating wall receptacle is not available, it is the personal responsibility and obligation of the customer to have a properly grounded 3-prong wall receptacle installed by a qualified electrician.

⚠ WARNING	
	
Electrical Shock Hazard	
Plug into a grounded 3 prong outlet.	
Do not remove ground prong.	
Do not use an adapter.	
Do not use an extension cord.	
Failure to follow these instructions can result in death, fire, or electrical shock.	

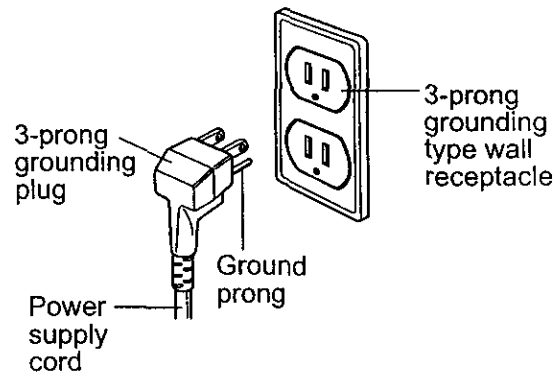

OPERATION

FEATURES

⚠ WARNING

To reduce the risk of fire, electric shock, or injury to persons, read the important SAFETY instructions section before operating this appliance.

1. CONTROL PANEL
2. GRILLE, FRONT
3. POWER CORD
4. CABINET
5. AIR FILTER
6. WATER BUCKET

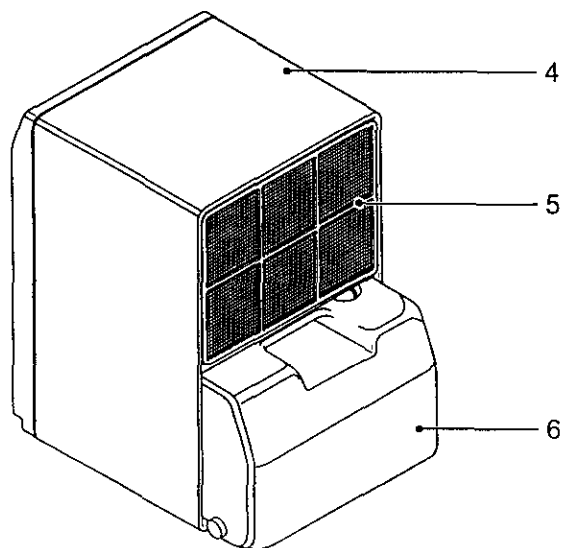
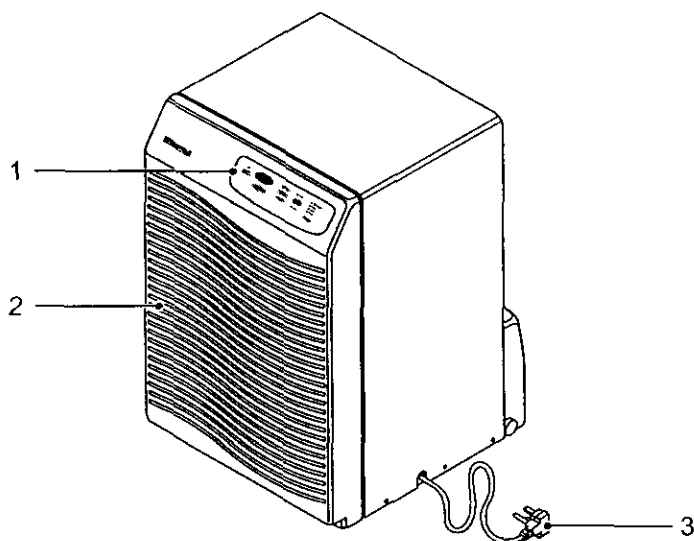

ENGLISH

OPERATION

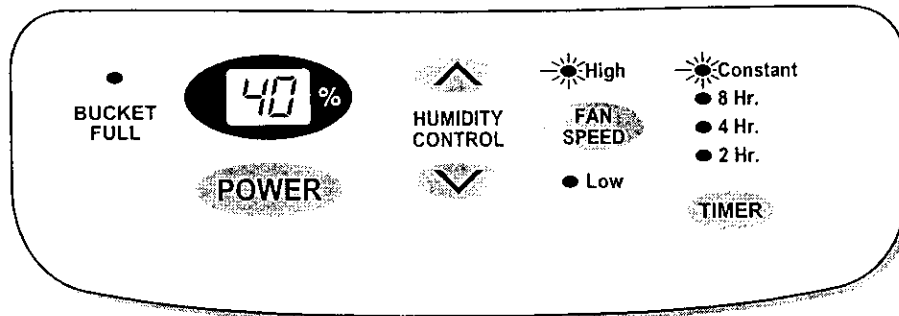

CONTROL PANEL

Your dehumidifier control panel contains a Bucket Full indicator, a Humidity indicator, a Power Control, Humidity Control, Fan Speed Control and Timer Control.

Bucket Full indicator --- This light glows when the water bucket is full and needs to be emptied.

Power --- Operation starts when this button is pressed and stops when the button is pressed again.

Humidity Control --- This controls the humidity in the room.

- : To raise the humidity setting
- : To lower the humidity setting
- The humidity can be set within a range of 30% RH~70% RH by 5% increments.

Fan Speed --- This controls the speed of the airflow.

- High: Fan speed is set to high.
- Low: Fan speed is set to low.
- When Fan Speed button is pressed, the fan speed mode is changed.

Timer Control --- Press the Timer button to set the amount of time you want the unit to run.

- The Timer can be set for: Constant, 8 hour, 4 hour or 2 hour.
- When Timer button is pressed, the Timer indicator lights shift as follows:
Constant → 2 hr. → 4 hr. → 8 hr. → Constant

TO OPERATE THE DEHUMIDIFIER:

1. Plug the power cord into an electrical outlet. Press the power button.
2. Set the Humidity Control anywhere between 30% RH and 70% RH for normal operation.
If you need more drier air, press the Humidity Control button.
If you need less moisture air, press the Humidity Control button.
3. Press the Power button to stop the unit manually.
4. Press the Timer button to set the amount of time you want the unit to run.
At the end of that time, the unit will shut off.
The Timer can be set for : Constant, 8 hours, 4 hours or 2 hours.
5. If you want to control the speed of airflow, press Fan Speed button. Each time that the Fan Speed button is pressed, the fan speed mode is shifted: High → Low → High

Note: Be careful not to lose the water bucket.

This dehumidifier doesn't run if the water bucket is not installed properly.

INSTALLING YOUR DEHUMIDIFIER

- Install the dehumidifier on a level floor strong enough to support the unit with a full bucket of water.
- For best performance, allow at least 12-18 inches of air space on all sides of the unit for good air circulation.
- Keep all outside doors, windows, and other openings closed when operating the dehumidifier. Humid outdoor air will add to the unit's work load.

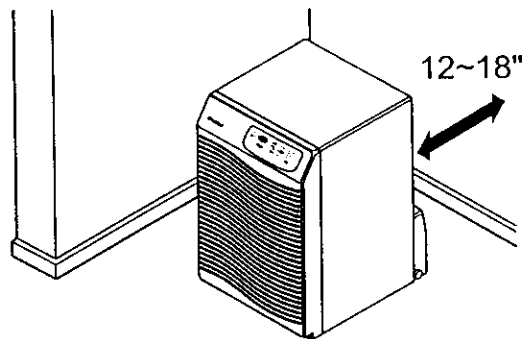

- Install your dehumidifier in an area where the temperature will not fall below 65°F (18°C). At temperatures below this, the coils can become covered with frost.

NOTE : If frost occurs, the unit will cycle on and off. This is normal. Unplug the unit (or turn the unit off) until the frost melts and the room temperature rises.

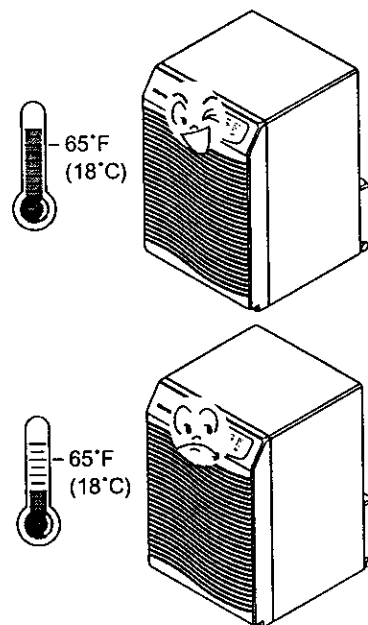

DEFROST CONTROL

When the defrost control senses frost build-up on the evaporator coil, it will automatically shut off the compressor. The fan will continue to run to draw air across the coil and melt the frost. When the coil is defrosted, the compressor will automatically restart and dehumidifying resume.

CHOOSING THE PROPER LOCATION

- Use the dehumidifier in a basement to help prevent moisture damage.
- Use the dehumidifier in cooking, laundry, bathing, and dishwashing areas that have excessive moisture.
- Use the dehumidifier to prevent moisture damage anywhere books or valuables are stored.

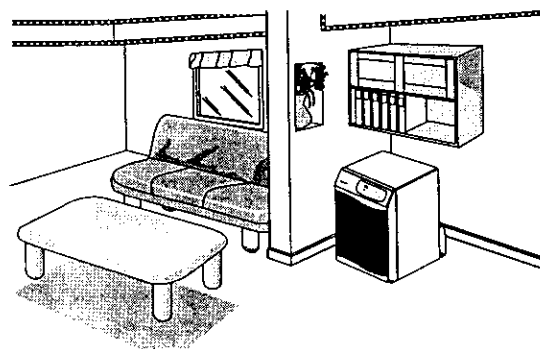

AUTOMATIC SHUT OFF

When the bucket is full, or when the bucket is not in the proper position, the Bucket Full light turns on and the unit automatically shuts off.

Also, when bucket is out of position, the unit will beep 3times.

The bucket must be replaced in the proper position for the dehumidifier to work. The light will be on and the dehumidifier will not run if the bucket is not in the proper position.

REMOVING AND EMPTYING THE WATER BUCKET

The water bucket can be emptied in one of three ways:

Empty the bucket manually.

When the bucket is full, remove and empty it into a large sink or tub. When finished, replace it properly.

NOTE: To replace the bucket properly, make sure the slots on the back of bucket are positioned correctly.

Place the dehumidifier directly over drain.

The bucket has a threaded hose connection which can be left open. Drill a 1/4" (6.4mm) to 1/2"(13mm) hole in the center of the hose connection. Once opened, the hose connection will continually drain water from the bucket.

Attach a garden hose to the threaded bucket drain hose connection to carry water to the drain. (HAND TIGHTEN ONLY)

When being attached to the bucket drain hose connection, be sure the hose doesn't kink or bend. It should lie flat from the dehumidifier to the drain.

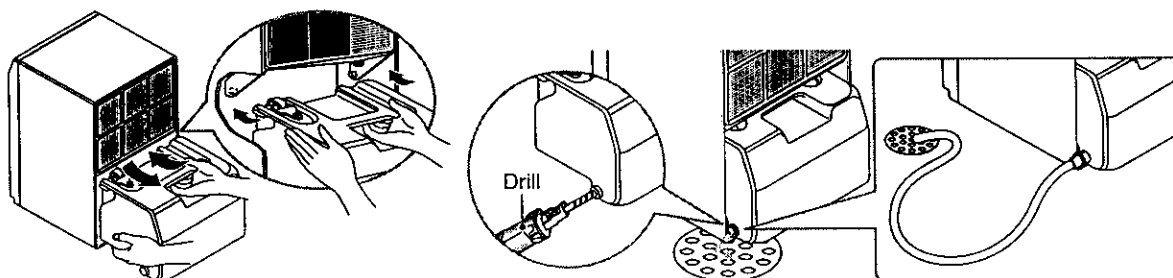

MAINTENANCE

GRILLE AND CASE

To clean the case: Use water and a mild detergent. Do not use bleach or an abrasive cleaner.

To clean the grille: Use a vacuum with an attachment or brush.

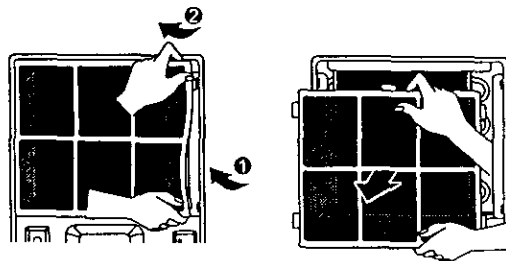

AIR FILTER

The air filter is on the back of the dehumidifier. It should be checked and cleaned at least every 30 days or more often if necessary.

TO REMOVE:

Flex the filter at the lower right corner and slide the upper right side to the left. Release all of the tabs and remove the filter. Wash it in warm soapy water. Rinse and let the filter dry before replacing it.

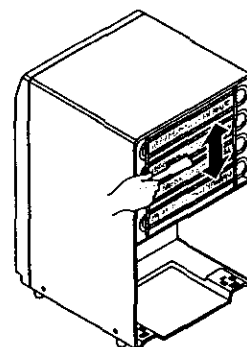

CLEANING INSIDE THE UNIT

After removing the air filter, clean the coil on the inside with a soft brush to remove any soft and wet soil.

NOTE: Do not allow water to enter the electrical/machine compartment through the circular opening behind the coil.

Do not spray the coil with a hose.

GENERAL CLEANING

- Dust the front grille and the side panels with a soft brush or use the dusting attachment of your vacuum.
- If cabinet paint chips, you can touch up the paint with a good grade enamel to prevent rust.

WATER BUCKET CLEANING

- Every few weeks, rinse the inside of the water bucket with a mild detergent to prevent growth of mold, mildew, and bacteria.

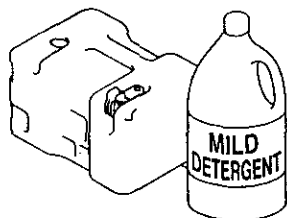

ENGLISH

TROUBLESHOOTING

Problem	Possible Causes	What To Do
<i>Dehumidifier does not start</i>	The dehumidifier power cord is unplugged	• Make sure the dehumidifier plug is pushed completely into the outlet.
	The fuse is blown or circuit breaker is tripped.	• Check the house fuse or circuit breaker box and replace the fuse or reset the breaker.
	Water bucket is full	• The dehumidifier automatically turns off when this occurs. Empty the bucket.
	Bucket is not installed.	• Make sure a bucket in the right place.
<i>Dehumidifier does not dry the air as it should</i>	Did not allow enough time to remove the moisture.	• When first installed, allow at least 3 or 4 days to maintain the desired dryness.
	Airflow is restricted.	• Make sure there are no curtains, blinds or furniture blocking the front or back of the dehumidifier.
	The Humidity Control may not be set low Humidity.	• Press the  Humidity Control button to lower the humidity.
	Doors and windows may not be closed tightly.	• Check that all doors, windows and other openings are securely closed.
	Clothes dryer may be blowing moisture-laden air into the room.	• Install the dehumidifier away from the dryer. The dryer should be vented to the outside.
	Room temperature is too low.	• The unit will not operate satisfactorily if the room temperature is below 65°F. (18°C.).
<i>Dehumidifier runs too much</i>	Area to be dehumidified is too large.	• Check with your dealer to see if the capacity is adequate.
	Doors and windows are open.	• Close all doors and windows to the outside.
<i>Frost appears on the coils</i>	Dehumidifier has been recently turned on or room temperature is below 65°F. (18°C.).	• This is normal. Frost will usually disappear within 60 minutes.
<i>Fan noise</i>	Air is moving through the dehumidifier.	• This is normal.
<i>Water on floor</i>	Bucket drain hose connection may be loose.	• Check the hose if one is attached.
	Water bucket is not all the way in.	• See the Removing and Emptying The Water Bucket.

REPAIR PARTS

Dehumidifier

Model No. 580.52650

To order Parts call Toll Free

1-800-4-MY-HOME®(1-800-469-4663)

CAUTION: Use the Kenmore part number on all orders, **not** the illustration number.

OUTER CASE PARTS AND CONTROL PART

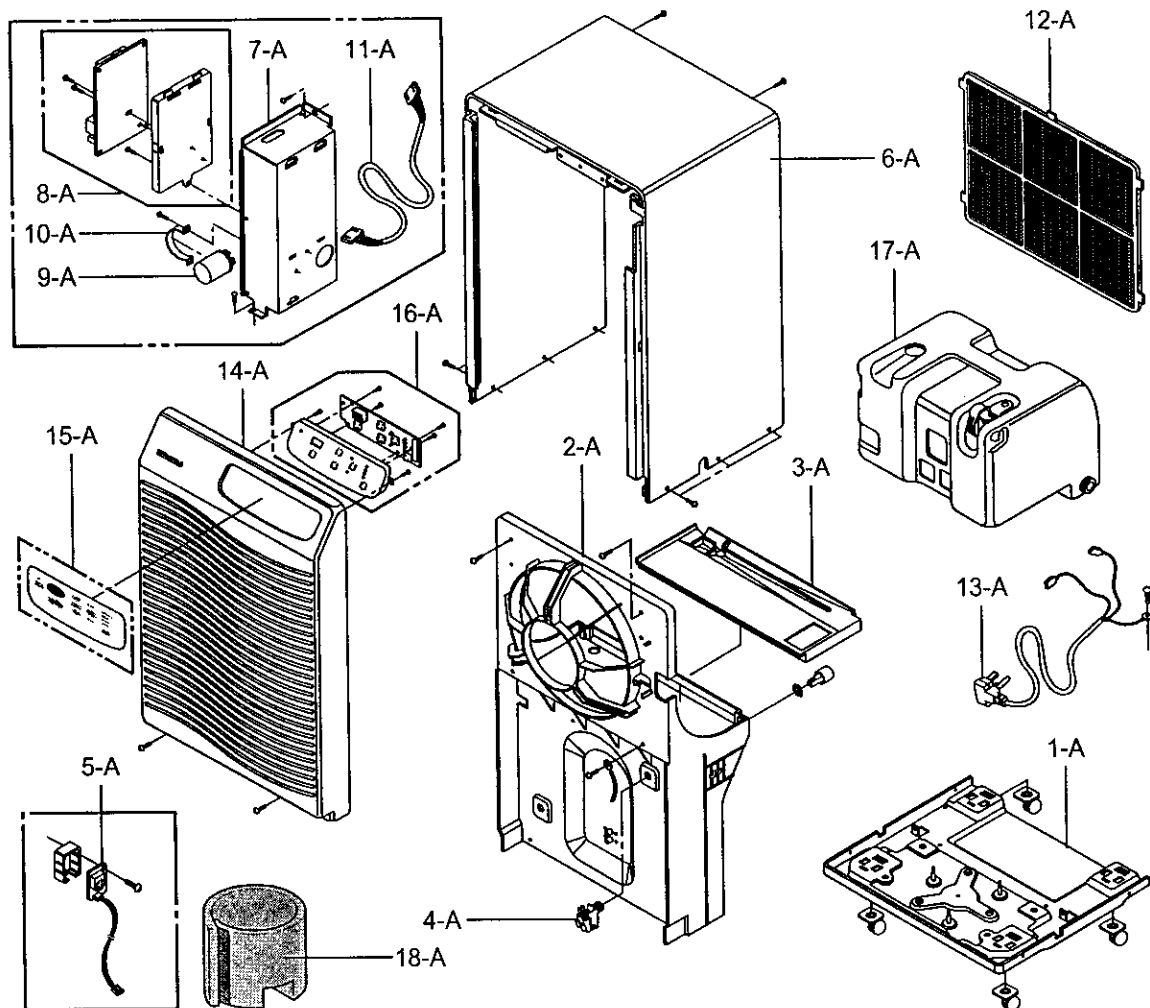

ENGLISH

POS. NO	PART NO	DESCRIPTION	POS. NO	PART NO	DESCRIPTION
1-A	3041AD2007C	BASE, ASSY WELD	10-A	4H00442J	CLAMP, CAPACITOR
2-A	3661A30003B	HOUSING ASSY, SINGLE	11-A	6631AQ3132U	CONNECTOR ASSY
3-A	3086A30006A	DRAIN PAN	12-A	5230AD3005A	FILTER, AIR
4-A	6600A30003C	SWITCH ASSY, MICRO	13-A	6411A20001L	POWER CORD ASSY
5-A	6500A90002A	SENSOR	14-A	3530A10006F	GRILLE, FRONT
6-A	3090A10001J	CABINET	15-A	3831A20016A	ESCUTCHEON
7-A	4994A20012A	CONTROL BOX, SINGLE	16-A	3551A30030A	COVER ASSY, DISPLAY
8-A	6871A10016A	PWB ASSY, MAIN	17-A	4838A20005A	TANK, BUCKET
9-A	0CZZA20001F	CAPACITOR	18-A	3096AR2871H	SOUND PROOF

580.52650

CAUTION: When ordering parts, use the Kenmore part number not the position number.

CYCLE PARTS

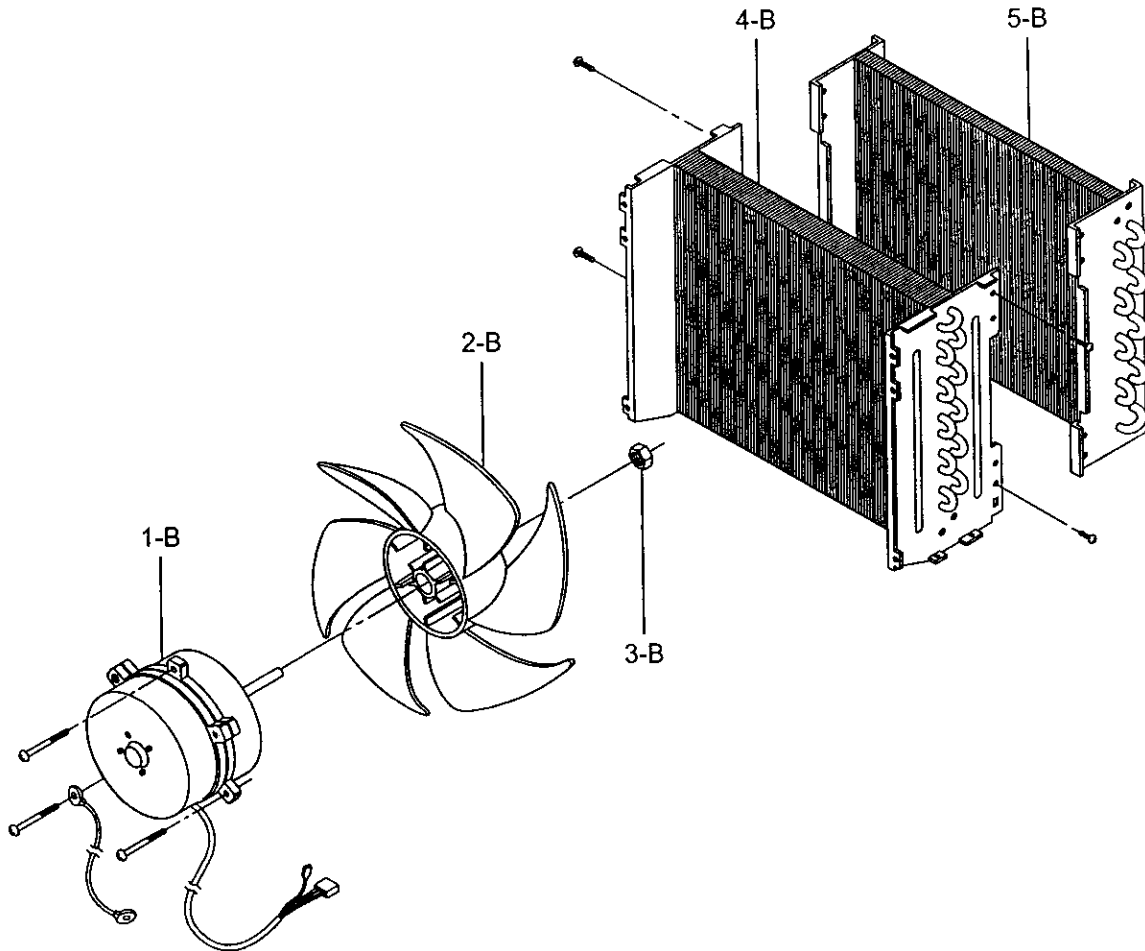

POS. NO	PART NO	DESCRIPTION
1-B	4681A20034C	MOTOR ASSY, SINGLE
2-B	5900AD2013A	FAN ASSY, PROPELLER
3-B	4H02861A	FAN, NUT
4-B	5403A20027D	CONDENSER ASSY
5-B	5421A20046C	EVAPORATOR ASSY

580.52650

CAUTION: When ordering parts, use the Kenmore part number **not** the position number.

COMPRESSOR PARTS

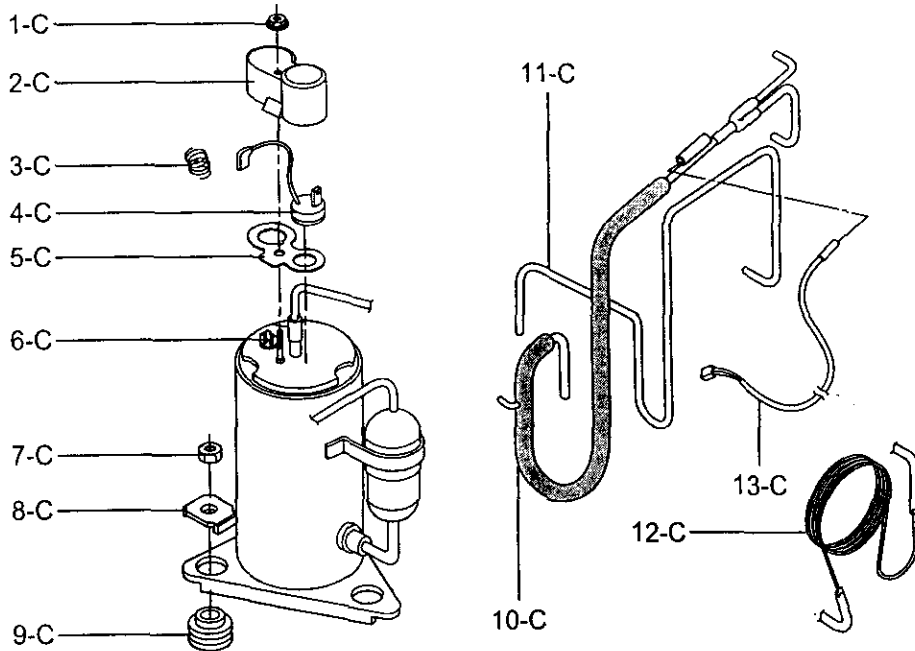

ENGLISH

POS. NO	PART NO	DESCRIPTION
1-C	4H00947A	NUT, TERMINAL COVER
2-C	3550-CL001D	TERMINAL COVER
3-C	4970U-L002A	SPRING, O.L.P
4-C	6750U-L035A	O.L.P
5-C	4986U-L001B	GASKET
6-C	5416A90003A	COMPRESSOR
7-C	1NHA0801206	NUT, HEXAGON(1)
8-C	4810AR4155A	BRACKET, WASHER
9-C	4830A30005A	BUSHING
10-C	5211A20237A	TUBE ASSY, SUCTION
11-C	5211A10070B	TUBE ASSY, DISCHARGE
12-C	5211A10085B	TUBE ASSY, CAPILLARY
13-C	3Q35015Q	THERMISTOR ASSY