

Owner's Manual

CRAFTSMAN®

**25.0 HP
ELECTRIC START
48" MOWER
AUTOMATIC
LAWN TRACTOR**

Model No.
917.272262

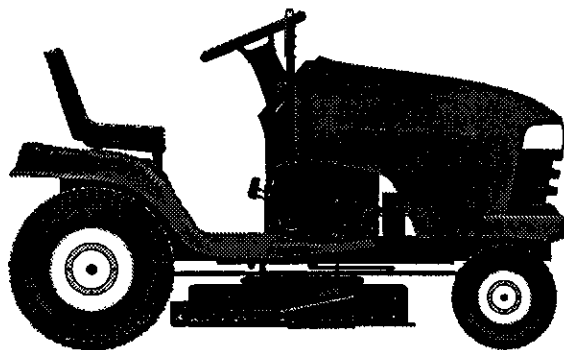

- Safety
- Assembly
- Operation
- Maintenance
- Repair Parts



This product has a low emission engine which operates differently from previously built engines. Before you start the engine, read and understand this Owner's Manual.

CAUTION:

Read and follow all Safety Rules and Instructions before operating this equipment.

For answers to your questions about this product, Call:

1-800-659-5917
Sears Craftsman Help Line
5 am - 5 pm, Mon - Sat

Sears, Roebuck and Co., Hoffman Estates, IL 60179
Visit our Craftsman website: www.sears.com/craftsman

TABLE OF CONTENTS

Warranty	2	Maintenance	18
Safety Rules	3	Service and Adjustments	23
Product Specifications	6	Storage	29
Assembly	8	Troubleshooting	30
Operation	12	Repair Parts	34
Maintenance Schedule	18	Parts Ordering	Back Cover

WARRANTY

LIMITED TWO YEAR WARRANTY ON CRAFTSMAN RIDING EQUIPMENT PARTS

For two (2) years from the date of purchase, if this Craftsman Riding Equipment is maintained, lubricated and tuned up according to the instructions in the owner's manual, Sears will repair or replace, free of charge, any parts found to be defective in material or workmanship. Warranty service is available free of charge by returning your Craftsman riding equipment to your nearest Sears Service Center. In-home warranty service is available but a trip charge will apply. This warranty applies only while this product is in the United States.

This Warranty does not cover:

- Expendable items which become worn during normal use, such as blades, spark plugs, air cleaners, belts and oil filters.
- Tire replacement or repair caused by punctures from outside objects, such as nails, thorns, stumps, or glass.
- Repairs necessary because of operator abuse, including but not limited to, damage caused by towing objects beyond the capability of the riding equipment, impacting objects that bend the frame or crankshaft, or over speeding the engine.
- Repairs necessary because of operator negligence, including but not limited to, electrical and mechanical damage caused by improper storage, failure to use the proper grade and amount of engine oil, failure to keep the deck clear of flammable debris, or the failure to maintain the equipment according to the instructions contained in the owner's manual.
- Engine (fuel system) cleaning or repairs caused by fuel determined to be contaminated or oxidized (stale). In general, fuel should be used within thirty (30) days of its purchase date.
- Riding equipment used for commercial or rental purposes. A product is "used for commercial purpose" if it is used for any purpose other than single family household dwellings or in usage where profit is made.

LIMITED 90 DAY WARRANTY ON BATTERY

For ninety (90) days from date of purchase, if any battery included with this riding equipment proves defective in material or workmanship and our testing determines the battery will not hold a charge, Sears will replace the battery at no charge. Warranty service is available free of charge by returning your Craftsman riding equipment to your nearest Sears Service Center. In-home warranty service is available but a trip charge will apply. This warranty applies only while this product is in the United States.

TO LOCATE THE NEAREST SEARS SERVICE CENTER OR TO SCHEDULE IN-HOME WARRANTY SERVICE, SIMPLY CONTACT SEARS AT 1-800-4-MY-HOME

This Warranty gives you specific legal rights, and you may also have other rights which may vary from state to state.

Sears, Roebuck and Co., D/817 WA, Hoffman Estates, IL 60179

SAFETY RULES

IMPORTANT: This cutting machine is capable of amputating hands and feet and throwing objects. Failure to observe the following safety instructions could result in serious injury or death.

I. GENERAL OPERATION

- Read, understand, and follow all instructions in the manual and on the machine before starting.
- Only allow responsible adults, who are familiar with the instructions, to operate the machine.
- Clear the area of objects such as rocks, toys, wire, etc., which could be picked up and thrown by the blade.
- Be sure the area is clear of other people before mowing. Stop machine if anyone enters the area.
- Never carry passengers.
- Do not mow in reverse unless absolutely necessary. Always look down and behind before and while backing.
- Be aware of the mower discharge direction and do not point it at anyone. Do not operate the mower without either the entire grass catcher or the guard in place.
- Slow down before turning.
- Never leave a running machine unattended. Always turn off blades, set parking brake, stop engine, and remove keys before dismounting.
- Turn off blades when not mowing.
- Stop engine before removing grass catcher or unclogging chute.
- Mow only in daylight or good artificial light.
- Do not operate the machine while under the influence of alcohol or drugs.
- Watch for traffic when operating near or crossing roadways.
- Use extra care when loading or unloading the machine into a trailer or truck.
- Data indicates that operators, age 60 years and above, are involved in a large percentage of riding mower-related injuries. These operators should evaluate their ability to operate the riding mower safely enough to protect themselves and others from serious injury.
- Keep machine free of grass, leaves or other debris build-up which can touch hot exhaust / engine parts and burn. Do not allow the mower deck to plow leaves or other debris which can cause build-up to occur. Clean any oil or fuel spillage before operating or storing the machine. Allow machine to cool before storage.

II. SLOPE OPERATION

Slopes are a major factor related to loss-of-control and tipover accidents, which can result in severe injury or death. All slopes require extra caution. If you cannot back up the slope or if you feel uneasy on it, do not mow it.

DO:

- Mow up and down slopes, not across.
- Remove obstacles such as rocks, tree limbs, etc.
- Watch for holes, ruts, or bumps. Uneven terrain could overturn the machine. *Tall grass can hide obstacles.*
- Use slow speed. Choose a low gear so that you will not have to stop or shift while on the slope.
- Follow the manufacturer's recommendations for wheel weights or counterweights to improve stability.
- Use extra care with grass catchers or other attachments. These can change the stability of the machine.
- Keep all movement on the slopes *slow* and *gradual*. Do not make sudden changes in speed or direction.
- Avoid starting or stopping on a slope. If tires lose traction, disengage the blades and proceed slowly *straight* down the slope.

DO NOT:

- *Do not* turn on slopes unless necessary, and then, turn slowly and gradually downhill, if possible.
- *Do not* mow near drop-offs, ditches, or embankments. The mower could suddenly turn over if a wheel is over the edge of a cliff or ditch, or if an edge caves in.
- *Do not* mow on wet grass. Reduced traction could cause sliding.
- *Do not* try to stabilize the machine by putting your foot on the ground.
- *Do not* use grass catcher on steep slopes.

SAFETY RULES

III. CHILDREN

Tragic accidents can occur if the operator is not alert to the presence of children. Children are often attracted to the machine and the mowing activity. *Never* assume that children will remain where you last saw them.

- Keep children out of the mowing area and under the watchful care of another responsible adult.
- Be alert and turn machine off if children enter the area.
- Before and when backing, look behind and *down* for small children.
- Never carry children. They may fall off and be seriously injured or interfere with safe machine operation.
- Never allow children to operate the machine.
- Use extra care when approaching blind corners, shrubs, trees, or other objects that may obscure vision.

IV. SERVICE

- Use extra care in handling gasoline and other fuels. They are flammable and vapors are explosive.
 - Use only an approved container.
 - Never remove gas cap or add fuel with the engine running. Allow engine to cool before refueling. Do not smoke.
 - Never refuel the machine indoors.
 - Never store the machine or fuel container inside where there is an open flame, such as a water heater.

- Never run a machine inside a closed area.
- Keep nuts and bolts, especially blade attachment bolts, tight and keep equipment in good condition.
- Never tamper with safety devices. Check their proper operation regularly.
- Keep machine free of grass, leaves, or other debris build-up. Clean oil or fuel spillage. Allow machine to cool before storing.
- Stop and inspect the equipment if you strike an object. Repair, if necessary, before restarting.
- Never make adjustments or repairs with the engine running.
- Grass catcher components are subject to wear, damage, and deterioration, which could expose moving parts or allow objects to be thrown. Frequently check components and replace with manufacturer's recommended parts, when necessary.
- Mower blades are sharp and can cut. Wrap the blade(s) or wear gloves, and use extra caution when servicing them.
- Check brake operation frequently. Adjust and service as required.



- Be sure the area is clear of other people before mowing. Stop machine if anyone enters the area.
- Never carry passengers or children even with the blades off.
- Do not mow in reverse unless absolutely necessary. Always look down and behind before and while backing.
- Never carry children. They may fall off and be seriously injured or interfere with safe machine operation.
- Keep children out of the mowing area and under the watchful care of another responsible adult.
- Be alert and turn machine off if children enter the area.
- Before and when backing, look behind and down for small children.
- Mow up and down slopes (15° Max), not across.
- Remove obstacles such as rocks, tree limbs, etc.
- Watch for holes, ruts, or bumps. Uneven terrain could overturn the machine. Tall grass can hide obstacles.

SAFETY RULES

- Use slow speed. Choose a low gear so that you will not have to stop or shift while on the slope.
- Avoid starting or stopping on a slope. If tires lose traction, disengage the blades and proceed slowly straight down the slope.
- If machine stops while going uphill, disengage blades, shift into reverse and back down slowly.
- Do not turn on slopes unless necessary, and then, turn slowly and gradually downhill, if possible.

⚠ Look for this symbol to point out important safety precautions. It means **CAUTION!!! BECOME ALERT!!! YOUR SAFETY IS INVOLVED.**

⚠ CAUTION: In order to prevent accidental starting when setting up, transporting, adjusting or making repairs, always disconnect spark plug wire and place wire where it cannot contact spark plug.

⚠ CAUTION: Do not coast down a hill in neutral, you may lose control of the tractor.

⚠ CAUTION: Tow only the attachments that are recommended by and comply with specifications of the manufacturer of your tractor. Use common sense when towing. Operate only at the lowest possible speed when on a slope. Too heavy of a load, while on a slope, is dangerous. Tires can lose traction with the ground and cause you to lose control of your tractor.

⚠ WARNING: Engine exhaust, some of its constituents, and certain vehicle components contain or emit chemicals known to the State of California to cause cancer and birth defects or other reproductive harm.

⚠ WARNING: Battery posts, terminals and related accessories contain lead and lead compounds, chemicals known to the State of California to cause cancer and birth defects or other reproductive harm. **Wash hands after handling.**

PRODUCT SPECIFICATIONS

GASOLINE CAPACITY AND TYPE:	3.5 GALLONS UNLEADED REGULAR
OIL TYPE (API-SF-SJ):	SAE 30 (ABOVE 32°F) SAE 5W-30 (BELOW 32°F)
OIL CAPACITY:	W/FILTER: 4.0 PINTS W/OFILTER: 3.75 PINTS
SPARK PLUG (GAP: .040")	CHAMPION RC12YC
GROUND SPEED (MPH):	FORWARD: 0-5.5 REVERSE: 0-2.4
TIRE PRESSURE:	FRONT: 14 PSI REAR: 10 PSI
CHARGING SYSTEM:	16 AMPS @ 3600 RPM
BATTERY:	AMP/HR: 30 MIN. CCA: 240 CASE SIZE: U1R
BLADE BOLT TORQUE:	45-55 FT. LBS.

CONGRATULATIONS on your purchase of a new tractor. It has been designed, engineered and manufactured to give you the best possible dependability and performance.

Should you experience any problem you cannot easily remedy, please contact a Sears or other qualified service center.

We have competent, well-trained technicians and the proper tools to service or repair this tractor.

Please read and retain this manual. The instructions will enable you to assemble and maintain your tractor properly. Always observe the "SAFETY RULES".

REPAIR AGREEMENT

A Repair Agreement is available on this product. Contact your nearest Sears store for details.

CUSTOMER RESPONSIBILITIES

- Read and observe the safety rules.
- Follow a regular schedule in maintaining, caring for and using your tractor.
- Follow the instructions under "Maintenance" and "Storage" sections of this owner's manual.

⚠WARNING: This tractor is equipped with an internal combustion engine and should not be used on or near any unimproved forest-covered, brush-covered or grass-covered land unless the engine's exhaust system is equipped with a spark arrester meeting applicable local or state laws (if any). If a spark arrester is used, it should be maintained in effective working order by the operator.

In the state of California the above is required by law (Section 4442 of the California Public Resources Code). Other states may have similar laws. Federal laws apply on federal lands. A spark arrester for the muffler is available through your nearest Sears service center (See REPAIR PARTS section of this manual).

UNASSEMBLED PARTS



Steering Wheel

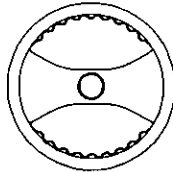

Seat



(1) Washer
17/32 x 1-3/16 x 12 Gauge

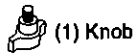

(5) Retainer Springs
(double loop)



(2) Retainer Springs (single loop)

Mower

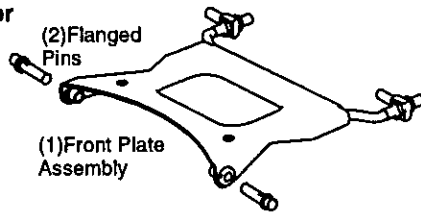

(4) Adjusting Bar

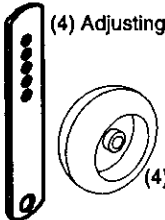

Gauge Wheels

(4) Retainer Springs
(double loop)

(4) Locknut
3/8-16

(4) Wheels

(4) Washers
3/8 x 3/4 x 14 Ga.

(4) Clevis Pins

(4) Shoulder Bolt

Nose Roller



(2) Locknuts
5/16-18



(2) Hex Bolts
5/16-18 x 1

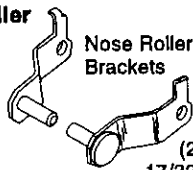
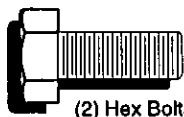

(2) Washers
17/32 x 7/8 x 16 Ga.



Video Cassette

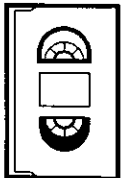

Keys

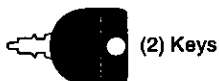

Slope Sheet

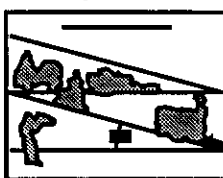

ASSEMBLY

Your new tractor has been assembled at the factory with exception of those parts left unassembled for shipping purposes. To ensure safe and proper operation of your tractor all parts and hardware you assemble must be tightened securely. Use the correct tools as necessary to insure proper tightness. Review the video cassette before you begin.

TOOLS REQUIRED FOR ASSEMBLY

A socket wrench set will make assembly easier. Standard wrench sizes you need are listed below.

- | | |
|-------------------------|-------------------------------------|
| (1) 9/16" wrench | (1) 3/4" Socket w/
drive ratchet |
| (1) 1/2" wrench | (1) Pliers |
| (1) Utility knife | |
| (1) Tire pressure gauge | |

When right or left hand is mentioned in this manual, it means, from your point of view, when you are in the operating position (seated behind the steering wheel).

TO REMOVE TRACTOR FROM CARTON

UNPACK CARTON

1. Remove all accessible loose parts and parts cartons from carton.
2. Cut, from top to bottom, along lines on all four corners of carton, and lay panels flat.
3. Remove mower and packing materials.
4. Check for any additional loose parts or cartons and remove.

BEFORE REMOVING TRACTOR FROM SKID

ATTACH STEERING WHEEL

1. Remove hex nut and large flat washer from steering shaft.
2. Position front wheels of the tractor so they are pointing straight forward.
3. Slide the steering sleeve over the steering shaft.
4. Position steering wheel so cross bars are horizontal (left to right) and slide onto steering wheel adapter.
5. Secure steering wheel to steering shaft with hex nut and large flat washer previously removed. Tighten securely.
6. Snap steering wheel insert into center of steering wheel.
7. Remove protective materials from tractor hood and grill.

IMPORTANT: Check for and remove any staples in skid that may puncture tires where tractor is to roll off skid.

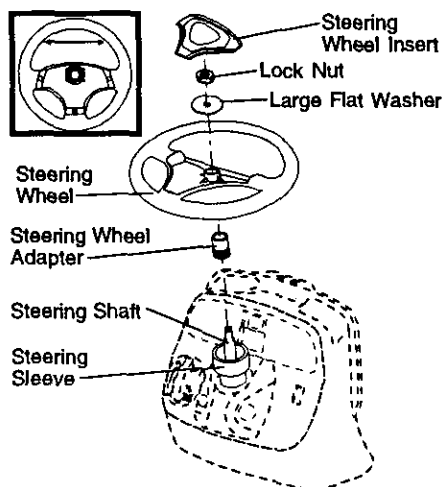

HOW TO SET UP YOUR TRACTOR

CHECK BATTERY

1. Lift hood to raised position.
- NOTE:** If this battery is put into service after month and year indicated on label (label located between terminals) charge battery for minimum of one hour at 6-10 amps. (See "BATTERY" in Maintenance section of this manual for charging instructions).

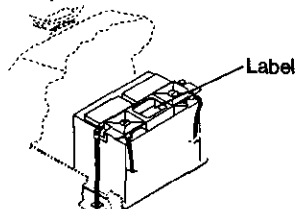

INSTALL SEAT

Adjust seat before tightening adjustment knob.

1. Remove adjustment knob and flat washer securing seat to cardboard packing and set aside for assembly of seat to tractor.
 2. Pivot seat upward and remove from the cardboard packing. Remove the cardboard packing and discard.
 3. Place seat on seat pan so head of shoulder bolt is positioned over large slotted hole in pan.
- 8

4. Push down on seat to engage shoulder bolt in slot and pull seat towards rear of tractor.
5. Pivot seat and pan forward and assemble adjustment knob and flat washer loosely. Do not tighten.
6. Lower seat into operating position and sit in seat.
7. Slide seat until a comfortable position is reached which allows you to press clutch/brake pedal all the way down.
8. Get off seat without moving its adjusted position.
8. Raise seat and tighten adjustment knob securely.

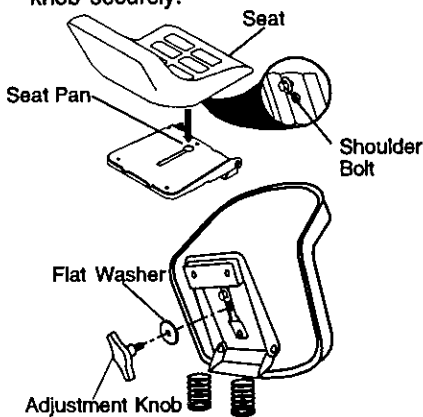

NOTE: You may now roll or drive your tractor off the skid. Follow the appropriate instruction below to remove the tractor from the skid.

TO ROLL TRACTOR OFF SKID (See Operation section for location and function of controls)

1. Press lift lever plunger and raise attachment lift lever to its highest position.
2. Release parking brake by depressing brake pedal.
3. Place freewheel control in freewheeling position to disengage transmission (See "TO TRANSPORT" in the Operation section of this manual).
4. Roll tractor forward off skid.

TO DRIVE TRACTOR OFF SKID (See Operation section for location and function of controls)

▲ WARNING: Before starting, read, understand and follow all instructions in the Operation section of this manual. Be sure tractor is in a well-ventilated area. Be sure the area in front of tractor is clear of other people and objects.

1. Be sure all the above assembly steps have been completed.
2. Check engine oil level and fill fuel tank with gasoline.
3. Place freewheel control in "transmission engaged" position.
4. Sit on seat in operating position, depress brake pedal and set the parking brake.
5. Press lift lever plunger and raise attachment lift lever to its highest position.
6. Start the engine. After engine has started, move throttle control to idle position.
7. Release parking brake.
8. Slowly depress forward drive pedal and drive tractor off skid.
9. Apply brake to stop tractor and set parking brake.
10. Turn ignition key to "OFF" position. Continue with the instructions that follow.

ASSEMBLE GAUGE WHEELS TO MOWER DECK

The gauge wheels are designed to keep the mower deck in proper position when operating mower. Be sure they are properly adjusted to ensure optimum mower performance.

1. Slide gauge wheel bar down into bracket channel, Be sure that gauge wheel bar aligning holes are on top. Assemble gauge wheels as shown using shoulder bolts, 3/8 washers and 3/8-16 center locknuts and tighten securely.
2. For ease of mower to tractor assembly, raise gauge wheels to highest position and retain with clevis pins and spring retainers.

NOTE: Adjust gauge wheels before operating mower. See "TO ADJUST GAUGE WHEELS" in the Operation section of this manual.

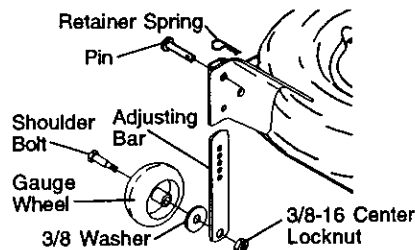

TO ATTACH NOSE ROLLER

1. Position brackets, 17/32 x 7/8 x 16 gauge washers, and nose roller between deck mounting brackets as shown. Be sure to position brackets on correct side, as shown.
2. Install hex bolts and lock nuts as shown. Tighten hardware securely.

NOTE: Be sure bracket tabs are positioned in tab holes in deck brackets.

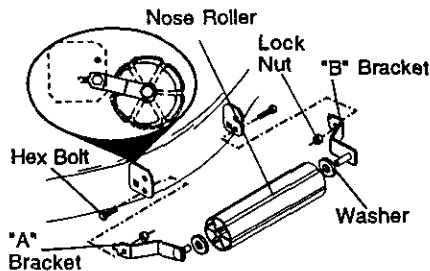

INSTALL MOWER AND DRIVE BELT

Be sure tractor is on level surface and mower suspension arms are raised with attachment lift control. Engage parking brake.

1. Cut and remove ties securing anti-sway bar and belts. Swing anti-sway bar to left side of mower deck.
 2. Slide mower under tractor with deflector shield to right side of tractor.
- IMPORTANT:** Check belt for proper routing in all mower pulley grooves.
3. If equipped, turn height adjustment knob counterclockwise until it stops.
 4. Lower mower linkage with attachment lift control.
 5. Be sure belt tension rod is in disengaged position.

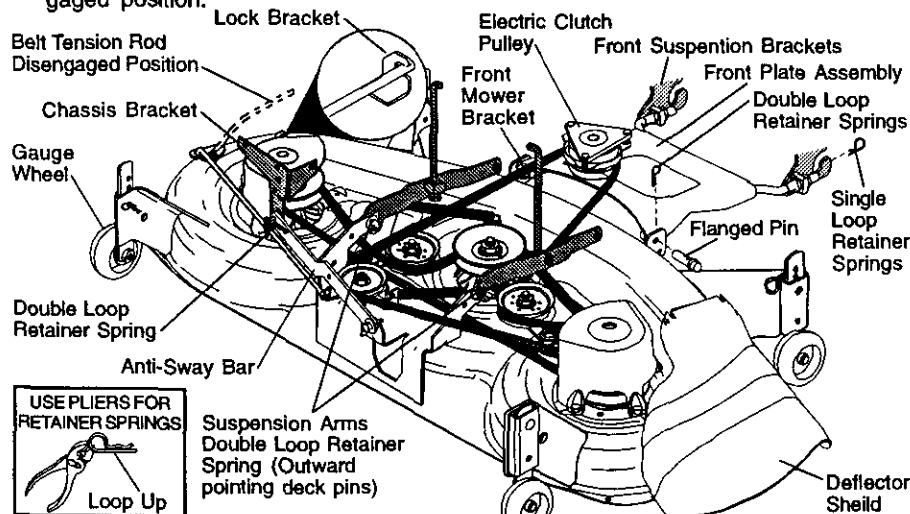

6. Install belt into electric clutch pulley groove.
7. Place the suspension arms on outward pointing deck pins. Retain with double loop retainer spring with loops up as shown.
8. Install front plate assembly to tractor suspension brackets and retain with single loop retainer springs as shown.
9. Position front plate assembly between front mower brackets. Raise deck and plate assembly to align holes and insert flanged pins. Secure pins with double loop retainer springs between the plate assembly and mower brackets.

NOTE: To assist in locating hole in flanged pin, the hole in pin is inline with notch on head of pin. If necessary, move side-to-side to give space between plate and mower brackets.

IMPORTANT: Check belt for proper routing in all mower pulley grooves.

10. Engage belt tension rod by pushing rod into locking bracket.

CAUTION: Belt tension rod is spring loaded. Have a tight grip on rod and engage slowly.

11. Connect anti-sway bar to chassis bracket under left footrest and retain with double loop retainer spring.
12. If equipped, turn height adjustment knob clockwise to remove slack from mower suspension.
13. Raise deck to highest position.
14. Adjust gauge wheels before operating mower as shown in the Operation section of this manual.

CHECK TIRE PRESSURE

The tires on your tractor were overinflated at the factory for shipping purposes. Correct tire pressure is important for best cutting performance.

- Reduce tire pressure to PSI shown in "PRODUCT SPECIFICATIONS" section of this manual.

CHECK DECK LEVELNESS

For best cutting results, mower housing should be properly leveled. See "TO LEVEL MOWER HOUSING" in the Service and Adjustments section of this manual.

CHECK FOR PROPER POSITION OF ALL BELTS

See the figures that are shown for replacing motion and mower blade drive belts in the Service and Adjustments section of this manual. Verify that the belts are routed correctly.

CHECK BRAKE SYSTEM

After you learn how to operate your tractor, check to see that the brake is properly adjusted. See "TO ADJUST BRAKE" in the Service and Adjustments section of this manual.

✓CHECKLIST

BEFORE YOU OPERATE AND ENJOY YOUR NEW TRACTOR, WE WISH TO ASSURE THAT YOU RECEIVE THE BEST PERFORMANCE AND SATISFACTION FROM THIS QUALITY PRODUCT.

PLEASE REVIEW THE FOLLOWING CHECKLIST:

- ✓ All assembly instructions have been completed.
- ✓ No remaining loose parts in carton.
- ✓ Battery is properly prepared and charged. (Minimum 1 hour at 6 amps).
- ✓ Seat is adjusted comfortably and tightened securely.
- ✓ All tires are properly inflated. (For shipping purposes, the tires were overinflated at the factory).
- ✓ Be sure mower deck is properly leveled side-to-side/front-to-rear for best cutting results. (Tires must be properly inflated for leveling).
- ✓ Check mower and drive belts. Be sure they are routed properly around pulleys and inside all belt keepers.
- ✓ Check wiring. See that all connections are still secure and wires are properly clamped.
- ✓ Before driving tractor, be sure free-wheel control is in drive position.

WHILE LEARNING HOW TO USE YOUR TRACTOR, PAY EXTRA ATTENTION TO THE FOLLOWING IMPORTANT ITEMS:

- ✓ Engine oil is at proper level.
- ✓ Fuel tank is filled with fresh, clean, regular unleaded gasoline.
- ✓ Become familiar with all controls - their location and function. Operate them before you start the engine.
- ✓ Be sure brake system is in safe operating condition.
- ✓ It is important to purge the transmission before operating your tractor for the first time. Follow proper starting and transmission purging instructions (See "TO START ENGINE" and "PURGE TRANSMISSION" in the Operation section of this manual).

OPERATION

These symbols may appear on your tractor or in literature supplied with the product. Learn and understand their meaning.

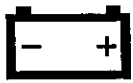

BATTERY



CAUTION OR WARNING



REVERSE



FORWARD



FAST



SLOW



ENGINE ON



ENGINE OFF



OIL PRESSURE



LIGHTS ON



OVER TEMP LIGHT



MOWER LIFT



FUEL



CHOKE



MOWER HEIGHT



PARKING BRAKE LOCKED



UNLOCKED



ATTACHMENT CLUTCH ENGAGED



REVERSE



NEUTRAL



HIGH



LOW



PARKING BRAKE



IGNITION



ATTACHMENT CLUTCH DISENGAGED



KEEP AREA CLEAR



SLOPE HAZARDS



(SEE SAFETY RULES SECTION)



DANGER, KEEP HANDS AND FEET AWAY

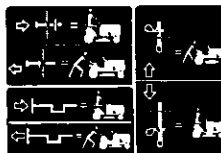

FREE WHEEL
(Automatic Models only)

KNOW YOUR TRACTOR

READ THIS OWNER'S MANUAL AND SAFETY RULES BEFORE OPERATING YOUR TRACTOR

Compare the illustrations with your tractor to familiarize yourself with the locations of various controls and adjustments. Save this manual for future reference.

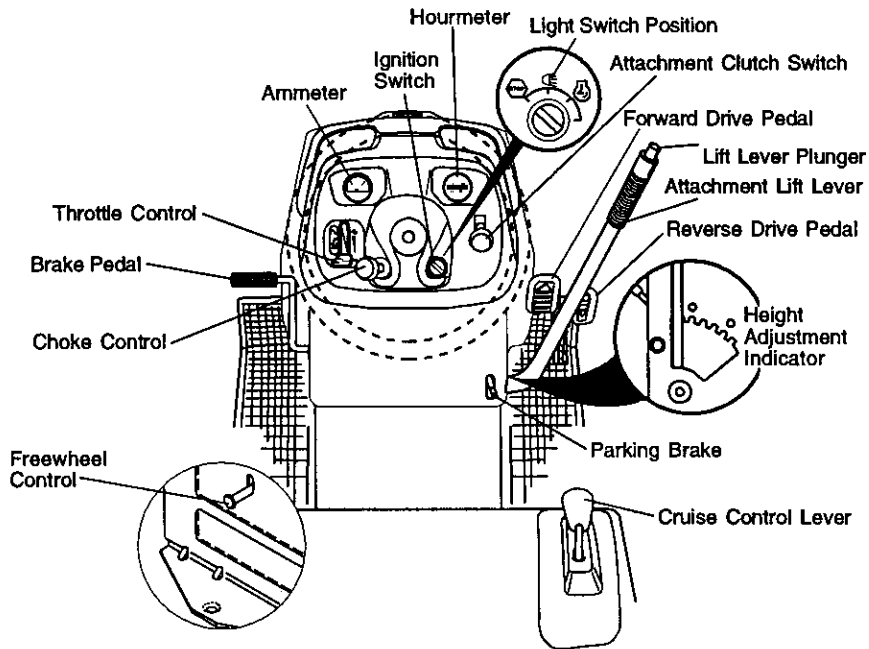

Our tractors conform to the safety standards of the American National Standards Institute.

ATTACHMENT CLUTCH SWITCH: Used to engage the mower blades, or other attachments mounted to your tractor.

LIGHT SWITCH: Turns the headlights on and off.

THROTTLE CONTROL - Used to control engine speed.

CHOKE CONTROL - Used when starting a cold engine.

BRAKE PEDAL: Used for braking the tractor and starting the engine.

FREEWHEEL CONTROL: Disengages transmission for pushing or slowly towing the tractor with the engine off.

ATTACHMENT LIFT LEVER: Used to raise, lower and adjust the mower deck or other attachments mounted to your tractor.

LIFT LEVER PLUNGER: Used to release attachment lift lever when changing its position.

IGNITION SWITCH: Used for starting and stopping the engine.

AMMETER: Indicates battery charging (+) or discharging (-).

PARKING BRAKE: Locks clutch/brake into the brake position.

FORWARD DRIVE PEDAL - Used for forward movement of tractor.

REVERSE DRIVE PEDAL - Used for reverse movement of tractor.

CRUISE CONTROL LEVER - Used to set forward movement of tractor at desired speed without holding the forward drive pedal.

HOURLMETER - Indicates hours of operation.



The operation of any tractor can result in foreign objects thrown into the eyes, which can result in severe eye damage. Always wear safety glasses or eye shields while operating your tractor or performing any adjustments or repairs. We recommend a wide vision safety mask over spectacles, or standard safety glasses.

HOW TO USE YOUR TRACTOR TO SET PARKING BRAKE

Your tractor is equipped with an operator presence sensing switch. When engine is running, any attempt by the operator to leave the seat without first setting the parking brake will shut off the engine.

1. Depress brake pedal into full "BRAKE" position and hold.
2. Place parking brake lever in "ENGAGED" position and release pressure from brake pedal. Pedal should remain in "BRAKE" position. Make sure parking brake will hold tractor secure.

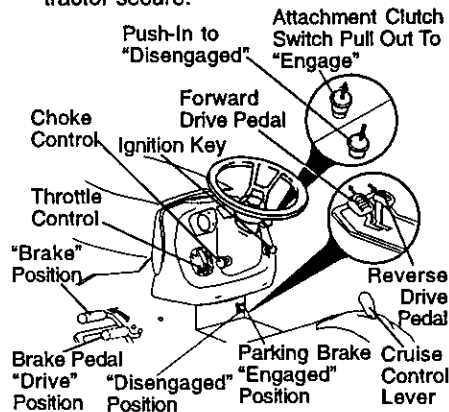

STOPPING

MOWER BLADES -

- To stop mower blades, move attachment clutch switch to "DISENGAGED" position.

GROUND DRIVE -

- To stop ground drive, depress brake pedal into full "BRAKE" position.

IMPORTANT: Forward and reverse drive pedals return to neutral position when not depressed.

ENGINE -

- Move throttle control to slow position.
- NOTE:** Failure to move throttle control to slow position and allowing engine to idle before stopping may cause engine to "backfire".
- Turn ignition key to "OFF" position and remove key. Always remove key when leaving tractor to prevent unauthorized use.
- Never use choke to stop engine.

IMPORTANT: Leaving the ignition switch in any position other than "OFF" will cause the battery to be discharged, (dead).

NOTE: Under certain conditions when tractor is standing idle with the engine running, hot engine exhaust gases may cause "browning" of grass. To eliminate this possibility, always stop engine when stopping tractor on grass areas.

CAUTION: Always stop tractor completely, as described above, before leaving the operator's position; to empty grass catcher, etc.

THROTTLE CONTROL

Always operate engine at full throttle.

- Operating engine at less than full throttle reduces the battery charging rate.
- Full throttle offers the best bagging and mower performance.

TO USE CHOKE CONTROL

Use choke control whenever you are starting a cold engine. Do not use to start a warm engine.

- To engage choke control, pull knob out. Slowly push knob in to disengage.

TO MOVE FORWARD AND BACKWARD

The direction and speed of movement is controlled by the forward and reverse drive pedals.

1. Start tractor and release parking brake.
2. Slowly depress forward or reverse drive pedal to begin movement. Ground speed increases the further down the pedal is depressed.

TO USE CRUISE CONTROL

The cruise control feature can be used for forward travel only.

1. With forward drive pedal depressed to desired speed, move cruise control lever forward to "SET" position and hold while lifting your foot off the pedal, then release the cruise control lever.

To disengage the cruise control, pull the lever backward to "OFF" position, or fully depress the brake pedal.

TO ADJUST MOWER CUTTING HEIGHT

The position of the attachment lift lever determines the cutting height.

- Grasp lift lever.
- Press plunger with thumb and move lever to desired position.

The cutting height range is approximately 1-1/2 to 4". The heights are measured from the ground to the blade tip with the engine not running. These heights are approximate and may vary depending upon soil conditions, height of grass and types of grass being mowed.

- The average lawn should be cut to approximately 2-1/2 inches during the cool season and to over 3 inches during hot months. For healthier and better looking lawns, mow often and after moderate growth.
- For best cutting performance, grass over 6 inches in height should be mowed twice. Make the first cut relatively high; the second to desired height.

TO ADJUST GAUGE WHEELS

Gauge wheels are properly adjusted when they are slightly off the ground when mower is at the desired cutting height in operating position. Gauge wheels then keep the deck in proper position to help prevent scalping in most terrain conditions.

NOTE: Be sure tractor is on a flat level surface.

1. Lower mower and adjust mower to desired cutting height.
2. Remove retainer spring and clevis pin which secure each gauge wheel bar.
3. Lower gauge wheels to ground. Raise gauge wheels slightly to align holes in bracket and gauge wheel bar and insert clevis pin. Gauge wheels should be slightly off the ground.
4. Replace retainer spring into clevis pin.
5. Be sure all gauge wheels are in the same setting.

IMPORTANT: Be sure to readjust gauge wheels if you change the cutting height of the mower deck.

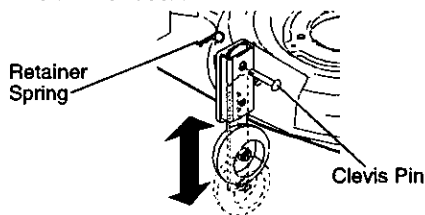

TO OPERATE MOWER

Your tractor is equipped with an operator presence sensing switch. Any attempt by the operator to leave the seat with the engine running and the attachment clutch engaged will shut off the engine.

1. Select desired height of cut.
2. Start mower blades by engaging attachment clutch control.

TO STOP MOWER BLADES - disengage attachment clutch control.

CAUTION: Do not operate the mower without either the entire grass catcher, on mowers so equipped, or the deflector shield in place.

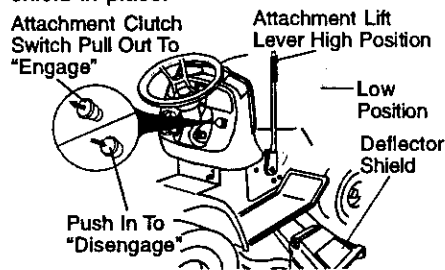

TO OPERATE ON HILLS

CAUTION: Do not drive up or down hills with slopes greater than 15° and do not drive across any slope.

- Choose the slowest speed before starting up or down hills.
- Avoid stopping or changing speed on hills.
- If stopping is absolutely necessary, push brake pedal quickly to brake position and engage parking brake.
- To restart movement, slowly release parking brake and brake pedal.
- Slowly depress appropriate drive pedal to slowest setting.
- Make all turns slowly.

TO TRANSPORT

When pushing or towing your tractor, be sure to disengage transmission by placing freewheel control in freewheeling position. Free wheel control is located at the rear drawbar of tractor.

1. Raise attachment lift to highest position with attachment lift control.
 2. Pull freewheel control out and into the slot and release so it is held in the disengaged position.
- Do not push or tow tractor at more than two (2) MPH.
 - To re-engage transmission, reverse above procedure.

NOTE: To protect hood from damage when transporting your tractor on a truck or a trailer, be sure hood is closed and secured to tractor. Use an appropriate means of tying hood to tractor (rope, cord, etc.).

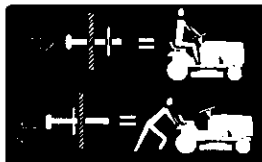

TOWING CARTS AND OTHER ATTACHMENTS

Tow only the attachments that are recommended by and comply with specifications of the manufacturer of your tractor. Use common sense when towing. Too heavy of a load, while on a slope, is dangerous. Tires can lose traction with the ground and cause you to lose control of your tractor.

BEFORE STARTING THE ENGINE CHECK ENGINE OIL LEVEL

The engine in your tractor has been shipped, from the factory, already filled with summer weight oil.

1. Check engine oil with tractor on level ground.
2. Remove oil fill cap/dipstick and wipe clean, reinsert the dipstick and screw cap tight, wait for a few seconds, remove and read oil level. If necessary, add oil until "FULL" mark on dipstick is reached. Do not overfill.
- For cold weather operation you should change oil for easier starting (See "OIL VISCOSITY CHART" in the Maintenance section of this manual).
- To change engine oil, see the Maintenance section in this manual.

ADD GASOLINE

- Fill fuel tank. Use fresh, clean, regular unleaded gasoline with a minimum of 87 octane. (Use of leaded gasoline will increase carbon and lead oxide deposits and reduce valve life). Do not mix oil with gasoline. Purchase fuel in quantities that can be used within 30 days to assure fuel freshness.

IMPORTANT: When operating in temperatures below 32°F(0°C), use fresh, clean winter grade gasoline to help insure good cold weather starting.

WARNING: Experience indicates that alcohol blended fuels (called gasohol or using ethanol or methanol) can attract moisture which leads to separation and formation of acids during storage. Acidic gas can damage the fuel system of an engine while in storage. To avoid engine problems, the fuel system should be emptied before storage of 30 days or longer. Drain the gas tank, start the engine and let it run until the fuel lines and carburetor are empty. Use fresh fuel next season. See Storage Instructions for additional information. Never use engine or carburetor cleaner products in the fuel tank or permanent damage may occur.

CAUTION: Fill to bottom of gas tank filler neck. Do not overfill. Wipe off any spilled oil or fuel. Do not store, spill or use gasoline near an open flame.

TO START ENGINE

When starting the engine for the first time or if the engine has run out of fuel, it will take extra cranking time to move fuel from the tank to the engine.

1. Be sure freewheel control is in the transmission engaged position.
2. Sit on seat in operating position, depress brake pedal and set parking brake.
3. Move attachment clutch to "DISENGAGED" position.
4. Move throttle control to fast position
5. Pull choke control out for a cold engine start attempt. For a warm engine start attempt the choke control may not be needed.

NOTE: Before starting, read the warm and cold starting procedures below.

6. Insert key into ignition and turn key clockwise to "START" position and release key as soon as engine starts. Do not run starter continuously for more than fifteen seconds per minute. If the engine does not start after several attempts, push choke control in, wait a few minutes and try again. If engine still does not start, pull the choke control out and retry.

WARM WEATHER STARTING (50° F and above)

7. When engine starts, slowly push choke control in until the engine begins to run smoothly. If the engine starts to run roughly, pull the choke control out slightly for a few seconds and then continue to push the control in slowly.
- The attachments and ground drive can now be used. If the engine does not accept the load, restart the engine and allow it to warm up for one minute using the choke as described above.

COLD WEATHER STARTING (50° F and below)

7. When engine starts, slowly push choke control in until the engine begins to run smoothly. Continue to push the choke control in small steps allowing the engine to accept small changes in speed and load, until the choke control is fully in. If the engine starts to run roughly, pull the choke control out slightly for a few seconds and then continue to push the control in slowly. This may require an engine warm-up period from several seconds to several minutes, depending on the temperature.

AUTOMATIC TRANSMISSION WARM UP
Before driving the unit in cold weather, the transmission should be warmed up as follows:

1. Be sure the tractor is on level ground.
 2. Release the parking brake and let the brake slowly return to operating position.
 3. Allow one minute for transmission to warm up. This can be done during the engine warm up period.
- The attachments can be used during the engine warm-up period after the transmission has been warmed up and may require the choke control be pulled out slightly.

NOTE: If at a high altitude (above 3000 feet) or in cold temperatures (below 32 F) the carburetor fuel mixture may need to be adjusted for best engine performance. See "TO ADJUST CARBURETOR" in the Service and Adjustments section of this manual.

PURGE TRANSMISSION

CAUTION: Never engage or disengage freewheel lever while the engine is running.

To ensure proper operation and performance, it is recommended that the transmission be purged before operating tractor for the first time. This procedure will remove any trapped air inside the transmission which may have developed during shipping of your tractor.

IMPORTANT: Should your transmission require removal for service or replacement, it should be purged after reinstallation before operating the tractor.

1. Place tractor safely on level surface with engine off and parking brake set.
2. Disengage transmission by placing freewheel control in freewheeling position (See "TO TRANSPORT" in this section of manual).
3. Sitting in the tractor seat, start engine. After the engine is running, move throttle control to slow position. Disengage parking brake.
4. Depress forward drive pedal to full forward position and hold for five (5) seconds and release pedal. Depress reverse drive pedal to full reverse position and hold for five (5) seconds and release pedal. Repeat this procedure three (3) times.

NOTE: During this procedure there will be no movement of drive wheels. The air is being removed from hydraulic drive system.

5. Shut-off engine and set parking brake.

6. Engage transmission by placing freewheel control in driving position (See "TO TRANSPORT" in this section of manual).
7. Sitting in the tractor seat, start engine. After the engine is running, move throttle control to half (1/2) speed. Disengage parking brake.
8. Drive tractor forward for approximately five feet then backwards for five feet. Repeat this driving procedure three times.

Your tractor is now purged and now ready for normal operation.

MOWING TIPS

- Mower should be properly leveled for best mowing performance. See "TO LEVEL MOWER HOUSING" in the Service and Adjustments section of this manual.
- The left hand side of mower should be used for trimming.
- Drive so that clippings are discharged onto the area that has been cut. Have the cut area to the right of the tractor. This will result in a more even distribution of clippings and more uniform cutting.
- When mowing large areas, start by turning to the right so that clippings will discharge away from shrubs, fences, driveways, etc. After one or two rounds, mow in the opposite direction making left hand turns until finished.
- If grass is extremely tall, it should be mowed twice to reduce load and possible fire hazard from dried clippings. Make first cut relatively high; the second to the desired height.
- Do not mow grass when it is wet. Wet grass will plug mower and leave undesirable clumps. Allow grass to dry before mowing.
- **Always operate engine at full throttle when mowing** to assure better mowing performance and proper discharge of material. Regulate ground speed by selecting a low enough gear to give the mower cutting performance as well as the quality of cut desired.
- When operating attachments, select a ground speed that will suit the terrain and give best performance of the attachment being used.

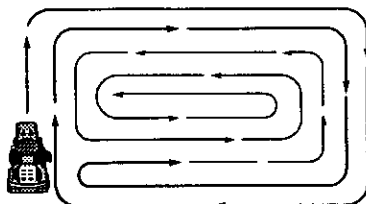

MAINTENANCE

MAINTENANCE SCHEDULE		BEFORE EACH USE EVERY 8 HOURS EVERY 25 HOURS EVERY 50 HOURS EVERY 100 HOURS EVERY SEASON BEFORE STORAGE						SERVICE DATES	
FILL IN DATES AS YOU COMPLETE REGULAR SERVICE									
T R A C T O R	Check Brake Operation	✓	✓						
	Check Tire Pressure	✓	✓						
	Check Operator Presence and Interlock Systems	✓							
	Check for Loose Fasteners	✓				✓ ₇		✓	
	Sharpen/Replace Mower Blades			✓ ₄					
	Lubrication Chart			✓ ₄				✓	
	Check Battery Level			✓ ₅					
	Clean Battery and Terminals			✓				✓	
	Check Transaxle Cooling			✓					
	Adjust Blade Belt(s) Tension					✓ ₅			
Adjust Motion Drive Belt(s) Tension					✓ ₅				
E N G I N E	Check Engine Oil Level	✓	✓						
	Change Engine Oil			✓ _{1,2,3}				✓	
	Clean Air Filter			✓ ₂					
	Clean Air Screen			✓ ₂					
	Inspect Muffler/Spark Arrester				✓				
	Replace Oil Filter (if equipped)					✓ _{1,2}			
	Clean Engine Cooling Fins					✓ ₂			
	Replace Spark Plug					✓	✓		
	Replace Air Filter Paper Cartridge					✓ ₂			
Replace Fuel Filter						✓			

- 1 - Change more often when operating under a heavy load or in high ambient temperatures.
 2 - Service more often when operating in dirty or dusty conditions.
 3 - If equipped with oil filter, change oil every 50 hours.
 4 - Replace blades more often when mowing in sandy soil.
 5 - If equipped with adjustable system.
 6 - Not required if equipped with maintenance-free battery.
 7 - Tighten front axle pivot bolt to 35 ft.-lbs. maximum. Do not overtighten.

GENERAL RECOMMENDATIONS

The warranty on this tractor does not cover items that have been subjected to operator abuse or negligence. To receive full value from the warranty, operator must maintain tractor as instructed in this manual. Some adjustments will need to be made periodically to properly maintain your tractor.

All adjustments in the Service and Adjustments section of this manual should be checked at least once each season.

- Once a year you should replace the spark plug, clean or replace air filter, and check blades and belts for wear. A new spark plug and clean air filter assure proper air-fuel mixture and help your engine run better and last longer.

BEFORE EACH USE

- Check engine oil level.
- Check brake operation.
- Check tire pressure.
- Check operator presence and interlock systems for proper operation.
- Check for loose fasteners.

LUBRICATION CHART

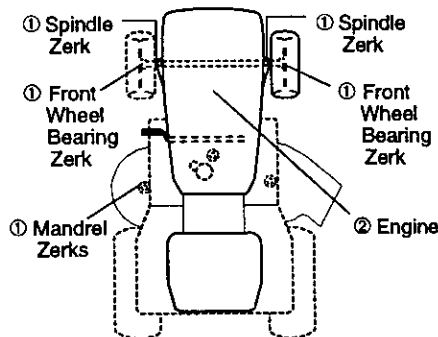

- General Purpose Grease
- Refer to Maintenance "ENGINE" Section

IMPORTANT: Do not oil or grease the pivot points which have special nylon bearings. Viscous lubricants will attract dust and dirt that will shorten the life of the self-lubricating bearings. If you feel they must be lubricated, use only a dry, powdered graphite type lubricant sparingly.

TRACTOR

Always observe safety rules when performing any maintenance.

BRAKE OPERATION

If tractor requires more than six (6) feet stopping distance at high speed in highest gear, then brake must be adjusted. (See "TO ADJUST BRAKE" in the Service and Adjustments section of this manual).

TIRES

- Maintain proper air pressure in all tires (See "PRODUCT SPECIFICATIONS" section of this manual).
- Keep tires free of gasoline, oil, or insect control chemicals which can harm rubber.
- Avoid stumps, stones, deep ruts, sharp objects and other hazards that may cause tire damage.

NOTE: To seal tire punctures and prevent flat tires due to slow leaks, tire sealant may be purchased from your local parts dealer. Tire sealant also prevents tire dry rot and corrosion.

OPERATOR PRESENCE SYSTEM

Be sure that operator presence and interlock systems are working properly. If your tractor does not function as described below, repair the problem immediately.

- The engine should not start unless the brake pedal is fully depressed and attachment clutch control is in the disengaged position.
- When the engine is running, any attempt by the operator to leave the seat without first setting the parking brake should shut off the engine.
- When the engine is running and the attachment clutch is engaged, any attempt by the operator to leave the seat should shut off the engine.
- The attachment clutch should never operate unless the operator is in the seat.

BLADE CARE

For best results mower blades must be kept sharp. Replace bent or damaged blades.

BLADE REMOVAL

1. Raise mower to highest position to allow access to blades.
2. Remove hex bolt, lock washer and flat washer securing blade.
3. Install new or resharpened blade with trailing edge up towards deck as shown.

IMPORTANT: To ensure proper assembly, center hole in blade must align with star on mandrel assembly.

4. Reassemble hex bolt, lock washer and flat washer in exact order as shown.
5. Tighten bolt securely (45-55 Ft. Lbs. torque).

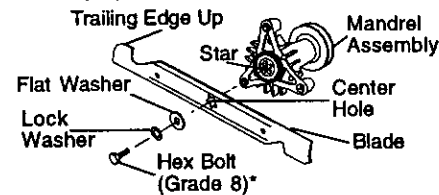

*A Grade 8 heat treated bolt can be identified by six lines on the bolt head.

IMPORTANT: Blade bolt is grade 8 heat treated.

TO SHARPEN BLADE

NOTE: We do not recommend sharpening blade - but if you do, be sure the blade is balanced.

Care should be taken to keep the blade balanced. An unbalanced blade will cause excessive vibration and eventual damage to mower and engine.

- The blade can be sharpened with a file or on a grinding wheel. Do not attempt to sharpen while on the mower.
- To check blade balance, you will need a 5/8" diameter steel bolt, pin, or a cone balancer. (When using a cone balancer, follow the instructions supplied with balancer.)

NOTE: Do not use a nail for balancing blade. The lobes of the center hole may appear to be centered, but are not.

- Slide blade on to an unthreaded portion of the steel bolt or pin and hold the bolt or pin parallel with the ground. If blade is balanced, it should remain in a horizontal position. If either end of the blade moves downward, sharpen the heavy end until the blade is balanced.

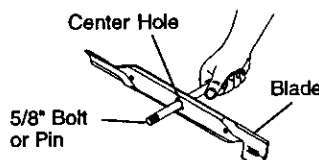

BATTERY

Your tractor has a battery charging system which is sufficient for normal use. However, periodic charging of the battery with an automotive charger will extend its life.

- Keep battery and terminals clean.
- Keep battery bolts tight.
- Keep small vent holes open.
- Recharge at 6-10 amperes for 1 hour.

NOTE: The original equipment battery on your tractor is maintenance free. Do not attempt to open or remove caps or covers. Adding or checking level of electrolyte is not necessary.

TO CLEAN BATTERY AND TERMINALS

Corrosion and dirt on the battery and terminals can cause the battery to "leak" power.

1. Remove terminal guard.
2. Disconnect **BLACK** battery cable first then **RED** battery cable and remove battery from tractor.
3. Rinse the battery with plain water and dry.
4. Clean terminals and battery cable ends with wire brush until bright.
5. Coat terminals with grease or petroleum jelly.
6. Reinstall battery (See "REPLACING BATTERY" in the SERVICE AND ADJUSTMENTS section of this manual).

V-BELTS

Check V-belts for deterioration and wear after 100 hours of operation and replace if necessary. The belts are not adjustable. Replace belts if they begin to slip from wear.

TRANSAXLE COOLING

The transmission fan and cooling fins should be kept clean to assure proper cooling.

Do not attempt to clean fan or transmission while engine is running or while the transmission is hot. To prevent possible damage to seals, do not use high pressure water or steam to clean transaxle.

- Inspect cooling fan to be sure fan blades are intact and clean.
- Inspect cooling fins for dirt, grass clippings and other materials. To prevent damage to seals, do not use compressed air or high pressure sprayer to clean cooling fins.

TRANSAXLE PUMP FLUID

The transaxle was sealed at the factory and fluid maintenance is not required for the life of the transaxle. Should the transaxle ever leak or require servicing, contact your nearest authorized service center/department.

ENGINE LUBRICATION

Only use high quality detergent oil rated with API service classification SF-SJ. Select the oil's SAE viscosity grade according to your expected operating temperature.

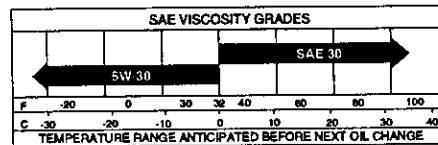

NOTE: Although multi-viscosity oils (5W30, 10W30 etc.) improve starting in cold weather, these multi-viscosity oils will result in increased oil consumption when used above 32°F. Check your engine oil level more frequently to avoid possible engine damage from running low on oil.

Change the oil after every 50 hours of operation or at least once a year if the tractor is not used for 50 hours in one year.

Check the crankcase oil level before starting the engine and after each eight (8) hours of operation. Tighten oil fill cap/dipstick securely each time you check the oil level.

TO CHANGE ENGINE OIL

Determine temperature range expected before oil change. All oil must meet API service classification SF-SJ.

- Be sure tractor is on level surface.
 - Oil will drain more freely when warm.
 - Catch oil in a suitable container.
1. Remove oil fill cap/dipstick. Be careful not to allow dirt to enter the engine when changing oil.
 2. Remove cap from end of drain valve and install the drain tube onto the fitting.
 3. Unlock drain valve by pushing inward slightly and turning counterclockwise.
 4. To open, pull out on the drain valve.
 5. After oil has drained completely, close and lock the drain valve by pushing inward and turning clockwise until the pin is in the locked position as shown.

6. Remove the drain tube and replace the cap onto to the end of the drain valve.
7. Refill engine with oil through oil fill dipstick tube. Pour slowly. Do not overfill. For approximate capacity see "PRODUCT SPECIFICATIONS" section of this manual.
8. Use gauge on oil fill cap/dipstick for checking level. Be sure dipstick cap is tightened securely for accurate reading. Keep oil at "FULL" line on dipstick.

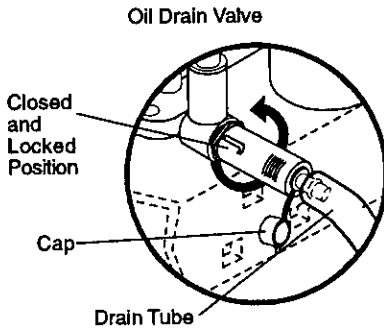

CLEAN AIR SCREEN

Air screen must be kept free of dirt and chaff to prevent engine damage from overheating. Clean with a wire brush or compressed air to remove dirt and stubborn dried gum fibers.

CLEAN AIR INTAKE/COOLING AREAS

To insure proper cooling, make sure the grass screen, cooling fins, and other external surfaces of the engine are kept clean at all times.

Every 100 hours of operation (more often under extremely dusty, dirty conditions), remove the blower housing and other cooling shrouds. Clean the cooling fins and external surfaces as necessary. Make sure the cooling shrouds are reinstalled.

NOTE: Operating the engine with a blocked grass screen, dirty or plugged cooling fins, and/or cooling shrouds removed will cause engine damage due to overheating.

AIR FILTER

Your engine will not run properly using a dirty air filter. Clean the foam pre-cleaner after every 25 hours of operation or every season. Service paper cartridge every 100 hours of operation or every season, whichever occurs first.

Service air cleaner more often under dusty conditions.

1. Remove knobs and cover.

TO SERVICE PRE-CLEANER

2. Wash it in liquid detergent and water.
3. Squeeze it dry in a clean cloth.
4. Saturate it in engine oil. Wrap it in clean, absorbent cloth and squeeze to remove excess oil.

NOTE: If very dirty or damaged, replace pre-cleaner.

TO SERVICE CARTRIDGE

5. Clean cartridge by tapping gently on flat surface. If very dirty or damaged, replace cartridge.
6. Reinstall precleaner cartridge, cover and secure with knobs.

IMPORTANT: Petroleum solvents, such as kerosene, are not to be used to clean the cartridge. They may cause deterioration of the cartridge. Do not oil cartridge. Do not use pressurized air to clean or dry cartridge.

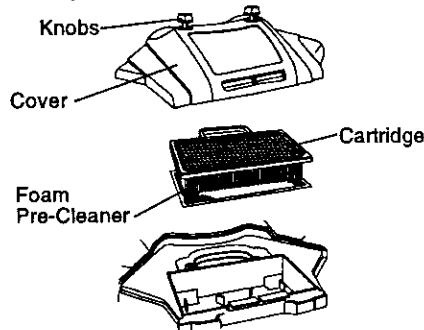

ENGINE OIL FILTER

Replace the engine oil filter every season or every other oil change if the tractor is used more than 100 hours in one year.

MUFFLER

Inspect and replace corroded muffler and spark arrester (if equipped) as it could create a fire hazard and/or damage.

SPARK PLUGS

Replace spark plugs at the beginning of each mowing season or after every 100 hours of operation, whichever occurs first. Spark plug type and gap setting are shown in "PRODUCT SPECIFICATIONS" section of this manual.

IN-LINE FUEL FILTER

The fuel filter should be replaced once each season. If fuel filter becomes clogged, obstructing fuel flow to carburetor, replacement is required.

1. With engine cool, remove filter and plug fuel line sections.
2. Place new fuel filter in position in fuel line with arrow pointing towards carburetor.
3. Be sure there are no fuel line leaks and clamps are properly positioned.
4. Immediately wipe up any spilled gasoline.

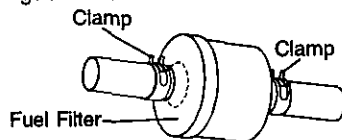

CLEANING

- Clean engine, battery, seat, finish, etc. of all foreign matter.
- Keep finished surfaces and wheels free of all gasoline, oil, etc.
- Protect painted surfaces with automotive type wax.

We do not recommend using a garden hose to clean your tractor unless the electrical system, muffler, air filter and carburetor are covered to keep water out. Water in engine can result in a shortened engine life.

SERVICE AND ADJUSTMENTS



CAUTION: BEFORE PERFORMING ANY SERVICE OR ADJUSTMENTS:

1. Depress brake pedal fully and set parking brake.
2. Place attachment clutch in "DISENGAGED" position.
3. Turn ignition key "OFF" and remove key.
4. Make sure the blades and all moving parts have completely stopped.
5. Disconnect spark plug wire from spark plug and place wire where it cannot come in contact with plug.

TRACTOR

TO REMOVE MOWER

1. Place attachment clutch in "DISENGAGED" position.
2. If equipped, turn height adjustment knob to lowest setting.
3. Lower mower to its lowest position.
4. Disengage belt tension rod from lock bracket.

CAUTION: Rod is spring loaded. Have a tight grip on rod and release slowly.

5. Remove retainer spring holding anti-swaybar to chassis bracket and disengage anti-swaybar from bracket.
6. Remove four retainer springs from front plate assembly and remove plate.

7. Remove retainer springs from suspension arms at deck and disengage arms from deck.
8. Raise attachment lift to its highest position.
9. Slide mower forward and remove belt from electric clutch pulley.
10. Slide mower out from under right side of tractor.

TO INSTALL MOWER

Follow procedure described in "INSTALL MOWER AND DRIVE BELT" in the Assembly section of this manual.

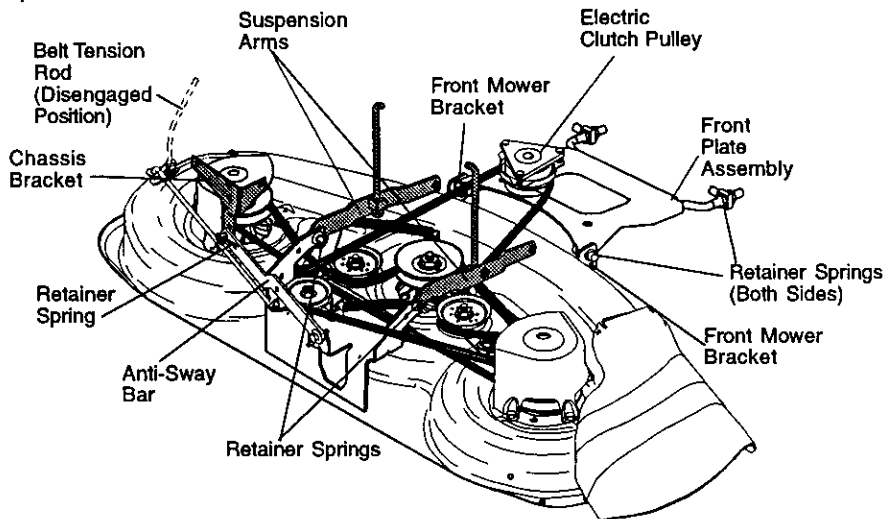

TO LEVEL MOWER HOUSING

Adjust the mower while tractor is parked on level ground or driveway. Make sure tires are properly inflated (See "PRODUCT SPECIFICATIONS" section of this manual). If tires are over or underinflated, you will not properly adjust your mower.

SIDE-TO-SIDE ADJUSTMENT

- Raise mower to its highest position.
- At the midpoint of both sides of mower, measure height from bottom edge of mower to ground. Distance "A" on both sides of mower should be the same or within 1/4" of each other.
- If adjustment is necessary, make adjustment on one side of mower only.
- To raise one side of mower, tighten lift link adjustment nut on that side.
- To lower one side of mower, loosen lift link adjustment nut on that side.

NOTE: Each full turn of adjustment nut will change mower height about 1/8".

- Recheck measurements after adjusting.

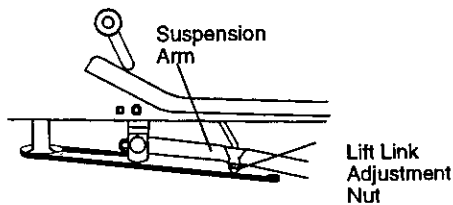
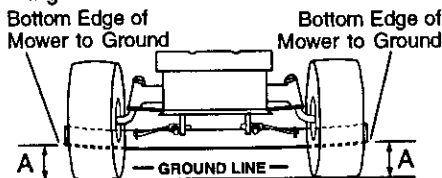

FRONT-TO-BACK ADJUSTMENT

IMPORTANT: Deck must be level side-to-side. If the following front-to-back adjustment is necessary, be sure to adjust both front links equally so mower will stay level side-to-side.

To obtain the best cutting results, the mower housing should be adjusted so that the front is approximately 1/8" to 1/2" lower than the rear when the mower is in its highest position.

Check adjustment on right side of tractor. Measure distance "D" directly in front and behind the mandrel at bottom edge of mower housing as shown.

- Before making any necessary adjustments, check that both front links are equal in length.
- If links are not equal in length, adjust one link to same length as other link.
- To lower front of mower loosen nut "E" on both front links an equal number of turns.
- When distance "D" is 1/8" to 1/2" lower at front than rear, tighten nuts "F" against trunnion on both front links.
- To raise front of mower, loosen nut "F" from trunnion on both front links. Tighten nut "E" on both front links an equal number of turns.
- When distance "D" is 1/8" to 1/2" lower at front than rear, tighten nut "F" against trunnion on both front links.
- Recheck side-to-side adjustment.

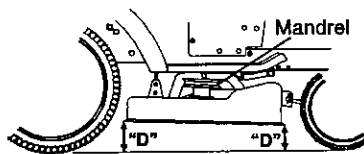

BOTH FRONT LINKS MUST BE EQUAL IN LENGTH

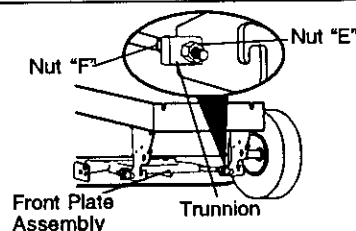
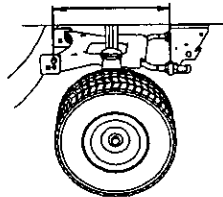

TO REPLACE MOWER DRIVE BELT

MOWER DRIVE BELT REMOVAL

1. Park tractor on a level surface. Engage parking brake.
2. Lower mower to its lowest position.
3. Disengage belt tension rod from lock bracket.

CAUTION: Rod is spring loaded. Have a firm grip on rod and release slowly.

4. Remove screws from R.H. mandrel cover and remove cover.

5. Remove any dirt or grass clippings which may have accumulated around mandrels and entire upper deck surface.
6. Disconnect R.H. suspension arm from rear deck bracket by removing retainer spring.
7. Carefully roll belt over the top of R.H. mandrel pulley.
8. Remove belt from electric clutch pulley.
9. Remove belt from idler pulleys.
10. Check primary idler arm and two idlers to see that they rotate freely.
11. Be sure spring is securely hooked to primary idler arm and spring arm.

MOWER DRIVE BELT INSTALLATION

12. Install belt in both idlers.
13. Install new belt onto electric clutch pulley.
14. Carefully roll belt into upper groove of R.H. mandrel pulley.
15. Carefully check belt routing making sure belt is in the grooves correctly.
16. Reconnect R.H. suspension arm to rear deck bracket with retainer spring.
17. Reassemble R.H. mandrel cover.
18. Engage belt tension rod by pushing rod into locking bracket.

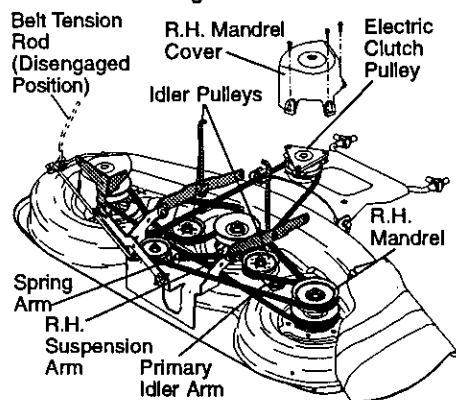

TO REPLACE MOWER BLADE DRIVE BELT

Park the tractor on level surface. Engage parking brake.

1. Remove mower drive belt (See "TO REPLACE MOWER DRIVE BELT" in this section of this manual).
2. Remove mower (See "TO REMOVE MOWER" in this section of this manual).
3. Remove screws from L.H. mandrel cover and remove cover.

4. Carefully roll belt off L.H. mandrel pulley.
5. Remove belt from center mandrel pulley, idler pulley, and R.H. mandrel pulley.
6. Remove any dirt or grass which may have accumulated around mandrels and entire upper deck surface.
7. Check secondary idler arm and idler pulley to see that they rotate freely.
8. Be sure spring is hooked in secondary idler arm and secondary spring arm.
9. Install new belt in lower groove of R.H. mandrel pulley, idler pulley, and center mandrel pulley as shown.
10. Carefully roll belt over L.H. mandrel pulley. Make sure belt is in all grooves properly.
11. Reinstall L.H. mandrel cover.
12. Reinstall mower to tractor (See "INSTALL MOWER AND DRIVE BELT" in the Assembly section of this manual).
13. Reassemble mower drive belt (See "TO REPLACE MOWER DRIVE BELT" in this section of this manual).

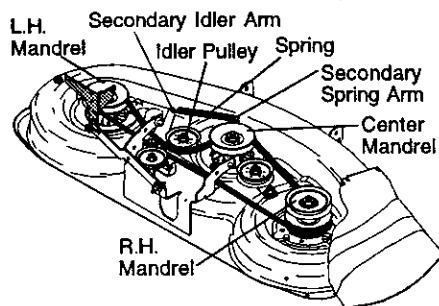

TO ADJUST BRAKE

Your tractor is equipped with an adjustable brake system which is mounted on the side of the transaxle.

If tractor requires more than six (6) feet stopping distance at high speed in highest gear on a level dry concrete or paved surface, then brake must be adjusted.

1. Depress clutch/brake pedal and engage parking brake.
2. Measure distance between brake operating arm and nut "A" on brake rod.
3. If distance is other than 1-11/16", loosen jam nut and turn nut "A" until distance becomes 1-11/16". Re-tighten jam nut against nut "A".

- Road test tractor for proper stopping distance as stated above. Readjust if necessary. If stopping distance is still greater than six (6) feet in highest gear, further maintenance is necessary. Contact a Sears or other qualified service center.

With Parking Brake "Engaged"

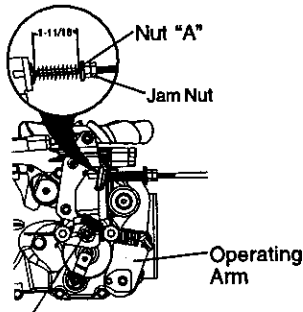

Do Not touch this nut. If further brake adjustment is necessary, contact a Sears or other qualified service center.

TO REPLACE MOTION DRIVE BELT

Park the tractor on level surface. Engage parking brake. For assistance, there is a belt installation guide decal on bottom side of left footrest.

- Remove mower (See "TO REMOVE MOWER" in this section of this manual.)
- Disconnect clutch wire harness.
- Remove clutch locator.
- Remove belt from stationary idler and clutching idler.
- Pull belt slack toward rear of tractor. Carefully remove belt upwards from transmission input pulley and over cooling fan blades.
- Pull belt toward front of tractor and remove downwards from around electric clutch.
- Install new belt by reversing above procedure.

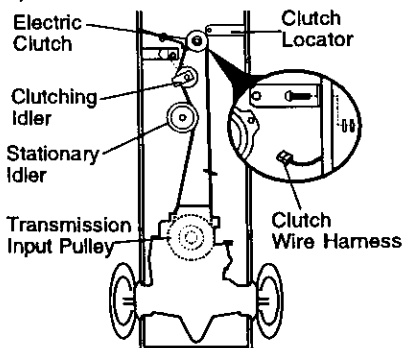

TRANSMISSION REMOVAL/REPLACEMENT

Should your transmission require removal for service or replacement, it should be purged after reinstallation and before operating the tractor. See "PURGE TRANSMISSION" in the Operation section of this manual.

TO ADJUST STEERING WHEEL ALIGNMENT

If steering wheel crossbars are not horizontal (left to right) when wheels are positioned straight forward, remove steering wheel and reassemble per instructions in the Assembly section of this manual.

FRONT WHEEL TOE-IN/CAMBER

The front wheel toe-in and camber are not adjustable on your tractor. If damage has occurred to affect the front wheel toe-in or camber, contact your nearest Sears or other qualified service center.

TO REMOVE WHEEL FOR REPAIRS

- Block up axle securely.
- Remove axle cover, retaining ring and washers to allow wheel removal (rear wheel contains a square key - Do not lose).
- Repair tire and reassemble.
NOTE: On rear wheels only: align grooves in rear wheel hub and axle. Insert square key.
- Replace washers and snap retaining ring securely in axle groove.
- Replace axle cover.

NOTE: To seal tire punctures and prevent flat tires due to slow leaks, tire sealant may be purchased from your local parts dealer. Tire sealant also prevents tire dry rot and corrosion.

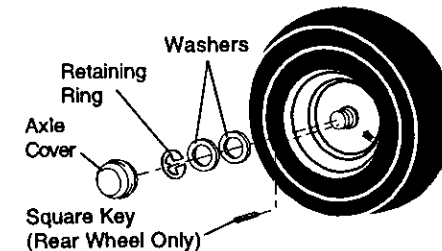

TO START ENGINE WITH A WEAK BATTERY

CAUTION: Lead-acid batteries generate explosive gases. Keep sparks, flame and smoking materials away from batteries. Always wear eye protection when around batteries.

If your battery is too weak to start the engine, it should be recharged. (See "BATTERY" in the MAINTENANCE section of this manual).

If "jumper cables" are used for emergency starting, follow this procedure:

IMPORTANT: Your tractor is equipped with a 12 volt negative grounded system. The other vehical must also be a 12 volt negative grounded system. Do not use your tractor battery to start other vehicles.

TO ATTACH JUMPER CABLES -

1. Connect each end of the RED cable to the POSITIVE (+) terminal of each battery, taking care not to short against chassis.
2. Connect one end of the BLACK cable to the NEGATIVE (-) terminal of fully charged battery.
3. Connect the other end of the BLACK cable to good CHASSIS GROUND, away from fuel tank and battery.

TO REMOVE CABLES, REVERSE ORDER -

1. BLACK cable first from chassis and then from the fully charged battery.
2. RED cable last from both batteries.

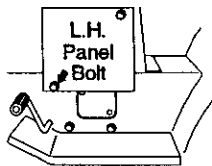
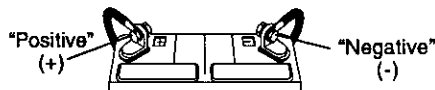

REPLACING BATTERY

CAUTION: Do not short battery terminals by allowing a wrench or any other object to contact both terminals at the same time. Before connecting battery, remove metal bracelets, wristwatch bands, rings, etc.

Positive terminal must be connected first to prevent sparking from accidental grounding.

1. Lift hood to raised position.
2. Remove terminal guard.

3. Disconnect BLACK battery cable then RED battery cable and carefully remove battery from tractor.
4. Install new battery with terminals in same position as old battery.
5. Reinstall terminal guard.
6. First connect RED battery cable to positive (+) battery terminal with hex bolt and keps nut as shown. Tighten securely.
7. Connect BLACK grounding cable to negative (-) battery terminal with remaining hex bolt and keps nut. Tighten securely.
8. Close terminal access doors.
9. Close hood.

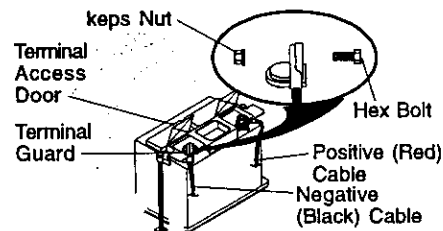

TO REPLACE HEADLIGHT LAMP

CAUTION: When lit, the halogen lamps get extremely hot. Hold lamp assembly by the holder and do not touch the bulb.

1. Raise hood.
2. Disconnect harness from lamp assembly.
3. Rotate counterclockwise and pull lamp assembly out of the hole in the backside of the grill.
4. Insert new lamp assembly and rotate clockwise to lock.
5. Reconnect harness to lamp assembly.
6. Close hood.

INTERLOCKS AND RELAYS

Loose or damaged wiring may cause your tractor to run poorly, stop running, or prevent it from starting.

- Check wiring. See electrical wiring diagram in the Repair Parts section.

TO REPLACE FUSE

Replace with 20 amp automotive-type plug-in fuse. The fuse holder is located behind the dash.

TO REMOVE HOOD AND GRILL ASSEMBLY

1. Raise hood.
2. Unsnap headlight wire connector.
3. Stand in front of tractor. Grasp hood at sides, tilt toward engine and lift off of tractor.
4. To replace, reverse above procedure.

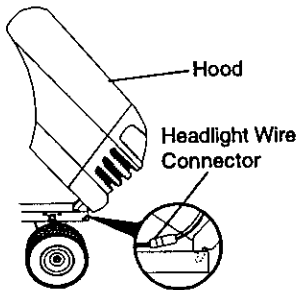

ENGINE

Maintenance, repair, or replacement of the emission control devices and systems, which are being done at the customer's expense, may be performed by any non-road engine repair establishment or individual. Warranty repairs must be performed by an authorized engine manufacturer's service outlet.

TO ADJUST THROTTLE CONTROL CABLE

The throttle control has been preset at the factory and adjustment should not be necessary. Check adjustment as described below before loosening cable. If adjustment is necessary, proceed as follows:

1. With engine not running, move throttle control lever to fast position.
2. Check that swivel is against stop. If it is not, loosen cable clamp screw and pull cable back until swivel is against stop. Tighten cable clamp screw securely.

TO ADJUST CHOKE CONTROL

The choke control has been preset at the factory and adjustment should not be necessary. Check adjustment as described below before loosening cable. If adjustment is necessary, proceed as follows:

1. With engine not running, move choke control (located on dash panel) to full choke position.
2. Loosen knob and remove cover assembly from air cleaner.
3. Choke should be closed. If it is not, loosen casing clamp screw and move choke cable until choke is completely closed. Tighten casing clamp screw securely.
4. Replace air cleaner cover assembly and tighten knob.

TO ADJUST CARBURETOR

Your carburetor is not adjustable. If your engine does not operate properly due to suspected carburetor problems, take your tractor to an authorized service center for repair and/or adjustment.

High speed stop is factory adjusted. Do not adjust - damage may result.

IMPORTANT: Never tamper with the engine governor, which is factory set for proper engine speed. Overspeeding the engine above the factory high speed setting can be dangerous. If you think the engine-governed high speed needs adjusting, contact a Sears or other qualified service center, which has proper equipment and experience to make any necessary adjustments.

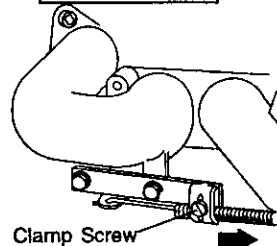
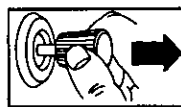
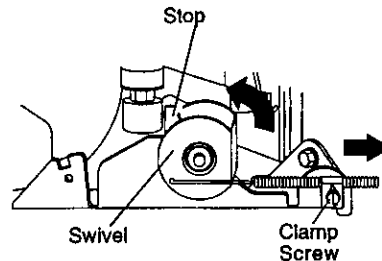

STORAGE

Immediately prepare your tractor for storage at the end of the season or if the tractor will not be used for 30 days or more.

CAUTION: Never store the tractor with gasoline in the tank inside a building where fumes may reach an open flame or spark. Allow the engine to cool before storing in any enclosure.

TRACTOR

Remove mower from tractor for winter storage. When mower is to be stored for a period of time, clean it thoroughly, remove all dirt, grease, leaves, etc. Store in a clean, dry area.

1. Clean entire tractor (See "CLEANING" in the Maintenance section of this manual).
2. Inspect and replace belts, if necessary (See belt replacement instructions in the Service and Adjustments section of this manual).
3. Lubricate as shown in the Maintenance section of this manual.
4. Be sure that all nuts, bolts and screws are securely fastened. Inspect moving parts for damage, breakage and wear. Replace if necessary.
5. Touch up all rusted or chipped paint surfaces; sand lightly before painting.

BATTERY

- Fully charge the battery for storage.
- After a period of time in storage, battery may require recharging.
- To help prevent corrosion and power leakage during long periods of storage, battery cables should be disconnected and battery cleaned thoroughly (see "TO CLEAN BATTERY AND TERMINALS" in the Maintenance section of this manual).
- After cleaning, leave cables disconnected and place cables where they cannot come in contact with battery terminals.
- If battery is removed from tractor for storage, do not store battery directly on concrete or damp surfaces.

ENGINE

FUEL SYSTEM

IMPORTANT: It is important to prevent gum deposits from forming in essential fuel system parts such as carburetor, fuel hose, or tank during storage. Also,

experience indicates that alcohol blended fuels (called gasohol or using ethanol or methanol) can attract moisture which leads to separation and formation of acids during storage. Acidic gas can damage the fuel system of an engine while in storage.

1. Drain the fuel tank.
2. Start the engine and let it run until the fuel lines and carburetor are empty.
 - Never use engine or carburetor cleaner products in the fuel tank or permanent damage may occur.
 - Use fresh fuel next season.

NOTE: Fuel stabilizer is an acceptable alternative in minimizing the formation of fuel gum deposits during storage. Add stabilizer to gasoline in fuel tank or storage container. Always follow the mix ratio found on stabilizer container. Run engine at least 10 minutes after adding stabilizer to allow the stabilizer to reach the carburetor. Do not drain the gas tank and carburetor if using fuel stabilizer.

ENGINE OIL

Drain oil (with engine warm) and replace with clean engine oil. (See "ENGINE" in the Maintenance section of this manual).

CYLINDER(S)

1. Remove spark plug(s).
2. Pour one ounce of oil through spark plug hole(s) into cylinder(s).
3. Turn ignition key to "START" position for a few seconds to distribute oil.
4. Replace with new spark plug(s).

OTHER

- Do not store gasoline from one season to another.
- Replace your gasoline can if your can starts to rust. Rust and/or dirt in your gasoline will cause problems.
- If possible, store your tractor indoors and cover it to give protection from dust and dirt.
- Cover your tractor with a suitable protective cover that does not retain moisture. Do not use plastic. Plastic cannot breathe which allows condensation to form and will cause your tractor to rust.

IMPORTANT: Never cover tractor while engine and exhaust areas are still warm.

TROUBLESHOOTING CHART

PROBLEM	CAUSE	CORRECTION
Will not start	<ol style="list-style-type: none"> 1. Out of fuel. 2. Engine not "CHOKED" properly. 3. Engine flooded. 4. Bad spark plug. 5. Dirty air filter. 6. Dirty fuel filter. 7. Water in fuel. 8. Loose or damaged wiring. 9. Carburetor out of adjustment. 10. Engine valves out of adjustment. 	<ol style="list-style-type: none"> 1. Fill fuel tank. 2. See "TO START ENGINE" in Operation section. 3. Wait several minutes before attempting to start. 4. Replace spark plug. 5. Clean/replace air filter. 6. Replace fuel filter. 7. Drain fuel tank and carburetor, refill tank with fresh gasoline and replace fuel filter. 8. Check all wiring. 9. See "To Adjust Carburetor" in Service Adjustments section. 10. Contact a Sears or other qualified service center.
Hard to start	<ol style="list-style-type: none"> 1. Dirty air filter. 2. Bad spark plug. 3. Weak or dead battery. 4. Dirty fuel filter. 5. Stale or dirty fuel. 6. Loose or damaged wiring. 7. Carburetor out of adjustment. 8. Engine valves out of adjustment. 	<ol style="list-style-type: none"> 1. Clean/replace air filter. 2. Replace spark plug. 3. Recharge or replace battery. 4. Replace fuel filter. 5. Drain fuel tank and refill with fresh gasoline. 6. Check all wiring. 7. See "To Adjust Carburetor" in Service Adjustments section. 8. Contact a Sears or other qualified service center.
Engine will not turn over	<ol style="list-style-type: none"> 1. Brake pedal not depressed. 2. Attachment clutch is engaged. 3. Weak or dead battery. 4. Blown fuse. 5. Corroded battery terminals. 6. Loose or damaged wiring. 7. Faulty ignition switch. 8. Faulty solenoid or starter. 9. Faulty operator presence switch(es). 	<ol style="list-style-type: none"> 1. Depress brake pedal. 2. Disengage attachment clutch. 3. Recharge or replace battery. 4. Replace fuse. 5. Clean battery terminals. 6. Check all wiring. 7. Check/replace ignition switch. 8. Check/replace solenoid or starter. 9. Contact a Sears or other qualified service center.
Engine clicks but will not start	<ol style="list-style-type: none"> 1. Weak or dead battery. 2. Corroded battery terminals. 3. Loose or damaged wiring. 4. Faulty solenoid or starter. 	<ol style="list-style-type: none"> 1. Recharge or replace battery. 2. Clean battery terminals. 3. Check all wiring. 4. Check/replace solenoid or starter.
Loss of power	<ol style="list-style-type: none"> 1. Cutting too much grass/too fast. 2. Throttle in "CHOKE" position. 	<ol style="list-style-type: none"> 1. Set in "Higher Cut" position/ reduce speed. 2. Adjust throttle control.

TROUBLESHOOTING CHART

PROBLEM	CAUSE	CORRECTION
Loss of power (continued)	<ol style="list-style-type: none"> 3. Build-up of grass, leaves and trash under mower. 4. Dirty air filter. 5. Low oil level/dirty oil. 6. Faulty spark plug. 7. Dirty fuel filter. 8. Stale or dirty fuel. 9. Water in fuel. 10. Spark plug wire loose. 11. Dirty engine air screen/fins. 12. Dirty/clogged muffler. 13. Loose or damaged wiring. 14. Carburetor out of adjustment. 15. Engine valves out of adjustment. 	<ol style="list-style-type: none"> 3. Clean underside of mower housing. 4. Clean/replace air filter. 5. Check oil level/change oil. 6. Clean and regap or change spark plug. 7. Replace fuel filter. 8. Drain fuel tank and refill with fresh gasoline. 9. Drain fuel tank and carburetor, refill tank with fresh gasoline and replace fuel filter. 10. Connect and tighten spark plug wire. 11. Clean engine air screen/fins. 12. Clean/replace muffler. 13. Check all wiring. 14. See "To Adjust Carburetor" in Service Adjustments section. 15. Contact a Sears or other qualified service center.
Excessive vibration	<ol style="list-style-type: none"> 1. Worn, bent or loose blade. 2. Bent blade mandrel. 3. Loose/damaged part(s). 	<ol style="list-style-type: none"> 1. Replace blade. Tighten blade bolt. 2. Replace blade mandrel. 3. Tighten loose part(s). Replace damaged parts.
Engine continues to run when operator leaves seat with attachment clutch engaged	<ol style="list-style-type: none"> 1. Faulty operator-safety presence control system. 	<ol style="list-style-type: none"> 1. Check wiring, switches and connections. If not corrected, contact a Sears or other qualified service center.
Poor cut - uneven	<ol style="list-style-type: none"> 1. Worn, bent or loose blade. 2. Mower deck not level. 3. Buildup of grass, leaves, and trash under mower. 4. Bent blade mandrel. 5. Clogged mower deck vent from build-up of grass, leaves, and trash around mandrels. 	<ol style="list-style-type: none"> 1. Replace blade. Tighten blade bolt. 2. Level mower deck. 3. Clean underside of mower housing. 4. Replace blade mandrel. 5. Clean around mandrels to open vent holes.
Mower blades will not rotate	<ol style="list-style-type: none"> 1. Obstruction in clutch mechanism. 2. Worn/damaged mower drive belt. 3. Frozen idler pulley. 4. Frozen blade mandrel. 	<ol style="list-style-type: none"> 1. Remove obstruction. 2. Replace mower drive belt. 3. Replace idler pulley. 4. Replace blade mandrel.

TROUBLESHOOTING CHART

PROBLEM	CAUSE	CORRECTION
Poor grass discharge	<ol style="list-style-type: none"> 1. Engine speed too slow. 2. Travel speed too fast. 3. Wet grass. 4. Mower deck not level. 5. Low/uneven tire air pressure. 6. Worn, bent or loose blade. 7. Buildup of grass, leaves and trash under mower. 8. Mower drive belt worn. 9. Blades improperly installed. 10. Improper blades used. 11. Clogged mower deck vent holes from buildup of grass, leaves, and trash around mandrels. 	<ol style="list-style-type: none"> 1. Place throttle control in "FAST" position. 2. Shift to slower speed. 3. Allow grass to dry before mowing. 4. Level mower deck. 5. Check tires for proper air pressure. 6. Replace/sharpen blade. Tighten blade bolt. 7. Clean underside of mower housing. 8. Replace mower drive belt. 9. Reinstall blades sharp edge down. 10. Replace with blades listed in this manual. 11. Clean around mandrels to open vent holes.
Headlight(s) not working (if so equipped)	<ol style="list-style-type: none"> 1. Switch is "OFF". 2. Bulb(s) or lamp(s) burned out. 3. Faulty light switch. 4. Loose or damaged wiring. 5. Blown fuse. 	<ol style="list-style-type: none"> 1. Turn switch "ON". 2. Replace bulb(s) or Lamp(s). 3. Check/replace light switch. 4. Check wiring and connections. 5. Replace fuse.
Battery will not charge	<ol style="list-style-type: none"> 1. Bad battery cell(s). 2. Poor cable connections. 3. Faulty regulator (if so equipped). 4. Faulty alternator. 	<ol style="list-style-type: none"> 1. Replace battery. 2. Check/clean all connections. 3. Replace regulator. 4. Replace alternator.
Loss of drive	<ol style="list-style-type: none"> 1. Freewheel control in "disengaged" position. 2. Motion drive belt worn, damaged, or broken. 3. Air trapped in transmission during shipment or servicing. 	<ol style="list-style-type: none"> 1. Place freewheel control in "engaged" position. 2. Replace motion drive belt. 3. Purge transmission.
Engine "backfires" when turning engine "OFF"	<ol style="list-style-type: none"> 1. Engine throttle control not set at "SLOW" position for 30 seconds before stopping engine. 	<ol style="list-style-type: none"> 1. Move throttle control to "SLOW" position and allow to idle for 30 seconds before stopping engine.

TRACTOR -- MODEL NUMBER 917.272262

SCHEMATIC

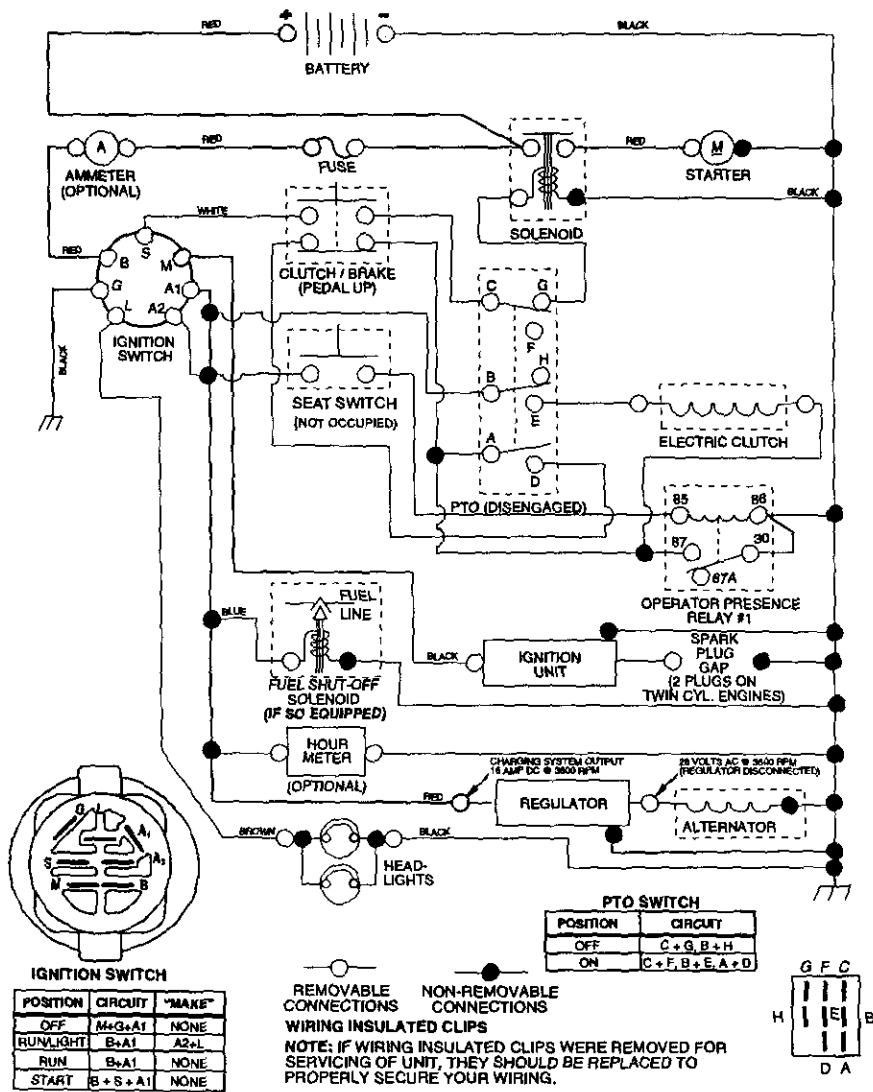

REPAIR PARTS

TRACTOR -- MODEL NUMBER 917.272262

ELECTRICAL

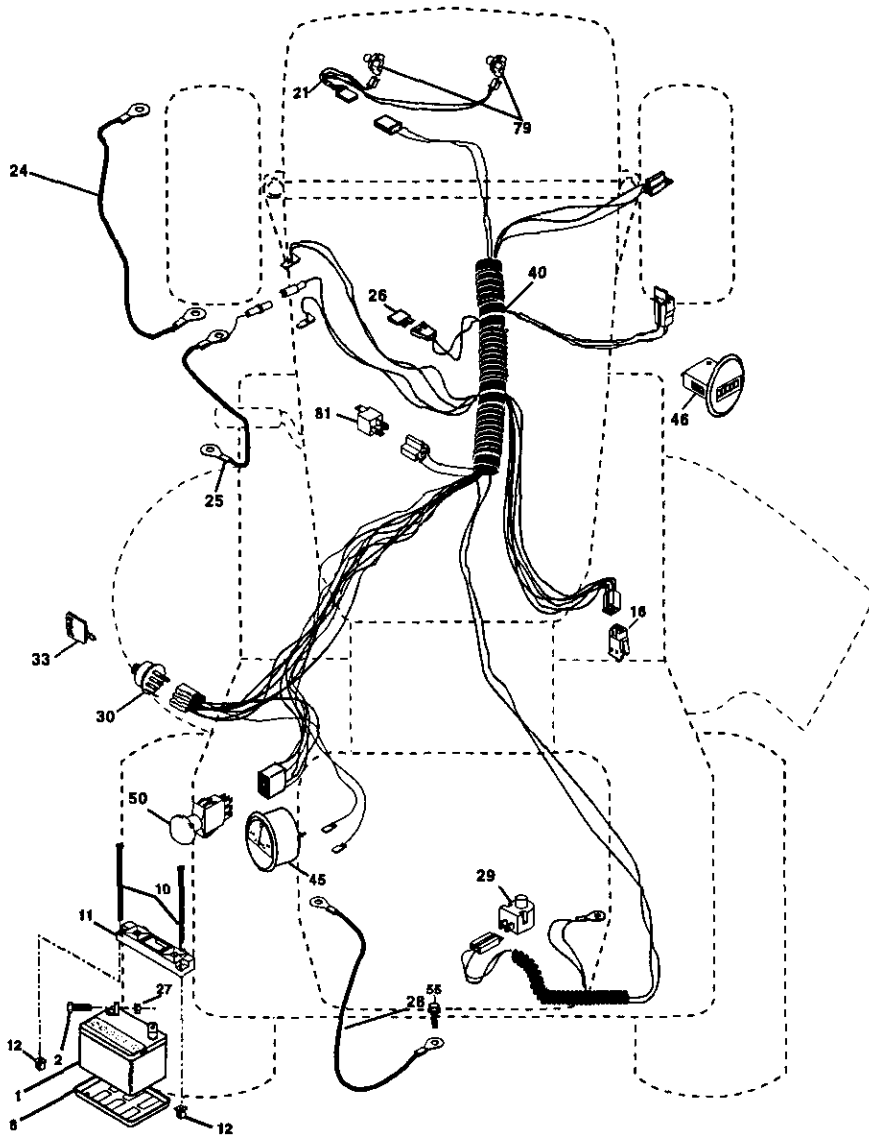

ELECTRICAL

TRACTOR -- MODEL NUMBER 917.272262

KEY PART NO.	PART NO.	DESCRIPTION
1	163465	Battery
2	74760412	Bolt, Hex 1/4-20 x 3/4
8	7603J	Tray, Battery
10	145211	Bolt, Btr Front 1/4-20 x 7-1/2
11	150109	Holddown Battery Front Mount
12	145769	Nut, Push Nylon Battery Front 1/4
16	153664	Switch Interlock Push-In
21	175449	Harness, Light
24	4799J	Cable, Battery
25	146148	Cable, Battery
26	175158	Fuse
27	73510400	Nut Keps Hex 1/4-20 UNC
28	145491	Cable, Ground
29	160784	Switch, Seat
30	175442	Switch, Ignition
33	175447	Key
40	178452	Harness, Ignition
41	71110408	Bolt Fin Hex 1/4-20 Unc x 1/2
42	131563	Cover, Terminal
43	178861	Solenoid
45	175500	Ammeter
46	177501	Hourmeter
50	178461	Switch Pto
55	17490508	Screw Thdrol 5/16-18 x 1/2
79	175448	Lamp and Holder Asm
81	109748X	Relay Asm

NOTE: All component dimensions given in U.S. inches
1 inch = 25.4 mm

TRACTOR -- MODEL NUMBER 917.272262
CHASSIS AND ENCLOSURES

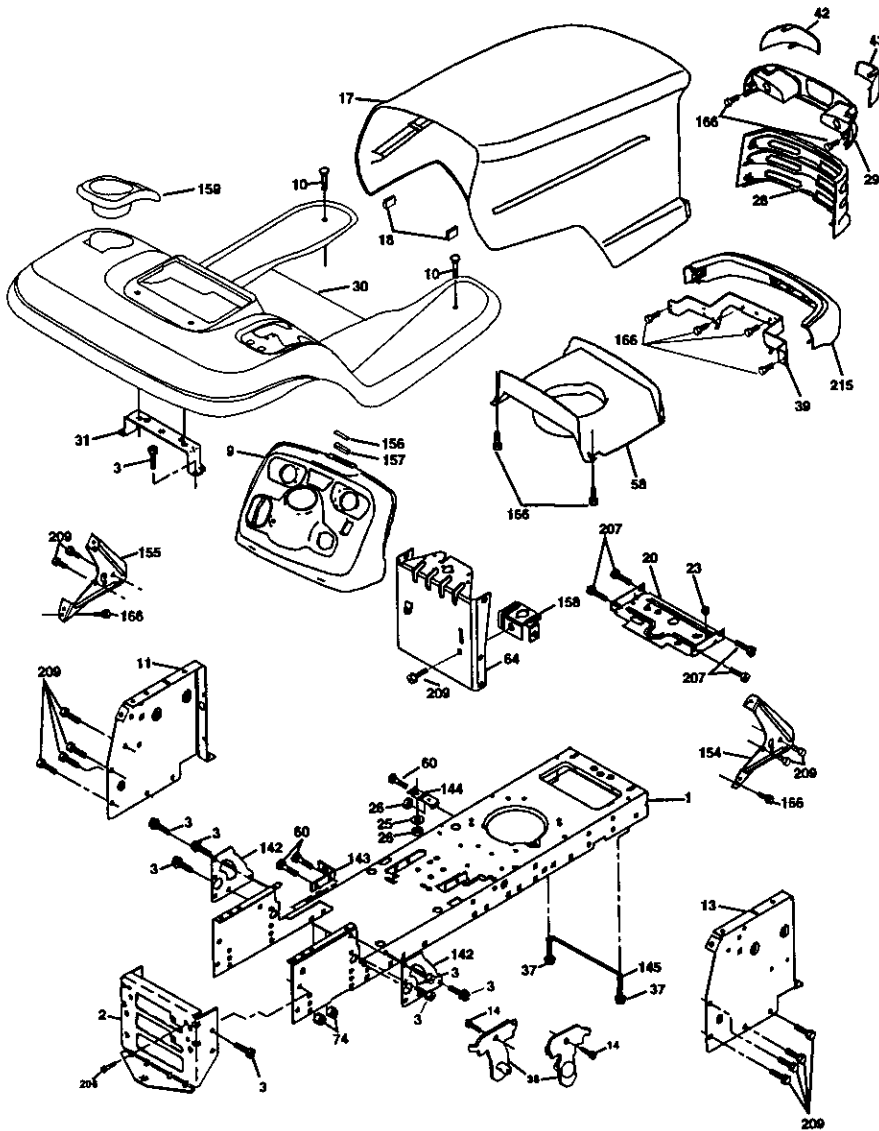

TRACTOR -- MODEL NUMBER 917.272262
CHASSIS AND ENCLOSURES

KEY PART NO.	PART NO.	DESCRIPTION
1	174619	Chassis
2	176554	Drawbar
3	17060612	Screw, 3/8-16 x 3/4
9	172542X418	Dash
11	174996	Panel, Dash, LH
10	72140608	Bolt 3/8-16 x 1
13	179174X010	Panel, Dash, RH
14	17490608	Screw Thdrol 3/8-16 x 1/2
17	172540X615	Hood Assembly
18	126936X	Bumper Hood
20	156437	Plate Battery
23	124028X	Bushing Snap
25	19131312	Washer 13/32 x 13/16 x 12 Gauge
26	STD541437	Locknut, Hex, with Insert 3/8-16 UNC
28	174945X418	Grille
29	174944X418	Lightbox Dual
30	175692X615	Fender/Footrest
31	139976	Bracket, Fender/Support
37	17490508	Screw, Thdrol. 5/16-18 x 1/2 TYT
38	175710	Bracket Asm Pivot Mower Rear
39	174988	Bracket Pivot Hood
42	172545X599	Lens Lh
43	172544X599	Lens Rh
58	174993	Duct Hood
60	STD533707	Bolt Rdhd Sqnk 3/8-16 UNC x 3/4
64	174997	Dash Lower
74	STD541437	Nut Crownlock 3/8-16 UNC
142	175702	Plate Reinforcement
143	154966	Bracket Swaybar Chassis
144	175582	Bracket Footrest
145	156524	Rod Pivot Chassis/Hood
154	174879	Bracket Dash Rh
155	174680	Bracket Dash Lh
156	163805	Striker Plate
157	163806	Magnet YTGT
158	162037	Parking Brake Bkrt
159	155123X418	Cupholder Stl Bk
166	164863	HWHDH:-Lo. #13-16 x 3/4
206	170165	Bolt Shoulder 5/16-18
207	17670508	Screw Thdrol 5/16-18 x 1/2
209	17000612	Screw Hexwsh Thdr 3/8-16 x 3/4
215	172543X615	Bumper

NOTE: All component dimensions given in U.S. inches
1 inch = 25.4 mm

TRACTOR -- MODEL NUMBER 917.272262
GROUND DRIVE

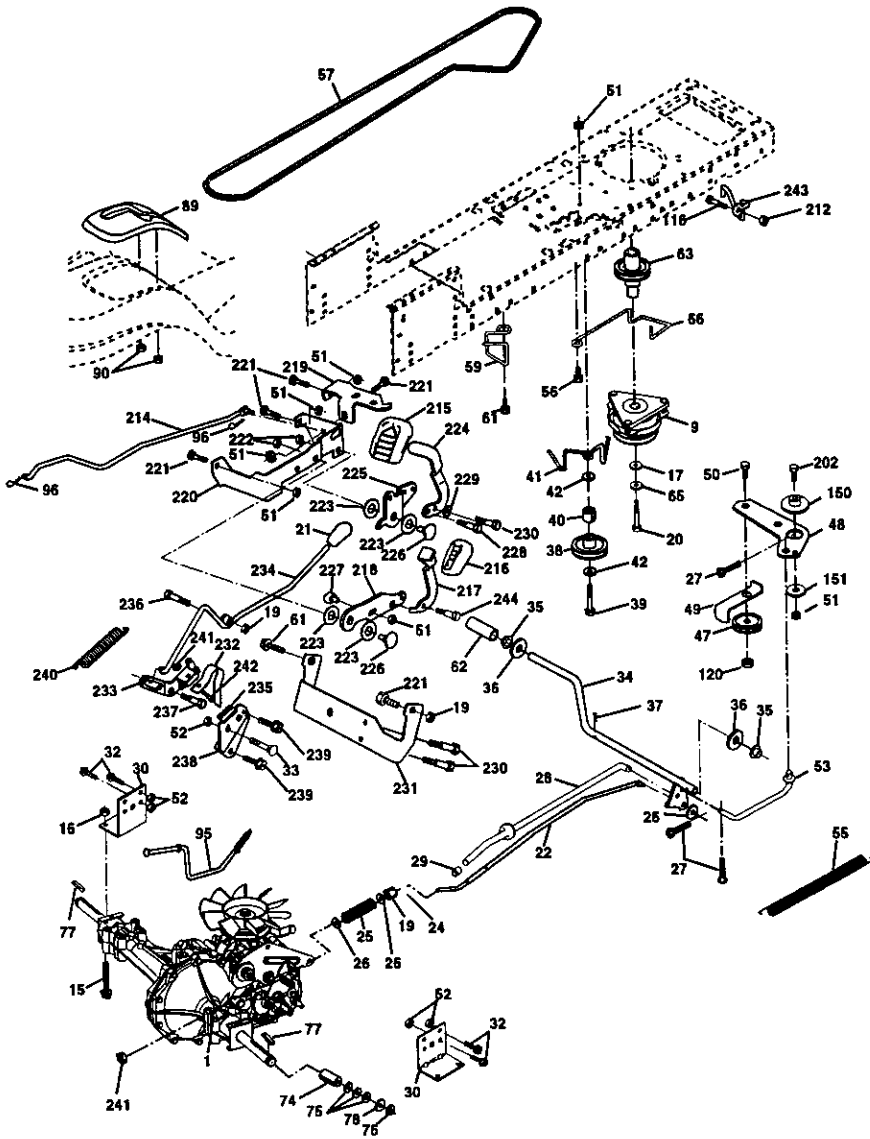

TRACTOR -- MODEL NUMBER 917.272262

GROUND DRIVE

KEY PART NO.	NO.	DESCRIPTION	KEY PART NO.	NO.	DESCRIPTION
1	-----	Transaxle (See Breakdown)	76	12000001	E-Ring
		Hydro gear Model 323-0510	77	123583X	Key, Square
9	174367	Clutch Elec	78	121748X	Washer 25/32 x 1-5/8 x 16 Ga.
15	74490544	Bolt Hex Flghd 5/16-18 Gr. 5	89	174901X418	Console, Shift
16	73800500	Nut Lock Hex W/Ina. 5/16-18 Unc	90	124346X	Nut Self-Thd Wsh-hd 1/4 Zinc
17	126197X	Washer 1-1/2 OD x 15/32 ID x .250	95	175899	Rod Bypass
			96	4497H	Retainer Spring 1" Zinc/Cad
19	73800600	Nut Lock Hex W/Wsh 3/8-16 Unc	116	72140608	Bolt RDHD SQNK 3/8-16 Unc x 1
20	173937	Bolt Hex 7/16-20 x 4 x Gr. 5-1.5	120	73900600	Nut Lock Fig 3/8-16 Unc
21	175036X505	Knob Custom Control Cruise	150	175456	Spacer Retainer
22	175896	Rod, Brake	151	19133210	Washer 13/32 x 2 x 10 Ga.
24	73350600	Nut, Hex Jam 3/8-16 Unc	202	72110612	Bolt Carr Sh 3/8-16 x 1-1/2 Gr. 5
25	106888X	Spring, Brake Rod	212	145212	Nut Hex Flange Lock
26	19131316	Washer	214	174735	Link Transaxle
27	76020412	Pin Cotter 1/8 x 3/4 CAD.	215	175646	Cover Pedal Forward
28	175798	Rod, Parking Brake	216	175647	Cover Pedal Reverse
29	175799X505	Knob Brake Parking	217	174737	Pedal Reverse
30	169592	Bracket, Transaxle	218	174713	Arm Control Pedal Reverse
32	74760512	Bolt Hex Hd 5/16-18 Unc x 3/4	219	174839	Bracket Frest Pdl Ctr. Hyd
33	72140506	Bolt Rdhd Sqnk 5/16-18 Unc x 3/4	220	174711	Bracket Mtg. Pedal Control
34	175578	Shaft, Foot Pedal	221	72140606	Bolt Rdhd Sqnk 3/8-16 Unc x 3/4
35	120183X	Bearing, Nylon	222	73680700	Nut Crownlock 7/16-14 Unc
36	19211616	Washer	223	174840	Washer Nylon 1 1/16 ID x .060
37	1572H	Pin, Roll	224	174736	Pedal Forward
38	165936	Pulley, Composite, Flat	225	174712	Arm Control Pedal Forward
39	74780648	Bolt Fin Hex 3/8-16 Unc x 3	226	174902	Bolt Pivot Spacer
40	175461	Spacer, Split	227	174710	Cam Reverse Pedal LT
41	175556	Keeper, Belt Idler Flat	228	171873	Bolt Shoulder 5/16-18
42	19131312	Washer 13/32 x 13/16 x 12 Ga.	229	176451	Washer Serrated 5/16 x .75
47	127783	Pulley, Idler, V-Groove	230	17060512	Screw 5/16-18
48	154407	Bellcrank Clutch Grnd Drw Sti	231	174573	Strap Torque
49	123205X	Retainer, Belt	232	175570	Actuator Cruise Disengage
50	74760624	Bolt	233	174856	Pawl Control Cruise
51	73680600	Nut Crownlock 3/8-16 UNC	234	174858	Lever Control Cruise
52	73680500	Nut, Crownlock 5/16-18 Unc	235	174857	Sector Control Cruise
53	105710X	Link, Clutch	236	128903	Bolt Shoulder 3/8-16 Unc 1/44
55	105709X	Spring, Return, Clutch	237	170165	Bolt Shoulder 5/16-18
56	17060616	Screw 3/8-16 x 1.0	238	175807	Arm Mtg. Cruise Sector
57	140294	V-Belt, Ground Drive	239	17490508	Screw Thdrol 5/16 x 1/2
59	169691	Keeper, Center Span	240	175610	Spring Return Cruise Control
61	17060612	Screw 3/8-16 x 3/4	241	73930400	Nut Centerlock 1/4-20 Unc
62	123533X	Cover, Pedal	242	74780412	Bolt Fin Hex 1/4-20 Unc x 3/4
63	175417	Pulley, Engine	243	178289	Bracket Anti-Rotation CVX
65	10040700	Washer	244	17060508	Screw 5/16-18 x 1/2
66	154778	Keeper Belt Engine			
74	137057	Spacer, Axle			
75	121749X	Washer 25/32 x 1-1/4 x 16 Ga.			

NOTE: All component dimensions given in U.S. Inches
1 inch = 25.4 mm

TRACTOR -- MODEL NUMBER 917.272262
STEERING ASSEMBLY

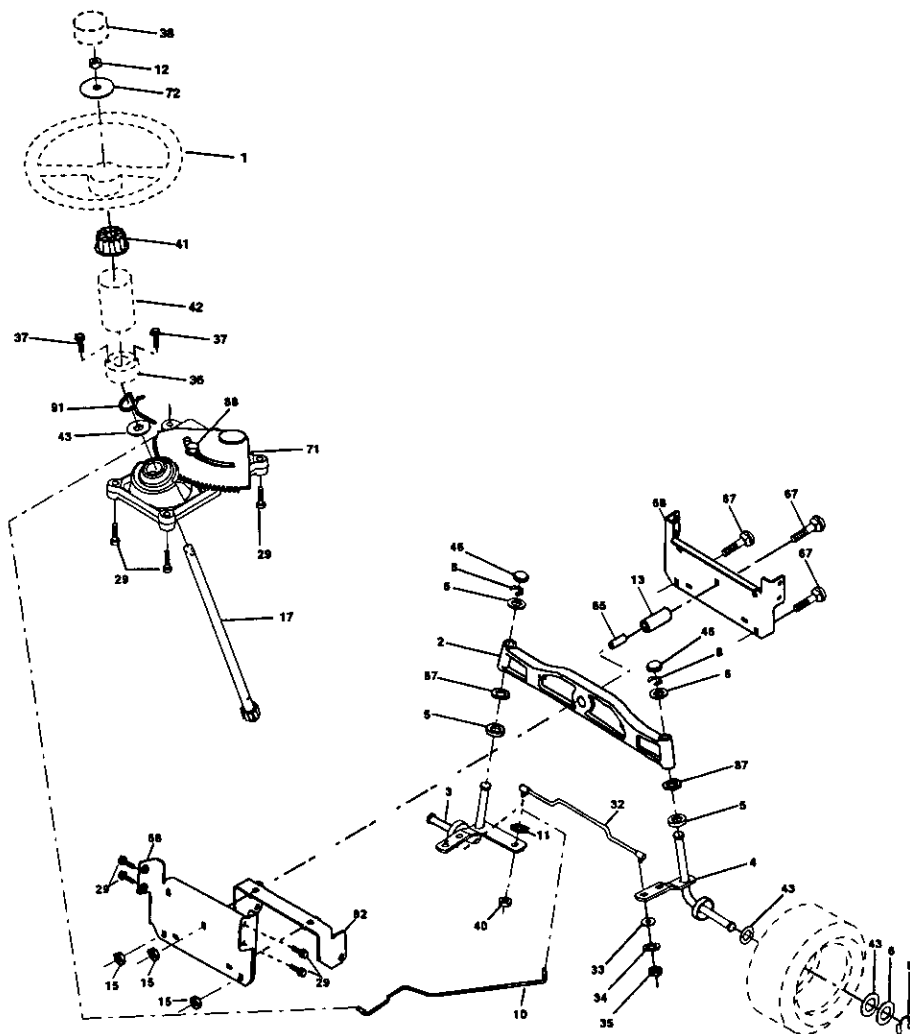

TRACTOR -- MODEL NUMBER 917.272262
STEERING ASSEMBLY

KEY PART NO.	NO.	DESCRIPTION
1	175139X418	Steering Wheel
2	172393	Axle Assembly
3	169840	Spindle Assembly, L.H.
4	169839	Spindle Assembly, R.H.
5	6266H	Bearing, Race, Thrust, Hardened
6	121748X	Washer 25/32 x 1-5/8 x 16 Gauge
8	12000029	Ring, Klip
10	175121	Draglink
11	STD551137	Washer, Lock
12	73940800	Nut Hex Jam Toplock 1/2-20 Unf
13	136518	Spacer Brg Axle Front
15	145212	Nut Hexflange Lock
17	177883	Shaft Assembly, Steering
29	17060612	Screw, 3/8-16 x 3/4
32	170162	Rod, Tie
33	19111216	Washer 11/32 x 3/4 x 16 Ga.
34	STD551131	Washer Lock Hvy Spr. 5/16
35	73540500	Crownlock Nut 5/16-24 Unf
36	155105	Bushing, Steering
37	152927	Screw
38	175140X418	Insert, Steering Wheel
40	STD541537	Nut Lock Center 3/8-24 Unf
41	159945	Adaptor, Steering Wheel
42	174530X418	Boot, Steering Shaft
43	121749X	Washer 25/32 x 1-1/4 x 16 Gauge
46	121232X	Cap, Spindle
65	160367	Spacer Brace Axle
67	72140618	Bolt Rdhd Sq 3/8-16 UNC x 2-1/4
68	169827	Axle, Brace
71	175146	Steering Asm
72	19182411	Washer 9/16 Id x 1-1/2Od 11 G Zin
82	169835	Bracket Susp Chassis Front
87	173966	Washer Flat .781 x 1-1/2 x .14
88	175118	Bolt Shoulder 7/16-20 Unc
91	175553	Clip Steering

NOTE: All component dimensions given in U.S. Inches
1 Inch = 25.4 mm

TRACTOR -- MODEL NUMBER 917.272262

ENGINE

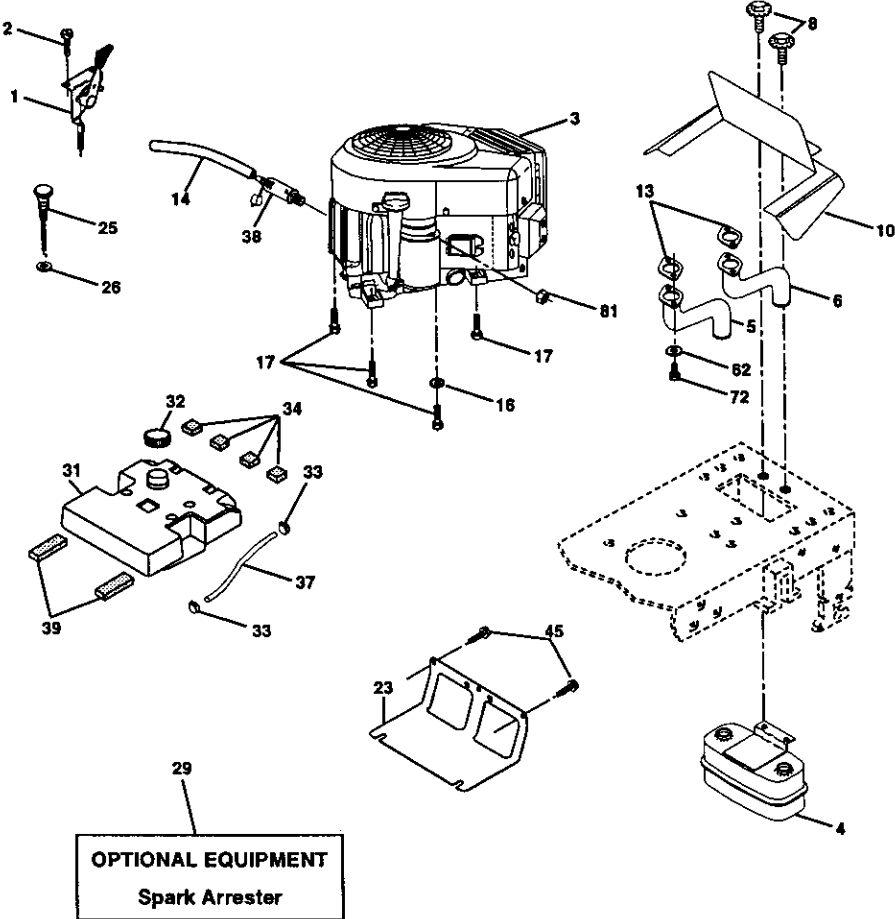

ENGINE

TRACTOR -- MODEL NUMBER 917.272262

KEY PART NO.	NO.	DESCRIPTION
1	175437X505	Control, Throttle
2	164863	Screw Hwtd H.-Lo #13016 x 3/4
3	-----	Engine, (See Breakdown) B&S Model Number 445777-0154-E1
4	149723	Muffler
5	158955	Pipe Exhaust Lh
6	160589	Pipe Exhaust Rh
8	171877	Bolt 5/16-18 Unc x 3/4
10	162797X431	Shield Heat
13	165391	Gasket (See Engine Breakdown)
14	148456	Tube Drain Oil Easy
16	11050600	Washer, Lock, External Tooth 3/8
17	17490624	Screw Thdrol 3/8-16 x 1-1/2
23	169837	Shield, Browning / Debris Guard
25	175440X505	Choke Control
26	73920600	Nut, Keps 3/8-24 Unf
29	137180	Kit, Spark Arrestor
31	157103	Tank Fuel
32	161696	Cap Asm Fuel
33	123487X	Clamp, Hose
34	106082X	Pad, Spacer
37	8543R	Line, Fuel
38	148315	Plug Drain Oil Easy
39	109227X	Pad, Idler
45	17000612	Screw Hexwsh Thdr 3/8-16 x 3/4
62	10040500	Washer Lock 5/16
72	71070512	Screw Hex Cap 5/16-18 x 3/4
81	73510400	Nut Keps Hex 1/4-20 UNC

NOTE: All component dimensions given in U.S. inches
1 Inch = 25.4 mm

TRACTOR -- MODEL NUMBER 917.272262

SEAT ASSEMBLY

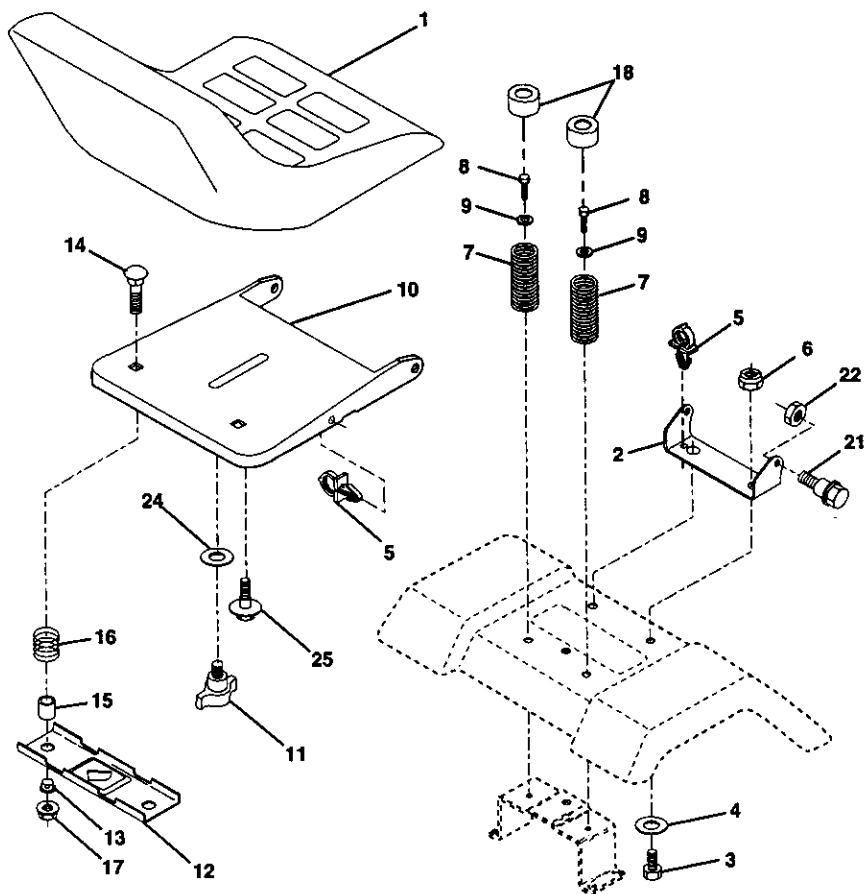

KEY PART NO.	NO.	DESCRIPTION
1	175134	Seat
2	140551	Bracket, Pivot, Seat
3	71110616	Bolt
4	19131610	Washer 13/32 x 1 x 10 Gauge
5	145006	Clip, Push-In Hinged
6	STD541437	Nut
7	124181X	Spring, Seat
8	17000616	Screw 3/8-16 x 1-1/2
9	19131614	Washer 13/32 x 1 x 14 Gauge
10	174894	Pan, Seat
11	177957	Knob Seat
12	121246X	Bracket, Switch Mounting
13	121248X	Bushing, Snap

KEY PART NO.	NO.	DESCRIPTION
14	72050412	Bolt, Carriage 1/4-20 x 1-1/2
15	121249X	Spacer, Split
16	123740X	Spring
17	123976X	Locknut, Flange 1/4 Grade 5
18	124238X	Cap Spring Seat
21	171852	Bolt, Shoulder 5/16-18 UNC
22	STD541431	Nut
24	19171912	Washer 17/32 x 1-3/16 x 12 Gauge
25	127018X	Bolt, Shoulder 5/16-18 x .62

NOTE: All component dimensions given in U.S. inches
1 inch = 25.4 mm

TRACTOR -- MODEL NUMBER 917.272262

DECALS

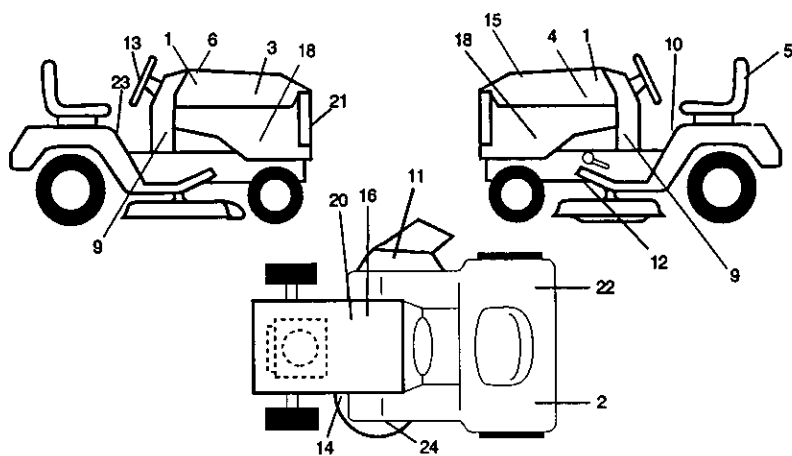

KEY PART NO.	NO.	DESCRIPTION
1	177888	Decal, Hood/Seat
2	174969	Reflector L.H.
3	177909	Decal, Hood, R.H.
4	177910	Decal, Hood, L.H.
5	178989	Decal, Seat Craftsman LTX
6	133644	Decal, Customer Maintenance
9	177975	Decal, Dash Lwr
10	156439	Decal, Fender Danger
11	178482	Decal, Desk Heavy Duty
12	146046	Decal, V-Belt Drive Schematic
13	177890	Decal Strg Wheel
14	175291	Decal, V-Belt Schematic
15	177258	Decal Repic

KEY PART NO.	NO.	DESCRIPTION
16	138047	Decal, Battery Diehard
18	177913	Decal, Panel Slide
20	149516	Decal, Battery Dngr/Psn Eng
21	177889	Decal, Grille
22	174970	Reflector RH
23	177955	Decal, Fender Oper Cruise
24	178455	Decal, Deck Caution
--	138311	Decal, Lift Handle
--	174998X418	Pad Footrest LH
--	175542X418	Pad Footrest RH
--	169210	Decal, By Pass Lt Hydro
--	179423	Owner's Manual, English
--	179424	Owner's Manual, Spanish

WHEELS & TIRES

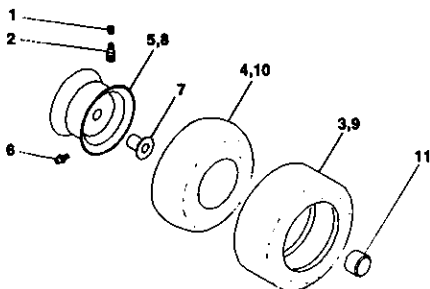

KEY PART NO.	NO.	DESCRIPTION
1	59192	Valve Cap, Tire
2	65139	Stem, Valve
3	177750	Tire, Front
4	59904	Tube, Front Tire (Not Provided, Service Item Only)
5	106732X417	Rim, Front
6	278H	Fitting, Grease (Front Wheel Only)
7	9040H	Bearing, Flange (Front Wheel Only)
8	106108X417	Rim, Rear
9	177751	Tire, Rear
10	7152J	Tube, Rear Tire (Not Provided, Service Item Only)
11	104757X417	Cap, Axle
--	144334	Sealant, Tire 10 oz.

NOTE: All component dimensions given in U.S. Inches
1 inch = 25.4 mm

TRACTOR -- MODEL NUMBER 917.272262
LIFT ASSEMBLY

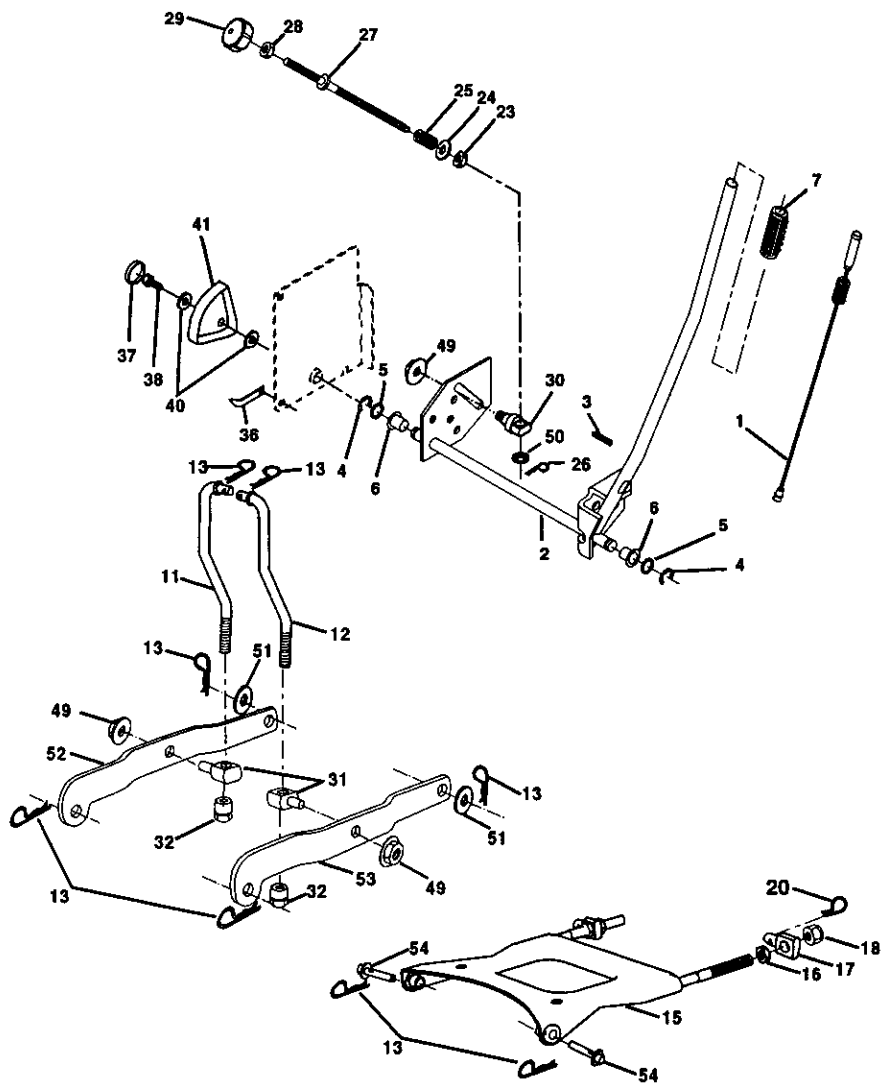

LIFT ASSEMBLY**TRACTOR -- MODEL NUMBER 917.272262**

KEY PART NO.	NO.	DESCRIPTION
1	176263	Plunger Assembly
2	159476	Shaft Assembly, Lift
3	178981	Pin, Groove
4	12000002	E-Fling
5	19211621	Washer 21/32 x 1 x 21 Gauge
6	120183X	Bearing, Nylon
7	175830	Grip, Handle, Fluted
11	175370	Link, Lift, L.H.
12	175371	Link, Lift, R.H.
13	4939M	Retainer Spring
15	175562	Plate Arm Suspension Front
16	73350800	Nut Jam Hex 1/2-13 Unc
17	175689	Trunnion Front Susp.
18	73800800	Nut Lock w/Wsh 1/2-13 Unc
20	163552	Retainer Spring
31	176205	Trunion Sups. Arm.
32	175994	Nut Lift Link 7/16-20
36	155097	Pointer Height Indicator
37	123935X	Plug Hole
38	17060516	Screw 5/16-18 x 1
40	19112410	Washer 11/32 x 1-1/2 x 10 Ga
41	155098	Indicator Height Stit
49	145212	Nut Hex/Large Lock
51	19171416	Washer 17/32 x 7/8 x 16 Ga.
52	175378	Arm Suspension Rear LH
53	175802	Arm Suspension Rear RH
54	175560	Pin Flange

NOTE: All component dimensions given in U.S. inches
1 inch = 25.4 mm

TRACTOR -- MODEL NUMBER 917.272262

MOWER DECK

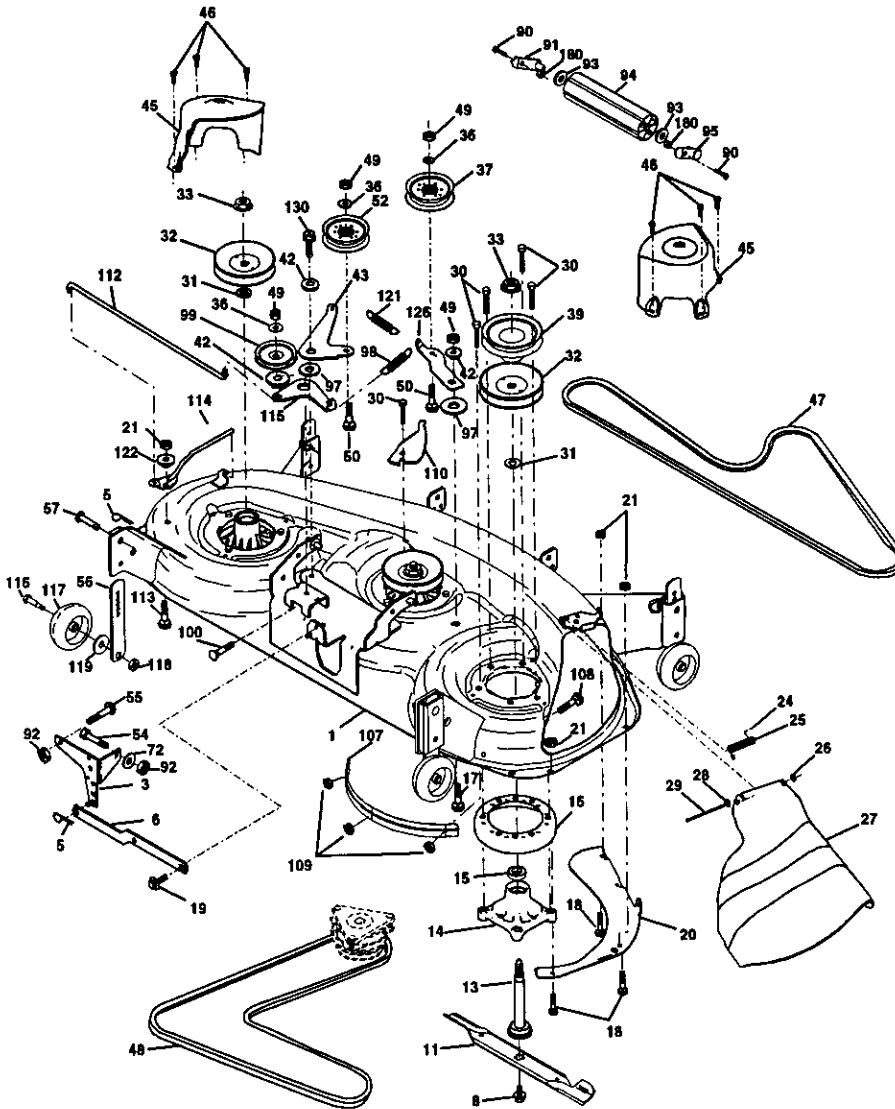

TRACTOR -- MODEL NUMBER 917.272262

MOWER DECK

KEY PART NO. NO.	DESCRIPTION	KEY PART NO. NO.	DESCRIPTION
1 174348	Deck Weldment Mower 48	54 74780616	Bolt Fin Hex 3/8-16 x 1
3 138017	Bracket Asm., Sway Bar	55 72140608	Bolt Rdhd Sqnk 3/8-16 x 1
5 4939M	Retainer Spring	56 155986	Bar Pnt Adj.
6 130832	Arm, Suspension, Rear (Sway Bar)	57 156941	Pin Head Rivet
8 174365	Bolt 7/16 Asm. Blade	72 19131312	Washer 13/32 x 13/16 x 12 Ga.
11 173920	Blade	91 175384	Bracket Asm Noseroller LH
13 174360	Shaft Mandrel Asm. Greaseable	92 73800600	Nut Lock Hex w/Ins. 3/8-16
14 174358	Housing Mandrel	94 178066	Noseroller
15 110485X	Bearing, Ball, Mandrel	95 175996	Bracket Asm Noseroller RH
16 174493	Stripper Mandrel Deck	97 133943	Washer Hardened
17 72110610	Bolt RDHD Sq Neck 3/8-16 x 1.25	98 174370	Spring Primary Drive
18 72140505	Bolt, Carriage 5/16-18 x 5/8	99 175080	Pulley Idler V*
19 132827	Bolt, Hex Hd, Shoulder 5/16-18	100 72110618	Bolt RDHD Sqnk 3/8-16 UNC x 2
20 174378	Baffle, Vortex Mower	107 175294	Baffle Vac Edge Mower
21 73680500	Nut, Crownlock 5/16-18 UNC	108 72110404	Bolt Carr.
24 105304X	Cap, Sleeve	109 73680400	Nut Crownlock 1/4-20
25 178102	Spring, Torsion	110 175016	Arm Spring Secondary
26 110452X	Nut, Push	112 174387	Link Tension Relief Lever
27 174346X428	Deflector Shield	113 72110508	Bolt Carr. 5/16-18 x 1
28 19111016	Washer 11/32 x 5/8 x 16 Ga.	114 174384	Tension Asm Relief Lever
29 131491	Rod, Hinge	115 174609	Arm Spring Tension Relief
30 173984	Screw, Thdroll Washer Head	116 137644	Bolt, Shoulder
31 129963	Washer, Spacer Mower Vented	117 174873	Gauge Wheel
32 177865	Pulley, Mandrel	118 73930600	Nut, Centerlock 3/8-16 UNC
33 178342	Nut, Fig. Top Lock Cntr. 9/16	119 19121414	Washer 3/8 x 7/8 x 14 Ga.
36 19131316	Washer 13/32 x 13/16 x 16 Ga.	121 174371	Spring Secondary Drive
37 177968	Pulley, Idler, Flat	122 174606	Bushing Pivot Tension Relief
39 174375	Pulley, Idler, Driven	126 174372	Arm, Idler, Primary Deck
42 165723	Spacer, Retainer	130 17060618	Screw 3/8-16 x 1.0
43 174373	Arm, Idler Secondary	132 17060612	Screw Thdroll 3/8-16 x 3/4
45 174343	Cover, Mandrel Deck	-- 175312	Replacement Mower, Complete
46 137729	Screw, Thdroll, 1/4-20 x 5/8	-- 174356	Mandrel Asm. Service (Includes Key Nos. 13-15)
47 174369	V-Belt, Mower, Secondary		
48 174368	V-Belt, Mower, Primary		
49 73680600	Nut, Crownlock 3/8-16 UNC		
50 72110612	Bolt, Carr. 3/8-16 x 1-1/2 Gr. 5		
52 175820	Pulley Idler Flat		

NOTE: All component dimensions given in U.S. inches
1 Inch = 25.4 mm

**TRACTOR -- MODEL NUMBER 917.272262
HYDRO GEAR TRANSAXLE -- MODEL NUMBER 323-0510**

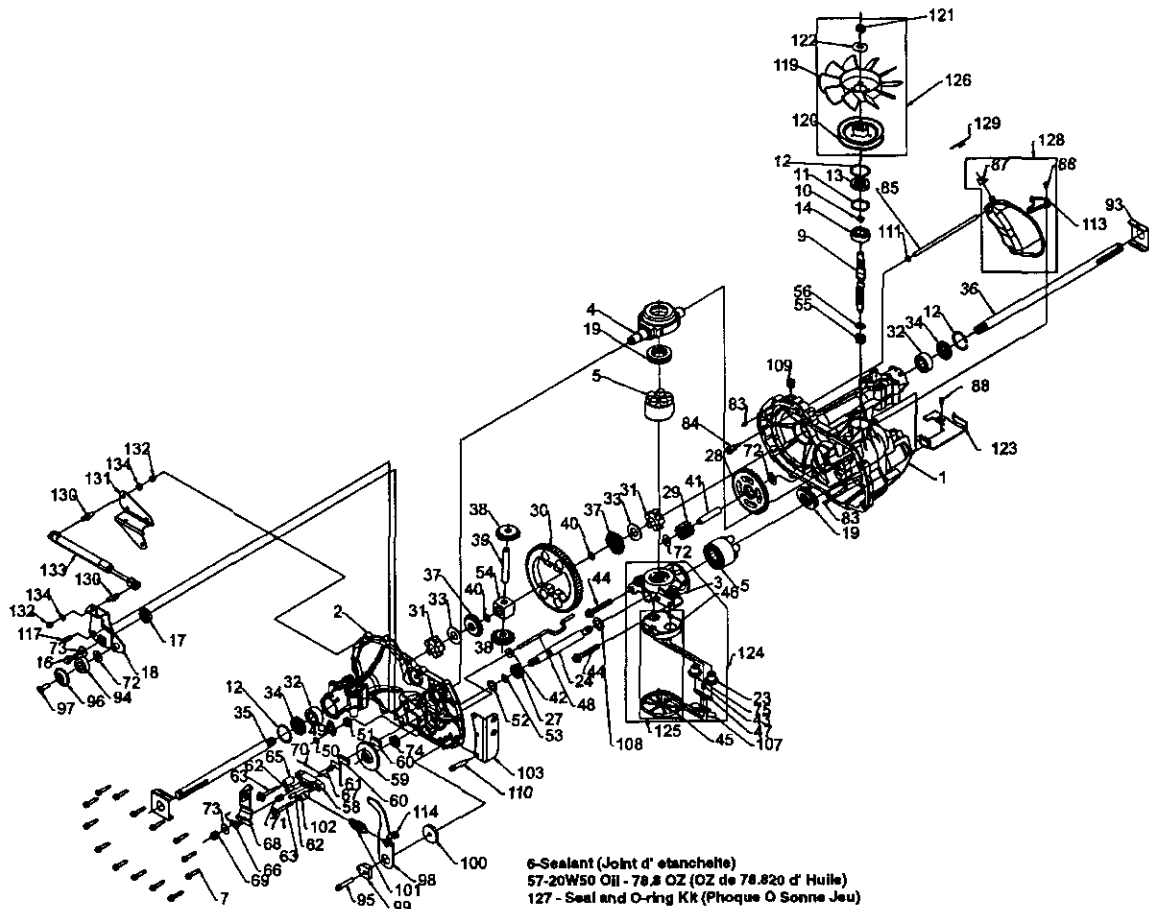

**TRACTOR -- MODEL NUMBER 917.272262
HYDRO GEAR TRANSAXLE -- MODEL NUMBER 323-0510**

KEY PART NO.	NO.	DESCRIPTION	KEY PART NO.	NO.	DESCRIPTION
1	170351	Main Housing, Assembly	67	170413	Sq. Hd. Bolt 5/16-24-Ribbed
2	170352	Side Housing, Assembly	68	178782	Arm, Brake
3	170353	Center Section, Assembly	69	170415	Slotted Hex Nut 5/16-24
4	170354	Swashplate, Trunion Machined	70	170416	Cotter Pin 3/32 X 3/4
5	169898	Block - Assembly	71	170417	Compression Spring Brake Anti- Drag
6	170355	Sealant 10.5 Oz			
7	170356	Hex Flange Screw 1/4-20 X 1.25	72	170418	Washer, Ht. .5 I.D. X 1 O.D. X .032
8	170357	Stud, 5/16-24 Hex Double End			
9	170358	Shaft, Input	73	142884	Flat - Washer 11/32 I.D. X 7/8 Od
10	170359	Ring - Retaining	74	170419	Oil Seal .625 X 1.0 X .25
11	170360	Spacer	75	170420	Check Plug Assembly, .027, Washer
12	169870	Ring - Retaining			
13	170361	Seal, Lip .67 X 1.58 X .276	76	170421	Stud, 5/16-24 Friction Pack
14	169869	Ball Brg 17mm Id X 40mm Od X 12mm	77	170422	Puck, .330 X 1.50 X .0975
			78	142969	Spring, Helical Comp
16	170362	Hex Flange Head Screw 5/16- 24X0.75	79	142980	Spacer
			80	150778	Hex Lock Nut 5/16-24Unjfl(Nylon Insert)
17	170363	Lip Seal 18 X 32 X 7			
18	178781	Arm, Control	81	170423	Wedge, Friction Pack
19	150771	Bearing, 30x52x13 Thrust	82	170424	Clip, Washer .316x1.50x.1046 (Plated)
23	170365	Check Plug Assembly, Washer			
24	170366	Shaft, Motor	83	161168	Pin, Standard Headless
27	170367	Gear - Pinion, 13t	84	170425	Fitting, 5/16 Sae 5/32 Tube
28	170368	10t/48t Gear	85	170426	Hose, Expansion Tank
29	170369	Gear, 10t Jackshaft	87	142917	Cap - Poppet Valve
30	170370	60t Bull Gear	88	170429	Bolt, Self Tapping 10-32 X 1/2
31	170371	Sleeve Bearing .75 X 1.575 X .625	90	170430	Puck, Inner Wedge
			93	170431	Spring Clip - Housing Thrust
32	170389	Sleeve Bearing(Outboard) .75x1.750x.625	94	178783	Bearing, Ball
			95	178784	Screw, Socket Head Cap 5/16- 24X1-1/2
33	142991	Washer, 3/4 Id X 1-1/2 Od X .13 Thk	96	178786	Spacer, Locating
34	170390	Lip Seal Axle Seal	97	178787	Screw, SFHCS 5/16-18 X1
35	170391	Shaft, Axle .75 X 11.39(Key,R.H.)	98	178789	Arm Return
36	170392	Shaft, Axle .75 X 16.99 (Key,L.H.)	99	178792	Puck, Adjusting
37	150792	Miter Gear (Spined)	100	178793	Washer, .24 ID X 1.60 OD X .239
38	150793	Miter Gear 15t (0.5 Id)	101	178794	Spring, Extension
39	150809	Shaft	102	178795	Spacer .260 ID X .560 OD X .870
40	170393	Ring, Spiral Retaining	103	178796	Bracket, Torque
41	170394	Pin, Jackshaft	107	170432	Deflector
42	170395	Magnet, Ring	108	170433	Washer, Motor Shaft .71 Id x 1.150 Od x .030 Thk
43	170396	Spring, Bypass			
44	150797	Hydro Mtg Screw 3/8-24 X 2.5 Lg	109	170434	Plug, Sae #6
45	170397	Filter	111	170435	O-Ring .07 X .301 I.D.
48	170398	Base, Filter	113	170437	Bracket, Support Expansion Tank
47	170399	Actuator, Bypass	114	178797	Spring
48	170400	Rod, Bypass Actuator	116	170438	Silicon Sponge
49	170401	Arm, Bypass	117	178799	Pin, Spring
50	170402	Retaining Ring .250 External	119	170439	Fan, 7 In.
51	170403	Seal, Lip .741 X .250 X .250 Tc	120	170440	Pulley
52	170404	Flat Washer, 5/8 Id x 1.0 Od x .05 Thk	121	170441	Hex Lock Nut 1/2-20 (Nylon Ins.)
			122	170442	Washer, Belleville
53	170405	Retaining Ring	123	178800	Belt Keeper
54	170406	Bearing, Center Block	124	170444	Center Section-Filter-Bypass Asm.
55	142977	Spring - Helical Compression	125	170445	Filter Assembly
56	142978	Washer	126	170446	Fan - Pulley Service Assembly
57	150798	20w-50 Oil	127	170447	Seal - O-Ring Kit
58	170407	Brake Yoke	128	173165	Kit, Expansion Tank
59	170408	Rotor, Brake	130	178802	Stud Ball
60	142883	Brake Puck	131	178803	Bracket, Cruise Damper
61	142882	Puck Plate	132	178804	Hex Nut 5/16-18 NC
62	142887	Brake Actuating Pin	133	178806	Damper
63	170410	Hfths 1/4-20x2 W/ Patch, Special Flange	134	178808	Washer, Helical Spring Lock 5/16
			900	173839	Transaxle Complete
64	142892	Bolt, 1/4-20 X 1 W/Patch			
65	170411	Spacer			
66	170412	Spring, Brake Arm Bias			

NOTE: All component dimensions given in U.S. inches
1 Inch = 25.4 mm

TRACTOR -- MODEL NUMBER 917.272262
BRIGGS & STRATTON ENGINE-MODEL NUMBER 445777 TYPE NUMBER 0154-E1

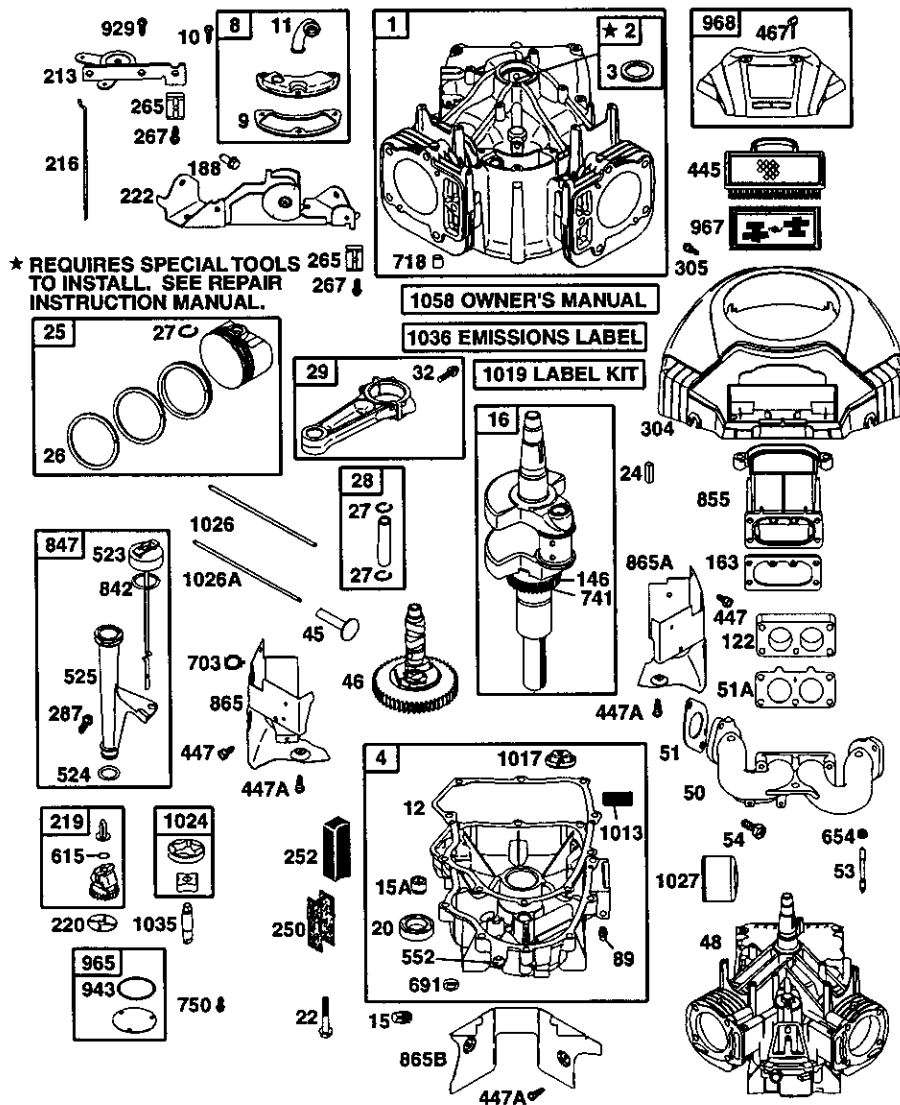

TRACTOR -- MODEL NUMBER 917.272262
BRIGGS & STRATTON ENGINE-MODEL NUMBER 445777 TYPE NUMBER 0154-E1

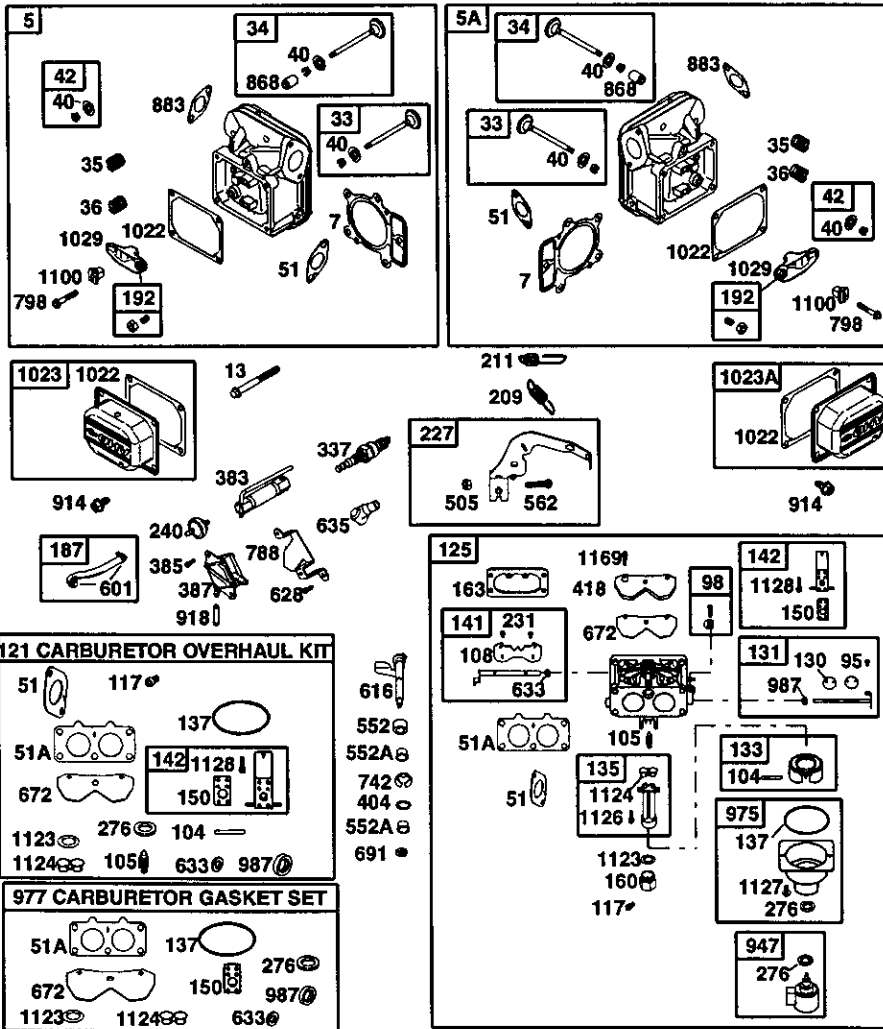

TRACTOR -- MODEL NUMBER 917.272262
BRIGGS & STRATTON ENGINE-MODEL NUMBER 445777 TYPE NUMBER 0154-E1

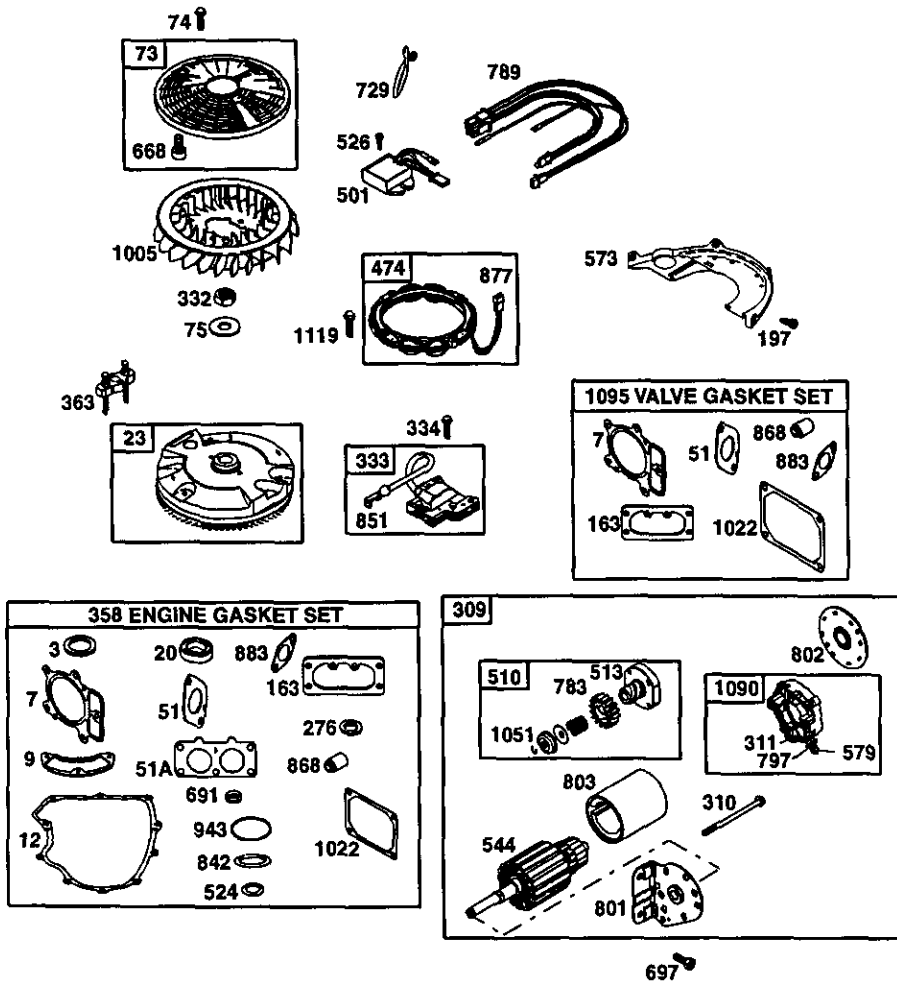

TRACTOR -- MODEL NUMBER 917.272262
BRIGGS & STRATTON ENGINE-MODEL NUMBER 445777 TYPE NUMBER 0154-E1

KEY NO.	PART NO.	DESCRIPTION	KEY NO.	PART NO.	DESCRIPTION
1	694001	Cylinder Assembly	130	690993	Valve-Throttle
2	499585	Bushing/Seal Kit	131	499805	Kit-Throttle Shaft
3	391086	• Seal-Oil (Magneto Side)	133	499806	Float-Carburetor
4	690069	Sump-Engine	135	499803	Tube-Fuel Transfer
5	693998	Head-Cylinder (Cylinder 1)	137	690994 Ø‡	Gasket-Float Bowl
5A	693999	Head-Cylinder (Cylinder 2)	141	499807	Kit-Choke Shaft
7	693997	+ Gasket-Cylinder Head	142	499808 Ø	Nozzle-Carburetor
8	499601	Breather Assembly	146	690979	Key-Timing
9	690937	• Gasket-Breather	150	690995 Ø‡	Gasket-Nozzle
10	690960	Screw (Breather Assembly)	160	690996	Retainer-Solenoid
11	690942	Tube-Breather	163	691001	+ Gasket-Air Cleaner
12	690945	• Gasket-Crankcase	187	693180	Line-Fuel
13	690360	Screw (Cylinder Head)	188	690960	Screw (Control Bracket)
15	690946	Plug-Oil Drain	192	690083	Adjuster-Rocker Arm
15A	691680	Plug-Oil Drain	197	690960	Screw (Back Plate)
16	691046	Crankshaft	209	691018	Spring-Governor
20	690947	• Seal-Oil (PTO Side)	211	691019	Spring-Governed Idle
22	694966	Screw (Crankcase Cover)	213	691021	Bracket-Choke Control
23	691053	Flywheel	216	691022	Link-Choke
24	222698	Key-Flywheel	219	696376	Gear-Governor
25	694003	Piston Assembly (Standard)	220	690412	Washer (Governor Gear)
	694005	Piston Assembly (.010 Oversized)	222	691023	Bracket-Control
	694007	Piston Assembly (.020 Oversized)	227	691048	Lever-Governor Control
	694009	Piston Assembly (.030 Oversized)	231	690718	Screw (Choke Valve)
26	694004	Ring Set (Standard)	240	691035	Filter-Fuel
	694006	Ring Set (.010 Oversized)	250	690957	Retainer-Breather
	694008	Ring Set (.020 Oversized)	252	690956	Collector-Oil
	694010	Ring Set (.030 Oversized)	265	691024	Clamp-Casing
27	690975	Lock-Piston Pin	267	695134	Screw (Casing Clamp)
28	690229	Pin-Piston (Standard)	276	690997*Ø‡	Washer-Sealing
29	499583	Rod-Connecting (Standard)	287	690960	Screw (Dipstick/Tube Assembly)
32	690976	Screw (Connecting Rod)	304	695277	Housing-Blower
33	499596	Valve-Exhaust	305	691005	Screw (Blower Housing)
34	499597	Valve-Intake	309	691262	Motor-Starter
35	690963	Spring-Valve (Intake)	310	691263	Screw (Starter Motor)
36	690963	Spring-Valve (Exhaust)	311	497608	Brush Set
40	690964	Retainer-Valve	332	691059	Nut (Flywheel)
42	499596	Keeper-Valve	333	691060	Armature-Magneto
45	690977	Tappet-Valve	334	691061	Screw (Magneto Armature)
46	690978	Camshaft	337	691043	Sparkplug
48	693893	Short Block (Replacement Engine 445777-0027-E2)	358	694012	Gasket Set-Engine
50	690948	Manifold-Intake	363	691062	Puller-Flywheel
51	690949*Ø+	Gasket-Intake	383	690966	Wrench-Sparkplug
51A	690950*Ø‡	Gasket-Intake	385	690960	Screw (Fuel Pump)
53	690951	Stud-Carburetor	387	808656	Pump-Fuel
54	690953	Screw (Intake Manifold)	404	690442	Washer (Governor Crank)
73	691055	Screen-Rotating	418	690999	Plate-Carburetor
74	691057	Screw (Rotating Screen)	445	499486	Filter-Air Cleaner Cartridge
75	691056	Washer (Flywheel)	447	691003	Screw (Air Guide Cover)
89	690283	Plug-Oil	447A	690960	Screw (Air Guide Cover)
95	690718	Screw (Throttle Valve)			• Included in Engine Gasket Set, Key. No. 358
98	499802	Kit-Idle Speed			Ø Included in Carburetor Overhaul Kit, Key. No. 121
104	690984	Ø Pin-Float Hinge			‡ Included in Carburetor Gasket Set, Key. No. 977
105	690985	Ø Valve-Float Needle			+ Included in Valve Overhaul Kit, Key. No. 1095
108	690986	Valve-Choke			
117	690232	Ø Jet-Main (Standard)			
	690989	Jet-Main (High Altitude)			
121	499811	Kit-Carburetor Overhaul			
122	690952	Spacer-Carburetor			
125	499804	Carburetor			

NOTE: All component dimensions given in U.S. inches 1 inch = 25.4 mm

**TRACTOR -- MODEL NUMBER 917.272262
BRIGGS & STRATTON ENGINE-MODEL NUMBER 445777 TYPE NUMBER 0154-E1**

KEY NO.	PART NO.	DESCRIPTION	KEY NO.	PART NO.	DESCRIPTION
467	691008	Knob-Air Cleaner	868	690968	*+ Seal-Valve
474	691064	Alternator	877	399916	Wire/Connector-Alternator
501	691185	Regulator	883	690970	*+ Gasket-Exhaust
505	691029	Nut (Governor Control Lever)	914	690960	Screw (Rocker Arm Cover)
510	497606	Drive-Starter	918	694000	Hose-Vacuum
513	692024	Clutch-Drive	929	691003	Screw (Choke Control Bracket)
523	691036	Dipstick	943	690589	* Seal-O Ring (Oil Pump Cover)
524	691032	• Seal-O Ring (Dipstick Tube)	947	499809	Solenoid-Fuel
525	691037	Tube-Dipstick	965	499613	Cover-Oil Pump
526	690960	Screw (Regulator)544	967	273638	Filter-Pre Cleaner
		Armature-Starter (Serviced by 691262 Starter Motor Only)	968	499788	Cover-Air Cleaner
552	690552	Bushing-Governor Crank	975	499810	Bowl-Float
552A	690553	Bushing-Governor Crank	977	499812	Gasket Set-Carburetor
562	690311	Bolt (Governor Control Lever)	987	691000	Ø‡ Seal-Throttle Shaft
573	691009	Plate-Back	1005	691243	Fan-Flywheel
579	691029	Nut (Starter Cable)	1013	690954	Nipple-Oil Filter
601	95162	Clamp-Hose	1017	690770	Screen-Oil Pump
615	690317	Retainer-Governor Shaft	1019	693995	Kit-Label
616	691045	Crank-Governor	1022	690971	*+ Gasket-Rocker Cover
628	690960	Screw (Fuel Pump Bracket)	1023	499599	Cover-Rocker Arm (Cylinder 1)
633	690998	Ø‡ Seal-Choke/Throttle Shaft	1023A	499600	Cover-Rocker Arm (Cylinder 2)
635	66538	Boot-Sparkplug	1024	499054	Pump-Oil
654	690958	Nut (Carburetor)	1026	690981	Rod-Push (Steel)
668	691215	Spacer	1026A	690982	Rod-Push (Aluminum)
672	690234	Ø‡ Gasket-Carburetor Plate	1027	492932	Filter-Oil
691	690657	• Seal-Governor Shaft	1029	690972	Arm-Rocker
697	690372	Screw (Drive Cap)	1035	691042	Shaft-Pump
703	691010	Clip	1036	695704	Label-Emission
718	690959	Pin-Locating	1051	691265	Ring-Retaining
729	694123	Clip-Wire	1058	274794	Owner's Manual
741	690980	Gear-Timing	1090	691293	Retainer-Brush
742	690328	Retainer-E Ring	1095	694013	Set-Valve Gasket
750	691033	Screw (Oil Pump Cover)	1100	690973	Pivot-Rocker Arm
783	693058	Gear-Pinion	1119	691183	Screw (Alternator)
788	691039	Bracket-Fuel Pump	1123	690987	Ø‡ Seal-O Ring (Solenoid Retainer)
789	695050	Wiring-Harness	1124	690988	Ø‡ Seal-O Ring (Fuel Transfer Tube)
797	693167	Nut (Brush Retainer)	1126	690991	Screw (Fuel Transfer Tube)
798	690967	Screw (Rocker Arm)	1127	690992	Screw (Float Bowl)
801	691283	Cap-Drive	1128	690990	Ø Screw (Carburetor Nozzle)
802	691286	Cap-End	1169	693140	Screw (Carburetor Cover Plate)
803		Housing-Starter (Serviced by 691262 Starter Motor Only)			
842	691031	• Seal-O Ring (Dipstick)			
847	499602	Assembly-Dipstick/Tube			
851	493880	Terminal-Sparkplug			
855	691011	Adapter-Air Cleaner			
865	691012	Cover-Air Guide (Cylinder 1)			
865A	691014	Cover-Air Guide (Cylinder 2)			
865B	691015	Cover-Air Guide			
			•		Included in Engine Gasket Set, Key. No. 358
			Ø		Included in Carburetor Overhaul Kit, Key. No. 121
			‡		Included in Carburetor Gasket Set, Key. No. 977
			+		Included in Valve Overhaul Kit, Key. No. 1095

NOTE: All component dimensions given in U.S. inches 1 inch = 25.4 mm

SERVICE NOTES

SERVICE NOTES

SUGGESTED GUIDE FOR SIGHTING SLOPES FOR SAFE OPERATION

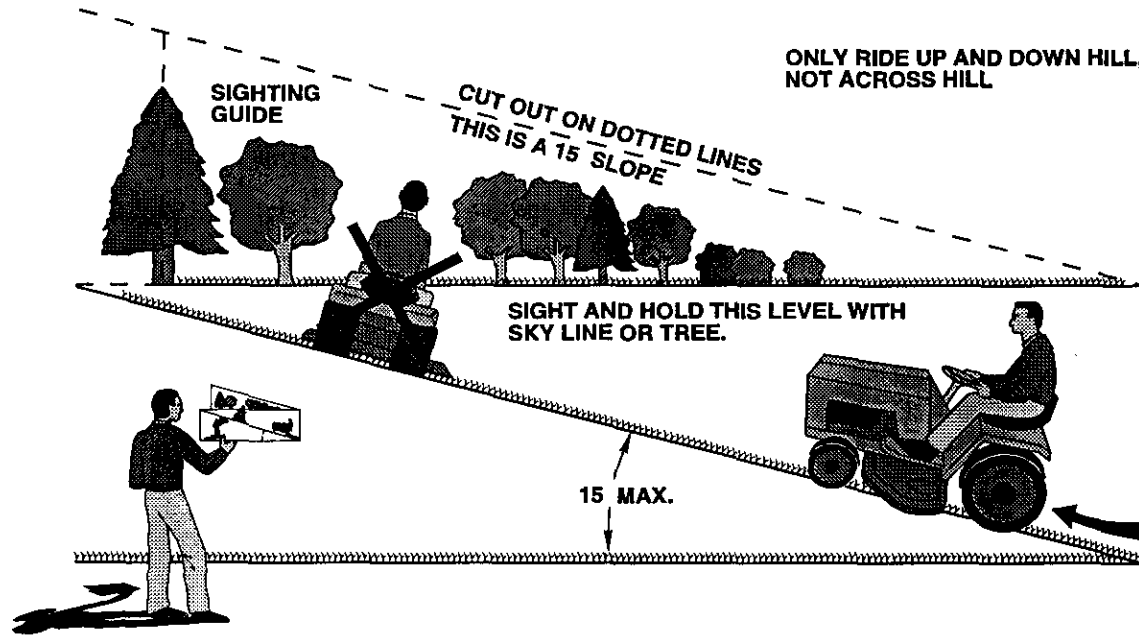

Operate your Tractor up and down the face of slopes (not greater than 15), never across the face. Make turns gradually to prevent tipping or loss of control. Exercise extreme caution when changing direction on slopes.

Get it fixed, at your home or ours!

For repair of major brand appliances in your own home . . .
no matter who made it, no matter who sold it!

1-800-4-MY-HOME[®] Anytime, day or night
(1-800-469-4663) (U.S.A. and Canada)
www.sears.com www.sears.ca

For repair of carry-in products like vacuums, lawn equipment, and
electronics, call for the nearest **Sears Parts and Repair Center**.

1-800-488-1222 Anytime, day or night (U.S.A. only)
www.sears.com

For the replacement parts, accessories and owner's manuals
that you need to do-it-yourself, call **Sears PartsDirectSM**!

1-800-366-PART 6 a.m. – 11 p.m., 7 days a week
(1-800-366-7278) (U.S.A. only)
www.sears.com/partsdirect

To purchase or inquire about a Sears Service Agreement
or Sears Maintenance Agreement:

1-800-827-6655 (U.S.A.) **1-800-361-6665** (Canada)
7 a.m. – 5 p.m., CST, Mon. – Sat. 9 a.m. – 8 p.m. EST, M – F, 4 p.m. Sat.

Para pedir servicio de reparación a
domicilio, y para ordenar piezas:

1-888-SU-HOGARSM
(1-888-784-6427)

Au Canada pour service en français:

1-800-LE-FOYER^{MC}
(1-800-533-6937)
www.sears.ca



© Sears, Roebuck and Co.

® Registered Trademark / TM Trademark / SM Service Mark of Sears, Roebuck and Co.

® Marca Registrada / TM Marca de Fábrica / SM Marca de Servicio de Sears, Roebuck and Co.

^{MC} Marque de commerce / ^{MD} Marque déposée de Sears, Roebuck and Co.